

Supersedes all previous issues

(H)8x8x17F - 8100 SERIES

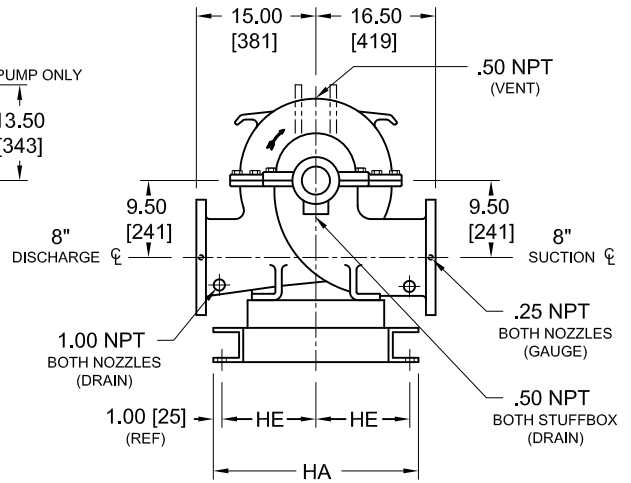
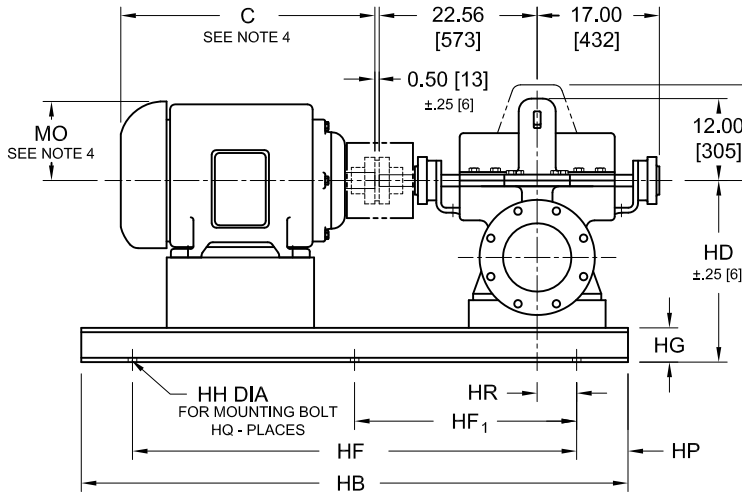

MOTOR FRAME	C	MO	HA	HB	HE	HF	HF ₁	HG	HH	HP	HR	HQ	HD
324	28.20 [717]	8.60 [219]	24.00 [610]	66.00 [1677]	11.00 [280]	54.00 [1372]	27.00 [686]	4.00 [102]	1.00 [25]	6.00 [152]	7.00 [178]	6	21.75 [553]
326	29.70 [755]	9.20 [234]											
364	30.00 [762]	9.20 [234]											
365	31.00 [788]	10.40 [265]	29.40 [747]	76.00 [1931]	13.75 [350]	66.00 [1676]	16.50 [419]	6.00 [152]	0.88 [22]	5.00 [127]	8.00 [203]	10	23.75 [604]
404	36.40 [925]	11.80 [300]											
405	37.90 [963]	11.80 [300]											
444	42.20 [1072]												
445	44.20 [1123]												
447	47.60 [1210]			86.00 [2185]		76.00 [1930]	19.00 [483]						
449	52.60 [1337]	12.10 [308]											

CW ROTATION VIEWED FROM COUPLING END

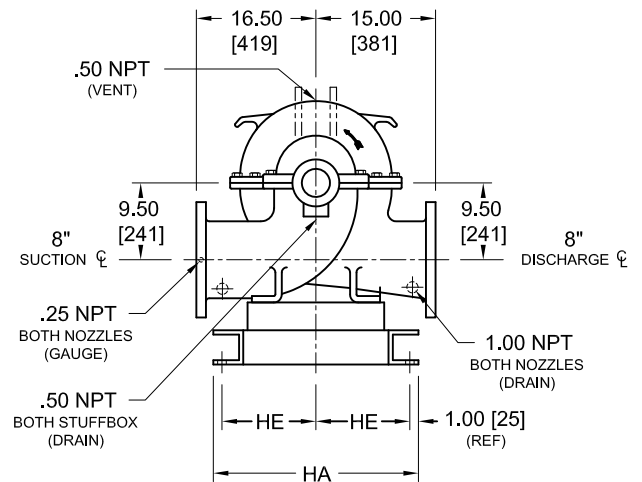

CCW ROTATION VIEWED FROM COUPLING END

NOTES :

- ALL DIMENSIONS ARE INCHES [mm].
- SUCTION AND DISCHARGE CONNECTIONS ARE DRILLED PER 125# ANSI B16.1. PUMPS WITH "H" PREFIX HAVE DISCHARGE CONNECTION DRILLED PER 250# ANSI B16.1. FLANGE HOLES STRADDLE CENTERLINE.
- BASE PLATE SETTING (BEFORE PIPING), GROUTING PROCEDURES, AND FINAL ALIGNMENT MUST BE IN ACCORDANCE WITH A-C FIRE PUMPS SYSTEMS RECOMMENDED PROCEDURES OUTLINED IN THE INSTRUCTION MANUAL ASSOCIATED WITH THIS PUMP TYPE.
- MOTOR DIMENSIONS ARE APPROXIMATE FOR A GIVEN NEMA FRAME. CONSULT FACTORY IF SPACE IS LIMITED.
- BOTH SUCTION AND DISCHARGE PIPES MUST BE SUPPORTED INDEPENDENTLY NEAR THE PUMP TO REDUCE STRAIN ON THE PUMP CASING. ALSO EXPANSION JOINTS, IF USED, MUST NOT EXERT FORCE ON CASING.
- COUPLING GUARD MEETS ANSI/OSHA REQUIREMENTS.
- CONSULT FACTORY FOR BASE MOUNTED CONTROLLER.

NOT FOR CONSTRUCTION, INSTALLATION OR APPLICATION PURPOSES UNLESS CERTIFIED									
CERTIFIED FOR:							APPROVAL		
							UL	FM	ULC
							<input type="checkbox"/>	<input type="checkbox"/>	<input type="checkbox"/>
CUSTOMER ORDER NO.:				TAG NO.			FLANGES		
PUMP DATA	SIZE	MODEL	CURVE NO.	GPM	HEAD	ROTATION	SUCTION	DISCH.	
MOTOR DATA	HP	RPM	VOLTS	PHASE	HERTZ	FRAME SIZE	ENCLOSURE		
SHOP ORDER:			CERTIFIED BY:			DATE:			