

A-C Fire Pump Systems

General Information and Engineering Data

Vertical Turbine Fire Pump - FP 2.4

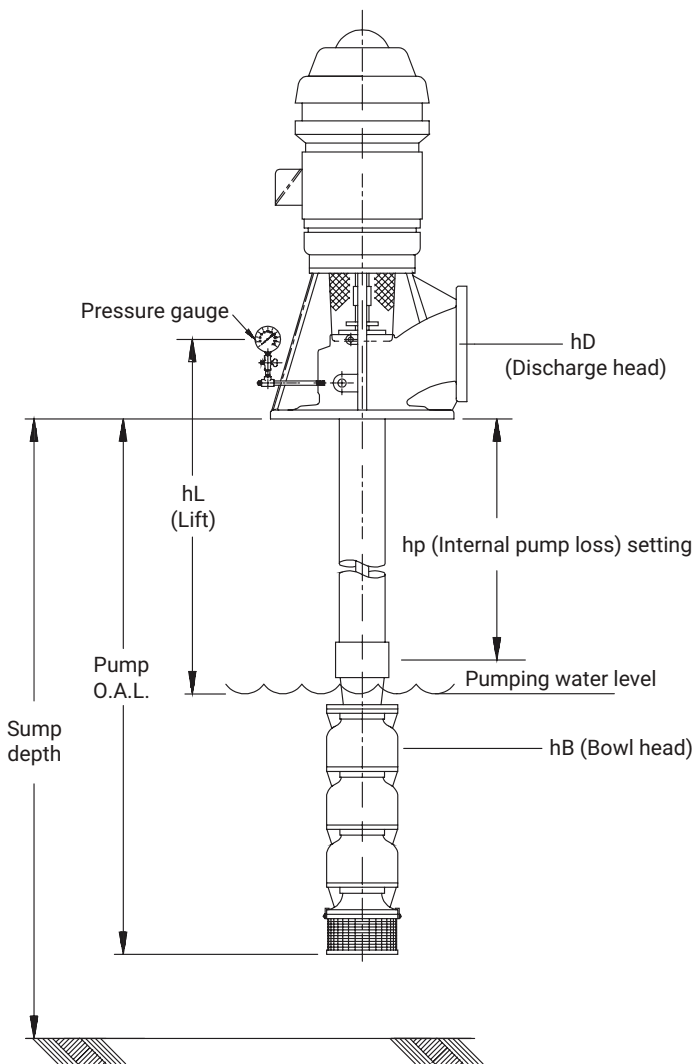

Calculation of bowl head or discharge head

For vertical turbine pumps, discharge head equals bowl head minus lift and internal pump loss.

It can be shown as:

$$h_D = h_B - h_L - h_p$$

Where h_D = Discharge head. Pressure gauge reading in PSI multiplied by 2.31 for fresh cool water.

h_B = Bowl head. Actual head in feet developed by the bowl assembly.

h_L = Lift. Elevation difference in feet between the pumping water level and the pressure gauge.

h_p = Internal pump loss. Pump column loss plus discharge head loss in feet.

Conversely, bowl head equals discharge head plus lift and internal pump loss.

$$h_B = h_D + h_L + h_p$$

NOTES:

Test curves are plotted as bowl head (h_B). Allowances must be made for lift and internal pump loss when comparing test curves to field performances.

General Information and Engineering Data

Vertical Turbine Fire Pump

Pump size	10WALC	10WALC	11CLC	11CLC	11CHC
PSI	49-139	140-206	54-130	131-256	71-150
Approval flow rate	250	250	500	500	750

Discharge head design data

Discharge flange rating	125	250	125	250	125
Head material	Ductile iron	Ductile iron	Ductile iron	Ductile iron	Ductile iron
Maximum working pressure (psig)	175 psi	400 psi	175 psi	400 psi	175 psi
Minimum submergence above bell	17.3	17.3	23.0	23.0	29.0

Stuffing box data

Shaft O.D.	Minimum	1.00	1.00	1.00	1.00	1.00
	Maximum	1.00	1.00	1.00	1.19	1.19
Packing: No. rings / size square		5/.38	5/.38	5/.38	5/.38	5/.38

Impeller design data

No. of vanes	5	5	5	5	8
Inlet area	8.60	8.60	15.60	15.60	15.60
Maximum diameter	7.31	7.31	6.63	6.63	7.13
Minimum diameter	6.50	6.50	8.13	8.13	8.13
Maximum sphere	0.45	0.45	0.68	0.68	0.68
WR ² for maximum diameter (lbs-ft ²) per stage	0.58	0.58	0.89	0.89	0.89
Wear ring clearance-diametral	.015 in. ±.001	.015 in. ±.001	.016 in. ±.002	.016 in. ±.002	.016 in. ±.002
No. of stages minimum/maximum	3/7	7/9	3/5	5/9	3/5

Shaft and bearing data

Shaft diameter (bowl)	1.50	1.50	1.69	1.69	1.69
Maximum shaft span (bearing to bearing)	120	120	120	120	120

All dimensions are in inches

General Information and Engineering Data

Vertical Turbine Fire Pump

Pump size	11CHC	12CHC	12CHC	14RJHC	14RJHC
PSI	151-323	85-140	141-352	50-145	146-295
Approval flow rate	750	1000	1000	1500	1500

Discharge head design data

Discharge flange rating	250	125	250	125	250
Head material	Ductile iron	Ductile iron	Ductile iron	Ductile iron	Ductile iron
Maximum working pressure (psig)	400 psi	175 psi	400 psi	175 psi	400 psi
Minimum submergence above bell	29.0	34.0	34.0	42.0	42.0

Stuffing box data

Shaft O.D.	Minimum	1.19	1.19	1.19	1.19	1.50
	Maximum	1.50	1.19	1.50	1.50	1.93
Packing: No. rings / size square		5/.38	5/.38	5/.38	5/.38	5/.38

Impeller design data

No. of vanes	8	8	8	8	8
Inlet area	15.60	20.43	20.43	30.24	30.24
Maximum diameter	7.13	7.75	7.75	7.75	7.75
Minimum diameter	8.13	8.69	8.69	9.82	9.82
Maximum sphere	0.68	0.73	0.73	0.98	0.98
WR ² for maximum diameter (lbs-ft ²) per stage	0.89	1.65	1.65	3.12	3.12
Wear ring clearance-diametral	.016 in. ± .002	.016 in. ± .002	.016 in. ± .002	.016 in. ± .002	.016 in. ± .002
No. of stages minimum/maximum	5/10	3/5	5/10	2/4	4/7

Shaft and bearing data

Shaft diameter (bowl)	1.69	1.69	1.69	1.94	1.94
Maximum shaft span (bearing to bearing)	120	120	120	120	120

All dimensions are in inches

General Information and Engineering Data

Vertical Turbine Fire Pump

Pump size	14RHHC	14RHHC	16DMC	16DMC	18DMC
PSI	55-135	136-257	77-145	146-186	101-147
Approval flow rate	2000	2000	2500	2500	3000

Discharge head design data

Discharge flange rating	125	250	125	250	125
Head material	Ductile iron	Ductile iron	Ductile iron	Ductile iron	Ductile iron
Maximum working pressure (psig)	175 psi	400 psi	175 psi	400 psi	175 psi
Minimum submergence above bell	50.0	50.0	50.0	50.0	87.0

Stuffing box data

Shaft O.D.	Minimum	1.18	1.50	1.50	1.68	1.68
	Maximum	1.50	1.93	1.68	1.68	1.93
Packing: No. rings / size square		5/.38	5/.38	5/.38	5/.38	5/.38

Impeller design data

No. of vanes	7	7	7	7	7
Inlet area	36.06	36.06	40.37	40.37	49.00
Maximum diameter	8.00	8.00	9.31	9.31	10.63
Minimum diameter	9.88	9.88	11.63	11.63	12.75
Maximum sphere	1.18	1.18	0.72	0.72	0.75
WR ² for maximum diameter (lbs-ft ²) per stage	5.05	5.05	9.65	9.65	13.3
Wear ring clearance-diametral	.016 in. ± .002	.016 in. ± .002	.020 in. ± .002	.020 in. ± .002	.020 in. ± .002
No. of stages minimum/maximum	2/4	4/6	2/3	3/3	2/2

Shaft and bearing data

Shaft diameter (bowl)	2.19	2.19	2.44	2.44	2.69
Maximum shaft span (bearing to bearing)	120	120	120	120	120

All dimensions are in inches

General Information and Engineering Data

Vertical Turbine Fire Pump

Pump size	18DMC	18DHC	20EHC	20EHC
PSI	94-141	105-141	56-129	55-126
Approval flow rate	3500	4000	4500	5000

Discharge head design data

Discharge flange rating	125	125	150	150
Head material	Ductile iron	Ductile iron	Ductile iron	Ductile iron
Maximum working pressure (psig)	175 psi	175 psi	285 psi	285 psi
Minimum submergence above bell	87.0	221.0	71.0	71.0

Stuffing box data

Shaft O.D.	Minimum	1.68	1.68	1.68	1.68
	Maximum	1.93	1.93	1.93	1.93
Packing: No. rings / size square		5/.38	5/.38	5/.38	5/.38

Impeller design data

No. of vanes	7	7	6	6
Inlet area	49.00	49.00	80.70	80.70
Maximum diameter	10.63	10.63	11.62	11.62
Minimum diameter	12.75	12.69	13.31	13.31
Maximum sphere	0.75	0.75	1.75	1.75
WR ² for maximum diameter (lbs-ft ²) per stage	13.3	13.3	17.16	17.16
Wear ring clearance-diametral	.020 in. ± .002	.020 in. ± .002	.021 in. ± .003	.021 in. ± .003
No. of stages minimum/maximum	2/2	2/2	1/2	1/2

Shaft and bearing data

Shaft diameter (bowl)	2.69	2.69	2.44	2.44
Maximum shaft span (bearing to bearing)	120	120	120	120

All dimensions are in inches

General Information and Engineering Data

Lineshaft Turbine - Water Lube - Cast Head - Threaded Column - Motor/Gear Driver VHS

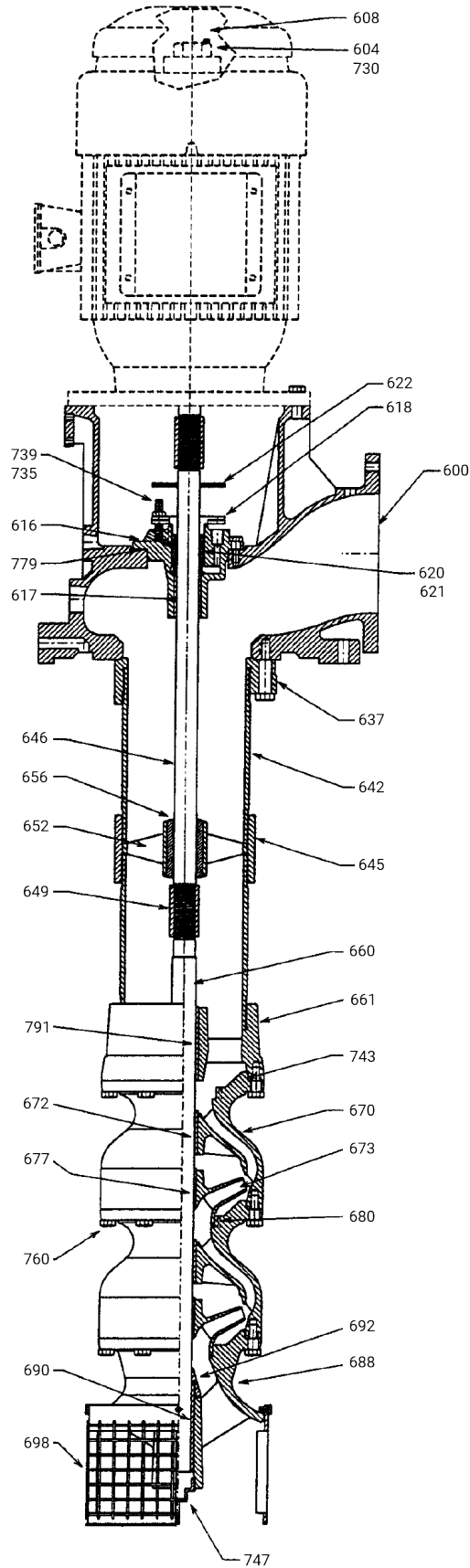

Discharge head assembly

Item	Description	Material code	Material description
608	Headshaft	2227	SST 416
604	Adjusting nut	2130	Brass
730	Gib key	2242	Steel
622	Slinger	5121	Rubber sbr
618	Stuffing box split gland	1193	Aluminum bronze
600	Discharge head	1003	Ductile iron
616	Stuffing box	1003	Cast iron
617	Stuffing box bearing	1109	Bronze
735	Stuffing box stud nut	2229	SST 316
739	Stuffing box stud	2229	SST 316
779	Stuffing box gasket	5136	Rubber sbr
620	Packing	5026	Carbon non-asbestos
621	Lantern ring	6359	Teflon (PTFE)
637	Hanger flange	1003	Cast iron

Column & lineshaft assembly

Item	Description	Material code	Material description
642	Column pipe	6501	Black Pipe
645	Column coupling	6501	Black Pipe
646	Lineshaft	2227	SST 416
656	Lineshaft bearing	5121	Rubber Sbr
649	Lineshaft coupling	2265	SST 416
652	Bearing retainer	1102	Bronze

Bowl assembly

Item	Description	Material code	Material description
660	Bowl shaft	2227	SST 416
661	Discharge bowl	1003	Cast iron
791	Discharge bearing	1109	Bronze
670	Intermediate bowl	6911	Coated cast iron
672	Inter bowl bearing	1109	Bronze
673	Impeller	1102	Bronze
677	Impeller taper lock	2242	Steel
680	Wear rings	1117	Aluminum bronze
760	Hex bolt	2298	Grade 8
692	Sand collar	1109	Bronze
688	Suction bell	1003	Cast iron
690	Suction bearing	1109	Bronze
698	Suction strainer	1102	Bronze
743	O-ring	5302	Rubber nbr
747	Plug	1046	Mal iron

Notes

Xylem
8200 N. Austin Avenue
Morton Grove, Illinois 60053

Tel +1 847.966.3700
Fax +1 847.965.8379
www.xylem.com/acfirepump

All information presented herein is believed reliable and in accordance with accepted engineering practices. Xylem makes no warranties as to the completeness of this information. Users are responsible for evaluating individual product suitability for specific applications. Xylem assumes no liability whatsoever for any special, indirect or consequential damages arising from the sale, resale or misuse of its products. Subject to change without notice.

© 2025 Xylem Inc. or its affiliates. All rights reserved. Xylem and A-C Fire Pump are trademarks or registered trademarks of Xylem Inc. or one of its subsidiaries. All other trademarks or registered trademarks are the property of their respective owners.

ACF-VTFP2.4-ED 0923 R2 March 2025

