

- Rated for 200°F (93°C) Condensate
- Carbon Graphite Bearings for improved abrasion and wear resistance
- Simplex or Duplex configuration
- Designed for installations with low or below grade return lines
- 36" or 48" Deep Receivers
- Carbon/Ceramic Mechanical Seal designed for 250°F (121°C)
- Replace Mechanical Seal without removing pump from receiver
- Heavy Duty 2-pole float switch



Domestic® Pump Series CU™ Underground Condensate Units Series CMU™ Boiler Feed Units



SELECTION DATA

ALL PUMPS ARE 3500 RPM

SQ. FT. E.D.R. = LB/hr
4

Capacity Sq. Ft. EDR	Pump Capacity (gpm)	Discharge Pressure (psig)	Std. Pump Motor H.P.	Discharge Size (inches)	CONDENSATE UNITS			BOILER FEED UNITS	
					Model No. With Std. Pumps	Receiver Size Simplex	Receiver Size Duplex	Model No. with Std. Pumps	Receiver Size
1,000 to 10,000	10	15	1/2	1 1/2	101.5CU	18" dia. x 36" deep	24" dia. x 36" deep	101.5CMU	30" dia. x 48" deep
		20	1/2		102CU			102CMU	
		25	1/2		102.5CU			102.5CMU	
		30	3/4		103CU			103CMU	
		40	1		104CU			104CMU	
50	1 1/2	105CU	105CMU						
15,000	15	15	1/2	1 1/2	151.5CU	18" dia. x 36" deep	24" dia. x 36" deep	151.5CMU	30" dia. x 48" deep
		20	1/2		152CU			152CMU	
		25	3/4		152.5CU			152.5CMU	
		30	3/4		153CU			153CMU	
		40	1		154CU			154CMU	
50	1 1/2	155CU	155CMU						
20,000	20	15	1/2	1 1/2	201.5CU	18" dia. x 36" deep	24" dia. x 36" deep	201.5CMU	36" dia. x 48" deep
		20	1/2		202CU			202CMU	
		25	3/4		202.5CU			202.5CMU	
		30	1		203CU			203CMU	
		40	1 1/2		204CU			204CMU	
50	2	205CU	205CMU						
25,000	25	15	1/2	1 1/2	251.5CU	18" dia. x 36" deep	24" dia. x 36" deep	251.5CMU	36" dia. x 48" deep
		20	1/2		252CU			252CMU	
		25	3/4		252.5CU			252.5CMU	
		30	1		253CU			253CMU	
		40	1 1/2		254CU			254CMU	
50	2	255CU	255CMU						
30,000	30	15	1/2	1 1/2	301.5CU	24" dia. x 36" deep	24" dia. x 36" deep	301.5CMU	42" dia. x 48" deep
		20	3/4		302CU			302CMU	
		25	3/4		302.5CU			302.5CMU	
		30	1		303CU			303CMU	
		40	1 1/2		304CU			304CMU	
50	2	305CU	305CMU						
40,000	40	15	3/4	1 1/2	401.5CU	24" dia. x 36" deep	24" dia. x 36" deep	401.5CMU	48" dia. x 48" deep
		20	3/4		402CU			402CMU	
		25	1		402.5CU			402.5CMU	
		30	1 1/2		403CU			403CMU	
		40	2		404CU			404CMU	
50,000	50	15	3/4	1 1/2	501.5CU	30" dia. x 36" deep	30" dia. x 36" deep	Not Available	
		20	1		502CU				
		25	1 1/2	502.5CU					
		30	1 1/2	503CU					
70,000	70	15	1 1/2	2	701.5CU	36" dia. x 36" deep	36" dia. x 36" deep	Not Available	
		20	1 1/2		702CU				
		25	2		702.5CU				
		30	2		703CU				
90,000	90	15	1 1/2	2	901.5CU	36" dia. x 36" deep	36" dia. x 36" deep	Not Available	
		20	2		902CU				
		25	3		902.5CU				
		30	3		903CU				

Receiver Size	Material	Receiver Warranty	Receiver Size	Material	Receiver Warranty
18X36	Epoxy Coated Steel	1year installation /18 months from date of ship	24X48	Epoxy Coated Steel	1year installation /18 months from date of ship
24X36	Epoxy Coated Steel	1year installation /18 months from date of ship	30X48	Epoxy Coated Steel	1year installation /18 months from date of ship
30X36	Epoxy Coated Steel	1year installation /18 months from date of ship	36X48	Epoxy Coated Steel	1year installation /18 months from date of ship
36X36	Epoxy Coated Steel	1year installation /18 months from date of ship	42X48	Epoxy Coated Steel	1year installation /18 months from date of ship
-	-	-	48X48	Epoxy Coated Steel	1year installation /18 months from date of ship

Domestic Series CU™ condensate units

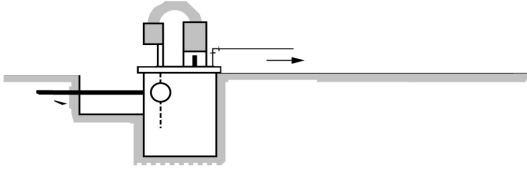

These units consist of an epoxy coated steel receiver, one or two pumps, and automatic float control. The pumps operate according to water level change in the receiver. Standard equipment is a heavy duty two-pole float switch on single units. A mechanical alternator is provided on duplex condensate pumps. On single phase pumps through two horsepower, the switch is factory wired.

In the selection table, you'll find that condensate pumps are pre-selected to deliver 1 gpm per 1000 EDR according to modern practice. This is twice the condensing rate and is the recommended rating.

Domestic Series CMU™ boiler feed units

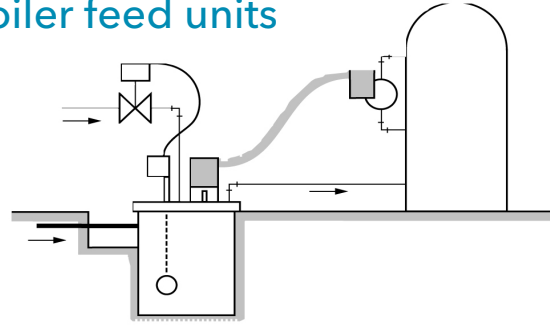

Underground boiler feed units consist of an epoxy coated steel receiver, one or two pumps, an automatic make-up valve, and overflow connection. A boiler feed unit is controlled from the water level in the boiler that it serves, not the level in its own receiver, so it must have a make-up valve in case there is no condensate present when the boiler needs water. Because the boiler feed unit must absorb surges in rate of condensate return, its receiver must be larger than that of a condensate unit; underground boiler feed units are pre-selected based on ten minutes storage. Pump controls are available as options.

The make-up valve is a float-switch-operated solenoid valve, with cushioned closing and epoxy resin encapsulated coil. Makeup water is added into the receiver to "temper" it, minimizing the danger of thermal shock to the boiler.

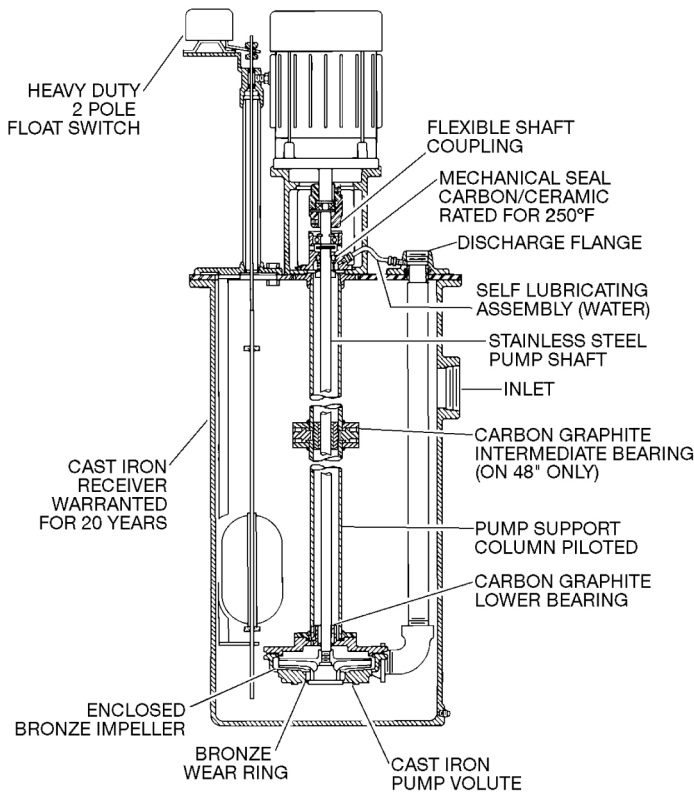

Note: TEFC and motors are available. A horsepower increase is not necessary using TEFC Motors.

STANDARD UNIT FEATURES:

- Receivers for condensate units are preselected for 1 minute net storage. Receivers for boiler feed units are pre-selected for 10 minute net storage.
- Steel Cover Plates, Duplex cover plates are split on 24" dia., 30" dia. and larger have individual pump mounting plates.
- Centrifugal Pumps, Series CU & CMU have standard centrifugal pumps. All pumps are sized 2 times system return rate.
- Level Control, Single condensate units have a heavy duty float switch. Duplex condensate units have a mechanical alternator to sequence pumps and provide automatic stand by on high level. Boiler feed units have a float switch and solenoid valve with Y strainer to add make up water on low level.

OPTIONAL FEATURES AVAILABLE:

- Stainless steel receiver.
- Inlet Basket Strainers; shipped separately; must be installed in pit area to provide servicing.
- Duplex Condensate units may be furnished with 2 float switches in lieu of mechanical alternator. Lead-Lag selector switches and electric alternator require 2 float switches.
- Control Panels, see page 4 for description.

ORDERING INSTRUCTIONS

Specify model number, single or duplex, phase, operating voltage, special features. On boiler feed units state number of boilers, type boiler control and describe function of control desired. See Bell & Gossett Specification 190B Domestic Pump Boiler Feed Control for boiler piping diagrams.

OPTIONAL ELECTRIC CONTROLS

Consolitol Control Cabinets are available to comply with NEMA specifications. Panels for underground units are furnished separately for wall mounting only.

Description of Optional Panel Components:

- Magnetic Starters must be used on all 3 phase motors and single phase motors 3 HP and larger.
- Disconnect Switches and Circuit Breakers. Either fuses or a circuit breaker is required ahead of the starter to protect against short circuits. A disconnect switch or circuit breaker also provides a means of shutting off power for service.
- Selector Switches. "Auto-Off-Hand" selector switches provide a means of shutting off pumps and a means of testing in the "Hand" position. "Off-Hand-Lead-Lag" selector switches may be furnished on duplex units with 2 float switches to provide manual alternation. Use only when magnetic starters are provided.
- Electric Alternator may be furnished on duplex units to provide automatic sequencing of lead pump. Use only when magnetic starters are provided and only with 2 float switches.

- Transformers are required to reduce control voltage when power supply exceeds 230 volts. Transformers are recommended when voltage exceeds 130 volts. Refer to local codes for requirements.
- Power Control Switching Relay is recommended when individual pump disconnect switches are specified and a control transformer is required. This relay maintains control power in the event pump #1's disconnect is turned off or pump #1 fails. In this event the control power will be automatically supplied by pump #2.
- Pilot Lights. Pump running pilot lights are available to indicate pump operation.
- An Audible Alarm to indicate high water level may be furnished on single units or in conjunction with a mechanical alternator on duplex units. A separate level control should be furnished to actuate alarm.

Specified panel Components to be furnished with unit at extra cost.

NEMA 2 - U.L. Listed Control Panels are the standard option when specified.

ROUGHING IN DIMENSIONS

not to be used for installation;
certified dimensions on request.

RECEIVER DIMENSIONS (INCHES)						RECEIVER CAPACITY-GALS.		
A	B	D	E	F	STANDARD INLET	FLOAT	TOTAL	
18	36	22	11	9	3	16	40	
24	36	28	14	9	4	25	71	
30	36	34	17	9	4	40	110	
36	36	40	20	9	4	57	158	

RECEIVER DIMENSIONS (INCHES)						RECEIVER CAPACITY-GALS.		
A	B	D	E	F	STANDARD INLET	FLOAT	TOTAL	
24	48	28	14	9	4	49	94	
30	48	34	17	9	4	77	146	
36	48	40	20	9	4	110	211	
42	48	46	23	9	6	150	288	
48	48	52	26	9	6	196	375	

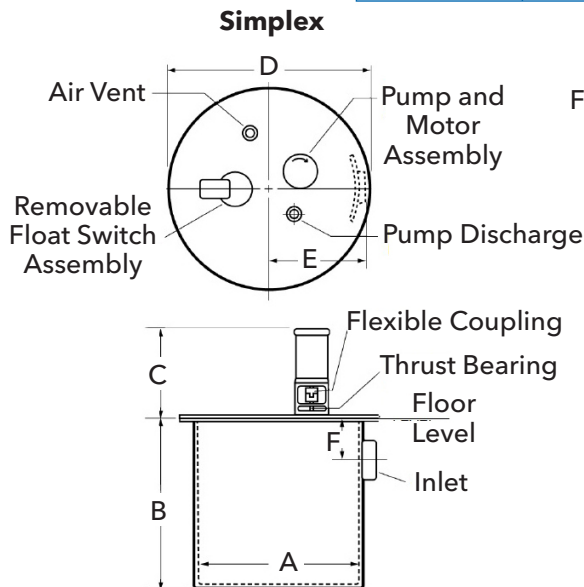

Allow B + C above floor to remove pump & motor assembly

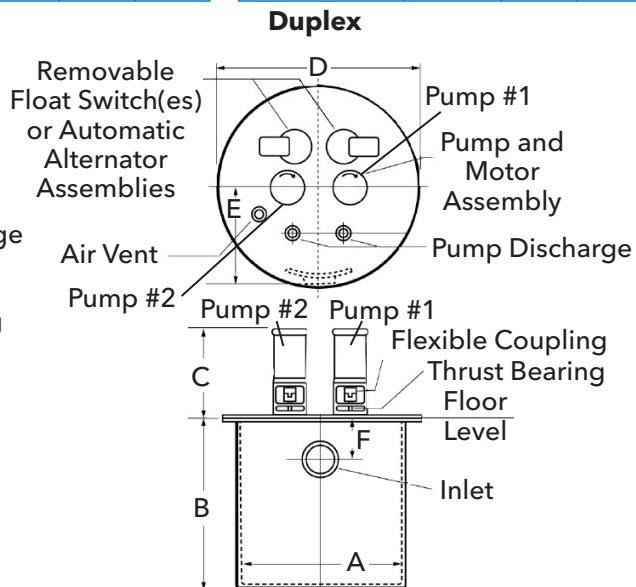

Allow B + C above floor to remove pump & motor assembly

Motor HP	3500 RPM	1/2 hp	3/4 hp	1 hp	1 1/2 hp	2 hp
Dimension	C (Inches)	16	17	17	19	19



Xylem Inc.
8200 N. Austin Avenue
Morton Grove, Illinois 60053
Phone: (847) 966-3700
Fax: (847) 965-8379
www.xylem.com/bellgossett

Bell & Gossett is a trademark of Xylem Inc. or one of its subsidiaries.
© 2020 Xylem Inc. S-230G February 2020