

# Domestic® Pump Vacuum Heating Units Series VCD™ and VCL™

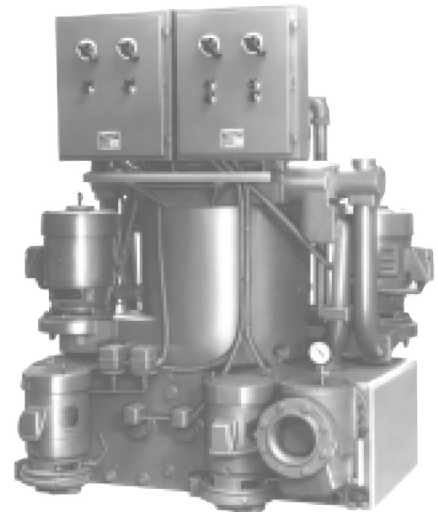
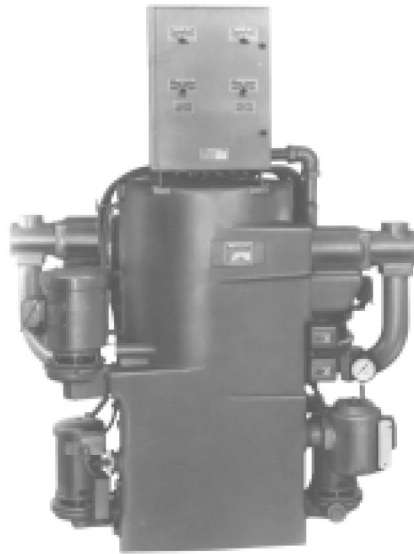

**INSTALLER:** PLEASE LEAVE THIS MANUAL FOR THE OWNER'S USE.

 **SAFETY INSTRUCTIONS**

This safety alert symbol will be used in this manual and on the unit safety instruction decals to draw attention to safety related instructions. When used, the safety alert symbol means **ATTENTION! BECOME ALERT! YOUR SAFETY IS INVOLVED! FAILURE TO FOLLOW THESE INSTRUCTIONS MAY RESULT IN A SAFETY HAZARD.**

If the decals as noted below are missing or are illegible contact your local B&G representative for a replacement.

1. Electrical connections to be made by qualified Electrician in accordance with all National, State and Local codes.
2. Motor must have properly sized starter with properly sized heaters to provide overload and undervoltage protection.
3. If pump, motor or piping are operating at extremely high or low temperatures, guarding or insulation is required.
4. Operating personnel should be trained in the operation of vacuum/condensate return units.



**EXPLOSIBLE**

**WARNING**

DO NOT PRESSURIZE TANK.  
ISOLATE TANK DURING LEAK TEST.  
DO NOT RESTRICT VENT.  
DO NOT PLUG OVERFLOW.  
OPEN INLET VALVES SLOWLY.  
DO NOT USE AS A FLASH TANK.

FAILURE TO FOLLOW INSTRUCTIONS COULD RESULT IN SERIOUS INJURY OR DEATH.

(2) All Units  
DN0483 (Small) - DN0484 (Large)



**WARNING**



**EXPLOSIBLE**

**ISOLATE TANK DURING LEAK TEST**

(2) All Units  
DN0485 (Small)  
DN0486 (Large)

™		
SERIES HV™		
MODEL		
SERIAL		
GPM	PSI	PUMP
CFM	IN HG.	PUMP
DWGS		
POWER V.	PH.	HZ 60
CONTROL V.	PH. 1	HZ 60
TOTAL FL. AMP	LARGEST MOTOR FL. AMP	
<b>Bell &amp; Gossett</b> <small>Morton Grove, Illinois 60053</small>		

DN0016 Bell & Gossett  
Morton Grove, Illinois 60053  
**DN0116 Units with Panel**



**CAUTION**

DO NOT RUN PUMP DRY. SEAL DAMAGE MAY OCCUR.  
INSPECT PUMP SEAL REGULARLY FOR LEAKS, REPLACE AS REQUIRED.  
FOR LUBRICATION REQUIREMENTS, CONSULT SERVICE INSTRUCTIONS.  
FAILURE TO FOLLOW INSTRUCTIONS COULD RESULT IN INJURY OR PROPERTY DAMAGE.

P70644

**P70644 All Units**



### PIPING (Returns)

Gravity return lines from system must be properly pitched down to unit inlet. Returns must also be trapped to prevent steam entry into the unit. An inlet basket strainer is recommended.

### SUCTION PIPING

Suction piping between the condensate receiver and the vacuum producer should be at least as large as the inlet to the vacuum producer.

### PIPING (Vent)

Install a vent pipe to atmosphere. Pipe to be size of vent port on unit. Do not restrict or reduce vent opening or exceed 20 feet vertical height unless an overflow connection is provided.

### PIPING (Overflow)

Pipe overflow port to drain using an overflow loop when condensate temp will exceed 200°F. (93°C).

The overflow port on the hurling chamber acts as the overflow for both the vacuum producer and condensate return units. Pipe to a suitable drain.

Series VCL units have a high level (overflow control) float switch to start the vacuum pumps when the lower receiver is at the "full" level. The vacuum pumps will siphon condensate from the receiver into the hurling chamber.

Excess condensate will then overflow out of the hurling chamber to drain.

### FLOAT SWITCHES & MECHANICAL ALTERNATORS

Floats are locked in place to prevent damage during shipment. Remove shipping locks. Check factory settings. Floats and mechanical alternators are adjustable for various levels of operation. The lead pump should start with tank <sup>3</sup>/<sub>4</sub> full and shut off at 2" or more above pump inlet. Lag pump should start before the tank overflows. Settings should avoid "short cycling" of the pump.

Vacuum switch adjustment is explained on the following page. An electric alternator (when furnished) must operate off the lead vacuum switch.

### ELECTRICAL WIRING & CONTROLS

Connect power wiring per the National Electrical Code. Recheck nameplate vs specifications and conditions. All single phase motors have internal thermal protection.



#### **WARNING: HIGH VOLTAGE ELECTRICITY**

Disconnect and lock out power before connecting or servicing unit. Failure to follow these instructions could result in serious injury or death.

Three phase motors must use starters with properly sized overload relays. Overload relays furnished are designed for manual reset.

### EQUALIZING LINE

A vacuum may be formed on radiation side of system when steam stops flowing in mains. This vacuum may be higher than return line vacuum, which would prevent condensate from flowing back to pump. To correct this in an unzoned system, install equalizer line as shown. To correct this in a zoned system, install a vacuum breaker on supply line on radiation side of each zone valve.

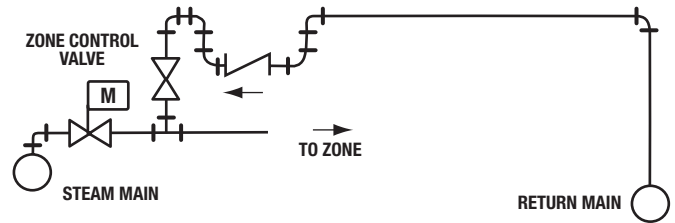

**FIG. 2 EQUALIZING CONNECTIONS FOR ZONED SYSTEMS**

### ACCUMULATOR TANK

An accumulator tank may be used to facilitate lifting condensate. The accumulator tank will be fitted with a float switch to start the vacuum pump as accumulator fills. The vacuum pump will then siphon condensate into the condensate receiver.

The vacuum sensor line in an accumulator tank system must sense the vacuum in the accumulator tank as shown on the low return piping diagrams. (Figure 9, page 5.)

## SEQUENCE OF OPERATION

There are two separate and independent cycles of operation in the VCD design – one of air evacuation and the other for condensate return. This is accomplished by completely separating the air pumps from the condensate storage receiver and water pumps. Fig 3 below illustrates a single, two compartment receiver, divided horizontally, where the air pumps operate from the upper compartment or separation chamber while the water pumps operate from the lower compartment or condensate receiver. The unit below is similar except that the air pump separation chamber and condensate receiver are separate units, connected as shown in Figure 4. The operation for both types of construction is identical.

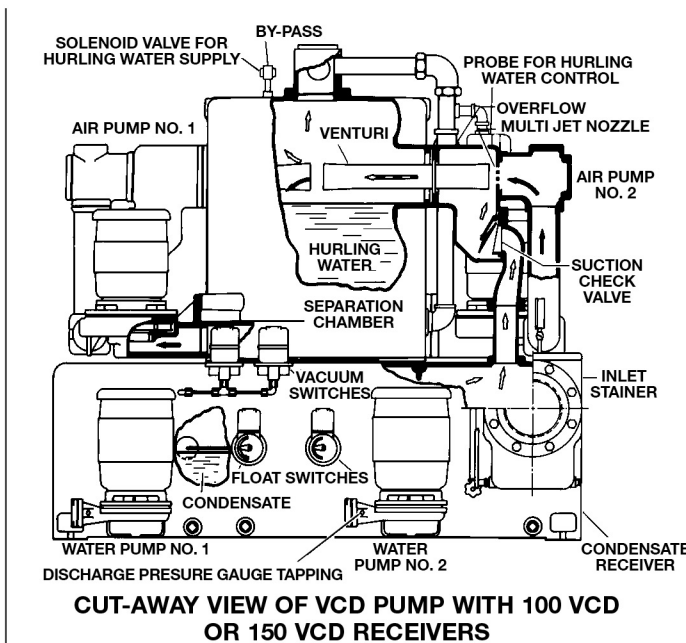
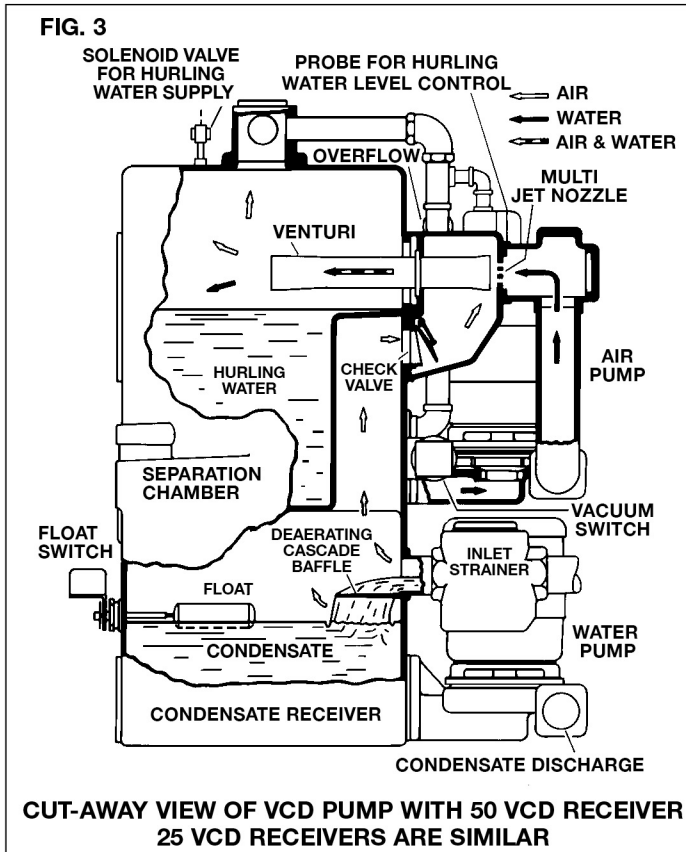

## AIR EVACUATION CYCLE

The independent air evacuation cycle begins when the vacuum switch, responding to system requirements, starts the centrifugal "air" pump. This pump circulates "hurling" water from the separation chamber through the multi-jet nozzle, venturi and returns it to the separation chamber. The water, forced at high velocity across the gap between nozzle and venturi, entrains air and gases in multiple jet streams, creating a smooth, steady vacuum in the condensate receiver and system. The mixture is discharged through the venturi into the separation chamber where the air and gases separate from the "hurling" water and are vented. When the desired vacuum has been produced in the system, the vacuum switch stops the pump, and the check valve at air inlet to separation chamber closes, preventing the return of air to the system.

Replacement of the hurling water evaporated from the separation chamber is controlled by a solenoid valve connected to the water supply and actuated by a float switch.

## CONDENSATE RETURN CYCLE

The condensate return cycle begins when a float switch starts a water pump on condensate rise. The condensate is pumped into the boiler feed system until the preset low float switch setting has been reached.

## DUPLEX PUMPS

The second or lag pump of duplex water and/or air pumps functions if the first or lead pump fails and automatically operates to double the capacity in the event of abnormal demand.

## TEMPERATURE LIMIT SWITCH

Some units may be equipped with temperature limit switches. When located on the separation chamber, it is used to admit cooling water if the hurling temperature exceeds a predetermined limit.

A condition may be encountered where the temperature of the condensate fluctuates intermittently to critically high levels, where operation under vacuum could cause the condensate to vaporize. A temperature limit switch can be installed on the condensate receiver to prevent the air pump(s) from operating where such a condition exists. Upon temperature drop the vacuum switch(es) will again control operation of the air pump(s).

## VACUUM SWITCH ADJUSTMENTS

The vacuum switches are adjusted and tested at the factory for proper operation. The vacuum switch on the single unit and the lead switch of the duplex unit is set to close at 3" Hg vacuum and open at 8". The lag switch of a duplex unit is set to close at 2" and open at 8".

These settings are suitable for all normal installations including those having an accumulator tank or lift fitting when properly piped. If settings must be readjusted, refer to manufacturer's instruction.

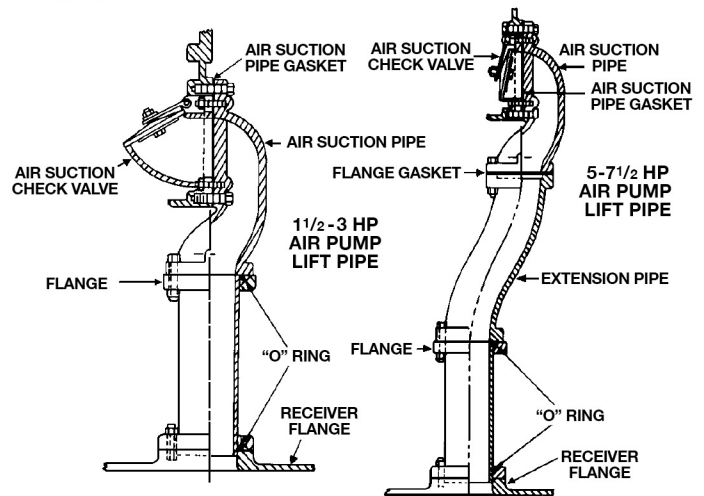

**FIG. 4 100 & 150 VCD LIFT PIPE ASSEMBLIES**

# SPECIAL PIPING ARRANGEMENTS FOR LOW RETURNS (IF LIFT EXCEEDS 5 FEET, A MECHANICAL LIFT IS RECOMMENDED)

CONNECTIONS TO VACUUM UNIT WHERE HEATING UNITS ARE ABOVE THE WATER LINE OF BOILER AND A SECTION OF THE RETURN IS BELOW THE PUMP INLET

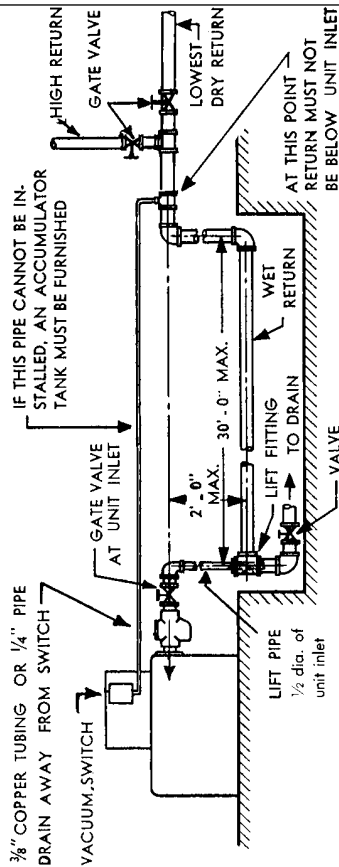

**FIG. 5**

RETURNS BELOW UNIT INLET (NO ACCUMULATOR TANK) VACUUM PUMP TO RUN CONTINUOUSLY.

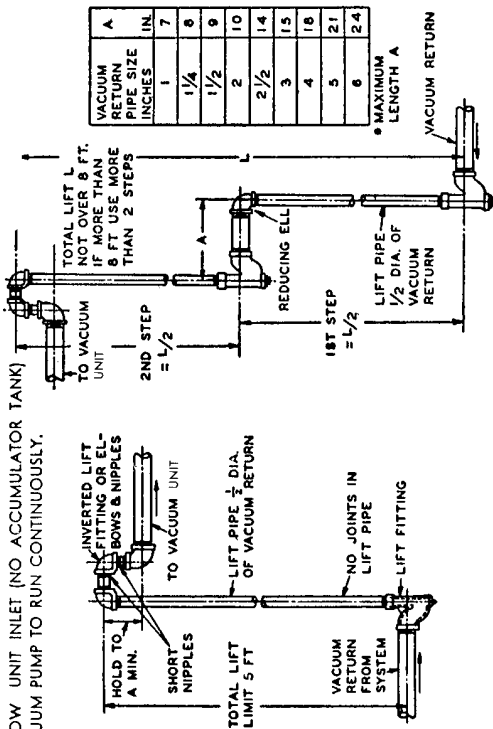

**FIG. 7** CONSTRUCTION OF A STEP LIFT

**FIG. 6** METHOD OF CONSTRUCTING A LIFT IN A RETURN LINE

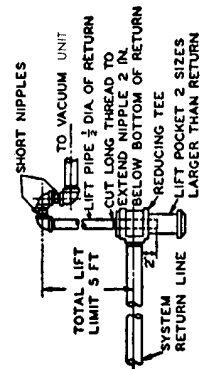
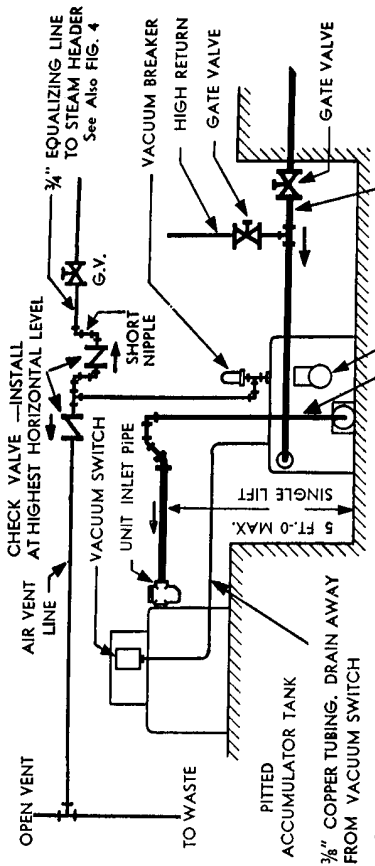

**FIG. 8** HOW TO BUILD A LIFT FITTING

Note—A valve or cock is recommended to drain lift fitting.

LIFT PIPE DETAIL reprinted by Permission FROM HEATING, VENTILATING, AIR CONDITIONING GUIDE, 1957.

PIPING TO VACUUM UNIT WHERE RETURN MAIN IS BELOW PUMP FLOOR LEVEL WITH CONNECTIONS TO PITTED AND VERTICAL UNDERGROUND ACCUMULATOR TANKS.



**FIG. 9**

RETURNS BELOW UNIT INLET (NO ACCUMULATOR TANK) VACUUM PUMP TO RUN CONTINUOUSLY.

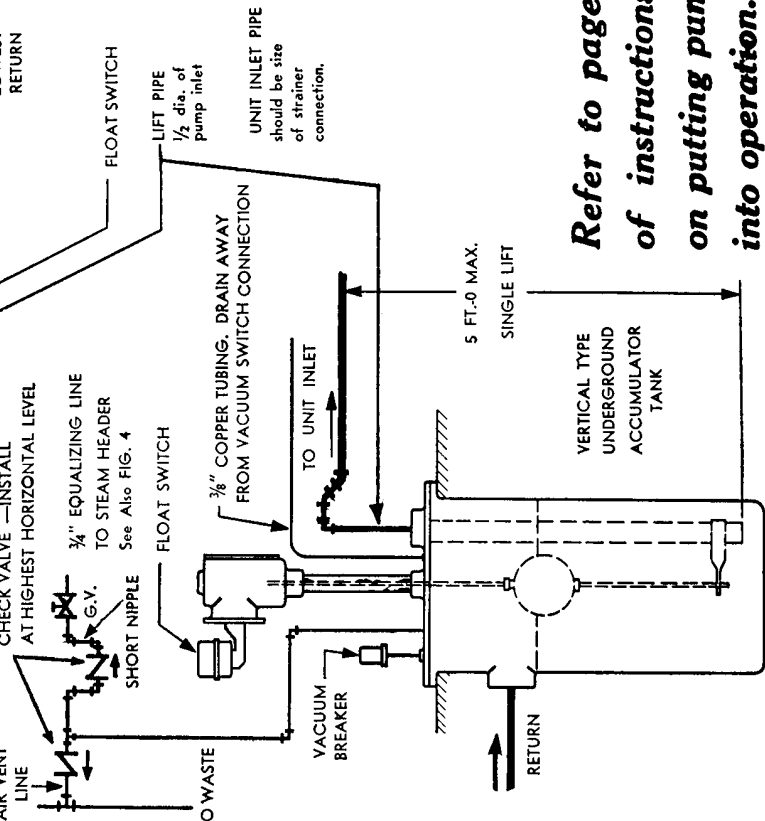

**FIG. 10**

**Refer to page of instructions on putting pump into operation.**

## PUTTING THE VACUUM PRODUCER INTO SERVICE

 **WARNING: AVOID REACTIVE CHEMICALS**  
Avoid drawing explosive, flammable, highly corrosive or otherwise highly reactive liquids or vapors into the hurling chamber. Failure to follow these instructions could result in serious injury, death or extensive property damage.

 **WARNING: EXPLOSIBLE**  
Do not pressurize receiver. Isolate receiver during leak test. Do not plug overflow. Do not restrict vent opening to atmosphere. Open valves slowly. Failure to follow these instructions could result in serious injury or death.

1. Assure that the unit is piped in accordance with instructions and diagrams.  
Confirm that incoming power agrees with ratings of motors and that wiring diagrams (when furnished) match specifications and job requirements.  
A variety of control options are available. Refer to the wiring diagram (when furnished) for information on electrical controls.
2. Isolate tank before performing any system leak test. Do not pressurize the tank as part of the leak test. Failure to do this can result in serious injury or death.
3. Check floats and make-up solenoid for proper operation.
4. Check power leads in accordance with wiring diagram enclosed in control cabinet (when furnished).

 **WARNING: HIGH VOLTAGE**  
Disconnect and lock out power before connecting or servicing unit. Failure to follow these instructions could result in serious injury or death.

5. Install drain plugs.
6. Fill receiver half full of water to prime pump(s) and prevent possible damage to pump seals. Avoid freezing conditions after unit receiver has been filled.
7. Check for proper rotation of all three phase motors. Rotation must be clockwise looking down on the motor as indicated by directional arrow on pump casting. If pump runs backwards,

 **CAUTION: DO NOT REVERSE**  
Reverse operation can cause extensive damage to pumps. Jog the motor to test for direction of rotation. Failure to follow these instructions could result in injury or property damage.

 **CAUTION: DO NOT RUN DRY.  
SEAL DAMAGE MAY OCCUR.**  
Inspect pump seal regularly for leaks. Replace as required. Failure to follow these instructions could result in injury or property damage.

interchange two wires (3 phase only).

Vacuum switches are factory set per job specifications and readjustment should not be necessary. Refer to switch manufacturer's literature for details of adjusting procedure. If resetting is required, it is helpful to disconnect wiring and set one switch at a time. The "lead" switch must make and break at a slightly deeper vacuum than the "lag" switch.

The electric alternator (when provided) must always operate from the lead vacuum switch.

An optional temperature limit switch may be provided to add cooling water to the hurling chamber when hurling water temperature rises above 160°F or to cut out the vacuum pumps when the return condensate temperature rises above 180°F. These are provided to improve vacuum efficiency or to protect the vacuum pumps from damage. The switch should close on rising temperature.

Remove start-up label (below) from panel (if applicable) after complying with instructions.

### ELECTRICIAN/INSTALLER/OPERATOR

- REMOVE AND DESTROY THIS TAG AFTER —
1. ASSURING THAT ALL PUMPS ROTATE CLOCKWISE PER ARROWS CAST ON VOLUTES. (JOG PUMP MOMENTARILY TO TEST — INTERCHANGE ANY TWO MOTOR POWER WIRES TO REVERSE 3PH MOTORS.)
  2. ASSURING THAT SHIPPING LOCKS HAVE BEEN REMOVED FROM ALL FLOAT SWITCHES.

## PUTTING THE CONDENSATE PUMPS INTO SERVICE

1. Assure that the unit is piped in accordance with instructions.

 **WARNING: EXPLOSIBLE**  
Do not pressurize receiver. Isolate receiver during leak test. Do not plug overflow. Do not restrict vent opening to atmosphere. Open valves slowly. Failure to follow these instructions could result in serious injury or death.

2. Isolate tank before performing any system leak test. Do not pressurize the tank as part of the leak test. Failure to do this can result in serious injury or death.
3. Check floats and alternators for free operation.
4. Check power leads in accordance with wiring diagram enclosed in control cabinet (when furnished).

 **WARNING: HIGH VOLTAGE**  
Disconnect and lock out power before connecting or servicing unit. Failure to follow these instructions could result in serious injury or death.

5. Install drain plugs.
6. Fill receiver half full of water to prime pump(s) and prevent possible damage to pump seals. Avoid freezing conditions after unit receiver has been filled.
7. Check for proper rotation of all three phase motors. Rotation must be clockwise looking down on the motor as indicated by directional arrow on pump casting. If pump runs backwards, interchange two wires (3 phase only).

 **CAUTION: DO NOT REVERSE**  
Reverse operation can cause extensive damage to pumps. Jog the motor to test for direction of rotation. Failure to follow these instructions could result in injury or property damage.

8. Throttle plug cock in discharge line until pressure at pump (while pump is discharging) approaches pump rated pressure. Tighten plug nut to secure adjustment.

 **CAUTION: DO NOT RUN DRY.  
SEAL DAMAGE MAY OCCUR.**  
Inspect pump seal regularly for leaks. Replace as required. Failure to follow these instructions could result in injury or property damage.

9. Remove start-up label (below) from panel (if applicable) after complying with instructions.

### ELECTRICIAN/INSTALLER/OPERATOR

- REMOVE AND DESTROY THIS TAG AFTER —
1. ASSURING THAT ALL PUMPS ROTATE CLOCKWISE PER ARROWS CAST ON VOLUTES. (JOG PUMP MOMENTARILY TO TEST — INTERCHANGE ANY TWO MOTOR POWER WIRES TO REVERSE 3PH MOTORS.)
  2. ASSURING THAT SHIPPING LOCKS HAVE BEEN REMOVED FROM ALL FLOAT SWITCHES.

10. If possible, observe operation thru several cycles.

## OPERATION AND MAINTENANCE

Operators must be familiar with all sections of this manual to understand the operation of the unit.

Hot water, steam and electricity can be hazardous.

**SAFETY INSTRUCTIONS**  
SEE COVER OF THIS MANUAL

**WARNING: EXPLOSIBLE**  
Do not pressurize receiver. Isolate receiver during leak test. Do not plug overflow. Do not restrict vent opening to atmosphere. Open valves slowly. Failure to follow these instructions could result in serious injury or death.

**WARNING: HIGH VOLTAGE**  
Disconnect and lock out power before connecting or servicing unit. Failure to follow these instructions could result in serious injury or death.

Check motor nameplate for any lubrication requirements. Pumps require no lubrication.

### NOTICE/AUTO RESTART

Single phase motors will restart automatically after thermal overload protector trips.

Overload thermal relays in starters must be reset manually.

A properly installed unit should function unattended for long periods of time. Periodic checks to assure proper operation are highly recommended. Refer to trouble shooting section when necessary.

Frequent starting and stopping of the pumps (short cycling) is a symptom of system problems and will lead to premature failure of the vacuum producer. See Trouble Shooting procedures.

A variety of control options are available and are furnished in accordance with user specifications. Refer to wiring diagrams (when furnished) to determine control switch settings.

The inlet strainer (when furnished) is intended to protect the pump and system. Periodic cleaning should be included in the maintenance schedule. Check frequently in new systems.

**CAUTION: SUBSEQUENT DAMAGE**  
A unit showing symptoms of possible problems (overflow, noise, leaks, vibrations, continual operation, etc.) must be corrected immediately. Failure to follow these instructions may result in full liability for subsequent injury or property damage.

### GAGE GLASS MAINTENANCE (Vented Systems)

Clean gage glass as required using commercial glass cleaner. Dilute muratic acid may be used if required (observe handling precautions). Never clean gage glass with wire brushes, scrapers or harsh abrasives.

Do not reuse gage glass or packing or seals.

Immediately replace glass which is broken, cracked, chipped, scratched or otherwise damaged. Inspect periodically with a bright concentrated light. Anything which glistens and catches the fingernail or any star-shaped or crescent-shaped mark which glistens is cause for replacement. Any gage glass which appears cloudy or roughened and will not respond to cleaning procedures should be replaced.

When replacing gage glass, use new packings specified for this use. Install glass with sufficient end clearance for expansion (keep glass to metal clearance at each end) and tighten nuts just enough to avoid leakage (do not over tighten).

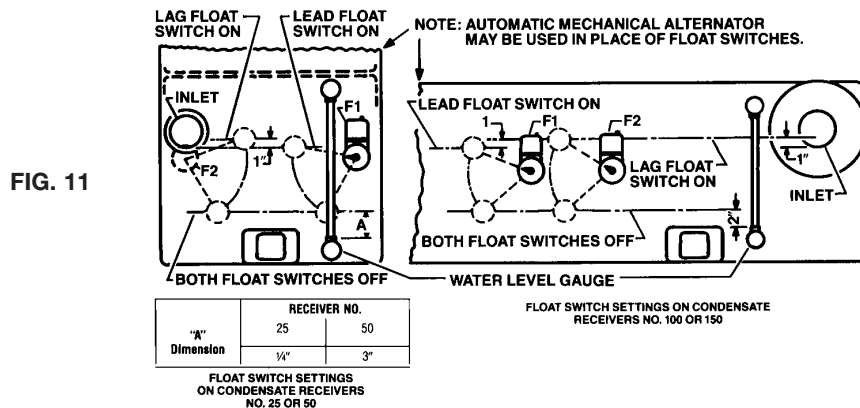

## FLOAT SWITCH SETTINGS

Float switches and mechanical alternators are factory adjusted and tested for proper operation. Shipping brackets on these switches are used to preserve these adjustments while pump is in transit. Remove these brackets before putting pump into operation. If adjustments are disturbed for any reason they can be correctly reset as follows:

### ADJUSTMENT OF FLOAT SWITCHES IN CONDENSATE RECEIVER

1. Close inlet gate valve and operate water pump on "Hand" to remove water to the low level dimensioned.
2. Adjust cut-off point of float switch F1 so that switch opens at low level shown. Both switches of duplex units should open at same low level (See switch manufacturer's instructions). Set selector switches to OFF.
- 3a. (One float switch in condensate receiver). Fill lower compartment thru strainer. Remove drain plug from strainer. When water stops flowing from drain opening, adjust cut-in point of float switch by depressing float arm slightly and setting adjusting strip so that switch turns on when float arm is released.

- 3b. (Two float switches in condensate receiver). Adjust the F1 or lead float switch as described in 3a. Adjust cut-in point of second or stand-by switch F2 at a level 1" higher than F1.

### ADJUSTMENT OF MECHANICAL ALTERNATOR

2. Fill lower compartment thru strainer. Remove drain plug from strainer. When water stops flowing from drain opening, set upper adjusting strip by depressing float arm with operating level so that both sets of contacts close when operating lever is lowly released. (See switch manufacturer's instructions).
3. Set the lower adjusting strip for minimum differential (no lost motion of adjusting plate). Set selector switches to AUTOMATIC. When adjustments have been properly made, both pumps will automatically shut off at the proper level.

### HURLING WATER CONTROL FLOAT SWITCH ON SEPARATION CHAMBER

The switch is factory adjusted and does not require field settings.

## HURLING CHAMBER FLOAT SWITCH ADJUSTMENT

The switch which controls the hurling water makeup valve is located inside the float housing near the vacuum unit overflow.

The switch is under a triangular coverplate which is retained by one #6 screw (loosen bolts retaining the cover edges only if necessary). The actuating cam can be rotated for testing by using a screwdriver in the slot provided.

Adjust the switch location so that the switch snaps at approximately mid-range of the cam travel. The #6 screw near the cam goes thru a slot in the switch mounting plate. Loosen this

screw (and farthestmost screw thru the switch) to permit adjustment of the switching position. Tighten screws and recheck operation after making any adjustment.

The cam should be positioned on the shaft for maximum switch roller movement in operation. The cam is retained by a socket set screw.

Replacement seal tube assemblies are available in case of leakage around the float pivot shaft.



## CONTROL PANEL SELECTOR SWITCH SETTINGS

Pump	Model	Position	Purpose	Operation	
WATER	VCD 2	Automatic	Normal.	Pump starts on high condensate level, stops on low.	
		Off	Adjust controls, inspect pump.	Prevent operation of motor. Caution: See footnote 1.	
	VCD 3 and VCD4	Lead Lag	Set one switch to "lead", other to "lag". Reverse periodically.	Lead pump starts first on high condensate level, lag pump runs in emergency.	
		Off	Adjust controls, inspect pump.	Prevent operation of motor. Caution: See footnote 1.	
	Any	Hand	Test rotation and/or pressure.	Caution – Pump may run dry and damage seal.	
AIR	VCD 2 and VCD 3	Automatic	Normal.	Pump starts on low vacuum, stops on high vacuum.	
		Off	Sometimes right or week-end. <sup>2</sup>	Unit operates as a simple condensation pump.	
		Continuous	Testing or high lifts in returns.	Pump operates continuously.	
	VCD 4	Off	Sometimes right or week-end. <sup>2</sup>	Unit operates as a condensation pump.	
		Lead Lag	Set one switch to "lead", other to "lag". Reverse periodically.	Lead pump starts first on low vacuum, lag pump also runs on start up or with large system leaks.	
		Continuous	Testing or high lifts in returns.	Air pump runs continuously.	
AIR WITH ACCUMULATOR <sup>3</sup>	VCD 2	Float & Vacuum	Normal.	Pump starts on high condensate level or low vacuum. <sup>4</sup>	
		Float Only	Sometimes night or week-end. <sup>2</sup>	Air pump responds only to condensate level change.	
	VCD 3	Continuous	Testing or high lifts in returns.	Pump operates continuously.	
	VCD4	Off	Adjust controls, inspect pump.	Prevent operation of motor. Caution: See footnote 1.	
	VCD 4 Only	No. 1 pump leads	Set one switch to "lead", other to "lag". Reverse periodically.		Lead pump starts first on float and/or vacuum depending on setting of other vacuum pump selector switch.
		No. 2 pump leads			

<sup>1</sup> Caution – this is not a disconnect switch for power supply.

<sup>3</sup> Air pumps respond to conditions in accumulator tank.

<sup>2</sup> Not recommended for systems with lift fittings.

<sup>4</sup> Duplex air pump runs on abnormally high rate of condensate flow, and on start-up.

## PUMP SERVICE INSTRUCTIONS MODEL FOR 609PF CENTRIFUGAL PUMPS ONLY

These closed coupled vertical centrifugal pumps are equipped with mechanical seals. If system has not been properly cleaned prior to installation of pump, foreign matter such as dirt, pipe scale, core sand, etc. may clog the impeller and damage the seal. A strainer is recommended in return line to pump. *Pump must not be operated dry.* Seals may be damaged if operated without water present.

1. Close inlet line gate valve and operate pump momentarily to remove as much liquid as possible from pump. Close discharge line gate valve.

### **CAUTION: HOT SURFACES**

Surfaces are hot when system is in operation. Do not touch hot receiver, let unit cool before servicing. Failure to follow these instructions could result in injury or property damage.

2. Shut-off and lock out power.

### **WARNING: HIGH VOLTAGE**

Disconnect and lock out power before connecting or servicing unit. Failure to follow these instructions could result in injury or property damage.

3. Disconnect wiring to motor.
4. Make sure unit is cool enough that pump can be handled safely. Open receiver drain to remove remaining liquid.
5. Loosen the motor to pump volute fasteners. Assure that pressure is relieved per caution note.

### **CAUTION: PRESSURIZED SYSTEM**

Operating system may contain very hot water under pressure. Close inlet and open drains before servicing. When servicing, *loosen screws* and move components to assure pressure is relieved before *removing screws*. Keep drains open during servicing. Failure to follow these instructions could result in injury or property damage.

6. Remove four capscrews (7) holding pump case to motor and lift motor and impeller out of pump case.
7. Remove pump/motor assembly and place on work bench.
8. Hold top end of motor shaft with large screwdriver via screwdriver slot in shaft and back off impeller (counter-clockwise) with a rectangular bar or other flat tool inserted between vanes of the impeller.
9. Remove the rotating part of the mechanical seal from the end of the shaft.
10. Remove seal holder (2) with stationary ceramic part of mechanical seal and cup rubber from the end of the shaft.
11. Remove stationary ceramic part of mechanical seal and cup rubber from recess in seal holder.
12. To install new seal proceed as follows: Clean recess in seal holder thoroughly. Orient motor so that conduit opening on motor is left when looking at motor shaft. Replace seal holder on the face of the motor maintaining concentricity with motor face. Place new ceramic part of seal in the cup rubber over motor shaft and press firmly into recess of seal holder by hand, making certain both parts bottom evenly. If assembly cannot be bottomed with fingers place a wooden or cardboard tube over shaft onto ceramic and push into place. Using a clean, lint-free cloth, wipe the mating surfaces of the seal clean of any foreign matter. Moisten the carbon section of the rotating part of the seal and place onto shaft to seat against ceramic. Place seal spring on to shaft.
13. Hold motor shaft as described in #8 and replace the impeller on the shaft (clockwise rotation) making sure it is tight.

**FIG. 12**  
2DPF01

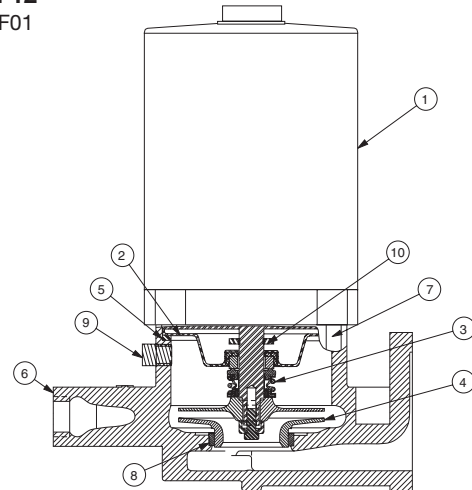

- |                |                               |              |
|----------------|-------------------------------|--------------|
| 1. Motor       | 5. Gasket                     | 8. Wear Ring |
| 2. Seal Holder | 6. Case                       | 9. Pipe Plug |
| 3. Seal        | 7. Capscrew (motor to volute) | 10. Slinger  |
| 4. Impeller    |                               |              |

14. Orient motor for pump reassembly with conduit opening to the left. When mounting the pump case, discharge should be 90° to the right of conduit opening on motor. Use care to insure tight gasket fit to prevent water leakage.
15. Replace four capscrews (7). Tighten down capscrews evenly to avoid damage.
16. Reconnect pump bleed line (where applicable) and motor wiring.
17. Close drain and slowly open inlet valves. See warning.



### **CAUTION: DO NOT RUN DRY. SEAL DAMAGE MAY OCCUR.**

Inspect pump seal regularly for leaks. Replace as required. Failure to follow these instructions could result in injury or property damage.

18. Jog to check motor rotation. See caution.



### **WARNING: EXPLOSIBLE**

Do not pressurize receiver. Isolate receiver during leak test. Do not plug overflow. Do not restrict vent opening to atmosphere. Open valves slowly. Failure to follow these instructions could result in serious injury or death.

19. Observe operation thru several cycles.



### **CAUTION: DO NOT REVERSE**

Reverse operation can cause extensive damage to pumps. Jog the motor to test for direction of rotation. Failure to follow these instructions could result in injury or property damage.

# PUMP SERVICE INSTRUCTIONS MODEL FOR CENTRIFUGAL PUMPS

## Vertical mounting puts motor above floor dirt and water

Closed coupled centrifugal pumps are designed for years of trouble free service. Units have mechanical shaft seals.

1. Close inlet line gate valve and operate pump momentarily to remove as much liquid as possible from pump. Close discharge line gate valve.

### **CAUTION: HOT SURFACES**

Surfaces are hot when system is in operation. Do not touch hot receiver, let unit cool before servicing. Failure to follow these instructions could result in injury or property damage.

2. Shut-off and lock out power.

### **WARNING: HIGH VOLTAGE**

Disconnect and lock out power before connecting or servicing unit. Failure to follow these instructions could result in injury or property damage.

3. Make sure unit is cool enough that pump can be handled safely. Open receiver drain to remove remaining liquid.
4. Carefully remove pump drain plug and bleed line. Wait for complete drainage.
5. Loosen the motor bracket to pump volute capscrews. Assure that pressure is relieved per caution note.

### **CAUTION: PRESSURIZED SYSTEM**

Operating system may contain very hot water under pressure. Close inlet and open drains before servicing. When servicing, *loosen screws* and move components to assure pressure is relieved before *removing screws*. Keep drains open during servicing. Failure to follow these instructions could result in injury or property damage.

6. Complete the removal of the above hardware. Remove pump/motor assembly and place on work bench.
7. Remove self locking stainless steel capscrews and stainless steel washer (or self locking brass cap nut and washer) that secure the impeller in place.
8. To remove impeller from motor shaft proceed as follows:
  - (1) Keyed Shafts. Remove impeller with gear puller or other means which will not damage impeller or bend motor shaft.
  - (2) Threaded Shafts. Hold end of motor shaft opposite pump with large screwdriver or other suitable tool and back impeller off with a rectangular bar or other flat tool inserted between the vanes of the impeller.
9. Remove the rotating part of seal from shaft, being careful not to break carbon face.
10. Remove capscrews holding motor bracket to motor and remove bracket.
11. Remove stationary part of seal assembly, being careful not to chip or break ceramic seal.
12. To install new seal proceed as follows:
  - (1) Clean recess in bracket thoroughly. Coat recess and "rubber" portion of seat with soap solution. Press seat into recess firmly by hand making certain both parts bottom evenly. If seal cannot be bottomed with fingers place cardboard shipping disc on ceramic and force into place with flat tool.
  - (2) Carefully place bracket in position on motor shaft without displacing ceramic seat and secure bracket to motor with capscrews.
  - (3) Place motor vertically with pump end up. Do not attempt assembly of seal and impeller with shaft horizontal.

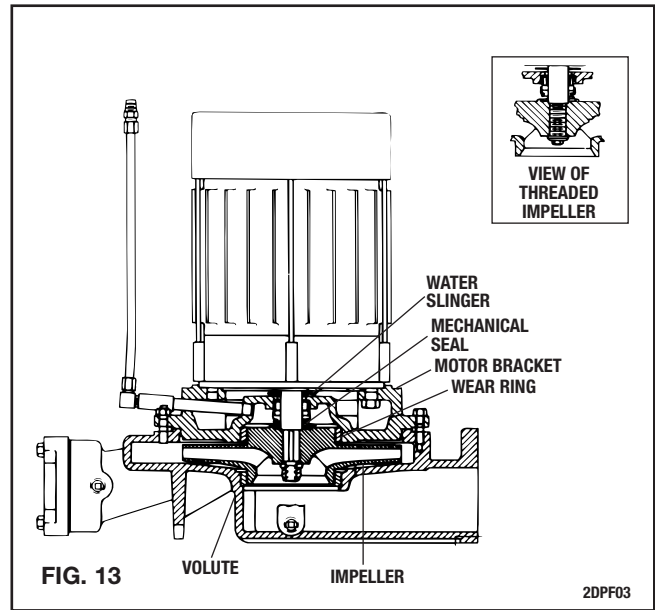

- (4) The carbon of rotating part of seal should not be loose. If it is, hold in place with grease. Using clean, lint free cloth, wipe mating surfaces perfectly clean. Soap shaft and push seal onto shaft so that carbon will contact ceramic seal. If spacer is required, use grease to cause spacer to adhere to bottom of seal after seal has been put on shaft. Be sure spacer is on larger diameter of shaft so that it will not catch between shoulder and impeller.

13. Replace impeller on shaft. Replace stainless steel washer and secure impeller with capscrew or cap nut.
14. Place new gasket on pump volute and reassemble motor and pump subassembly on pump volute.
15. Reconnect pump bleed line and motor wiring.



### **CAUTION: DO NOT RUN DRY. SEAL DAMAGE MAY OCCUR.**

Inspect pump seal regularly for leaks. Replace as required. Failure to follow these instructions could result in injury or property damage.

16. Close drain and slowly open inlet valves. See warning.



### **WARNING: EXPLOSIBLE**

Do not pressurize receiver. Isolate receiver during leak test. Do not plug overflow. Do not restrict vent opening to atmosphere. Open valves slowly. Failure to follow these instructions could result in serious injury or death.

17. Jog to check motor rotation. See caution.



### **CAUTION: DO NOT REVERSE**

Reverse operation can cause extensive damage to pumps. Jog the motor to test for direction of rotation. Failure to follow these instructions could result in injury or property damage.

18. Observe operation thru several cycles.

## TROUBLESHOOTING PROCEDURES – VACUUM PRODUCER

All units are thoroughly tested at the factory before shipment. They should operate satisfactorily without further adjustment if properly installed and providing they have not been damaged by rough handling in transit. If system or unit performance is not satisfactory, refer to the following check list.

### PUMP WILL NOT START

1. The power supply has been interrupted, disconnect switch is open or selector switch is improperly positioned.
2. Incorrect voltage for motor. Check voltage and wiring with motor characteristics.
3. Incorrect starter coil for power supply.
4. The overload relays in the starter have tripped out and must be reset. Ambient temperature may be too high.
5. Check pump controls or other controls for proper operation.
6. Wiring to control cabinet is incorrect or connections are loose.
7. The system has vacuum and vacuum switches are open.

### PUMP RUNS CONTINUOUSLY

1. Pump is running backward. Rotation of three phase motors may be corrected by interchanging any two of the three wires. Rotation should be clockwise looking down on motor.
2. System flow or leaks prevent the unit from developing design vacuum. Vacuum system must be tight.
3. System is drawing vacuum greater than the vapor pressure of a liquid – the liquid is being boiled and then condensed in the vacuum unit.
4. Holes in the nozzle plate are plugged and the system will not develop vacuum. Inspect and clean nozzle plates.

5. Incorrect liquid level in the hurling chamber (flooded or empty).
6. Improper vacuum switch adjustment or selector switch in “continuous” position.
7. Hurling water level incorrect.

### SYSTEM OVERFLOWS

1. System may be normal. Cooling water is required to lower vapor pressure of hurling water to be able to draw deep vacuum.
2. Temperature limit switch is set lower than required and adds unnecessary water.
3. The design vacuum is greater than the vapor pressure of a liquid within the system. The liquid is being boiled from the system and condensed in the hurling chamber.
4. Temperature limit switch is wired incorrectly.
5. Float switch is improperly adjusted. Remove float switch cover plate and readjust the cam activating the electrical switch.

### THE SYSTEM STARTS AND STOPS RAPIDLY

1. Pumping against a small closed system. Add vacuum storage tank or reset vacuum switches.
2. Closed or partially closed valve in air line.
3. Pipe friction losses in suction line cause higher vacuum close to vacuum producer. Relocate vacuum lines to point which senses true system vacuum.

### BOTH PUMPS RUN

1. Improper vacuum switch adjustment. Readjust lead vacuum switch to make and break at deeper vacuums than the lag switch.

---

## TROUBLESHOOTING PROCEDURES – CONDENSATE PUMP

All units are thoroughly tested at the factory before shipment. They should operate satisfactorily without further adjustment if properly installed and providing they have not been damaged by rough handling in transit. If system or unit performance is not satisfactory, refer to the following check list.

### PUMP WILL NOT START

1. The power supply has been interrupted, disconnect switch is open or selector switch is improperly positioned.
2. Incorrect voltage for motor. Check voltage and wiring with motor characteristics.
3. Incorrect starter coil for power supply.
4. The overload relays in the starter have tripped out and must be reset. Ambient temperature may be too high.
5. Check pump controls or other controls for proper operation.
6. Wiring to control cabinet is incorrect or connections are loose.
7. The strainer is dirty thus retarding flow. Clean periodically.
8. Insufficient condensate has accumulated to actuate float switch.

### PUMP RUNS CONTINUOUSLY

1. Pump is running backward. Rotation of three phase motors may be corrected by interchanging any two of the three wires. Rotation should be clockwise looking down on motor.
2. Steam traps are blowing through causing condensate to return at excessive temperatures. This may reduce the

capacity of pump below its rating, depending on the unit and type of pump furnished. Traps should be repaired or replaced.

3. The total required pressure at the pump discharge is greater than the pressure for which the pump was designed. Check the total pressure which includes atmospheric pressure, the friction head and the static head.
4. A valve in the discharge line is closed or throttled too tightly. Check valve is installed backwards.
5. The impeller eye is clogged.
6. Pump is too small for system.

### CONDENSATE PUMP IS NOISY

1. The pump is working against a lower pressure than designed for. While pump is discharging, adjust plug cock in discharge line until pressure at pump approaches pump rated pressure.
2. Excessive condensate temperature. Correct system conditions. However, this applies to certain units only; others are designed to handle boiling water.
3. Magnetic hum or bearing noise in motor. Consult motor manufacturer's authorized service station nearest unit location.
4. Starter chatters. Trouble is caused by low line voltage, poor connections, defective starter coil, or burned contacts.
5. Pump is running backward.

### SYSTEM IS NOISY

1. Banging in the steam mains is usually caused by “imploding” in condensate lying in low points in lines. These pockets can be eliminated by dripping low points, properly supporting the pipe, or by increasing the pitch of the lines.
2. Improper dripping of the steam mains and risers; where there is a rise in the steam main, or where it branches off into a riser, a drip trap must be installed to the drain line.
3. The piping is too small to drain properly.
4. A defective trap is holding condensate in steam supply line.

### PUMP DOES NOT RETURN ALL CONDENSATE TO BOILER FEED SYSTEM (PUMP FLOODS)

1. Pump is running backward looking down on motor. Rotation of 3 phase motors may be corrected by interchanging any two of the three wires. Pump should run clockwise.
2. Steam traps are blowing through causing condensate to return at excessive temperatures. This may reduce the capacity of pump below its rating, depending on the unit and type of pump furnished. Traps should be repaired or replaced.

3. The total pressure at the pump discharge is greater than the pressure for which the pump was designed. Check the total pressure which includes the boiler pressure, the friction head and the static head.
4. A valve in the discharge line between pump and boiler is closed or throttled too tightly. Check valve is installed backwards.
5. Condensate is held up in system periodically by induced vacuum in boiler or radiation then released in a flood when pump starts. Install equalizer line per piping diagram.
6. The strainer is dirty thus retarding flow. Refer to instructions for cleaning.
7. The impeller eye is clogged with trash.
8. Systems with accumulator tanks should have equalizer line run from accumulator tank to steam header as shown on pages 2 & 3: NOT from accumulator tank to pump receiver NOR from pump receiver to steam header. Install vacuum breaker on accumulator tank, NOT on pump.
9. Pump is too small for the system.

### DEALER SERVICE

If trouble occurs that cannot be rectified, contact your local B&G representative. He will need the following information in order to give you assistance.

1. Complete nameplate data of pump and motor. SEE RATING NAMEPLATE at right.
2. Suction and discharge pipe pressure gauge readings.
3. Ampere draw of the motor.
4. A sketch of the pump hook-up and piping.
5. Provide complete information on boiler control switches and any motorized or solenoid valves in the boiler feed piping.

<b>DOMESTIC® PUMPS</b>		
<b>SERIES</b> <input type="text"/> <b>TM</b>		
<b>MODEL</b> <input type="text"/>		
<b>SERIAL</b> <input type="text"/>		
<b>GPM</b> <input type="text"/>	<b>PSI</b> <input type="text"/>	<b>PUMP</b> <input type="text"/>
<b>CFM</b> <input type="text"/>	<b>IN. HG.</b> <input type="text"/>	<b>PUMP</b> <input type="text"/>
<b>DWGS</b> <input type="text"/>		
<b>POWER V.</b> <input type="text"/>	<b>PH.</b> <input type="text"/>	<b>HZ 60</b> <input type="text"/>
<b>CONTROL V.</b> <input type="text"/>	<b>PH. 1</b> <input type="text"/>	<b>HZ 60</b> <input type="text"/>
<b>TOTAL F.L. AMP.</b> <input type="text"/>	<b>LARGEST MOTOR F.L. AMP.</b> <input type="text"/>	
<b>Bell &amp; Gossett</b> Morton Grove, Illinois 60053		

DN0016



Xylem Inc.  
8200 N. Austin Avenue  
Morton Grove, Illinois 60053  
Phone: (847) 966-3700  
Fax: (847) 965-8379  
www.bellgossett.com