

# Domestic® Pump

## 2' NPSH Horizontal Pumps

### Series HB17™, HB35™, DB™, DB-F™

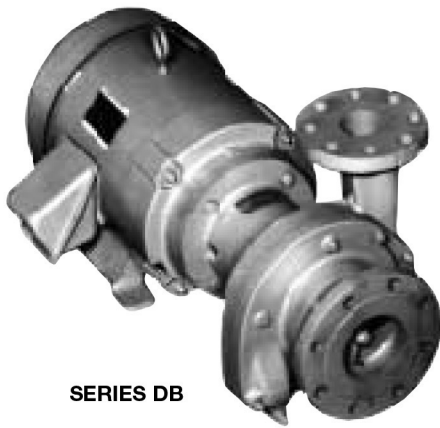

SERIES DB

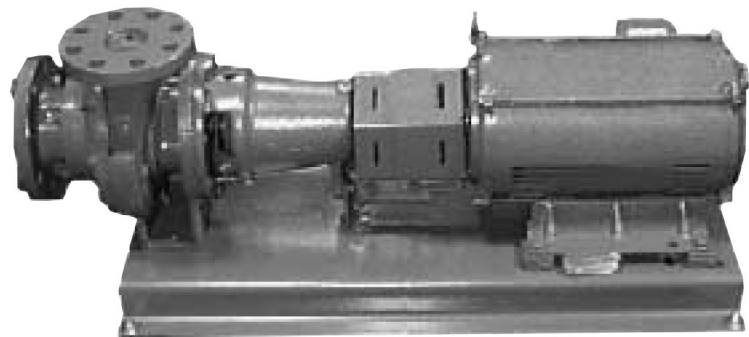

SERIES DBF

**INSTALLER: PLEASE LEAVE THIS MANUAL FOR THE OWNER'S USE.**

### SAFETY INSTRUCTIONS

This safety alert symbol will be used in this manual and on the unit safety instruction decals to draw attention to safety related instructions. When used, the safety alert symbol means ATTENTION! BECOME ALERT! YOUR SAFETY IS INVOLVED! FAILURE TO FOLLOW THESE INSTRUCTIONS MAY RESULT IN A SAFETY HAZARD.

If the decals as noted below are missing or are illegible contact your local B&G representative for a replacement.

1. Electrical connections to be made by qualified Electrician in accordance with all National, State and Local codes.
2. Motor must have properly sized starter with properly sized heaters to provide overload and undervoltage protection.
3. If pump, motor or piping are operating at extremely high or low temperatures, guarding or insulation is required.
4. Operating personnel should be trained in the operation of pumps and associated systems (condensate, boiler feed, etc.).

**WARNING**

ROTATING COMPONENTS DISCONNECT AND LOCK OUT POWER BEFORE SERVICING. DO NOT OPERATE WITHOUT ALL GUARDS IN PLACE. CONSULT INSTALLATION AND SERVICE INSTRUCTION SHEET BEFORE OPERATING OR SERVICING. FAILURE TO FOLLOW INSTRUCTIONS COULD RESULT IN INJURY OR DEATH.

P70642

**WARNING**

EYEBOLTS OR LIFTING LUGS IF PROVIDED ARE FOR LIFTING ONLY THE COMPONENTS TO WHICH THEY ARE ATTACHED. FAILURE TO FOLLOW INSTRUCTIONS COULD RESULT IN INJURY OR DEATH.

P70643

**CAUTION**

DO NOT RUN PUMP DRY. SEAL DAMAGE MAY OCCUR. INSPECT PUMP SEAL REGULARLY FOR LEAKS, REPLACE AS REQUIRED. FOR LUBRICATION REQUIREMENTS, CONSULT SERVICE INSTRUCTIONS. FAILURE TO FOLLOW INSTRUCTIONS COULD RESULT IN INJURY OR PROPERTY DAMAGE.

P70644

Series HB and DB only

**CAUTION**

DO NOT RUN PUMP DRY. SEAL DAMAGE MAY OCCUR. INSPECT PUMP SEAL REGULARLY FOR LEAKS, REPLACE AS REQUIRED. LUBRICATION REQUIREMENTS CONSULT MANUALS. PUMP: POLYUREA-BASED GREASE. FAILURE TO FOLLOW INSTRUCTIONS COULD RESULT IN INJURY OR PROPERTY DAMAGE.

P2002458

Series DB-F only

™		
SERIES	™	
MODEL		
SERIAL		
GPM	PSI	PUMP
CFM	IN HG.	PUMP
DWGS		
POWER V.	PH.	HZ60
CONTROL V.	PH. 1	HZ60
TOTAL F.L. AMP	LARGEST MOTOR F.L. AMP	
Bell & Gossett Morton Grove, Illinois 60053		

DN0016

<b>DOMESTIC® PUMPS</b>	
SERIES	™ GPM
SERIAL	PSI
Bell & Gossett Morton Grove, Illinois 60053	

DN0024

## DESCRIPTION

These horizontal end suction pumps feature a flow inducing propeller and one or two impellers in series. These pumps are supplied with or without mounting base (except for the DB-F which requires a mounting base). All pumps are constructed with mechanical seals intended for high temperature operations.

All models are bronze fitted with replaceable bronze wear rings.

## APPLICATION

The 2' NPSHR rating of these pumps makes them uniquely suited to pumping hot water. With 2 feet of static suction head, the pumps will pump boiling water. Typical applications are on condensate return and boiler feed systems.

These pumps are also well suited for general pumping service of benign liquids.



### WARNING: EXPLOSIBLE

Maximum suction pressure is 35 psi unless otherwise specified by manufacturer. Do not exceed this pressure. Failure to follow these instructions could result in serious injury or death.

## PRELIMINARY INSPECTION

Assure that there is no shipping damage.

Assure that nameplate ratings agree with job specifications and actual conditions.



### CAUTION: NOT A CHEMICAL PUMP

Inject boiler feed compounds from chemical feed tank into boiler feed piping – never into pump suction. Failure to follow these instructions could result in injury or property damage.

## PUMP LOCATION

Locate the pump so there is sufficient room for inspection, maintenance and service. If the use of a hoist or tackle is needed, allow ample head room.



**WARNING:** Eyebolts or lifting lugs if provided are for lifting only the components to which they are attached. If lifting of the entire pump is required, do so with slings placed under the pump assembly as shown. Failure to follow these instructions could result in injury or death.

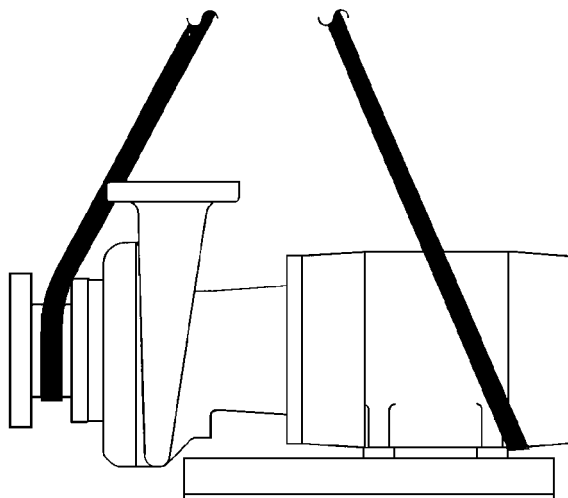

## LOCATION

The best pump location for sound and vibration absorption is on a concrete floor with sub soil underneath. If the pump location is overhead, special precautions should be undertaken to reduce possible sound transmission, consult a sound specialist.

If the pump is not installed on a closed system, it should be placed as near as possible to the source of the liquid supply, and located to permit installation with the fewest number of bends or elbows in the suction pipe.

The installation must be evaluated to determine that the Net Positive Suction Head Available (NPSHA) meets or exceeds the Net Positive Suction Head Required (NPSHR) as stated by the pump performance curve.

## INSTALLATION

This pump is built to provide years of service if installed properly and attached to a suitable foundation. A base of concrete weighing 2<sup>1</sup>/<sub>2</sub> times the weight of the pump is recommended. (Check the shipping ticket for pump weight.)

If possible, tie the concrete pad in with the finished floor. Retain access to pump mounting screws of DB-F pumps.

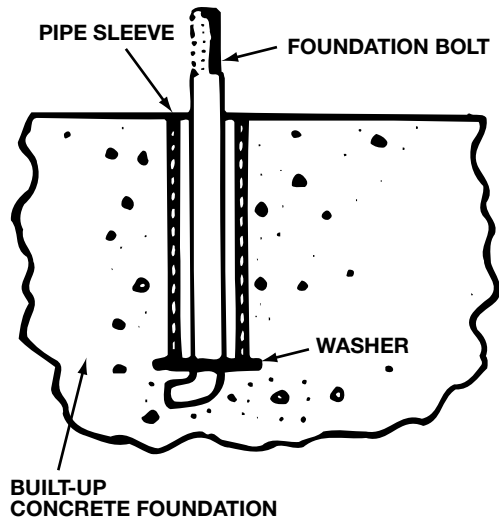

To facilitate easy servicing, some type of expansion fitting should be utilized. The female portion should be inserted into a suitable hole in the floor so that its top surface is flush with the floor surface. Thus, when the hold-down bolts are removed, the motor can be removed by sliding it back from the pump. (See below.)

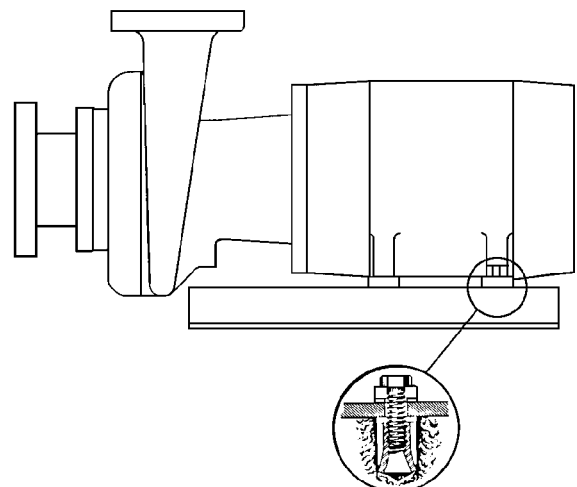

## LEVELING

Place the pump on its concrete foundation supporting it with steel wedges or shims totaling 1" in thickness. These wedges or shims should be put on both sides of each anchor-bolt to provide a means of leveling the base. (See below.)

IT IS VERY IMPORTANT THAT THE PUMP-BASE BE SET LEVEL TO AVOID ANY MECHANICAL DIFFICULTIES WITH THE MOTOR OR PUMP. THIS PUMP WAS PROPERLY ALIGNED (IF FURNISHED WITH A MOTOR) AT THE FACTORY.

HOWEVER, SINCE ALL PUMP BASES ARE FLEXIBLE THEY MAY SPRING AND TWIST DURING SHIPMENT. DON'T PIPE THE PUMP UNTIL IT IS REALIGNED. AFTER PIPING IS COMPLETED AND AFTER THE PUMP IS GROUTED IN AND BOLTED-DOWN, ALIGN IT AGAIN. IT MAY BE NECESSARY TO RE-ADJUST THE ALIGNMENT FROM TIME TO TIME WHILE THE UNIT AND FOUNDATION ARE NEW.

### LEVELING OF PUMP BASE ON CONCRETE FOUNDATION

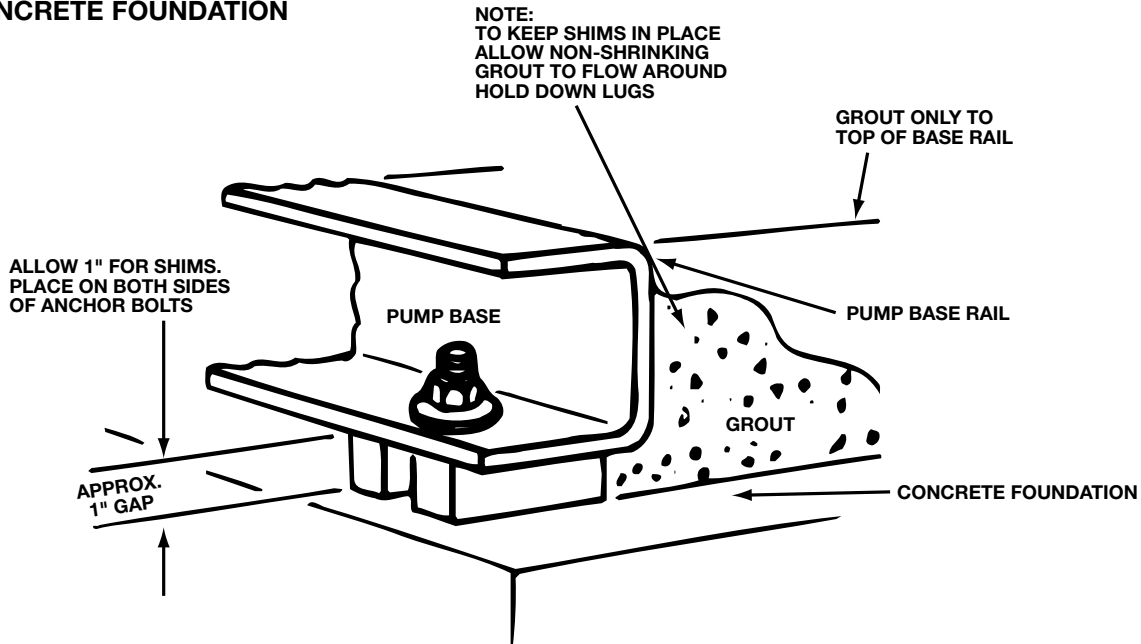

### FLEXIBLE COUPLING ALIGNMENT (SERIES DB-F PUMPS ONLY)

Check parallel alignment by placing a straight edge across the two coupling flanges and measuring the maximum offset at various points around the periphery of the coupling. DO NOT rotate the coupling. If the maximum offset exceeds the .015, realign the coupling.

Check angular alignment with a micrometer or caliper. Measure from the outside of one flange to the outside of the other at intervals around the periphery of the coupling. DO NOT rotate the coupling. The difference between the maximum and minimum must not exceed .056".

If a correction is necessary, be sure to recheck the parallel alignment.

(Note: For maximum life, keep misalignment values as near to zero as possible.)

If the coupling employs the two-piece sleeve with the wire ring, force the ring into its groove in the center of the sleeve. It may be necessary to pry the ring into position with a blunt screwdriver.

All alignment should be done by moving or shimming the motor only. Adjustments in one direction may alter alignment in another. Therefore, check alignment in all directions after a correction is made.

If couplings are to operate at speeds higher than 1800 RPM, greater accuracy of shaft alignment will be required. A dial indicator should then be used.

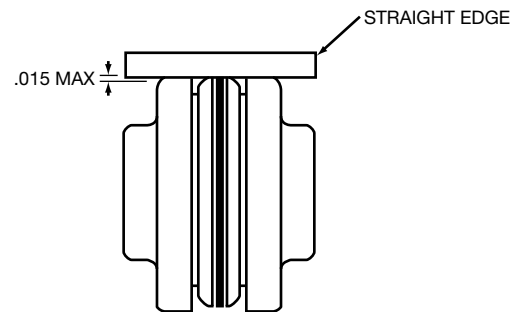

**CHECK PARALLEL ALIGNMENT**

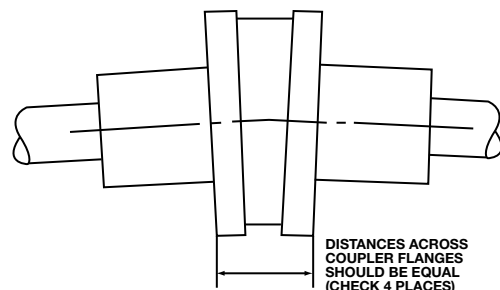

**ANGULAR ALIGNMENT CHECK**

## GROUTING

After the pump has been leveled, securely bolted to the floor, and properly aligned, a good grade of non-shrinking grout

should be poured inside the pump base. To hold wedges or shims in place, allow the grout to flow around them.

## ELECTRICAL WIRING & CONTROLS

Connect power wiring per NEC. Recheck nameplate vs. specifications and conditions. All single phase motors have internal thermal protection.

Three phase motors must use starters with properly sized overload relays. Overload relays furnished are designed for manual reset.



### WARNING: HIGH VOLTAGE ELECTRICITY

Disconnect and lock out power before connecting or servicing unit. Failure to follow these instructions could result in serious injury or death.

## ROTATION

Pump rotation is clockwise when viewed from back of the motor. An arrow is also located on the motor bracket or motor to show the direction of rotation.

As a rule, ordinary wire or band hangers are not adequate to maintain alignment. It is very important to provide a strong, rigid support for the suction and discharge lines.

Where considerable temperature changes are anticipated, fittings for absorbing expansion should be installed in the system in such a way as to avoid strain on the pump.

## PIPING

Always install a section of straight pipe between the suction side of the pump and first elbow. This reduces turbulence of the suction by straightening out the flow of liquid before it enters the pump. The length should be equal to five times the diameter of the pipe. A Bell & Gossett suction diffuser can be used if there is not adequate room for a straight suction line.

A check valve and an isolation/throttling valve should be installed at the discharge of the pump.

Be sure to eliminate any pipe-strain on the pump. Support the suction and discharge pipes independently by use of pipe hangers near the pump. Line up the vertical and horizontal piping so that the bolt-holes in the pump flanges match the bolt-holes in the pipe flanges. **DO NOT ATTEMPT TO SPRING THE SUCTION OR DISCHARGE LINES INTO POSITION.** Bearing wear will result if suction or discharge lines are forced into position. The code for Pressure Piping (A.S.A.B. 31.1) lists many types of supports available for various applications.

### NOTES:

1. When installing the pump, suction and discharge gauge ports should be installed in the pipeline.
2. The pipeline should have isolation valves around the pump and have a drain valve in the suction pipe.
3. When installing the suction and discharge connections to a threaded pump housing the use of PTFE tape sealer or a high quality thread sealant is recommended.

## PUTTING THE UNIT INTO SERVICE

1. Assure that the unit is piped in accordance with instructions.



### WARNING: EXPLOSIBLE

Maximum suction pressure is 35 psi unless otherwise specified by manufacturer. Do not exceed this pressure. Failure to follow these instructions could result in serious injury or death.



### CAUTION: DO NOT REVERSE

Reverse operation can cause extensive damage to pumps. Jog the motor to test for direction of rotation. Failure to follow these instructions could result in serious injury or property damage.

2. Validate that the connected system is ready to operate.
3. Connect electrical supply per National Electrical Code.



### CAUTION: DO NOT RUN DRY. SEAL DAMAGE MAY OCCUR.

Inspect pump seal regularly for leaks. Replace as required. Failure to follow these instructions could result in injury or property damage.

Disconnect and lock out power before connecting or servicing unit. Failure to follow these instructions could result in serious injury or death.

4. Install drain plugs.
5. Prime pump and bleed air from system. Avoid freezing conditions after pump has been primed.
6. Check for proper rotation of all three phase motors. Rotation must be clockwise looking down on the motor as indicated by directional arrow on pump casting. If pump runs backwards, interchange two wires (3 phase only).

8. Bleed all air from the volute. Where appropriate, use an air bleed line to a tank ahead of the pump or to the pump suction.

9. If possible, observe operation thru several cycles.

## OPERATION AND MAINTENANCE

Operators must be familiar with all sections of this manual to understand the operation of the unit.

Hot water, steam and electricity can be hazardous.



**SAFETY INSTRUCTIONS**  
SEE COVER OF THIS MANUAL



**WARNING: EXPLOSIBLE**  
Maximum suction pressure is 35 psi unless otherwise specified by manufacturer. Do not exceed this pressure. Failure to follow these instructions could result in serious injury or death.



**WARNING: HIGH VOLTAGE**  
Disconnect and lock out power before connecting or servicing unit. Failure to follow these instructions could result in serious injury or death.

Check motor nameplate for any lubrication requirements.

### NOTICE/AUTO RESTART

Single phase motors will restart automatically after thermal overload protector trips.

Overload thermal relays in starters must be reset manually.



**CAUTION: SUBSEQUENT DAMAGE**  
A unit showing symptoms of possible problems (overflow, noise, leaks, vibrations, continual operation, etc.) must be corrected immediately. Failure to follow this instruction may result in full liability for subsequent injury or property damage.

Specific maintenance and service instructions follow.

## BEARING MAINTENANCE

### BEARING LUBRICATION SCHEDULE

Type of bearing	First lubrication, assembled pumps and replacement bearing frames	First lubrication, replacement bearings	Lubrication interval, pump, polyurea-based grease, operating hours
Grease-lubricated bearings	Not applicable, lubricated before shipment	Hand pack bearings before pressing on the shaft. After bearing frame assembly, follow relube instructions to lube bearings.	<ul style="list-style-type: none"> <li>• 3600 hours, 2 pole</li> <li>• 7200 hours, 4 pole</li> <li>• 50% for severe conditions: dirty, wet and/or above 100°F (38°C) ambient</li> <li>• 50% for bearing frame temperature above 180°F (82°C)</li> <li>• 75% for lithium-based grease</li> </ul>

## REGREASE THE GREASE-LUBRICATED BEARINGS

It is important to lubricate pumps and motors that require regreasing with the proper grease. See the motor service instructions and nameplate for motor regreasing information. Pumps are to be regreased using the grease types listed below or approved equal. Always keep pump and motor properly lubricated.

### NOTICE:

Make sure the grease container, the greasing device, and the fittings are clean. Failure to do so can result in impurities entering the bearing housing when you regrease the bearings.

1. With fully enclosed coupling guards, regrease pump while pump is running.
  - a. With old style open ended guards, stop pump, re-grease, and hand turn shaft before re-starting.
2. Wipe dirt from the grease fittings before greasing.
3. Fill both of the grease cavities through the fittings with the recommended grease. Stop when grease leaks out at shaft.
4. If needed, stop pump and wipe off excess grease.
5. Restart pump.

The bearing temperature usually rises after you regrease due to excess supply of grease. Temperatures return to normal in about two to four operating hours as the pump runs and purges the excess grease from the bearings. Maximum normal bearing housing temperature for polyurea-based grease is 225°F (107°C) and for lithium-based grease 180°F (82°C).

## LUBRICATING GREASE REQUIREMENTS

### NOTICE:

- Never mix grease of different consistencies (NLGI 1 or 3 with NLGI 2) or with different thickeners. For example, never mix lithium-based grease with a polyurea-based grease. This can result in decreased performance.
- Remove the bearings and old grease if you need to change the grease type or consistency. Failure to do so can result in equipment damage or decreased performance.

**SPECIFICATIONS – GREASE TYPES**

Polyurea-based greases	Lithium-based greases, NLGI 2
Pumps built <b>on or after Dec 1, 2014</b> use Polyurea-based greases. See <b>date code label</b> and <b>lubrication label</b> on pump or bearing frame <b>indicating polyurea-base grease</b>	Pumps built <b>before Dec 1, 2014</b> were built with Lithium-based greases, NLGI 2, and do <b>not</b> have lubrication label on pump or bearing frame indicating pump grease type
ExxonMobil Polyrex™ EM	Shell Gadus® S2 V100 2 (was Alvania® RL 2)
Chevron SRI NLGI 2	Chevron Multifak® EP 2
Shell Gadus® S5 T100 2	ExxonMobil Unirex™ N2

**GENERAL INSTRUCTIONS**

1. Keep this pump and motor properly lubricated.
2. When there is a danger of freezing, drain the pump.
3. Inspect pump regularly for leaky seals or gaskets and loose or damaged components. Replace or repair as required.

**SEAL REVISION**

As of June 1997, DB and DB-F pumps use a Type 2 seal. This seal is interchangeable with pumps that pre-date this cut-off date. Regardless of date of manufacture of the pump, when installing the Type 2 seal, the retaining ring is oriented with the large OD facing the seal. (See illustration.)

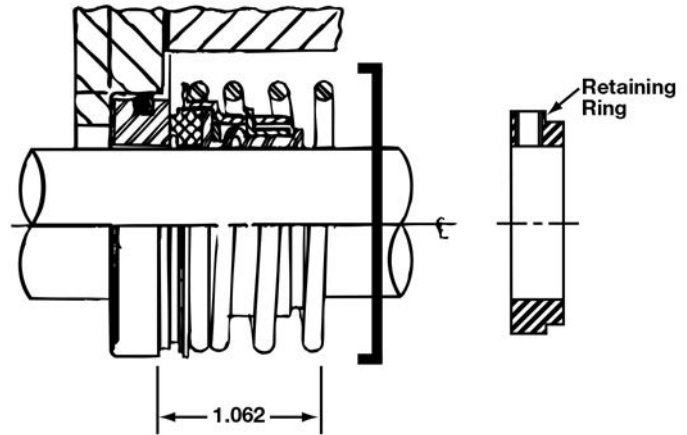

**PUMP SERVICE INSTRUCTIONS FOR SERIES DB AND DB-F PUMP ENDS**

1. Close pump isolation valve or system return line valve. Operate pump momentarily to discharge as much water as possible. Close pump discharge valve.

**CAUTION: HOT SURFACES**  
Surfaces may be hot when system is in operation. Do not touch exposed components, let unit cool before servicing. Failure to follow these instructions could result in serious injury or death.

2. Shut-off and lock out power.

**WARNING: HIGH VOLTAGE**  
Disconnect and lock out power before connecting or servicing unit. Failure to follow these instructions could result in serious injury or death.

3. Make sure unit is cool enough that pump can be handled safely. Open drain to remove remaining liquid.

4. Carefully remove pump drain plug and air relief tube. Wait for complete drainage.
5. Loosen both the discharge connection and the suction housing to pump volute fasteners. Assure that pressure is relieved per caution note.

**CAUTION: PRESSURIZED SYSTEM**  
Operating system may contain very hot water under pressure. Close inlet and open drains before servicing. When servicing, *loosen* screws and move components to assure pressure is relieved before *removing* screws. Keep drains open during servicing. Failure to follow these instructions could result in injury or property damage.

## PUMP SERVICE INSTRUCTIONS FOR SERIES DB AND DB-F PUMP ENDS cont.'d

6. Remove discharge connection and suction connection. Unbolt motor and or pump from base. Place assembly on workbench.
7. Remove suction housing and then axial flow impeller, shaft, and straightening vanes in the following manner: Remove axial flow impeller set screws. Remove the axial flow impeller, remove the straightening vanes, and unscrew the shaft extension.
8. Remove cap screws holding pump volute and motor bracket together. Remove volute by lifting straight away from motor and bracket assembly.
9. Remove first centrifugal impeller by inserting two pry bars between motor bracket and impeller on opposite sides of impeller, being careful to pry equally, and ONLY WHERE THE SHROUD OR THE IMPELLER IS SUPPORTED BY A VANE. Lift off the diaphragm plate and wearing rings as an assembly. Remove second centrifugal impeller, using a puller. The machined groove on the impeller hub is for this purpose.
10. To install new seal proceed as follows:
  - (1) Thoroughly clean recess in head. Moisten or soap the "rubber" portion of seal. Press rubber and ceramic into recess firmly by hand making certain both parts bottom evenly. If seat cannot be bottomed with fingers place the cardboard shipping disc on seat and force into place with flat tool. Wipe clean with soft clean cloth to remove dirt or excess soap.
  - (2) Carefully place head into position on motor shaft without displacing ceramic seat, and secure bracket to motor with cap screws.
  - (3) Place motor vertically with pump end up. Do not attempt reassembly of pump with the shaft horizontal.
  - (4) The "carbon" of the rotating part of the seal should not be loose. If it is, hold in place with grease. Using a clean, lint-free cloth, wipe mating surfaces, perfectly clean. Soap the shaft and push seal onto shaft so that it touches the carbide seat.
  - (5) Replace seal collar as close as possible to original position, and tighten the set screw.
11. Replace second impeller on shaft, being careful to bottom it on shaft shoulder. Replace diaphragm plate with its wearing rings, and replace first impeller. Reassemble pump volute to bracket.
12. Reassemble propeller. Tighten thoroughly.
13. Reassemble straightening vanes, being careful to locate properly on pin. Reassemble axial flow impeller and tighten the set screws holding it to the propeller stem. Reassemble suction housing using new gasket.
14. Reposition the pump in place, and bolt down. Reconnect discharge and suction.
15. Reconnect air relief tubing and motor wiring.
 

**NOTE:** See page 4 for additional DB-F instructions (Coupler Alignment).

**CAUTION: DO NOT RUN DRY. SEAL DAMAGE MAY OCCUR.**

Inspect pump seal regularly for leaks. Replace as required. Failure to follow these instructions could result in injury or property damage.

16. Close drain and slowly open inlet gate valves.

**WARNING: EXPLOSIBLE**

Do not pressurize receiver. Do not plug overflow. Pipe vent opening to atmosphere. Do not restrict. Open valves slowly. Failure to follow these instructions could result in serious injury or death.

17. Three phase motors should be started momentarily to check rotation. If pump runs backward, interchange any two motor leads. (Any electrical service should be performed by a qualified electrician).

**CAUTION: DO NOT REVERSE**

Reverse operation can cause extensive damage to pumps. Jog the motor to test for direction of rotation. Failure to follow these instructions could result in serious injury or property damage.

18. Observe operation thru several cycles.

### 2DPB03 SERIES DB CROSS SECTION

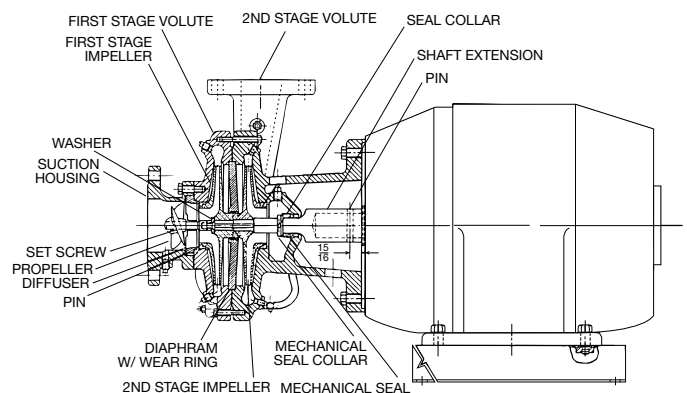

## PUMP SERVICE INSTRUCTIONS FOR SERIES HB17 AND HB35 PUMPS

1. Close pump isolation valve or system return line valve. Operate pump momentarily to discharge as much water as possible. Close pump discharge valve.
2. Shut-off and lock out power.

**CAUTION: HOT SURFACES**

Surfaces may be hot when system is in operation. Do not touch exposed components, let unit cool before servicing. Failure to follow these instructions could result in serious injury or death.

**WARNING: HIGH VOLTAGE**

Disconnect and lock out power before connecting or servicing unit. Failure to follow these instructions could result in serious injury or death.

3. Make sure unit is cool enough that pump can be handled safely. Open drain to remove remaining liquid.

## PUMP SERVICE INSTRUCTIONS FOR SERIES HB17 AND HB35 PUMPS cont.'d

4. Carefully remove pump drain plug and air relief tube. Wait for complete drainage.
5. Loosen both the discharge connection and the suction housing to pump volute fasteners. Assure that pressure is relieved per caution note.



### CAUTION: PRESSURIZED SYSTEM

Operating system may contain very hot water under pressure. Close inlet and open drains before servicing. When servicing, *loosen* screws and move components to assure pressure is relieved before *removing* screws. Keep drains open during servicing. Failure to follow these instructions could result in injury or property damage.

6. Complete the removal of the above hardware. Remove pump/motor assembly and place on work bench.
- 7a. Remove the suction housing capscrews and separate the pump/motor assembly from the suction housing. Note, the diffuser should separate from the suction housing to allow the pump/motor assembly to be removed.
- 7b. Remove propeller, propeller stem and diffuser from the assembly as follows: Keyed Motor Shafts (5HP and larger). Remove propeller set screws. Remove propeller, remove diffuser, and unscrew the propeller stem.
8. Remove capscrews holding motor bracket and pump volute together. Remove motor and bracket assembly from volute by lifting straight away from volute.
9. To remove impeller from the motor shaft proceed as follows: Keyed Shafts. Remove impeller with gear puller or other means which will not damage impeller or bend motor shaft.
10. Remove rotating part of seal from shaft, being careful not to break carbon face.
11. Remove capscrews holding motor bracket to motor and remove bracket.
12. Remove stationary part of seal assembly, being careful not to chip or break ceramic seal.
13. To install seal proceed as follows:
  - (1) Clean recess in bracket thoroughly. Coat recess and "rubber" portion of seat with soap solution. Press seat into recess firmly by hand making certain both parts bottom evenly. If seat cannot be bottomed with fingers place cardboard shipping disc on ceramic and force into place with flat tool.
  - (2) Carefully place bracket into position on motor shaft without displacing ceramic seat and secure bracket to motor with capscrews.
  - (3) Place motor vertically with pump end up. Do not attempt assembly of seal and impeller with shaft horizontal.
  - (4) The "carbon" of rotating part of seal should not be loose. If it is, hold in place with grease. Using clean, lint free cloth, wipe mating surfaces perfectly clean. Soap shaft and push seal onto shaft so that carbon will contact ceramic seal. If spacer is required, use grease to cause spacer to adhere to bottom of seal after seal has been put on shaft. Be sure spacer is on larger diameter of shaft so that it will not catch between shoulder and impeller.
14. Place impeller on shaft. Make sure impeller is seated.
15. Reassemble volute to bracket.

### SERIES HB17 CROSS SECTION

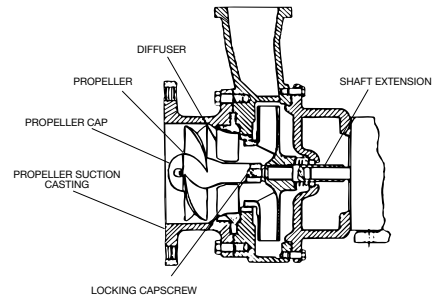

### SERIES HB-35 CROSS SECTION

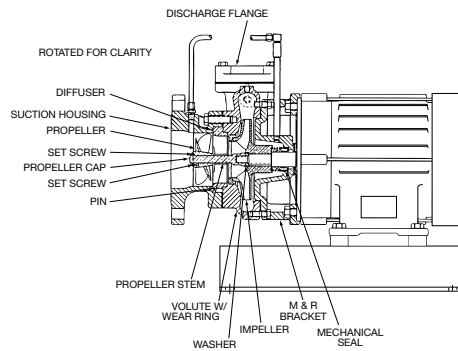

16. Install stem over drive pin in impeller eye. Tighten lock nut.
17. Set stem to .004 TIR.
18. Install diffuser.
19. Install propeller and tighten set screws.
- 19a. Install propeller cap and tighten set screws.
20. Using new gasket and noting alignment pin, install assembly on suction housing.
21. Install suction housing and discharge fasteners and tighten.
22. Reconnect pump bleed line and motor wiring.



### CAUTION: DO NOT RUN DRY. SEAL DAMAGE MAY OCCUR.

Inspect pump seal regularly for leaks. Replace as required. Failure to follow these instructions could result in injury or property damage.

23. Close drain and slowly open inlet valves.



### WARNING: EXPLOSIBLE

Do not pressurize receiver. Do not plug overflow. Pipe vent opening to atmosphere. Do not restrict. Open valves slowly. Failure to follow these instructions could result in serious injury or death.

24. Jog to check motor rotation.



### CAUTION: DO NOT REVERSE

Reverse operation can cause extensive damage to pumps. Jog the motor to test for direction of rotation. Failure to follow these instructions could result in serious injury or property damage.

25. Observe operation thru several cycles.

## TROUBLE SHOOTING

### PUMP WILL NOT START

1. Power supply has been interrupted, disconnect switch is open or control switch is improperly positioned.
2. Incorrect voltage for motor. Check voltage and wiring with motor characteristics.
3. Incorrect starter coil for power supply.
4. Overload relays in starter have tripped out and must be reset. Ambient temperature may be too high.
5. Wiring to control is incorrect or connections are loose.
6. Control signals are for pump to be "off".

### PUMP CAPACITY IS REDUCED

1. Pump is running backward. Rotation should be clockwise looking down on motor toward pump. Rotation of 3 phase motors may be corrected by interchanging any two of the three wires. (Any electrical service should be performed by a qualified electrician.)
2. Total pressure at pump discharge is greater than that for which the pump was designed. Check pressure requirement which includes system back pressure, friction and static head.
3. Excessive suction lift or incorrect piping.
4. A valve in pump discharge line or suction line is closed or throttled too tightly. Check valve is installed backwards.
5. Impeller eye is clogged with debris.

6. Pump is too small for system.
7. A strainer is dirty thus retarding flow.
8. Pump has lost its prime. Release trapped air in pump and reprime.
9. Steam traps are blowing through causing condensate to return at excessive temperatures. This may reduce the capacity of pump below its rating, depending on the unit and type of pump furnished. Traps should be repaired or replaced.

### PUMP MAKES NOISE

1. Pump is running backward.
2. Install square-headed plug cock in discharge line and throttle until operating pressure at pump approaches pump rated pressure. Secure adjustment of plug cock by tightening lock nut.
3. Magnetic hum or bearing noise in motor. Consult motor manufacturer's authorized service station.
4. Starter chatters. Trouble is caused by low line voltage, poor connections, defective starter coil, or burned contacts.
5. Excessive temperature. Correct system conditions.
6. Entrained air. Release trapped air.

## DEALER SERVICING

If trouble occurs that cannot be rectified, contact your local B&G representative. He will need the following information in order to give you assistance.

1. Complete nameplate data of pump and motor. SEE RATING NAMEPLATE.
2. Suction and discharge pipe pressure gauge readings.
3. Ampere draw of the motor.
4. A sketch of the pump hook-up and piping.

<b>DOMESTIC® PUMP</b>	
SERIES <sup>TM</sup>	GPM
SERIAL	PSI
DN0024	<b>Bell &amp; Gossett</b> Morton Grove, Illinois 60053

**xylem**  
Let's Solve Water

Xylem Inc.  
8200 N. Austin Avenue  
Morton Grove, Illinois 60053  
Phone: (847) 966-3700  
Fax: (847) 965-8379  
www.bellgossett.com

Bell & Gossett is a trademark of Xylem Inc. or one of its subsidiaries.  
© 2014 Xylem Inc. DN0141E November 2014