

# Isolation Flange

## Operational Limits

Max Temperature	200°F (93°C)
Max Pressure	150psig (10 Bar)

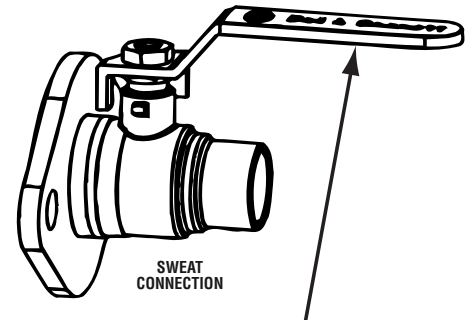

**WARNING LABEL PART NO. V56873  
INSTALLED IN THIS LOCATION.  
IF MISSING, IT MUST BE REPLACED.**

**INSTALLER: PLEASE LEAVE THIS MANUAL FOR THE OWNER'S USE.**



**WARNING:** Wetted surface contains not more than 0.25% of lead by weight.



**WARNING:** This product can expose you to chemicals including Lead, which is known to the State of California to cause cancer and birth defects or other reproductive harm. For more information go to: [www.P65Warnings.ca.gov](http://www.P65Warnings.ca.gov).



## SAFETY INSTRUCTION

This safety alert symbol will be used in this manual to draw attention to safety related instructions. When used, the safety alert symbol means **ATTENTION! BECOME ALERT! YOUR SAFETY IS INVOLVED! FAILURE TO FOLLOW THESE INSTRUCTIONS MAY RESULT IN A SAFETY HAZARD.**

## DESCRIPTION

The Isolation Flange (IF) is a combination of an isolation valve and a companion flange for circulators. The isolation flange allows easy service or replacement of the circulator without the need to drain the system.

## INSTALLATION INSTRUCTIONS

1. Install one IF on the suction side of the hydronic circulator and one on the discharge side.
2. See the following installation instructions and drawings for additional information.



**WARNING:** System fluids under temperature or pressure can be hazardous. Be sure the pressure is relieved and system temperature is below 100°F (38°C). Failure to follow these instructions could result in property damage and/or personal injury.

3. Apply torque in even increments to both flange bolts. Refer to the pump manufacturers instruction manual for torque value. Both the suction and discharge flanges must be torqued in this manner.



**WARNING:** To prevent leakage, make certain that the flange bolts have been adequately torqued. Failure to follow these instructions could result in personal injury and/or property damage.

### For NPT connections:

- a) Apply pipe compound conservatively to the male connecting fittings only.
- b) Upon completion of IF installation to piping, check connections for leaks.



**CAUTION:** Over-tightening and breakage can occur with the use of teflon pipe joint compounds. Teflon provides lubricity so that care must be exercised not to over-tighten joints. Failure to follow these instructions could result in property damage and/or personal injury.

### For Sweat Connections:

- a) For soldering, use 95-5 (Tin-Antimony) solder and a good grade of flux. Solder end valves are suitable for soldering without disassembly. Refer to table 1 for solder types and temperatures. Solder joint strength and working pressure varies with tube size, solder grade and temperature as defined in ASME B16.18 and B16.22. Do not exceed the limits stated in table 1.
- b) Cut the tube square and deburr both ID and OD. Do not deform the tube, otherwise it must be re-sized. Clean tube end and valve solder cup with abrasive cloth or wire brush until the surfaces are bright metal. Alternatively use an approved cleaning paste: in this case spread the paste evenly on the tube; insert the tube into the cup and turn to distribute the paste; finally remove the excess paste.
- c) When sweating joints, first wrap the valve body with a cool wet rag, then direct the flame with care to avoid subjecting the valve to excessive heat. Allow the valve to cool before touching or operating. The valve must be in the fully closed position during soldering. Valve seats may be damaged if soldering is done in the open or partly open position.

- d) While soldering, it is important to use a properly sized torch with a sharp pointed flame so that the solder end is heated fully and quickly. Apply heat so that the flame is directed on the cup area but away from the valve body. Although soft 50/50 solder is easier to use, these valves can also be successfully soldered with 95-5, however caution must be used to prevent damage (see table 1.) Cool the valve body before soldering the second end.
- e) Check the soldered connections for leaks.

**CAUTION:** Heat associated with the use of silver solder may damage valve and void the warranty. Do not use silver solder. Failure to follow these instructions could result in property damage and/or moderate personal injury.

**IMPORTANT:** Relieve pressure from the circulator by slowly loosening the bolts allowing the water to slowly drain from the pump body. Refer to the circulator instruction manual when reinstalling a circulator. After a pump is installed, turn the handle of both isolation valves counter-clockwise 90° to open the valves for normal operation.

### SERVICE INSTRUCTION

There is no service required for the Isolation flange.

**CAUTION:** Corrosion or leakage of the IF valve can cause damage or injury. Periodically inspect the IF valve for signs of leakage or corrosion. If corrosion or leakage is noted, the IF valve must be replaced. Failure to follow these instructions could result in property damage and/or moderate personal injury.

### OPERATING INSTRUCTIONS

To isolate the circulator from the system, turn the handle of both isolation valves clockwise 90° to close the valve. Remove circulator for repair/replacement.

TABLE 1										
Pressure – Temperature Ratings										
Joining Material	Melting Range Degrees		Working Temperature Degrees		Maximum Working Gauge Pressure					
	°F	°C	°F	°C	Size ½" – 1"		Size 1¼" – 2"		Size 2½" – 4"	
					psi	kPa	psi	kPa	psi	kPa
95-tin-antimony solder ASTM B32 alloy grade 95TA	450/464	230/240	0/+100	-18/+38	500*	3500*	400*	2800*	300*	2100*
			0/+150	-18/+66	400*	2800*	350*	2400*	275*	2000*
			0/+200	-18/+93	300*	2100*	250*	1700*	200	1400
			0/+250	-18/+121	200	1400	175	1200	150	1050

Note: Above stated limits are not imposed by the valve, but by the strength of the soldering joint according to ASME B16.22.  
\*Soldered copper tube joints have been tested at 230 psi (1600 kPa) in accordance with ISO 2016.

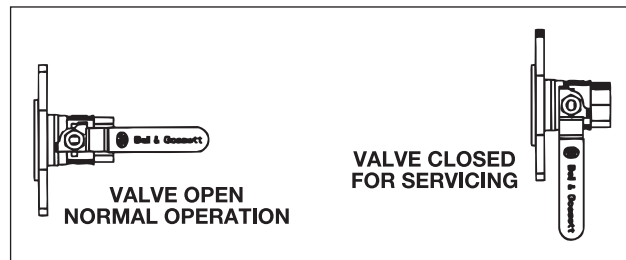
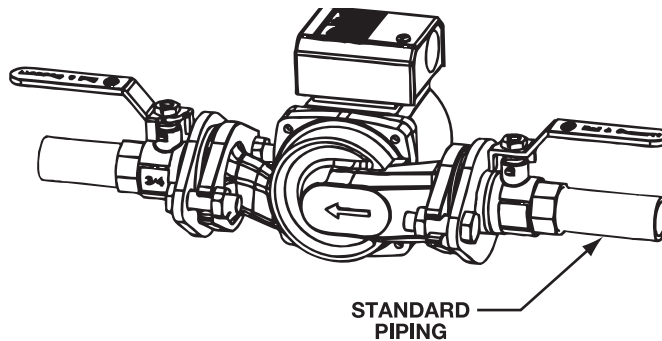

Xylem Inc.  
8200 N. Austin Avenue  
Morton Grove, Illinois 60053  
Phone: (847) 966-3700  
Fax: (847) 965-8379  
www.xylem.com/bellgossett