



**McDonnell & Miller**  
a xylem brand

**INSTRUCTION MANUAL**

MM-284J



**Series PSE-800  
Probe Type Low Water Cut-Off  
for Steam Boilers**

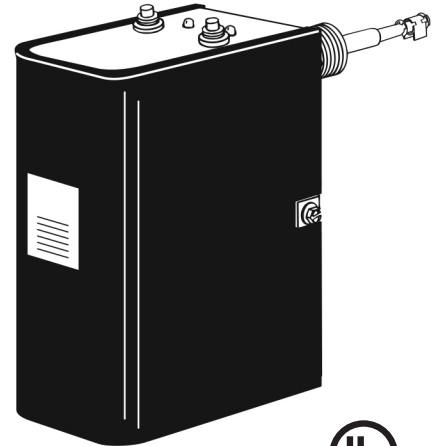

**Applications:**  
Residential and Commercial

**WARNING**

	<ul style="list-style-type: none"> <li>• Before using this product read and understand instructions.</li> <li>• Save these instructions for future reference.</li> <li>• All work must be performed by qualified personnel trained in the proper application, installation, and maintenance of plumbing, steam, and electrical and/or systems in accordance with all applicable codes and ordinances.</li> </ul>
	<ul style="list-style-type: none"> <li>• To prevent flooding, do not use manual reset models with electric automatic water feeders.</li> <li>• Boiler water pH levels above 10.0 may interfere with proper operation of the low water cut-off. Levels above 10.0 must be corrected in order to ensure proper operation of the low water cut-off. Failure to follow this warning may result in property damage, personal injury or death.</li> <li>• To prevent electrical shock, turn off the electrical power before making electrical connections.</li> <li>• This low water cut-off must be installed in series with all other limit and operating controls installed on the boiler. After installation, check for proper operation of all of the limit and operating controls, before leaving the site.</li> </ul>
	<ul style="list-style-type: none"> <li>• We recommend that secondary (redundant) Low Water Cut-Off controls be installed on all steam boilers with heat input greater than 400,000 BTU/hour or operating above 15 psi of steam pressure. At least two controls should be connected in series with the burner control circuit to provide safety redundancy protection should the boiler experience a low water condition. Moreover, at each annual outage, the low water cut-offs should be dismantled, inspected, cleaned, and checked for proper calibration and performance.</li> </ul>
	<ul style="list-style-type: none"> <li>• When installing jumper wire make sure you are not introducing a second voltage source into the burner circuit and thereby bypassing other safety, limit, and operating controls.</li> <li>• This product can expose you to chemicals including Lead, which is known to the State of California to cause cancer and birth defects or other reproductive harm. For more information go to: <a href="http://www.P65Warnings.ca.gov">www.P65Warnings.ca.gov</a>.</li> <li>• Previous controls should never be installed on a new system. Always install new controls on a new boiler or system.</li> </ul>
	<p>Failure to follow this warning could cause property damage, personal injury or death.</p> <p><b>CAUTION:</b></p> <ul style="list-style-type: none"> <li>• A more frequent replacement interval may be necessary based on the condition of the unit at time of inspection. McDonnell &amp; Miller's warranty is one (1) year from date of installation or two (2) years from the date of manufacture.</li> </ul>

## Operation

The Series PSE-800 probe type LWCO's provide protection against low water conditions for residential and commercial steam boiler applications. The control uses patented technology to monitor changes in water conductivity. When defined parameters are exceeded, the new PSE-800 makes a decision to shut the burner off based on the volatility/variability

of the resistance readings. This new patented technology provides the best protection possible without turning off the boiler unless a low water condition exists. As an added measure of safety, the control will turn off the boiler if it recognizes an out-of-water condition when the sensitivity threshold is exceeded.

## SPECIFICATIONS

Automatic reset after power outage

All models include a provision for adding an alarm or automatic water feeder.

30 second Delay on Make (DOM)

10 second Delay on Break (DOB)

### Control Unit

#### Temperature Ratings:

Temperature:

Storage: -40°F to 135°F (-40°C to 57°C)

Ambient: 32°F to 120°F (0°C to 49°C)

Humidity: 85% (non-condensing)

### Probe Specifications

Maximum Steam Pressure: 15 psi (1.0 kg/cm<sup>2</sup>)

Probe Sensitivity: 7,000 ohm

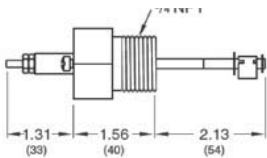
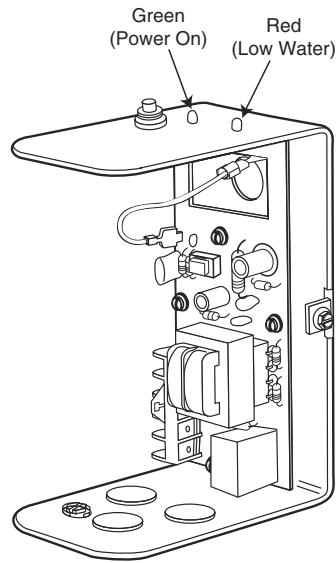

Standard Probe

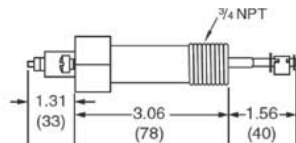

'U' Probe

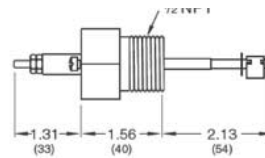

'RX2' Probe

Model	Control Voltage	Motor Switch Rating	Pilot Rating
PSE-802-24 PSE-802-U-24 PSE-802-RX2-24	24 VAC	N/A	50VA
PSE-801-120 PSE-801-U-120	120 VAC	7.5 FLA 43.2 LRA	125VA

HZ: 50/60

Control Power Consumption:

1.7VA @ 24VAC

3.6VA @ 120VAC

Electrical Enclosure Rating: NEMA 1 General Purpose

# INSTALLATION

## TOOLS NEEDED:

One (1) flathead screwdriver, and one (1) pipe wrench.  
For Remote Installations a level and power drill will be required.

## STEP 1 - Locating and Installing the Probe

a. Based on the following criteria locate a suitable position for the probe:

### For all Applications:

1. Refer to boiler manufacturers instructions to determine suitable tapping for the probe.
2. Make sure probe is installed above minimum safe water line as determined by the boiler manufacturer.
3. Make sure that ends and sides of the probe are at least 1/4" (6.4mm) from all internal metal surfaces.
4. Make sure the probe is positioned to shut off the boiler before the water level falls below the lowest visible part of the gauge glass.

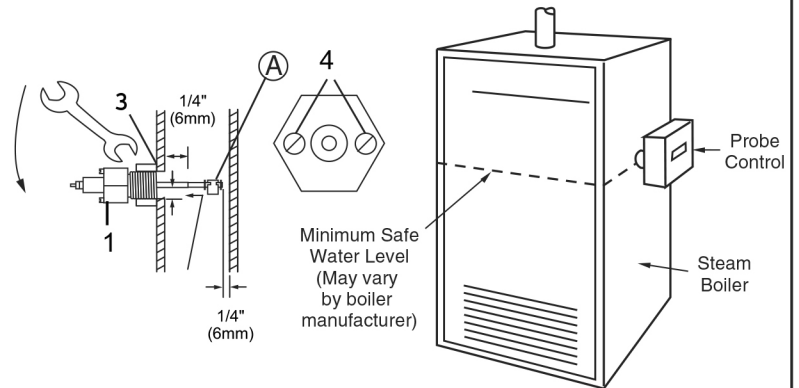

b. Sparingly, apply pipe sealant to the external threads (D) of the probe (A).

### **WARNING**

**Do not use PTFE tape. Only use pipe sealant.**  
**Failure to follow these instructions will cause the probe not to function as intended and could cause property damage, personal injury or death.**

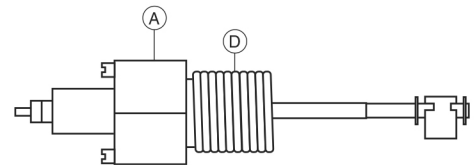

c. Using a wrench, tighten the probe (A) into the tapped connection (E) that was determined in Step 1 of these instructions. Tighten to 47 ft•lb (64 N•m).  
NOTE: Be sure to align the probe so that the mounting screws (F) are in a horizontal position.

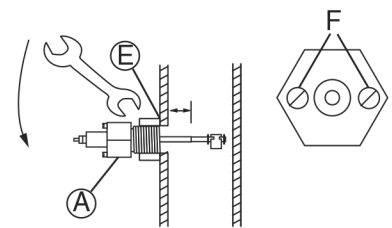

## STEP 2 - Installing Control Box

a. Using a flathead screwdriver, loosen the two (2) screws that secure the cover (G) to the control about 1-1/2 turns and remove cover.

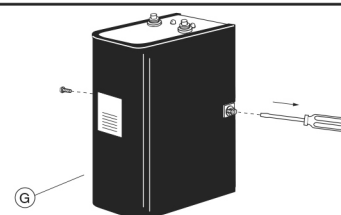

## STEP 2 - Installing Control Box (continued)

### Direct Mounting

- b. Using a flathead screwdriver, loosen the probe mounting screws (F) 1/8" (3mm) about 1-1/2 turns and slip the control housing (G) over these two screws at a 20° angle.

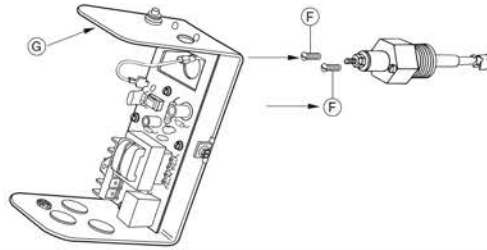

- c. Rotate the control housing (G) 20° counter-clockwise so that the slots in the control base are firmly under the screw heads. Tighten the mounting screws (F) to approximately 2 ft•lb (2.6 N•m).

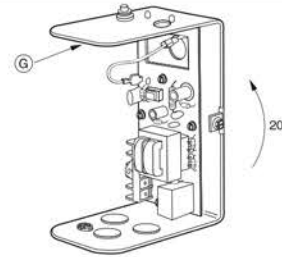

### Remote Mounting

- d. Identify a desirable location to mount the control assembly (G) and comply with the following steps:

1. Using a level, draw a horizontal line at the location and mark two positions 1-1/4" (31.75 mm) apart on the horizontal line.
2. Drill a 0.113 dia. hole 1/2" (13 mm) deep in each position on the horizontal line.
3. Insert the two (2) sheet metal screws (provided) into the two holes. Using a flathead screwdriver, tighten the screws so that the base of the screw head is 1/8" from the mounting surface.  
\* Repeat Steps 2b. and 2c. above.

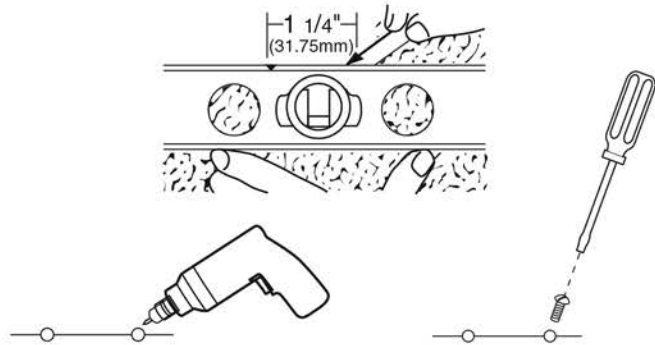

## STEP 3 - Probe Wiring

### Direct Mounted Probe

- a. Slip the ring terminal lead (J) followed by the lock-washer (K) over the threaded end of the probe (A). Tighten the wing nut (L) onto the probe to approximately 1/2 ft•lb (.65 N•m).

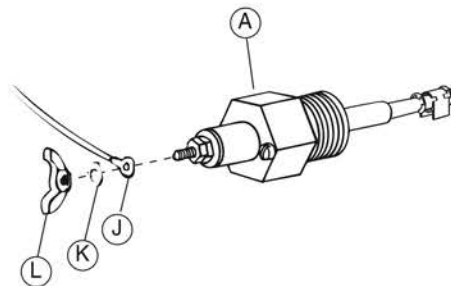

- b. Connect the probe (A) to the wiring circuit by sliding the female quick-connect terminal of the probe wire onto the male spade terminal J1 probe (terminal may be marked J7 on older units).

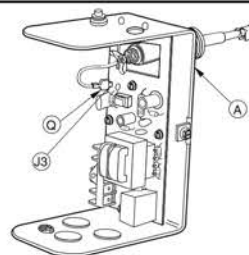

## Remote Mounted Probe

c. Connect the probe (A) to the wiring circuit by:

1. Connecting a suitable 16 AWG wire (not provided) to the threaded end (V) of the probe (A).
2. Place the lockwasher (K) and wing nut (L) (provided) over the threaded end of the probe and tighten the wing nut to 1/2 ft•lb (.65 N•m).
3. Using a flathead screwdriver, attach a suitable green 16 AWG wire (not provided) to the green ground screw (X) at the base of the probe.
4. Route the two wires through a protected wire way to the control unit (G) through the conduit knock-outs in the base of the control.
5. Using the female quick-connect terminal (QQ) provided, connect the wire, from step 1, to the male spade terminal marked "PROBE" (J1). On older units, use the "P" terminal block or (J2) terminal spade connection.
6. Using a flathead screwdriver, connect the green wire, from Step 3, to the green ground screw (W) on the housing of the control.

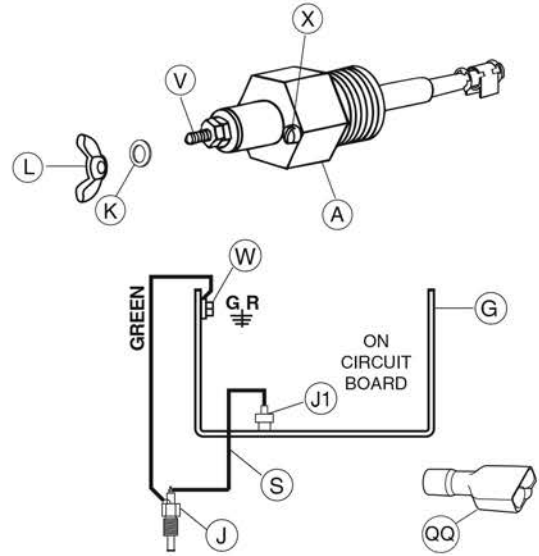

## STEP 4 - Control Wiring

### ⚠ WARNING



- To prevent electrical shock, turn off the electrical power before making electrical connections.
  - This low water cut-off must be installed in series with all other limit and operating controls installed on the boiler. After installation, check for proper operation of all of the limit and operating controls, before leaving the site.
  - All work must be performed by qualified personnel trained in the proper application, installation, and maintenance of plumbing, steam, and electrical equipment and/or systems in accordance with all applicable codes and ordinances.
- Failure to follow this warning could cause electrical shock, an explosion and/or fire, which could result in property damage, personal injury or death.

a. Turn off all power to boiler and boiler controls.

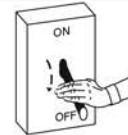

b. Electrical Conduit Connection

- Connect electric conduit using knockouts provided.
- Follow accepted electrical practices when installing fittings and making connections.
- Refer to and follow local codes and standards when selecting the types of electrical fittings and conduit.

### ⚠ CAUTION

Do not use "manual reset" models with electric automatic water feeders.  
Failure to follow this caution can cause flooding and property damage.

### ⚠ IMPORTANT

Boiler manufacturer schematics should always be followed. In the event that the boiler manufacturer's schematic does not exist, or is not available from the boiler manufacturer, refer to the schematics provided in this document.

### ⚠ WARNING



To prevent an electrical fire or equipment damage, electrical wiring must have a rating of 167°F (75°C) if the liquid's temperature exceeds 180°F (82°C).  
Failure to follow this warning could cause property damage, personal injury or death.

## Wiring Diagram Legends

1. Bold lines indicate action to be taken in Step shown.
2. Dotted black lines indicate internal wiring.

## STEP 4 - Control Wiring (continued)

- d. For all wire connections to the terminal block (M).
- 1.Strip about 1/3" (8.5 mm) of insulation from the wire.
  - 2.Loosen the terminal screw (N) but DO NOT REMOVE. Move the wire clamping plate (P) back until the plate touches the back side of the screw head.
  - 3.Insert the stripped end of the wire under the wire clamping plate (P) and securely tighten the terminal screw (N).

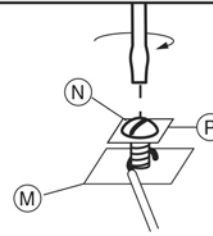

## PSE-802 using Harness Connection

Connect plug (A) of wiring harness to receptacle (B).

### NOTE

Wiring harness is provided by boiler manufacturer.



### CAUTION

Do not use force to insert plug. This may damage receptacle solder connections.

Check to make sure factory supplied jumper is installed between terminals (H) and (C).

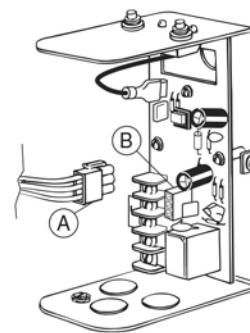

## PSE-802 using Terminal Connections

- Connect neutral wire (A) of 24 volt circuit to terminal (N).
- Connect hot wire (B) of 24 volt circuit to terminal (H).
- Connect wire (C) from beginning of Burner circuit (thermostat, gas valve, limits, etc.) to terminal (B).
- Connect wire (D) from end of Burner circuit to terminal (N).
- Make sure factory provided jumper bar is connected to terminal (H) and (C).

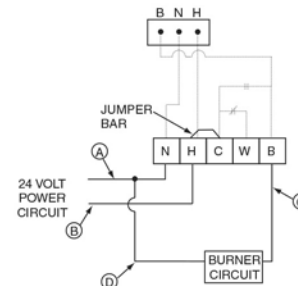

## PSE-801 with 120 Volt Burner Circuit

- Connect Hot wire (A) of 120 volt circuit to terminal (H).
- Connect Neutral wire (B) of 120 volt circuit to terminal (N).
- Connect wire (C) from beginning of Burner circuit (thermostat, gas valve, limits, etc.) to terminal (B).
- Connect wire (D) from end of Burner circuit to terminal (N).
- Connect jumper wire (E) to terminals (H) and (C).

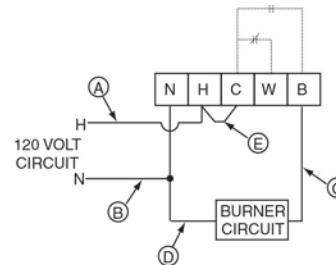

## PSE-801 with 24 Volt Burner Circuit

- Connect hot wire (A) of 120 volt circuit to terminal (H) and transformer terminal (L1).
- Connect neutral wire 'B' of 120 volt circuit to terminal (N) and transformer terminal (L2).
- Connect wire (C) from beginning of Burner circuit (thermostat, gas valve, limits, etc.) to terminal (B).
- Connect wire (D) from end of Burner circuit to transformer terminal (T2).
- Connect wire (E) from transformer terminal (T1) to terminal (C).

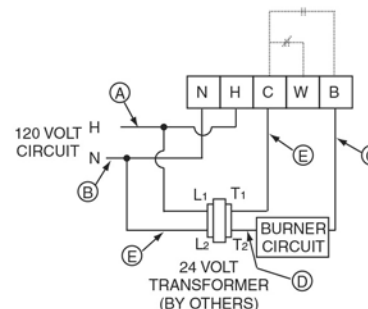

**INSTALLATION COMPLETE**

## STEP 5 - Testing

### Start-Up

- a. Before filling the system**, turn on the electric power to the boiler. Set the thermostat to "heat".
1. Upon initial power up, the Green and Red lights will flash simultaneously 4 times.
  2. The Green light will turn "ON".
  3. The Red light will continue to flash for 10-seconds Delay on Break (DOB) and then turn "ON".
  4. If a water feeder has been installed and does not have a time delay, it will turn "ON".
  5. The burner will never turn "ON" during power up, if water is off the probe.

**b. Now fill the boiler with water.**

1. When water touches the probe, the Red light will start flashing for 30-seconds Delay on Make (DOM) and then turn "OFF".
2. The burner will turn "ON" as long as there is water on the probe.
3. If a water feeder has been installed it will turn "OFF".

### Manually Testing Control

**c. Slowly drain the boiler of water.**

1. When water drops off the probe, the Red light will start flashing for 10-seconds (DOB) and then turn "ON".
2. The burner will turn "OFF".
3. If a water feeder has been installed and does not have a time delay, it should turn "ON".

**d. Depressing test button with "water on probe" for Series PSE-800 (auto reset units only):**

*(Must depress and hold the test button to activate test cycle.)*

1. When test cycle is activated the Green and Red lights will flash simultaneously.
2. After 10-seconds (DOB) the Red light will turn "ON".
3. Burner will turn "OFF".
4. The Green light will continue flashing as long as test button is depressed.
5. If a water feeder has been installed and does not have a time delay, it will turn "ON".

*(Release test button, if water is still on probe)*

6. The Green light will stop flashing and turn "ON".
7. The Red light will start flashing for 30 seconds (DOB) and then turn "OFF".
8. Burner will turn "ON" as long as there is water on the probe.
9. If a water feeder has been installed it will turn "OFF".

**f. Depressing test button with "water off probe" (for auto units only):**

*Since control is in "low water" the Green light will flash and the Red light will remain "ON". The burner will remain "OFF".*

### Troubleshooting

If control fails to operate as required, perform the following diagnostic checks:

1. Check to be sure that the water level in the boiler is at or above the level of the probe.
2. Re-check all wiring to ensure proper connections as specified in boiler manufacturer's wiring diagrams or these instructions.
3. Check to ensure that PTFE tape has not been used on the threaded connection of the probe to the boiler.
4. Re-check the electrical ground connection for the remote sensor and control unit.
5. Some foaming is common in certain boilers. If foaming occurs with priming and surging due to flux, oil or scale in the boiler or piping refer to the boiler manufacturer's recommendations for cleaning the boiler and piping.
6. Check the quality of the boiler water to ensure adequate conductance. Excessive amounts of feedwater or pH levels higher than 10.0 need to be corrected.



## WARNING



**Boiler water pH levels above 10.0 may interfere with proper operation of the low water cut-off. Levels above 10.0 must be corrected in order to ensure proper operation of the low water cut-off. Failure to follow this warning may result in property damage, personal injury or death.**



## CAUTION

**Replace Probe if:**

- PFA insulator is cracked or worn.
- Probe is loose.

**Failure to follow this caution could cause property damage, personal injury or death.**

## MAINTENANCE

### SCHEDULE:

- Test the low water cut-off annually or more frequently.
- Remove and inspect the self-cleaning probe every 5 years.
- Replace probe every 10 years.
- Replace the low water cut-off control box every 15 years.

## NOTE

**Clean probe by wiping with non-abrasive cloth and rinsing with clean water. DO NOT use sharp instruments to remove any accumulations of rust or scale.**

### COMMERCIAL WARRANTY

**Warranty.** For goods sold to commercial buyers, Seller warrants the goods sold to Buyer hereunder (with the exception of membranes, seals, gaskets, elastomer materials, coatings and other "wear parts" or consumables all of which are not warranted except as otherwise provided in the quotation or sales form) will be (i) built in accordance with the specifications referred to in the quotation or sales form, if such specifications are expressly made a part of this Agreement, and (ii) free from defects in material and workmanship for a period of one (1) year from the date of installation or two (2) years from the date of manufacture, whichever shall occur first, unless a longer period is specified in the product documentation (the "Warranty").

Except as otherwise required by law, Seller shall, at its option and at no cost to Buyer, either repair or replace any product which fails to conform with the Warranty provided Buyer gives written notice to Seller of any defects in material or workmanship within ten (10) days of the date when any defects or non-conformance are first manifest. Under either repair or replacement option, Seller shall not be obligated to remove or pay for the removal of the defective product or install or pay for the installation of the replaced or repaired product and Buyer shall be responsible for all other costs, including, but not limited to, service costs, shipping fees and expenses. Seller shall have sole discretion as to the method or means of repair or replacement. Buyer's failure to comply with Seller's repair or replacement directions shall terminate Seller's obligations under this Warranty and render the Warranty void. Any parts repaired or replaced under the Warranty are warranted only for the balance of the warranty period on the parts that were repaired or replaced. Seller shall have no warranty obligations to Buyer with respect to any product or parts of a product that have been: (a) repaired by third parties other than Seller or without Seller's written approval; (b) subject to misuse, misapplication, neglect, alteration, accident, or physical damage; (c) used in a manner contrary to Seller's instructions for installation, operation and maintenance; (d) damaged from ordinary wear and tear, corrosion, or chemical attack; (e) damaged due to abnormal conditions, vibration, failure to properly prime, or operation without flow; (f) damaged due to a defective power supply or improper electrical protection; or (g) damaged resulting from the use of accessory equipment not sold or approved by Seller. In any case of products not manufactured by Seller, there is no warranty from Seller; however, Seller will extend to Buyer any warranty received from Seller's supplier of such products.

**THE FOREGOING WARRANTY IS EXCLUSIVE AND IN LIEU OF ANY AND ALL OTHER EXPRESS OR IMPLIED WARRANTIES, GUARANTEES, CONDITIONS OR TERMS OF WHATEVER NATURE RELATING TO THE GOODS PROVIDED HEREUNDER, INCLUDING WITHOUT LIMITATION ANY IMPLIED WARRANTIES OF MERCHANTABILITY AND FITNESS FOR A PARTICULAR PURPOSE, WHICH ARE HEREBY EXPRESSLY DISCLAIMED AND EXCLUDED. EXCEPT AS OTHERWISE REQUIRED BY LAW, BUYER'S EXCLUSIVE REMEDY AND SELLER'S AGGREGATE LIABILITY FOR BREACH OF ANY OF THE FOREGOING WARRANTIES ARE LIMITED TO REPAIRING OR REPLACING THE PRODUCT AND SHALL IN ALL CASES BE LIMITED TO THE AMOUNT PAID BY THE BUYER FOR THE DEFECTIVE PRODUCT. IN NO EVENT SHALL SELLER BE LIABLE FOR ANY OTHER FORM OF DAMAGES, WHETHER DIRECT, INDIRECT, LIQUIDATED, INCIDENTAL, CONSEQUENTIAL, PUNITIVE, EXEMPLARY OR SPECIAL DAMAGES, INCLUDING BUT NOT LIMITED TO LOSS OF PROFIT, LOSS OF ANTICIPATED SAVINGS OR REVENUE, LOSS OF INCOME, LOSS OF BUSINESS, LOSS OF PRODUCTION, LOSS OF OPPORTUNITY OR LOSS OF REPUTATION.**

### LIMITED CONSUMER WARRANTY

**Warranty.** For goods sold for personal, family or household purposes, Seller warrants the goods purchased hereunder (with the exception of membranes, seals, gaskets, elastomer materials, coatings and other "wear parts" or consumables all of which are not warranted except as otherwise provided in the quotation or sales form) will be free from defects in material and workmanship for a period of one (1) year from the date of installation or two (2) years from the product date code, whichever shall occur first, unless a longer period is provided by law or is specified in the product documentation (the "Warranty").

Except as otherwise required by law, Seller shall, at its option and at no cost to Buyer, either repair or replace any product which fails to conform with the Warranty provided Buyer gives written notice to Seller of any defects in material or workmanship within ten (10) days of the date when any defects or non-conformance are first manifest. Under either repair or replacement option, Seller shall not be obligated to remove or pay for the removal of the defective product or install or pay for the installation of the replaced or repaired product and Buyer shall be responsible for all other costs, including, but not limited to, service costs, shipping fees and expenses. Seller shall have sole discretion as to the method or means of repair or replacement. Buyer's failure to comply with Seller's repair or replacement directions shall terminate Seller's obligations under this Warranty and render this Warranty void. Any parts repaired or replaced under the Warranty are warranted only for the balance of the warranty period on the parts that were repaired or replaced. The Warranty is conditioned on Buyer giving written notice to Seller of any defects in material or workmanship of warranted goods within ten (10) days of the date when any defects are first manifest.

Seller shall have no warranty obligations to Buyer with respect to any product or parts of a product that have been: (a) repaired by third parties other than Seller or without Seller's written approval; (b) subject to misuse, misapplication, neglect, alteration, accident, or physical damage; (c) used in a manner contrary to Seller's instructions for installation, operation and maintenance; (d) damaged from ordinary wear and tear, corrosion, or chemical attack; (e) damaged due to abnormal conditions, vibration, failure to properly prime, or operation without flow; (f) damaged due to a defective power supply or improper electrical protection; or (g) damaged resulting from the use of accessory equipment not sold or approved by Seller. In any case of products not manufactured by Seller, there is no warranty from Seller; however, Seller will extend to Buyer any warranty received from Seller's supplier of such products.

**THE FOREGOING WARRANTY IS PROVIDED IN PLACE OF ALL OTHER EXPRESS WARRANTIES. ALL IMPLIED WARRANTIES, INCLUDING BUT NOT LIMITED TO THE IMPLIED WARRANTIES OF MERCHANTABILITY AND FITNESS FOR A PARTICULAR PURPOSE, ARE LIMITED TO ONE (1) YEAR FROM THE DATE OF INSTALLATION OR TWO (2) YEARS FROM THE PRODUCT DATE CODE, WHICHEVER SHALL OCCUR FIRST. EXCEPT AS OTHERWISE REQUIRED BY LAW, BUYER'S EXCLUSIVE REMEDY AND SELLER'S AGGREGATE LIABILITY FOR BREACH OF ANY OF THE FOREGOING WARRANTIES ARE LIMITED TO REPAIRING OR REPLACING THE PRODUCT AND SHALL IN ALL CASES BE LIMITED TO THE AMOUNT PAID BY THE BUYER FOR THE DEFECTIVE PRODUCT. IN NO EVENT SHALL SELLER BE LIABLE FOR ANY OTHER FORM OF DAMAGES, WHETHER DIRECT, INDIRECT, LIQUIDATED, INCIDENTAL, CONSEQUENTIAL, PUNITIVE, EXEMPLARY OR SPECIAL DAMAGES, INCLUDING BUT NOT LIMITED TO LOSS OF PROFIT, LOSS OF ANTICIPATED SAVINGS OR REVENUE, LOSS OF INCOME, LOSS OF BUSINESS, LOSS OF PRODUCTION, LOSS OF OPPORTUNITY OR LOSS OF REPUTATION.**

Some states do not allow limitations on how long an implied warranty lasts, so the above limitation may not apply to you. Some states do not allow the exclusion or limitation of incidental or consequential damages, so the above exclusions may not apply to you. This warranty gives you specific legal rights, and you may also have other rights which may vary from state to state.

To make a warranty claim, check first with the dealer from whom you purchased the product or call +1-847-966-3700 for the name and location of the nearest dealer providing warranty service.

**xylem**  
Let's Solve Water

Xylem Inc.  
8200 N. Austin Avenue  
Morton Grove, Illinois 60053  
Phone: (847) 966-3700  
Fax: (847) 965-8379  
[www.xylem.com/mcdonnellmiller](http://www.xylem.com/mcdonnellmiller)

McDonnell & Miller is a trademark of Xylem Inc. or one of its subsidiaries.  
© 2020 Xylem Inc. MM-284J December 2020 Part No. 211630

