

Folder: HSC3_150

File Name: HSC3_150_4610S.pdf

B-538.2

To save this file, simply copy the file from the compact disc to your hard drive.

JOB	B & G REPRESENTATIVE	
UNIT TAG NO.	ORDER NO.	DATE
ENGINEER	SUBMITTED BY	DATE
CONTRACTOR	APPROVED BY	DATE

4x6x10S Series HSC³ Centrifugal Pump

BASE MOUNTED-DOUBLE SUCTION 4" DISCHARGE-6" SUCTION

SPECIFICATIONS:

_____ GPM _____ FT. _____ RPM
 MOTOR DATA: _____ HP _____ VOLTS
 _____ ENCL. _____ HZ. _____ Ø
 SPEC. CONSTR.: _____
 APPROXIMATE TOTAL WEIGHT _____ LBS.

MATERIALS OF CONSTRUCTION:

- CAST IRON BRONZE FITTED
- INTERNALLY SELF FLUSHING MECH. SEALS
- FABRICATED HEAVY DUTY BASEPLATE
- ANSI/OSHA COUPLING GUARD
- FLEXIBLE COUPLING
- SPACER COUPLING (OPTIONAL)
- GALVANIZED DRIP PAN (OPTIONAL)

TYPE OF SEAL:

- STANDARD SEAL CONSTRUCTION, 175 PSIG (12 BAR) WORKING PRESSURE, 125# ANSI FLANGES
- STANDARD:** CRANE TYPE 21, BUNA/CARBON-CERAMIC, 75 PSIG (5 BAR) MAXIMUM SUCTION PRESSURE, FROM -20 TO 225°F (-29 TO 107°C).
 - OPTIONAL:** CRANE TYPE 21, EPT/CARBON-CERAMIC, 75 PSIG (5 BAR) MAXIMUM SUCTION PRESSURE, FROM -20 TO 250°F (-29 TO 121°C).
 - OPTIONAL:** CRANE TYPE 21, EPT/CARBON-TUNGSTEN CARBIDE, 75 PSIG (5 BAR) MAXIMUM SUCTION PRESSURE, FROM -20 TO 250°F (-29 TO 121°C).

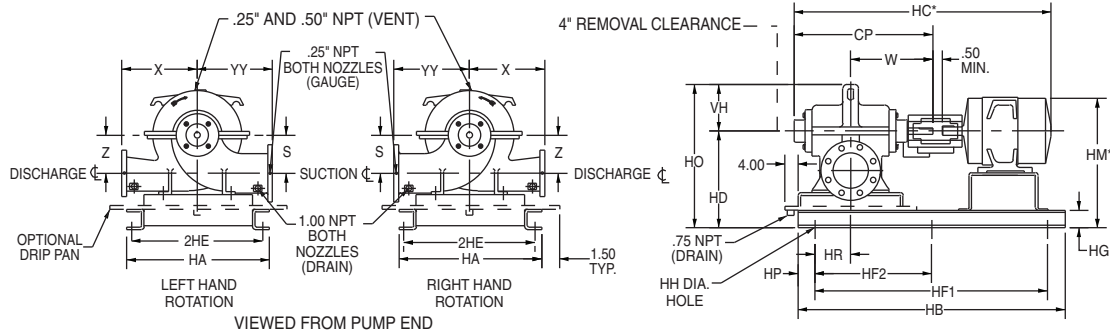

DIMENSIONS - INCHES (MM)																			
MOTOR FRAME	HA	HB	2HE	HF1	HF2	HG	HH	HP	HR	CP	HC*	HD	HM*	HO	S & Z	VH	W	X	YY
182											37 (940)		24						
184		48.00 (1219)		36.00 (914)	18.00 (457)						38 (965)		(610)						
213											41 (1041)		25						
215											43 (1092)		(635)						
254											45 (1143)		26						
256											47 (1194)		(660)						
284											48 (1219)	18.25 (464)	27	26.12 (664)					
286		58.00 (1473)		46.00 (1168)	23.00 (584)						50 (1270)		(686)						
324	24.00 (610)		22.00 (559)			4.00 (102)	1.00 (25)	6.00 (152)	4.62 (117)	22.81 (579)	51 (1295)		28		6.50 (165)	7.88 (200)	13.50 (343)	11.50 (292)	13.00 (330)
326											52 (1321)		(711)						
364											53 (1346)		29						
365											54 (1372)		(737)						
404		64.00 (1568)		52.00 (1321)	26.00 (660)						60 (1524)		30						
405											61 (1549)		(762)						
444		76.00 (1930)		64.00 (1626)	32.00 (813)	6.00 (152)					66 (1676)	20.25 (514)	32	28.12 (714)					
445											68 (1727)		(813)						

DIMENSIONS ARE SUBJECT TO CHANGE. NOT TO BE USED FOR CONSTRUCTION PURPOSES UNLESS CERTIFIED.
 * MOTOR DIMENSIONS ARE APPROXIMATE FOR "T" FRAMES. VARY BY MANUFACTURER AND MOTOR TYPE.
 SEPTEMBER, 1999