



JOB:

REPRESENTATIVE:

UNIT TAG:
ENGINEER:
CONTRACTOR:

ORDER NO.
SUBMITTED BY:
APPROVED BY:

DATE:
DATE:
DATE:



Series e-80
6x6x11B
Close Coupled In-Line Centrifugal Pump

DESCRIPTION:

The Series e-80 is a highly efficient, heavy duty, close coupled pump designed for horizontal or vertical in-line mounting. The e-80 is available in stainless steel fitted construction, with flows up to 2500 GPM, heads to 380 feet.

SPECIFICATIONS

FLOW _____ HEAD _____
 HP _____ RPM _____
 VOLTS _____
 INPUT PHASE _____
 ENCLOSURE _____
 APPROX. WEIGHT _____
 SPECIALS _____

MATERIALS OF CONSTRUCTION

- Stainless Steel Fitted
- MAXIMUM WORKING PRESSURE**
- 175 psi (12 bar) with 125# ANSI flange drilling
- 250 psi (17 bar) with 250# ANSI flange drilling (requires 80-S)
- 300 psi (21 bar) W.P. with 250# ANSI flange drilling (Requires -S and EPR-Silicon Carbide-Silicon Carbide Seal)

MOUNTING

- In-Line Piping
- Flange Supports

PUMP VARIABLE SPEED CONTROL

- Integrated Technologic® Sensorless Control (ITSC)
- Integrated Technologic® (IT)
- External input by others
- Pressure Sensor(s)
- Differential Pressure Sensor(s)
- Flow Sensor(s)
- By Others

TYPE OF SEAL

- F Standard Seal w/ Flush Line (Buna-Carbon/Ceramic)
- S Stuffing Box construction w/ Flushed Mechanical Single Seal (EPR-Tungsten Carbide/Carbon)
- PF Stuffing Box Construction w/ Flushed Packing (Graphite Impregnated PTFE)

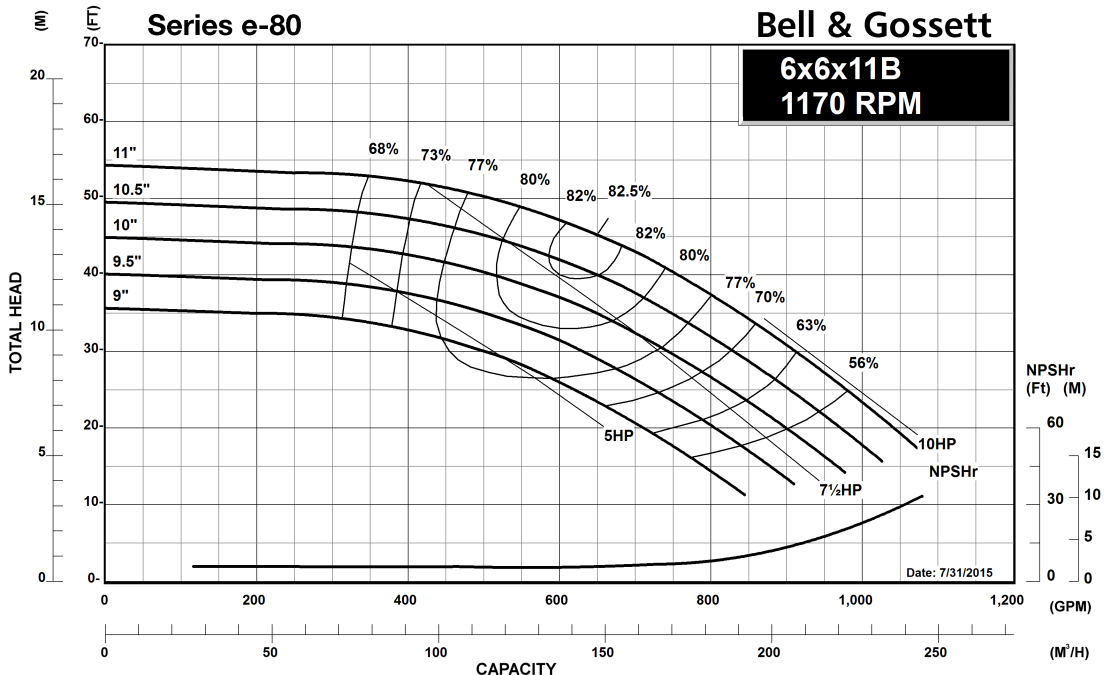



JOB:

REPRESENTATIVE:

UNIT TAG:
ENGINEER:
CONTRACTOR:

ORDER NO.
SUBMITTED BY:
APPROVED BY:

DATE:
DATE:
DATE:



Series e-80

6x6x11B

Close Coupled In-Line Centrifugal Pump

DESCRIPTION:

The Series e-80 is a highly efficient, heavy duty, close coupled pump designed for horizontal or vertical in-line mounting. The e-80 is available in stainless steel fitted construction, with flows up to 2500 GPM, heads to 380 feet.

SPECIFICATIONS

FLOW _____ HEAD _____
 HP _____ RPM _____
 VOLTS _____
 CYCLE _____ INPUT PHASE _____
 ENCLOSURE _____
 APPROX. WEIGHT _____
 SPECIALS _____

MATERIALS OF CONSTRUCTION

- Stainless Steel Fitted
- MAXIMUM WORKING PRESSURE**
- 175 psi (12 bar) with 125# ANSI flange drilling
- 250 psi (17 bar) with 250# ANSI flange drilling (requires 80-S)
- 300 psi (21 bar) W.P. with 250# ANSI flange drilling (Requires -S and EPR-Silicon Carbide-Silicon Carbide Seal)

MOUNTING

- In-Line Piping
- Flange Supports

PUMP VARIABLE SPEED CONTROL

- Integrated Technologic® Sensorless Control (ITSC)
- Integrated Technologic® (IT)
- External input by others
- Pressure Sensor(s)
- Differential Pressure Sensor(s)
- Flow Sensor(s)
- By Others

TYPE OF SEAL

- F Standard Seal w/ Flush Line (Buna-Carbon/Ceramic)
- S Stuffing Box construction w/ Flushed Mechanical Single Seal (EPR-Tungsten Carbide/Carbon)
- PF Stuffing Box Construction w/ Flushed Packing (Graphite Impregnated PTFE)

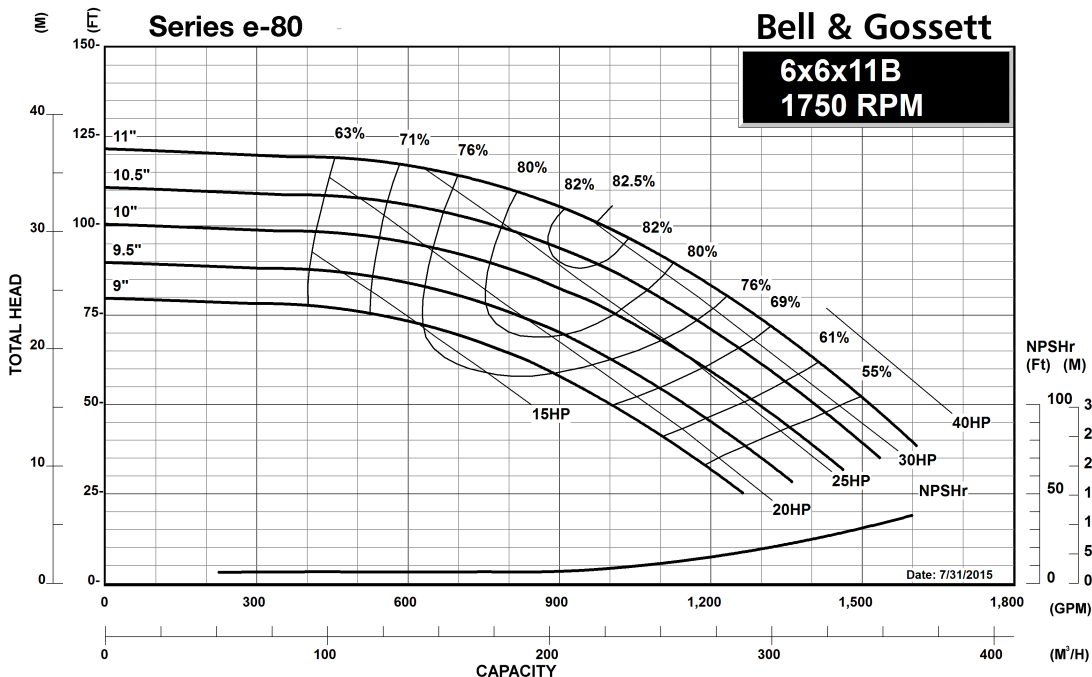

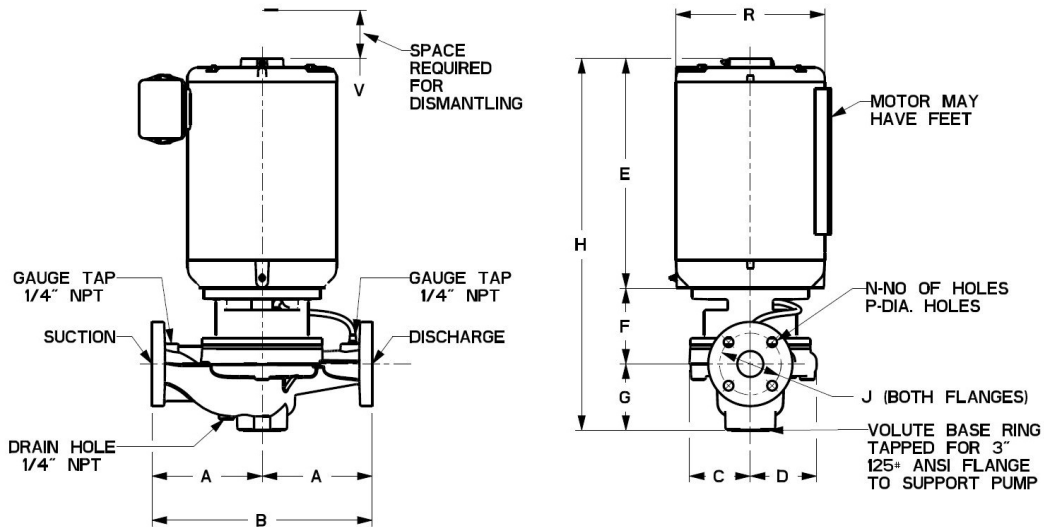

1P0355

In-Line Piping

DIMENSIONS - Inches (mm)										STANDARD SEAL									
MOTOR FRAME	A	B	C	D	E (max)	F	G	H (max)	125# ANSI			250# ANSI			R	S (Max)*	V (min)	Suct/Disch Gauge Taps (NPT)	Drain Tap (NPT)
									J	N	P	J	N	P					
213JM	16.00 (406)	32.00 (813)	8.02 (204)	10.98 (279)	19.25 (489)	4.19 (106)	8.84 (225)	32.28 (820)	9.50 (241)	8 (22)	0.88 (22)	10.63 (270)	12 (22)	0.88 (22)	14.00 (356)	0.00	5.94 (151)	0.25	0.25
215JM	16.00 (406)	32.00 (813)	8.02 (204)	10.98 (279)	19.25 (489)	4.19 (106)	8.84 (225)	32.28 (820)	9.50 (241)	8 (22)	0.88 (22)	10.63 (270)	12 (22)	0.88 (22)	14.00 (356)	0.00	5.94 (151)	0.25	0.25
254JM	16.00 (406)	32.00 (813)	8.02 (204)	10.98 (279)	24.13 (613)	4.98 (127)	8.84 (225)	37.95 (964)	9.50 (241)	8 (22)	0.88 (22)	10.63 (270)	12 (22)	0.88 (22)	17.00 (432)	0.00	5.94 (151)	0.25	0.25
256JM	16.00 (406)	32.00 (813)	8.02 (204)	10.98 (279)	24.13 (613)	4.98 (127)	8.84 (225)	37.95 (964)	9.50 (241)	8 (22)	0.88 (22)	10.63 (270)	12 (22)	0.88 (22)	17.00 (432)	0.00	5.94 (151)	0.25	0.25
284JM	16.00 (406)	32.00 (813)	8.02 (204)	10.98 (279)	23.63 (600)	4.98 (127)	8.84 (225)	37.45 (951)	9.50 (241)	8 (22)	0.88 (22)	10.63 (270)	12 (22)	0.88 (22)	16.13 (410)	4.63 (117)	5.94 (151)	0.25	0.25
286JM	16.00 (406)	32.00 (813)	8.02 (204)	10.98 (279)	25.13 (638)	4.98 (127)	8.84 (225)	38.95 (989)	9.50 (241)	8 (22)	0.88 (22)	10.63 (270)	12 (22)	0.88 (22)	16.13 (410)	4.63 (117)	5.94 (151)	0.25	0.25
324JM	16.00 (406)	32.00 (813)	8.02 (204)	10.98 (279)	26.00 (660)	4.98 (127)	8.84 (225)	39.82 (1011)	9.50 (241)	8 (22)	0.88 (22)	10.63 (270)	12 (22)	0.88 (22)	18.75 (476)	4.63 (117)	5.94 (151)	0.25	0.25

STUFFING BOX																			
MOTOR FRAME	A	B	C	D	E (max)	F	G	H (max)	125# ANSI			250# ANSI			R	S (Max)*	V (min)	Suct/Disch Gauge Taps (NPT)	Drain Tap (NPT)
									J	N	P	J	N	P					
213JP	16.00 (406)	32.00 (813)	8.02 (204)	10.98 (279)	19.25 (489)	7.56 (192)	8.84 (225)	35.65 (906)	9.50 (241)	8 (22)	0.88 (22)	10.63 (270)	12 (22)	0.88 (22)	14.00 (356)	0.00	5.94 (151)	0.25	0.25
215JP	16.00 (406)	32.00 (813)	8.02 (204)	10.98 (279)	19.25 (489)	7.19 (183)	8.84 (225)	35.28 (896)	9.50 (241)	8 (22)	0.88 (22)	10.63 (270)	12 (22)	0.88 (22)	14.00 (356)	0.00	5.94 (151)	0.25	0.25
254JP	16.00 (406)	32.00 (813)	8.02 (204)	10.98 (279)	24.13 (613)	7.81 (198)	8.84 (225)	40.78 (1036)	9.50 (241)	8 (22)	0.88 (22)	10.63 (270)	12 (22)	0.88 (22)	17.00 (432)	0.00	5.94 (151)	0.25	0.25
256JP	16.00 (406)	32.00 (813)	8.02 (204)	10.98 (279)	24.13 (613)	7.81 (198)	8.84 (225)	40.78 (1036)	9.50 (241)	8 (22)	0.88 (22)	10.63 (270)	12 (22)	0.88 (22)	17.00 (432)	0.00	5.94 (151)	0.25	0.25
284JP	16.00 (406)	32.00 (813)	8.02 (204)	10.98 (279)	23.63 (600)	7.81 (198)	8.84 (225)	40.28 (1023)	9.50 (241)	8 (22)	0.88 (22)	10.63 (270)	12 (22)	0.88 (22)	16.13 (410)	4.63 (117)	5.94 (151)	0.25	0.25
286JP	16.00 (406)	32.00 (813)	8.02 (204)	10.98 (279)	25.13 (638)	7.81 (198)	8.84 (225)	41.78 (1061)	9.50 (241)	8 (22)	0.88 (22)	10.63 (270)	12 (22)	0.88 (22)	16.13 (410)	4.63 (117)	5.94 (151)	0.25	0.25
324JP	16.00 (406)	32.00 (813)	8.02 (204)	10.98 (279)	26.00 (660)	7.81 (198)	8.84 (225)	42.65 (1083)	9.50 (241)	8 (22)	0.88 (22)	10.63 (270)	12 (22)	0.88 (22)	18.75 (476)	4.63 (117)	5.94 (151)	0.25	0.25

Dimensions are subject to change. Not to be used for construction purposes unless certified.

NOTE: For Single phase Motors add 1" to dimensions E & H.

*Dimensions are for ODP Motors. For TEFC add S dimension to dimensions E & H.



Xylem Inc.
 8200 N. Austin Avenue, Morton Grove, IL 60053
 Phone: (847)966-3700 Fax: (847)965-8379
 www.xylem.com/bellgossett

Bell & Gossett is a trademark of Xylem Inc. or one of its subsidiaries. © 2019 Xylem Inc.

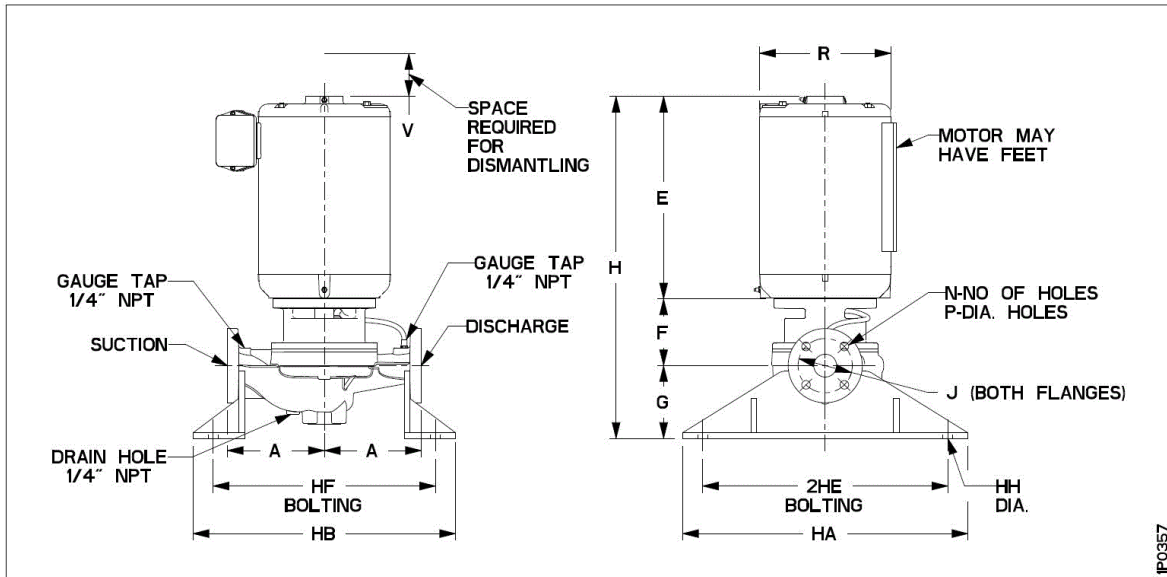

Flange Support Mounting

DIMENSIONS - Inches (mm)											STANDARD SEAL										
MOTOR FRAME	A	HF BOLTING	HB	2HE BOLTING	HA	HH DIA	E (max)	F	G	H (max)	125# ANSI			250# ANSI			R	S (Max)*	V (min)	Suct/Disch Gauge Taps (NPT)	Drain Tap (NPT)
											J	N	P	J	N	P					
213JM	16.00 (406)	34.78 (883)	38.28 (972)	22.50 (572)	26.00 (660)	1.00 (25)	19.25 (489)	4.19 (106)	9.88 (251)	33.31 (846)	9.50 (241)	8 (22)	0.88 (22)	10.63 (270)	12 (22)	0.88 (22)	14.00 (356)	0.00	5.94 (151)	0.25	0.25
215JM	16.00 (406)	34.78 (883)	38.28 (972)	22.50 (572)	26.00 (660)	1.00 (25)	19.25 (489)	4.19 (106)	9.88 (251)	33.31 (846)	9.50 (241)	8 (22)	0.88 (22)	10.63 (270)	12 (22)	0.88 (22)	14.00 (356)	0.00	5.94 (151)	0.25	0.25
254JM	16.00 (406)	34.78 (883)	38.28 (972)	22.50 (572)	26.00 (660)	1.00 (25)	24.13 (613)	4.98 (127)	9.88 (251)	38.98 (990)	9.50 (241)	8 (22)	0.88 (22)	10.63 (270)	12 (22)	0.88 (22)	17.00 (432)	0.00	5.94 (151)	0.25	0.25
256JM	16.00 (406)	34.78 (883)	38.28 (972)	22.50 (572)	26.00 (660)	1.00 (25)	24.13 (613)	4.98 (127)	9.88 (251)	38.98 (990)	9.50 (241)	8 (22)	0.88 (22)	10.63 (270)	12 (22)	0.88 (22)	17.00 (432)	0.00	5.94 (151)	0.25	0.25
284JM	16.00 (406)	34.78 (883)	38.28 (972)	22.50 (572)	26.00 (660)	1.00 (25)	23.63 (600)	4.98 (127)	9.88 (251)	38.48 (977)	9.50 (241)	8 (22)	0.88 (22)	10.63 (270)	12 (22)	0.88 (22)	16.13 (410)	4.63 (117)	5.94 (151)	0.25	0.25
286JM	16.00 (406)	34.78 (883)	38.28 (972)	22.50 (572)	26.00 (660)	1.00 (25)	25.13 (638)	4.98 (127)	9.88 (251)	39.98 (1016)	9.50 (241)	8 (22)	0.88 (22)	10.63 (270)	12 (22)	0.88 (22)	16.13 (410)	4.63 (117)	5.94 (151)	0.25	0.25
324JM	16.00 (406)	34.78 (883)	38.28 (972)	22.50 (572)	26.00 (660)	1.00 (25)	26.00 (660)	4.98 (127)	9.88 (251)	40.86 (1038)	9.50 (241)	8 (22)	0.88 (22)	10.63 (270)	12 (22)	0.88 (22)	18.75 (476)	4.63 (117)	5.94 (151)	0.25	0.25

STUFFING BOX																					
MOTOR FRAME	A	HF BOLTING	HB	ZHE BOLTING	HA	HH DIA	E (max)	F	G	H (max)	125# ANSI			250# ANSI			R	S (Max)*	V (min)	Suct/Disch Gauge Taps (NPT)	Drain Tap (NPT)
											J	N	P	J	N	P					
213JP	16.00 (406)	34.78 (883)	38.28 (972)	22.50 (572)	26.00 (660)	1.00 (25)	19.25 (489)	7.56 (192)	9.88 (251)	36.69 (932)	9.50 (241)	8 (22)	0.88 (22)	10.63 (270)	12 (22)	0.88 (22)	14.00 (356)	0.00	5.94 (151)	0.25	0.25
215JP	16.00 (406)	34.78 (883)	38.28 (972)	22.50 (572)	26.00 (660)	1.00 (25)	19.25 (489)	7.19 (183)	9.88 (251)	36.31 (922)	9.50 (241)	8 (22)	0.88 (22)	10.63 (270)	12 (22)	0.88 (22)	14.00 (356)	0.00	5.94 (151)	0.25	0.25
254JP	16.00 (406)	34.78 (883)	38.28 (972)	22.50 (572)	26.00 (660)	1.00 (25)	24.13 (613)	7.81 (198)	9.88 (251)	41.81 (1062)	9.50 (241)	8 (22)	0.88 (22)	10.63 (270)	12 (22)	0.88 (22)	17.00 (432)	0.00	5.94 (151)	0.25	0.25
256JP	16.00 (406)	34.78 (883)	38.28 (972)	22.50 (572)	26.00 (660)	1.00 (25)	24.13 (613)	7.81 (198)	9.88 (251)	41.81 (1062)	9.50 (241)	8 (22)	0.88 (22)	10.63 (270)	12 (22)	0.88 (22)	17.00 (432)	0.00	5.94 (151)	0.25	0.25
284JP	16.00 (406)	34.78 (883)	38.28 (972)	22.50 (572)	26.00 (660)	1.00 (25)	23.63 (600)	7.81 (198)	9.88 (251)	41.31 (1049)	9.50 (241)	8 (22)	0.88 (22)	10.63 (270)	12 (22)	0.88 (22)	16.13 (410)	4.63 (117)	5.94 (151)	0.25	0.25
286JP	16.00 (406)	34.78 (883)	38.28 (972)	22.50 (572)	26.00 (660)	1.00 (25)	25.13 (638)	7.81 (198)	9.88 (251)	42.81 (1087)	9.50 (241)	8 (22)	0.88 (22)	10.63 (270)	12 (22)	0.88 (22)	16.13 (410)	4.63 (117)	5.94 (151)	0.25	0.25
324JP	16.00 (406)	34.78 (883)	38.28 (972)	22.50 (572)	26.00 (660)	1.00 (25)	26.00 (660)	7.81 (198)	9.88 (251)	43.69 (1110)	9.50 (241)	8 (22)	0.88 (22)	10.63 (270)	12 (22)	0.88 (22)	18.75 (476)	4.63 (117)	5.94 (151)	0.25	0.25

Dimensions are subject to change. Not to be used for construction purposes unless certified.

NOTE: For Single phase Motors add 1" to dimensions E & H.

*Dimensions are for ODP Motors. For TEFC add S dimension to dimensions E & H.



Xylem Inc.
 8200 N. Austin Avenue, Morton Grove, IL 60053 Phone:
 (847)966-3700 Fax: (847)965-8379
 www.xylem.com/bellgossett

Bell & Gossett is a trademark of Xylem Inc. or one of its subsidiaries. © 2019 Xylem Inc.

Series e-80 6x6x11B Close Coupled In-Line Centrifugal Pump With Integrated Technologic® Control

B-139.36B

TECHNOLOGIC STANDARD FEATURES	
CONTROL METHOD WITH INTEGRATED TECHNOLOGIC® SENSORLESS CONTROL (ITSC)	Factory configured for sensorless operation.
CONTROL METHOD WITH INTEGRATED TECHNOLOGIC® (IT)	Field configurable for sensor by others, building management system input, or optional sensor(s) provided.
ENCLOSURE	NEMA 12 (same as IP55 & UL type 12)
POWER DISCONNECT SWITCH	Included standard. Fused Disconnect Switch optional with three phase input voltage.
HARMONIC SUPPRESSION	Integrated non-saturating dual DC link reactors provide better harmonic performance than a 5% AC line reactor.
COOLING	Fan-cooled through temperature controlled and easy replacement.
AMBIENT TEMPERATURE RATING	14°F to 113°F (-10°C to 45°C)
COMMUNICATION PROTOCOLS	BACnet, Modbus RTU, N2 Metasys, FLN Apogee
ANALOG INPUTS	2 configurable for either voltage (0 to 10VDC) or current(0/4 to 20mA)
ANALOG OUTPUTS	1 (0/4 to 20mA) up to 500 ohm load accurate to 1% of full scale
DIGITAL INPUTS	4 (0 to 24VDC), NPN or PNP, 0 to 24VDC, on 5 msec scan interval, Up to 2 can be configured as pulse inputs.
DIGITAL OUTPUTS	2 (0 to 24VDC), 40mA max current, configurable as pulse outputs.
RELAY OUTPUTS	2 programmable, 240VAC or 400VAC up to 2 A
MINIMUM CONTROL HEAD	_____ ft (default set to 40% of design head if not unknown)

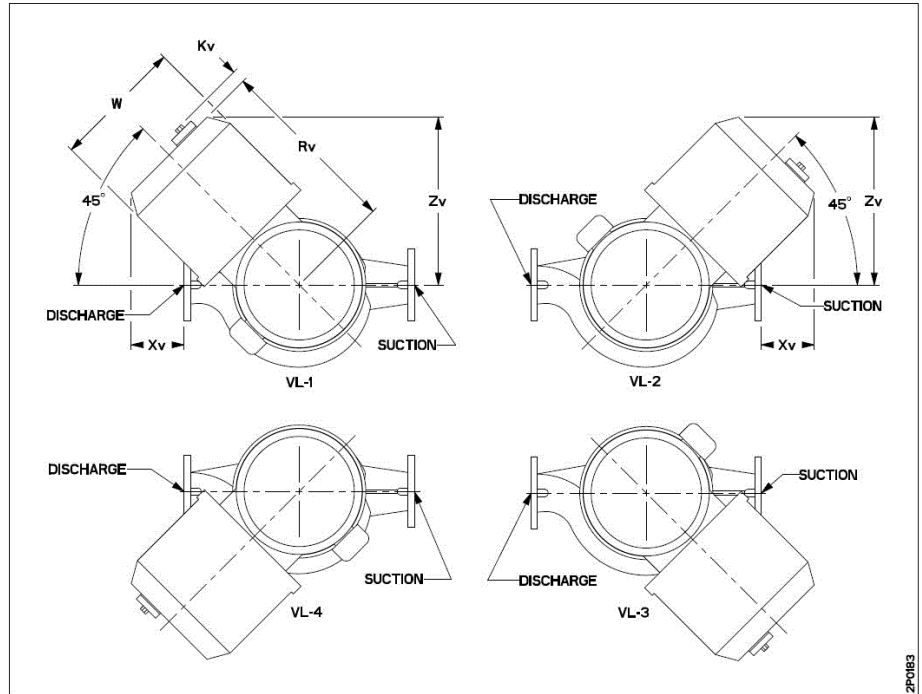
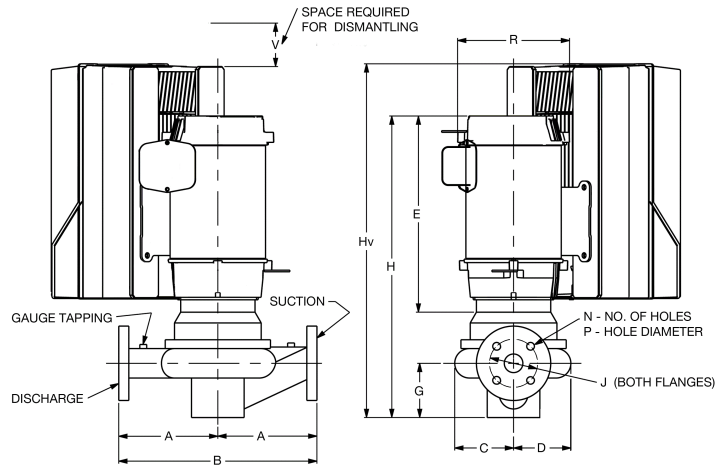

Xylem Inc.
8200 N. Austin Avenue, Morton Grove, IL 60053 Phone:
(847)966-3700 Fax: (847)965-8379
www.xylem.com/bellgossett

Bell & Gossett is a trademark of Xylem Inc. or one of its subsidiaries. © 2019 Xylem Inc.

**Series e-80 6x6x11B Close Coupled In-Line Centrifugal Pump
With Integrated Technologic® Control**

B-139.36B

DIMENSIONS - Inches (mm)		STANDARD SEAL					STUFFING BOX						
MOTOR FRAME	VFD	Rv	Zv	W	Hv	Xv	MOTOR FRAME	VFD	Rv	Zv	W	Hv	Xv
213JM	A5	13.53 (344)	12.56 (319)	9.50 (241)	34.86 (885)	3.44 (87)	213JP	A5	13.53 (344)	12.56 (319)	9.50 (241)	38.14 (969)	3.44 (87)
	B1	15.82 (402)	14.16 (360)	9.50 (241)	36.11 (917)	5.04 (128)		B1	15.82 (402)	14.16 (360)	9.50 (241)	39.39 (1001)	5.04 (128)
	B2	15.82 (402)	14.16 (360)	9.50 (241)	41.85 (1063)	5.04 (128)		B2	15.82 (402)	14.16 (360)	9.50 (241)	45.13 (1146)	5.04 (128)
215JM	A5	13.53 (344)	12.56 (319)	9.50 (241)	33.39 (848)	3.44 (87)	215JP	A5	13.53 (344)	12.56 (319)	9.50 (241)	36.67 (931)	3.44 (87)
	B1	15.82 (402)	14.16 (360)	9.50 (241)	34.64 (880)	5.04 (128)		B1	15.82 (402)	14.16 (360)	9.50 (241)	37.92 (963)	5.04 (128)
	B2	15.82 (402)	14.16 (360)	9.50 (241)	40.38 (1026)	5.04 (128)		B2	15.82 (402)	14.16 (360)	9.50 (241)	43.66 (1109)	5.04 (128)
	C1	17.79 (452)	17.36 (441)	12.10 (307)	42.40 (1077)	8.24 (209)		C1	17.79 (452)	17.36 (441)	12.10 (307)	45.68 (1160)	8.24 (209)
254JM	A5	14.53 (369)	13.27 (337)	9.50 (241)	37.86 (962)	2.73 (69)	254JP	A5	14.53 (369)	13.27 (337)	9.50 (241)	40.69 (1033)	2.73 (69)
	B1	16.83 (427)	14.92 (379)	9.50 (241)	40.86 (1038)	1.08 (27)		B1	16.83 (427)	14.92 (379)	9.50 (241)	43.69 (1110)	1.08 (27)
	B2	16.83 (427)	14.92 (379)	9.50 (241)	45.32 (1151)	1.08 (27)		B2	16.83 (427)	14.92 (379)	9.50 (241)	48.15 (1223)	1.08 (27)
	C1	18.80 (477)	18.12 (460)	12.10 (307)	46.58 (1183)	4.28 (109)		C1	18.80 (477)	18.12 (460)	12.10 (307)	49.41 (1255)	4.28 (109)
256JM	A5	14.53 (369)	13.27 (337)	9.50 (241)	37.86 (962)	2.73 (69)	256JP	A5	14.53 (369)	13.27 (337)	9.50 (241)	40.69 (1033)	2.73 (69)
	B1	16.83 (427)	14.92 (379)	9.50 (241)	40.86 (1038)	1.08 (27)		B1	16.83 (427)	14.92 (379)	9.50 (241)	43.02 (1093)	1.08 (27)
	B2	16.83 (427)	14.92 (379)	9.50 (241)	44.69 (1135)	1.08 (27)		B2	16.83 (427)	14.92 (379)	9.50 (241)	47.52 (1207)	1.08 (27)
	C1	18.80 (477)	18.12 (460)	12.10 (307)	45.95 (1167)	4.28 (109)		C1	18.80 (477)	18.12 (460)	12.10 (307)	48.78 (1239)	4.28 (109)
	C2	19.58 (497)	20.42 (519)	14.60 (371)	50.61 (1285)	6.58 (167)		C2	19.58 (497)	20.42 (519)	14.60 (371)	53.44 (1357)	6.58 (167)
284JM	B1	17.58 (446)	15.45 (393)	9.50 (241)	39.61 (1006)	0.55 (14)	284JP	B1	17.58 (446)	15.45 (393)	9.50 (241)	42.44 (1078)	0.55 (14)
	B2	17.58 (446)	15.45 (393)	9.50 (241)	44.07 (1119)	0.55 (14)		B2	17.58 (446)	15.45 (393)	9.50 (241)	46.90 (1191)	0.55 (14)
	C1	19.58 (497)	17.63 (448)	12.09 (307)	46.47 (1180)	1.63 (41)		C1	19.58 (497)	17.63 (448)	12.09 (307)	49.30 (1252)	1.63 (41)
	C2	20.36 (517)	19.93 (506)	14.59 (371)	49.62 (1260)	3.93 (100)		C2	20.36 (517)	19.93 (506)	14.59 (371)	52.45 (1332)	3.93 (100)
286JM	B2	17.58 (446)	15.45 (393)	9.50 (241)	45.56 (1157)	0.55 (14)	286JP	B2	17.58 (446)	15.45 (393)	9.50 (241)	48.39 (1229)	0.55 (14)
	C1	19.58 (497)	17.63 (448)	12.09 (307)	47.97 (1218)	1.63 (41)		C1	19.58 (497)	17.63 (448)	12.09 (307)	50.80 (1290)	1.63 (41)
	C2	20.36 (517)	19.93 (506)	14.59 (371)	51.12 (1298)	3.93 (100)		C2	20.36 (517)	19.93 (506)	14.59 (371)	53.95 (1370)	3.93 (100)
324JM	B2	18.58 (472)	16.16 (410)	9.50 (241)	44.90 (1141)	0.16 (4)	324JP	B2	18.58 (472)	16.16 (410)	9.50 (241)	47.73 (1212)	0.16 (4)
	C1	20.58 (523)	18.33 (466)	12.09 (307)	45.25 (1149)	2.33 (59)		C1	20.58 (523)	18.33 (466)	12.09 (307)	48.08 (1221)	2.33 (59)

NOTE: Drives with single phase input have three phase output and include three phase motors.
Kv=2 (50)



Xylem Inc.
8200 N. Austin Avenue, Morton Grove, IL 60053 Phone:
(847)966-3700 Fax: (847)965-8379
www.xylem.com/bellgossett

Bell & Gossett is a trademark of Xylem Inc. or one of its subsidiaries. © 2019 Xylem Inc.