

JOB:	REPRESENTATIVE:	
UNIT TAG:	ORDER NO.:	DATE:
ENGINEER:	SUBMITTED BY:	DATE:
CONTRACTOR:	APPROVED BY:	DATE:

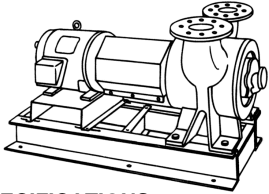

4x4x9-1/4L

VSC Centrifugal Pumps

Base Mounted - Double suction

SPECIFICATIONS

FLOW _____ HEAD _____

HP _____ RPM _____

VOLTS _____

CYCLE _____ PHASE _____

ENCLOSURE _____

APPROX. WEIGHT _____

SPECIALS _____

MATERIALS OF CONSTRUCTION

BRONZE FITTED

FEATURES

- ANSI/OSHA Coupling Guard
- Center Drop Out Spacer Coupling
- Fabricated Heavy Duty Baseplate

TYPE OF SEAL

Standard Seal Construction, 175 PSIG (12 Bar) working pressure, 125# ANSI flanges.
std. flush(-F)

- Standard: Crane Type 21, Buna/Carbon-Ceramic, 90 psig (6 bar) max. suction pressure
Temp. range: -20 to 225°F (-29 to 107 °C).
- Optional: Crane Type 21, EPR/Carbon-Tungsten 90 psig (6 bar) max. suction pressure,
Temp. range: -20 to 250 °F (-29 to 121 °C).
- Optional: Crane Type 2, Buna/Carbon-Ceramic, 175 psig (6 bar) max. suction pressure
Temp. range: -20 to 225 °F (-29 to 107 °C).

Standard Seal Construction, 300 PSIG (20 Bar) working pressure, 250# ANSI flanges.

- Standard: Crane Type 2, Buna/Carbon-Ceramic, 180 psig (12 bar) max. suction pressure
Temp. range: -20 to 225°F (-29 to 107 °C).
- Optional: Crane Type 2, EPR/Carbon-Tungsten, 240 psig (16 bar) max. suction pressure
Temp. range: -20 to 250 °F (-29 to 121 °C).

Stuffing Box Construction, 175 PSIG (12 Bar) working press., 125# ANSI flanges. External flush to seal.

- Standard: -S Configuration, Durametallic RO, EPR/Carbon-Tungsten, 175 psig (12 bar) max. suction
pressure, Temp. range: -20 to 300 °F* (-29 to 149 °C).
- Optional: -PF Configuration
Packing (Non-Asbestos)

Stuffing Box Construction, 300 PSIG (20 Bar) working press., 250# ANSI flanges. External flush to seal.

- Standard: -S Configuration, Durametallic RO, EPR/Carbon-Tungsten, 300 PSIG (20 Bar) max. suction
pressure, Temp. range: -20 to 300 °F* (-29 to 149 °C).

* For operating temperatures above 250°F, a cooled flush is required. On closed systems, cooling is accomplished by inserting the brazed place heat exchanger kit in the flush line to cool the fluid.

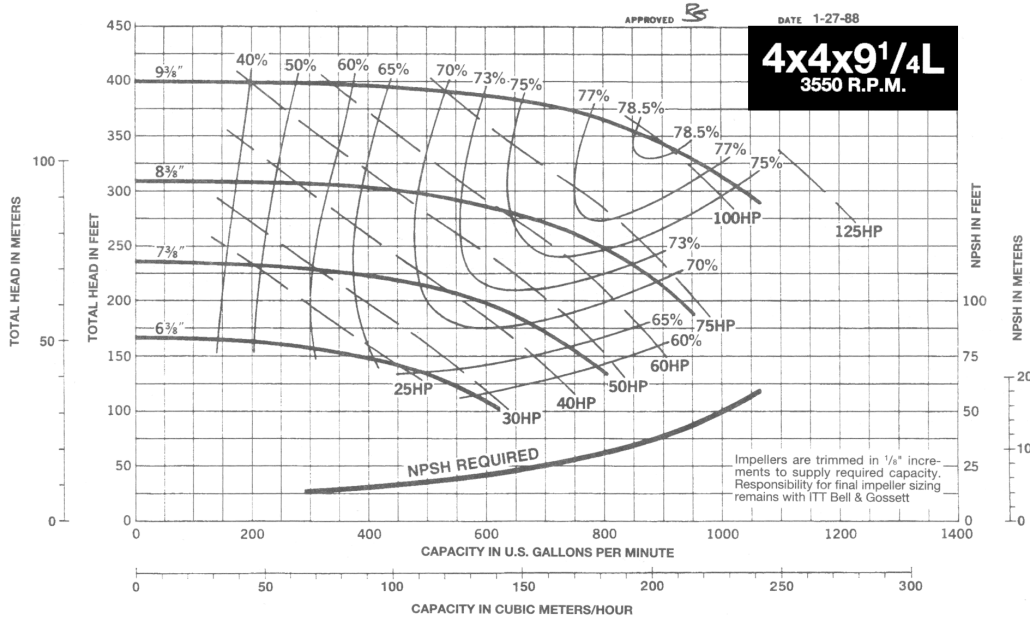

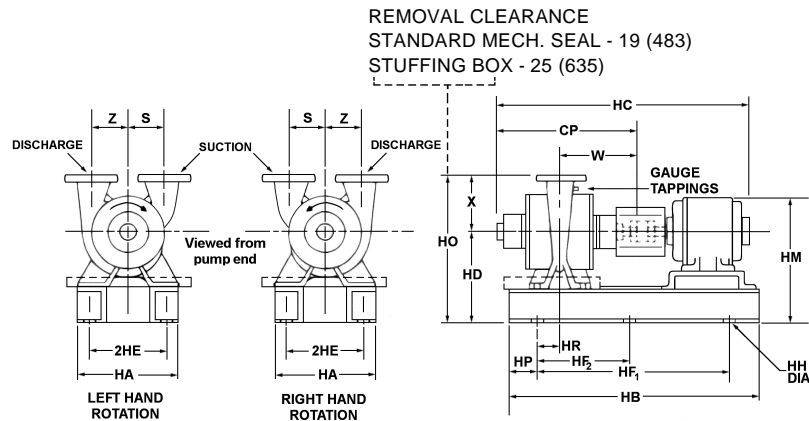

FLANGE DIMENSIONS IN INCHES (MM)			
	SIZE	THICKNESS	O.D.
Discharge	4" (102)	1-1/4 (32)	9-1/2 (241)
Suction	4" (102)	1-1/4 (32)	9-1/2 (241)

RIGHT HAND ROTATION IS FURNISHED UNLESS OTHERWISE SPECIFIED.
NOTE: EPDM COUPLINGS ARE STANDARD ON PUMPS WITH MOTOR FRAME SIZES THRU 324T.

DIMENSIONS - Inches (mm) STANDARD SEAL VSC, VSC-F

MOTOR FRAME	DIMENSIONS - INCHES (MM)																
	CP	HA	HB	HC MAX.	HD	2HE	HF ₁	HF ₂	HH	HM MAX.	HO	HP	HR	S	W	X	Z
254T	19 (483)	19-1/2 (495)	43-3/8 (1102)	48-1/8 (1222)	13-1/4 (337)	17 (432)	35-3/8 (899)	17-5/8 (448)	7/8 (22)	20-1/8 (511)	22-3/4 (578)	4 (102)	2 (51)	6 (152)	10-3/4 (273)	9-1/2 (241)	6 (152)
256T	19 (483)	19-1/2 (495)	43-3/8 (1102)	49-7/8 (1267)	13-1/4 (337)	17 (432)	38-13/16 (986)	19-3/8 (492)	7/8 (22)	20-1/8 (511)	22-3/4 (578)	5 (127)	1 (25)	6 (152)	10-3/4 (273)	9-1/2 (241)	6 (152)
284TS	19 (483)	19-1/2 (495)	49-5/8 (1260)	49-1/4 (1251)	13-1/4 (337)	17 (432)	38-13/16 (986)	19-3/8 (492)	7/8 (22)	21-1/4 (540)	22-3/4 (578)	5 (127)	1 (25)	6 (152)	10-3/4 (273)	9-1/2 (241)	6 (152)
286TS	19 (483)	19-1/2 (495)	49-5/8 (1260)	50-3/4 (1289)	13-1/4 (337)	17 (432)	38-13/16 (986)	19-3/8 (492)	7/8 (22)	21-1/4 (540)	22-3/4 (578)	5 (127)	1 (25)	6 (152)	10-3/4 (273)	9-1/2 (241)	6 (152)
324TS	19 (483)	19-1/2 (495)	49-5/8 (1260)	52-5/8 (1337)	14-1/4 (362)	17 (432)	38-13/16 (986)	19-3/8 (492)	7/8 (22)	23-3/8 (594)	23-3/4 (603)	5 (127)	1 (25)	6 (152)	10-3/4 (273)	9-1/2 (241)	6 (152)
326TS	19 (483)	19-1/2 (495)	49-5/8 (1260)	54-1/8 (1375)	14-1/4 (362)	17 (432)	38-13/16 (986)	19-3/8 (492)	7/8 (22)	23-3/8 (594)	23-3/4 (603)	5 (127)	1 (25)	6 (152)	10-3/4 (273)	9-1/2 (241)	6 (152)
364TS	19 (483)	19-1/2 (495)	49-5/8 (1260)	55-3/4 (1416)	15-1/4 (387)	17 (432)	38-13/16 (986)	19-3/8 (492)	7/8 (22)	25-1/2 (648)	24-3/4 (629)	5 (127)	1 (25)	6 (152)	10-3/4 (273)	9-1/2 (241)	6 (152)
365TS	19 (483)	19-1/2 (495)	49-5/8 (1260)	56-3/8 (1432)	15-1/4 (387)	17 (432)	38-13/16 (986)	19-3/8 (492)	7/8 (22)	25-1/2 (648)	24-3/4 (629)	5 (127)	1 (25)	6 (152)	10-3/4 (273)	9-1/2 (241)	6 (152)
404TS	19 (483)	19-1/2 (495)	49-5/8 (1260)	58-5/8 (1489)	14 (356)	17 (432)	38-13/16 (986)	19-3/8 (492)	7/8 (22)	25-7/8 (657)	23-1/2 (597)	5 (127)	1 (25)	6 (152)	10-3/4 (273)	9-1/2 (241)	6 (152)

STUFFING BOX VSC-PF, VSC-S, VSC-D

MOTOR FRAME	DIMENSIONS - INCHES (MM)																
	CP	HA	HB	HC MAX.	HD	2HE	HF ₁	HF ₂	HH	HM MAX.	HO	HP	HR	S	W	X	Z
254T	25-1/4 (641)	19-1/2 (495)	49-5/8 (1260)	54-3/4 (1391)	13-1/4 (337)	17 (432)	38-13/16 (986)	19-3/8 (492)	7/8 (22)	20-1/8 (511)	22-3/4 (578)	5 (127)	1 (25)	6 (152)	13-7/8 (352)	9-1/2 (241)	6 (152)
256T	25-1/4 (641)	19-1/2 (495)	49-5/8 (1260)	56-1/8 (1426)	13-1/4 (337)	17 (432)	38-13/16 (986)	19-3/8 (492)	7/8 (22)	20-1/8 (511)	22-3/4 (578)	5 (127)	1 (25)	6 (152)	13-7/8 (352)	9-1/2 (241)	6 (152)
284TS	25-1/4 (641)	19-1/2 (495)	49-5/8 (1260)	55-1/2 (1410)	13-1/4 (337)	17 (432)	38-13/16 (986)	19-3/8 (492)	7/8 (22)	21-1/4 (540)	22-3/4 (578)	5 (127)	1 (25)	6 (152)	13-7/8 (352)	9-1/2 (241)	6 (152)
286TS	25-1/4 (641)	19-1/2 (495)	49-5/8 (1260)	57 (1448)	13-1/4 (337)	17 (432)	38-13/16 (986)	19-3/8 (492)	7/8 (22)	21-1/4 (540)	22-3/4 (578)	5 (127)	1 (25)	6 (152)	13-7/8 (352)	9-1/2 (241)	6 (152)
324TS	25-1/4 (641)	19-1/2 (495)	49-5/8 (1260)	58-7/8 (1495)	14-1/4 (362)	17 (432)	38-13/16 (986)	19-3/8 (492)	7/8 (22)	23-3/8 (594)	23-3/4 (603)	5 (127)	1 (25)	6 (152)	13-7/8 (352)	9-1/2 (241)	6 (152)
326TS	25-1/4 (641)	19-1/2 (495)	49-5/8 (1260)	60-3/8 (1534)	14-1/4 (362)	17 (432)	38-13/16 (986)	19-3/8 (492)	7/8 (22)	23-3/8 (594)	23-3/4 (603)	5 (127)	1 (25)	6 (152)	13-7/8 (352)	9-1/2 (241)	6 (152)
364TS	25-1/4 (641)	19-1/2 (495)	49-5/8 (1260)	62 (1575)	15-1/4 (387)	17 (432)	38-13/16 (986)	19-3/8 (492)	7/8 (22)	25-1/2 (648)	24-3/4 (629)	5 (127)	1 (25)	6 (152)	13-7/8 (352)	9-1/2 (241)	6 (152)
365TS	25-1/4 (641)	19-1/2 (495)	49-5/8 (1260)	62-5/8 (1591)	15-1/4 (387)	17 (432)	38-13/16 (986)	19-3/8 (492)	7/8 (22)	25-1/2 (648)	24-3/4 (629)	5 (127)	1 (25)	6 (152)	13-7/8 (352)	9-1/2 (241)	6 (152)
404TS	25-1/4 (641)	19-1/2 (495)	49-5/8 (1260)	64-7/8 (1648)	14 (356)	17 (432)	38-13/16 (986)	19-3/8 (492)	7/8 (22)	25-7/8 (657)	23-1/2 (597)	5 (127)	1 (25)	6 (152)	13-7/8 (352)	9-1/2 (241)	6 (152)

Dimensions are subject to change. Not to be used for construction purposes unless certified.

Xylem Inc.
8200 N. Austin Avenue
Morton Grove, IL 60053
Phone: (847)966-3700
Fax: (847)965-8379
www.bellgossett.com

