

JOB:	REPRESENTATIVE:	
UNIT TAG:	ORDER NO.	DATE:
ENGINEER:	SUBMITTED BY:	DATE:
CONTRACTOR:	APPROVED BY:	DATE:

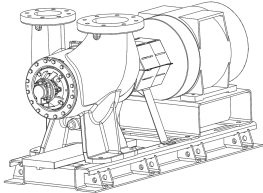

Model VSC 8x10x13 1/2 A Double Suction Split Case Pump



SPECIFICATIONS

FLOW _____ HEAD _____
 HP _____ RPM _____
 VOLTS _____
 CYCLE _____ PHASE _____
 ENCLOSURE _____
 APPROX. WEIGHT _____
 SPECIALS _____

STANDARD MATERIALS OF CONSTRUCTION

- Cast Iron Bronze Fitted
- Heavy Duty Maintenance Free Bearings
- Alignment Friendly Coupling
- Heavy Duty Groutless Baseplate
- ANSI/OSHA Coupling Guard
- ISO 1940-1:2003 Impeller Balance

OPTIONAL MATERIALS OF CONSTRUCTION

- Galvanized Drip Pan
- Spacer Coupling

TYPE OF SEAL AND WORKING PRESSURE

- Standard:** 175 PSIG (12 BAR) max. working pressure, flat face flanges, 125# ANSI flange drilling, Unitized mechanical seal, EPR/Carbon/Silicon Carbide, 175 PSIG (12 BAR) max. suction pressure, 0 to 300°F (-18 to 149°C)
- Optional:** 300 PSIG (20 BAR) max. working pressure, flat face flanges, 250# ANSI flange drilling, Unitized mechanical seal, EPR/Carbon/Silicon Carbide, 200 PSIG (13.7 BAR) max. suction pressure, 0 to 300°F (-18 to 149°C)
- Optional:** 300 PSIG (20 BAR) max. working pressure, flat face flanges, 250# ANSI flange drilling, balanced mechanical seal, EPR/Graphite loaded Silicon Carbide on Graphite loaded Silicon Carbide, 300 PSIG (20 BAR) max. suction pressure, 0 to 300°F (-18 to 149°C)

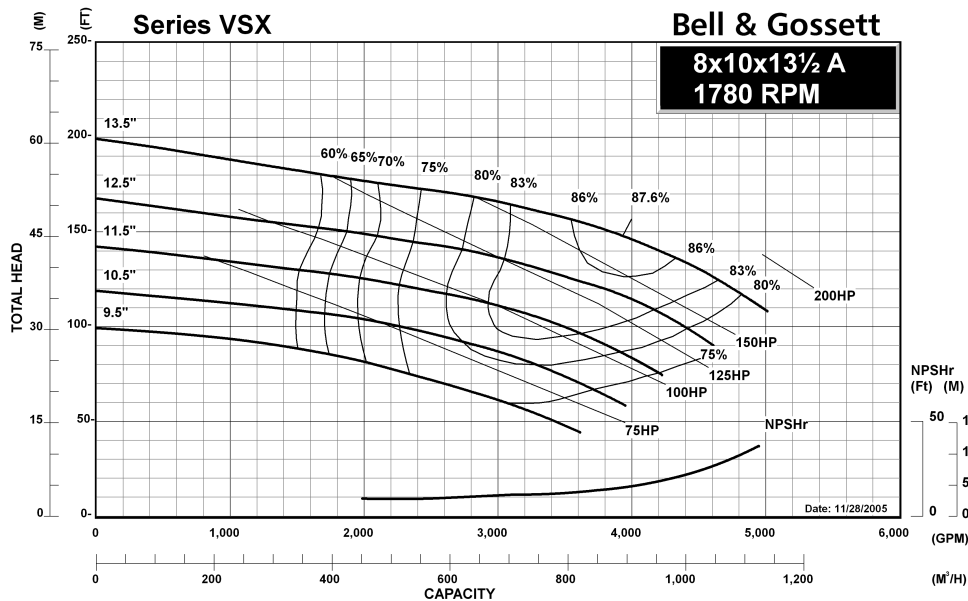

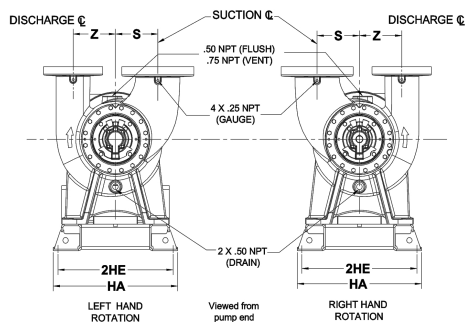

FLANGE DIMENSIONS IN INCHES (MM)			
	SIZE	THICKNESS	O.D.
Discharge	8"	1.81 (46)	14.75 (375)
Suction	10"	2.07 (52)	17.00 (432)

FLANGES ARE 125# ANSI - STANDARD
250# ANSI - AVAILABLE

DIMENSIONS IN INCHES (MM)		
S	X	Z
10.6 (269)	18.25 (464)	10.6 (269)

Removal clearance from end
of bracket: 24 Inches (610 mm)

STANDARD COUPLER

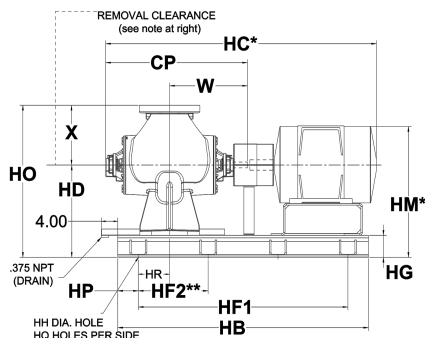

*Motor dimensions are approximate and vary by manufacturer and motor type.
**Distance to the next available hole.

MOTOR FRAME	DIMENSIONS - INCHES (mm) FOR STANDARD COUPLER															
	CP	HA	HB	HC*	HD	2HE	HF ₁	HF ₂ **	HG	HH	HM*	HO	HP	HQ	HR	W
284T/TS	37.9 (963)	31.4 (798)	73 (1854)	64.83 (1647)	27.25 (692)	29.52 (750)	63 (1600)	15.75 (400)	6.25 (159)	0.88 (22)	35.07 (891)	45.5 (1156)	5 (127)	5	9.13 (232)	20.82 (529)
286T/TS	37.9 (963)	31.4 (798)	73 (1854)	66.33 (1685)	27.25 (692)	29.52 (750)	63 (1600)	15.75 (400)	6.25 (159)	0.88 (22)	35.07 (891)	45.5 (1156)	5 (127)	5	9.13 (232)	20.82 (529)
324T/TS	37.9 (963)	31.4 (798)	73 (1854)	69.15 (1756)	27.25 (692)	29.52 (750)	63 (1600)	15.75 (400)	6.25 (159)	0.88 (22)	35.82 (910)	45.5 (1156)	5 (127)	5	9.13 (232)	20.82 (529)
326T/TS	37.9 (963)	31.4 (798)	73 (1854)	70.27 (1785)	27.25 (692)	29.52 (750)	63 (1600)	15.75 (400)	6.25 (159)	0.88 (22)	36.35 (923)	45.5 (1156)	5 (127)	5	9.13 (232)	20.82 (529)
364T/TS	37.9 (963)	31.4 (798)	73 (1854)	72.11 (1832)	27.25 (692)	29.52 (750)	63 (1600)	15.75 (400)	6.25 (159)	0.88 (22)	37.2 (945)	45.5 (1156)	5 (127)	5	9.13 (232)	20.82 (529)
365T/TS	37.9 (963)	31.4 (798)	73 (1854)	72.11 (1832)	27.25 (692)	29.52 (750)	63 (1600)	15.75 (400)	6.25 (159)	0.88 (22)	37.2 (945)	45.5 (1156)	5 (127)	5	9.13 (232)	20.82 (529)
404T/TS	37.9 (963)	31.4 (798)	73 (1854)	75.21 (1910)	27.25 (692)	29.52 (750)	63 (1600)	15.75 (400)	6.25 (159)	0.88 (22)	37.72 (958)	45.5 (1156)	5 (127)	5	9.13 (232)	20.82 (529)
405T/TS	37.9 (963)	31.4 (798)	73 (1854)	77.21 (1961)	27.25 (692)	29.52 (750)	63 (1600)	15.75 (400)	6.25 (159)	0.88 (22)	37.72 (958)	45.5 (1156)	5 (127)	5	9.13 (232)	20.82 (529)
444T/TS	37.9 (963)	31.4 (798)	84 (2134)	82.68 (2100)	27.25 (692)	29.52 (750)	74 (1880)	18.5 (470)	6.25 (159)	0.88 (22)	42.77 (1086)	45.5 (1156)	5 (127)	5	9.13 (232)	20.82 (529)
445T/TS	37.9 (963)	31.4 (798)	84 (2134)	84.28 (2141)	27.25 (692)	29.52 (750)	74 (1880)	18.5 (470)	6.25 (159)	0.88 (22)	42.77 (1086)	45.5 (1156)	5 (127)	5	9.13 (232)	20.82 (529)
447T/TS	37.9 (963)	31.4 (798)	84 (2134)	90.76 (2305)	27.25 (692)	29.52 (750)	74 (1880)	18.5 (470)	6.25 (159)	0.88 (22)	41.13 (1045)	45.5 (1156)	5 (127)	5	9.13 (232)	20.82 (529)
449T/TS	37.9 (963)	31.4 (798)	84 (2134)	91.46 (2323)	27.25 (692)	29.52 (750)	74 (1880)	18.5 (470)	6.25 (159)	0.88 (22)	41.13 (1045)	45.5 (1156)	5 (127)	5	9.13 (232)	20.82 (529)

Dimensions are subject to change. Not to be used for construction purposes unless certified.
Units may be built where foot/feet overhang the motor mounting platform. If overhang is unacceptable, consult factory for a custom submittal, quotation and/or lead time. A certified motor drawing will be required.

Xylem Inc.
8200 N. Austin Avenue
Morton Grove, IL 60053
Phone: (847)966-3700
Fax: (847)965-8379
www.bellgossett.com



JOB:	REPRESENTATIVE:	
UNIT TAG:	ORDER NO.	DATE:
ENGINEER:	SUBMITTED BY:	DATE:
CONTRACTOR:	APPROVED BY:	DATE:

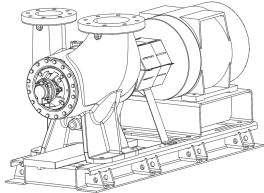

Model VSC 8x10x13 1/2 A Double Suction Split Case Pump



SPECIFICATIONS

FLOW _____ HEAD _____
 HP _____ RPM _____
 VOLTS _____
 CYCLE _____ PHASE _____
 ENCLOSURE _____
 APPROX. WEIGHT _____
 SPECIALS _____

STANDARD MATERIALS OF CONSTRUCTION

- Cast Iron Bronze Fitted
- Heavy Duty Maintenance Free Bearings
- Alignment Friendly Coupling
- Heavy Duty Groutless Baseplate
- ANSI/OSHA Coupling Guard
- ISO 1940-1:2003 Impeller Balance

OPTIONAL MATERIALS OF CONSTRUCTION

- Galvanized Drip Pan
- Spacer Coupling

TYPE OF SEAL AND WORKING PRESSURE

- Standard:** 175 PSIG (12 BAR) max. working pressure, flat face flanges, 125# ANSI flange drilling, Unitized mechanical seal, EPR/Carbon/Silicon Carbide, 175 PSIG (12 BAR) max. suction pressure, 0 to 300°F (-18 to 149°C)
- Optional:** 300 PSIG (20 BAR) max. working pressure, flat face flanges, 250# ANSI flange drilling, Unitized mechanical seal, EPR/Carbon/Silicon Carbide, 200 PSIG (13.7 BAR) max. suction pressure, 0 to 300°F (-18 to 149°C)
- Optional:** 300 PSIG (20 BAR) max. working pressure, flat face flanges, 250# ANSI flange drilling, balanced mechanical seal, EPR/Graphite loaded Silicon Carbide on Graphite loaded Silicon Carbide, 300 PSIG (20 BAR) max. suction pressure, 0 to 300°F (-18 to 149°C)

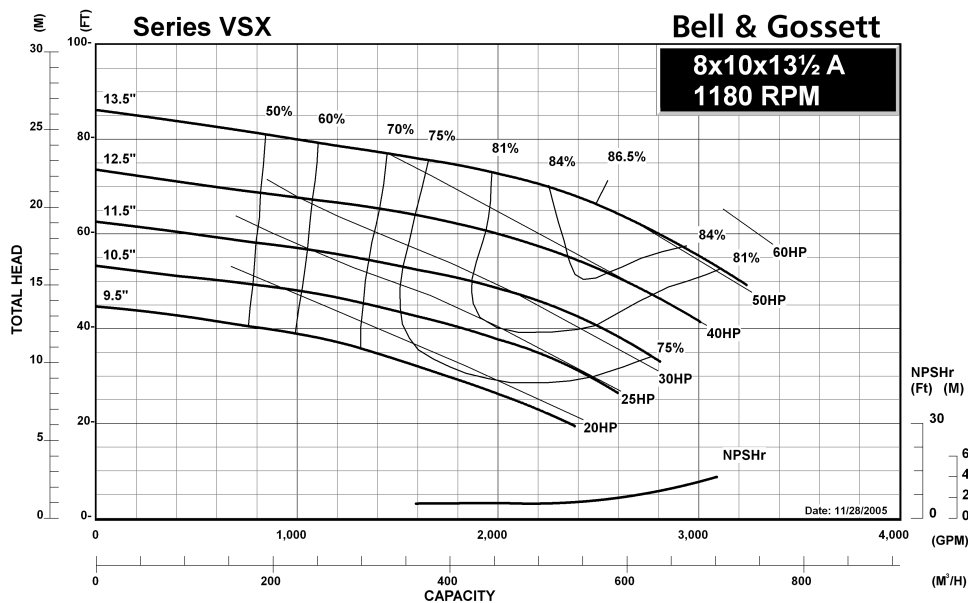

JOB:	REPRESENTATIVE:	
UNIT TAG:	ORDER NO.	DATE:
ENGINEER:	SUBMITTED BY:	DATE:
CONTRACTOR:	APPROVED BY:	DATE:

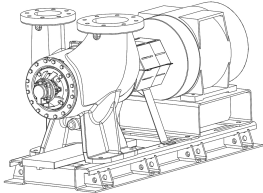

Model VSC

8x10x13 1/2 A

Double Suction Split Case Pump



SPECIFICATIONS

FLOW _____ HEAD _____

HP _____ RPM _____

VOLTS _____

CYCLE _____ PHASE _____

ENCLOSURE _____

APPROX. WEIGHT _____

SPECIALS _____

STANDARD MATERIALS OF CONSTRUCTION

- Cast Iron Bronze Fitted
- Heavy Duty Maintenance Free Bearings
- Alignment Friendly Coupling
- Heavy Duty Groutless Baseplate
- ANSI/OSHA Coupling Guard
- ISO 1940-1:2003 Impeller Balance

OPTIONAL MATERIALS OF CONSTRUCTION

- Galvanized Drip Pan
- Spacer Coupling

TYPE OF SEAL AND WORKING PRESSURE

- Standard:** 175 PSIG (12 BAR) max. working pressure, flat face flanges, 125# ANSI flange drilling, Unitized mechanical seal, EPR/Carbon/Silicon Carbide, 175 PSIG (12 BAR) max. suction pressure, 0 to 300°F (-18 to 149°C)
- Optional:** 300 PSIG (20 BAR) max. working pressure, flat face flanges, 250# ANSI flange drilling, Unitized mechanical seal, EPR/Carbon/Silicon Carbide, 200 PSIG (13.7 BAR) max. suction pressure, 0 to 300°F (-18 to 149°C)
- Optional:** 300 PSIG (20 BAR) max. working pressure, flat face flanges, 250# ANSI flange drilling, balanced mechanical seal, EPR/Graphite loaded Silicon Carbide on Graphite loaded Silicon Carbide, 300 PSIG (20 BAR) max. suction pressure, 0 to 300°F (-18 to 149°C)

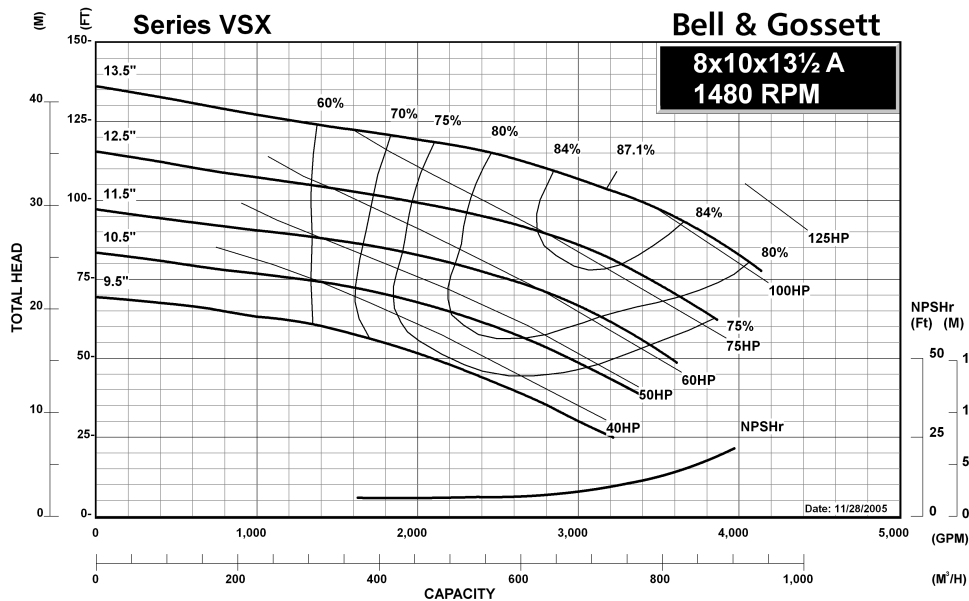

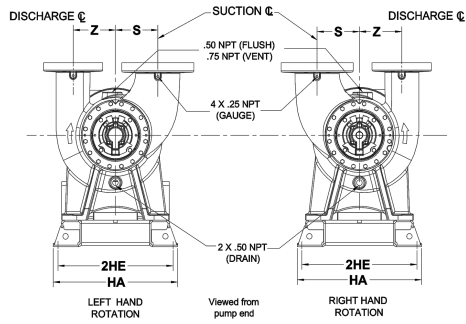

FLANGE DIMENSIONS IN INCHES (MM)			
	SIZE	THICKNESS	O.D.
Discharge	8"	1.81 (46)	14.75 (375)
Suction	10"	2.07 (52)	17.00 (432)

FLANGES ARE 125# ANSI - STANDARD
250# ANSI - AVAILABLE

DIMENSIONS IN INCHES (MM)		
S	X	Z
10.6 (269)	18.25 (464)	10.6 (269)

Removal clearance from end of bracket: 24 Inches (610 mm)

SPACER COUPLER

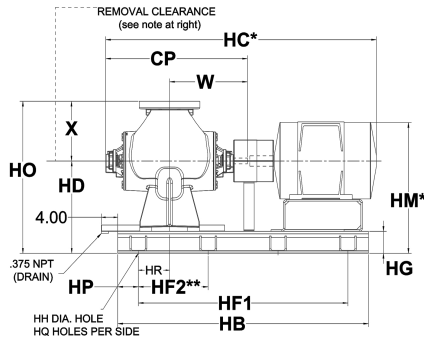

*Motor dimensions are approximate and vary by manufacturer and motor type.
**Distance to the next available hole.

MOTOR FRAME	DIMENSIONS - INCHES (mm) FOR SPACER COUPLER															
	CP	HA	HB	HC*	HD	2HE	HF ₁	HF ₂ **	HG	HH	HM*	HO	HP	HQ	HR	W
284T/TS	37.9 (963)	31.4 (798)	73 (1854)	74.08 (1882)	27.25 (692)	29.52 (750)	63 (1600)	15.75 (400)	6.25 (159)	0.88 (22)	35.07 (891)	45.5 (1156)	5 (127)	5	9.13 (232)	20.82 (529)
286T/TS	37.9 (963)	31.4 (798)	73 (1854)	75.58 (1920)	27.25 (692)	29.52 (750)	63 (1600)	15.75 (400)	6.25 (159)	0.88 (22)	35.07 (891)	45.5 (1156)	5 (127)	5	9.13 (232)	20.82 (529)
324T/TS	37.9 (963)	31.4 (798)	84 (2134)	78.4 (1991)	27.25 (692)	29.52 (750)	74 (1880)	18.5 (470)	6.25 (159)	0.88 (22)	35.82 (910)	45.5 (1156)	5 (127)	5	9.13 (232)	20.82 (529)
326T/TS	37.9 (963)	31.4 (798)	84 (2134)	79.52 (2020)	27.25 (692)	29.52 (750)	74 (1880)	18.5 (470)	6.25 (159)	0.88 (22)	36.35 (923)	45.5 (1156)	5 (127)	5	9.13 (232)	20.82 (529)
364T/TS	37.9 (963)	31.4 (798)	84 (2134)	81.359 (2067)	27.25 (692)	29.52 (750)	74 (1880)	18.5 (470)	6.25 (159)	0.88 (22)	37.2 (945)	45.5 (1156)	5 (127)	5	9.13 (232)	20.82 (529)
365T/TS	37.9 (963)	31.4 (798)	84 (2134)	81.35 (2067)	27.25 (692)	29.52 (750)	74 (1880)	18.5 (470)	6.25 (159)	0.88 (22)	37.2 (945)	45.5 (1156)	5 (127)	5	9.13 (232)	20.82 (529)
404T/TS	37.9 (963)	31.4 (798)	84 (2134)	83.96 (2133)	27.25 (692)	29.52 (750)	74 (1880)	18.5 (470)	6.25 (159)	0.88 (22)	37.72 (958)	45.5 (1156)	5 (127)	5	9.13 (232)	20.82 (529)
405T/TS	37.9 (963)	31.4 (798)	84 (2134)	85.96 (2183)	27.25 (692)	29.52 (750)	74 (1880)	18.5 (470)	6.25 (159)	0.88 (22)	37.72 (958)	45.5 (1156)	5 (127)	5	9.13 (232)	20.82 (529)
444T/TS	37.9 (963)	31.4 (798)	94 (2388)	91.42 (2322)	27.25 (692)	29.52 (750)	84 (2134)	16.8 (427)	6.25 (159)	0.88 (22)	42.77 (1086)	45.5 (1156)	5 (127)	6	9.13 (232)	20.82 (529)
445T/TS	37.9 (963)	31.4 (798)	94 (2388)	93.03 (2363)	27.25 (692)	29.52 (750)	84 (2134)	16.8 (427)	6.25 (159)	0.88 (22)	42.77 (1086)	45.5 (1156)	5 (127)	6	9.13 (232)	20.82 (529)
447T/TS	37.9 (963)	31.4 (798)	94 (2388)	99.51 (2528)	27.25 (692)	29.52 (750)	84 (2134)	16.8 (427)	6.25 (159)	0.88 (22)	41.13 (1045)	45.5 (1156)	5 (127)	6	9.13 (232)	20.82 (529)
449T/TS	37.9 (963)	31.4 (798)	94 (2388)	100.21 (2545)	27.25 (692)	29.52 (750)	84 (2134)	16.8 (427)	6.25 (159)	0.88 (22)	41.13 (1045)	45.5 (1156)	5 (127)	6	9.13 (232)	20.82 (529)

Dimensions are subject to change. Not to be used for construction purposes unless certified.
Units may be built where foot/feet overhang the motor mounting platform. If overhang is unacceptable, consult factory for a custom submittal, quotation and/or lead time. A certified motor drawing will be required.
These dimensions are valid when using the Woods Duraflex spacer coupling option. For dimensions on Falk SteelFlex coupling options, consult factory for a special submittal drawing.

