

<b>JOB:</b>	<b>REPRESENTATIVE:</b>	
<b>UNIT TAG:</b>	<b>ORDER NO.</b>	<b>DATE:</b>
<b>ENGINEER:</b>	<b>SUBMITTED BY:</b>	<b>DATE:</b>
<b>CONTRACTOR:</b>	<b>APPROVED BY:</b>	<b>DATE:</b>

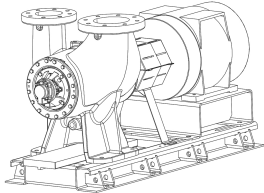

# Model VSC 10x12x13 1/2 A Double Suction Split Case Pump



**SPECIFICATIONS**

FLOW \_\_\_\_\_ HEAD \_\_\_\_\_  
 HP \_\_\_\_\_ RPM \_\_\_\_\_  
 VOLTS \_\_\_\_\_  
 CYCLE \_\_\_\_\_ PHASE \_\_\_\_\_  
 ENCLOSURE \_\_\_\_\_  
 APPROX. WEIGHT \_\_\_\_\_  
 SPECIALS \_\_\_\_\_  
 \_\_\_\_\_

**STANDARD MATERIALS OF CONSTRUCTION**

- Cast Iron Bronze Fitted
- Heavy Duty Maintenance Free Bearings
- Alignment Friendly Coupling
- Heavy Duty Groutless Baseplate
- ANSI/OSHA Coupling Guard
- ISO 1940-1:2003 Impeller Balance

**OPTIONAL MATERIALS OF CONSTRUCTION**

- Galvanized Drip Pan
- Spacer Coupling

**TYPE OF SEAL AND WORKING PRESSURE**

- Standard:** 175 PSIG (12 BAR) max. working pressure, flat face flanges, 125# ANSI flange drilling, Unitized mechanical seal, EPR/Carbon/Silicon Carbide, 160 PSIG (10.9 BAR) max. suction pressure, 0 to 300°F (-18 to 149°C)
- Optional:** 300 PSIG (20 BAR) max. working pressure, flat face flanges, 250# ANSI flange drilling, Unitized mechanical seal, EPR/Carbon/Silicon Carbide, 160 PSIG (10.9 BAR) max. suction pressure, 0 to 300°F (-18 to 149°C)
- Optional:** 300 PSIG (20 BAR) max. working pressure, flat face flanges, 250# ANSI flange drilling, balanced mechanical seal, EPR/Graphite loaded Silicon Carbide on Graphite loaded Silicon Carbide, 300 PSIG (20 BAR) max. suction pressure, 0 to 300°F (-18 to 149°C)

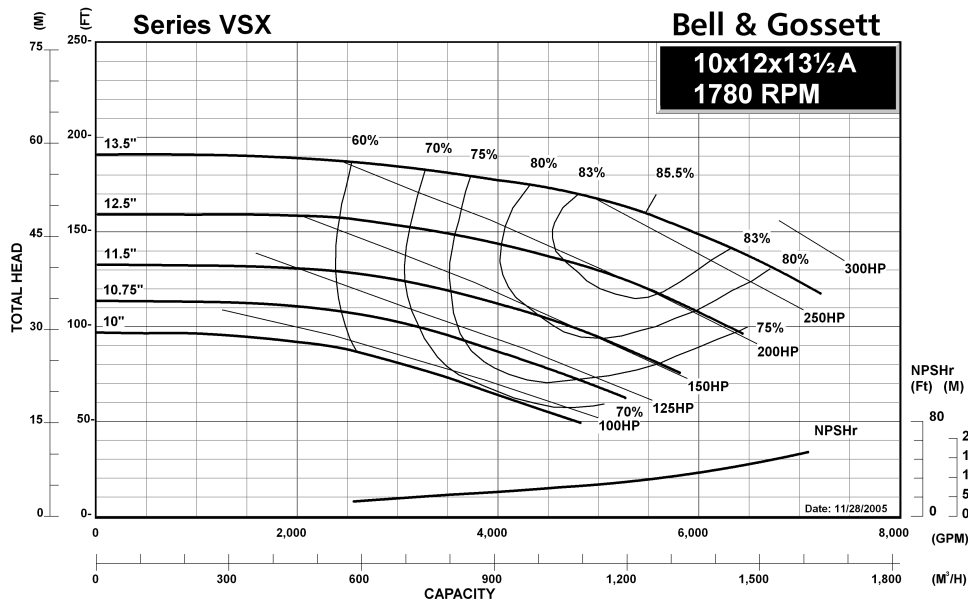

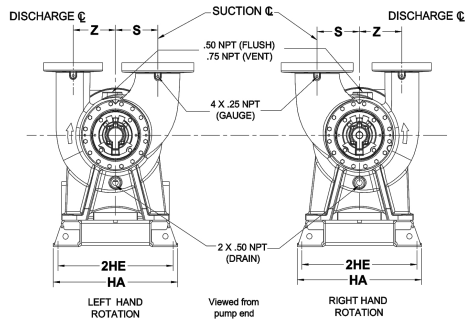

FLANGE DIMENSIONS IN INCHES (MM)			
	SIZE	THICKNESS	O.D.
Discharge	10"	2.13 (54)	17.00 (432)
Suction	12"	2.25 (57)	20.25 (521)

FLANGES ARE 125# ANSI - STANDARD  
250# ANSI - AVAILABLE

DIMENSIONS IN INCHES (MM)		
S	X	Z
11.375 (289)	19.5 (495)	11.375 (289)

Removal clearance from end  
of bracket: 26 Inches (660 mm)

**STANDARD COUPLER**

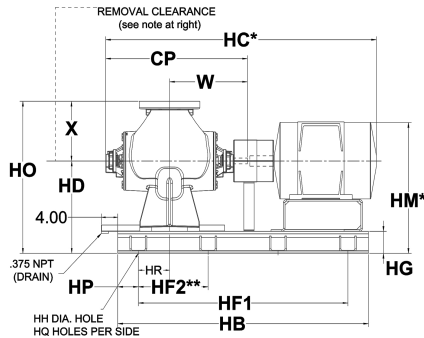

\*Motor dimensions are approximate and vary by manufacturer and motor type.  
\*\*Distance to the next available hole.

MOTOR FRAME	DIMENSIONS - INCHES (mm) FOR STANDARD COUPLER															
	CP	HA	HB	HC*	HD	2HE	HF <sub>1</sub>	HF <sub>2</sub> **	HG	HH	HM*	HO	HP	HQ	HR	W
324T/TS	37.9 (963)	31.4 (798)	73 (1854)	69.15 (1756)	28.75 (730)	29.52 (750)	63 (1600)	15.75 (400)	6.25 (159)	0.88 (22)	37.32 (948)	48.25 (1226)	5 (127)	5	9.13 (232)	20.82 (529)
326T/TS	37.9 (963)	31.4 (798)	73 (1854)	70.27 (1785)	28.75 (730)	29.52 (750)	63 (1600)	15.75 (400)	6.25 (159)	0.88 (22)	37.85 (961)	48.25 (1226)	5 (127)	5	9.13 (232)	20.82 (529)
364T/TS	37.9 (963)	31.4 (798)	73 (1854)	72.11 (1832)	28.75 (730)	29.52 (750)	63 (1600)	15.75 (400)	6.25 (159)	0.88 (22)	38.7 (983)	48.25 (1226)	5 (127)	5	9.13 (232)	20.82 (529)
365T/TS	37.9 (963)	31.4 (798)	73 (1854)	72.11 (1832)	28.75 (730)	29.52 (750)	63 (1600)	15.75 (400)	6.25 (159)	0.88 (22)	38.7 (983)	48.25 (1226)	5 (127)	5	9.13 (232)	20.82 (529)
404T/TS	37.9 (963)	31.4 (798)	73 (1854)	75.21 (1910)	28.75 (730)	29.52 (750)	63 (1600)	15.75 (400)	6.25 (159)	0.88 (22)	39.22 (996)	48.25 (1226)	5 (127)	5	9.13 (232)	20.82 (529)
405T/TS	37.9 (963)	31.4 (798)	73 (1854)	77.21 (1961)	28.75 (730)	29.52 (750)	63 (1600)	15.75 (400)	6.25 (159)	0.88 (22)	39.22 (996)	48.25 (1226)	5 (127)	5	9.13 (232)	20.82 (529)
444T/TS	37.9 (963)	31.4 (798)	84 (2134)	82.68 (2100)	28.75 (730)	29.52 (750)	74 (1880)	18.5 (470)	6.25 (159)	0.88 (22)	44.27 (1124)	48.25 (1226)	5 (127)	5	9.13 (232)	20.82 (529)
445T/TS	37.9 (963)	31.4 (798)	84 (2134)	84.28 (2141)	28.75 (730)	29.52 (750)	74 (1880)	18.5 (470)	6.25 (159)	0.88 (22)	44.27 (1124)	48.25 (1226)	5 (127)	5	9.13 (232)	20.82 (529)
447T/TS	37.9 (963)	31.4 (798)	84 (2134)	90.76 (2305)	28.75 (730)	29.52 (750)	74 (1880)	18.5 (470)	6.25 (159)	0.88 (22)	42.63 (1083)	48.25 (1226)	5 (127)	5	9.13 (232)	20.82 (529)
449T/TS	37.9 (963)	31.4 (798)	84 (2134)	91.46 (2323)	28.75 (730)	29.52 (750)	74 (1880)	18.5 (470)	6.25 (159)	0.88 (22)	42.63 (1083)	48.25 (1226)	5 (127)	5	9.13 (232)	20.82 (529)

Dimensions are subject to change. Not to be used for construction purposes unless certified.  
Units may be built where foot/feet overhang the motor mounting platform. If overhang is unacceptable, consult factory for a custom submittal, quotation and/or lead time. A certified motor drawing will be required.

Xylem Inc.  
8200 N. Austin Avenue  
Morton Grove, IL 60053  
Phone: (847)966-3700  
Fax: (847)965-8379  
www.bellgossett.com



<b>JOB:</b>	<b>REPRESENTATIVE:</b>	
<b>UNIT TAG:</b>	<b>ORDER NO.</b>	<b>DATE:</b>
<b>ENGINEER:</b>	<b>SUBMITTED BY:</b>	<b>DATE:</b>
<b>CONTRACTOR:</b>	<b>APPROVED BY:</b>	<b>DATE:</b>

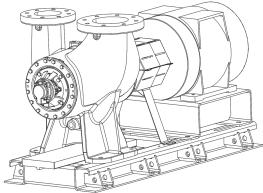

## Model VSC

# 10x12x13 1/2 A

### Double Suction Split Case Pump



**SPECIFICATIONS**

FLOW \_\_\_\_\_ HEAD \_\_\_\_\_

HP \_\_\_\_\_ RPM \_\_\_\_\_

VOLTS \_\_\_\_\_

CYCLE \_\_\_\_\_ PHASE \_\_\_\_\_

ENCLOSURE \_\_\_\_\_

APPROX. WEIGHT \_\_\_\_\_

SPECIALS \_\_\_\_\_

\_\_\_\_\_

**STANDARD MATERIALS OF CONSTRUCTION**

- Cast Iron Bronze Fitted
- Heavy Duty Maintenance Free Bearings
- Alignment Friendly Coupling
- Heavy Duty Groutless Baseplate
- ANSI/OSHA Coupling Guard
- ISO 1940-1:2003 Impeller Balance

**OPTIONAL MATERIALS OF CONSTRUCTION**

- Galvanized Drip Pan
- Spacer Coupling

**TYPE OF SEAL AND WORKING PRESSURE**

- Standard:** 175 PSIG (12 BAR) max. working pressure, flat face flanges, 125# ANSI flange drilling, Unitized mechanical seal, EPR/Carbon/Silicon Carbide, 160 PSIG (10.9 BAR) max. suction pressure, 0 to 300°F (-18 to 149°C)
- Optional:** 300 PSIG (20 BAR) max. working pressure, flat face flanges, 250# ANSI flange drilling, Unitized mechanical seal, EPR/Carbon/Silicon Carbide, 160 PSIG (10.9 BAR) max. suction pressure, 0 to 300°F (-18 to 149°C)
- Optional:** 300 PSIG (20 BAR) max. working pressure, flat face flanges, 250# ANSI flange drilling, balanced mechanical seal, EPR/Graphite loaded Silicon Carbide on Graphite loaded Silicon Carbide, 300 PSIG (20 BAR) max. suction pressure, 0 to 300°F (-18 to 149°C)

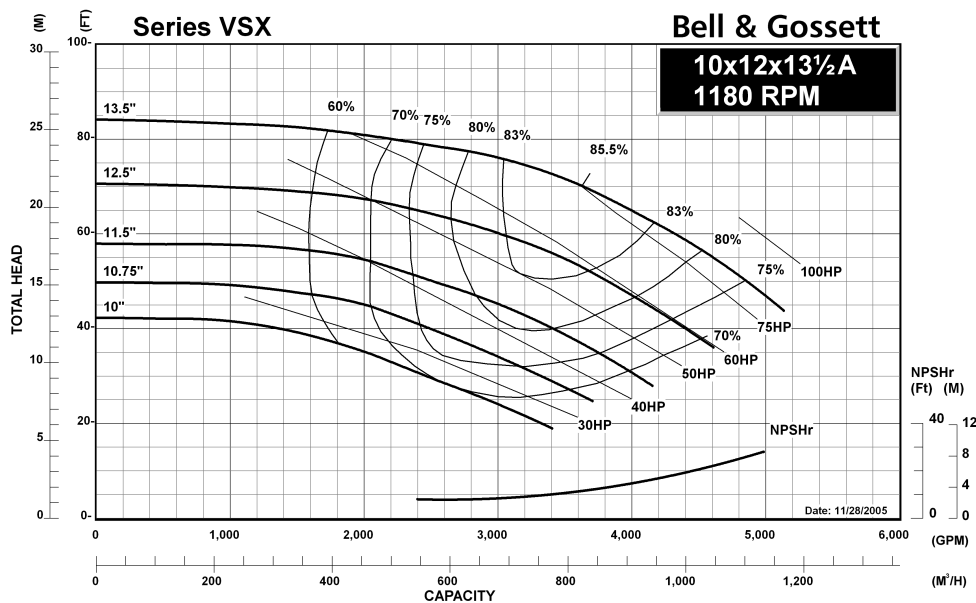

<b>JOB:</b>	<b>REPRESENTATIVE:</b>	
<b>UNIT TAG:</b>	<b>ORDER NO.</b>	<b>DATE:</b>
<b>ENGINEER:</b>	<b>SUBMITTED BY:</b>	<b>DATE:</b>
<b>CONTRACTOR:</b>	<b>APPROVED BY:</b>	<b>DATE:</b>

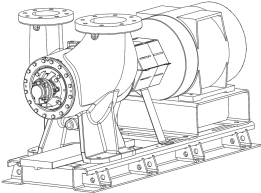

## Model VSC 10x12x13 1/2 A Double Suction Split Case Pump



**SPECIFICATIONS**

FLOW \_\_\_\_\_ HEAD \_\_\_\_\_  
 HP \_\_\_\_\_ RPM \_\_\_\_\_  
 VOLTS \_\_\_\_\_  
 CYCLE \_\_\_\_\_ PHASE \_\_\_\_\_  
 ENCLOSURE \_\_\_\_\_  
 APPROX. WEIGHT \_\_\_\_\_  
 SPECIALS \_\_\_\_\_  
 \_\_\_\_\_

**STANDARD MATERIALS OF CONSTRUCTION**

- Cast Iron Bronze Fitted
- Heavy Duty Maintenance Free Bearings
- Alignment Friendly Coupling
- Heavy Duty Groutless Baseplate
- ANSI/OSHA Coupling Guard
- ISO 1940-1:2003 Impeller Balance

**OPTIONAL MATERIALS OF CONSTRUCTION**

- Galvanized Drip Pan
- Spacer Coupling

**TYPE OF SEAL AND WORKING PRESSURE**

- Standard:** 175 PSIG (12 BAR) max. working pressure, flat face flanges, 125# ANSI flange drilling, Unitized mechanical seal, EPR/Carbon/Silicon Carbide, 160 PSIG (10.9 BAR) max. suction pressure, 0 to 300°F (-18 to 149°C)
- Optional:** 300 PSIG (20 BAR) max. working pressure, flat face flanges, 250# ANSI flange drilling, Unitized mechanical seal, EPR/Carbon/Silicon Carbide, 160 PSIG (10.9 BAR) max. suction pressure, 0 to 300°F (-18 to 149°C)
- Optional:** 300 PSIG (20 BAR) max. working pressure, flat face flanges, 250# ANSI flange drilling, balanced mechanical seal, EPR/Graphite loaded Silicon Carbide on Graphite loaded Silicon Carbide, 300 PSIG (20 BAR) max. suction pressure, 0 to 300°F (-18 to 149°C)

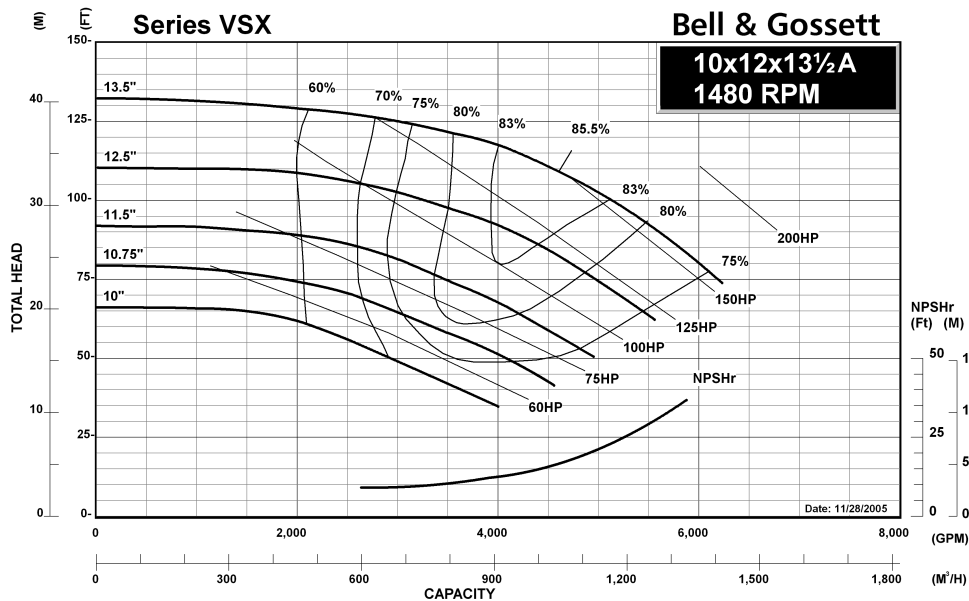

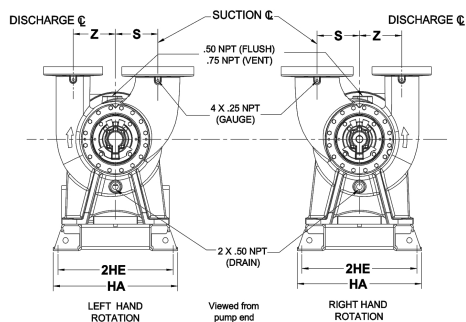

FLANGE DIMENSIONS IN INCHES (MM)			
	SIZE	THICKNESS	O.D.
Discharge	10"	2.13 (54)	17.00 (432)
Suction	12"	2.25 (57)	20.25 (521)

FLANGES ARE 125# ANSI - STANDARD  
250# ANSI - AVAILABLE

DIMENSIONS IN INCHES (MM)		
S	X	Z
11.375 (289)	19.5 (495)	11.375 (289)

Removal clearance from end  
of bracket: 26 Inches (660 mm)

### SPACER COUPLER

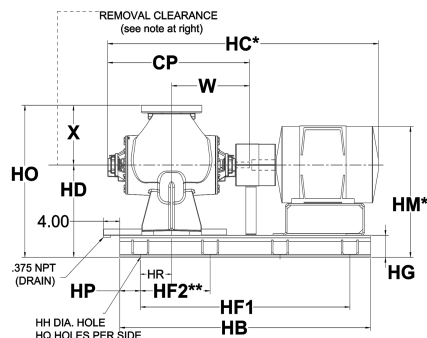

\*Motor dimensions are approximate and vary by manufacturer and motor type.

\*\*Distance to the next available hole.

MOTOR FRAME	DIMENSIONS - INCHES (mm) FOR SPACER COUPLER															
	CP	HA	HB	HC*	HD	2HE	HF <sub>1</sub>	HF <sub>2</sub> **	HG	HH	HM*	HO	HP	HQ	HR	W
324T/TS	37.9 (963)	31.4 (798)	84 (2134)	78.4 (1991)	28.75 (730)	29.52 (750)	74 (1880)	18.5 (470)	6.25 (159)	0.88 (22)	37.32 (948)	48.25 (1226)	5 (127)	5	9.13 (232)	20.82 (529)
326T/TS	37.9 (963)	31.4 (798)	84 (2134)	79.52 (2020)	28.75 (730)	29.52 (750)	74 (1880)	18.5 (470)	6.25 (159)	0.88 (22)	37.85 (961)	48.25 (1226)	5 (127)	5	9.13 (232)	20.82 (529)
364T/TS	37.9 (963)	31.4 (798)	84 (2134)	81.36 (2067)	28.75 (730)	29.52 (750)	74 (1880)	18.5 (470)	6.25 (159)	0.88 (22)	38.7 (983)	48.25 (1226)	5 (127)	5	9.13 (232)	20.82 (529)
365T/TS	37.9 (963)	31.4 (798)	84 (2134)	81.36 (2067)	28.75 (730)	29.52 (750)	74 (1880)	18.5 (470)	6.25 (159)	0.88 (22)	38.7 (983)	48.25 (1226)	5 (127)	5	9.13 (232)	20.82 (529)
404T/TS	37.9 (963)	31.4 (798)	84 (2134)	83.96 (2133)	28.75 (730)	29.52 (750)	74 (1880)	18.5 (470)	6.25 (159)	0.88 (22)	39.22 (996)	48.25 (1226)	5 (127)	5	9.13 (232)	20.82 (529)
405T/TS	37.9 (963)	31.4 (798)	84 (2134)	85.96 (2183)	28.75 (730)	29.52 (750)	74 (1880)	18.5 (470)	6.25 (159)	0.88 (22)	39.22 (996)	48.25 (1226)	5 (127)	5	9.13 (232)	20.82 (529)
444T/TS	37.9 (963)	31.4 (798)	94 (2388)	91.43 (2322)	28.75 (730)	29.52 (750)	84 (2134)	16.8 (427)	6.25 (159)	0.88 (22)	44.27 (1124)	48.25 (1226)	5 (127)	6	9.13 (232)	20.82 (529)
445T/TS	37.9 (963)	31.4 (798)	94 (2388)	93.03 (2363)	28.75 (730)	29.52 (750)	84 (2134)	16.8 (427)	6.25 (159)	0.88 (22)	44.27 (1124)	48.25 (1226)	5 (127)	6	9.13 (232)	20.82 (529)
447T/TS	37.9 (963)	31.4 (798)	94 (2388)	99.51 (2528)	28.75 (730)	29.52 (750)	84 (2134)	16.8 (427)	6.25 (159)	0.88 (22)	42.63 (1083)	48.25 (1226)	5 (127)	6	9.13 (232)	20.82 (529)
449T/TS	37.9 (963)	31.4 (798)	94 (2388)	100.21 (2545)	28.75 (730)	29.52 (750)	84 (2134)	16.8 (427)	6.25 (159)	0.88 (22)	42.63 (1083)	48.25 (1226)	5 (127)	6	9.13 (232)	20.82 (529)

Dimensions are subject to change. Not to be used for construction purposes unless certified.

Units may be built where foot/feet overhang the motor mounting platform. If overhang is unacceptable, consult factory for a custom submittal, quotation and/or lead time. A certified motor drawing will be required.

These dimensions are valid when using the Woods Duraflex spacer coupling option. For dimensions on Falk SteelFlex coupling options, consult factory for a special submittal drawing.

Xylem Inc.  
8200 N. Austin Avenue  
Morton Grove, IL 60053  
Phone: (847)966-3700  
Fax: (847)965-8379  
www.bellgossett.com

