

JOB:	REPRESENTATIVE:	
UNIT TAG:	ORDER NO.	DATE:
ENGINEER:	SUBMITTED BY:	DATE:
CONTRACTOR:	APPROVED BY:	DATE:

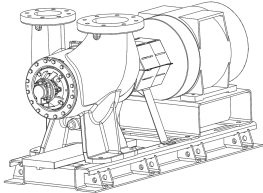

Model VSC 4x6x17 1/2 A Double Suction Split Case Pump



SPECIFICATIONS

FLOW _____ HEAD _____
 HP _____ RPM _____
 VOLTS _____
 CYCLE _____ PHASE _____
 ENCLOSURE _____
 APPROX. WEIGHT _____
 SPECIALS _____

STANDARD MATERIALS OF CONSTRUCTION

- Cast Iron Bronze Fitted
- Heavy Duty Maintenance Free Bearings
- Alignment Friendly Coupling
- Heavy Duty Groutless Baseplate
- ANSI/OSHA Coupling Guard
- ISO 1940-1:2003 Impeller Balance

OPTIONAL MATERIALS OF CONSTRUCTION

- Galvanized Drip Pan
- Spacer Coupling

TYPE OF SEAL AND WORKING PRESSURE

- Standard:** 175 PSIG (12 BAR) max. working pressure, flat face flanges, 125# ANSI flange drilling, Unitized mechanical seal, EPR/Carbon/Silicon Carbide, 175 PSIG (12 BAR) max. suction pressure, 0 to 300°F (-18 to 149°C)
- Optional:** 300 PSIG (20 BAR) max. working pressure, flat face flanges, 250# ANSI flange drilling, Unitized mechanical seal, EPR/Carbon/Silicon Carbide, 200 PSIG (13.7 BAR) max. suction pressure, 0 to 300°F (-18 to 149°C)
- Optional:** 300 PSIG (20 BAR) max. working pressure, flat face flanges, 250# ANSI flange drilling, balanced mechanical seal, EPR/Graphite loaded Silicon Carbide on Graphite loaded Silicon Carbide, 300 PSIG (20 BAR) max. suction pressure, 0 to 300°F (-18 to 149°C)

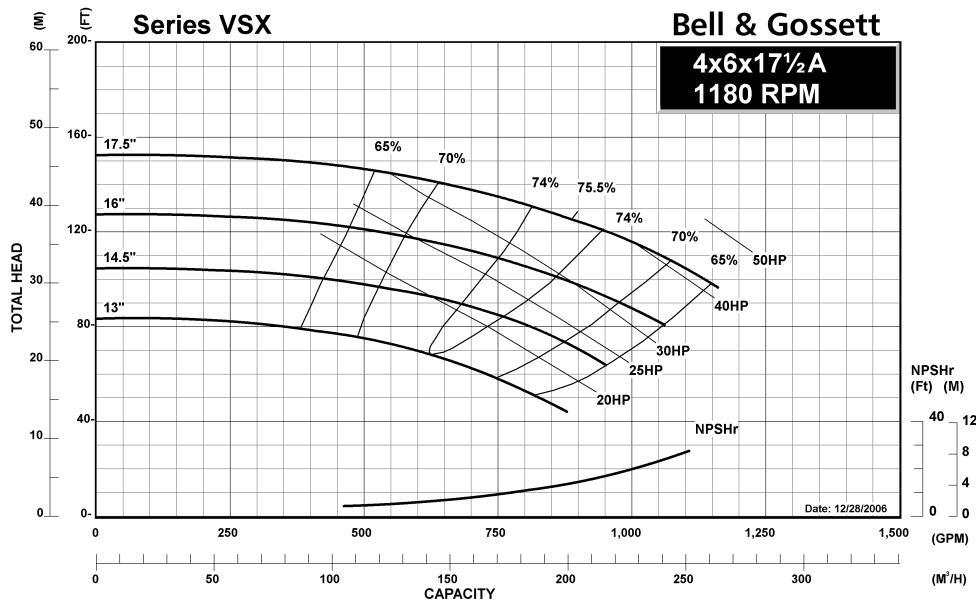

JOB:	REPRESENTATIVE:	
UNIT TAG:	ORDER NO.	DATE:
ENGINEER:	SUBMITTED BY:	DATE:
CONTRACTOR:	APPROVED BY:	DATE:

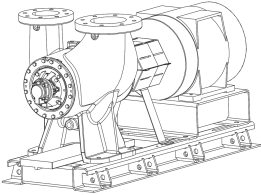

Model VSC

4x6x17 1/2 A

Double Suction Split Case Pump



SPECIFICATIONS

FLOW _____ HEAD _____

HP _____ RPM _____

VOLTS _____

CYCLE _____ PHASE _____

ENCLOSURE _____

APPROX. WEIGHT _____

SPECIALS _____

STANDARD MATERIALS OF CONSTRUCTION

- Cast Iron Bronze Fitted
- Heavy Duty Maintenance Free Bearings
- Alignment Friendly Coupling
- Heavy Duty Groutless Baseplate
- ANSI/OSHA Coupling Guard
- ISO 1940-1:2003 Impeller Balance

OPTIONAL MATERIALS OF CONSTRUCTION

- Galvanized Drip Pan
- Spacer Coupling

TYPE OF SEAL AND WORKING PRESSURE

- Standard:** 175 PSIG (12 BAR) max. working pressure, flat face flanges, 125# ANSI flange drilling, Unitized mechanical seal, EPR/Carbon/Silicon Carbide, 175 PSIG (12 BAR) max. suction pressure, 0 to 300°F (-18 to 149°C)
- Optional:** 300 PSIG (20 BAR) max. working pressure, flat face flanges, 250# ANSI flange drilling, Unitized mechanical seal, EPR/Carbon/Silicon Carbide, 200 PSIG (13.7 BAR) max. suction pressure, 0 to 300°F (-18 to 149°C)
- Optional:** 300 PSIG (20 BAR) max. working pressure, flat face flanges, 250# ANSI flange drilling, balanced mechanical seal, EPR/Graphite loaded Silicon Carbide on Graphite loaded Silicon Carbide, 300 PSIG (20 BAR) max. suction pressure, 0 to 300°F (-18 to 149°C)

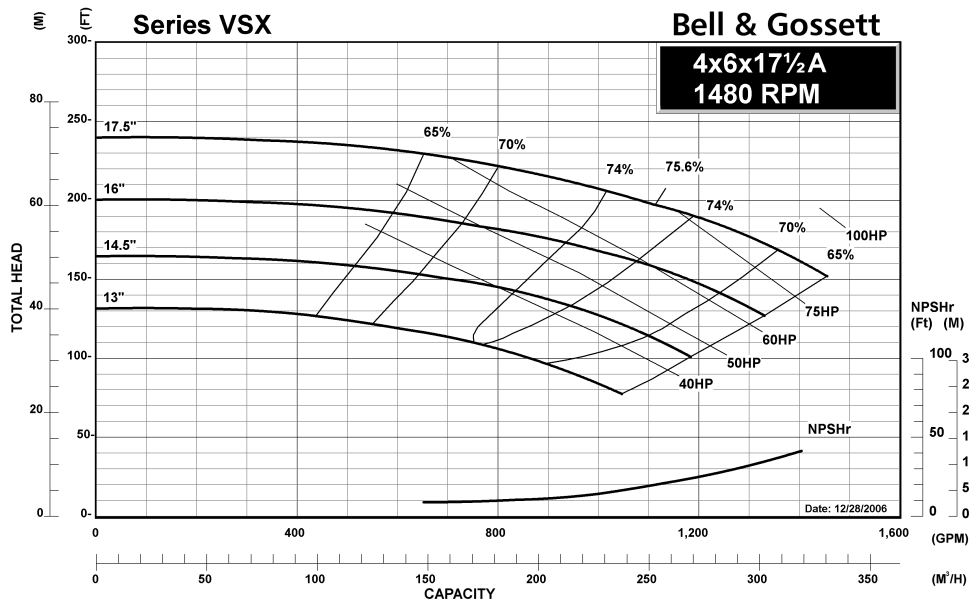

JOB:	REPRESENTATIVE:	
UNIT TAG:	ORDER NO.	DATE:
ENGINEER:	SUBMITTED BY:	DATE:
CONTRACTOR:	APPROVED BY:	DATE:

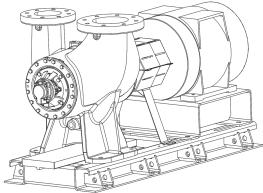

Model VSC 4x6x17 1/2 A Double Suction Split Case Pump



SPECIFICATIONS

FLOW _____ HEAD _____
 HP _____ RPM _____
 VOLTS _____
 CYCLE _____ PHASE _____
 ENCLOSURE _____
 APPROX. WEIGHT _____
 SPECIALS _____

STANDARD MATERIALS OF CONSTRUCTION

- Cast Iron Bronze Fitted
- Heavy Duty Maintenance Free Bearings
- Alignment Friendly Coupling
- Heavy Duty Groutless Baseplate
- ANSI/OSHA Coupling Guard
- ISO 1940-1:2003 Impeller Balance

OPTIONAL MATERIALS OF CONSTRUCTION

- Galvanized Drip Pan
- Spacer Coupling

TYPE OF SEAL AND WORKING PRESSURE

- Standard:** 175 PSIG (12 BAR) max. working pressure, flat face flanges, 125# ANSI flange drilling, Unitized mechanical seal, EPR/Carbon/Silicon Carbide, 175 PSIG (12 BAR) max. suction pressure, 0 to 300°F (-18 to 149°C)
- Optional:** 300 PSIG (20 BAR) max. working pressure, flat face flanges, 250# ANSI flange drilling, Unitized mechanical seal, EPR/Carbon/Silicon Carbide, 200 PSIG (13.7 BAR) max. suction pressure, 0 to 300°F (-18 to 149°C)
- Optional:** 300 PSIG (20 BAR) max. working pressure, flat face flanges, 250# ANSI flange drilling, balanced mechanical seal, EPR/Graphite loaded Silicon Carbide on Graphite loaded Silicon Carbide, 300 PSIG (20 BAR) max. suction pressure, 0 to 300°F (-18 to 149°C)

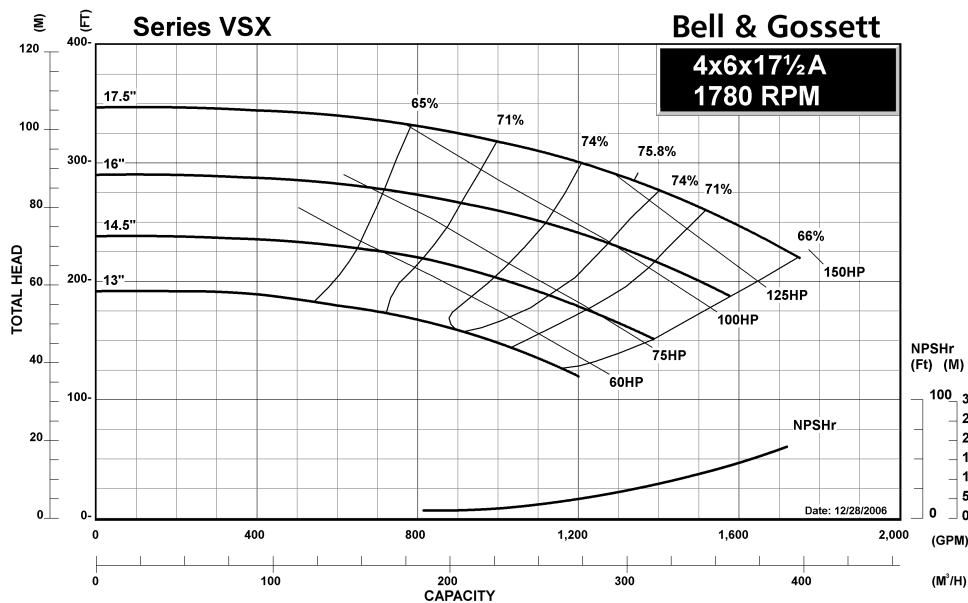

Model VSC 4x6x17½A Centrifugal Pump Submittal

B-865.21E

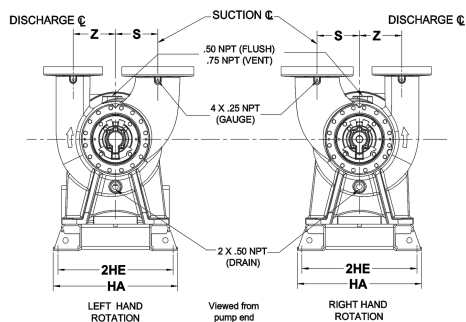

FLANGE DIMENSIONS IN INCHES (MM)			
	SIZE	THICKNESS	O.D.
Discharge	4"	1.50 (38)	10 (254)
Suction	6"	1.63 (41)	12.13 (308)

FLANGES ARE DRILLED 125# ANSI - STANDARD
250# ANSI - AVAILABLE

DIMENSIONS IN INCHES (MM)		
S	X	Z
9.75 (248)	18 (457)	9.75 (248)

Removal clearance from end of bracket: 23 Inches (584 mm)

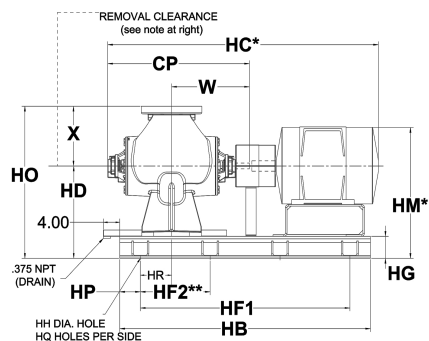

STANDARD COUPLER

*Motor dimensions are approximate and vary by manufacturer and motor type.

**Distance to the next available hole.

MOTOR FRAME	DIMENSIONS - INCHES (mm) FOR PUMPS WITH STANDARD COUPLERS															
	CP	HA	HB	HC* MAX.	HD	2HE	HF ₁	HF ₂ **	HG	HH	HM* MAX.	HO	HP	HQ	HR	W
254T	29.42 (747)	25.4 (645)	61 (1549)	53.44 (1357)	23.25 (591)	23.52 (597)	51 (1295)	17 (432)	5.25 (133)	0.88 (22)	31.07 (789)	41.25 (1048)	5 (127)	4	7.63 (194)	16.40 (417)
256T	29.42 (747)	25.4 (645)	61 (1549)	55.19 (1402)	23.25 (591)	23.52 (597)	51 (1295)	17 (432)	5.25 (133)	0.88 (22)	31.07 (789)	41.25 (1048)	5 (127)	4	7.63 (194)	16.40 (417)
284T/TS	29.42 (747)	25.4 (645)	61 (1549)	56.363 (1431)	23.25 (591)	23.52 (597)	51 (1295)	17 (432)	5.25 (133)	0.88 (22)	31.07 (789)	41.25 (1048)	5 (127)	4	7.63 (194)	16.40 (417)
286T/TS	29.42 (747)	25.4 (645)	61 (1549)	57.849 (1469)	23.25 (591)	23.52 (597)	51 (1295)	17 (432)	5.25 (133)	0.88 (22)	31.07 (789)	41.25 (1048)	5 (127)	4	7.63 (194)	16.40 (417)
324T/TS	29.42 (747)	25.4 (645)	61 (1549)	60.67 (1541)	23.25 (591)	23.52 (597)	51 (1295)	17 (432)	5.25 (133)	0.88 (22)	31.82 (808)	41.25 (1048)	5 (127)	4	7.63 (194)	16.40 (417)
326T/TS	29.42 (747)	25.4 (645)	61 (1549)	61.79 (1569)	23.25 (591)	23.52 (597)	51 (1295)	17 (432)	5.25 (133)	0.88 (22)	32.35 (822)	41.25 (1048)	5 (127)	4	7.63 (194)	16.40 (417)
364T/TS	29.42 (747)	25.4 (645)	61 (1549)	63.629 (1616)	23.25 (591)	23.52 (597)	51 (1295)	17 (432)	5.25 (133)	0.88 (22)	33.2 (843)	41.25 (1048)	5 (127)	4	7.63 (194)	16.40 (417)
365T/TS	29.42 (747)	25.4 (645)	61 (1549)	63.629 (1616)	23.25 (591)	23.52 (597)	51 (1295)	17 (432)	5.25 (133)	0.88 (22)	33.2 (843)	41.25 (1048)	5 (127)	4	7.63 (194)	16.40 (417)
404T/TS	29.42 (747)	25.4 (645)	70 (1778)	66.73 (1695)	23.25 (591)	23.52 (597)	60 (1524)	15 (381)	5.25 (133)	0.88 (22)	33.72 (856)	41.25 (1048)	5 (127)	5	7.62 (194)	16.40 (417)
405T/TS	29.42 (747)	25.4 (645)	70 (1778)	68.73 (1746)	23.25 (591)	23.52 (597)	60 (1524)	15 (381)	5.25 (133)	0.88 (22)	33.72 (856)	41.25 (1048)	5 (127)	5	7.62 (194)	16.40 (417)
444T/TS	29.42 (747)	25.4 (645)	70 (1778)	74.196 (1885)	23.25 (591)	23.52 (597)	60 (1524)	15 (381)	5.25 (133)	0.88 (22)	38.77 (985)	41.25 (1048)	5 (127)	5	7.62 (194)	16.40 (417)
445T/TS	29.42 (747)	25.4 (645)	70 (1778)	75.8 (1925)	23.25 (591)	23.52 (597)	60 (1524)	15 (381)	5.25 (133)	0.88 (22)	38.77 (985)	41.25 (1048)	5 (127)	5	7.62 (194)	16.40 (417)

Dimensions are subject to change. Not to be used for construction purposes unless certified.

Units may be built where foot/feet overhang the motor mounting platform. If overhang is unacceptable, consult factory for a custom submittal, quotation and/or lead time. A certified motor drawing will be required.

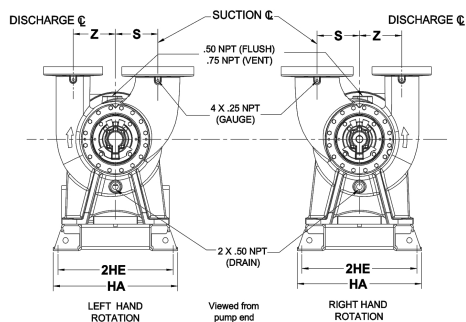

FLANGE DIMENSIONS IN INCHES (MM)			
	SIZE	THICKNESS	O.D.
Discharge	4"	1.50 (38)	10 (254)
Suction	6"	1.63 (41)	12.13 (308)

FLANGES ARE DRILLED 125# ANSI - STANDARD
250# ANSI - AVAILABLE

DIMENSIONS IN INCHES (MM)		
S	X	Z
9.75 (248)	18 (457)	9.75 (248)

Removal clearance from end of bracket: 23 Inches (584 mm)

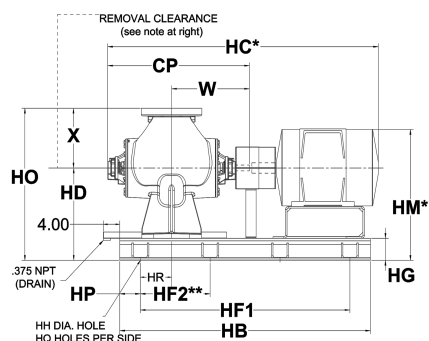

SPACER COUPLER

*Motor dimensions are approximate and vary by manufacturer and motor type.

** Distance to the next available hole.

MOTOR FRAME	DIMENSIONS - INCHES (mm) FOR PUMPS WITH SPACER COUPLERS															
	CP	HA	HB	HC* MAX.	HD	2HE	HF ₁	HF ₂ **	HG	HH	HM* MAX.	HO	HP	HQ	HR	W
254T	29.42 (747)	25.4 (645)	70 (1778)	62.69 (1592)	23.25 (591)	23.52 (597)	60 (1524)	15 (381)	5.25 (133)	0.88 (22)	31.07 (789)	41.25 (1048)	5 (127)	5	7.62 (194)	16.40 (417)
256T	29.42 (747)	25.4 (645)	70 (1778)	64.44 (1637)	23.25 (591)	23.52 (597)	60 (1524)	15 (381)	5.25 (133)	0.88 (22)	31.07 (789)	41.25 (1048)	5 (127)	5	7.62 (194)	16.40 (417)
284T/TS	29.42 (747)	25.4 (645)	70 (1778)	65.603 (1666)	23.25 (591)	23.52 (597)	60 (1524)	15 (381)	5.25 (133)	0.88 (22)	31.07 (789)	41.25 (1048)	5 (127)	5	7.62 (194)	16.40 (417)
286T/TS	29.42 (747)	25.4 (645)	70 (1778)	67.099 (1704)	23.25 (591)	23.52 (597)	60 (1524)	15 (381)	5.25 (133)	0.88 (22)	31.07 (789)	41.25 (1048)	5 (127)	5	7.62 (194)	16.40 (417)
324T/TS	29.42 (747)	25.4 (645)	70 (1778)	69.92 (1776)	23.25 (591)	23.52 (597)	60 (1524)	15 (381)	5.25 (133)	0.88 (22)	31.82 (808)	41.25 (1048)	5 (127)	5	7.62 (194)	16.40 (417)
326T/TS	29.42 (747)	25.4 (645)	70 (1778)	71.04 (1804)	23.25 (591)	23.52 (597)	60 (1524)	15 (381)	5.25 (133)	0.88 (22)	32.35 (822)	41.25 (1048)	5 (127)	5	7.62 (194)	16.40 (417)
364T/TS	29.42 (747)	25.4 (645)	80 (2032)	72.879 (1851)	23.25 (591)	23.52 (597)	72 (1829)	18 (457)	5.25 (133)	0.88 (22)	33.2 (843)	41.25 (1048)	4 (102)	5	8.63 (219)	16.40 (417)
365T/TS	29.42 (747)	25.4 (645)	80 (2032)	72.879 (1851)	23.25 (591)	23.52 (597)	72 (1829)	18 (457)	5.25 (133)	0.88 (22)	33.2 (843)	41.25 (1048)	4 (102)	5	8.63 (219)	16.40 (417)
404T/TS	29.42 (747)	25.4 (645)	80 (2032)	75.48 (1917)	23.25 (591)	23.52 (597)	72 (1829)	18 (457)	5.25 (133)	0.88 (22)	33.72 (856)	41.25 (1048)	4 (102)	5	8.63 (219)	16.40 (417)
405T/TS	29.42 (747)	25.4 (645)	80 (2032)	77.48 (1968)	23.25 (591)	23.52 (597)	72 (1829)	18 (457)	5.25 (133)	0.88 (22)	33.72 (856)	41.25 (1048)	4 (102)	5	8.63 (219)	16.40 (417)
444T/TS	29.42 (747)	25.4 (645)	80 (2032)	82.948 (2107)	23.25 (591)	23.52 (597)	72 (1829)	18 (457)	5.25 (133)	0.88 (22)	38.77 (985)	41.25 (1048)	4 (102)	5	8.63 (219)	16.40 (417)
445T/TS	29.42 (747)	25.4 (645)	80 (2032)	84.55 (2148)	23.25 (591)	23.52 (597)	72 (1829)	18 (457)	5.25 (133)	0.88 (22)	38.77 (985)	41.25 (1048)	4 (102)	5	8.63 (219)	16.40 (417)

Dimensions are subject to change. Not to be used for construction purposes unless certified.

Units may be built where foot/feet overhang the motor mounting platform. If overhang is unacceptable, consult factory for a custom submittal, quotation and/or lead time. A certified motor drawing will be required.

These dimensions are valid when using the Woods Duraflex spacer coupling option. For dimensions on Faulk SteelFlex coupling options, consult factory for a special submittal drawing.

Bell & Gossett is a trademark of Xylem Inc. or one of its subsidiaries.
© 2013 Xylem Inc.