

<b>JOB:</b>	<b>REPRESENTATIVE:</b>	
<b>UNIT TAG:</b>	<b>ORDER NO.</b>	<b>DATE:</b>
<b>ENGINEER:</b>	<b>SUBMITTED BY:</b>	<b>DATE:</b>
<b>CONTRACTOR:</b>	<b>APPROVED BY:</b>	<b>DATE:</b>

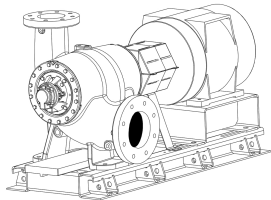

# Model VSCS 10x12x22A Double Suction Split Case Pump



**SPECIFICATIONS**

FLOW \_\_\_\_\_ HEAD \_\_\_\_\_  
 HP \_\_\_\_\_ RPM \_\_\_\_\_  
 VOLTS \_\_\_\_\_  
 CYCLE \_\_\_\_\_ PHASE \_\_\_\_\_  
 ENCLOSURE \_\_\_\_\_  
 APPROX. WEIGHT \_\_\_\_\_  
 SPECIALS \_\_\_\_\_  
 \_\_\_\_\_

**STANDARD MATERIALS OF CONSTRUCTION**

- Cast Iron Bronze Fitted
- Heavy Duty Maintenance Free Bearings
- Alignment Friendly Coupling
- Heavy Duty Groutless Baseplate
- ANSI/OSHA Coupling Guard
- ISO 1940-1:2003 Impeller Balance

**OPTIONAL MATERIALS OF CONSTRUCTION**

- Galvanized Drip Pan
- Spacer Coupling

**TYPE OF SEAL AND WORKING PRESSURE**

- Standard:** 175 PSIG (12 BAR) max. working pressure, flat face flanges, 125# ANSI flange drilling, Unitized mechanical seal, EPR/Carbon/Silicon Carbide, 125 PSIG (8.5 BAR) max. suction pressure, 0 to 300°F (-18 to 149°C)
- Optional:** 300 PSIG (20 BAR) max. working pressure, flat face flanges, 250# ANSI flange drilling, Unitized mechanical seal, EPR/Carbon/Silicon Carbide, 125 PSIG (8.5 BAR) max. suction pressure, 0 to 300°F (-18 to 149°C)
- Optional:** 300 PSIG (20 BAR) max. working pressure, flat face flanges, 250# ANSI flange drilling, balanced mechanical seal, EPR/Graphite loaded Silicon Carbide on Graphite loaded Silicon Carbide, 300 PSIG (20 BAR) max. suction pressure, 0 to 300°F (-18 to 149°C)

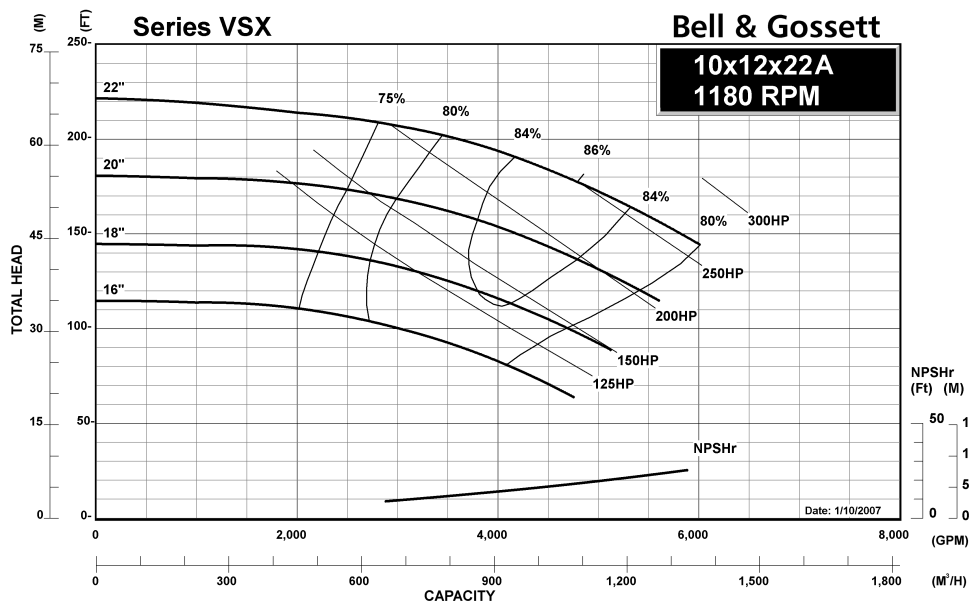

<b>JOB:</b>	<b>REPRESENTATIVE:</b>	
<b>UNIT TAG:</b>	<b>ORDER NO.</b>	<b>DATE:</b>
<b>ENGINEER:</b>	<b>SUBMITTED BY:</b>	<b>DATE:</b>
<b>CONTRACTOR:</b>	<b>APPROVED BY:</b>	<b>DATE:</b>

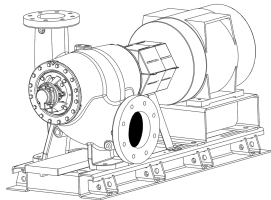

# Model VSCS 10x12x22A Double Suction Split Case Pump



**SPECIFICATIONS**

FLOW \_\_\_\_\_ HEAD \_\_\_\_\_  
 HP \_\_\_\_\_ RPM \_\_\_\_\_  
 VOLTS \_\_\_\_\_  
 CYCLE \_\_\_\_\_ PHASE \_\_\_\_\_  
 ENCLOSURE \_\_\_\_\_  
 APPROX. WEIGHT \_\_\_\_\_  
 SPECIALS \_\_\_\_\_  
 \_\_\_\_\_

**STANDARD MATERIALS OF CONSTRUCTION**

- Cast Iron Bronze Fitted
- Heavy Duty Maintenance Free Bearings
- Alignment Friendly Coupling
- Heavy Duty Groutless Baseplate
- ANSI/OSHA Coupling Guard
- ISO 1940-1:2003 Impeller Balance

**OPTIONAL MATERIALS OF CONSTRUCTION**

- Galvanized Drip Pan
- Spacer Coupling

**TYPE OF SEAL AND WORKING PRESSURE**

- Standard:** 175 PSIG (12 BAR) max. working pressure, flat face flanges, 125# ANSI flange drilling, Unitized mechanical seal, EPR/Carbon/Silicon Carbide, 125 PSIG (8.5 BAR) max. suction pressure, 0 to 300°F (-18 to 149°C)
- Optional:** 300 PSIG (20 BAR) max. working pressure, flat face flanges, 250# ANSI flange drilling, Unitized mechanical seal, EPR/Carbon/Silicon Carbide, 125 PSIG (8.5 BAR) max. suction pressure, 0 to 300°F (-18 to 149°C)
- Optional:** 300 PSIG (20 BAR) max. working pressure, flat face flanges, 250# ANSI flange drilling, balanced mechanical seal, EPR/Graphite loaded Silicon Carbide on Graphite loaded Silicon Carbide, 300 PSIG (20 BAR) max. suction pressure, 0 to 300°F (-18 to 149°C)

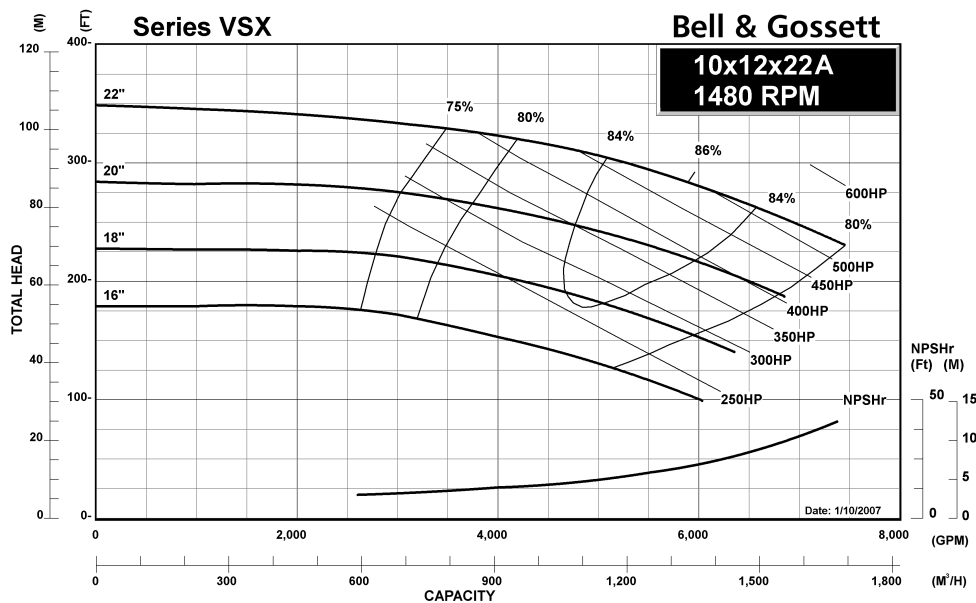

<b>JOB:</b>	<b>REPRESENTATIVE:</b>	
<b>UNIT TAG:</b>	<b>ORDER NO.</b>	<b>DATE:</b>
<b>ENGINEER:</b>	<b>SUBMITTED BY:</b>	<b>DATE:</b>
<b>CONTRACTOR:</b>	<b>APPROVED BY:</b>	<b>DATE:</b>

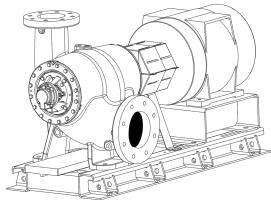

# Model VSCS 10x12x22A Double Suction Split Case Pump



**SPECIFICATIONS**

FLOW \_\_\_\_\_ HEAD \_\_\_\_\_  
 HP \_\_\_\_\_ RPM \_\_\_\_\_  
 VOLTS \_\_\_\_\_  
 CYCLE \_\_\_\_\_ PHASE \_\_\_\_\_  
 ENCLOSURE \_\_\_\_\_  
 APPROX. WEIGHT \_\_\_\_\_  
 SPECIALS \_\_\_\_\_  
 \_\_\_\_\_

**STANDARD MATERIALS OF CONSTRUCTION**

- Cast Iron Bronze Fitted
- Heavy Duty Maintenance Free Bearings
- Alignment Friendly Coupling
- Heavy Duty Groutless Baseplate
- ANSI/OSHA Coupling Guard
- ISO 1940-1:2003 Impeller Balance

**OPTIONAL MATERIALS OF CONSTRUCTION**

- Galvanized Drip Pan
- Spacer Coupling

**TYPE OF SEAL AND WORKING PRESSURE**

- Standard:** 175 PSIG (12 BAR) max. working pressure, flat face flanges, 125# ANSI flange drilling, Unitized mechanical seal, EPR/Carbon/Silicon Carbide, 125 PSIG (8.5 BAR) max. suction pressure, 0 to 300°F (-18 to 149°C)
- Optional:** 300 PSIG (20 BAR) max. working pressure, flat face flanges, 250# ANSI flange drilling, Unitized mechanical seal, EPR/Carbon/Silicon Carbide, 125 PSIG (8.5 BAR) max. suction pressure, 0 to 300°F (-18 to 149°C)
- Optional:** 300 PSIG (20 BAR) max. working pressure, flat face flanges, 250# ANSI flange drilling, balanced mechanical seal, EPR/Graphite loaded Silicon Carbide on Graphite loaded Silicon Carbide, 300 PSIG (20 BAR) max. suction pressure, 0 to 300°F (-18 to 149°C)

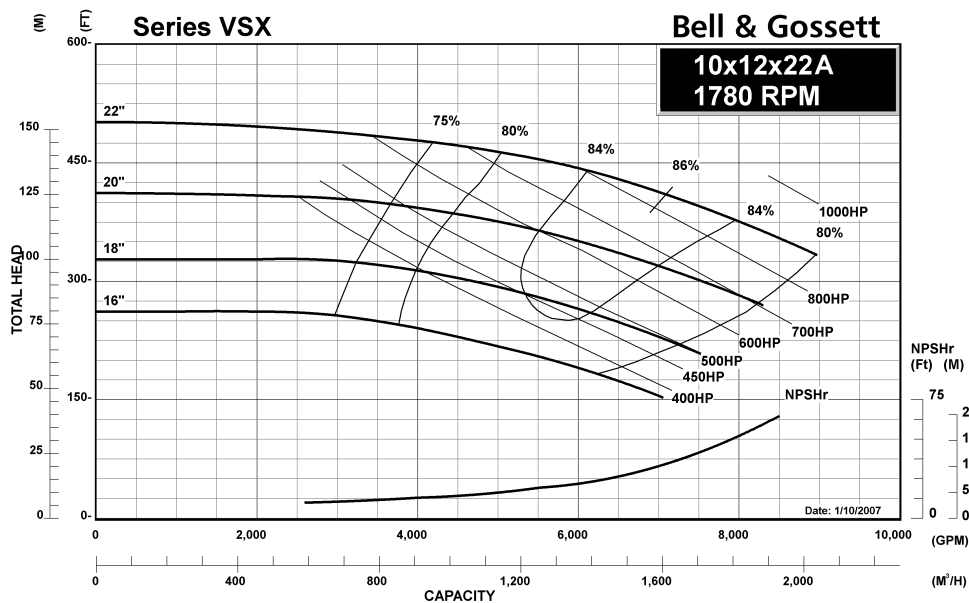

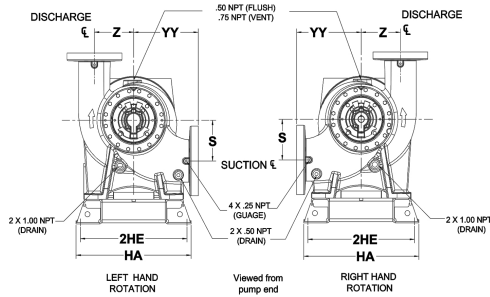

FLANGE DIMENSIONS IN INCHES (MM)			
	SIZE	THICKNESS	O.D.
Discharge	10"	2.06 (52)	17 (432)
Suction	12"	2.19 (56)	20.25 (514)

FLANGES ARE DRILLED 125# ANSI - STANDARD  
250# ANSI - AVAILABLE

DIMENSIONS IN INCHES (MM)			
S	X	YY	Z
14.56 (370)	24.75 (629)	24.75 (629)	14.56 (370)

Removal clearance from end  
of bracket: 26 Inches (660 mm)

STANDARD COUPLER

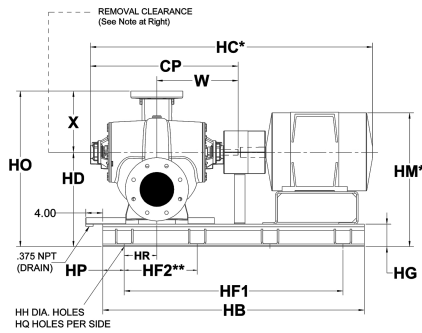

\*Motor dimensions are approximate and vary by manufacturer and motor type.  
\*\*Distance to the next available hole.

MOTOR FRAME	DIMENSIONS - INCHES (mm) FOR PUMPS WITH STANDARD COUPLER															
	CP	HA	HB	HC* MAX.	HD	2HE	HF <sub>1</sub>	HF <sub>2</sub> **	HG	HH	HM* MAX.	HO	HP	HQ	HR	W
404T/TS	41.4 (1052)	41 (1041)	91 (2311)	78.71 (1999)	33 (838)	39.12 (994)	81 (2057)	20.25 (514)	7 (178)	1.13 (29)	47 (1194)	57.75 (1467)	5 (127)	5	14.75 (375)	23.21 (590)
405T/TS	41.4 (1052)	41 (1041)	91 (2311)	80.71 (2050)	33 (838)	39.12 (994)	81 (2057)	20.25 (514)	7 (178)	1.13 (29)	47 (1194)	57.75 (1467)	5 (127)	5	14.75 (375)	23.21 (590)
444T/TS	41.4 (1052)	41 (1041)	91 (2311)	86.176 (2189)	33 (838)	39.12 (994)	81 (2057)	20.25 (514)	7 (178)	1.13 (29)	48.52 (1232)	57.75 (1467)	5 (127)	5	14.75 (375)	23.21 (590)
445T/TS	41.4 (1052)	41 (1041)	91 (2311)	87.78 (2230)	33 (838)	39.12 (994)	81 (2057)	20.25 (514)	7 (178)	1.13 (29)	48.52 (1232)	57.75 (1467)	5 (127)	5	14.75 (375)	23.21 (590)
447T/TS	41.4 (1052)	41 (1041)	96 (2438)	94.26 (2394)	33 (838)	39.12 (994)	86 (2184)	17.2 (437)	7 (178)	1.13 (29)	46.88 (1191)	57.75 (1467)	5 (127)	6	14.75 (375)	23.21 (590)
449T/TS	41.4 (1052)	41 (1041)	96 (2438)	94.96 (2412)	33 (838)	39.12 (994)	86 (2184)	17.2 (437)	7 (178)	1.13 (29)	46.88 (1191)	57.75 (1467)	5 (127)	6	14.75 (375)	23.21 (590)
5008S/MS † ‡	41.4 (1052)	41 (1041)	96 (2438)	90.78 (2306)	33 (838)	39.12 (994)	86 (2184)	17.2 (437)	7 (178)	1.13 (29)	47.5 (1207)	57.75 (1467)	5 (127)	6	14.75 (375)	23.21 (590)
5010S/MS † ‡	41.4 (1052)	41 (1041)	108 (2743)	97.28 (2471)	35.38 (899)	38 (965)	98 (2489)	24.5 (622)	9.38 (238)	1.375 (35)	49.88 (1267)	60.13 (1527)	5 (127)	5	14.75 (375)	23.21 (590)
5012S/MS † ‡	41.4 (1052)	41 (1041)	108 (2743)	105.28 (2674)	35.38 (899)	38 (965)	98 (2489)	24.5 (622)	9.38 (238)	1.375 (35)	49.88 (1267)	60.13 (1527)	5 (127)	5	14.75 (375)	23.21 (590)
5807S † ‡	41.4 (1052)	41 (1041)	106.50 (2705)	101.15 (2569)	35.38 (899)	38 (965)	96.50 (2451)	24.125 (613)	9.38 (238)	1.375 (35)	50.94 (1294)	60.13 (1527)	5 (127)	5	14.75 (375)	23.21 (590)
5809S † ‡	41.4 (1052)	41 (1041)	106.50 (2705)	108.15 (2747)	35.38 (899)	38 (965)	96.50 (2451)	24.125 (613)	9.38 (238)	1.375 (35)	50.94 (1294)	60.13 (1527)	5 (127)	5	14.75 (375)	23.21 (590)
5811S † ‡	41.4 (1052)	41 (1041)	106.50 (2705)	116.15 (2950)	35.38 (899)	38 (965)	96.50 (2451)	24.125 (613)	9.38 (238)	1.375 (35)	50.94 (1294)	60.13 (1527)	5 (127)	5	14.75 (375)	23.21 (590)
5811M+ † ‡	41.4 (1052)	41 (1041)	106.5 (2705)	128.09 (3253)	35.38 (899)	38 (965)	96.52 (2452)	24.13 (613)	9.38 (238)	1.375 (35)	103.51 (2629)	60.13 (1527)	5 (127)	5	14.75 (375)	23.21 (590)

Dimensions are subject to change. Not to be used for construction purposes unless certified.  
Units may be built where foot/feet overhang the motor mounting platform. If overhang is unacceptable, consult factory for a custom submittal, quotation and/or lead time. A certified motor drawing will be required.  
† For all customer supplied motors above 449 NEMA frame, a certified motor drawing must be supplied by the customer at the time of order entry.  
‡ Submittal dimensions for motor frames above 449 NEMA are specific to ODP U.S. Electric Motors Only.



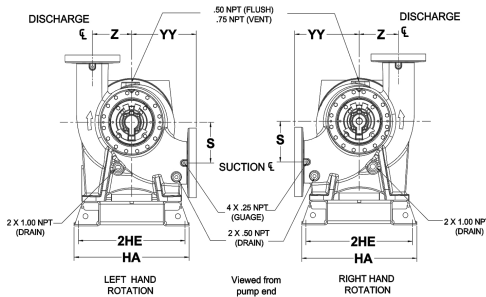

FLANGE DIMENSIONS IN INCHES (MM)			
	SIZE	THICKNESS	O.D.
Discharge	10"	2.06 (52)	17 (432)
Suction	12"	2.19 (56)	20.25 (514)

FLANGES ARE DRILLED 125# ANSI - STANDARD  
250# ANSI - AVAILABLE

DIMENSIONS IN INCHES (MM)			
S	X	YY	Z
14.56 (370)	24.75 (629)	24.75 (629)	14.56 (370)

Removal clearance from end  
of bracket: 26 Inches (660 mm)

SPACER COUPLER

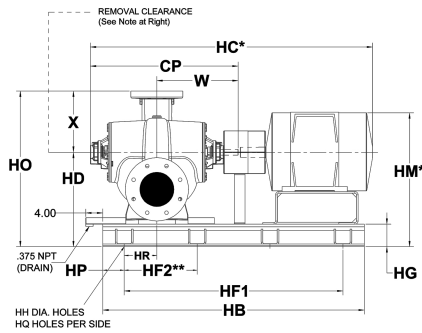

\*Motor dimensions are approximate and vary by manufacturer and motor type.  
\*\*Distance to the next available hole.

MOTOR FRAME	DIMENSIONS - INCHES (mm) FOR PUMPS WITH SPACER COUPLERS															
	CP	HA	HB	HC* MAX.	HD	2HE	HF <sub>1</sub>	HF <sub>2</sub> **	HG	HH	HM* MAX.	HO	HP	HQ	HR	W
404T/TS	41.4 (1052)	41 (1041)	105 (2667)	87.46 (2221)	33 (838)	39.12 (994)	95 (2413)	19 (483)	7 (178)	1.13 (29)	47 (1194)	57.75 (1467)	5 (127)	6	14.75 (375)	23.21 (590)
405T/TS	41.4 (1052)	41 (1041)	105 (2667)	89.46 (2272)	33 (838)	39.12 (994)	95 (2413)	19 (483)	7 (178)	1.13 (29)	47 (1194)	57.75 (1467)	5 (127)	6	14.75 (375)	23.21 (590)
444T/TS	41.4 (1052)	41 (1041)	105 (2667)	94.926 (2411)	33 (838)	39.12 (994)	95 (2413)	19 (483)	7 (178)	1.13 (29)	48.52 (1232)	57.75 (1467)	5 (127)	6	14.75 (375)	23.21 (590)
445T/TS	41.4 (1052)	41 (1041)	105 (2667)	96.53 (2452)	33 (838)	39.12 (994)	95 (2413)	19 (483)	7 (178)	1.13 (29)	48.52 (1232)	57.75 (1467)	5 (127)	6	14.75 (375)	23.21 (590)
447T/TS	41.4 (1052)	41 (1041)	105 (2667)	103.01 (2616)	33 (838)	39.12 (994)	95 (2413)	19 (483)	7 (178)	1.13 (29)	46.88 (1191)	57.75 (1467)	5 (127)	6	14.75 (375)	23.21 (590)
449T/TS	41.4 (1052)	41 (1041)	105 (2667)	103.71 (2634)	33 (838)	39.12 (994)	95 (2413)	19 (483)	7 (178)	1.13 (29)	46.88 (1191)	57.75 (1467)	5 (127)	6	14.75 (375)	23.21 (590)
5008S/MS † ‡	41.4 (1052)	41 (1041)	105 (2667)	99.53 (2528)	33 (838)	39.12 (994)	95 (2413)	19 (483)	7 (178)	1.13 (29)	47.5 (1207)	57.75 (1467)	5 (127)	6	14.75 (375)	23.21 (590)
5010S/MS † ‡	41.4 (1052)	41 (1041)	124 (3150)	106.03 (2693)	35.38 (899)	38 (965)	114 (2896)	28.5 (724)	9.38 (238)	1.375 (35)	49.88 (1267)	60.13 (1527)	5 (127)	5	14.75 (375)	23.21 (590)
5012S/MS † ‡	41.4 (1052)	41 (1041)	124 (3150)	114.03 (2896)	35.38 (899)	38 (965)	114 (2896)	28.5 (724)	9.38 (238)	1.375 (35)	49.88 (1267)	60.13 (1527)	5 (127)	5	14.75 (375)	23.21 (590)
5807S † ‡	41.4 (1052)	41 (1041)	110.50 (2807)	109.65 (2785)	35.38 (899)	38 (965)	100.52 (2553)	25.13 (638)	9.38 (238)	1.375 (35)	50.94 (1294)	60.13 (1527)	5 (127)	5	14.75 (375)	23.21 (590)
5809S † ‡	41.4 (1052)	41 (1041)	110.50 (2807)	116.65 (2963)	35.38 (899)	38 (965)	100.52 (2553)	25.13 (638)	9.38 (238)	1.375 (35)	50.94 (1294)	60.13 (1527)	5 (127)	5	14.75 (375)	23.21 (590)
5811S † ‡	41.4 (1052)	41 (1041)	110.50 (2807)	124.65 (3166)	35.38 (899)	38 (965)	100.52 (2553)	25.13 (638)	9.38 (238)	1.375 (35)	50.94 (1294)	60.13 (1527)	5 (127)	5	14.75 (375)	23.21 (590)
5811M+ † ‡	41.4 (1052)	41 (1041)	110.50 (2807)	136.59 (3469)	35.38 (899)	38 (965)	100.52 (2553)	25.13 (638)	9.38 (238)	1.375 (35)	103.51 (2629)	60.13 (1527)	5 (127)	5	14.75 (375)	23.21 (590)

Dimensions are subject to change. Not to be used for construction purposes unless certified.  
Units may be built where foot/feet overhang the motor mounting platform. If overhang is unacceptable, consult factory for a custom submittal, quotation and/or lead time. A certified motor drawing will be required.  
These dimensions are valid when using the Woods Duraflex spacer coupling option. For dimensions on Faulk SteelFlex coupling options, consult factory for a special submittal drawing.  
† For all customer supplied motors above 449 NEMA frame, a certified motor drawing must be supplied by the customer at the time of order entry.  
‡ Submittal dimensions for motor frames above 449 NEMA are specific to ODP U.S. Electric Motors Only.

Xylem Inc.  
8200 N. Austin Avenue  
Morton Grove, IL 60053  
Phone: (847)966-3700  
Fax: (847)965-8379  
[www.bellgossett.com](http://www.bellgossett.com)



Bell & Gossett is a trademark of Xylem Inc. or one of its subsidiaries.  
© 2013 Xylem Inc.