

JOB: UNIT TAG: ENGINEER: CONTRACTOR:	REPRESENTATIVE: ORDER NO. SUBMITTED BY: APPROVED BY:	DATE: DATE: DATE:
---	---	--

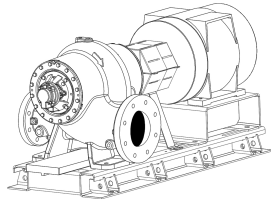

Model VSH

12x14x17 1/2 A

Double Suction Split Case Pump



SPECIFICATIONS

FLOW _____ HEAD _____
 HP _____ RPM _____
 VOLTS _____
 CYCLE _____ PHASE _____
 ENCLOSURE _____
 APPROX. WEIGHT _____
 SPECIALS _____

STANDARD MATERIALS OF CONSTRUCTION

- Cast Iron Bronze Fitted
- Heavy Duty Maintenance Free Bearings
- Alignment Friendly Coupling
- Heavy Duty Groutless Baseplate
- ANSI/OSHA Coupling Guard
- ISO 1940-1:2003 Impeller Balance

OPTIONAL MATERIALS OF CONSTRUCTION

- Galvanized Drip Pan
- Spacer Coupling

TYPE OF SEAL AND WORKING PRESSURE

- Standard:** 175 PSIG (12 BAR) max. working pressure, flat face flanges, 125# ANSI flange drilling, Unitized mechanical seal, EPR/Carbon/Silicon Carbide, 125 PSIG (8.5 BAR) max. suction pressure, 0 to 300°F (-18 to 149°C)
- Optional:** 300 PSIG (20 BAR) max. working pressure, flat face flanges, 250# ANSI flange drilling, Unitized mechanical seal, EPR/Carbon/Silicon Carbide, 125 PSIG (8.5 BAR) max. suction pressure, 0 to 300°F (-18 to 149°C)
- Optional:** 300 PSIG (20 BAR) max. working pressure, flat face flanges, 250# ANSI flange drilling, balanced mechanical seal, EPR/Graphite loaded Silicon Carbide on Graphite loaded Silicon Carbide, 300 PSIG (20 BAR) max. suction pressure, 0 to 300°F (-18 to 149°C)

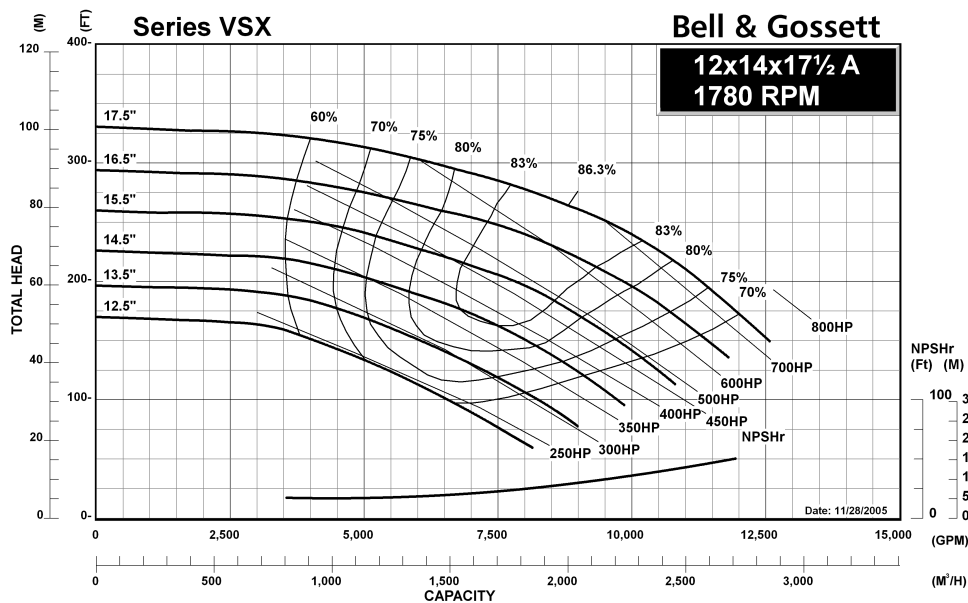

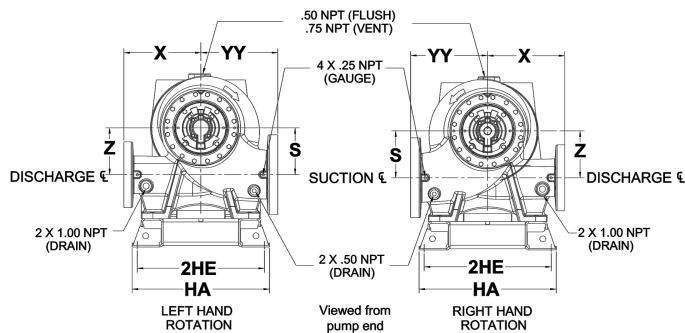

FLANGE DIMENSIONS IN INCHES (MM)			
	SIZE	THICKNESS	O.D.
Discharge	12"	2.25 (56)	20.25 (514)
Suction	14"	2.38 (60)	22.38 (568)

FLANGES ARE 125# ANSI - STANDARD
250# ANSI - AVAILABLE

DIMENSIONS IN INCHES (MM)				
S	VH	X	YY	Z
14.4 (366)	16.5 (419)	24 (610)	24 (610)	14.4 (366)

Removal clearance from end
of bracket: 34 Inches (864 mm)

STANDARD COUPLER

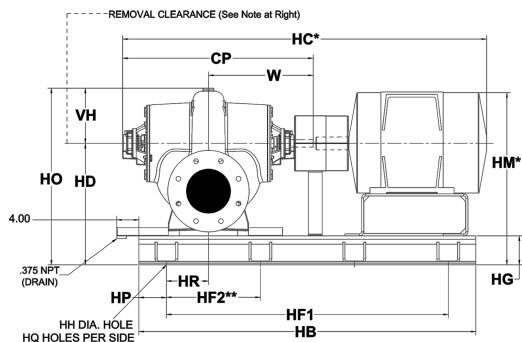

*Motor dimensions are approximate and vary by manufacturer and motor type.
**Distance to the next available hole.

MOTOR FRAME	DIMENSIONS - INCHES (mm) FOR STANDARD COUPLER															
	CP	HA	HB	HC*	HD	2HE	HF ₁	HF ₂ **	HG	HH	HM*	HO	HP	HQ	HR	W
404T/TS	50.25 (1276)	41 (1041)	91 (2311)	87.56 (2224)	33 (838)	39.12 (994)	81 (2057)	20.25 (514)	7 (178)	1.13 (29)	43.47 (1104)	49.5 (1257)	5 (127)	5	14.75 (375)	27.63 (702)
405T/TS	50.25 (1276)	41 (1041)	91 (2311)	89.56 (2275)	33 (838)	39.12 (994)	81 (2057)	20.25 (514)	7 (178)	1.13 (29)	43.47 (1104)	49.5 (1257)	5 (127)	5	14.75 (375)	27.63 (702)
444T/TS	50.25 (1276)	41 (1041)	91 (2311)	95.026 (2414)	33 (838)	39.12 (994)	81 (2057)	20.25 (514)	7 (178)	1.13 (29)	48.52 (1232)	49.5 (1257)	5 (127)	5	14.75 (375)	27.63 (702)
445T/TS	50.25 (1276)	41 (1041)	91 (2311)	96.63 (2454)	33 (838)	39.12 (994)	81 (2057)	20.25 (514)	7 (178)	1.13 (29)	48.52 (1232)	49.5 (1257)	5 (127)	5	14.75 (375)	27.63 (702)
447T/TS	50.25 (1276)	41 (1041)	96 (2438)	103.11 (2619)	33 (838)	39.12 (994)	86 (2184)	17.2 (437)	7 (178)	1.13 (29)	46.88 (1191)	49.5 (1257)	5 (127)	6	14.75 (375)	27.63 (702)
449T/TS	50.25 (1276)	41 (1041)	96 (2438)	103.81 (2637)	33 (838)	39.12 (994)	86 (2184)	17.2 (432)	7 (178)	1.13 (29)	46.88 (1191)	49.5 (1257)	5 (127)	6	14.75 (375)	27.63 (702)
5008S/MS	50.25 (1276)	41 (1041)	96 (2438)	99.63 (2531)	33 (838)	39.12 (994)	86 (2184)	17.2 (432)	7 (178)	1.13 (29)	47.5 (1207)	49.5 (1257)	5 (127)	6	14.75 (375)	27.63 (702)
5010S/MS	50.25 (1276)	41 (1041)	108 (2743)	105.96 (2691)	35.38 (899)	38 (965)	98 (2489)	24.5 (622)	9.38 (238)	1.375 (35)	49.88 (1267)	51.88 (1318)	5 (127)	5	14.75 (375)	27.63 (702)
5012S/MS	50.25 (1276)	41 (1041)	108 (2743)	113.96 (2895)	35.38 (899)	38 (965)	98 (2489)	24.5 (622)	9.38 (238)	1.375 (35)	49.88 (1267)	51.88 (1318)	5 (127)	5	14.75 (375)	27.63 (702)
5807S	50.25 (1276)	41 (1041)	110.50 (2807)	109.66 (2785)	35.38 (899)	38 (965)	100.52 (2553)	25.125 (638)	9.38 (238)	1.375 (35)	50.94 (1267)	51.88 (1318)	5 (127)	5	14.75 (375)	27.63 (702)
5809S	50.25 (1276)	41 (1041)	110.50 (2807)	116.66 (2963)	35.38 (899)	38 (965)	100.52 (2553)	25.125 (638)	9.38 (238)	1.375 (35)	50.94 (1267)	51.88 (1318)	5 (127)	5	14.75 (375)	27.63 (702)
5811S	50.25 (1276)	41 (1041)	110.50 (2807)	124.66 (3166)	35.38 (899)	38 (965)	100.52 (2553)	25.125 (638)	9.38 (238)	1.375 (35)	50.94 (1267)	51.88 (1318)	5 (127)	5	14.75 (375)	27.63 (702)
5811M	50.25 (1276)	41 (1041)	110.50 (2807)	136.69 (3472)	35.38 (899)	38 (965)	100.52 (2553)	25.125 (638)	9.38 (238)	1.375 (35)	103.51 (2629)	51.88 (1318)	5 (127)	5	14.75 (375)	27.63 (702)

Dimensions are subject to change. Not to be used for construction purposes unless certified.
Units may be built where foot/feet overhang the motor mounting platform. If overhang is unacceptable, consult factory for a custom submittal, quotation and/or lead time. A certified motor drawing will be required.

Fax: (847)965-8379
www.bellgossett.com

Bell & Gossett is a trademark of Xylem Inc. or one of its subsidiaries.
© 2013 Xylem Inc.

JOB: UNIT TAG: ENGINEER: CONTRACTOR:	REPRESENTATIVE: ORDER NO. SUBMITTED BY: APPROVED BY:	DATE: DATE: DATE:
---	---	--

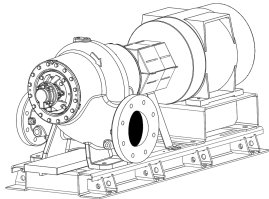

Model VSH

12x14x17 1/2 A

Double Suction Split Case Pump



SPECIFICATIONS

FLOW _____ HEAD _____

HP _____ RPM _____

VOLTS _____

CYCLE _____ PHASE _____

ENCLOSURE _____

APPROX. WEIGHT _____

SPECIALS _____

STANDARD MATERIALS OF CONSTRUCTION

- Cast Iron Bronze Fitted
- Heavy Duty Maintenance Free Bearings
- Alignment Friendly Coupling
- Heavy Duty Groutless Baseplate
- ANSI/OSHA Coupling Guard
- ISO 1940-1:2003 Impeller Balance

OPTIONAL MATERIALS OF CONSTRUCTION

- Galvanized Drip Pan
- Spacer Coupling

TYPE OF SEAL AND WORKING PRESSURE

- Standard:** 175 PSIG (12 BAR) max. working pressure, flat face flanges, 125# ANSI flange drilling, Unitized mechanical seal, EPR/Carbon/Silicon Carbide, 125 PSIG (8.5 BAR) max. suction pressure, 0 to 300°F (-18 to 149°C)
- Optional:** 300 PSIG (20 BAR) max. working pressure, flat face flanges, 250# ANSI flange drilling, Unitized mechanical seal, EPR/Carbon/Silicon Carbide, 125 PSIG (8.5 BAR) max. suction pressure, 0 to 300°F (-18 to 149°C)
- Optional:** 300 PSIG (20 BAR) max. working pressure, flat face flanges, 250# ANSI flange drilling, balanced mechanical seal, EPR/Graphite loaded Silicon Carbide on Graphite loaded Silicon Carbide, 300 PSIG (20 BAR) max. suction pressure, 0 to 300°F (-18 to 149°C)

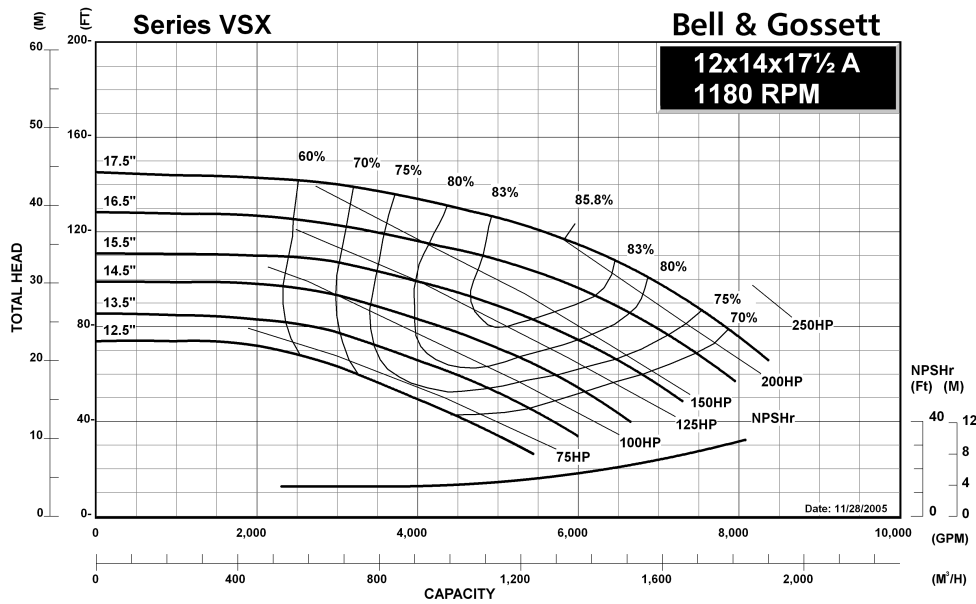

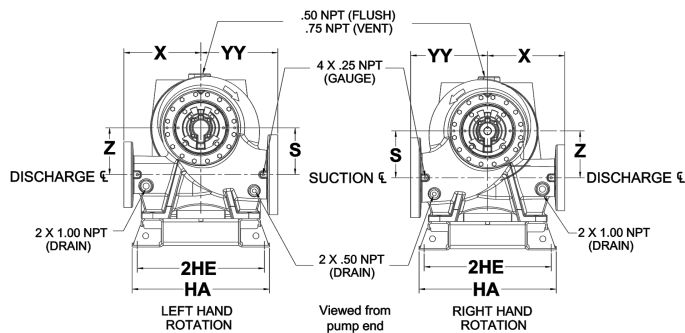

FLANGE DIMENSIONS IN INCHES (MM)			
	SIZE	THICKNESS	O.D.
Discharge	12"	2.25 (56)	20.25 (514)
Suction	14"	2.38 (60)	22.38 (568)

FLANGES ARE 125# ANSI - STANDARD
250# ANSI - AVAILABLE

DIMENSIONS IN INCHES (MM)				
S	VH	X	YY	Z
14.4 (366)	16.5 (419)	24 (610)	24 (610)	14.4 (366)

Removal clearance from end of bracket: 34 Inches (864 mm)

SPACER COUPLER

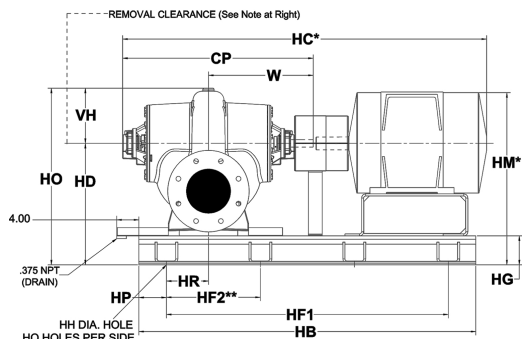

*Motor dimensions are approximate and vary by manufacturer and motor type.

**Distance to the next available hole.

MOTOR FRAME	DIMENSIONS - INCHES (mm) FOR SPACER COUPLER															
	CP	HA	HB	HC*	HD	2HE	HF ₁	HF ₂ **	HG	HH	HM*	HO	HP	HQ	HR	W
404T/TS	50.25 (1276)	41 (1041)	108 (2743)	100.06 (2542)	33 (838)	39.12 (994)	98 (2489)	19.60 (498)	7 (178)	1.13 (29)	43.47 (1104)	49.5 (1257)	5 (127)	6	14.75 (375)	27.63 (702)
405T/TS	50.25 (1276)	41 (1041)	108 (2743)	102.06 (2592)	33 (838)	39.12 (994)	98 (2489)	19.60 (498)	7 (178)	1.13 (29)	43.47 (1104)	49.5 (1257)	5 (127)	6	14.75 (375)	27.63 (702)
444T/TS	50.25 (1276)	41 (1041)	108 (2743)	107.526 (2731)	33 (838)	39.12 (994)	98 (2489)	19.60 (498)	7 (178)	1.13 (29)	48.52 (1232)	49.5 (1257)	5 (127)	6	14.75 (375)	27.63 (702)
445T/TS	50.25 (1276)	41 (1041)	108 (2743)	109.13 (2772)	33 (838)	39.12 (994)	98 (2489)	19.60 (498)	7 (178)	1.13 (29)	48.52 (1232)	49.5 (1257)	5 (127)	6	14.75 (375)	27.63 (702)
447T/TS	50.25 (1276)	41 (1041)	108 (2743)	115.61 (2936)	33 (838)	39.12 (994)	98 (2489)	19.60 (498)	7 (178)	1.13 (29)	46.88 (1191)	49.5 (1257)	5 (127)	6	14.75 (375)	27.63 (702)
449T/TS	50.25 (1276)	41 (1041)	108 (2743)	116.31 (2954)	33 (838)	39.12 (994)	98 (2489)	19.60 (498)	7 (178)	1.13 (29)	46.88 (1191)	49.5 (1257)	5 (127)	6	14.75 (375)	27.63 (702)
5008S/MS	50.25 (1276)	41 (1041)	108 (2743)	112.13 (2848)	33 (838)	39.12 (994)	98 (2489)	19.60 (498)	7 (178)	1.13 (29)	47.5 (1207)	49.5 (1257)	5 (127)	6	14.75 (375)	27.63 (702)
5010S/MS	50.25 (1276)	41 (1041)	124 (3150)	118.46 (3009)	35.38 (899)	38 (965)	114 (2896)	28.5 (724)	9.38 (238)	1.375 (35)	49.88 (1267)	51.88 (1318)	5 (127)	5	14.75 (375)	27.63 (702)
5012S/MS	50.25 (1276)	41 (1041)	124 (3150)	126.46 (3212)	35.38 (899)	38 (965)	114 (2896)	28.5 (724)	9.38 (238)	1.375 (35)	49.88 (1267)	51.88 (1318)	5 (127)	5	14.75 (375)	27.63 (702)
5807S	50.25 (1276)	41 (1041)	123.50 (3137)	122.34 (3107)	35.38 (899)	38 (965)	113.52 (2883)	28.375 (721)	9.38 (238)	1.375 (35)	50.94 (1294)	51.88 (1318)	5 (127)	5	14.75 (375)	27.63 (702)
5809S	50.25 (1276)	41 (1041)	123.50 (3137)	129.34 (3285)	35.38 (899)	38 (965)	113.52 (2883)	28.375 (721)	9.38 (238)	1.375 (35)	50.94 (1294)	51.88 (1318)	5 (127)	5	14.75 (375)	27.63 (702)
5811S	50.25 (1276)	41 (1041)	123.50 (3137)	137.34 (3488)	35.38 (899)	38 (965)	113.52 (2883)	28.375 (721)	9.38 (238)	1.375 (35)	50.94 (1294)	51.88 (1318)	5 (127)	5	14.75 (375)	27.63 (702)
5812M	50.25 (1276)	41 (1041)	123.50 (3137)	149.19 (3789)	35.38 (899)	38 (965)	113.52 (2883)	28.375 (721)	9.38 (238)	1.375 (35)	103.51 (2629)	51.88 (1318)	5 (127)	5	14.75 (375)	27.63 (702)

Dimensions are subject to change. Not to be used for construction purposes unless certified.

Units may be built where foot/feet overhang the motor mounting platform. If overhang is unacceptable, consult factory for a custom submittal, quotation and/or lead time. A certified motor drawing will be required.

These dimensions are valid when using the Woods Duraflex spacer coupling option. For dimensions on Falk SteelFlex coupling options, consult factory for a special submittal drawing.

Xylem Inc.
8200 N. Austin Avenue
Morton Grove, IL 60053
Phone: (847)966-3700
Fax: (847)965-8379
www.bellgossett.com



Bell & Gossett is a trademark of Xylem Inc. or one of its subsidiaries.
© 2013 Xylem Inc.

JOB:	REPRESENTATIVE:	
UNIT TAG:	ORDER NO.	DATE:
ENGINEER:	SUBMITTED BY:	DATE:
CONTRACTOR:	APPROVED BY:	DATE:

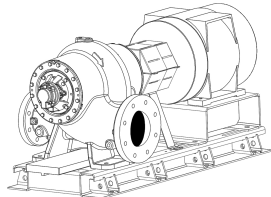

Model VSH

12x14x17 1/2 A

Double Suction Split Case Pump



SPECIFICATIONS

FLOW _____ HEAD _____

HP _____ RPM _____

VOLTS _____

CYCLE _____ PHASE _____

ENCLOSURE _____

APPROX. WEIGHT _____

SPECIALS _____

STANDARD MATERIALS OF CONSTRUCTION

- Cast Iron Bronze Fitted
- Heavy Duty Maintenance Free Bearings
- Alignment Friendly Coupling
- Heavy Duty Groutless Baseplate
- ANSI/OSHA Coupling Guard
- ISO 1940-1:2003 Impeller Balance

OPTIONAL MATERIALS OF CONSTRUCTION

- Galvanized Drip Pan
- Spacer Coupling

TYPE OF SEAL AND WORKING PRESSURE

- Standard:** 175 PSIG (12 BAR) max. working pressure, flat face flanges, 125# ANSI flange drilling, Unitized mechanical seal, EPR/Carbon/Silicon Carbide, 125 PSIG (8.5 BAR) max. suction pressure, 0 to 300°F (-18 to 149°C)
- Optional:** 300 PSIG (20 BAR) max. working pressure, flat face flanges, 250# ANSI flange drilling, Unitized mechanical seal, EPR/Carbon/Silicon Carbide, 125 PSIG (8.5 BAR) max. suction pressure, 0 to 300°F (-18 to 149°C)
- Optional:** 300 PSIG (20 BAR) max. working pressure, flat face flanges, 250# ANSI flange drilling, balanced mechanical seal, EPR/Graphite loaded Silicon Carbide on Graphite loaded Silicon Carbide, 300 PSIG (20 BAR) max. suction pressure, 0 to 300°F (-18 to 149°C)

