

<b>JOB:</b>	<b>REPRESENTATIVE:</b>	
<b>UNIT TAG:</b>	<b>ORDER NO.</b>	<b>DATE:</b>
<b>ENGINEER:</b>	<b>SUBMITTED BY:</b>	<b>DATE:</b>
<b>CONTRACTOR:</b>	<b>APPROVED BY:</b>	<b>DATE:</b>

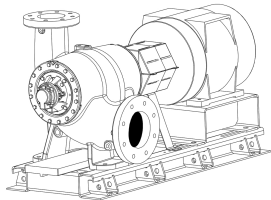

## Model VSCS 6x8x10<sup>1</sup>/<sub>2</sub>B Double Suction Split Case Pump



**SPECIFICATIONS**

FLOW \_\_\_\_\_ HEAD \_\_\_\_\_  
 HP \_\_\_\_\_ RPM \_\_\_\_\_  
 VOLTS \_\_\_\_\_  
 CYCLE \_\_\_\_\_ PHASE \_\_\_\_\_  
 ENCLOSURE \_\_\_\_\_  
 APPROX. WEIGHT \_\_\_\_\_  
 SPECIALS \_\_\_\_\_  
 \_\_\_\_\_

**STANDARD MATERIALS OF CONSTRUCTION**

- Cast Iron Bronze Fitted
- Heavy Duty Maintenance Free Bearings
- Alignment Friendly Coupling
- Heavy Duty Groutless Baseplate
- ANSI/OSHA Coupling Guard
- ISO 1940-1:2003 Impeller Balance

**OPTIONAL MATERIALS OF CONSTRUCTION**

- Galvanized Drip Pan
- Spacer Coupling

**TYPE OF SEAL AND WORKING PRESSURE**

- Standard:** 175 PSIG (12 BAR) max. working pressure, flat face flanges, 125# ANSI flange drilling, Unitized mechanical seal, EPR/Carbon/Silicon Carbide, 175 PSIG (12 BAR) max. suction pressure, 0 to 300°F (-18 to 149°C)
- Optional:** 300 PSIG (20 BAR) max. working pressure, flat face flanges, 250# ANSI flange drilling, Unitized mechanical seal, EPR/Carbon/Silicon Carbide, 200 PSIG (13.7 BAR) max. suction pressure, 0 to 300°F (-18 to 149°C)
- Optional:** 300 PSIG (20 BAR) max. working pressure, flat face flanges, 250# ANSI flange drilling, balanced mechanical seal, EPR/Graphite loaded Silicon Carbide on Graphite loaded Silicon Carbide, 300 PSIG (20 BAR) max. suction pressure, 0 to 300°F (-18 to 149°C)

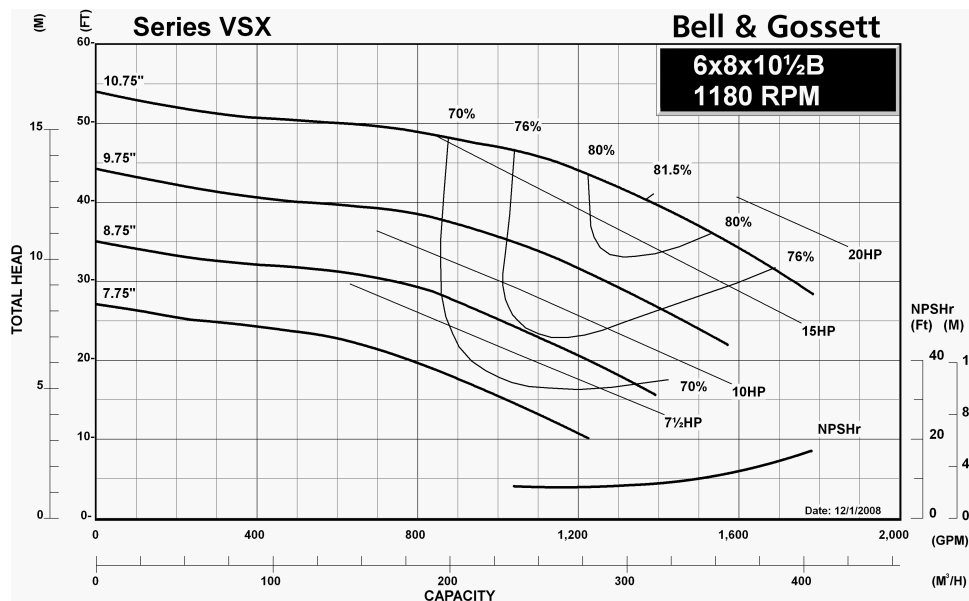

<b>JOB:</b>	<b>REPRESENTATIVE:</b>	
<b>UNIT TAG:</b>	<b>ORDER NO.</b>	<b>DATE:</b>
<b>ENGINEER:</b>	<b>SUBMITTED BY:</b>	<b>DATE:</b>
<b>CONTRACTOR:</b>	<b>APPROVED BY:</b>	<b>DATE:</b>

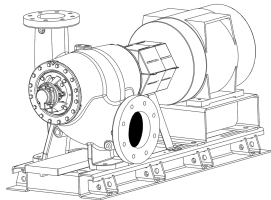

## Model VSCS 6x8x10<sup>1</sup>/<sub>2</sub>B Double Suction Split Case Pump



**SPECIFICATIONS**

FLOW \_\_\_\_\_ HEAD \_\_\_\_\_  
 HP \_\_\_\_\_ RPM \_\_\_\_\_  
 VOLTS \_\_\_\_\_  
 CYCLE \_\_\_\_\_ PHASE \_\_\_\_\_  
 ENCLOSURE \_\_\_\_\_  
 APPROX. WEIGHT \_\_\_\_\_  
 SPECIALS \_\_\_\_\_  
 \_\_\_\_\_

**STANDARD MATERIALS OF CONSTRUCTION**

- Cast Iron Bronze Fitted
- Heavy Duty Maintenance Free Bearings
- Alignment Friendly Coupling
- Heavy Duty Groutless Baseplate
- ANSI/OSHA Coupling Guard
- ISO 1940-1:2003 Impeller Balance

**OPTIONAL MATERIALS OF CONSTRUCTION**

- Galvanized Drip Pan
- Spacer Coupling

**TYPE OF SEAL AND WORKING PRESSURE**

- Standard:** 175 PSIG (12 BAR) max. working pressure, flat face flanges, 125# ANSI flange drilling, Unitized mechanical seal, EPR/Carbon/Silicon Carbide, 175 PSIG (12 BAR) max. suction pressure, 0 to 300°F (-18 to 149°C)
- Optional:** 300 PSIG (20 BAR) max. working pressure, flat face flanges, 250# ANSI flange drilling, Unitized mechanical seal, EPR/Carbon/Silicon Carbide, 200 PSIG (13.7 BAR) max. suction pressure, 0 to 300°F (-18 to 149°C)
- Optional:** 300 PSIG (20 BAR) max. working pressure, flat face flanges, 250# ANSI flange drilling, balanced mechanical seal, EPR/Graphite loaded Silicon Carbide on Graphite loaded Silicon Carbide, 300 PSIG (20 BAR) max. suction pressure, 0 to 300°F (-18 to 149°C)

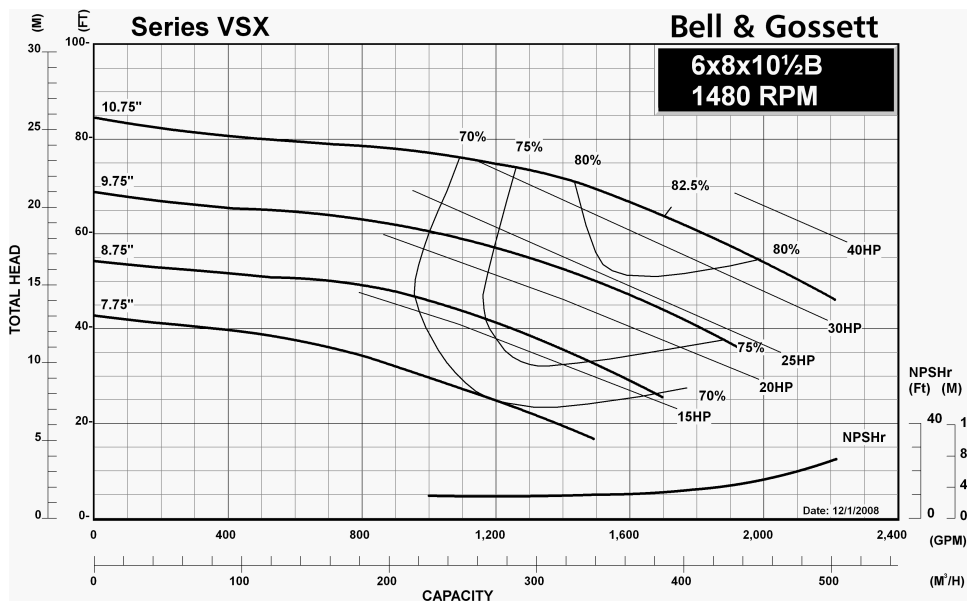

<b>JOB:</b>	<b>REPRESENTATIVE:</b>	
<b>UNIT TAG:</b>	<b>ORDER NO.</b>	<b>DATE:</b>
<b>ENGINEER:</b>	<b>SUBMITTED BY:</b>	<b>DATE:</b>
<b>CONTRACTOR:</b>	<b>APPROVED BY:</b>	<b>DATE:</b>

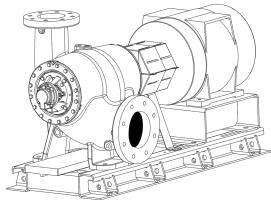

# Model VSCS 6x8x10<sup>1</sup>/<sub>2</sub>B Double Suction Split Case Pump



**SPECIFICATIONS**

FLOW \_\_\_\_\_ HEAD \_\_\_\_\_  
 HP \_\_\_\_\_ RPM \_\_\_\_\_  
 VOLTS \_\_\_\_\_  
 CYCLE \_\_\_\_\_ PHASE \_\_\_\_\_  
 ENCLOSURE \_\_\_\_\_  
 APPROX. WEIGHT \_\_\_\_\_  
 SPECIALS \_\_\_\_\_  
 \_\_\_\_\_

**STANDARD MATERIALS OF CONSTRUCTION**

- Cast Iron Bronze Fitted
- Heavy Duty Maintenance Free Bearings
- Alignment Friendly Coupling
- Heavy Duty Groutless Baseplate
- ANSI/OSHA Coupling Guard
- ISO 1940-1:2003 Impeller Balance

**OPTIONAL MATERIALS OF CONSTRUCTION**

- Galvanized Drip Pan
- Spacer Coupling

**TYPE OF SEAL AND WORKING PRESSURE**

- Standard:** 175 PSIG (12 BAR) max. working pressure, flat face flanges, 125# ANSI flange drilling, Unitized mechanical seal, EPR/Carbon/Silicon Carbide, 175 PSIG (12 BAR) max. suction pressure, 0 to 300°F (-18 to 149°C)
- Optional:** 300 PSIG (20 BAR) max. working pressure, flat face flanges, 250# ANSI flange drilling, Unitized mechanical seal, EPR/Carbon/Silicon Carbide, 200 PSIG (13.7 BAR) max. suction pressure, 0 to 300°F (-18 to 149°C)
- Optional:** 300 PSIG (20 BAR) max. working pressure, flat face flanges, 250# ANSI flange drilling, balanced mechanical seal, EPR/Graphite loaded Silicon Carbide on Graphite loaded Silicon Carbide, 300 PSIG (20 BAR) max. suction pressure, 0 to 300°F (-18 to 149°C)

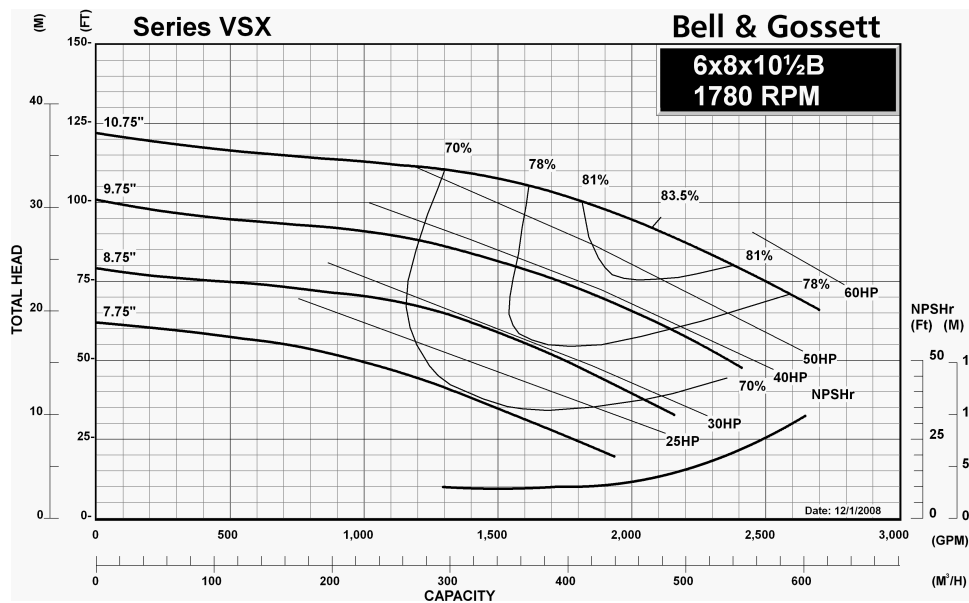

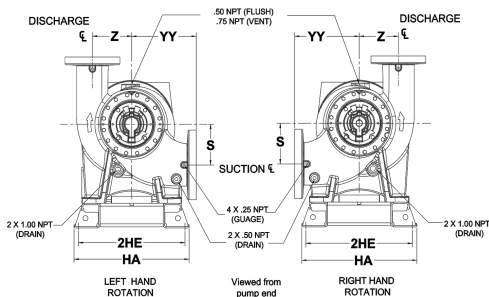

FLANGE DIMENSIONS IN INCHES (MM)			
	SIZE	THICKNESS	O.D.
Discharge	6"	1.63 (41)	12.13 (308)
Suction	8"	1.81 (46)	14.75 (375)

FLANGES ARE 125# ANSI - STANDARD  
250# ANSI - AVAILABLE

DIMENSIONS IN INCHES (MM)			
S	X	YY	Z
8.65 (220)	14.25 (362)	14.25 (362)	8.65 (220)

Removal clearance from end of bracket: 22 Inches (559 mm)

### STANDARD COUPLER

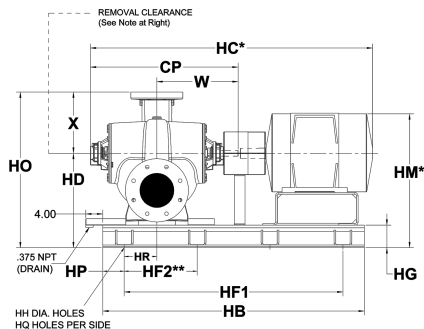

\*Motor dimensions are approximate and vary by manufacturer and motor type.

\*\*Distance to the next available hole.

MOTOR FRAME	DIMENSIONS - INCHES (mm) FOR STANDARD COUPLER															
	CP	HA	HB	HC*	HD	2HE	HF <sub>1</sub>	HF <sub>2</sub> **	HG	HH	HM*	HO	HP	HQ	HR	W
215T	34.48 (876)	25.4 (645)	61 (1549)	55.925 (1420)	22 (559)	23.52 (597)	51 (1295)	17 (432)	5.25 (133)	0.88 (22)	29.97 (759)	36.25 (921)	5 (127)	4	7.63 (194)	18.93 (481)
254T	34.48 (876)	25.4 (645)	61 (1549)	58.495 (1486)	22 (559)	23.52 (597)	51 (1295)	17 (432)	5.25 (133)	0.88 (22)	29.82 (757)	36.25 (921)	5 (127)	4	7.63 (194)	18.93 (481)
256T	34.48 (876)	25.4 (645)	61 (1549)	60.245 (1530)	22 (559)	23.52 (597)	51 (1295)	17 (432)	5.25 (133)	0.88 (22)	29.82 (757)	36.25 (921)	5 (127)	4	7.63 (194)	18.93 (481)
284T/TS	34.48 (876)	25.4 (645)	61 (1549)	61.408 (1560)	22 (559)	23.52 (597)	51 (1295)	17 (432)	5.25 (133)	0.88 (22)	29.82 (757)	36.25 (921)	5 (127)	4	7.63 (194)	18.93 (481)
286T/TS	34.48 (876)	25.4 (645)	61 (1549)	62.904 (1598)	22 (559)	23.52 (597)	51 (1295)	17 (432)	5.25 (133)	0.88 (22)	29.82 (757)	36.25 (921)	5 (127)	4	7.63 (194)	18.93 (481)
324T/TS	34.48 (876)	25.4 (645)	61 (1549)	65.725 (1669)	22 (559)	23.52 (597)	51 (1295)	17 (432)	5.25 (133)	0.88 (22)	30.57 (776)	36.25 (921)	5 (127)	4	7.63 (194)	18.93 (481)
326T/TS	34.48 (876)	25.4 (645)	61 (1549)	66.845 (1698)	22 (559)	23.52 (597)	51 (1295)	17 (432)	5.25 (133)	0.88 (22)	31.1 (790)	36.25 (921)	5 (127)	4	7.63 (194)	18.93 (481)
364T/TS	34.48 (876)	25.4 (645)	61 (1549)	68.684 (1745)	22 (559)	23.52 (597)	51 (1295)	17 (432)	5.25 (133)	0.88 (22)	31.95 (812)	36.25 (921)	5 (127)	4	7.63 (194)	18.93 (481)
365T/TS	34.48 (876)	25.4 (645)	61 (1549)	68.684 (1745)	22 (559)	23.52 (597)	51 (1295)	17 (432)	5.25 (133)	0.88 (22)	31.95 (812)	36.25 (921)	5 (127)	4	7.63 (194)	18.93 (481)

Dimensions are subject to change. Not to be used for construction purposes unless certified.

Units may be built where foot/feet overhang the motor mounting platform. If overhang is unacceptable, consult factory for a custom submittal, quotation and/or lead time. A certified motor drawing will be required.

Xylem Inc.  
8200 N. Austin Avenue  
Morton Grove, IL 60053  
Phone: (847)966-3700  
Fax: (847)965-8379  
www.bellgossett.com



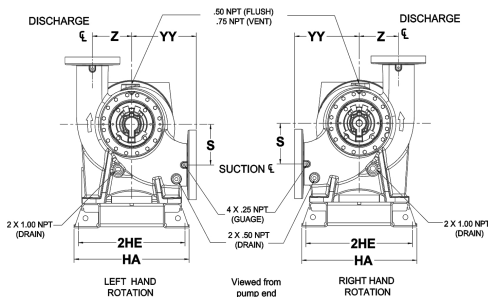

FLANGE DIMENSIONS IN INCHES (MM)			
	SIZE	THICKNESS	O.D.
Discharge	6"	1.63 (41)	12.13 (308)
Suction	8"	1.81 (46)	14.75 (375)

FLANGES ARE 125# ANSI - STANDARD  
250# ANSI - AVAILABLE

DIMENSIONS IN INCHES (MM)			
S	X	YY	Z
8.65 (220)	14.25 (362)	14.25 (362)	8.65 (220)

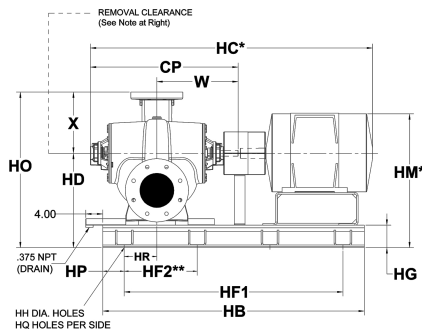

Removal clearance from end of bracket: 22 Inches (559 mm)

SPACER COUPLER

\*Motor dimensions are approximate and vary by manufacturer and motor type.

\*\*Distance to the next available hole.

MOTOR FRAME	DIMENSIONS - INCHES (mm) FOR SPACER COUPLER															
	CP	HA	HB	HC*	HD	2HE	HF <sub>1</sub>	HF <sub>2</sub> **	HG	HH	HM*	HO	HP	HQ	HR	W
215T	34.48 (876)	25.4 (645)	70 (1778)	65.175 (1655)	22 (559)	23.52 (597)	60 (1524)	15 (381)	5.25 (133)	0.88 (22)	29.97 (759)	36.25 (921)	5 (127)	5	7.62 (194)	18.93 (481)
254T	34.48 (876)	25.4 (645)	70 (1778)	67.745 (1721)	22 (559)	23.52 (597)	60 (1524)	15 (381)	5.25 (133)	0.88 (22)	29.82 (757)	36.25 (921)	5 (127)	5	7.62 (194)	18.93 (481)
256T	34.48 (876)	25.4 (645)	70 (1778)	69.495 (1765)	22 (559)	23.52 (597)	60 (1524)	15 (381)	5.25 (133)	0.88 (22)	29.82 (757)	36.25 (921)	5 (127)	5	7.62 (194)	18.93 (481)
284T/TS	34.48 (876)	25.4 (645)	70 (1778)	70.658 (1795)	22 (559)	23.52 (597)	60 (1524)	15 (381)	5.25 (133)	0.88 (22)	29.82 (757)	36.25 (921)	5 (127)	5	7.62 (194)	18.93 (481)
286T/TS	34.48 (876)	25.4 (645)	70 (1778)	72.154 (1833)	22 (559)	23.52 (597)	60 (1524)	15 (381)	5.25 (133)	0.88 (22)	29.82 (757)	36.25 (921)	5 (127)	5	7.62 (194)	18.93 (481)
324T/TS	34.48 (876)	25.4 (645)	70 (1778)	74.975 (1904)	22 (559)	23.52 (597)	60 (1524)	15 (381)	5.25 (133)	0.88 (22)	30.57 (776)	36.25 (921)	5 (127)	5	7.62 (194)	18.93 (481)
326T/TS	34.48 (876)	25.4 (645)	70 (1778)	76.095 (1933)	22 (559)	23.52 (597)	60 (1524)	15 (381)	5.25 (133)	0.88 (22)	31.1 (790)	36.25 (921)	5 (127)	5	7.62 (194)	18.93 (481)
364T/TS	34.48 (876)	25.4 (645)	80 (2032)	77.934 (1980)	22 (559)	23.52 (597)	72 (1829)	18 (457)	5.25 (133)	0.88 (22)	31.95 (812)	36.25 (921)	4 (102)	5	8.63 (219)	18.93 (481)
365T/TS	34.48 (876)	25.4 (645)	80 (2032)	77.934 (1980)	22 (559)	23.52 (597)	72 (1829)	18 (457)	5.25 (133)	0.88 (22)	31.95 (812)	36.25 (921)	4 (102)	5	8.63 (219)	18.93 (481)

Dimensions are subject to change. Not to be used for construction purposes unless certified.

Units may be built where foot/feet overhang the motor mounting platform. If overhang is unacceptable, consult factory for a custom submittal, quotation and/or lead time. A certified motor drawing will be required.

These dimensions are valid when using the Woods Duraflex spacer coupling option. For dimensions on Falk SteelFlex coupling options, consult factory for a special submittal drawing.

Xylem Inc.  
8200 N. Austin Avenue  
Morton Grove, IL 60053  
Phone: (847)966-3700  
Fax: (847)965-8379  
www.bellgossett.com

