

JOB:	REPRESENTATIVE:	
UNIT TAG:	ORDER NO.	DATE:
ENGINEER:	SUBMITTED BY:	DATE:
CONTRACTOR:	APPROVED BY:	DATE:

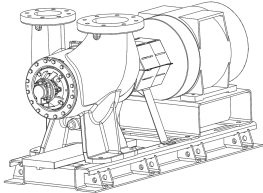

Model VSC 14x16x15A Double Suction Split Case Pump



SPECIFICATIONS

FLOW _____ HEAD _____
 HP _____ RPM _____
 VOLTS _____
 CYCLE _____ PHASE _____
 ENCLOSURE _____
 APPROX. WEIGHT _____
 SPECIALS _____

STANDARD MATERIALS OF CONSTRUCTION

- Cast Iron Bronze Fitted
- Heavy Duty Maintenance Free Bearings
- Alignment Friendly Coupling
- Heavy Duty Groutless Baseplate
- ANSI/OSHA Coupling Guard
- ISO 1940-1:2003 Impeller Balance

OPTIONAL MATERIALS OF CONSTRUCTION

- Galvanized Drip Pan
- Spacer Coupling

TYPE OF SEAL AND WORKING PRESSURE

- Standard:** 175 PSIG (12 BAR) max. working pressure, flat face flanges, 125# ANSI flange drilling, Unitized mechanical seal, EPR/Carbon/Silicon Carbide, 160 PSIG (10.9 BAR) max. suction pressure, 0 to 300°F (-18 to 149°C)
- Optional:** 300 PSIG (20 BAR) max. working pressure, flat face flanges, 250# ANSI flange drilling, Unitized mechanical seal, EPR/Carbon/Silicon Carbide, 160 PSIG (10.9 BAR) max. suction pressure, 0 to 300°F (-18 to 149°C)
- Optional:** 300 PSIG (20 BAR) max. working pressure, flat face flanges, 250# ANSI flange drilling, balanced mechanical seal, EPR/Graphite loaded Silicon Carbide on Graphite loaded Silicon Carbide, 300 PSIG (20 BAR) max. suction pressure, 0 to 300°F (-18 to 149°C)

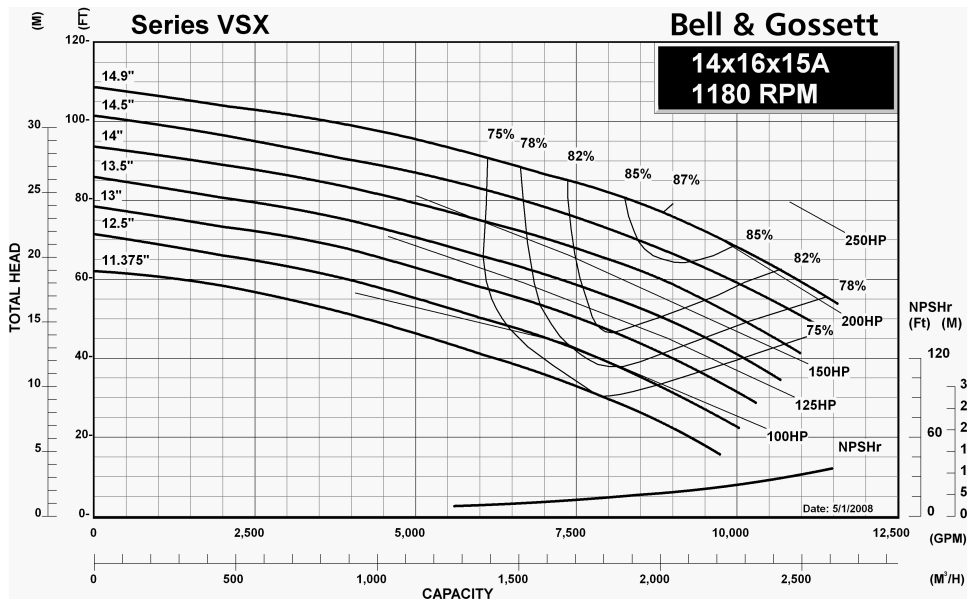

JOB:	REPRESENTATIVE:	
UNIT TAG:	ORDER NO.	DATE:
ENGINEER:	SUBMITTED BY:	DATE:
CONTRACTOR:	APPROVED BY:	DATE:

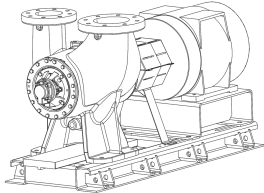

Model VSC 14x16x15A Double Suction Split Case Pump



SPECIFICATIONS

FLOW _____ HEAD _____
 HP _____ RPM _____
 VOLTS _____
 CYCLE _____ PHASE _____
 ENCLOSURE _____
 APPROX. WEIGHT _____
 SPECIALS _____

STANDARD MATERIALS OF CONSTRUCTION

- Cast Iron Bronze Fitted
- Heavy Duty Maintenance Free Bearings
- Alignment Friendly Coupling
- Heavy Duty Groutless Baseplate
- ANSI/OSHA Coupling Guard
- ISO 1940-1:2003 Impeller Balance

OPTIONAL MATERIALS OF CONSTRUCTION

- Galvanized Drip Pan
- Spacer Coupling

TYPE OF SEAL AND WORKING PRESSURE

- Standard:** 175 PSIG (12 BAR) max. working pressure, flat face flanges, 125# ANSI flange drilling, Unitized mechanical seal, EPR/Carbon/Silicon Carbide, 160 PSIG (10.9 BAR) max. suction pressure, 0 to 300°F (-18 to 149°C)
- Optional:** 300 PSIG (20 BAR) max. working pressure, flat face flanges, 250# ANSI flange drilling, Unitized mechanical seal, EPR/Carbon/Silicon Carbide, 160 PSIG (10.9 BAR) max. suction pressure, 0 to 300°F (-18 to 149°C)
- Optional:** 300 PSIG (20 BAR) max. working pressure, flat face flanges, 250# ANSI flange drilling, balanced mechanical seal, EPR/Graphite loaded Silicon Carbide on Graphite loaded Silicon Carbide, 300 PSIG (20 BAR) max. suction pressure, 0 to 300°F (-18 to 149°C)

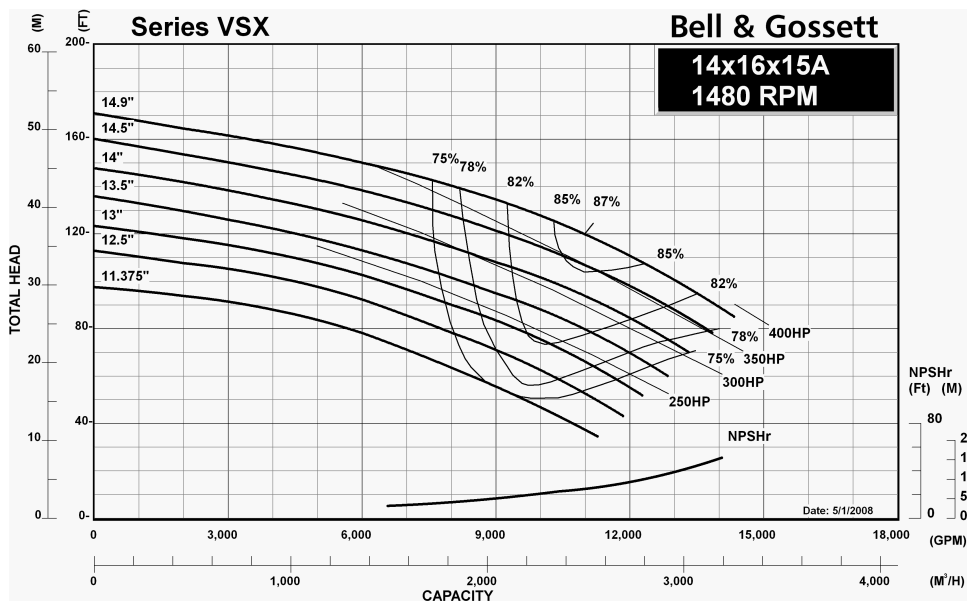

JOB:	REPRESENTATIVE:	
UNIT TAG:	ORDER NO.	DATE:
ENGINEER:	SUBMITTED BY:	DATE:
CONTRACTOR:	APPROVED BY:	DATE:

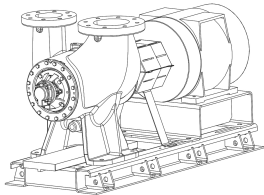

Model VSC 14x16x15A Double Suction Split Case Pump



SPECIFICATIONS

FLOW _____ HEAD _____
 HP _____ RPM _____
 VOLTS _____
 CYCLE _____ PHASE _____
 ENCLOSURE _____
 APPROX. WEIGHT _____
 SPECIALS _____

STANDARD MATERIALS OF CONSTRUCTION

- Cast Iron Bronze Fitted
- Heavy Duty Maintenance Free Bearings
- Alignment Friendly Coupling
- Heavy Duty Groutless Baseplate
- ANSI/OSHA Coupling Guard
- ISO 1940-1:2003 Impeller Balance

OPTIONAL MATERIALS OF CONSTRUCTION

- Galvanized Drip Pan
- Spacer Coupling

TYPE OF SEAL AND WORKING PRESSURE

- Standard:** 175 PSIG (12 BAR) max. working pressure, flat face flanges, 125# ANSI flange drilling, Unitized mechanical seal, EPR/Carbon/Silicon Carbide, 160 PSIG (10.9 BAR) max. suction pressure, 0 to 300°F (-18 to 149°C)
- Optional:** 300 PSIG (20 BAR) max. working pressure, flat face flanges, 250# ANSI flange drilling, Unitized mechanical seal, EPR/Carbon/Silicon Carbide, 160 PSIG (10.9 BAR) max. suction pressure, 0 to 300°F (-18 to 149°C)
- Optional:** 300 PSIG (20 BAR) max. working pressure, flat face flanges, 250# ANSI flange drilling, balanced mechanical seal, EPR/Graphite loaded Silicon Carbide on Graphite loaded Silicon Carbide, 300 PSIG (20 BAR) max. suction pressure, 0 to 300°F (-18 to 149°C)

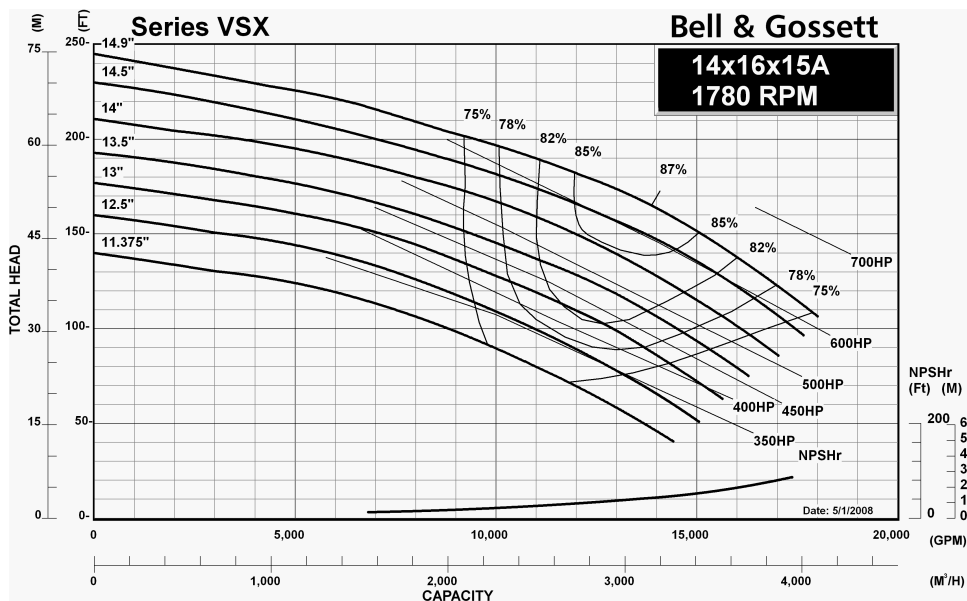

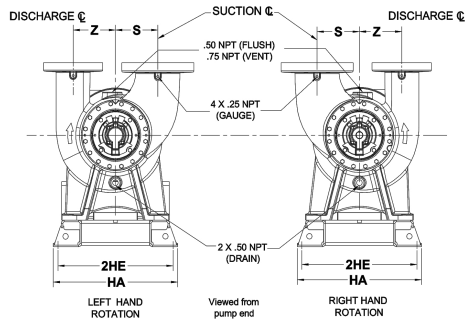

FLANGE DIMENSIONS IN INCHES (MM)			
	SIZE	THICKNESS	O.D.
Discharge	14"	2.375 (59)	22.38 (121)
Suction	16"	2.5 (64)	25.00 (635)

FLANGES ARE 125# ANSI - STANDARD
250# ANSI - AVAILABLE

DIMENSIONS IN INCHES (MM)		
S	X	Z
12.69 (322)	24 (610)	12.69 (322)

Removal clearance from end of bracket: 34 Inches (864 mm)

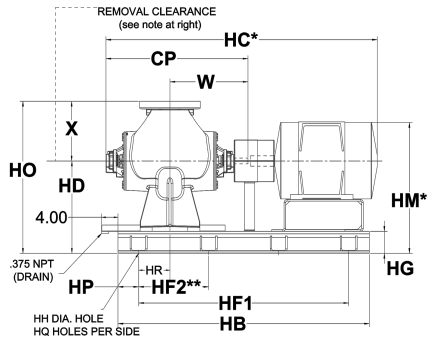

STANDARD COUPLER

*Motor dimensions are approximate and vary by manufacturer and motor type.
**Distance to the next available hole.

For all customer supplied motors above 449 NEMA frame, a certified motor drawing must be supplied by the customer at time of order entry. Submittal dimensions for motor frames above 449 NEMA are specific to ODP U.S. Electric Motors only.

DIMENSIONS - Inches (mm)

MOTOR FRAME	DIMENSIONS - INCHES (mm) FOR STANDARD COUPLER															
	CP	HA	HB	HC*	HD	2HE	HF ₁	HF ₂ **	HG	HH	HM*	HO	HP	HQ	HR	W
365T/TS	49.91 (1268)	41 (1041)	91 (2311)	84.119 (2137)	33 (838)	39.12 (813)	81 (2057)	20.25 (686)	7 (178)	1.13 (29)	42.95 (1091)	57 (1448)	5 (127)	5	14.75 (375)	27.45 (697)
404T/TS	49.91 (1268)	41 (1041)	91 (2311)	87.22 (2215)	33 (838)	39.12 (813)	81 (2057)	20.25 (686)	7 (178)	1.13 (29)	43.47 (1104)	57 (1448)	5 (127)	5	14.75 (375)	27.45 (697)
405T/TS	49.91 (1268)	41 (1041)	91 (2311)	89.22 (2266)	33 (838)	39.12 (813)	81 (2057)	20.25 (686)	7 (178)	1.13 (29)	43.47 (1104)	57 (1448)	5 (127)	5	14.75 (375)	27.45 (697)
444T/TS	49.91 (1268)	41 (1041)	91 (2311)	94.686 (2405)	33 (838)	39.12 (813)	81 (2057)	20.25 (686)	7 (178)	1.13 (29)	48.52 (1232)	57 (1448)	5 (127)	5	14.75 (375)	27.45 (697)
445T/TS	49.91 (1268)	41 (1041)	91 (2311)	96.29 (2446)	33 (838)	39.12 (813)	81 (2057)	20.25 (686)	7 (178)	1.13 (29)	48.52 (1232)	57 (1448)	5 (127)	5	14.75 (375)	27.45 (697)
447T/TS	49.91 (1268)	41 (1041)	96 (2438)	102.77 (2610)	33 (838)	39.12 (813)	86 (2184)	17.2 (437)	7 (178)	1.13 (29)	46.88 (1191)	57 (1448)	5 (127)	6	14.75 (375)	27.45 (697)
449T/TS	49.91 (1268)	41 (1041)	96 (2438)	103.47 (2628)	33 (838)	39.12 (813)	86 (2184)	17.2 (437)	7 (178)	1.13 (29)	46.88 (1191)	57 (1448)	5 (127)	6	14.75 (375)	27.45 (697)
449T/TM	49.91 (1268)	41 (1041)	96 (2438)	103.47 (2628)	33 (838)	39.12 (813)	86 (2184)	17.2 (437)	7 (178)	1.13 (29)	46.88 (1191)	57 (1448)	5 (127)	6	14.75 (375)	27.45 (697)
5008S/MS	49.91 (1268)	41 (1041)	96 (2438)	99.29 (2522)	33 (838)	39.12 (813)	86 (2184)	17.2 (437)	7 (178)	1.13 (29)	47.5 (1207)	57 (1448)	5 (127)	6	14.75 (375)	27.45 (697)
5010S/MS	49.91 (1268)	41 (1041)	108 (2743)	106.29 (2700)	35.38 (899)	38 (965)	98 (2489)	24.5 (622)	9.38 (238)	1.375 (35)	49.88 (1267)	59.38 (1508)	5 (127)	5	14.75 (375)	27.45 (697)
5807S	49.91 (1268)	41 (1041)	110.5 (2807)	109.41 (2779)	35.38 (899)	38 (965)	100.5 (2553)	25.13 (638)	9.38 (238)	1.375 (35)	50.94 (1294)	59.38 (1508)	5 (127)	5	14.75 (375)	27.45 (697)
5809S	49.91 (1268)	41 (1041)	110.5 (2807)	116.41 (2957)	35.38 (899)	38 (965)	100.5 (2553)	25.13 (638)	9.38 (238)	1.375 (35)	50.94 (1294)	59.38 (1508)	5 (127)	5	14.75 (375)	27.45 (697)
5811S	49.91 (1268)	41 (1041)	110.5 (2807)	124.41 (3160)	35.38 (899)	38 (965)	100.5 (2553)	25.13 (638)	9.38 (238)	1.375 (35)	50.94 (1294)	59.38 (1508)	5 (127)	5	14.75 (375)	27.45 (697)

Dimensions are subject to change. Not to be used for construction purposes unless certified.

Units may be built where foot/feet overhang the motor mounting platform. If overhang is unacceptable, consult factory for a custom submittal, quotation and/or lead time. A certified motor drawing will be required.

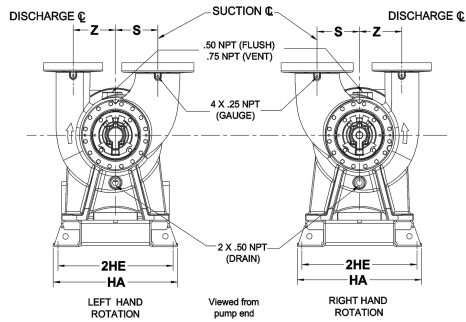

FLANGE DIMENSIONS IN INCHES (MM)			
	SIZE	THICKNESS	O.D.
Discharge	14"	2.375 (59)	22.38 (121)
Suction	16"	2.5 (64)	25.00 (635)

FLANGES ARE 125# ANSI - STANDARD
250# ANSI - AVAILABLE

DIMENSIONS IN INCHES (MM)		
S	X	Z
12.69 (322)	24 (610)	12.69 (322)

Removal clearance from end of bracket: 34 Inches (864 mm)

SPACER COUPLER

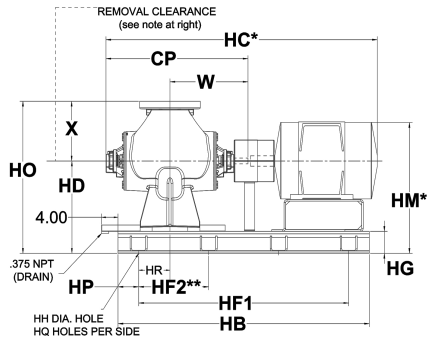

*Motor dimensions are approximate and vary by manufacturer and motor type.
**Distance to the next available hole.

For all customer supplied motors above 449 NEMA frame, a certified motor drawing must be supplied by the customer at time of order entry. Submittal dimensions for motor frames above 449 NEMA are specific to ODP U.S. Electric Motors only.

DIMENSIONS - Inches (mm)

MOTOR FRAME	DIMENSIONS - INCHES (mm) FOR SPACER COUPLER															
	CP	HA	HB	HC*	HD	2HE	HF ₁	HF ₂ **	HG	HH	HM*	HO	HP	HQ	HR	W
365T/TS	49.91 (1268)	41 (1041)	96 (2438)	97.119 (2497)	33 (838)	39.12 (994)	86 (2184)	17.20 (437)	7 (178)	1.13 (29)	42.95 (1091)	57 (1448)	5 (127)	6	14.75 (375)	27.45 (697)
404T/TS	49.91 (1268)	41 (1041)	108 (2743)	99.72 (2533)	33 (838)	39.12 (994)	98 (2489)	19.60 (498)	7 (178)	1.13 (29)	43.47 (1104)	57 (1448)	5 (127)	6	14.75 (375)	27.45 (697)
405T/TS	49.91 (1268)	41 (1041)	108 (2743)	101.72 (2584)	33 (838)	39.12 (994)	98 (2489)	19.60 (498)	7 (178)	1.13 (29)	43.47 (1104)	57 (1448)	5 (127)	6	14.75 (375)	27.45 (697)
444T/TS	49.91 (1268)	41 (1041)	108 (2743)	107.168 (2723)	33 (838)	39.12 (994)	98 (2489)	19.60 (498)	7 (178)	1.13 (29)	48.52 (1232)	57 (1448)	5 (127)	6	14.75 (375)	27.45 (697)
445T/TS	49.91 (1268)	41 (1041)	108 (2743)	108.79 (2763)	33 (838)	39.12 (994)	98 (2489)	19.60 (498)	7 (178)	1.13 (29)	48.52 (1232)	57 (1448)	5 (127)	6	14.75 (375)	27.45 (697)
447T/TS	49.91 (1268)	41 (1041)	108 (2743)	115.27 (2928)	33 (838)	39.12 (994)	98 (2489)	19.60 (498)	7 (178)	1.13 (29)	46.88 (1191)	57 (1448)	5 (127)	6	14.75 (375)	27.45 (697)
449T/TS	49.91 (1268)	41 (1041)	108 (2743)	115.97 (2946)	33 (838)	39.12 (994)	98 (2489)	19.60 (498)	7 (178)	1.13 (29)	46.88 (1191)	57 (1448)	5 (127)	6	14.75 (375)	27.45 (697)
449T/TM	49.91 (1268)	41 (1041)	108 (2743)	115.97 (2946)	33 (838)	39.12 (994)	98 (2489)	19.60 (498)	7 (178)	1.13 (29)	46.88 (1191)	57 (1448)	5 (127)	6	14.75 (375)	27.45 (697)
5008S/MS	49.91 (1268)	41 (1041)	108 (2743)	111.79 (2946)	33 (838)	39.12 (994)	98 (2489)	19.60 (498)	7 (178)	1.13 (29)	47.5 (1207)	57 (1448)	5 (127)	6	14.75 (375)	27.45 (697)
5010S/MS	49.91 (1268)	41 (1041)	124 (3150)	118.79 (3017)	35.38 (899)	38 (965)	114 (2896)	28.5 (724)	9.38 (238)	1.375 (35)	49.88 (1267)	59.38 (1508)	5 (127)	5	14.75 (375)	27.45 (697)
5807S	49.91 (1268)	41 (1041)	123.5 (3137)	121.91 (3097)	35.38 (899)	38 (965)	113.5 (2883)	28.38 (721)	9.38 (238)	1.375 (35)	50.94 (1294)	59.38 (1508)	5 (127)	5	14.75 (375)	27.45 (697)
5809S	49.91 (1268)	41 (1041)	123.5 (3137)	128.91 (3274)	35.38 (899)	38 (965)	113.5 (2883)	28.38 (721)	9.38 (238)	1.375 (35)	50.94 (1294)	59.38 (1508)	5 (127)	5	14.75 (375)	27.45 (697)
5811S	49.91 (1268)	41 (1041)	123.5 (3137)	136.91 (3478)	35.38 (899)	38 (965)	113.5 (2883)	28.38 (721)	9.38 (238)	1.375 (35)	50.94 (1294)	59.38 (1508)	5 (127)	5	14.75 (375)	27.45 (697)

Dimensions are subject to change. Not to be used for construction purposes unless certified.

Units may be built where foot/feet overhang the motor mounting platform. If overhang is unacceptable, consult factory for a custom submittal, quotation and/or lead time. A certified motor drawing will be required.

These dimensions are valid when using the Woods Duraflex spacer coupling option. For dimensions on Falk SteelFlex coupling options, consult factory for a special submittal drawing.

Xylem Inc.
8200 N. Austin Avenue
Morton Grove, IL 60053
Phone: (847)966-3700
Fax: (847)965-8379
www.bellgossett.com



Bell & Gossett is a trademark of Xylem Inc. or one of its subsidiaries.
© 2013 Xylem Inc.