



Model 2WS

2" SUBMERSIBLE SEWAGE PUMP



Bell & Gossett
a xylem brand

FEATURES

Casing: Corrosion resistant AISI 304 SS designed for long lasting performance

Impeller: AISI type 304 stainless steel construction; two vane non-clog design for maximum pumping efficiency

Mechanical Seal: Drive lube silicon carbide sealing faces; all metal components of AISI type 300 stainless steel running in protected oil chamber

Elastomers: BUNA-N

Pump Support Feet: Motor shell and lifting handle: Constructed of AISI type 304 series stainless steel

Shaft: AISI type 304 stainless steel high strength pump shaft with keyed and locking cap screw impeller fastening

Discharge: 2" NPT for horizontal connection to rigid, flexible or guide rail piping connection

APPLICATIONS

Non-clog submersible sewage pumps for simplex and duplex installations in small lift stations, drainage systems or raw water applications requiring solids handling capability of 2" diameter made specifically for:

- Homes and farms
- Mobile home parks and motels
- Schools and hospitals
- Municipal package systems
- Industrial treatment systems
- Dewatering applications

Component	Material
Pump body and motor casing	Stainless steel (AISI 304)
Impeller	Stainless steel (AISI 304)
Lower mechanical seal	Silicon carbide/silicon carbide
Upper lip seal	Nitrile rubber
Motor Shaft	Stainless steel (AISI 304)
Handle	Nylon

SPECIFICATIONS

Pump:

- 2" discharge
- Solid size: 2" solids
- Capacities: to 175 U.S. GPM (41 m³/h)
- Total heads: to 47 feet TDH (14 m)
- Temperature: 104°F (40°C) continuous, 140°F (60°C) intermitten
- Maximum submergence: to 17 feet (5 m)
- AISI 304 SS casing
- AISI 304 SS impeller
- Continuous duty rated, non-overloading motor

Motor:

- Single phase: 60 Hz, 3450 RPM; ¾ to 1 HP, 230 V
- Three phase: 60 Hz, 3450 RPM, ¾ to 1½ HP, 230 and 460 V
- Non-overloading
- Air-filled, class F insulated motor
- Thermal overload protection: built-in with automatic reset on single phase, 230 V models
- Three phase models require external overload in panel
- Power cord: 20 feet long
- Single phase 230 V models are supplied with molded NEMA plugs and built-in capacitors
- Three phase models are supplied with bare leads
- Float controls: optional, see accessory section for simplex or duplex system requirements
- Rotation is clockwise when viewed from top

AGENCY LISTINGS (Three phase only)



Tested to UL 778 and CSA 22.2 108 Standards
By Canadian Standards Association
File #LR38549

MODEL INFORMATION

Order Number	HP	Volts	Phase	RPM	Maximum Amps	Start Amps	Capacitor uF/V	Resistance Start / Line-Line	Cord Length	Discharge Connection	Solids	Weight (Lbs.)
2WS0712	¾	230	1	3450	5.4	27.2	22/450	4.4 / 1.9	20'	2"	2"	30
2WS0732			3		3.4	24.9	NA	NA / 6.0				25
2WS0734		460	1.7		12.7	NA	NA / 7.8	25				
2WS1012	1	230	1		7.0	30.6	30/450	4.2 / 1.9				34
2WS1032			3		4.4	29.8	NA	NA / 5.3				30
2WS1034		460	2.2		15.2	NA	NA / 6.6	30				
2WS1532	1½	230	3		5.6	39.2	NA	NA / 3.7				32
2WS1534		460			2.8	19.9	NA	NA / 4.8				

METERS FEET

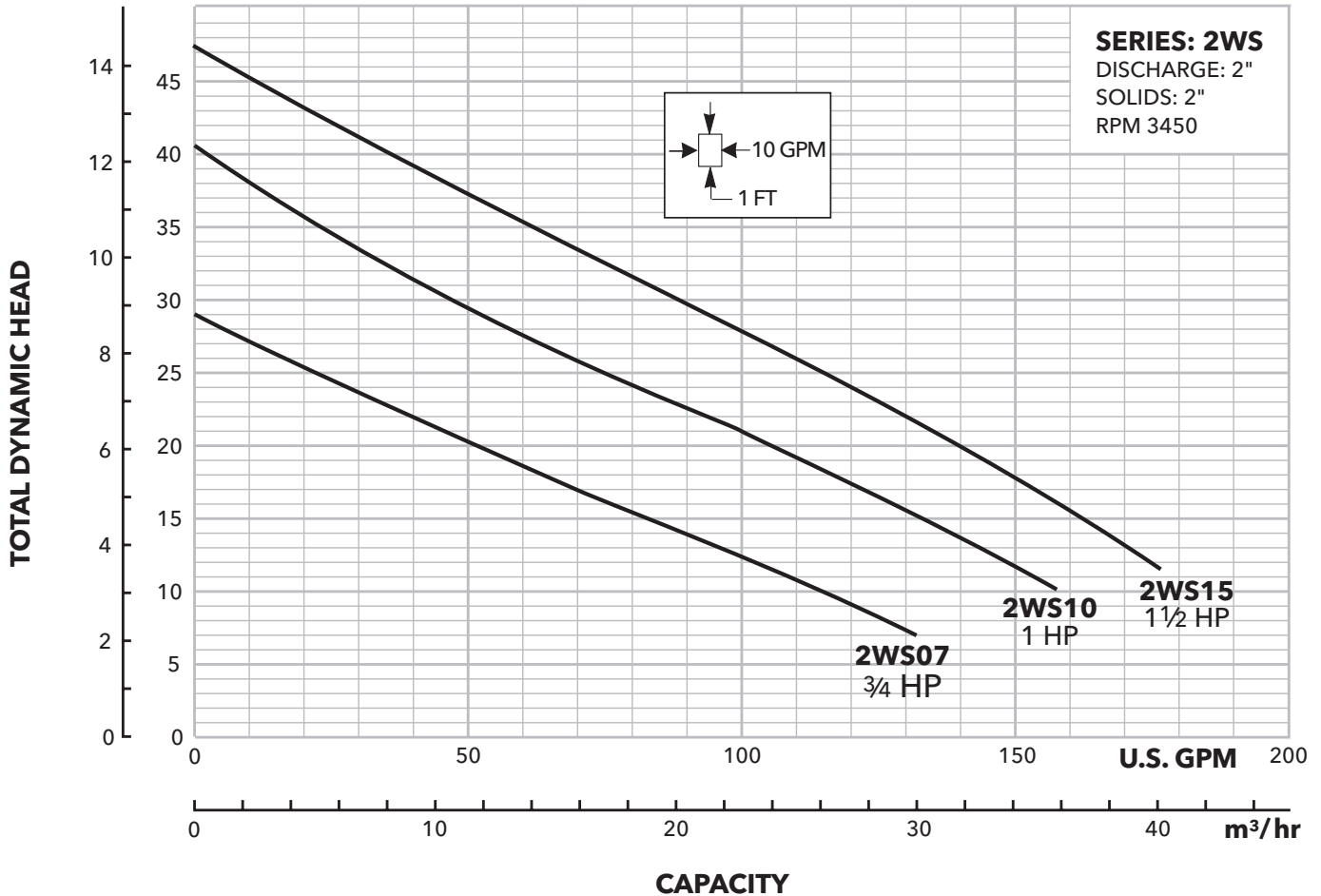

DIMENSIONS

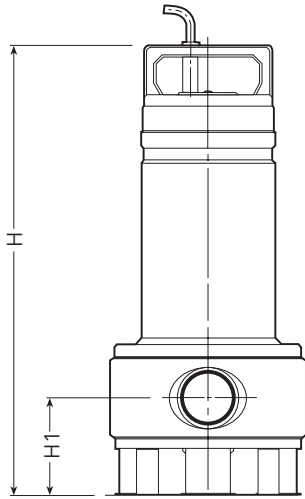

Series	HP	Phase	Dimensions in inches (mm)			Discharge Size	Wt. (lbs.)
			H	H1	L		
2DM	¾	3	17¼ (438)	4¾ (111.5)	7¾ (198)	2"	25
		1	18 (458)				30
	1	3	18 (458)				30
		1	18 (458)				34
	1½	3	18 ¹³ / ₁₆ (478)				32

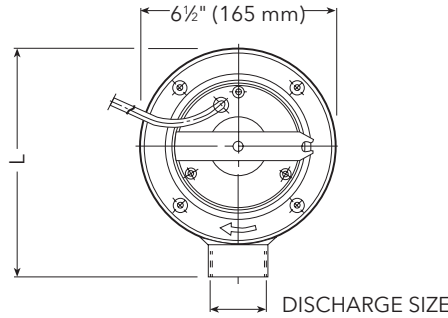

TYPICAL SPECIFICATIONS

The contractor shall furnish and install quantity _____, 2WS _____ 2" solids handling wastewater pump(s) as illustrated on the plans and in accordance with the following specifications.

The submersible wastewater solids handling pump(s) shall be ¾ to 1½ HP, single-phase, 230V or three phase, 230 or 460V. The 20' power cord shall be 16/3 SJTW with a NEMA three prong grounding plug on 1Ø and bare leads on 3Ø units. Single phase PSC motors have built-in, automatic reset thermal overloads. Three phase motors require a separately ordered starter with Class 10 overloads.

The air-filled motor shall have Class F insulation and a carbon steel shaft, upper and lower heavy duty ball bearings and be protected from water intrusion by a silicon carbide/silicon carbide mechanical shaft seal running in a protected oil chamber. Maximum fluid temperature is 104° F (40° C) for continuous operation when pump is fully submerged. Maximum submergence is 17'.

Automatic operation requires a piggyback float switch which must be ordered separately.

Pump(s) shall be designed to pass 2" maximum spheres and are suitable for residential sewage systems, heavy duty sump, dewatering and water transfer applications.

Materials of Construction are 304 stainless steel with a Nylon handle.

AGENCY LISTINGS (Three phase only)



Xylem Inc.
 Phone: (866) 325-4210
 Fax: (888) 322-5877
www.xylem.com/bellgossett

Xylem is a registered trademark of Xylem Inc. or one of its subsidiaries. Bell & Gossett is a trademark of Xylem Inc. or one of its subsidiaries. All other trademarks or registered trademarks are property of their respective owners.
 © 2022 Xylem Inc. BWS R5 September 2022