

JOB:	REPRESENTATIVE:
UNIT TAG:	ORDER NO.
ENGINEER:	SUBMITTED BY:
CONTRACTOR:	APPROVED BY:
	DATE:
	DATE:
	DATE:

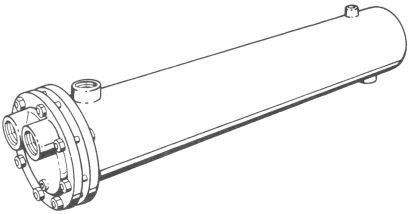

Type "HTWU" ASME High Temperature Heat Exchangers

"U" Tube Design

DESCRIPTION

B & G Types "WU" Heat Exchangers are of the shell and tube type. The tube bundle is of "U" bend construction with tube ends expanded into a stationary tube sheet. This construction permits ample expansion or contraction for wide temperature variations. A fluid entering the tubes is heated or cooled by a fluid being circulated through a baffled shell. Unit is designed for pumped circulation through both shell and tube side.

Standard "HTWU" Heat Exchangers are constructed according to ASME requirements for pressure and temperatures noted in table on the rear.

A Manufacturers' Data Report for Pressure Vessels, Form No. U-1, as required by the provisions of the ASME Code Rules, is furnished with each unit upon request.

This form is signed by an authorized inspector, holding a national Board Commission, and who is employed by an authorized inspection agency, certifying that construction conforms to the latest ASME code for pressure vessels. The ASME, "U" symbol is stamped on each vessel. In addition, each unit is registered with the National Board of Boiler and Pressure Vessel Inspectors.

RECOMMENDED "HTWU" HEAT EXCHANGER

MODEL NO. _____

HEATING SURFACE (SQ. FT.) _____

1. Type of Fluid.....
2. Flow Rate.....
3. BTU/Hr. Transfer
4. Inlet Temperature..... °F
5. Outlet Temperature..... °F
6. Coefficient (h).....
7. Fouling Factor.....
8. Overall Heat Transfer "U".....
9. Corrected Log Mean Temp. Difference.....
10. Recommended "HTWU" Heat Exchanger.....
11. Pressure Drop.....

TUBE SIDE		SHELL SIDE	
Sp. Hp.	_____	Sp. Hp.	_____
Sp. Gr.	_____	Sp. Gr.	_____
	_____		_____
	_____ °F		_____ °F
	_____ °F		_____ °F
	_____		_____
	_____		_____
	_____		_____
	_____	Area in Sq. Ft.	_____
	_____		_____

APPROVALS

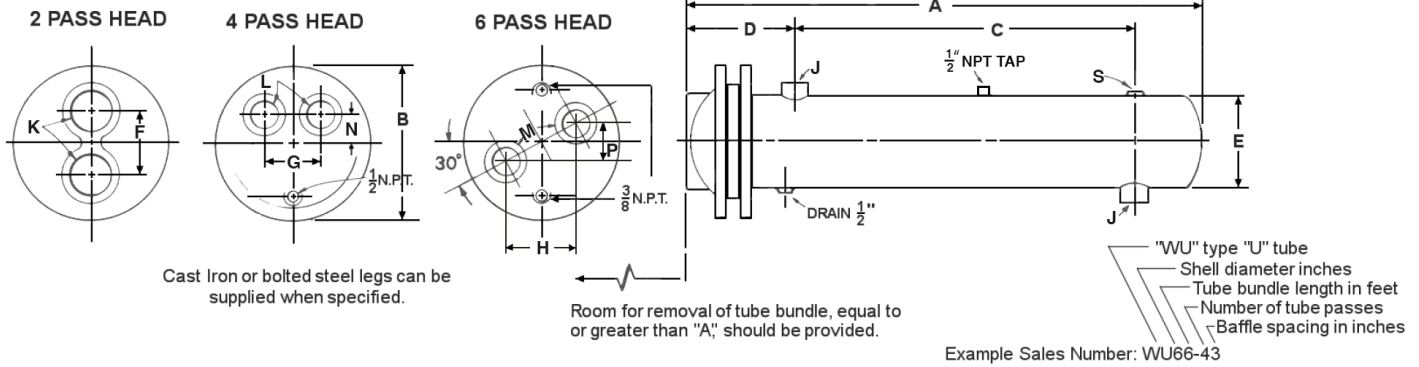

DIMENSIONS - Inches (mm)

UNIT NUMBER	STD B.S.	SQ. FT. OF H.S.			DIMENSIONS IN INCHES (MM)														
		2P	4P	6P	A	B	C	D	E	F	G	H	J	K	L	M	N	P	S
HTWU-43	4 (102)	6.8 (0.6)	6.8 (0.6)	-	40-5/8 (1032)	7-1/4 (184)	29 (737)	6-1/8 (156)	4-1/2 (114)	2-5/8 (67)	2-1/4 (57)	-	2-1/2 NPT	1-1/2 NPT	1-1/4 NPT	-	1 (25)	-	2 NPT
HTWU-44	4 (102)	9.2 (0.9)	9.2 (0.9)	-	52-5/8 (1337)	7-1/4 (184)	41 (1041)	6-1/8 (156)	4-1/2 (114)	2-5/8 (67)	2-1/4 (57)	-	2-1/2 NPT	1-1/2 NPT	1-1/4 NPT	-	1 (25)	-	2 NPT
HTWU-45	4 (102)	11.5 (1.1)	11.5 (1.1)	-	64-5/8 (1641)	7-1/4 (184)	52-1/2 (1334)	6-3/8 (162)	4-1/2 (114)	2-5/8 (67)	2-1/4 (57)	-	2-1/2 NPT	1-1/2 NPT	1-1/4 NPT	-	1 (25)	-	2 NPT
HTWU-46	4 (102)	13.9 (1.3)	13.9 (1.3)	-	76-5/8 (1946)	7-1/4 (184)	64-1/2 (1638)	6-3/8 (162)	4-1/2 (114)	2-5/8 (67)	2-1/4 (57)	-	2-1/2 NPT	1-1/2 NPT	1-1/4 NPT	-	1 (25)	-	2 NPT
HTWU-47	4 (102)	16.3 (1.5)	16.3 (1.5)	-	88-5/8 (2251)	7-1/4 (184)	76-1/2 (1943)	6-3/8 (162)	4-1/2 (114)	2-5/8 (67)	2-1/4 (57)	-	2-1/2 NPT	1-1/2 NPT	1-1/4 NPT	-	1 (25)	-	2 NPT
HTWU-63	3 (76)	12.7 (1.2)	12.7 (1.2)	9.6 (0.9)	40-1/4 (1022)	10-1/2 (267)	26-1/2 (673)	8 (203)	6-5/8 (168)	3-3/4 (95)	3-3/16 (81)	4-1/16 (103)	3 NPT	2 NPT	1-1/2 NPT	1-1/4 NPT	1-5/8 (41)	2-3/8 (60)	2 NPT
HTWU-64	3 (76)	17.4 (1.6)	17.4 (1.6)	13.1 (1.2)	52-1/4 (1327)	10-1/2 (267)	38-1/2 (978)	8 (203)	6-5/8 (168)	3-3/4 (95)	3-3/16 (81)	4-1/16 (103)	3 NPT	2 NPT	1-1/2 NPT	1-1/4 NPT	1-5/8 (41)	2-3/8 (60)	2 NPT
HTWU-65	3 (76)	22.1 (2.1)	22.1 (2.1)	16.7 (1.6)	64-1/4 (1632)	10-1/2 (267)	50-1/2 (1283)	8 (203)	6-5/8 (168)	3-3/4 (95)	3-3/16 (81)	4-1/16 (103)	3 NPT	2 NPT	1-1/2 NPT	1-1/4 NPT	1-5/8 (41)	2-3/8 (60)	2 NPT
HTWU-66	3 (76)	26.8 (2.5)	26.8 (2.5)	20.2 (1.9)	76-1/4 (1937)	10-1/2 (267)	61-3/4 (1568)	8-1/2 (216)	6-5/8 (168)	3-3/4 (95)	3-3/16 (81)	4-1/16 (103)	4 FLG	2 NPT	1-1/2 NPT	1-1/4 NPT	1-5/8 (41)	2-3/8 (60)	2 NPT
HTWU-67	3 (76)	31.5 (2.9)	31.5 (2.9)	23.8 (2.2)	88-1/4 (2242)	10-1/2 (267)	73-3/4 (1873)	8-1/2 (216)	6-5/8 (168)	3-3/4 (95)	3-3/16 (81)	4-1/16 (103)	4 FLG	2 NPT	1-1/2 NPT	1-1/4 NPT	1-5/8 (41)	2-3/8 (60)	2 NPT
HTWU-68	3 (76)	36.2 (3.4)	36.2 (3.4)	27.3 (2.5)	100-1/4 (2546)	10-1/2 (267)	85-3/4 (2178)	8-1/2 (216)	6-5/8 (168)	3-3/4 (95)	3-3/16 (81)	4-1/16 (103)	4 FLG	2 NPT	1-1/2 NPT	1-1/4 NPT	1-5/8 (41)	2-3/8 (60)	2 NPT
HTWU-84	4 (102)	32 (3)	32 (3)	26 (2.4)	53-1/8 (1349)	12-1/2 (318)	36-1/4 (921)	9-7/8 (251)	8-5/8 (219)	5 (127)	4 (102)	5-3/16 (132)	4 FLG	3 NPT	2 NPT	2 NPT	2 (51)	3 (76)	2 NPT
HTWU-85	4 (102)	41 (3.8)	41 (3.8)	33 (3.1)	65-1/8 (1654)	12-1/2 (318)	48-1/4 (1226)	9-7/8 (251)	8-5/8 (219)	5 (127)	4 (102)	5-3/16 (132)	4 FLG	3 NPT	2 NPT	2 NPT	2 (51)	3 (76)	2 NPT
HTWU-86	4 (102)	49 (4.6)	49 (4.6)	41 (3.8)	77-1/8 (1959)	12-1/2 (318)	60-1/4 (1530)	9-7/8 (251)	8-5/8 (219)	5 (127)	4 (102)	5-3/16 (132)	4 FLG	3 NPT	2 NPT	2 NPT	2 (51)	3 (76)	2 NPT
HTWU-87	4 (102)	58 (5.4)	58 (5.4)	48 (4.5)	89-1/8 (2264)	12-1/2 (318)	72-1/4 (1835)	9-7/8 (251)	8-5/8 (219)	5 (127)	4 (102)	5-3/16 (132)	4 FLG	3 NPT	2 NPT	2 NPT	2 (51)	3 (76)	2 NPT
HTWU-88	4 (102)	67 (6.2)	67 (6.2)	55 (5.1)	101-1/8 (2569)	12-1/2 (318)	84-1/4 (2140)	9-7/8 (251)	8-5/8 (219)	5 (127)	4 (102)	5-3/16 (132)	4 FLG	3 NPT	2 NPT	2 NPT	2 (51)	3 (76)	2 NPT
HTWU-89	4 (102)	75 (7)	75 (7)	62 (5.8)	113-1/8 (2873)	12-1/2 (318)	96-1/4 (2445)	9-7/8 (251)	8-5/8 (219)	5 (127)	4 (102)	5-3/16 (132)	4 FLG	3 NPT	2 NPT	2 NPT	2 (51)	3 (76)	2 NPT
HTWU-104	5 (127)	56 (5.2)	53 (4.9)	45 (4.2)	53-3/8 (1356)	14-5/8 (371)	35-3/4 (908)	10-1/8 (257)	10-3/4 (273)	6-7/8 (175)	4-3/4 (121)	6-5/8 (168)	4 FLG	3 NPT	3 NPT	2-1/2 NPT	2-3/8 (60)	3-13/16 (97)	2 NPT
HTWU-105	5 (127)	71 (6.6)	68 (6.3)	56 (5.2)	65-3/8 (1661)	14-5/8 (371)	47-3/4 (1213)	10-1/8 (257)	10-3/4 (273)	6-7/8 (175)	4-3/4 (121)	6-5/8 (168)	4 FLG	3 NPT	3 NPT	2-1/2 NPT	2-3/8 (60)	3-3/16 (81)	2 NPT
HTWU-106	5 (127)	86 (8)	82 (7.6)	68 (6.3)	77-3/8 (1965)	14-5/8 (371)	57-3/4 (1467)	11-1/8 (283)	10-3/4 (273)	6-7/8 (175)	4-3/4 (121)	6-5/8 (168)	6 FLG	3 NPT	3 NPT	2-1/2 NPT	2-3/8 (60)	3-13/16 (97)	2 NPT
HTWU-107	5 (127)	101 (9.4)	96 (8.9)	80 (7.4)	89-3/8 (2270)	14-5/8 (371)	69-3/4 (1772)	11-1/8 (283)	10-3/4 (273)	6-7/8 (175)	4-3/4 (121)	6-5/8 (168)	6 FLG	3 NPT	3 NPT	2-1/2 NPT	2-3/8 (60)	3-3/16 (81)	2 NPT
HTWU-108	5 (127)	116 (10.8)	110 (10.2)	92 (8.5)	101-3/8 (2575)	14-5/8 (371)	81-3/4 (2076)	11-1/8 (283)	10-3/4 (273)	6-7/8 (175)	4-3/4 (121)	6-5/8 (168)	6 FLG	3 NPT	3 NPT	2-1/2 NPT	2-3/8 (60)	3-13/16 (97)	2 NPT
HTWU-109	5 (127)	131 (12.2)	124 (11.5)	104 (9.7)	113-3/8 (2880)	14-5/8 (371)	93-3/4 (2381)	11-1/8 (283)	10-3/4 (273)	6-7/8 (175)	4-3/4 (121)	6-5/8 (168)	6 FLG	3 NPT	3 NPT	2-1/2 NPT	2-3/8 (60)	3-3/16 (81)	2 NPT
HTWU-124	4 (102)	83 (7.7)	78 (7.2)	68 (6.3)	54 (1372)	16-5/8 (422)	32-1/2 (826)	12-1/8 (308)	12-3/4 (324)	8-3/4 (222)	5-7/8 (149)	7-13/16 (198)	6 FLG	3 NPT	3 NPT	3 NPT	2-5/8 (67)	4-1/2 (114)	2 NPT

Type "HTWU" ASME High Temperature Heat Exchangers ("U" Tube Design)

C-135C

DIMENSIONS – Inches (mm)

UNIT NUMBER	STD B.S.	SQ. FT. OF H.S.			DIMENSIONS IN INCHES (MM)														
		2P	4P	6P	A	B	C	D	E	F	G	H	J	K	L	M	N	P	S
HTWU-125	4 (102)	104 (9.7)	98 (9.1)	85 (7.9)	66 (1676)	16-5/8 (422)	44-1/2 (1130)	12-1/8 (308)	12-3/4 (324)	8-3/4 (222)	5-7/8 (149)	7-13/16 (198)	6 FLG	3 NPT	3 NPT	3 NPT	2-5/8 (67)	4-1/2 (114)	2 NPT
HTWU-126	4 (102)	126 (11.7)	119 (11.1)	103 (9.6)	78 (1981)	16-5/8 (422)	56-1/2 (1435)	12-1/8 (308)	12-3/4 (324)	8-3/4 (222)	5-7/8 (149)	7-13/16 (198)	6 FLG	3 NPT	3 NPT	3 NPT	2-5/8 (67)	4-1/2 (114)	2 NPT
HTWU-127	4 (102)	147 (13.7)	139 (12.9)	121 (11.2)	90 (2286)	16-5/8 (422)	66-1/4 (1683)	13-3/8 (340)	12-3/4 (324)	8-3/4 (222)	5-7/8 (149)	7-13/16 (198)	8 FLG	3 NPT	3 NPT	3 NPT	2-5/8 (67)	4-1/2 (114)	2 NPT
HTWU-128	4 (102)	169 (15.7)	160 (14.9)	139 (12.9)	102 (2591)	16-5/8 (422)	78-1/4 (1988)	13-3/8 (340)	12-3/4 (324)	8-3/4 (222)	5-7/8 (149)	7-13/16 (198)	8 FLG	3 NPT	3 NPT	3 NPT	2-5/8 (67)	4-1/2 (114)	2 NPT
HTWU-129	4 (102)	191 (17.7)	180 (16.7)	156 (14.5)	114 (2896)	16-5/8 (422)	90-1/4 (2292)	13-3/8 (340)	12-3/4 (324)	8-3/4 (222)	5-7/8 (149)	7-13/16 (198)	8 FLG	3 NPT	3 NPT	3 NPT	2-5/8 (67)	4-1/2 (114)	2 NPT
HTWU-1210	4 (102)	212 (19.7)	200 (18.6)	174 (16.2)	126 (3200)	16-5/8 (422)	102-1/4 (2597)	13-3/8 (340)	12-3/4 (324)	8-3/4 (222)	5-7/8 (149)	7-13/16 (198)	8 FLG	3 NPT	3 NPT	3 NPT	2-5/8 (67)	4-1/2 (114)	2NPT

Dimensions are subject to change. Not to be used for construction purposes unless certified.

ALL UNITS ARE CONSTRUCTED IN ACCORDANCE WITH ASME BOILER AND PRESSURE VESSEL CODE AND

STAMPED FOR: 400 PSI W.P. -(TUBE)- 800 PSI TEST
150 PSI W.P. -(SHELL)- 300 PSI TEST
400 °F. DESIGN TEMPERATURE - SHELL & TUBE

Caution: A properly sized relief valve must be installed on the heated side to protect heat exchangers from possible damage due to volumetric expansion.

DESIGN PRESSURES

SHELL DIAMETER	TUBE	SHELL
4"	400	150
6"	400	150
8"	400	150
10"	400	150
12"	400	150

MATERIALS

PARTS	MATERIALS
Shell	Steel
Head	Cast Ductile Iron
Tubes 3/4" O.D.	90-10 Cupro Nickel
Tube Sheets	Steel
Baffles	Steel
Nuts & Bolts	Steel
Gaskets	Spiral Wound #304 S.S.

Xylem Inc.
8200 N. Austin Avenue
Morton Grove, IL 60053
Phone: (847)966-3700
Fax: (847)965-8379
www.bellgossett.com

Bell & Gossett is a trademark of Xylem Inc. or one of its subsidiaries.
© 2015 Xylem Inc.

xylem
Let's Solve Water