

JOB:	REPRESENTATIVE:
UNIT TAG:	ORDER NO.
ENGINEER:	SUBMITTED BY:
CONTRACTOR:	APPROVED BY:
	DATE:
	DATE:
	DATE:

## Bell & Gossett Simplex or Duplex MiniBooster Pressure Boosters

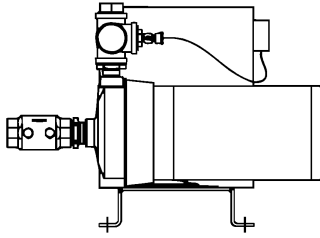

**Simplex**

System Capacity: \_\_\_\_\_ GPM  
 Discharge Pressure: \_\_\_\_\_ PSIG  
 Suction Pressure: \_\_\_\_\_ PSIG

**Pump Data**

Gallons Per Minute: \_\_\_\_\_  
 Pump TDH (Feet): \_\_\_\_\_

Series 3530

- 1" x 1-1/4" with 1-1/2" System Connections
- 1-1/4" x 1-1/2" with 1-1/2" System Connections

Motor HP: \_\_\_\_\_  
 Motor RPM: \_\_\_\_\_  
 Voltage: \_\_\_\_\_  
 Hertz: \_\_\_\_\_  
 Phase: \_\_\_\_\_

**Options - (Shipped Loose)**

- PRV –  1-1/4"  1-1/2"  2" –  NPT or  FLNG
- Low Suction Cut Out Switch
- Tank – Model Number \_\_\_\_\_

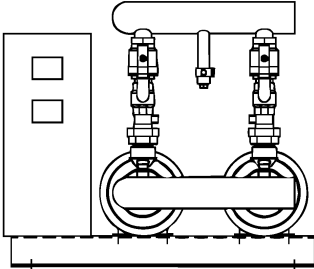

**Duplex**

System Capacity: \_\_\_\_\_ GPM  
 Discharge Pressure: \_\_\_\_\_ PSIG  
 Suction Pressure: \_\_\_\_\_ PSIG

**PumpData**

Gallons Per Minute (Pump 1): \_\_\_\_\_  
 Gallons Per Minute (Pump 2): \_\_\_\_\_  
 Pump TDH (Feet): \_\_\_\_\_

Series 3530

- 1" x 1-1/4" with 2" Copper Headers
- 1-1/4" x 1-1/2" with 3" Copper Headers

Motor HP: \_\_\_\_\_  
 Motor RPM: \_\_\_\_\_  
 Voltage: \_\_\_\_\_  
 Hertz: \_\_\_\_\_  
 Phase: \_\_\_\_\_

## Dimensions

### SIMPLEX

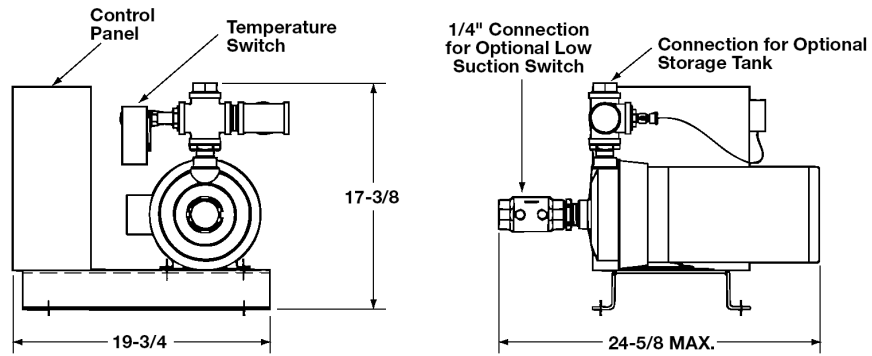

**MAXIMUM WEIGHT 206 LBS.**

### DUPLEX

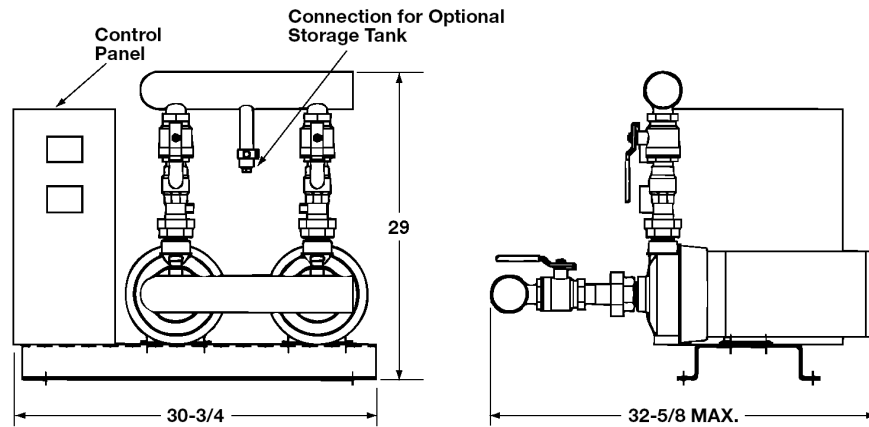

**MAXIMUM WEIGHT 410 LBS.**