



4" BFK Series

SUBMERSIBLE SEWAGE PUMPS



Bell & Gossett
a xylem brand

FEATURES

SELF-CLEANING: The patented design of the self-cleaning K-impeller has been proven to reduce clogging and maintain efficiency when pumping wastewater

POWERFUL: An efficient air-filled motor provides built-in thermal overload protection allowing the pump to run continuously without overheating

ROBUST: Components are made from robust cast iron for long life and easy maintenance

DURABLE: Heavy-duty long life bearings provide peace of mind

APPLICATIONS

Used in a variety of residential, commercial and industrial applications such as:

- Sewage systems
- Flood and pollution control
- Dewatering/effluent
- Farms
- Hospitals
- Trailer courts
- Motels

SPECIFICATIONS

- **Capacity:** up to 1600 GPM
- **Total head:** up to 112 feet
- **Insulation:** Class F: 310° F (155° C)
- **Maximum Fluid Temperature:** 104° F (40° C)
- **Phase:** Three-phase
- **Frequency:** 60 Hz
- **Impeller:** BFK Series: Self-cleaning K-impeller
- **Motor:** Air-filled 1750 rpm
- **Bearings:** Single row ball bearings
- **Upper-Lower Seal Configurations (configurations vary by model):**
 - Carbon/Aluminum Oxide - Aluminum Oxide/WCCR
 - Carbon/WCCR - WCCR/WCCR
- **Cable Length:** 50 ft (16 m) power cord

AGENCY LISTINGS



Tested to UL 778 and CSA 22.2 108 standards by Canadian Standards Association

PRODUCT SPECIFICATIONS

B&G Part No.	HP	Phase	Hz	Voltage	Max Amps	Weight (lbs.)
4BFK5022U	5	3	60	200	16	210
4BFK5023U				230	14	
4BFK5024U				460	6.9	
4BFK1022W	10			200	31	309
4BFK1023W				230	26	
4BFK1024W				460	13	
4BFK2022Y	20			200	59	397
4BFK2023Y				230	52	
4BFK2024Y				460	26	

DIMENSIONS

4BFK 5 HP

A = 20.63"

B = 18.27"

C = 7.05"

D = 11.22"

E = 6.34"

F = 7.64"

G = 4.29"

4BFK 10 HP

A = 23.31"

B = 20.59"

C = 8.39"

D = 12.21"

E = 7.64"

F = 9.13"

G = 4.61"

4BFK 20 HP

A = 26.26"

B = 20.91"

C = 7.91"

D = 12.99"

E = 7.28"

F = 8.66"

G = 4.33"

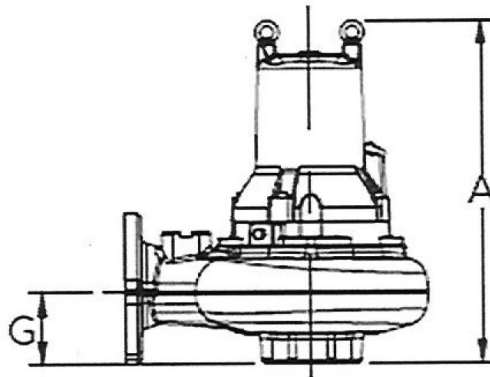
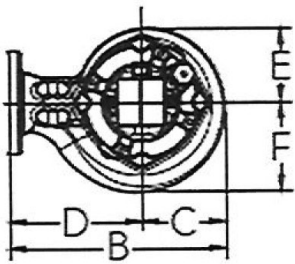

PERFORMANCE CURVES

4" BFK 5 HP - U

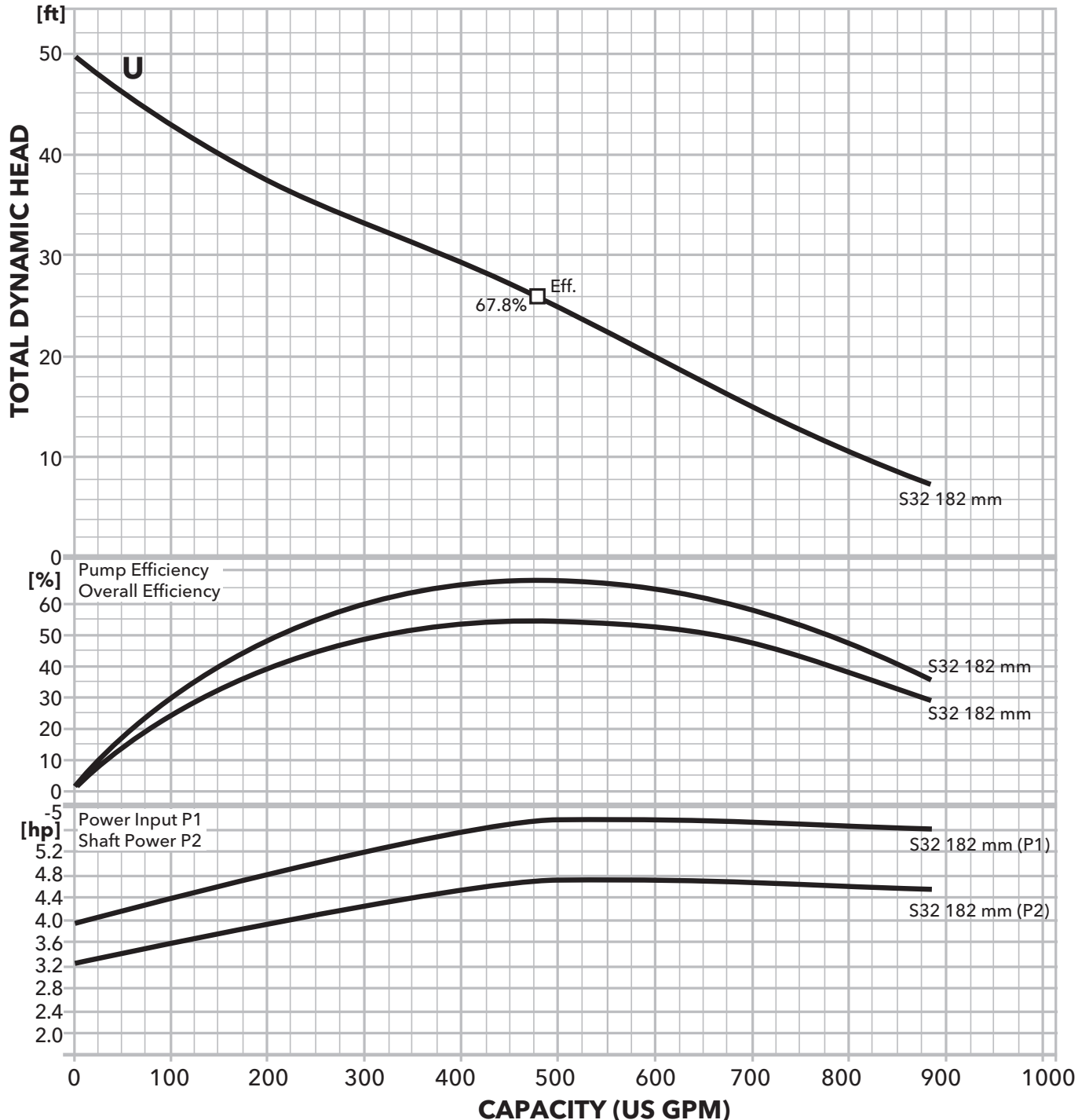

PERFORMANCE CURVES

4" BFK 10 HP - W

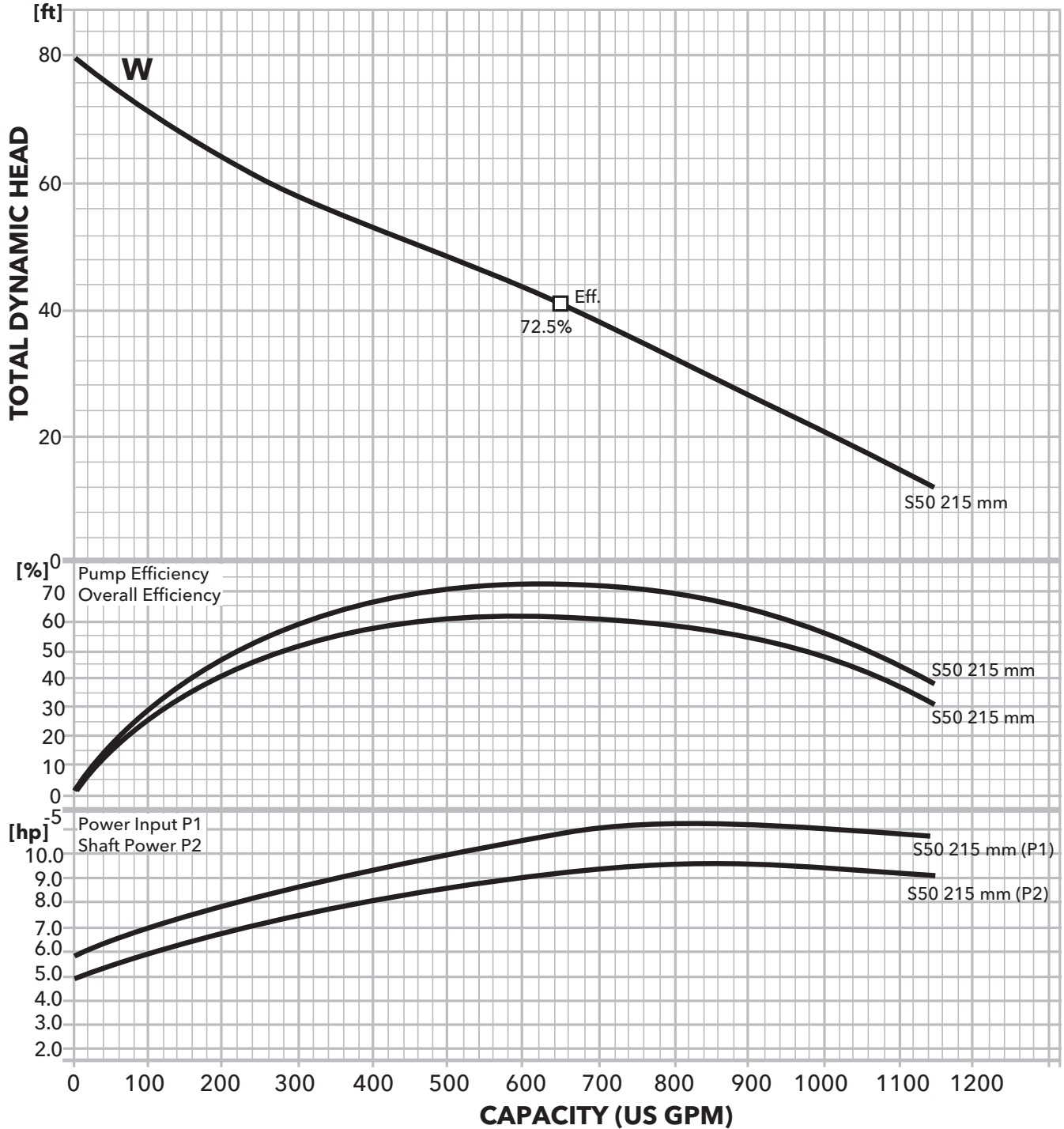

PERFORMANCE CURVES

4" BFK 20 HP - Y

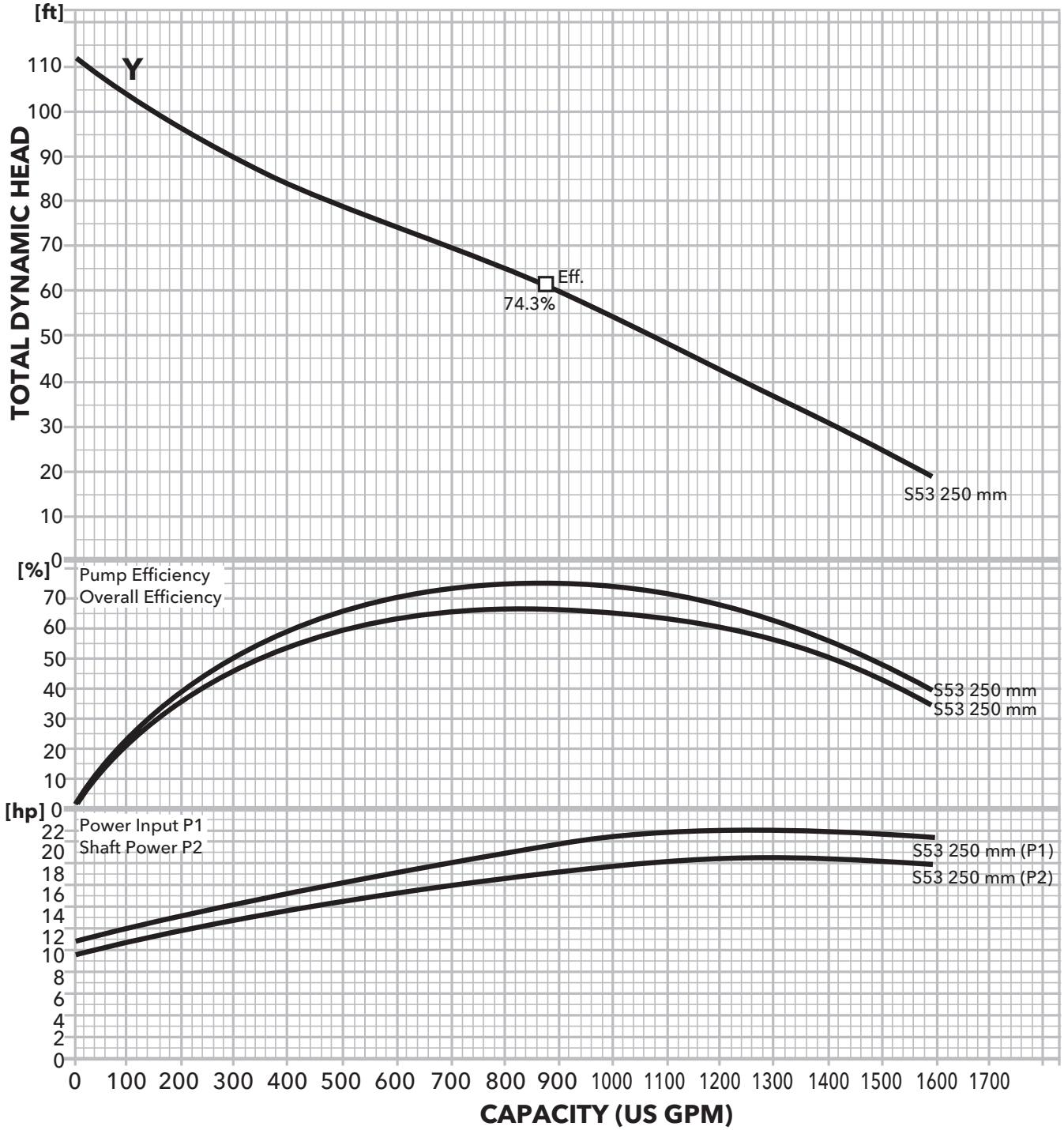

NOTES

Xylem |'zīləm|

- 1) The tissue in plants that brings water upward from the roots;
- 2) a leading global water technology company.

We're a global team unified in a common purpose: creating advanced technology solutions to the world's water challenges. Developing new technologies that will improve the way water is used, conserved, and re-used in the future is central to our work. Our products and services move, treat, analyze, monitor and return water to the environment, in public utility, industrial, residential and commercial building services settings. Xylem also provides a leading portfolio of smart metering, network technologies and advanced analytics solutions for water, electric and gas utilities. In more than 150 countries, we have strong, long-standing relationships with customers who know us for our powerful combination of leading product brands and applications expertise with a strong focus on developing comprehensive, sustainable solutions.

For more information on how Xylem can help you, go to www.xylem.com



Xylem Inc.
Phone: (866) 325-4210
Fax: (888) 322-5877
www.xylem.com/bellgossett

Bell & Gossett is a trademark of Xylem Inc. or one of its subsidiaries.
© 2020 Xylem Inc. BBG4INBFK February 2020