



4XWC

SUBMERSIBLE 4" NON-CLOG EXPLOSION PROOF SEWAGE PUMP



Bell & Gossett

a xylem brand

Wastewater

FEATURES

Impeller: Cast iron, two vane closed design for high efficiency and maximum wear life. Balanced for smooth operation.

Bronze Wear Ring: Replaceable to renew the running clearances and efficiencies to original conditions.

Casing: Heavy duty cast iron, volute type for maximum efficiency. 4" 125# ANSI cast iron flanged. Adaptable to guide rail mounting system.

Tandem Seals: Two independently mounted mechanical face type seals are separated by an oil filled chamber. The oil chamber acts as a barrier to trap moisture and provide time for a planned shutdown and maintenance. The oil provides lubrication to the internal (upper) seal. Carbon rotating and ceramic stationary faces are standard on both internal (upper) and external (lower) seals. Optional materials are available for the lower seals. See the Nomenclature Page for order number changes to order either silicon carbide/silicon carbide faces with Viton or silicon carbide/tungsten carbide faces with Viton elastomers. These are recommended for applications containing fine solids or abrasives as found in parking lot/garage drainage and construction dewatering jobs.

Moisture Protection System: Two-wire, dual moisture sens-

ing probes are located in the oil filled chamber between the inner and outer seals. When connected to a control panel with an optional Moisture Detection System and an alarm it will detect the presence of moisture should the outer seal fail. It will also detect moisture in the motor chamber and provide a warning prior to water levels reaching the bearing or stator.

Designed for Continuous Operation: Motor is rated continuous duty submerged condition in water that is 40°C or below. Maximum runtime with pump unsubmerged for 7½-40 HP is 15 minutes. Motor is suitable for 10 starts per hour.

Bearings: Ball, single-row, angular contact, Conrad type bearings with a Class 3 internal fit conforming to AFBMA Standard 20 are used. The bearings are greased for life with a premium moisture resistant polyurea thickened grease containing rust inhibitors and suitable for operation over a range of - 25° C to + 120° C.

Impeller Mounting Screw: 300 series stainless steel with anti-rotational locking patch.

Castings: All iron castings are ASTM A48 class 30 gray cast iron.

APPLICATIONS

Heavy duty design features for a wide range of commercial and industrial applications such as:

- Sewage systems
- Flood and pollution control
- Industrial dewatering
- Wastewater treatment plants
- Municipal and subdivision lift stations

SPECIFICATIONS

Pump:

- Solids handling capabilities: 3" maximum.
- Discharge size: 4" 125# ANSI flanged.
- Capacities: up to 1160 GPM.
- Total heads: up to 140 feet.
- Minimum flow: 100 GPM.
- Maximum flow: end of published curve.
- Mechanical seals: 304 stainless steel metal parts, BUNA-N elastomers with carbon/rotary and ceramic/stationary faces standard for upper and lower seals. Optional lower seals are available with Viton elastomers and either silicon carbide/silicon carbide or silicon carbide/tungsten carbide faces.
- Fasteners: 300 series stainless steel

Motor:

- **Explosion Proof Motor:** Motors up to and including 40 HP are rated as Class F, 1.15 service factor and are certified explosion proof for Class I, Division I, Groups C and D locations.
- CSA certified motors (Canadian Standards Association).

- UL (Underwriters Laboratories) Listed Motors.
- Three phase motors only.
- Available voltages: 200, 230, 400, 460 and 575 volt, 60 Hz.
- HP Range: 7.5 - 40
- Motor shaft is a one-piece design of high strength 416 stainless steel.
- All motors are air-filled and designed for continuous duty when fully submerged or for up to 15 minutes operation in air.
- NEMA design "B" with copper windings.
- Class "F" stator winding designed for inverter duty.
- Moisture System: Two wire dual probe monitoring system constantly monitors seal oil chamber and stator housing for moisture. **Note:** control panel must contain an alarm circuit and alarm device.
- Two (2) normally-closed, automatic reset thermostats connected in series and embedded in adjoining phases.
- Power and sensor cords are 25' standard length, 50' available as an option.
- Motors conform to the latest applicable requirements of NEMA, IEEE, ANSI and NEC standards.

NOTICE: Class 10 quick trip overload protection must be provided in control panel.

AGENCY LISTINGS



Tested to UL 778 and CSA 22.2 108 Standards
By Canadian Standards Association
File #218526

MOTOR LISTED EXPLOSION PROOF
CLASS I, DIVISION I, GROUPS C & D



SERIES 4XWC MODEL AND MOTOR INFORMATION (All ratings at 3 phase, 60 Hz. Consult factory for 3 phase, 50 Hz applications.)

Order Number	HP	Phase	Volts	RPM	Impeller Dia. (In.)	Impeller Code	S.F. Amps	Service Factor	Full Load Amps	Locked Rotor Amps	Power Cable Size	Sensor Cable Size	Frame Size	Weight (lbs.)
4XWC4K2A2M1C	7.5	3	200	1750	7.50	M	27.0	1.15	24.2	183.8	8/4	18/5	210TY	455
4XWC4K3A2M1C			230				23.4		21.0	160.0	8/4			
4XWC4K4A2M1C			460				11.7		10.5	80.0	8/4			
4XWC4K5A2M1C			575				9.4		8.4	64.0	14/4			
4XWC4L2A2K1C	10		200		8.00	K	35.6		31.1	186.2	8/4			
4XWC4L3A2K1C			230				31.0		27.0	162.0	8/4			
4XWC4L4A2K1C			460				15.5		13.5	81.0	8/4			
4XWC4L5A2K1C			575				12.3		10.8	64.0	14/4			
4XWC4M2A2G1C	15		200		9.00	G	54.8		48.2	256.0	6/4			
4XWC4M3A2G1C			230				47.8		42.0	222.0	8/4			
4XWC4M4A2G1C			460				23.9		21.0	111.0	8/4			
4XWC4M5A2G1C			575				19.1		16.8	88.7	10/4			
4XWC4N2A2E1C	20		200		9.75	E	74.8		64.4	342.0	4/4			
4XWC4N3A2E1C			230				65.0		56.0	298.0	6/4			
4XWC4N4A2E1C			460				32.5		28.0	149.0	6/4			
4XWC4N5A2E1C			575				26.0		22.4	119.0	10/4			
4XWC4P2A2C1C	25	200	10.38	C	83.6	72.5	394.0	2/4						
4XWC4P3A2C1C		230			72.8	63.0	342.0	4/4						
4XWC4P4A2C1C		460			36.4	31.5	171.0	4/4						
4XWC4P5A2C1C		575			29.1	25.2	137.0	8/4						
4XWC4Q2A2B1C	30	200	10.75	B	103.2	89.7	472.0	2/4						
4XWC4Q3A2B1C		230			89.6	78.0	410.0	2/4						
4XWC4Q4A2B1C		460			44.8	39.0	205.0	2/4						
4XWC4Q5A2B1C		575			35.8	31.2	164.0	8/4						
4XWC4R2A2A1C	40	200	11.00	A	132.8	114.4	600.0	1/0/4						
4XWC4R3A2A1C		230			115.4	99.4	522.0	1/4						
4XWC4R4A2A1C		460			57.7	49.7	261.0	6/4						
4XWC4R5A2A1C		575			46.2	39.8	209.0	8/4						
4XWC4K2A3D1C	7.5	200	1150	10.12	D	30.4	26.5	131.6	8/4					
4XWC4K3A3D1C		230				26.4	23.0	114.4	10/4					
4XWC4K4A3D1C		460				13.2	11.5	57.2	10/4					
4XWC4K5A3D1C		575				10.6	9.2	45.8	14/4					
4XWC4L2A3A1C	10	200	11.00	A	40.0	35.0	186.0	8/4						
4XWC4L3A3A1C		230			34.8	30.4	161.0	8/4						
4XWC4L4A3A1C		460			17.4	15.2	80.7	8/4						
4XWC4L5A3A1C		575			13.9	12.2	64.5	12/4						

NOMENCLATURE DESCRIPTION

1st - 3rd Character - Discharge Size

4 = 4" 125 # ANSI Flanged Discharge
 X = Explosion Proof Pump with Dual Seals and Seal Fail (moisture) Sensors
 W = Wastewater (Sewage)

4th Character - Impeller Design

C = Enclosed Impeller

5th Character - Phase

4 = Three Phase with On-Winding, Pilot Duty, Thermal Sensors

6th Character - Horsepower

K = 7.5 M = 15 P = 25 R = 40
 L = 10 N = 20 Q = 30

7th Character - Voltage / Phase

2 = 200 / 3 4 = 460 / 3 6 = 380/400 / 3
 3 = 230 / 3 5 = 575 / 3

8th Character - Discharge Style

A = ANSI Vertical Flange for Horizontal Discharge

9th Character - Motor RPM / Hertz

2 = 1750/60 3 = 1150/60 6 = 1450/50

10th Character - Impeller Code

A = 11.0" 10/1150 40/1750 20/1450
 B = 10.75" 30/1750
 C = 10.38" 25/1750
 D = 10.12" 7.5/1150 15/1450
 E = 9.75" 20/1750
 G = 9.00" 15/1750 10/1450
 K = 8.00" 10/1750 7.5/1450
 M = 7.50" 7.5/1750
 T = SPECIAL TRIM

11th Character - Lower (outer) Mechanical Seal

1 = Standard Seal - the upper seal is carbon/ceramic, the lower seal is carbon/ceramic, BUNA elastomers and 304 SS metal parts.
 2 = Optional Lower Seal - silicon carbide/silicon carbide, Viton elastomers and 304 SS metal parts.
 3 = Optional Lower Seal - silicon carbide/tungsten carbide, Viton elastomers and 304 SS metal parts.

12th Character - Cord Length - Power and Sensor Cords

C = 25' standard F = 50'

13th Character - Options

2 = Epoxy Coating

APPLICATION DATA

Maximum Solid Size	3"
Minimum Casing Thickness	5/16"
Casing Corrosion Allowance	1/8"
Maximum Working Pressure	100 PSI
Maximum Submergence	200 feet
Maximum Environmental Temperature	40°C (104°F) ambient conditions
Maximum Starts Per Hour	Maximum of 10 evenly spaced starts per hour

CONSTRUCTION DETAILS

Power Cable - Type	1/0 / 4, 2/4, 4/4, 6/4, 8/4, 10/4, 12/4 SOW or SOOW (see Model Info)
Control / Sensor Cable / Type	Type 18/5 SOW
Power Cable and Cap Assembly	Leads have a BUNA-N grommet in addition to being epoxy encapsulated
Power and Control Cable Lengths	25' standard, 50' optional
Motor Enclosure	Cast iron ASTM A-48 Class 30
Motor Shaft	Series 416 Stainless steel
Motor Design	NEMA design "B" with copper windings and designed to withstand 200 psi water pressure at all seal locations. Air-filled NEMA 210TY frame on 7.5, 10, 15 and 20 HP models. Air-filled NEMA 250TYS frame on 25 - 40 HP models.
Motor Insulation Rating	Class "F" insulation
Motor Thermal Protection	Two (2) normally closed on-winding thermostats open at 320° F (160° C), automatic reset closes at 221° F (105° C).
Motor Overload Protection	Class 10, ambient compensated, quick-trip overload protection must be provided in control panel.
Motor Moisture Protection	Two (2) moisture sensing probes in the oil-filled seal chamber must be connected to a relay in control panel.
Casing	Cast iron ASTM A-48 Class 30
Impeller	Cast iron ASTM A-48 Class 30
Impeller Type	Two vane enclosed design for maximum efficiency.
Casing/Impeller/Wear Ring	Replaceable bronze wear ring
External Hardware	Stainless steel

STANDARD PARTS

Ball Bearing	Lubricated for life bearings are designed for a minimum L10 life of 30,000 hours.	
210 and 250 Frame	Upper	Single row Radial (upper)
	Lower	Single row Thrust (lower)
Mechanical Seals - Standard	Upper	Carbon/rotary and ceramic/stationary
	Lower	
Mechanical Seals - Optional	Lower	Silicon carbide/rotary and tungsten carbide/stationary
	Lower	Silicon carbide/rotary and silicon carbide/stationary
Standard Motor O-rings	BUNA-N (nitrile)	
Seal Chamber Oil	Premium moisture resistant polyurea thickened grease containing rust inhibitors is suitable for operation over a temperature range of - 25° C to +120° C.	

DIMENSIONS

(All dimensions are in inches. Do not use for construction purposes.)

HP	RPM	"A" Dimensions (in.)
7½	1750	41.3
10		
15		
20		
25		
30	1150	46.6
40		
7½		
10		41.3

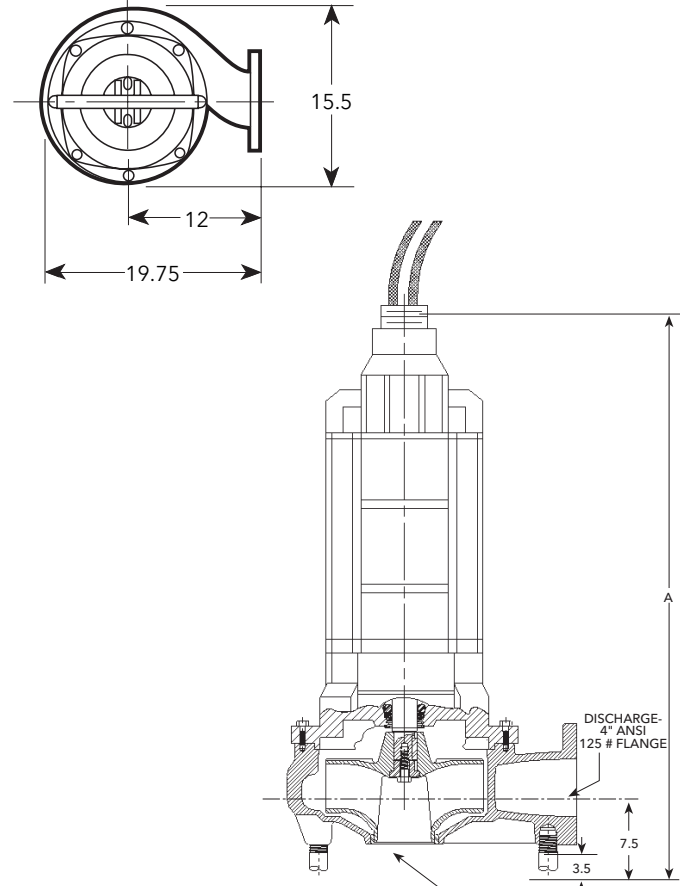

xylem
Let's Solve Water

Xylem, Inc.
2881 East Bayard Street Ext., Suite A
Seneca Falls, NY 13148
Phone: (866) 325-4210
Fax: (888) 322-5877
www.xylem.com/bellgossett

Xylem and Bell & Gossett are registered trademarks of Xylem Inc. or one of its subsidiaries. All other trademarks or registered trademarks are property of their respective owners.
© 2024 Xylem Inc. B4XWC R4 October 2024