

# Flygt 2075.690

DEWATERING PUMP

60 Hz

## Tough pumps for dewatering

The Flygt dewatering pumps from Xylem are designed for tough operating conditions. The pumps are ideal for applications in which the water or liquid contains high amounts of clay, stone chips, drilling fines etc, or to pump heavy sediment from tanks, sumps and containers.

This explosion-proof, cast iron dewatering pump is designed for heavy-duty applications in which the liquids are corrosive, abrasive or contains salt water.

Our dewatering pumps are backed by an outstanding support and world-wide presence. Operating in over 150 countries, we bring many years of experience to bear in order to keep your business moving.



**FLYGT**  
a xylem brand

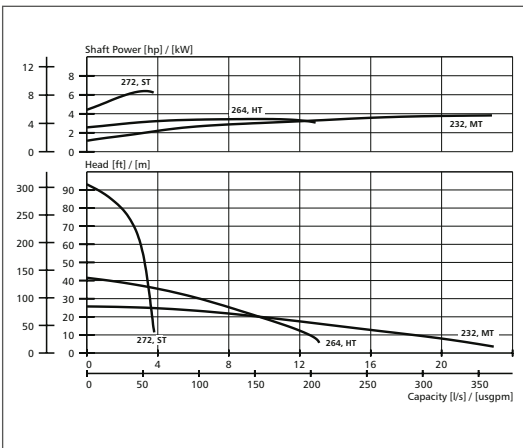
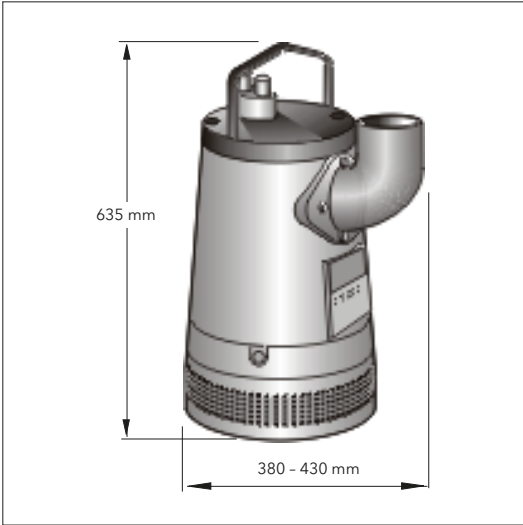

Voltage (V)	Rated current (A)	Starting current (A)
550	5.4	25
575	5.8	23
600	5.5	27
1100	2.7	13

### Flygt 2075.690

Submersible pump for dewatering building yards, draining water in flooded areas, and other similar applications. The pump can handle water containing relatively abrasive solids.

#### Denomination

Product code	2075.690
Installation	S
Impeller characteristics	MT, HT, ST
Discharge connection	2", 3", 4"

#### Process data

Liquid temperature	max +40° C
Depth of immersion	max 20 m
The pH of the pumped liquid	pH 5.5 - 14
Liquid density	max 1100 kg/m <sup>3</sup>
Strainer hole size	8 mm x 8 mm

#### Motor data

Squirrel cage 3-phase induction motor.	
Frequency	60 Hz
Insulation class	F (+155° C)
Voltage variation	
- continuously running	max ± 5%
- intermittent running	max ± 10%
Voltage imbalance between phases	max 2%
No. of starts/hour	max 15

#### Monitoring equipment

Thermal contacts.	
-------------------	--

#### Cable

Direct-on-line and Y/D start	SUBCAB®
------------------------------	---------

#### Materials

Outer casing	Grey iron
Impeller	MT
Spring steel/stainless steel	ST
Aluminium bronze	
Wear parts lining	Nitrile rubber
Stator housing	Cast iron
Strainer	Stainless steel
Shaft	Stainless steel
O-rings	Nitrile rubber

#### Mechanical face seals

Inner	Corrosion resistant cemented carbide
Outer	Corrosion resistant cemented carbide

Approvals  
EN 50014, EN 50018, EEX de IIB T3

#### Weight

Total (excl. cable)	70 - 94 kg
---------------------	------------

#### Options

Impeller (MT, HT)	Stainless steel
O-rings	Viton

Warm liquid version, threaded house connection, starters, strainer for heavy contaminated water, various cable sizes, zinc anodes, protective ring for cable entrance cover, siemens cable monitor (L-version.690), sait cable monitor (L-version.690)

#### Accessories

Adapters, hose connections and other mechanical accessories.  
Electrical accessories such as pump controller, control panels, starters, monitoring relays.

#### Rating

3~	
Rated output	4.0 kW
Speed of rotation	3400 rpm



www.flygt.com  
www.xyleminc.com