



GSD SERIES

SUBMERSIBLE SEWAGE PUMP



The GSD Series Submersible Sewage Pump features a durable cast iron build and a premium mechanical seal design for long-lasting performance.

Available as an automatic or manual, this single phase, 115v 2" NPT pump also features a cast iron recessed vortex impeller really performs. This "Complete. Reliable. Blue." pump is designed to handle residential sewage systems, water transfer, heavy-duty sump and dewatering applications.

FEATURES

- Premium silicon carbide/silicon carbide mechncl seall design provides superior protection against sand and abrasive damage
- Cast iron motor housing and oil filled construction for optimal heat dissipation
- Cast iron recessed vortex impeller for durable performance
- Corrosion resistant stainless steel (300 series) motor shaft and hardware for lifetime use
- Reliable mechanical switch coupled with a solid float for consistent on and off operation (automatic version)
- Built in anti-siphon hole to prevent air locking
- Engineered motor designed for peak hydraulic performance without overloading
- Approved for residential use (CSA/CUS Listed)
- Three (3) year Goulds Water Technology warranty / Four (4) year GPDA warranty

Model Series	Part No.	Operation	HP	Volts	Phase	Discharge	Turn On	Turn Off	Housing	Weight
GSD	GSD0511	Automatic	0.5	115	1	2" NPT	12"	4"	Cast iron	45
GSD	GSD0511M	Manual	0.5	115	1	2" NPT	-	-	Cast iron	44

GSD Series

GSD SPECIFICATIONS

Motor

Horse Power	.5 hp
Voltage	115V
Phase	Single
Hertz	60 Hz
Type	Permanent split capacitor (PSC)
Insulation	Class B
Maximum Amps	8.74 amps
Mechanical Switch	CSA/UL listed 15A/125V - automatic version
Circuit Breaker	15A

Pump

Operation	Automatic or Manual
Auto On/Off Points	12" on / 4" off
Discharge Size	2" NPT
Solids Handling	2" spherical solids
Cord Length/Type	20' SJTW power cord with NEMA grounded plug
Maximum Head	22'
Maximum Flow Rate	115 gpm (5 ft head)
Max. Operating Temp	129 °F
Cooling	Oil-filled
Motor Protection	Auto reset thermal overload

GSD PERFORMANCE CURVE

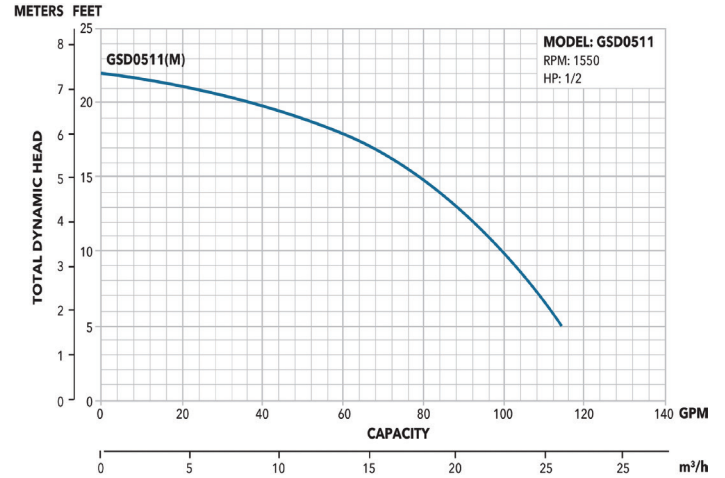

COMPONENTS

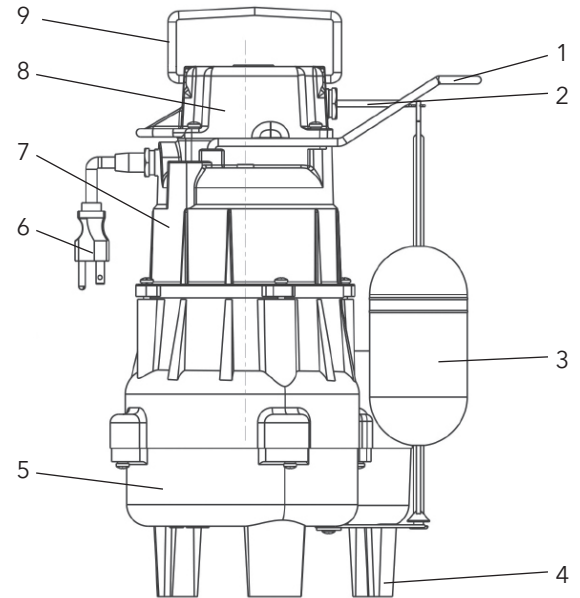

Item No.	Description
1	Float Bracket
2	Float Rod
3	Float
4	Base
5	Seal Housing
6	Plug
7	Motor Dome
8	Mechanical Switch Housing
9	Handle

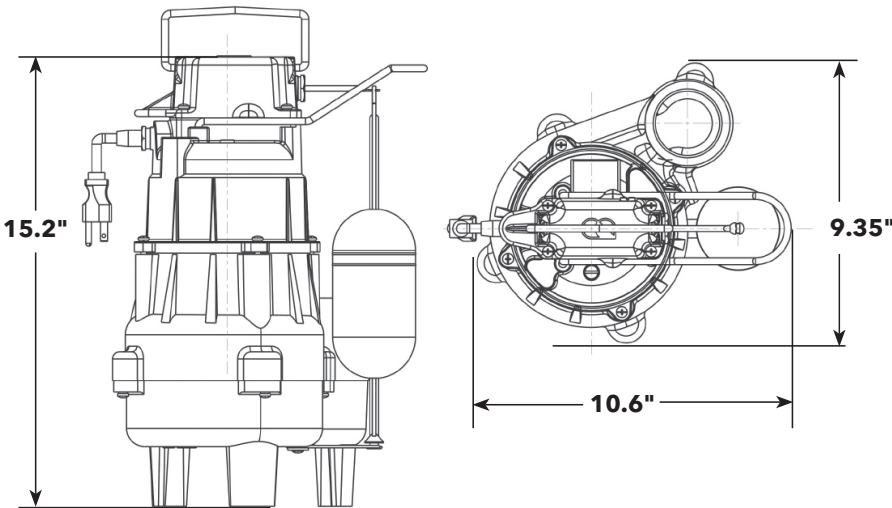

Xylem Inc.
Phone: (866) 325-4210 • Fax: (888) 322-5877
www.xylem.com/goulds

Xylem is a registered trademark of Xylem Inc. or one of its subsidiaries. Goulds is a registered trademark of ITT Manufacturing Enterprises LLC and is used under license. All other trademarks or registered trademarks are property of their respective owners.
© 2024 Xylem Inc. GSDBASINSALES24F R3 June 2024

Learn more about
GSD Series Pumps

