



GSP Cast Iron Family

1/3 and 1/2 HP sump and effluent pumps



Stamped with reliability

Goulds Water Technology proudly offers the family of GSP pumps, arguably one of the world's most durable 1/3 and 1/2 HP cast iron sump pumps.

The Goulds Water Technology signature waterdrop symbol stamped on the top of every GSP pump is just one way we differentiate ourselves from the competitors and ensure that our customers know they are receiving only the best the industry has to offer.

The GSP Series (GSP0311/GSP0511) are robust cast iron effluent and sump pumps specifically designed to keep basements and flood prone areas dry. Ideal for residential and small commercial installations.

Features and benefits

- A state-of-the-art, long-life, easy-to-replace switch coupled with a solid float for dependable performance.
- A variety of models are available with 9', 15' and 25' power cord lengths.
- Premium silicon carbide/silicon carbide seals (standard) and wide suction strainer provide superior protection against sand, debris and abrasive damage.

Combining these features with our proven industry-standard features, the GSP family of pumps delivers reliable, long-term performance in demanding applications—reflecting the engineering rigor and durability that define Goulds Water Technology.

Dimensions

	A	B	C	D	E
GSP0311	10.2"	11.8"	3.25"	7.5"	11.8"
GSP0511	12"	10.6"	5"	7.4"	10.6"

0311

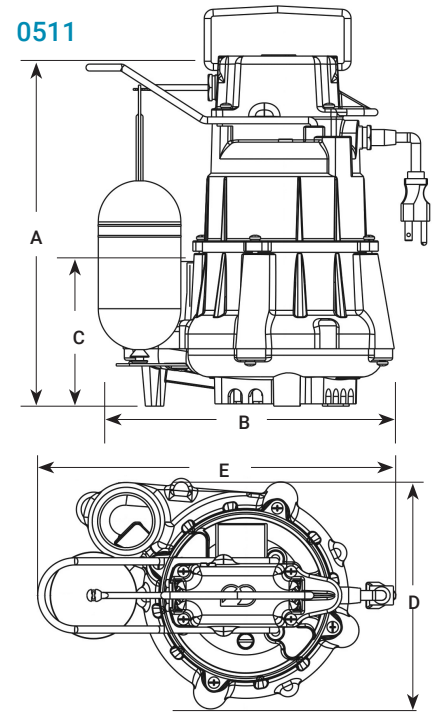
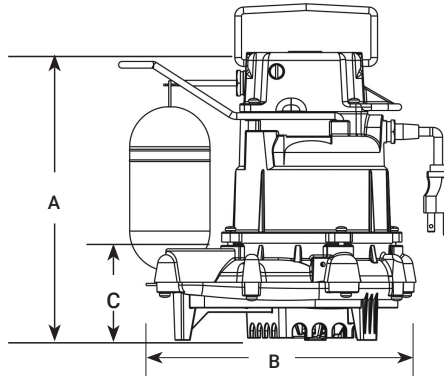
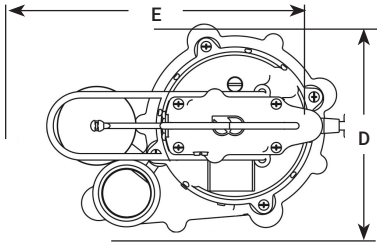

Performance curves

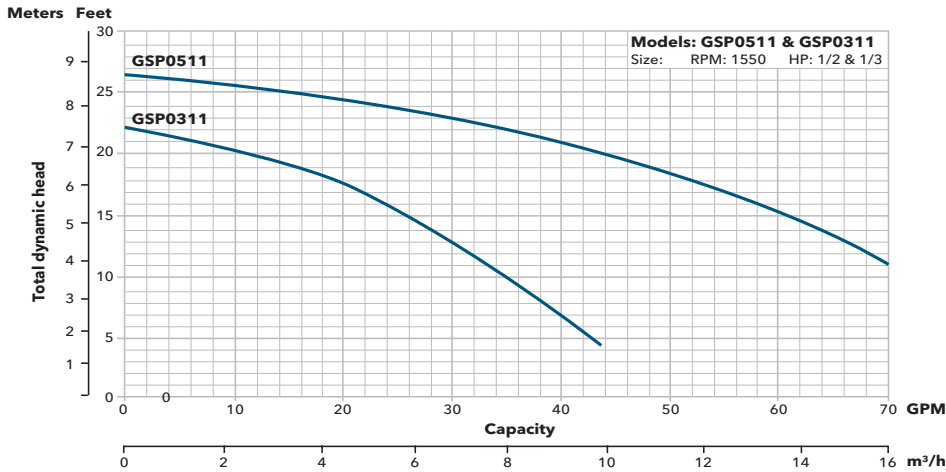

Product specifications

Model	Part no.	HP	Volts	Amps	Minimum circuit breaker	Phase	Float switch style	Cord length ft (m)	Discharge connection	Minimum on level in (mm)	Minimum off level in (mm)	Minimum basin diameter ft (m)	Max. solids size in (mm)	Shipping weight lb (kg)
GSP	GSP0511	1/2	115	8	15A	1	Vertical	15 (4.6)	1 1/2"	8 1/2 (215.9)	3 (76)	1 (.3)	1/2 (12.7)	38 (17)
GSP	GSP0311	1/3	115	10	15A	1	Vertical	9 (2.7)	1 1/2"	7 1/4 (184.2)	3 1/2 (89)	1 (.3)	1/2 (12.7)	27 (12)
GSP	GSP0311-25	1/3	115	10	15A	1	Vertical	25 (7.6)	1 1/2"	7 1/4 (184.2)	3 1/2 (89)	1 (.3)	1/2 (12.7)	28 (13)

Agency listings



Tested to UL778 CAN 22.2 by CSA International (Canadian Standards Association)

Xylem Inc.
2881 East Bayard Street Ext.,
Suite A
Seneca Falls, NY 13148

Phone: (866) 325-4210
Fax: (888) 322-5877
www.xylem.com/goulds

Subject to change without notice. All information presented herein is believed reliable and in accordance with accepted engineering practices. Xylem makes no warranties as to the completeness of this information. Users are responsible for evaluating individual product suitability for specific applications. Xylem assumes no liability whatsoever for any special, indirect or consequential damages arising from the sale, resale or misuse of its products.

©2025 Xylem is a registered trademark of Xylem Inc. or one of its subsidiaries. Goulds Water Technology is a registered trademark of ITT Manufacturing Enterprises LLC and is used under license. All other trademarks or registered trademarks are the property of their respective owners.