

SD Simplex SDS12228

Control Panel Schematic and Layout

CONTROL PANEL SCHEMATIC

FNAME: SDS12228

REVDATE: 0523

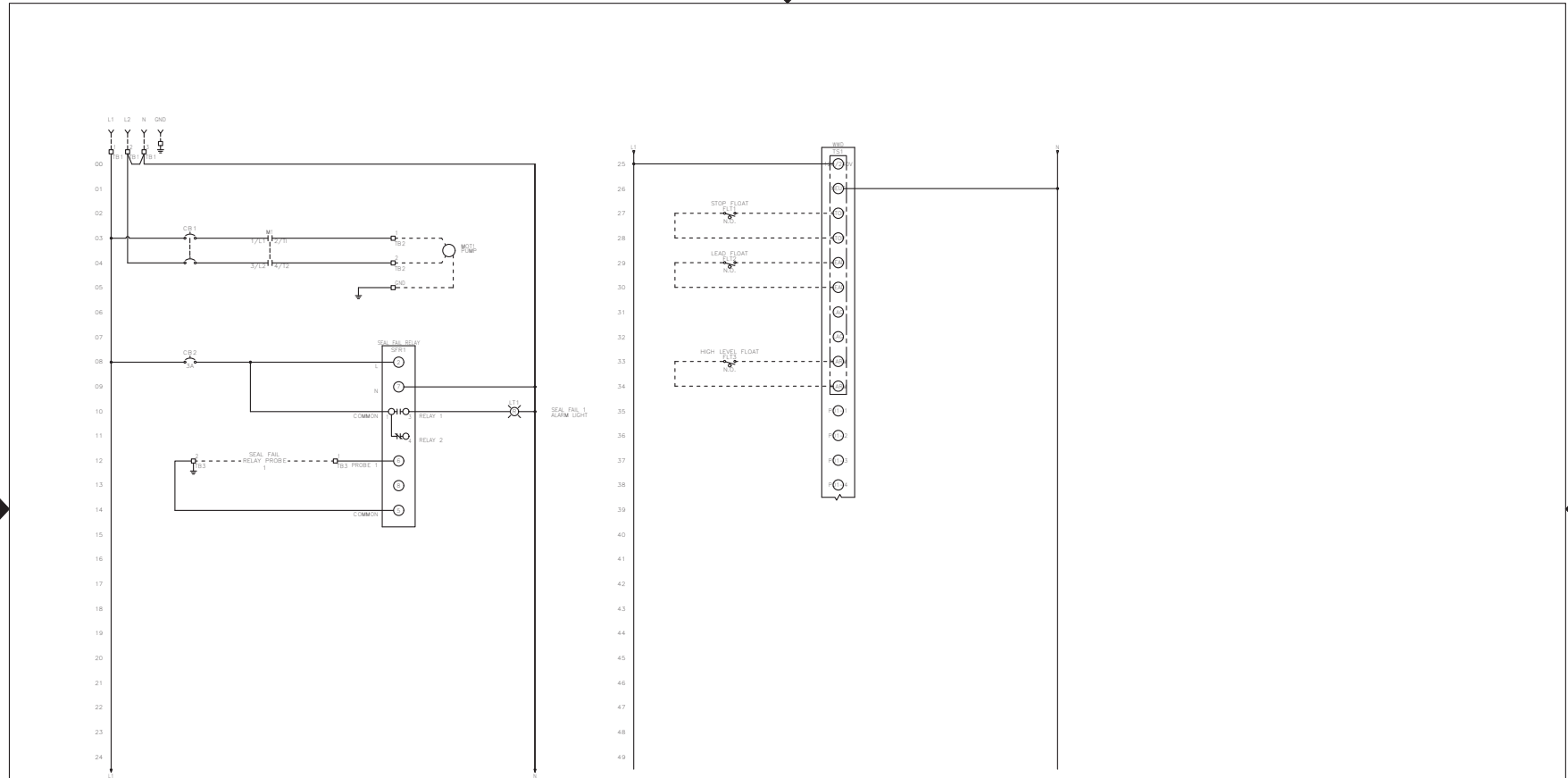

DASHED LINE INDICATES
FIELD WIRING.

USE COPPER CONDUCTORS ONLY.

TEMPERATURE RATING OF CONDUCTORS IS TO BE:
90°C (194°F) FOR UNDER 100A
75°C (167°F) FOR OVER 100A.

BRANCH CIRCUIT PROTECTION SHALL BE PROVIDED BY THE
INSTALLER. MUST BE SIZED ACCORDING TO PUMPMOTOR
MANUFACTURING SPECIFICATIONS.

VERIFY CORRECT OPERATION OF CONTROL PANEL AFTER
INSTALLATION IS COMPLETE.

FIELD WIRING TORQUE SPECS.	
TERMINAL BLOCK UT 2.5	5 IN-LB
TERMINAL BLOCK UT 4	7 IN-LB
TERMINAL BLOCK UT 6	15 IN-LB
TERMINAL BLOCK UT 10	15 IN-LB
TERMINAL BLOCK UT 16	25 IN-LB
TERMINAL BLOCK UT 35	30 IN-LB
TS1, TS2, J2 & J3 PCB	5 IN-LB
TRANSFORMER H1F, H2F & H3F	15 IN-LB
DS1 VLS3P16-63 R1	10 IN-LB
DS1 VLS3PE3-125 R2	18 IN-LB
DS1 LK4JU3CN 100A	45 IN-LB
DS1 LK4MU3N 200A	36 IN-LB
	200 IN-LB

DRAWN BY:	AL	DATE:	05/16/23
APPROVED BY:	DO	DATE:	05/17/23

THIS DRAWING CONTAINS
PROPRIETARY INFORMATION
AND SHALL NOT BE USED
OR DISCLOSED WITHOUT
PRIOR WRITTEN
AUTHORIZATION.

			
TITLE: SDS12228 CONTROL PANEL SCHEMATIC			
SIZE B	DWG NO. 4391	PART NO. SDS12228	REV
SCALE NONE	SHEET 1 OF 2		

CONTROL PANEL SCHEMATIC

GWTSDS12228 R1

FNAME: SDS12228

REVDATE: 0523

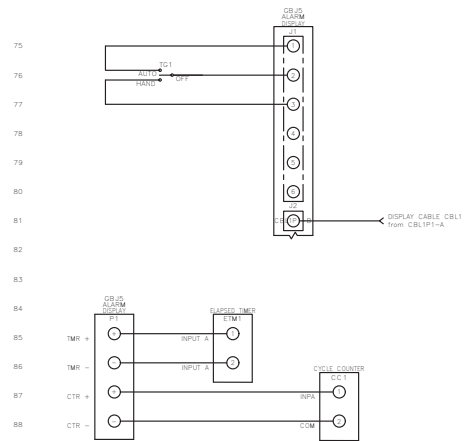
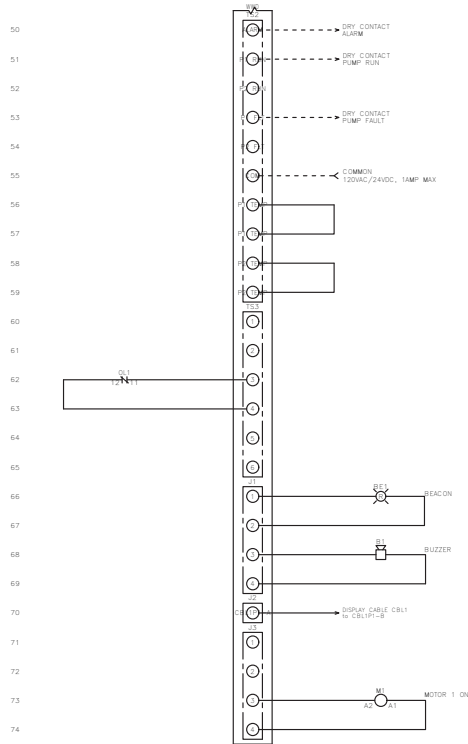

----- DASHED LINE INDICATES FIELD WIRING.

USE COPPER CONDUCTORS ONLY.

TEMPERATURE RATING OF CONDUCTORS IS TO BE: 60°C (140°F) FOR UNDER 100A, 75°C (167°F) FOR OVER 100A.

BRANCH CIRCUIT PROTECTION SHALL BE PROVIDED BY THE INSTALLER; MUST BE SIZED ACCORDING TO PUMP/MOTOR MANUFACTURING SPECIFICATIONS.

VERIFY CORRECT OPERATION OF CONTROL PANEL AFTER INSTALLATION IS COMPLETE.

FIELD WIRING TORQUE SPECS.	
TERMINAL BLOCK UT 2.5	5 IN-LB
TERMINAL BLOCK UT 4	7 IN-LB
TERMINAL BLOCK UT 6	15 IN-LB
TERMINAL BLOCK UT 10	15 IN-LB
TERMINAL BLOCK UT 16	25 IN-LB
TERMINAL BLOCK UT 35	30 IN-LB
TS1, TS2, J2 & J3 PCB	5 IN-LB
TRANSFORMER H1F, H2F & H3F	15 IN-LB
TRANSFORMER H1, H2 & H3	10 IN-LB
DS1 VLS3P16-63 R1	16 IN-LB
DS1 VLS3P63-125 R2	45 IN-LB
DS1 LK4JU3CN 100A	36 IN-LB
DS1 LK4MU3N 200A	200 IN-LB

DRAWN BY: AL DATE: 05/16/23

APPROVED BY: DO DATE: 05/17/23

THIS DRAWING CONTAINS PROPRIETARY INFORMATION AND SHALL NOT BE USED OR DISCLOSED WITHOUT PRIOR WRITTEN AUTHORIZATION.



SDS12228
CONTROL PANEL SCHEMATIC

SIZE B	DWG NO. 4391	PART NO. SDS12228	REV
SCALE NONE	SHEET 2 OF 2		

CONTROL PANEL LAYOUT

GWTSDS12228 R1

FNAME: SDS12228

REVDATE: 0523

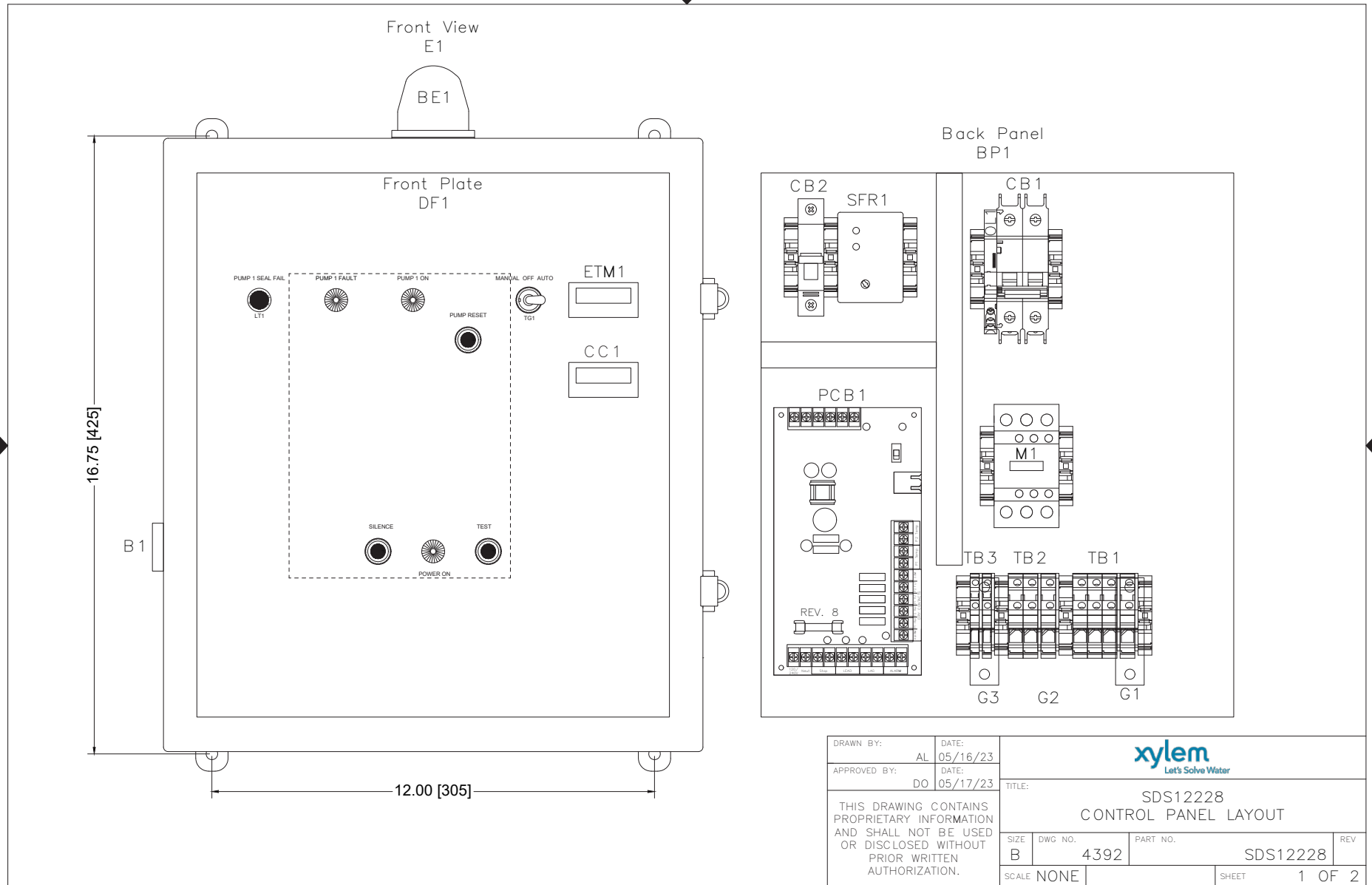

DRAWN BY: AL		DATE: 05/16/23		 Let's Solve Water	
APPROVED BY: DO		DATE: 05/17/23			
THIS DRAWING CONTAINS PROPRIETARY INFORMATION AND SHALL NOT BE USED OR DISCLOSED WITHOUT PRIOR WRITTEN AUTHORIZATION.				TITLE: SDS12228 CONTROL PANEL LAYOUT	
SIZE	DWG NO.	PART NO.	REV		
B	4392	SDS12228			
SCALE NONE			SHEET 1 OF 2		

CONTROL PANEL LAYOUT

FNAME: SDS12228

REVDATE: 0523

QTY	MANUFACTURER	DESCRIPTION	PART NUMBER	REF.
1	Integra	P.C. Nema 4X Enclosure	H161407HCLL	E1
1	All-Spec	Dead Front	519P	DF1
1	All-Spec	Back Panel	525	BP1
1	Integra	Hinge Kit	US0PK-909	N/A
1	Ingram	Beacon	R10-SM	BE1
1	Ingram	Buzzer	PB-024-AD	B1
1	VCC	Red Light 125V	1050QC1	LT1
1	See Water	Display Board	GBJ5	N/A
3	LEDTRONICS	White Lense	LENS-LCD780-CWF	N/A
2	See Water	Flat Cable Assembly	IDC-25MB	N/A
2	Molex	4 Pin Connector	09-50-3041	N/A
1	Molex	6 Pin Connector	09-50-3061	N/A
1	See Water	Power Circuit Board	WWD	PCB1
1	Carling	HOA Toggle Switch	6FC57-73	N/A
1	Schneider	M9 Circuit Breaker	M9F42240	CB1
1	Schneider	Side Mount Auxiliary	M9A26924	OL1
1	Schneider	Contactora	LC1D32JL	M1

QTY	MANUFACTURER	DESCRIPTION	PART NUMBER	REF.
1	Noark	Circuit Breaker 3A 1 Pole	B1E1C3	CB2
1	Macromatics	Seal Fail Single Channel Relay	SFP120A100	SFR1
1	Macromatics	8 Pin Socket	70169-D	SFR1
1	Trumeter	Elapsed Time Meter	6320-2500-0000	ETM1
1	Trumeter	Cycle Counter	6300-2500-0000	CC1
1	Phoenix Contact	Terminal Block UT-4	3044102	TB3
1	Phoenix Contact	Terminal Block UT-4-PE	3044128	G3
5	Phoenix Contact	Terminal Block UT-10	3044160	TB1-2
2	Phoenix Contact	Terminal Block UT-10-PE	3044173	G1-2
11	Phoenix Contact	End Stop	3022218	N/A
6	Phoenix Contact	End Cover	3047028	N/A
2	Altech	Angled Mounting Bracket	CA603	N/A
3	See Water	N.O. Narrow Angle Floats 50'	FPC0N50	N/A
1	UL	508A UL Labels	N/A	N/A

DRAWN BY:	AL	DATE:	05/16/23	 Let's Solve Water			
APPROVED BY:	DO	DATE:	05/17/23				
THIS DRAWING CONTAINS PROPRIETARY INFORMATION AND SHALL NOT BE USED OR DISCLOSED WITHOUT PRIOR WRITTEN AUTHORIZATION.				TITLE:			
				SDS12228 CONTROL PANEL LAYOUT			
				SIZE	DWG NO.	PART NO.	REV
B	4392	SDS12228					
SCALE	NONE	SHEET	2 OF 2				



Xylem Inc.
 2881 East Bayard Street Ext.
 Seneca Falls, NY 13148
 Phone: (800) 453-6777
 Fax: (888) 322-5877
www.xylem.com/goulds