

Additional Installation, Operation and
Maintenance Instructions

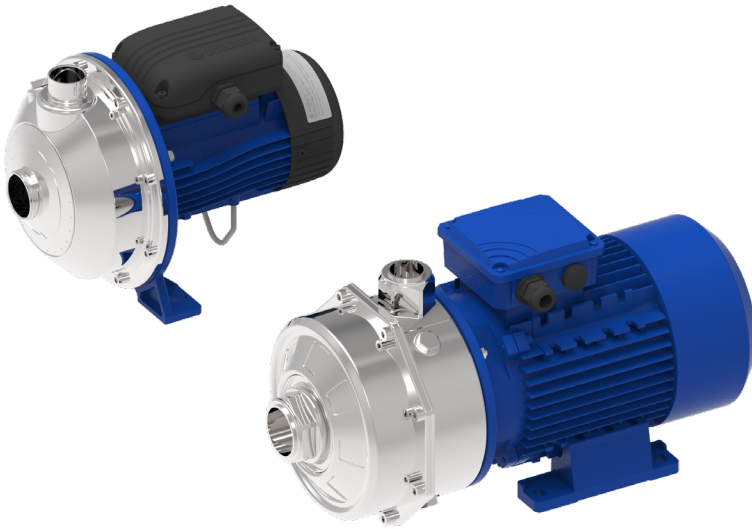

GCEA, GCIE, GCA Series

Single and twin impeller close-coupled
centrifugal electric pumps

Table of Contents

- 1 Introduction and Safety 4
 - 1.1 Introduction 4
 - 1.2 Hazard levels and safety symbols..... 4
 - 1.3 User safety 6
 - 1.4 Protection of the environment..... 6
- 2 Handling and storage 7
 - 2.1 Precautions 7
 - 2.2 Unit inspection upon delivery..... 8
 - 2.2.1 Package inspection 8
 - 2.2.2 Unpacking and inspection of the unit 8
 - 2.3 Lifting and positioning the unit..... 8
 - 2.4 Storage 9
- 3 Product Description 11
 - 3.1 Features 11
 - 3.1.1 Use in water distribution networks for human consumption 12
 - 3.2 Part names 13
 - 3.3 Data plate 15
 - 3.4 Identification code 16
 - 3.5 Liquid temperature plate 16
- 4 Mechanical installation 18
 - 4.1 Precautions 18
 - 4.2 Installation area 19
 - 4.3 Requirements on the concrete foundation 20
 - 4.4 Permitted positions 20
 - 4.5 Fastening 20
 - 4.6 Reducing vibrations 20
 - 4.7 Environments prone to condensation 21
- 5 Hydraulic connection 22
 - 5.1 Preliminary operations 22
 - 5.2 Guidelines for the suction side 22
 - 5.2.1 Positive suction head installation 23
 - 5.2.2 Suction lift installation 24
 - 5.3 Guidelines for the discharge side 25
- 6 Electrical connection..... 26
 - 6.1 Guidelines for electrical connection 26
 - 6.2 Guidelines for the control panel..... 26
 - 6.3 Motor connection 26
 - 6.4 Operation with frequency converter 27

7	Use and operation	28
7.1	Precautions	28
7.2	Filling and priming	29
7.3	Checking the direction of rotation (three-phase motor)	30
7.3.1	Wrong rotation direction (three-phase motor)	30
7.4	Startup	30
7.5	Stopping the unit.....	32
8	Maintenance.....	33
8.1	Precautions	33
8.2	Maintenance every 4000 hours of operation, or every year	33
8.3	Maintenance every 10000 hours of operation or every 2 years	33
8.4	Maintenance every 17500 hours of operation or every 5 years	33
8.5	Long periods of inactivity.....	34
8.6	Identification of spare parts	34
9	Troubleshooting.....	35
9.1	The unit does not switch on	35
9.2	Little or no hydraulic performance	35
9.3	The unit starts and stops too frequently.....	36
9.4	The unit produces excessive noise and/or vibrations	36
9.5	The unit is leaking at the mechanical seal.....	37
9.6	The motor becomes excessively hot	37
9.7	Tripping of the thermal motor protection.....	37
9.8	The residual current protection device (RCD) has tripped	37
10	Specifications	38
10.1	Operating environment	38
10.2	Operating temperature and pressure	38
10.3	Maximum head.....	39
10.3.1	GCEA and GCIE series	39
10.3.2	GCA series	40
10.4	Maximum number of starts and stops.....	40
10.5	Electrical specifications	40
10.6	Sound pressure	40
10.7	Materials in contact with the liquid	41
11	Disposal.....	42
11.1	Precautions	42
11.2	WEEE (EU/EEA)	42
11.3	WEEE (UK)	43
12	Declarations	44
12.1	Electric pump	44
12.2	Pump unit (electric pump) (UKCA)	46
13	Warranty.....	48

1 Introduction and Safety

1.1 Introduction

Purpose of this manual

This manual provides information on how to do the following in the correct manner:

- Installation
- Operation
- Maintenance.

Supplementary instructions



The instructions and warnings of this manual apply to the standard electric pump (hereinafter unit) as described in the sale documentation. Special version pumps may be supplied with supplementary instruction manuals. For situations not considered in the manual or in the commercial documentation, contact Xylem or the Authorised Distributor.

1.2 Hazard levels and safety symbols







Before using the unit, the user must read, understand and comply with the indications of the danger warnings in order to avoid the following risks:

- Injuries and health hazards
- Damage to the product
- Unit malfunction.

Hazard levels

Hazard level	Indication
 DANGER:	It identifies a dangerous situation which, if not avoided, causes serious injury, or even death.
 WARNING:	It identifies a dangerous situation which, if not avoided, may cause serious injury, or even death.
 CAUTION:	It identifies a dangerous situation which, if not avoided, may cause small or medium level injuries.
NOTE:	It identifies a situation which, if not avoided, may cause damage to property but not to people.

Complementary symbols

Symbol	Description
	Electrical hazard
	Hot surface hazard
	Danger, pressurized system
	Explosive atmosphere hazard
	Ionizing radiation hazard
	Danger, suspended loads
	Danger from heavy manual loads
	Hot liquid danger
	Do not use flammable liquids
	Obligation to read the instruction manual
	Obligation to wear safety shoes
	Obligation to wear safety glasses
	Obligation to wear a safety helmet
	Obligation to wear safety gloves

1.3 User safety

Strictly comply with current health and safety regulations.

Qualified personnel



WARNING:

The installation, operation, maintenance and troubleshooting of the unit are reserved for qualified personnel only. Qualified personnel are persons who are able to recognise risks and avoid dangers during these operations.

Inexperienced users



WARNING:

- For EU countries: this product may be used by children aged 8 years and above and persons with reduced physical, sensory or mental capabilities, or who lack experience and knowledge, provided that they are being supervised and have been instructed on how to use it safely, and understand the hazards involved. Children must not play with the product. Cleaning and maintenance must not be carried out by children without supervision.
 - For countries outside the EU: this product is not intended for use by persons (including children) with reduced physical, sensory or mental capabilities, or who lack experience and knowledge, unless they are being supervised and have been instructed on how to use it by a person responsible for their safety. Children should be supervised to ensure that they do not play with the product.
-

Personal protective equipment



WARNING:

Always wear personal protective equipment.

Sites exposed to ionizing radiations



WARNING: Ionizing radiation hazard

If the unit has been exposed to ionizing radiations, implement the necessary safety measures for the protection of people. If the unit needs to be dispatched, inform the carrier and the recipient accordingly, so that appropriate safety measures can be put in place.

1.4 Protection of the environment

Disposal of packaging and product

Comply with the current regulations on sorted waste disposal, see **Disposal**.

Leaking of fluid

If the unit contains lubricating fluid, take appropriate measures to prevent the dispersion of leaks into the environment.



WARNING:

It is prohibited to dispose of lubricating fluids and other hazardous substances in the environment.

2 Handling and storage

2.1 Precautions

Before starting any work, make sure to read and understand all the safety instructions in **Introduction and Safety**.



DANGER: Electrical hazard

Before starting work, check that the electric power supply is disconnected and locked out, to avoid unintentional restart of the unit, the control panel and the auxiliary control circuit.

Handling and positioning the unit



WARNING: Crushing hazard

The unit and components are heavy: risk of crushing.



WARNING: Danger from heavy manual loads

Check the gross weight on the packaging before handling the unit.



WARNING: Danger from heavy manual loads

Check the net weight on the nameplate before handling the unit.



WARNING: Danger from heavy manual loads

Handle the unit in compliance with the current regulations on "manual load handling", to avoid undesirable ergonomic conditions causing risks of back-spine injury.



WARNING:

Take appropriate measures during transport, installation and storage to prevent contamination from external substances.



WARNING:

Use ropes, cords, hooks and/or carabiners (hereinafter referred to as "hooks") that comply with current directives and are suitable for the specific task.



WARNING:

Lift and handle the unit slowly to avoid stability issues.



WARNING:

During handling, make sure to avoid injury to people and animals, and/or damage to property.

NOTE:

Make sure that the harnessing does not hit and/or damage the unit.

2.2 Unit inspection upon delivery

2.2.1 Package inspection

1. Check that quantity, descriptions and product codes match the order.
2. Check the packaging for any damage or missing components.
3. In case of immediately detectable damage or missing parts:
 - Accept the goods with reserve, indicating any findings on the transport document, or
 - Reject the goods, indicating the reason on the transport document.In both cases, promptly contact Xylem or the Authorised Distributor from whom the product was purchased.

2.2.2 Unpacking and inspection of the unit

1. Remove the packaging.
2. Ensure sorting of all packaging materials in accordance with the applicable regulations.
3. Free the unit by removing any straps.
4. Check the unit for integrity and to make sure that there are no missing components.
5. In case of damage or missing components, promptly contact Xylem or the Authorised Distributor.

2.3 Lifting and positioning the unit

1. Make two tie-down slings around the unit with two ropes.
2. Fix the two ropes to the crane.
3. Slowly lift and move the unit.
4. Set the unit down slowly.
5. Release the harness.

The figure shows how to harness and lift the unit for GCEA and GCIE models.

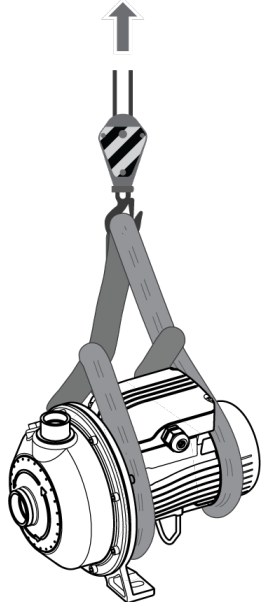

CA_CEA_M002_A_ds

The figure shows how to harness and lift the unit for GCA models.

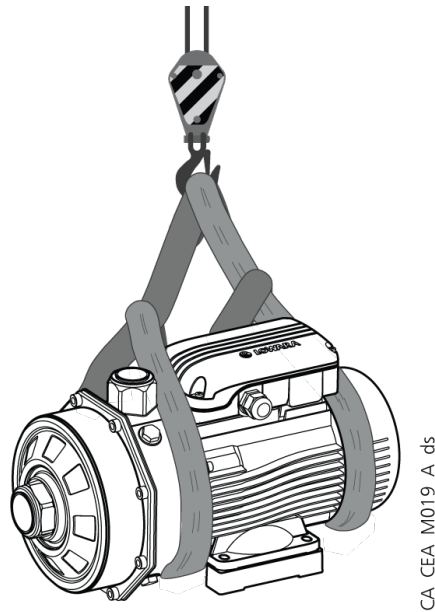

CA_CEA_M019_A_ds

2.4 Storage

Storage of the packed unit

NOTE:

Do not place heavy loads on top of the unit.

NOTE:

Protect the unit from collisions.

The unit must be stored:

- In a covered and dry place
- Away from heat sources
- Protected from dirt
- Protected from vibrations
- At an ambient temperature between -5°C and $+40^{\circ}\text{C}$ (23°F and 140°F), and relative humidity between 5% and 95%.

Long-term storage of the installed unit

1. Empty the unit by removing the drain plug.

The figure shows the position of the drain plug for GCEA models.

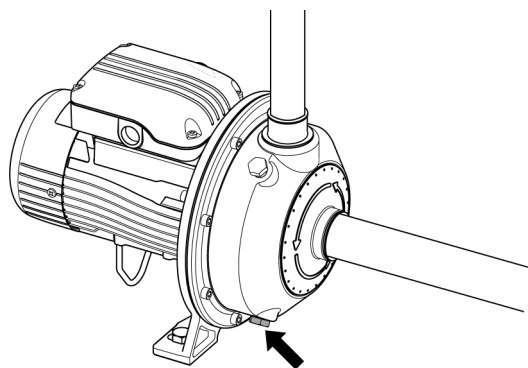

CA_CEA_M003_A_ds

The figure shows the position of the drain plug for GCA models.

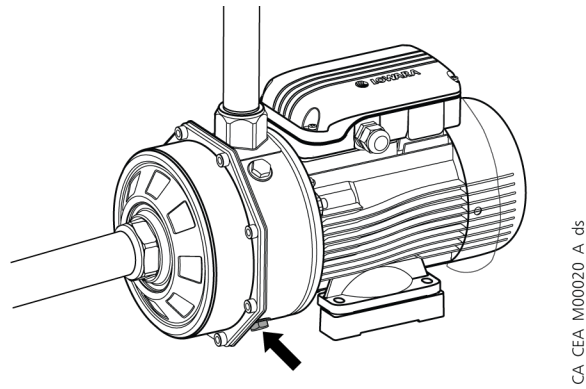

This operation is essential in environments with cold temperatures. Otherwise, any residual liquid in the unit could have an adverse effect on its condition and performance.

2. For storage periods longer than 5 years, check:
 - The electrical condition of the capacitor (if present)
 - The integrity of the elastomers inside the unit. Replace them if damaged or worn
3. When starting the unit for the first time after an extended storage period, check for any leakage due to wear of the elastomers caused by inactivity.

For more information on long-term storage contact the Xylem sales company or Authorised Distributor.

3 Product Description

3.1 Features

Designation of standard models

Series	Name
GCEA	Stainless steel single-impeller close-coupled centrifugal electric pump.
GCA	Double impeller horizontal close-coupled centrifugal electric pump.

Designation of special versions

Model	Name
GCIE	GCEA series electric pump, for use in HVAC applications.
GCA..V, GCA..N	GCA series electric pump, for dedicated use.
GCEA..V/GCEA..N:	GCEA series electric pump, for dedicated use.

Intended use

- Transfer of clean, non-aggressive water, free of dissolved gases
- Pressure boosting and water supply systems
- Washing and cleaning industry
- Circulation of hot and cold liquids, for example water or water & glycol, for heating, cooling and air conditioning systems
- Water treatment applications
- Transfer of moderately chemically aggressive liquids
- Irrigation

Observe the operating limits in **Specifications**.

For other applications, contact Xylem or the Authorised Distributor.



DANGER: Potentially explosive atmosphere hazard

It is prohibited to start the unit in environments with potentially explosive atmospheres or with combustible dusts.

Pumped liquids

- Cold water
- Hot water
- Clean
- Chemically and mechanically non aggressive.

Contact Xylem or the Authorised Distributor for other liquids.



DANGER:

It is prohibited to use this unit to pump flammable and/or explosive liquids.

NOTE:

When using liquids with a density and/or viscosity higher than that of water, such as a mixture of water and glycol, contact Xylem or the Authorised Distributor to check whether a motor with a higher power rating is required.

NOTE:

When using chemically treated water (softened, deionised, demineralised, etc.) and for any situation other than those described in the liquid type, please contact Xylem or the Authorised Distributor.

3.1.1 Use in water distribution networks for human consumption

If the unit is intended for water supply to people and/or animals:



WARNING:

It is prohibited to pump drinking water after use with other fluids.



WARNING:

Take appropriate measures during transport, installation and storage to prevent contamination from external substances.



WARNING:

Remove the unit from its packaging just before installation to prevent contamination from external substances.



WARNING:

After installation, run the unit for a few minutes with several users open in order to wash the inside of the system.

3.2 Part names

GCEA series

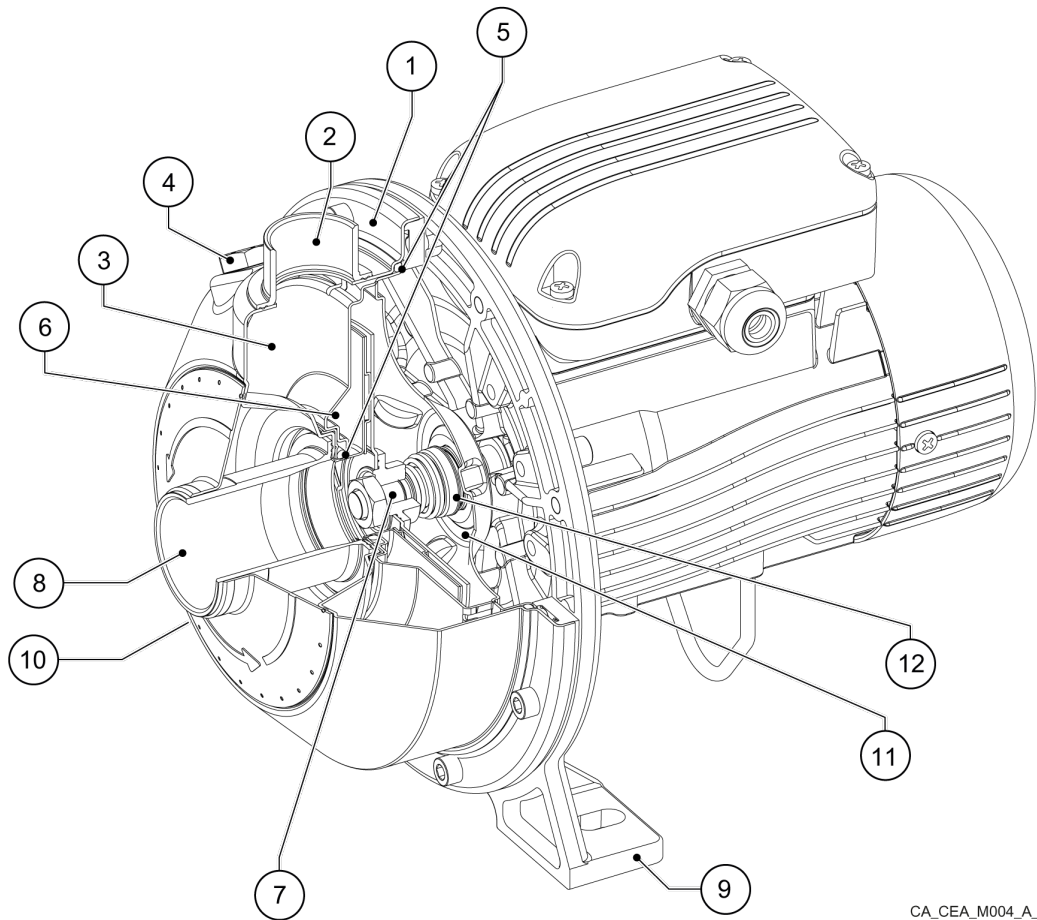

CA_CEA_M004_A_ds

1. Pump body
2. Discharge port
3. Diffuser
4. Filling plug
5. Elastomers
6. Impeller
7. Shaft
8. Suction port
9. Motor adapter with attachments
10. Drain plug
11. Seal housing
12. Mechanical seal

GCA series

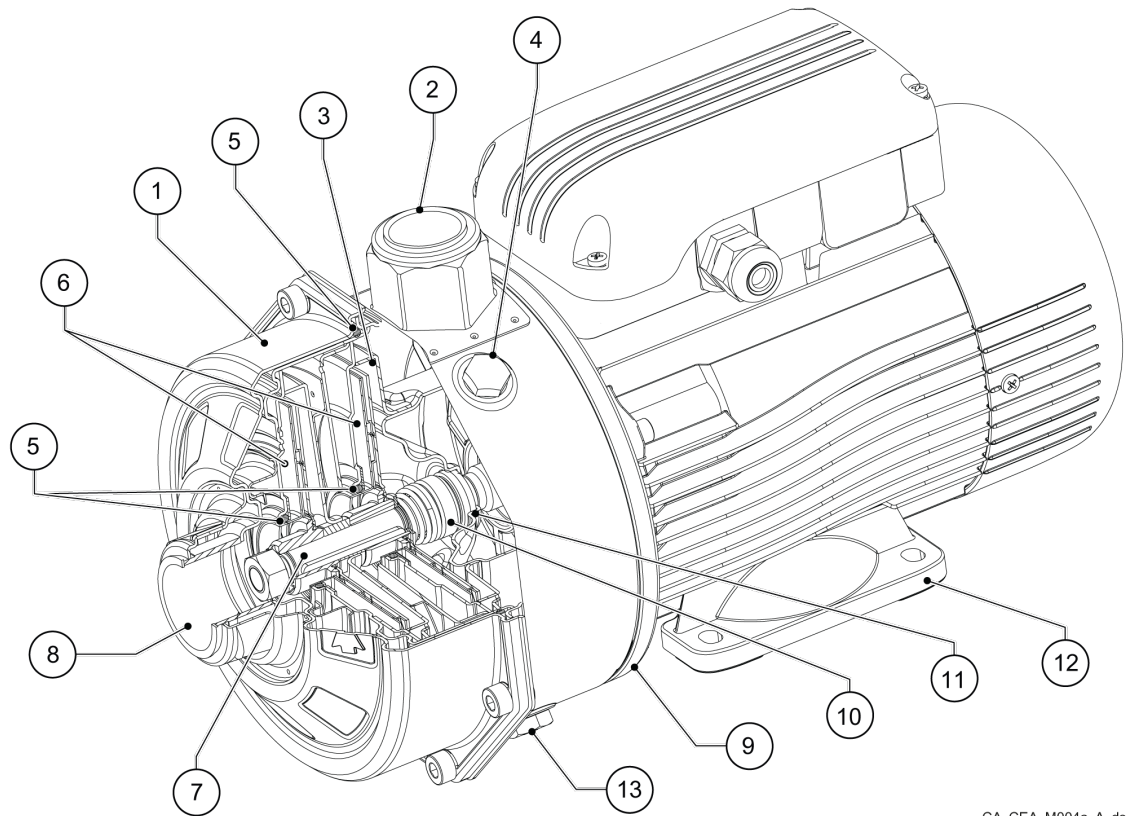

CA_CEA_M004a_A_ds

1. Pump body
2. Discharge port
3. Diffuser
4. Filling plug
5. Elastomers
6. Impeller
7. Shaft
8. Suction port
9. Motor adapter
10. Mechanical seal
11. Seal housing
12. Supporting foot
13. Drain plug

3.3 Data plate

The figure shows the position of the data plate based on model.

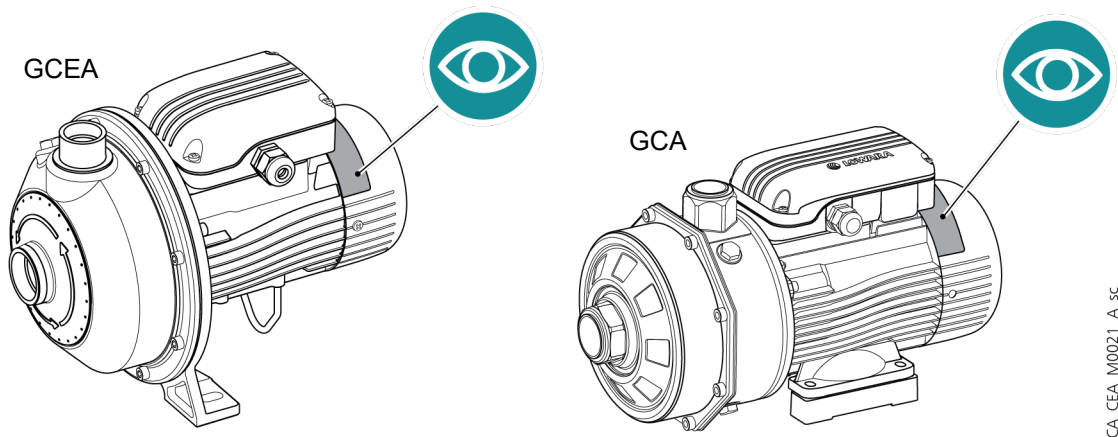

CA_CEA_M0021_A_sc

The figure shows the data plate with single-phase motor.

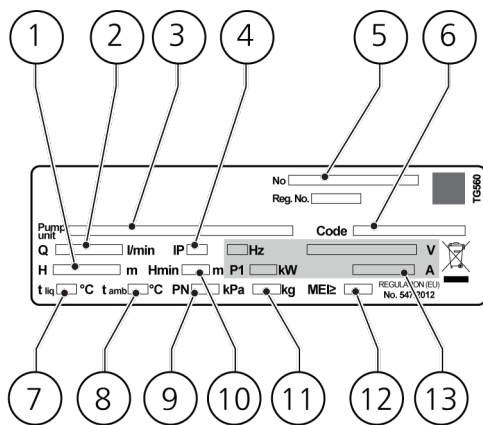

CA_CEA_M005m_B_sc

The figure shows the data plate with three-phase motor.

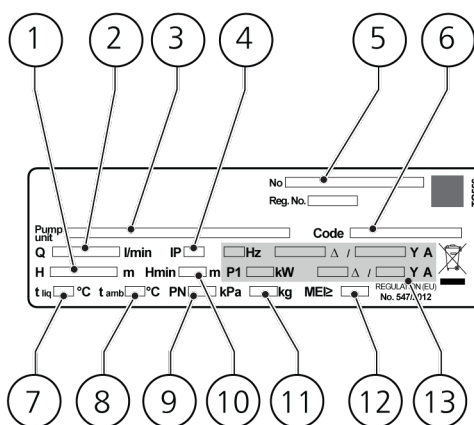

CA_CEA_M0005t_B_sc

1. Head range
2. Flow rate range
3. Identification code
4. Protection degree of the unit
5. Serial number (date+progressive number)
6. Product code
7. Maximum operating temperature of the liquid (for usage in compliance with EN 60335-2-41)
8. Maximum temperature of the ambient of use

9. Maximum operating pressure
10. Minimum head (EN 60335-2-41)
11. Weight
12. Minimum efficiency index (MEI)
13. Electrical data

3.4 Identification code

GCEA series

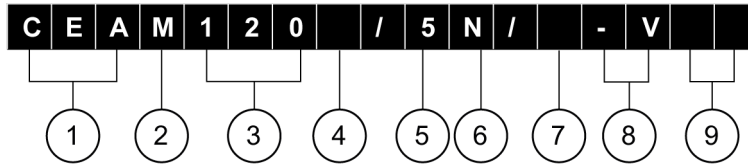

CA_CEA_M0016_A_sc

1. CEA, CIE series name
2. Phase [] = three-phase, [M] = single-phase
3. Nominal flow rate in l/min
4. Frequency [6] = 60 Hz, [] = 50 Hz
5. Impeller size, dimensionless value
6. Material [] = AISI 304 version, N = AISI 316 (CEA ..N) version, V = Victaulic® connections
7. Motor efficiency level [A] = IE2 three-phase version, [D] = IE3 three-phase version, [C] = IE2 single-phase version
8. Elastomer material [] = NBR gaskets for CEA, EPDM gaskets for CEA..N and CIE, [V] = FKM gaskets
9. Extra description [] = standard version, letter assigned by the manufacturer

GCA series

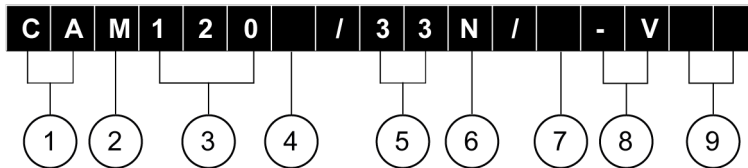

CA_CEA_M0016a_A_sc

1. CA series name
2. Phase [] = three-phase, [M] = single-phase
3. Nominal flow rate in l/min
4. Frequency [6] = 60 Hz, [] = 50 Hz
5. Impeller size, dimensionless value
6. Material [] = AISI 304 (CA) version, N = AISI 316 (CA ..N) version
7. Motor efficiency level [D] = IE3 three-phase version, [C] = IE2 single-phase version
8. Elastomer material [] = NBR gaskets for CA, EPDM gaskets for CA..N, [V] = FPM gaskets for CA, CA..N
9. Extra description [] = standard version, letter assigned by the manufacturer

3.5 Liquid temperature plate

The figure shows the position of the liquid temperature data plate based on model.

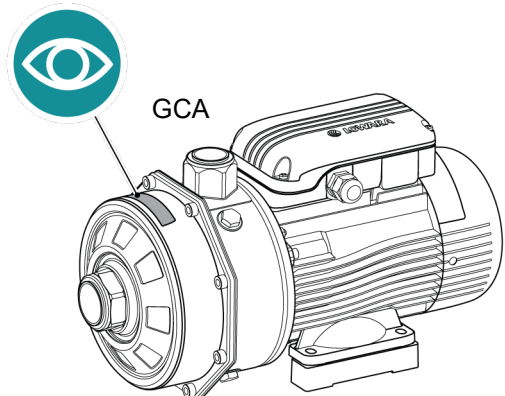
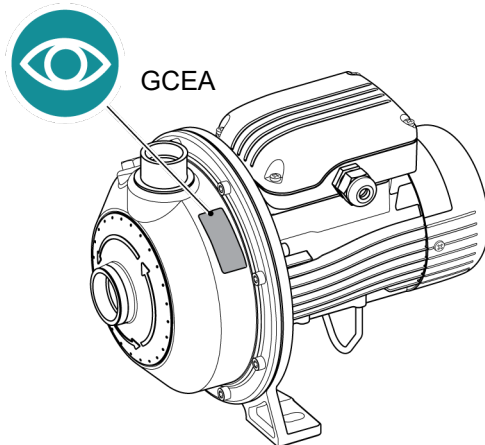

CA_CEA_M0028_A_sc

It is applied on the units where the maximum working temperature of the liquid exceeds the limit of 110°C (230°F), foreseen by the EN 60335-2-41 standard, with U_n (V) \leq 480 V (3~) or \leq 250 V (1~).

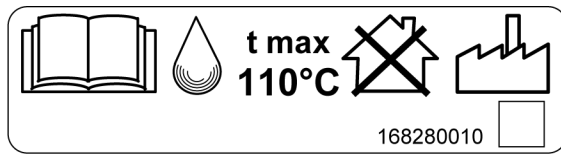

CA_CEA_M0027_A_sc

4 Mechanical installation

4.1 Precautions

General precautions

Before starting any work, make sure to read and understand all the safety instructions in **Introduction and Safety**.



WARNING:

Always use suitable working tools.



WARNING:

When selecting the place of installation and connecting the unit to the hydraulic and electric power supplies, strictly comply with current regulations.

When connecting the unit to a public or private aqueduct, or when placing it into a well for the supply of water for human and/or animal consumption, see **Use in water distribution networks for human consumption**.



WARNING:

Piping must be sized to ensure safety at the maximum operating pressure.



WARNING:

Install appropriate gaskets between the unit and the piping system.

Electrical measures



DANGER: Electrical hazard

Before starting work, check that the electric power supply is disconnected and locked out, to avoid unintentional restart of the unit, the control panel and the auxiliary control circuit.



WARNING:

The absorbed current must be below the rated limits. Refer to the values on the data plate.

NOTE:

The mains voltage and frequency must match the specifications on the data plate.

NOTE:

Before starting work, make sure that the general electric requirements and/or those of the firefighting systems (hydrants or sprinklers) comply with local regulations.

Ground



DANGER: Electrical hazard

1) Always connect the external protection conductor (ground) to the ground terminal before attempting to make any other electrical connections. 2) Connect all the electrical accessories of the unit to the ground. 3) Check that the external protection conductor (ground) is longer than the phase conductors. In case of accidental disconnection of the unit from the phase conductors, the protection conductor must be the last one to detach itself from the terminal. 4)

Install suitable systems for protection against indirect contact, in order to prevent lethal electric shocks.

4.2 Installation area

1. Install the unit on a concrete or metal foundation base sufficiently strong to ensure permanent and rigid support, see **Requirements on the concrete foundation**.
2. Follow the provisions in **Operating environment**.
3. Place the unit in a raised position in relation to the floor.
4. Install the unit in an accessible location.
5. Leave sufficient space around the unit to allow for operation and maintenance.
6. Make sure that any leaks will not cause flooding to the installation area or submerge the unit.
7. In case of outdoor installation, ensure appropriate protection of the unit against:
 - direct sunlight
 - atmospheric agents

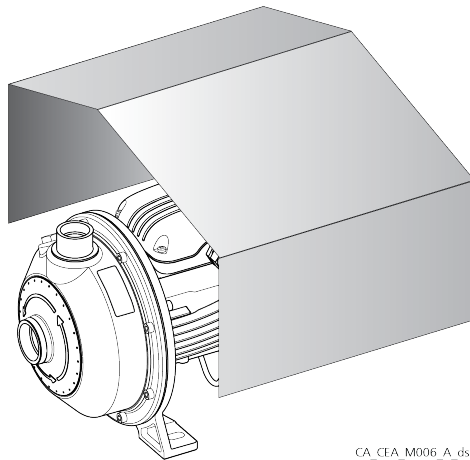

CA_CEA_M006_A_ds

Air clearance between a wall and the external surfaces of the unit



WARNING:

Observe the distances indicated for ventilation of the unit and to allow for any operations on the motor, see the figure below.

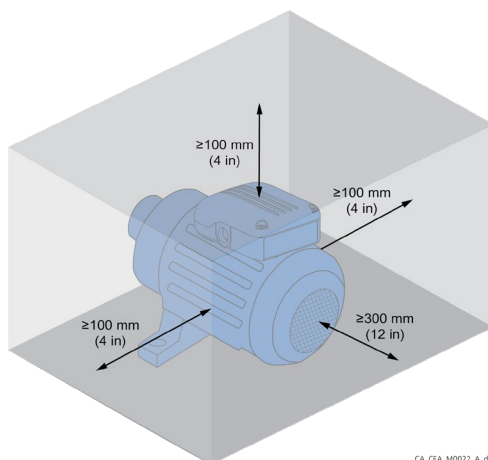

CA_CEA_M0022_A_ds

If there is less space available, please contact Xylem or the Authorised Distributor.

4.3 Requirements on the concrete foundation

- The concrete must have a compression resistance of C12/15 and meet the requirements of exposure class XC1 according to EN 206-1
- The foundation weight must be ≥ 1.5 times the unit weight (≥ 5 times the weight of the unit if a quieter operation is required)
- The surface should be as flat and level as possible.

4.4 Permitted positions

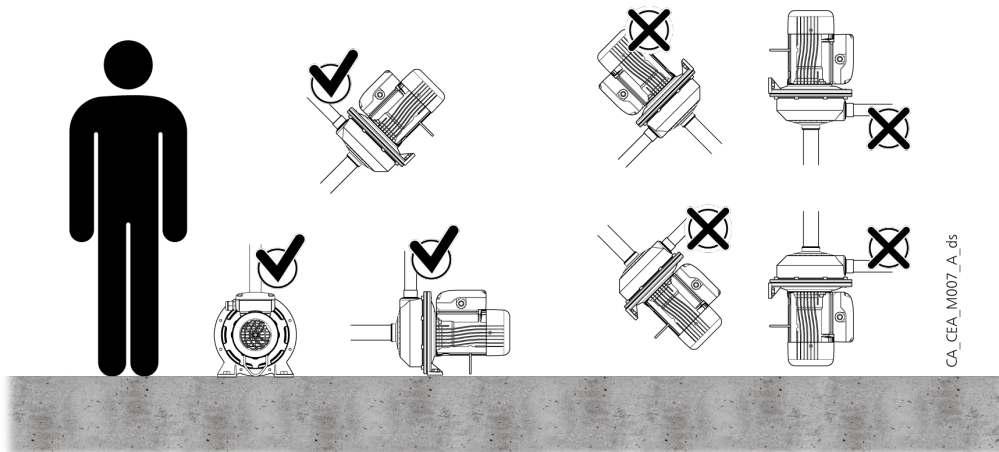

CA_CEA_M007_A_gs

4.5 Fastening

1. Place the unit on the foundation.
2. Using a spirit level, make sure that the unit is level.
3. Align the suction and discharge ports to their piping.
4. Secure the unit with bolts (2 or 4, depending on model).
5. If present, remove the plugs covering the suction and discharge ports.

The figure shows how to install the unit depending on the model.

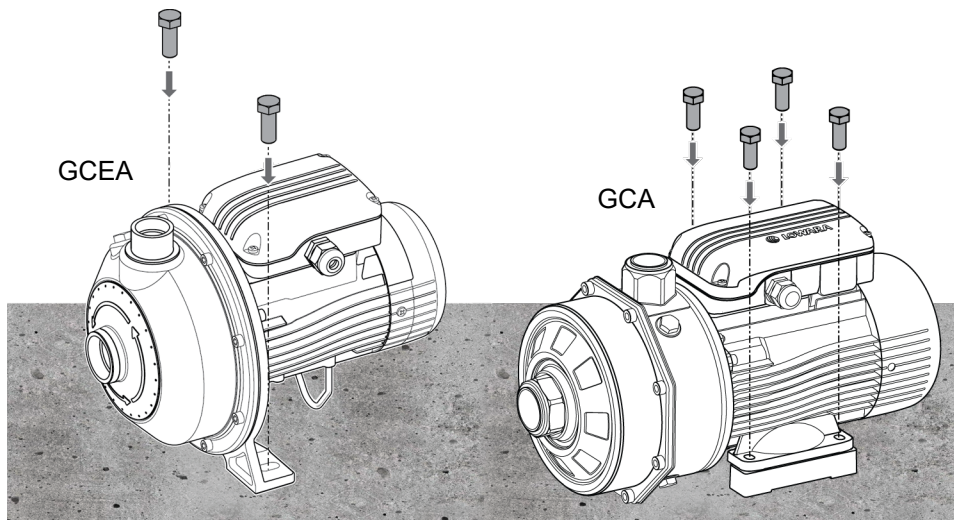

CA_CEA_M0018_A_sc

4.6 Reducing vibrations

The motor and the flow of liquids in the system can generate amplified vibrations from the possible incorrect installation of the unit and the piping. See **Hydraulic connection**.

4.7 Environments prone to condensation

If the ambient temperature is higher than the liquid temperature, condensation may form inside the motor during idle periods. To prevent the accumulation of condensation, open the drain plug.

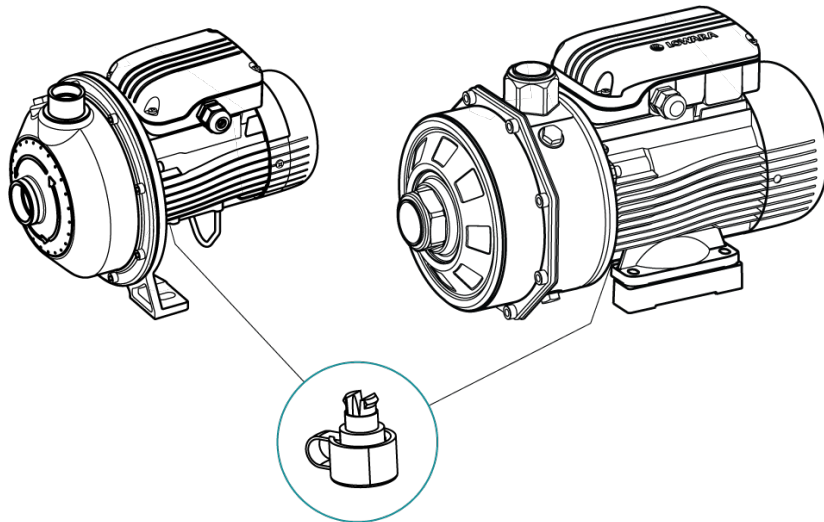

CA_CEA_M023_A_ds

NOTE:

If the plug is opened, the motor protection class becomes IP4X.

Thermal insulation

Do not cover the motor adapter with thermal insulators so as not to trap the vapours released by the mechanical seal, which can cause corrosion.

5 Hydraulic connection

5.1 Preliminary operations

1. Flush the piping system before connecting them to the unit, to remove any welding residue, deposits and impurities.
2. If a lifting device is used, for example a sling bar or hoist, provide sufficient space above the unit.
3. Check the maximum operating pressure of piping system, joints, valves and expansion vessels, which must be higher than the maximum pressure delivered by the unit on the discharge side.
4. Do not install the unit at the lowest point of the system, to avoid the accumulation of sediments.
5. Install an automatic relief valve at the highest point of the system to eliminate air bubbles.
6. If several units are used with the same liquid source, provide a suction pipe for each unit.
7. Support the piping system independently, so as not to burden the unit.
8. Install a prevention device to protect against the lack of liquid (float or probes) or a minimum pressure device (pressure switch).
9. To reduce the transmission of vibrations between the unit and the system and vice versa, install:
 - anti-vibration joints on the suction and discharge sides of the unit; alternatively use flexible pipes
 - dampers between the unit and the surface on which it is installed.

5.2 Guidelines for the suction side

To reduce friction loss, the piping must be:

- As short and as straight as possible
- Without bottlenecks
- At least six times as long as the diameter of the suction port for the section connected to the unit
- Wider than the suction port; if necessary, install an eccentric reducer with horizontal top surface
- Without bends: if this cannot be avoided, with a radius as wide as possible
- Without traps and 'goosenecks'
- With valves with a low specific friction loss.

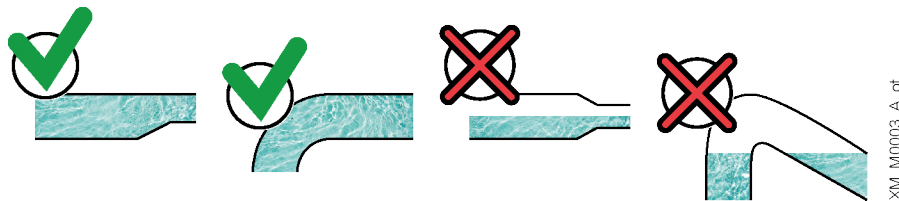

5.2.1 Positive suction head installation

The installation is a positive suction head installation when the unit is below the suction water source.

The figure shows an example of positive suction head installation.

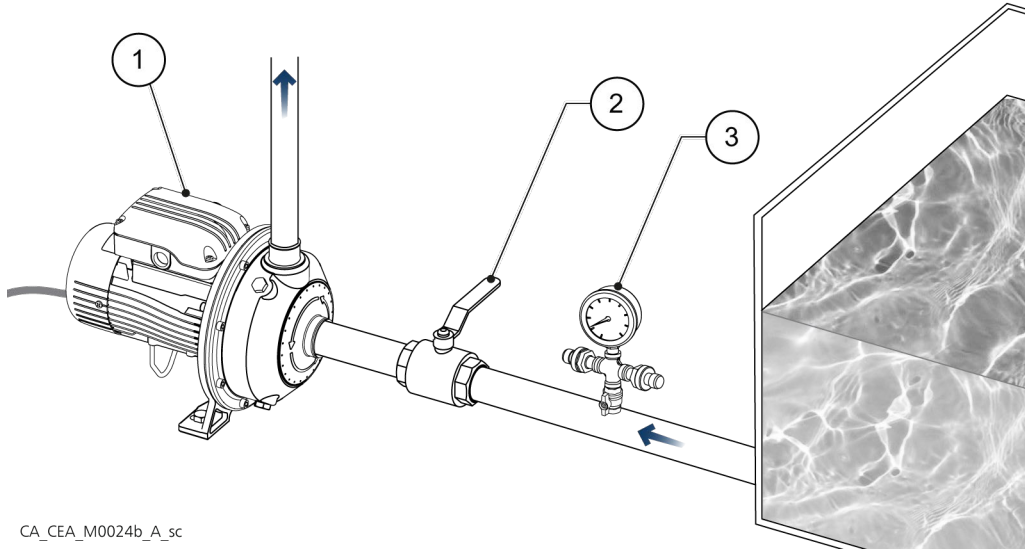

CA_CEA_M0024b_A_sc

Position number	Name	Function
1	Unit	
2	On-off valve	Isolate the unit in case of maintenance
3	Pressure gauge with pressure sensor (if fitted) and shut-off valve	

5.2.2 Suction lift installation

The installation is a suction lift installation when the unit is above the suction water source. The figure shows an example of suction lift installation.

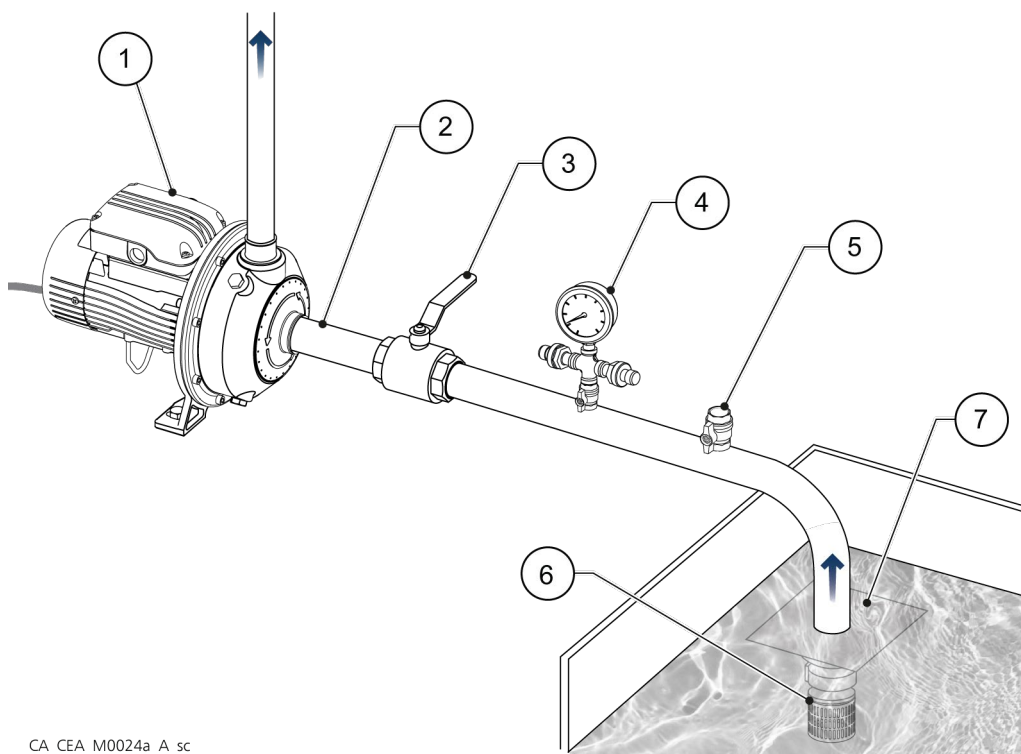

CA_CEA_M0024a_A_sc

Position number	Name
1	Unit
2	Piping system with increasing slope towards the unit exceeding 2% to avoid air pockets
3	On-off valve, to isolate the unit in case of maintenance
4	Hand-vacuum meter with pressure sensor (if fitted) and on-off valve, to also measure the negative operating pressure
5	Fill and relief valve
6	Foot valve and large-mesh filter
7	Vortex protection device, to prevent air from entering during the suction phase

Indicative values of the suction level difference

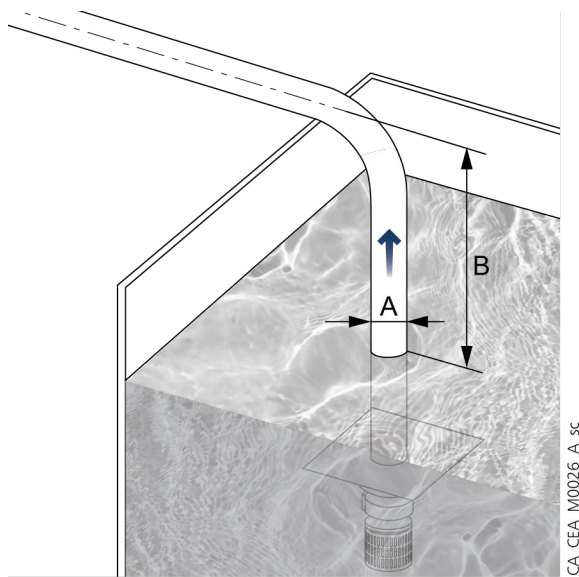

Model	A - Minimum suction pipe diameter, GAS inches	B - Suction level difference, m (ft)	
		With 50% flow rate	With 100% flow rate
GCEA 70	1" 1/4	6 (20)	4 (13)
GCEA 80	1" 1/4	5.5 (18)	3 (10)
GCEA 120	1" 1/4	5 (16)	1.5 (5)
GCEA 210	1" 1/2	5 (16)	1.5 (5)
GCEA 370	2"	5.5 (18)	0.5 (2)
GCA 70	1" 1/4	6.5 (21)	3 (10)
GCA 120	1" 1/4	6 (20)	2.5 (8)
GCA 200	1" 1/2	7.5 (25)	5 (16)

Note

Level difference values calculated using a piping system:

- Total length 10 m for 50% flow rate and 5 m for 100% flow rate
- With a single 90° bend
- With a foot valve.

5.3 Guidelines for the discharge side

On the discharge side install:

- A check valve to prevent the liquid from flowing back into the unit when this is at a standstill
- A pressure gauge fitted with an on-off valve, after the non-return valve, to check the actual operating pressure of the unit
- A pressure sensor after the non-return valve, equipped with an on-off valve, in case of constant pressure operation
- An expansion vessel after the non-return valve, equipped with an on-off valve
- A shut-off valve at the end of the system to isolate the unit in case of maintenance and to regulate the flow rate.

6 Electrical connection

6.1 Guidelines for electrical connection

1. Check that the electrical leads are protected against:
 - High temperature
 - Vibrations
 - Collisions
 - Liquids.
2. Check that the power supply line is provided with:
 - A short circuit protection device of appropriate size
 - A mains disconnection device with contact opening distance ensuring complete disconnection for overvoltage III category conditions.

6.2 Guidelines for the control panel

NOTE:

The control panel must match the ratings on the unit data plate. Improper combinations could damage the motor.

1. Fit a system for protection against dry running to which to connect a pressure switch, or a float, probes or other suitable devices.
2. On the suction side install:
 - A pressure switch, in the case of connection to the mains water supply
 - A float switch or probes, in the case of liquid drawn from a tank or basin.
3. When thermal relays are used, the type sensitive to phase failure is recommended.
4. Install a suitable device (thermal relay or motor protector, see table below) to protect the motor from overloads and short circuits:

Unit type	Protection
Single phase standard ≤ 1.5 kW	<ul style="list-style-type: none"> • Automatic reset thermal-ampere protection, in-built (motor protector) • Short circuit, must be supplied by the installer.¹
Three-phase and single-phase ²	<ul style="list-style-type: none"> • Thermal, must be supplied by the installer • Short circuit, must be supplied by the installer.

NOTE:

Refer to the current shown on the data plate for the selection of the protective device and comply with local and national regulations for its sizing.

6.3 Motor connection



WARNING: Injuries hazard

The unit, equipped with a single-phase motor with automatic reset thermal overload protection, could restart inadvertently after it has cooled down: risk of physical injury.

1. Open the terminal box cover.
2. Connect the power supply conductor; see the figure below or the wiring diagram shown inside the terminal box cover.
3. Connect the protection conductor (ground), making sure that it is longer than the phase conductors.

¹ Fuses aM (motor starting), or magneto-thermal switch with curve C and $I_{cn} \geq 4.5$ kA or other equivalent device.

² Trip class 10 A overload thermal relay + aM fuses (motor start), or start class 10 A motor protection thermal magnetic switch.

4. Connect the phase leads.
5. Close the terminal box cover and tighten all the screws and cable glands.

The figure shows the terminal box types and the electrical connection.

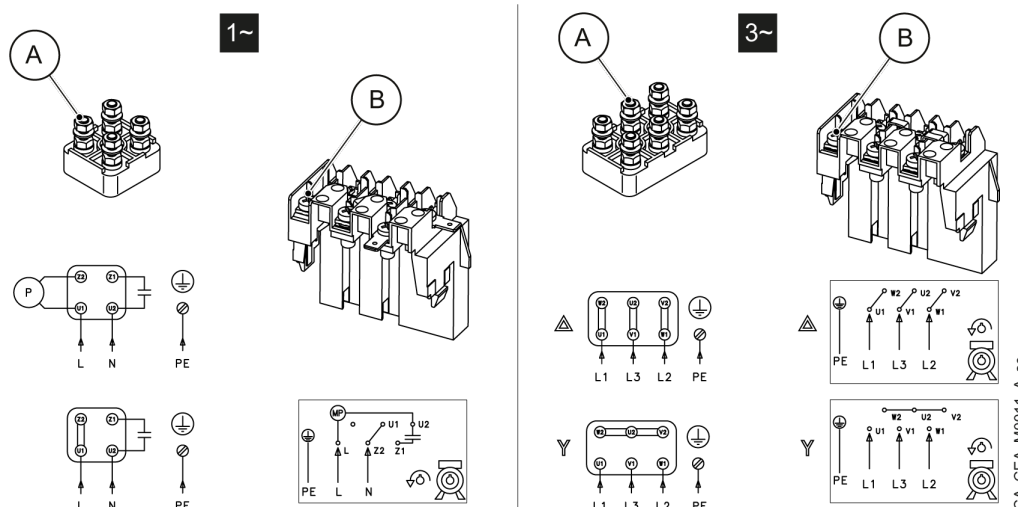

	A					B
Wrench, mm	M4	M5	M6	M8	M10	-
Tightening torque, Nm (lbf-in)	1,2 (11)	2,5 (22)	4,0 (35)	8,0 (71)	15,0 (133)	1,2 (11)

6. Check the direction of rotation, following the procedure in **Checking the direction of rotation**.

Motor without automatic reset thermal overload protection

1. If the motor is used with full load, then set the value to the nominal current value on the data plate of the unit.
2. If the motor is used with partial load, then set the value of the operating current measured with a current pincer.
3. For three-phase motors with star-delta starting system, set the thermal relay downstream of the switching circuit at 58% of the rated or operating current.

6.4 Operation with frequency converter

The motors can be connected to a frequency converter for speed control.

- The converter exposes the motor insulation to a higher load, which is influenced by the length of the connecting cable. In this case, it is advisable to install a dV/dt or sinusoidal filter.
- Filters extend the life of the motor.
- The inductance on the motor side (dV/dt filter) reduces the dV/dt value on the rising edge and phases, levelling out the current waveform.
- The sinusoidal filter takes both the waveform of the current and the waveform of the voltage to the output of the sinusoidal frequency converters.
- Comply with the frequency converter manufacturer's instructions.
- The bearings of the motors, from size 315 S/M and up, are exposed to the risk of harmful currents: use electrically insulated bearings.
- The conditions of installation must guarantee protection against voltage peaks between the terminals and/or dV/dt in the table:

Motor size	Voltage peak, V	dV/dt, V/μs
up to 90R (500 V)	< 650	< 2200
from 90R to 180R	< 1400	< 4600

7 Use and operation

7.1 Precautions

Before starting the unit, check that the instructions in chapter **Mechanical installation** have been followed correctly.



WARNING: Injuries hazard

Ensure that electrical protection is installed, where required: risk of personal injury.



WARNING:

Make sure that the drained liquid cannot cause damage or injuries.



WARNING:

In the case of liquids that are excessively hot or cold, pay attention to the risk of injury.



WARNING:

It is prohibited to operate the unit when dry, not primed and below the rated flow rate.



WARNING:

It is prohibited to operate the unit with the on-off valves closed.



WARNING:

Observe the limits given on the data plate for the operation of the unit.



WARNING: Electrical hazard

Check that the unit is properly connected to the mains power supply.



WARNING: Hot surface hazard

Beware of the high temperature produced by the unit and motor.



WARNING:

It is prohibited to place flammable materials near the unit.

NOTE:

Check that the shaft can turn smoothly.

NOTE:

It is prohibited to use the unit in the case of cavitation.

NOTE:

The unit must be filled and vented properly before it can be started.

NOTE:

The maximum pressure delivered by the unit on the discharge side, influenced by the available pressure on the suction side, must be lower than the maximum operating pressure.

7.2 Filling and priming

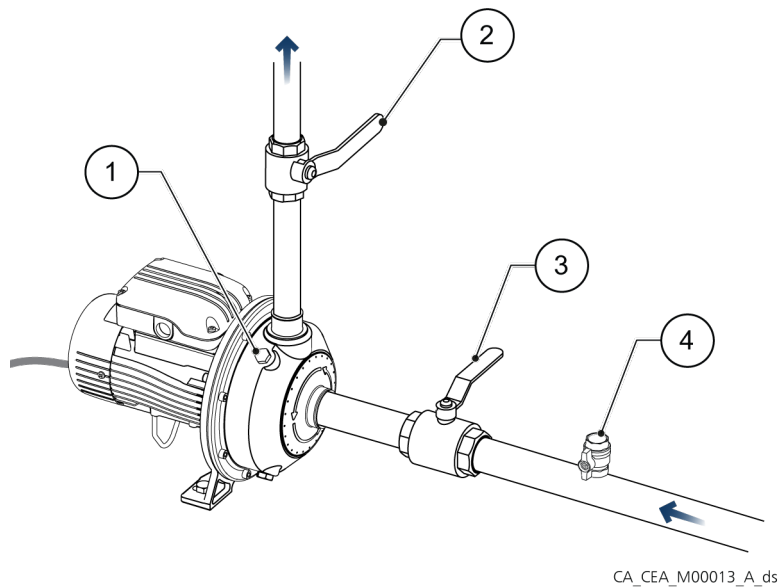

1. Filling plug
2. On-off valve on discharge line
3. On-off valve on suction line
4. Fill and relief valve

Positive suction head installation

1. Close both on-off valves.
2. Loosen the filler cap.
3. Slowly open the suction on-off valve until liquid flows evenly out of the filling hole; if necessary, loosen the cap further.
4. Tighten the cap.
Tightening torque: 8 Nm (70 lbf-in) \pm 25%.
5. Open both the on-off valves slowly and fully.

Suction lift installation

1. Open the on-off valve at the suction.
2. Shut the on-off valve located on the discharge line.
3. Remove the filler cap.
4. Partially open the filling valve.
5. Fill the unit from the filling hole and fill the suction piping from the filling valve.
6. Wait until the liquid flows out of the unit and add more liquid if necessary.
7. Close the filler cap.
Tightening torque: 8 Nm (70 lbf-in) \pm 25%.
8. Close the filling valve.
9. Slowly fully open the on-off valve on the discharge side.

7.3 Checking the direction of rotation (three-phase motor)

Before starting the unit:

NOTE:

Do not remove the protections during the entire direction check.

1. Stand on the side of the motor cooling fan.
2. Locate the arrows on the fan cover.
3. Start the unit and run it for a few seconds.
4. Check the rotation direction of the motor. The rotation of the motor must be as pointed by the arrows.
5. In case of incorrect rotation direction:
 - stop the unit
 - follow the procedure indicated in the next chapter
6. Repeat the check from step 3.

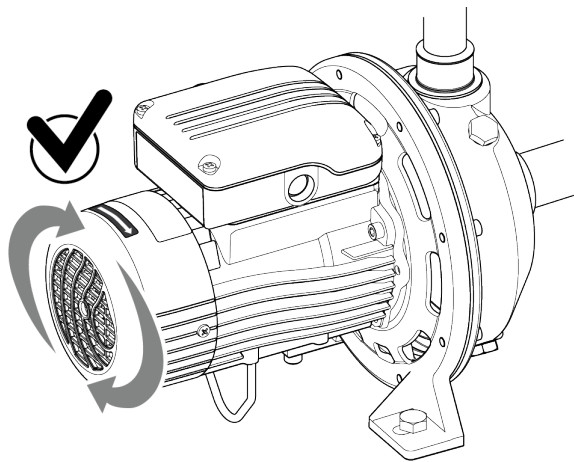

CA_CEA_M0014_A_05

If the direction of rotation is wrong and the unit is equipped with a single-phase motor, contact Xylem or the Authorised Distributor.

7.3.1 Wrong rotation direction (three-phase motor)

1. Disconnect the power supply.
2. Invert two of the three wires of the power cable in the terminal box of the motor or in the control electric panel.
3. Connect the power supply.
4. Start the unit.
5. Check the rotation direction through the motor cover.
6. Stop the unit.

7.4 Startup

NOTE:

It is prohibited to operate the unit with the on-off valves closed or at zero flow rate: risk of damage due to overheating of the liquid.

NOTE:

If there is a risk of the unit running at a flow rate below the minimum expected, install a bypass circuit.

Preliminary operations

Before starting the unit, check that all the operations listed in **Filling and priming** have been completed correctly.

Check the pre-charge of the expansion vessel

1. Check that the pressure of the system is zero, to avoid affecting the reading of the pressure gauge.
2. Unscrew the valve cap.

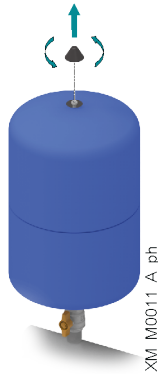

3. Attach the pressure gauge to the valve and charge the vessel to the desired pre-charge pressure. Pre-charge pressure = unit start pressure - 0.3 bar.

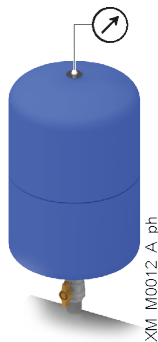

4. Remove the pressure gauge and screw the cap.

Startup

1. Close the on-off valve on the discharge side almost completely.
2. Fully open the suction on-off valve.
3. Start the unit.
4. Gradually open the on-off valve on the discharge side to half way.
5. Wait a few minutes and then open it completely.
6. Check the pressure gauge and ensure that the unit quickly reaches the correct pressure.

Final operations



WARNING:

After startup, run the unit for a few minutes with several users open in order to wash the inside of the system.

After the start-up procedure, with the pump unit in operation, check that:

- No liquid is leaking from the unit or pipes
- The maximum pressure of the unit at the discharge, determined by the available suction pressure, does not exceed the maximum operating pressure
- The current absorbed is within the rated limits (calibrate the thermal overload protection of the motor).

- There is no unwanted noise or vibrations
- No vortexes form at the end of the suction pipe (suction lift installation)
- The devices to prevent the absence of liquid (float or probes), or the minimum pressure devices work correctly
- With zero flow rate the unit stops automatically
- When the unit is stationary, it does not turn in the wrong direction due to a liquid backflow through the non-return valve
- The minimum flow rate in continuous operation is not less than the values indicated in the electrical specifications of the unit.

NOTE:

If the unit does not deliver the required pressure, repeat the operations in **Filling and priming**.

Settling of the mechanical seal

The pumped liquid lubricates the seal faces of the mechanical seal; under normal conditions, a small amount of liquid may leak out. When the unit is run for the first time, or immediately after the seal is replaced, more liquid may temporarily leak out.

To help the seal settle and to reduce leaking:

1. Close and open the on-off valve on the discharge side two or three times with the unit running.
2. Stop and start the unit two or three times.

7.5 Stopping the unit

1. Slowly close the discharge on-off valve.
2. Stop the unit and check that it actually stops.
3. Gradually re-open the on/off valve and check that the motor remains still.

8 Maintenance

8.1 Precautions

Before starting any work, make sure to read and understand all the safety instructions in **Introduction and Safety**.



DANGER: Electrical hazard

Before starting work, check that the electric power supply is disconnected and locked out, to avoid unintentional restart of the unit, the control panel and the auxiliary control circuit.



DANGER: Electrical hazard

If the unit is combined with a frequency converter, disconnect the power supply and wait 10 min to discharge the residual current.



WARNING:

Always use suitable working tools.



WARNING:

In the case of liquids that are excessively hot or cold, pay attention to the risk of injury.

8.2 Maintenance every 4000 hours of operation, or every year

Perform the following operations when the first of the two limits is reached:

Check that:

- No liquid is leaking from the unit or piping system
- There is no unwanted noise or vibrations
- The devices to prevent the absence of liquid (float or probes), or the minimum pressure devices work correctly
- The unit does not remain in operation with zero flow rate
- When the unit is stationary, it does not turn in the wrong direction due to a liquid backflow through the non-return valve.

Maintenance with the unit switched off and disconnected from the power supply

Check:

- The status of the power supply cable and control panel of the unit
- That there are no signs of overheating and electric arcs on the terminal boxes and traces of humidity inside the terminal box
- The pre-charge of the expansion vessel (see the instructions in **Startup**)
- The cleanliness of the fan cover and stator case
- The status of the cooling fan.

8.3 Maintenance every 10000 hours of operation or every 2 years

When the first of the two limits is reached, replace the mechanical seal and the o-rings. Contact Xylem or the Authorised Distributor for further technical information.

8.4 Maintenance every 17500 hours of operation or every 5 years

When the first of the two limits has been reached, replace the permanently lubricated bearings of the motor, if present.

8.5 Long periods of inactivity

1. Shut the suction and discharge on-off valves.
2. Follow the instructions in **Storage**.
3. Before starting the unit, check the status of the connections of the electric conductors on the unit and the control panel.
4. Start the unit following the instructions in **Startup**.

8.6 Identification of spare parts

Identify the spare parts with the product codes directly on the site spark.xylem.com.
Contact Xylem or the Authorised Distributor for further technical information.

9 Troubleshooting

Before starting any work, make sure to read and understand all the safety instructions in Introduction and Safety.



WARNING:

If a fault cannot be corrected or is not mentioned, contact Xylem or the Authorised Distributor.

9.1 The unit does not switch on

Cause	Solution
Electric power supply cut off	Reset the power supply
The residual current protection device (RCD) has tripped	Reset the protection device
The thermal overload protection of the motor has tripped	Reset the thermal protection
The device that detects the absence of liquid has tripped	Restore the liquid level
The minimum pressure device has tripped	Restore the minimum pressure
The starter of the unit does not work	Repair the device
Faulty unit starter	Replace the device
Damaged or defective power supply cable or joint	Repair or replace the cable
Faulty capacitor	Replace the capacitor
Control panel faulty	Check and repair or replace the control panel
Unit faulty	Contact Xylem or the Authorised Distributor, or send the unit to an authorised workshop

9.2 Little or no hydraulic performance

Cause	Solution
Unit not primed	<ul style="list-style-type: none"> Bleed the unit Increase the liquid level in the suction tank Remove any turbulences of the liquid in the suction area Check the suction conditions
On-off valve on discharge line closed	Open the valve
Non-return valve installed in the wrong direction	Reinstall the valve correctly
Check valve locked in the partially closed position	Repair or replace the valve
Suction filter clogged	Clean the filter
Clogged piping system	Remove the clogging
Liquid leaks from the piping system	Identify the leaks and repair the piping system
System with excessive friction losses	Replace the piping and/or fittings with some of a larger diameter or with a lower specific friction losses
Foreign bodies in the unit	Remove foreign bodies or contact Xylem or the Authorised Distributor, or send the unit to an authorised workshop
Three-phase motor turning in the wrong direction	Swap two of the three power supply phases
Unit in cavitation	Increase the available NPSH (net positive suction head)
Undersized unit	Contact Xylem or the Authorised Distributor, or send the unit to an authorised workshop.
Unit faulty	Contact Xylem or the Authorised Distributor, or send the unit to an authorised workshop

9.3 The unit starts and stops too frequently

Cause	Solution
Expansion vessel missing	Install an expansion vessel
Expansion vessel too small	<ul style="list-style-type: none"> Add another vessel to the system or Replace the vessel with a larger one
Expansion vessel empty	Pre-charge the vessel correctly
Expansion vessel faulty	Replace the vessel
Starter incorrectly calibrated	Adjust the device calibration
Starter faulty	Replace the device
Incorrectly installed level probes	Install the probes correctly
Faulty level probes	Replace the probes
Liquid leaks from the piping system	Identify the leaks and repair the piping system
Check valve faulty or defective	Replace the valve
Oversized unit	Contact Xylem or the Authorised Distributor, or send the unit to an authorised workshop

9.4 The unit produces excessive noise and/or vibrations

Cause	Solution
Plant resonance	Check the installation of the unit
Foreign bodies in the unit	Remove foreign bodies or contact Xylem or the Authorised Distributor, or send the unit to an authorised workshop
Water hammer	<ul style="list-style-type: none"> Close the discharge on-off valve before shutting down the unit, or Install an expansion vessel in the system, or Power the unit through a soft starter
Unit in cavitation	Increase the available NPSH (net positive suction head)
Unit not primed	<ul style="list-style-type: none"> Bleed the unit Increase the liquid level in the suction tank Remove any turbulences of the liquid in the suction area Check the suction conditions
Unit wrongly anchored to the foundations	Check the unit anchoring
Anti-vibration joints on the piping system not suitable and/or absent	Install or check the anti-vibration
Motor bearings worn or faulty	Replace the motor bearings or contact Xylem or the Authorised Distributor, or send the unit to an authorised workshop
The unit does not turn freely due to a mechanical fault	Contact Xylem or the Authorised Distributor, or send the unit to an authorised workshop
Unit faulty	Contact Xylem or the Authorised Distributor, or send the unit to an authorised workshop

9.5 The unit is leaking at the mechanical seal

Cause	Solution
Initial settling/running in of the mechanical seal	Carry out the procedure to help the mechanical seal settle (see chapter Startup)
Seal damaged or worn	Replace the seal or contact Xylem or the Authorised Distributor, or send the unit to an authorised workshop

9.6 The motor becomes excessively hot

Cause	Solution
Cooling fan of the motor clogged or damaged	Clean or replace the cooling fan
Incorrectly calibrated frequency converter (if present)	See the frequency converter manual
Room temperature too high, exposure to sunlight	<ul style="list-style-type: none"> • Check the ambient temperature • Protect the unit from sunlight
Unit faulty	Contact Xylem or the Authorised Distributor, or send the unit to an authorised workshop

9.7 Tripping of the thermal motor protection

The motor thermal overload protection triggers occasionally, or after the unit has been running for a few minutes.

Cause	Solution
Incorrectly calibrated thermal protection	Adjust the calibration of the thermal protection
Input voltage outside the rated limits	Ensure correct voltage values
Motor phase missing	Ensure correct voltage values
The unit operates with an excessive flow rate	Decrease the flow rate by partially closing the on-off valve on the discharge side
Liquid too thick	Decrease the density of the liquid
Solid or fibrous materials in the liquid	Remove the materials from the liquid
Thermal protection and/or fuses in the control panel exposed to high temperatures or sunlight	Protect the control panel; refer to the control panel manual
Loose electrical connections	Check that the electrical connections are tight
Damaged or defective power supply cable or joint	Repair or replace the cable
Unit faulty	Contact Xylem or the Authorised Distributor, or send the unit to an authorised workshop

9.8 The residual current protection device (RCD) has tripped

Cause	Solution
Unsuitable residual current protection device	Replace the device with a suitable one
Residual current protection device faulty	Replace the device
Unit faulty	Contact Xylem or the Authorised Distributor, or send the unit to an authorised workshop

10 Specifications

10.1 Operating environment

NOTE:

If the unit is exposed to:

- Temperature
- Humidity

above the permitted ones, contact Xylem or the Authorised Distributor.

NOTE: Danger of motor overheating

If the unit is installed at an altitude:

- Between 1500 and 2000 m (4900 to 6600 ft), reduce the power of the motor by 5%, or replace it with a more powerful one
- Above 2000 (6600), contact Xylem or the Authorised Distributor

The motor power reduction percentage refers to the permitted unit operating temperature.

Atmosphere

Non-aggressive and non-explosive.

Temperature

-15 to 45°C (5 to 113°F), with single-phase motor
 -15 to 40°C (5 to 104°F), with three-phase motor

Relative air humidity

< 50% at 40°C (104°F).

Elevation

< 1000 m (3280 ft) above sea level.

10.2 Operating temperature and pressure

The table shows the permissible liquid temperature and pressure limits, depending on the seal type.

Type of gasket	Min. - max. temperature, °C (°F)	Max. pressure, bar (psi)
NBR	-10 (14) ÷ 85 (185)	8 (116 psi)
FPM	-10 (14) ÷ 110 (230) -10 (14) to 80 (176) with water	
EPDM	-10 (14) ÷ 110 (230)	

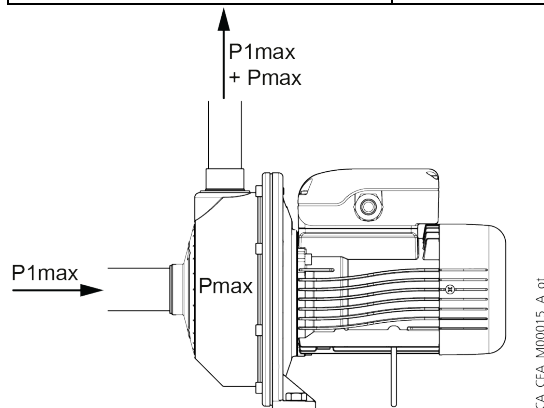

Data	Description
P1max	Maximum input pressure
Pmax	Maximum pressure generated by the unit
PN	Maximum operating pressure

$$P1max + Pmax \leq PN$$

10.3 Maximum head

10.3.1 GCEA and GCIE series

50 Hz motors

Model	Max. head, m (ft)	
	Single-phase	Three-phase
70/3	22 (72)	22 (72)
70/5	32 (105)	31 (102)
80/5	33 (108)	32 (105)
120/3	22 (72)	22 (72)
120/5	32 (105)	32 (105)
210/2	18 (59)	18 (59)
210/3	21 (69)	21 (69)
210/4	26 (85)	26 (85)
210/5	-	29 (95)
370/1	16 (52)	16 (52)
370/2	20 (66)	20 (66)
370/3	-	24 (79)
370/5	-	30 (98)

60 Hz motors

Model	Max. head, m (ft)	
	Single-phase	Three-phase
706/3	33 (108)	32 (105)
706/4	-	39 (128)
706/5	-	45 (148)
1206/1	22 (73)	22 (73)
1206/2	28 (91)	28 (91)
1206/3	-	33 (108)
1206/4	-	40 (131)
1206/5	-	47 (154)
2106/0	17 (56)	17 (56)
2106/1	-	21 (69)
2106/2	-	25 (82)
2106/3	-	30 (98)
2106/4	-	35 (115)
3706/0	-	17 (56)
3706/0A	-	20 (66)
3706/1	-	24 (79)
3706/2	-	30 (98)
3706/3	-	35 (115)

10.3.2 GCA series

50 Hz motors

Model	Max. head, m (ft)	
	Single-phase	Three-phase
70/33	44 (144)	43 (141)
70/34	49 (161)	48 (157)
70/44	52 (171)	-
70/45	-	58 (190)
120/33	45 (148)	44 (144)
120/34	49 (161)	-
120/35	-	55 (180)
120/55	-	63 (207)
200/33	-	43 (141)
200/35	-	53 (174)
200/55	-	63 (207)

60 Hz motors

Model	Max. head, m (ft)	
	Single-phase	Three-phase
706/33	-	63 (207)
1206/33	-	64 (210)
2006/33	-	64 (210)

10.4 Maximum number of starts and stops

Unit rated power, kW	0,25÷3	4÷7,50	11÷15	18,5÷22	30÷37	45÷75	90÷160
No. of start-ups at regular intervals per h	60	40	30	24	16	8	4

10.5 Electrical specifications

See the motor data plate.

Permitted tolerances for the supply voltage

Frequency Hz	50		60	
	1~	3~	1~	3~
UN [V] ± %	220÷240 ± 6	230/400 ± 10 400/690 ± 10	220÷230 ± 6	220/380 ± 5 380/660 ± 10
No. of conductors + ground	2+1	3+1	2+1	3+1

Protection class

Motor: IP55

Electric pump: IPX5

For possible condensation inside the motor, see **Environments prone to condensation**.

10.6 Sound pressure

< 70 dB (A), measured in free field, at a distance of one metre from the unit, during no-load operation at 3600 rpm.

10.7 Materials in contact with the liquid

Model	Material
GCEA, GCIE, GCA	Stainless steel/AISI 304
GCEA..N, GCA..N	AISI 316L stainless steel

11 Disposal

11.1 Precautions



WARNING:

The unit must be disposed of through approved companies specialised in the identification of different types of materials: steel, copper, plastic, lithium, ferrite etc...



WARNING:

It is prohibited to dispose of lubricating fluids and other hazardous substances in the environment.

11.2 WEEE (EU/EEA)

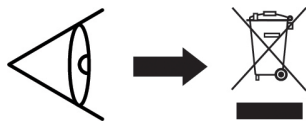

INFORMATION TO USERS pursuant to art. 14 of the Directive 2012/19/EU of the European Parliament and of the Council of 4 July 2012 on waste electrical and electronic equipment (WEEE). The crossed bin symbol on the appliance or on its packaging indicates that the product at the end of its useful life must be collected separately and not disposed of together with other mixed urban waste. Appropriate separate collection for the subsequent start-up of the disused equipment for recycling, treatment and environmentally compatible disposal helps to avoid possible negative effects on the environment and on health and favours the re-use and / or recycling of the materials of which the equipment is composed.

WEEE from private households (Classification according to product type, use and current local laws): please contact your municipality, or local authority, for all information regarding the separate collection systems available in the area. The retailer is obliged to collect the old equipment free of charge when buying new equipment of an equivalent type, for the purpose of starting the correct recycling / disposal.

WEEE from users other than private households (Classification according to product type, use and current local laws): the separate collection of this equipment at the end of its life is organized and managed by the produce (Producer of EEE as per Directive 2012/19/EU). The user who wants to get rid of this equipment can then contact the producer and follow the system that it has adopted to allow the separate collection of equipment at the end of life or select an organization independently authorized to manage waste.

11.3 WEEE (UK)

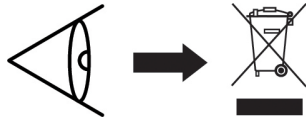

INFORMATION TO USERS pursuant to art. 44 of the The Waste Electrical and Electronic Equipment Regulations 2013 (S. I. 2013 No. 3113). The crossed bin symbol on the appliance or on its packaging indicates that the product at the end of its useful life must be collected separately and not disposed of together with other mixed urban waste. Appropriate separate collection for the subsequent start-up of the disused equipment for recycling, treatment and environmentally compatible disposal helps to avoid possible negative effects on the environment and on health and favours the re-use and / or recycling of the materials of which the equipment is composed.

WEEE from private households (Classification according to product type, use and current local laws): please contact your municipality, or local authority, for all information regarding the separate collection systems available in the area. The retailer is obliged to collect the old equipment free of charge when buying new equipment of an equivalent type, for the purpose of starting the correct recycling / disposal.

WEEE from users other than private households (Classification according to product type, use and current local laws): the separate collection of this equipment at the end of its life is organized and managed by the producer (Producer of EEE as per WEEE Regulations 2013). The user who wants to get rid of this equipment can then contact the producer and follow the system that it has adopted to allow the separate collection of equipment at the end of life or select an organization independently authorized to manage waste.

12 Declarations

Refer to the specific declaration relating to the marking on the product.



12.1 Electric pump

EC Declaration of Conformity (Original)

Xylem Service Italia S.r.l., with headquarters in Via Vittorio Lombardi 14 - 36075 Montecchio Maggiore VI - Italy, hereby declares that the product:

GCEA...or GCIE...or GGCA ... electric pump (see label on the last page of "Safety and Other Information" manual)

fulfils the relevant provisions of the following European Directives

- Machinery 2006/42/EC and subsequent amendments (ANNEX II - natural or legal person authorised to compile the technical file: Xylem Service Italia S.r.l.).
- Eco-design 2009/125/EC and subsequent amendments, Regulation (EU) 2019/1781 and subsequent amendments (electric motor, if IE2, IE3 or IE4 marked), Regulation (EU) No 547/2012 and subsequent amendments (water pump, if MEI marked)

and technical standards

- $U_N 1 \sim \leq 250 \text{ V}$, $3 \sim \leq 480 \text{ V}$: EN 60335-1:2012+A11:2014 +A13:2017+A14:2019+A1:2019+A2:2019+A15:2021+A16:2023, EN IEC 60335-2-41:2021+ A11:2021, EN 62233:2008.
 $U_N 1 \sim > 250 \text{ V}$, $3 \sim > 480 \text{ V}$: EN 60204-1:2018.
- EN 60034-30:2009, EN 60034-2-1:2007, EN 60034-30-1:2014, EN 60034-2-1:2014
EN 16480:2021.

Montecchio Maggiore, 10/02/2025

Alessio Vendraminelli
Managing Director

rev.00

EU Declaration of Conformity (No 79)

1. EMCD - Apparatus/Product model: GCEA...or GCIE...or GCA ... electric pump (see label on the last page of "Safety and Other Information" manual)
RoHS - Unique identification of the EEE: GCEA, GCIE, GCA.
2. Name and address of the manufacturer:
Xylem Service Italia S.r.l.
Via Vittorio Lombardi 14
36075 Montecchio Maggiore VI
Italy
3. This declaration of conformity is issued under the sole responsibility of the manufacturer.
4. Object of the declaration: electric pump
5. The object of the declaration described above is in conformity with the relevant Union harmonization legislation:
 - Directive 2014/30/EU of 26 February 2014 and subsequent amendments (electromagnetic compatibility).

- Directive 2011/65/EU of 8 June 2011 and subsequent amendments, including directive (EU) 2015/863 (restriction of the use of certain hazardous substances in electrical and electronic equipment).
6. References to the relevant harmonised standards used or references to the other technical specifications, in relation to which conformity is declared:
- EN 61000-3-3:2013+A1:2019+A2:2021. U_N 1 ~ \leq 250 V, 3 ~ \leq 480 V: EN 55014-1:2017+A11: 2020, EN IEC 55014-1:2021, EN 55014-2:1997+ A1: 2001+A2:2008, EN IEC 55014-2:2021. U_N 1 ~ $>$ 250 V, 3 ~ $>$ 480 V: EN 61000-6-1:2007, EN IEC 61000-6-1:2019, EN 61000-6-2:2005, EN IEC 61000-6-2:2019, EN 61000-6-3:2007+ A1:2011, EN IEC 61000-6-3:2021, EN 61000-6-4:2007 +A1:2011, EN IEC 61000-6-4:2019.
 - EN IEC 63000:2018.
7. Notified body: -
8. Additional information:
RoHS - Annex III - Applications exempt from the restrictions: lead as a binding element in steel, aluminium and copper alloys [6(a), 6(b), 6(c)].

Signed for and on behalf of: Xylem Service Italia S.r.l.

Montecchio Maggiore, 10/02/2025

Alessio Vendraminelli
Managing Director



rev.00

Goulds is a registered trademark of Goulds Pumps, Inc., and is used under license.

12.2 Pump unit (electric pump) (UKCA)



UK Declaration of Conformity (original)

Xylem Service Italia S.r.l., with headquarters in Via Vittorio Lombardi 14 - 36075 Montecchio Maggiore VI - Italy, hereby declares that the product:

GCEA...or GCIE...or GCA ... electric pump (see label on the last page of "Safety and Other Information" manual)

fulfils the relevant provisions of the following UK legal acts

- S.I. 2008/1597 - Supply of Machinery (Safety) Regulations 2008 and subsequent amendments (Schedule 2 - Part 2 - Annex II - natural or legal person authorised to compile the technical file: Xylem Service Italia S.r.l.).
- S.I. 2021/745 - The Ecodesign for Energy-Related Products and Energy Information Regulations 2021 and subsequent amendments (electric motor, if IE2, IE3 or IE4 marked) S.I. 2019/539 - The Ecodesign for Energy-Related Products and Energy Information (Amendment) (EU Exit) Regulations 2019 and subsequent amendments (water pump, if MEI marked)

and technical standards

- $U_N 1 \sim \leq 250 \text{ V}$, $3 \sim \leq 480 \text{ V}$: EN 60335-1:2012+A11:2014 +A13:2017+A14:2019+A1:2019+A2:2019+A15:2021+A16:2023, EN IEC 60335-2-41:2021+ A11:2021, EN 62233:2008.
 $U_N 1 \sim > 250 \text{ V}$, $3 \sim > 480 \text{ V}$: EN 60204-1:2018.
- EN 60034-30:2009, EN 60034-2-1:2007, EN 60034-30-1:2014, EN 60034-2-1:2014, EN 16480:2021.

Montecchio Maggiore, 10/02/2025

Alessio Vendraminelli
Managing Director

rev.00

UK Declaration of Conformity (No. 79)

1. EMCD - Apparatus/Product model: GCEA...or GCIE...or GCA ... (see label on the last page of "Safety and Other Information" manual)
RoHS - Unique identification of the EEE: GCEA, GCIE, GCA.
2. Name and address of the manufacturer:
Xylem Service Italia S.r.l.
Via Vittorio Lombardi 14
36075 Montecchio Maggiore VI
Italy
3. This declaration of conformity is issued under the sole responsibility of the manufacturer.
4. Object of the declaration: electric pump
5. The object of the declaration described above is in conformity with the relevant UK legislative acts:
 - S.I. 2016/1091 - The Electromagnetic Compatibility Regulations 2016 and subsequent amendments.
 - S.I. 2012/3032 - The Restriction of the Use of Certain Hazardous Substances in Electrical and Electronic Equipment Regulations 2012 and subsequent amendments.
6. References to the relevant designated standards used or references to the other technical specifications, in relation to which conformity is declared:
 - EN 61000-3-3:2013+A1:2019+A2:2021,

$U_N 1 \sim \leq 250 \text{ V}, 3 \sim \leq 480 \text{ V}$: EN 55014-1:2017+ A11:2020, EN IEC 55014-1:2021, EN 55014-2:1997+ A1:2001+A2:2008, EN IEC 55014-2:2021.

$U_N 1 \sim > 250 \text{ V}, 3 \sim > 480 \text{ V}$: EN 61000-6-1:2007, EN IEC 61000-6-1:2019, EN 61000-6-2:2005, EN IEC 61000-6-2:2019, EN 61000-6-3:2007+A1:2011, EN IEC 61000-6-3:2021, EN 61000-6-4:2007 +A1:2011, EN IEC 61000-6-4:2019.

- EN IEC 63000:2018.

7. Approved body: -

8. Additional information:

RoHS - S.I. 2020/1647 - The Hazardous Substances and Packaging (Legislative Functions and Amendment) (EU Exit) Regulations 2020 - regulation 3 (1), Schedule A2, Table 1 - Exempted applications from the restrictions: lead as a binding element in steel, aluminium and copper alloys [12, 15, 18].

Signed for and on behalf of: Xylem Service Italia S.r.l.

Montecchio Maggiore, 10/02/2025

Alessio Vendraminelli
Managing Director



rev.00

Goulds is a registered trademark of Goulds Pumps, Inc., and is used under license.

13 Warranty

For information on the warranty refer to the commercial documentation.

Xylem |'zīləm|

- 1) The tissue in plants that brings water upward from the roots;
- 2) A leading global water technology company.

We're a global team unified in a common purpose: creating innovative solutions to meet our world's water needs. Developing new technologies that will improve the way water is used, conserved, and re-used in the future is central to our work. We move, treat, analyze, and return water to the environment, and we help people use water efficiently, in their homes, buildings, factories and farms. In more than 150 countries, we have strong, long-standing relationships with customers who know us for our powerful combination of leading product brands and applications expertise, backed by a legacy of innovation.

For more information on how Xylem can help you, go to www.xylem.com



Xylem Service Italia S.r.l.
Via Vittorio Lombardi 14
36075 - Montecchio Maggiore (VI) - Italy
xylem.com/lowara

Lowara is a trademark of Xylem Inc. or one of its subsidiaries. ©
2025 Xylem, Inc. Cod. 001080214GEN rev.A ed.02/2025