

BASES SUPPLIED WITHOUT LIFTING HOLES (Cont'd):

On double suction pumps, hitch around the outboard bearing housing. Place remaining sling around the back end of the motor as close to the mounting feet as possible. Make certain sling will not damage housing cover or conduit boxes.

Join free ends of the slings together and place over the lifting hook.

CAUTION: Use extreme care when positioning sling under motor so cannot slip off motor.

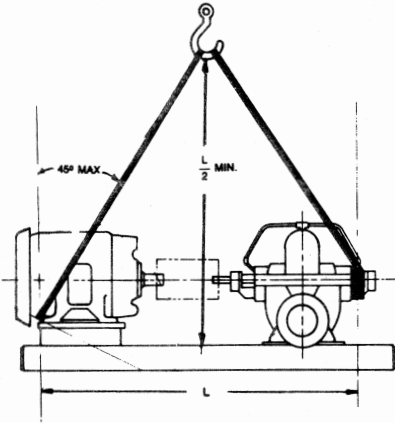

Fig. 6

G&L Pumps Series A-C 8100/8300/9100

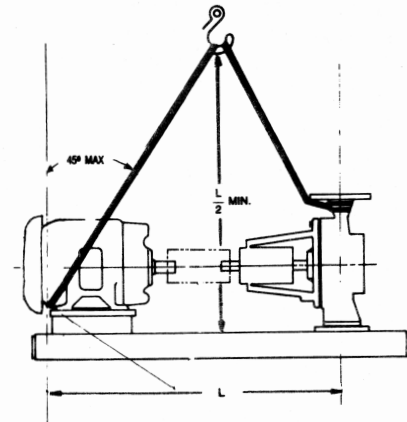

Fig. 7

CONFIGURATION 600: HORIZONTAL CLOSE COUPLE. See Fig. 8.

Equipment: Nylon Sling, Wire Rope, or Chain.

Hitch Method: Choker Hitch

Place one hitch around the back end of the motor using a choker hitch. Place hitch as close to motor feet as possible.

Place remaining hitch around the pump discharge using a choker hitch.

Size equipment so that the lift angle is less than 45° from vertical.

Lift equipment vertically.

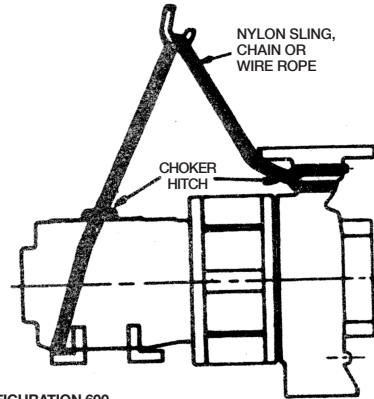

CONFIGURATION 600

Fig. 8

Goulds Water Technology Series A-C 2000



AC0920
REV. G

**G&L Pumps Series A-C
8100/8300/9100
Goulds Water Technology
Series A-C 2000**

**HORIZONTAL PUMP
LIFTING INSTRUCTIONS**

**READ BEFORE LIFTING
THIS PRODUCT**

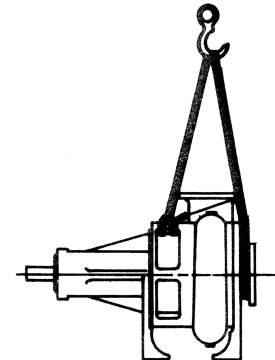

xylem
Let's Solve Water

Xylem Inc.
8200 N. Austin Avenue
Morton Grove, Illinois 60053
Phone: (847) 966-3700
Fax: (847) 965-8379
www.xylem.com/brands/bellgossett

G&L Pumps is a trademark of Xylem Inc. or one of its subsidiaries.
Goulds is a trademark of Goulds Pumps, Inc. and is used under license.
© 2013 Xylem Inc. AC-0920 Rev. G August 2013

xylem
Let's Solve Water

LIFTING INSTRUCTIONS FOR HORIZONTAL PUMPS

The following are instructions for the safe lifting of your pump. The methods are grouped by configuration so it will be necessary to check the name plate to establish the configuration of your pump. Find the corresponding configuration in the booklet and read the lifting instructions carefully.

NOTE: If for some reason the configuration number on the name plate does not agree with the way the pump is built, use the lifting method that best describes your pump. At all times follow safe lifting practices.

Protect all lifting equipment from sharp edges when lifting.

Use only OSHA or ANSI approved equipment.

If necessary, use spreader bars to avoid damaging equipment mounted on base.

CAUTION: When using “S” hooks do not point load the hook.

Please note the following IMPORTANT information when shoulder eyebolts are to be used to lift the pump.

— At temperatures below 50°F (10°C), published working loads for standard eyebolts become questionable. Carbon steel, normally used for standard eyebolts, is subject to a decrease in shock resistance and ductility at the low temperatures. To permit use of forged carbon steel eyebolts to 0°F (-17.8°C) specifications for carbon steel eyebolts shall require that the material meet a Charpy impact test of 15 ft. lbs. at 0°F (-17.8°C).

a) To minus 25°F (-32°C): use heat treated low carbon alloy steel. The material shall meet the requirements of SAE 4320.

b) Under minus 25°F (-32°C): use austenitic type steels. Compare material properties between the specified austenitic steel and the carbon steel of ASTM A489 (65,000 psi min. tensile, 30,000 psi [207MPa] mm yield). Use a ratio of austenitic steel vs the carbon steel of ASTM A489 (65,000 psi min. tensile, 30,000 psi min. yield times the standard capacity values of the eyebolt.

— Eyebolts can be used at temperatures up to 500°F (260°C) without affecting the capacity ratings.

CONFIGURATION 100: (BARE PUMPS) See Figs 1, 2, or 3.

Equipment: Nylon Sling, Wire Rope, Chain.

Hitch Method: Choker Hitch (Basket hitch for double suction pumps).

Place one sling around the upper rib on pump frame, and one sling behind the suction flange on pumps with off centerline discharge or below the discharge flange for pumps with centerline discharge. For pumps with off centerline discharge, it may be necessary to run a stabilizing line to the discharge flange.

On double suction pumps hitch around both bearing supports.

CONFIGURATION 700: (SUCTION DIFFUSERS) See Fig. 4.

Equipment: Nylon Sling.

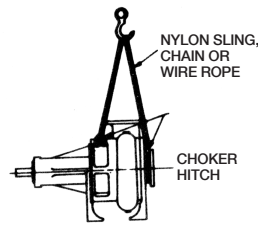

Fig. 1
CONFIGURATION 100
OFF CENTER DISCHARGE

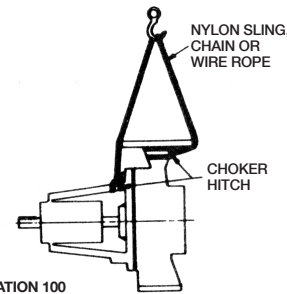

Fig. 2
CONFIGURATION 100
CENTER LINE DISCHARGE

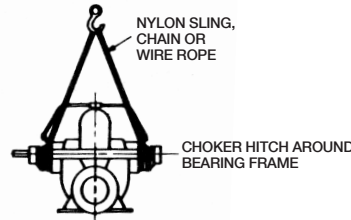

Fig. 3
CONFIGURATION 100
DOUBLE SUCTION

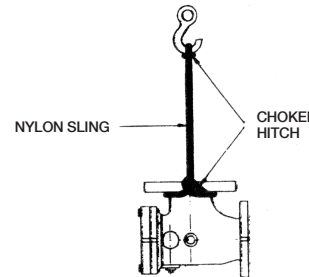

Fig. 4
CONFIGURATION 700

G&L Pumps Series A-C 8100/8300/9100

Hitch Method: Choker Hitch.

Place one hitch around the system side of the suction diffuser using a choker hitch.

Place hitch all the way around neck, up against the flange.

Place the remaining hitch around the hook using a choker hitch as shown.

Lift equipment vertically.

CONFIGURATION 150: (PUMP BASE AND DRIVER) See Fig. 5.

NOTE: Care must be taken to size equipment for unbalanced loads which may exist if the motor is not mounted on the base at the time of lifting. Motor may or may not be mounted at the factory.

CAUTION: Pump, base, and driver assemblies where the base length exceeds 100 inches may not be safe to lift as a complete assembly. Damage to the baseplate may occur. If the driver has been mounted on the baseplate at the factory, it is safe to lift entire assembly. If the driver has not been mounted at the factory and overall baseplate length exceeds 100 inches, do not lift entire assembly consisting of pump, base, and driver. Instead, lift the pump and baseplate to its final location without the driver. Then mount the driver.

BASES SUPPLIED WITH LIFTING HOLES:

Large bases are supplied with lifting holes in the sides or the ends of the base. See Fig. 5A and 5B.

Equipment: Chain, Wire Rope or Nylon Slings, all with formed end loops, or Master Links. ANSI/OSHA Standard “S” hooks.

Hitch Method: Four Leg Basket Hitch.

Place “S” hooks in holes provided in the four corners of the base. Be sure points of hooks do not touch bottom of pump base. Attach nylon slings, wire rope, or chains to “S” hooks.

Size equipment for the load, and so the lift angle will be less than 45° from vertical.

Lift equipment vertically.

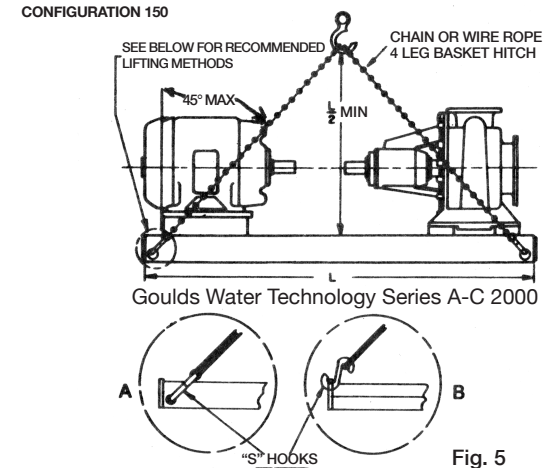

Fig. 5

BASES WITH LIFTING EYEBOLTS:

Equipment: Standard Anchor Shackles, Chain or Wire Rope, with Latch Hooks, Master Links or formed End Loops.

Hitch Method: Four Leg Basket Hitch.

Attach shackles and chain or wire rope to the four lifting eyes. Be sure the chain or wire rope is of sufficient length to keep the lift angle less than 45° from vertical. Also be sure the lift angle in the direction at right angles to the lifting lug is less than 20° from vertical. If necessary shims may be used with the lifting eyes to insure they are oriented properly with the lifting plane.

BASES SUPPLIED WITHOUT LIFTING HOLES: See Figs. 6, 7.

Equipment: Nylon Slings, Wire Rope, or Chains.

Hitch Method: Choker Hitch/Sling.

Place one sling below the discharge flange and secure with a choker hitch.