



AQUAVAR[®] CPC

SUPPLEMENT A - Variable Speed Drive

SUPPLEMENT TO THE INSTALLATION AND OPERATION MANUAL (IM167)

TABLE OF CONTENTS

SAFETY

Use of Warnings and Notes.....	3
--------------------------------	---

INSTALLATION

Application	4
Input Disconnect Features and Functions	4
Installation Flow Chart.....	6
Preparing for Installation (Supplement to Aquavar CPC-01/U1 User’s Manual).....	7
Installing the Drive (Supplement to Aquavar CPC-01/U1 User’s Manual).....	9
Installing the Wiring (Supplement to Aquavar CPC-01/U1 User’s Manual)	10

MAINTENANCE

Maintenance Intervals	14
Drive Module Fan Replacement	14
Enclosure Fan Replacement - NEMA 12 Enclosures	15
Enclosure Air Filter Replacement - NEMA 12 Enclosures.....	16

TECHNICAL DATA

Cable Sizing / Ratings.....	19
Fuse Sizing / Ratings.....	22
Ratings (Supplement to Aquavar CPC-01/U1 User’s Manual).....	25
Input Power Connections (Supplement to Aquavar CPC-01/U1 User’s Manual)	26
Motor Connections.....	32
Cooling - R7/R8.....	32
Dimensions and Weights (Supplement to Aquavar CPC-01/U1 User’s Manual).....	33
Applicable Standards and Markings	40

INDEX	42
--------------------	----

SAFETY



WARNING! The AQUAVAR CPC adjustable speed AC drive with Input Disconnect should ONLY be installed by a qualified electrician.



WARNING! Even when the motor is stopped, dangerous voltage is present at the Power Circuit terminals U1, V1, W1 and U2, V2, W2 and, depending on the frame size, UDC+ and UDC-, or BRK+ and BRK-.



WARNING! Dangerous voltage is present when input power is connected. After disconnecting the supply, wait at least 5 minutes (to let the intermediate circuit capacitors discharge) before removing the cover.



WARNING! Even when power is removed from the input terminals of the AQUAVAR CPC, there may be dangerous voltage (from external sources) on the terminals of the relay outputs.



WARNING! When the control terminals of two or more drive units are connected in parallel, the auxiliary voltage for these control connections must be taken from a single source which can either be one of the units or an external supply.



WARNING! The AQUAVAR CPC will start up automatically after an input voltage interruption if the external run command is on.



WARNING! When the AQUAVAR CPC with Input Disconnect is connected to the line power, the Motor Terminals T1, T2 and T3 are live even if the motor is not running. Do not make any connections when the AQUAVAR CPC with Input Disconnect is connected to the line. Disconnect and lock out power to the drive before servicing the drive. Failure to disconnect power may cause serious injury or death.

NOTE! For more technical information, contact the factory or your local AQUAVAR representative.

WARNING! Do not attempt to install or remove EM1, EM3, F1 or F2 screws while power is applied to the drive's input terminals.

WARNING! Do not control the motor with disconnecting device (disconnecting means); instead, use the control panel start and stop keys, or commands via the I/O board of the drive. The maximum allowed number of charging cycles of the DC capacitors (i.e. power-ups by applying power) is five in ten minutes.

WARNING! The opening of a branch-circuit protective device may be an indication that a fault has been interrupted. To reduce the risk of fire or electric shock, current-carrying parts and other components of the controller should be examined and replaced if damaged or equivalent.

USE OF WARNINGS AND NOTES

There are two types of safety instructions throughout this manual:

- Notes draw attention to a particular condition or fact, or give information on a subject.
- Warnings caution you about conditions which can result in serious injury or death and/or damage to the equipment. They also tell you how to avoid the danger. The warning symbols are used as follows:



DANGEROUS VOLTAGE WARNING warns of high voltage which can cause physical injury and/or damage to the equipment.



GENERAL WARNING warns about conditions, other than those caused by electricity, which can result in physical injury and/or damage to the equipment.

INSTALLATION

Study these installation instructions carefully before proceeding. Failure to observe the warnings and instructions may cause a malfunction or personal hazard.



WARNING! Before you begin read "Safety" on page 3.



WARNING! When the Aquavar CPC with Input Disconnect is connected to the line power, the Motor Terminals T1, T2, and T3 are live even if the motor is not running. Do not make any connections when the Aquavar CPC with Input Disconnect is connected to the line. Disconnect and lock out power to the drive before servicing the drive. Failure to disconnect power may cause serious injury or death.

Application

This manual contains supplemental information that is unique to Aquavar CPC input disconnect configurations ("FD" suffix). Refer to the base manual, Aquavar CPC User's Manual (IM167), for all other information.

Input Disconnect Features and Functions

The Aquavar CPC with Input Disconnect is an Aquavar CPC AC adjustable frequency drive packaged with an input disconnect switch, and with a door mounted, external operating handle. The operating handle can be padlocked in the OFF position (padlock not supplied). Enclosure options are NEMA 1, NEMA 12 and NEMA 3R (UL Type 1, UL Type 12 and UL Type 3R).

The following is a typical power diagram:

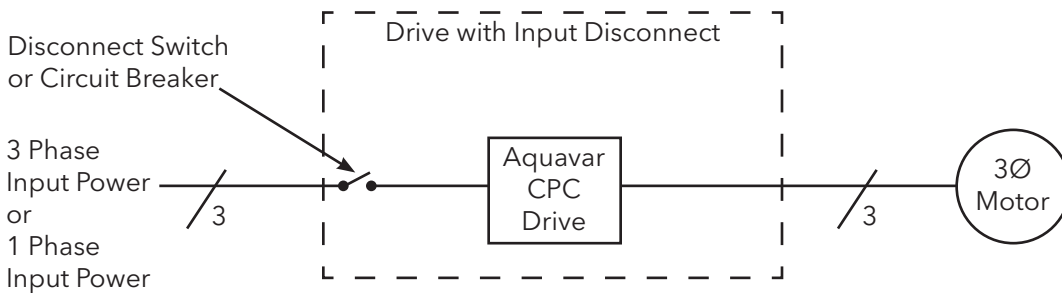

INSTALLATION

The following figures show the front view of the Aquavar CPC Input Disconnect standard configurations and identify the major components.

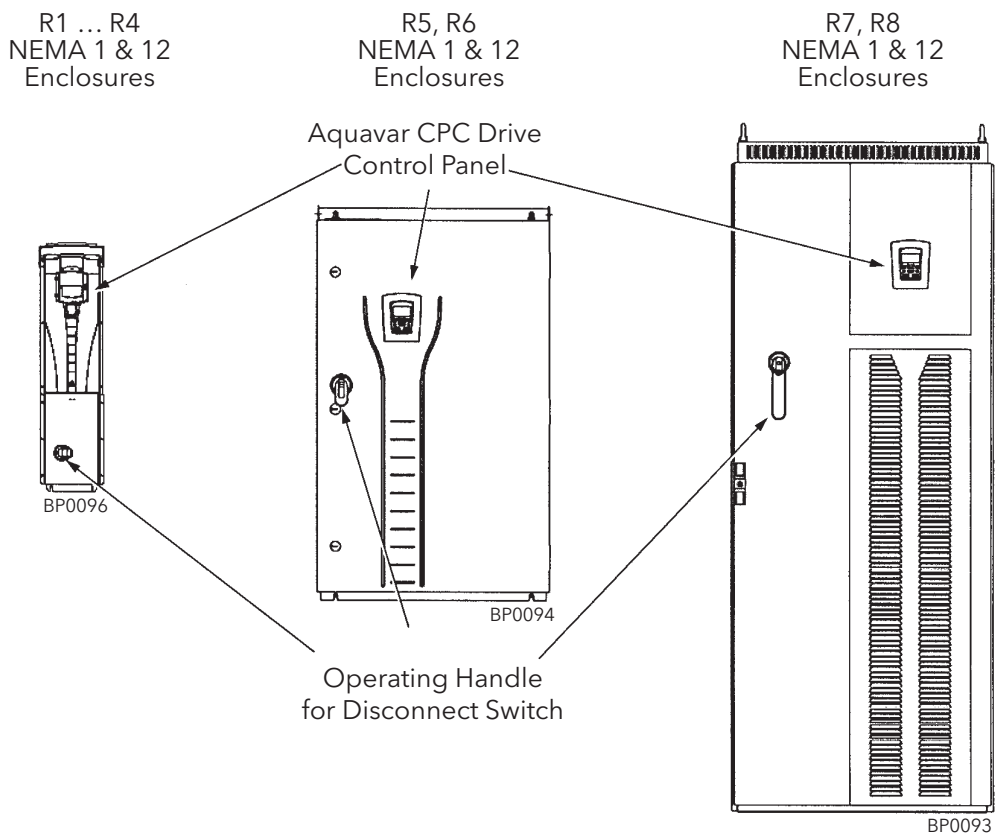

INSTALLATION

Installation Flow Chart

The installation of Input Disconnect configurations for Aquavar CPC drives follows the outline below. The steps must be carried out in the order shown. At the right of each step are references to the detailed information needed for the correct installation of the unit.

NOTE! References in the middle column below are to the Aquavar CPC User’s Manual (IM167). References in the third column below are to this manual.

Task	Refer to the Aquavar CPC User’s Manual “Installation” Section	Additional Reference in this Manual
<div style="border: 1px solid black; padding: 5px; width: fit-content;"> PREPARE for installation </div>	“Preparing for Installation”	<ul style="list-style-type: none"> • R7/R8: “Lifting the Drive” on page 7. • “Drive Identification” on page 8. • “Suitable Mounting Location” on page 9.
<div style="border: 1px solid black; padding: 5px; width: fit-content;"> PREPARE the Mounting Location </div>	“Prepare the Mounting Location”	<ul style="list-style-type: none"> • R7/R8: “Prepare the Mounting Location – R7 and R8” on page 9. • “Dimensions and Weights (Supplement to Aquavar CPC User’s Manual)” on page 27.
<div style="border: 1px solid black; padding: 5px; width: fit-content;"> REMOVE the front cover </div>	“Remove Front Cover”	R7/R8: “Remove Side Panel- R7 and R8 NEMA 1 and 12 Enclosures” on page 9.
<div style="border: 1px solid black; padding: 5px; width: fit-content;"> MOUNT the drive </div>	“Mount the Drive”	R7/R8: “Mount the Drive” on page 10.
<div style="border: 1px solid black; padding: 5px; width: fit-content;"> INSTALL wiring </div>	“Wiring Overview” and “Install the Wiring”	“Installing the Wiring (Supplement to Aquavar CPC User’s Manual)” starting on page 10.
<div style="border: 1px solid black; padding: 5px; width: fit-content;"> CHECK installation </div>	“Check Installation”	–
<div style="border: 1px solid black; padding: 5px; width: fit-content;"> REINSTALL the cover </div>	“Reinstall Cover”	–
<div style="border: 1px solid black; padding: 5px; width: fit-content;"> APPLY power </div>	“Apply Power”	–
<div style="border: 1px solid black; padding: 5px; width: fit-content;"> START-UP </div>	“Start-Up”	–

INSTALLATION

Preparing for Installation (Supplement to Aquavar CPC User's Manual)

Lifting the Drive

R7...R8 Frames



WARNING! Handle and ship floor mounted enclosures only in the upright position. These units are not designed to be laid on their backs.

1. Use a pallet truck to move the package/enclosure to the installation site.

2. Remove the cabinet side panels from NEMA 1 and 12 enclosures for access to the cabinet/pallet mounting bolts. (Six (6) torx screws hold each cabinet side panel in place. Leave the side panels off until later.)

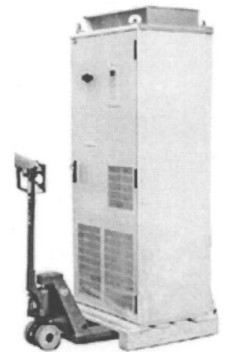

PC00005

3. Remove the 4 bolts that secure the cabinet to the shipping pallet.



WARNING! Use the lifting lugs/bars at the top of the unit to lift R7/R8 drives.

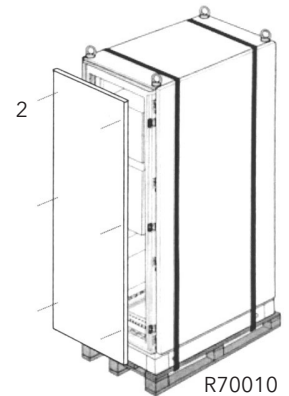

R70010

4. Use a hoist to lift the drive. (Do not place drive in final position until mounting site is prepared.)

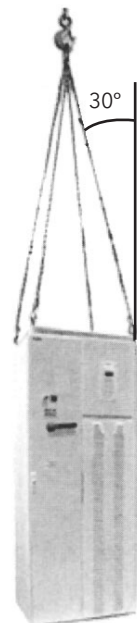

PC00003

INSTALLATION

Preparing for Installation (Supplement to Aquavar CPC User's Manual)

Drive Identification

To identify the type of device you are installing, refer to the type code number on the device identification label.

- Wall mounting base drives - label attached on the side surface of the heat sink.
- Packaged drive with screw cover - label attached to outside surface on the left side of the enclosure.
- Enclosure with hinged cover/door - label on inside surface of the cover/door.

Type Code Number

Use the following to interpret the type code found on the identification label.

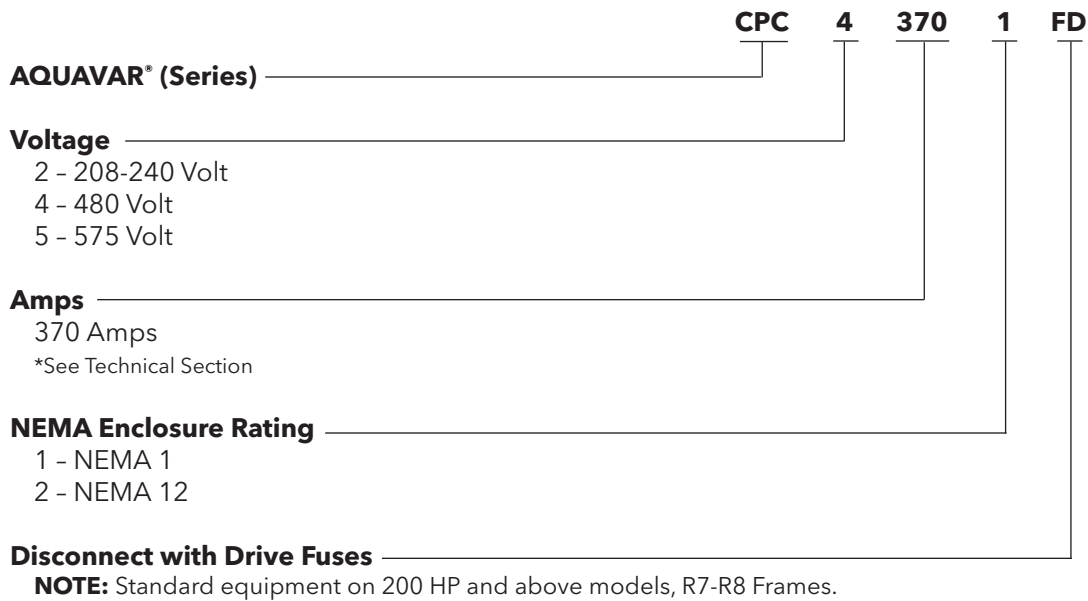

Options

* Consult factory for other options, if available. Not all combinations may be available.

Ratings and Frame Size

Charts in the "Ratings" sections of the Aquavar CPC User's Manual and this manual list technical specifications, and identify the drive's frame size.

NOTE! Some instructions in this document vary, depending on the drive's frame size. To read the Ratings table, you need the "Output current rating" entry from the type code (see above).

INSTALLATION

Suitable Mounting Location

For selecting a suitable mounting location for FD configurations, refer to:

- Preparing for installation in the Aquavar CPC User's Manual, and
- The Technical Data section of this manual for information on dimensions and weights.

Installing the Drive (Supplement to Aquavar CPC User's Manual - IM167)



WARNING! Metal shavings or debris in the enclosure can damage electrical equipment and create a hazardous condition. Where parts, such as conduit plates require cutting or drilling, first remove the part. If that is not practical, cover nearby electrical components to protect them from all shavings or debris.

Prepare the Mounting Location - R7 and R8

The Aquavar CPC should only be mounted where all of the requirements defined in "Preparing for Installation" are met.

Frame sizes R7 and R8 have mounting holes inside the enclosure base. See "NEMA 1 and 12, R7...R8 Mounting Dimensions" on page 28.

Where it is not possible to use either mounting hole at the back of the base, use an L-bracket at the top of the enclosure to secure the cabinet to a wall or to the back of another enclosure. Bolt the L-bracket to the enclosure using the lifting lug bolt hole on the top of the enclosure.

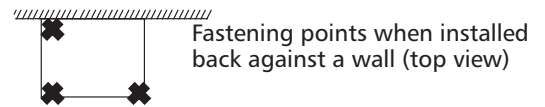
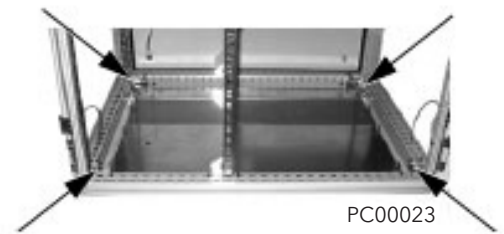

Fastening points when installed back against a wall (top view)

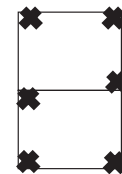

Fastening points when installed back against back

Fastening the cabinet at the top using L-brackets (side view)

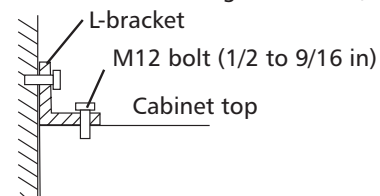

Remove Side Panels - R7 and R8 NEMA 1 and 12 Enclosures

Cabinet Door

1. To open the cabinet door, loosen the quarter-turn screws that hold the cabinet door closed.
2. Installation access is easier if these panels are kept off throughout the installation.

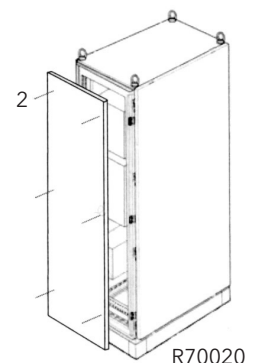

INSTALLATION

Mount the Drive

R7...R8

1. Use a hoist to move the cabinet into position.

NOTE! If the cabinet location does not provide access to the cabinet sides, be sure to re-mount side panels before positioning cabinet.



PC00003

Installing the Wiring (Supplement to Aquavar CPC User's Manual)



WARNING!

- Metal shavings or debris in the enclosure can damage electrical equipment and create a hazardous condition. Where parts, such as conduit plates require cutting or drilling, first remove the part. If that is not practical, cover nearby electrical components to protect them from all shavings or debris.
- Do not connect or disconnect input or output power wiring, or control wires, when power is applied.
- Never connect line voltage to drive output Terminals T1, T2 and T3.
- Do not make any voltage tolerance tests (Hi Pot or Megger) on any part of the unit. Disconnect motor wires before taking any measurements in the motor or motor wires.
- Make sure that power factor correction capacitors are not connected between the drive and the motor.

Wiring Requirements

Refer to the "Wiring Requirements" Section in the Aquavar CPC User's Manual. The requirements apply to all Aquavar CPC drives. In particular:

- Use separate, metal conduit runs for the following different classes of wiring:
 - Input power wiring
 - Motor wiring
 - Control/communications wiring
- Properly and individually ground the drive, the motor and cable shields.
- **Ground the pressure transducer** or piping back to the Aquavar chassis or common grounding point.

INSTALLATION

Wiring Overview

Power Connection - Standard Input Disconnect (R1...R6, Wall Mounted)

The following figures show the Standard Input Disconnect (wall mounted) wiring connection points. Refer to the Aquavar CPC User's Manual for control connections to the drive.

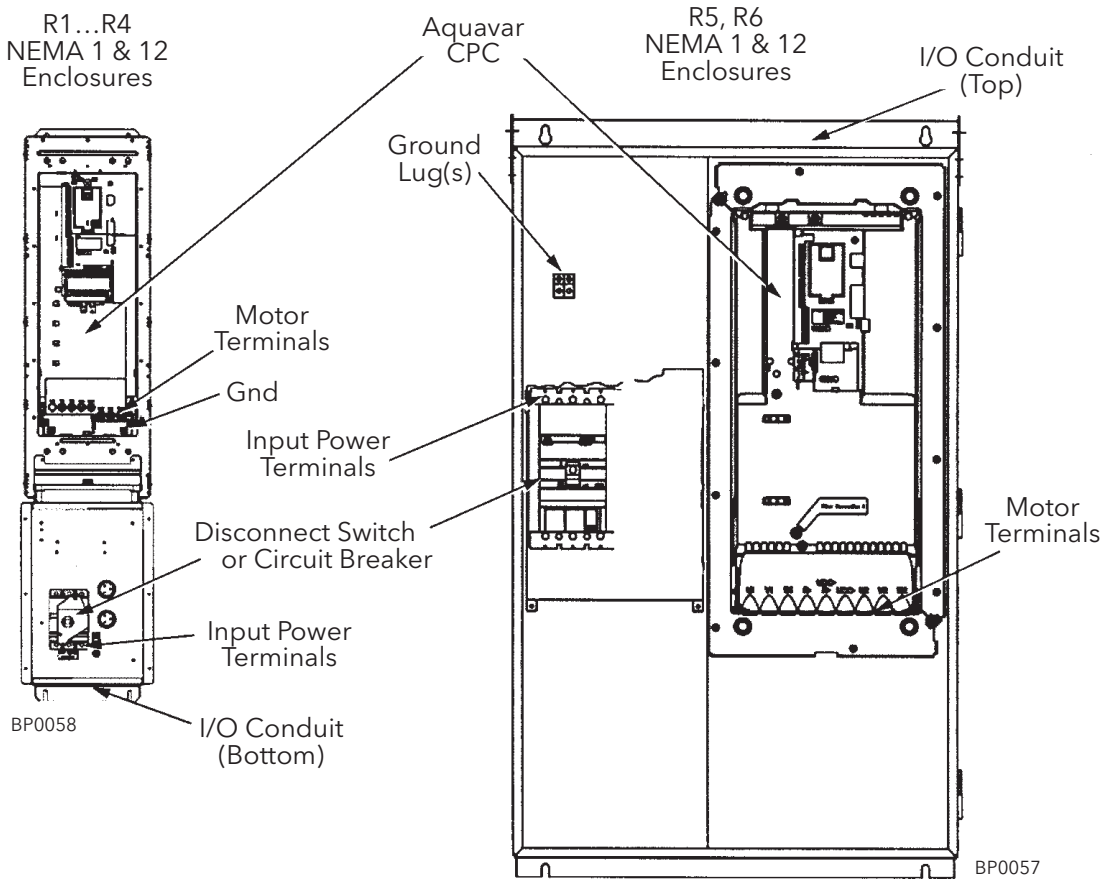

INSTALLATION

Power Connection - Standard Input Disconnect (R7...R8, Floor Mounted)

The R7 and R8 Aquavar CPC Standard Input Disconnect units are configured for wiring access from the top and include a removable conduit mounting plate. The following figure shows the Standard Input Disconnect (floor mounted) wiring connection points. Refer to the Aquavar CPC User's Manual for control connections to the drive.

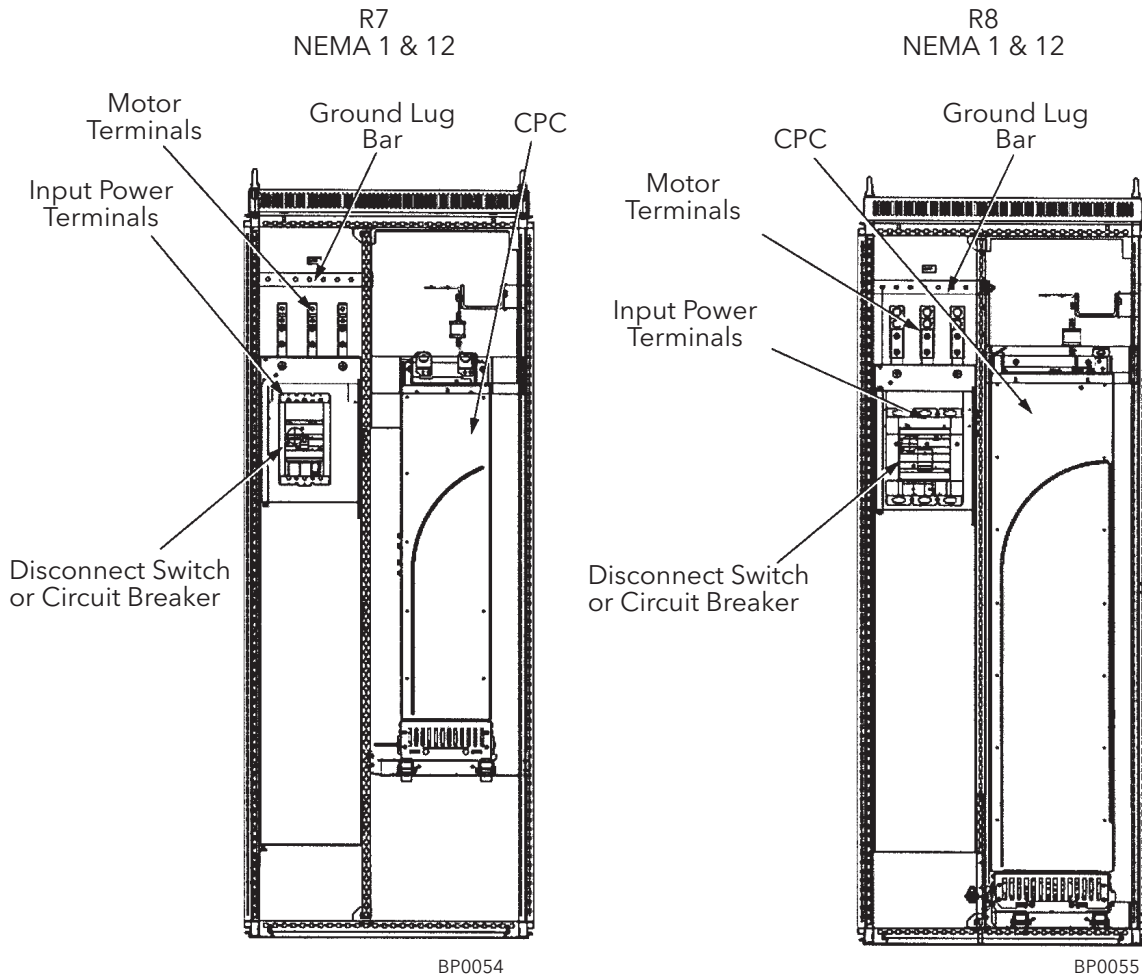

INSTALLATION

Install the Line Input Wiring

Line Input Connections - Standard Input Disconnect Configurations

Connect input power to the terminals of the disconnect switch or circuit breaker. Connect the equipment grounding conductor to the ground lug. The figure below shows the connection points for Standard Input Disconnect configurations.

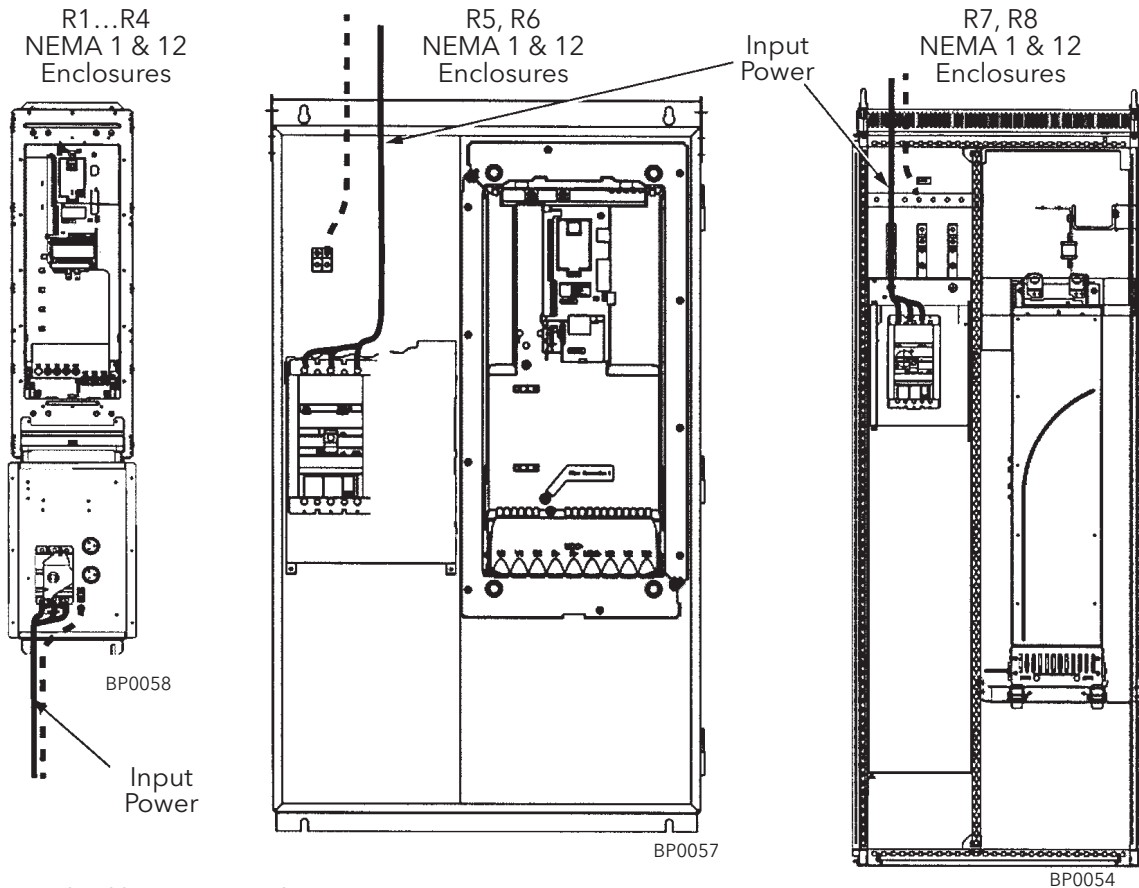

R7 shown.
R8 similar to R7.



WARNING! Check the motor and motor wiring insulation before connecting the Aquavar CPC to line power. Follow the procedure in the Aquavar CPC User's Manual. Before proceeding with the insulation resistance measurements, check that the Aquavar CPC is disconnected from incoming line power. Failure to disconnect line power could result in death or serious injury.

NOTE! For the remainder of the installation and start-up (motor and control wiring) refer to the Aquavar CPC User's Manual.

MAINTENANCE

Maintenance Intervals

If installed in an appropriate environment, the drive requires very little maintenance. This table lists the routine maintenance intervals recommended by CentriPro.

Maintenance	Configuration	Interval	Instruction
Check/replace R5/R6 enclosure inlet air filter	R5/R6 NEMA 12 enclosures	Check every 3 months. Replace as needed.	"Frame Sizes R5/R6 - Enclosure Inlet Air Filter" on page 16.
Check/replace R7/R8 enclosure inlet air filter	R7/R8 NEMA 12 enclosures	Check every 3 months. Replace as needed.	"Frame Sizes R7/R8 - NEMA 12 Enclosure Inlet Air Filter" on page 16.
Check/replace R7/R8 enclosure exhaust air filter	R7/R8 NEMA 12 enclosures	Check every 6 months. Replace as needed.	"Frame Sizes R7/R8 - NEMA 12 Enclosure Exhaust Filters" on page 18.
Check and clean heatsink	All	Depends on the dustiness of the environment (every 6...12 months)	See "Maintenance" in Aquavar CPC User's Manual.
Replace drive module fan	All	Every 6 years	See "Maintenance" in Aquavar CPC User's Manual.
Replace enclosure fan(s)	NEMA 12	Every 3 years	See "Frame Sizes R7/R8 - NEMA 12 Enclosures" on page 15. For other frame sizes, see "Maintenance" in Aquavar CPC User's Manual.
Change capacitor	Frame sizes R5 and R6	Every 10 years	See "Maintenance" in Aquavar CPC User's Manual.
Replace battery in the Assistant control panel	All	Every 10 years	See "Maintenance" in Aquavar CPC User's Manual.

Drive Module Fan Replacement

The drive module fan cools the heatsink. Fan failure can be predicted by the increasing noise from fan bearings and the gradual rise in the heatsink temperature in spite of heatsink cleaning. If the drive is operated in a critical part of a process, fan replacement is recommended once these symptoms start appearing. Replacement fans are available from the factory. Do not use other than CentriPro specified spare parts.

To monitor the running time of the cooling fan, see "Group 29: Maintenance Trig" in the Aquavar CPC Users's Manual.

Frame Sizes R7 and R8

Refer to the installation instructions supplied with the fan kit.

MAINTENANCE

Enclosure Fan Replacement - NEMA 12 Enclosures

NEMA 12 enclosures include an additional fan (or fans) to move air through the enclosure.

Frame Sizes R7/R8 - NEMA 12 Enclosures

The enclosure fan is located in the exhaust box on top of the NEMA 12 enclosure.

1. Remove the left and right filter frames of the exhaust fan box by lifting them upwards.
2. Disconnect the fan's electrical connector from the cabinet roof (top right Inside the cabinet).
3. Undo the four fastening screws at the corners of the fan frame. The screws are through bolts with nuts on the inside of the cabinet. (Do not drop the hardware into the drive).

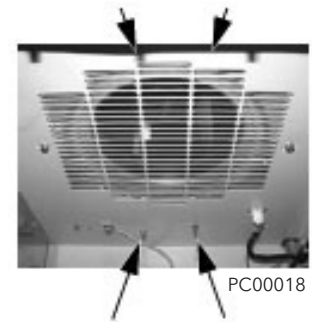
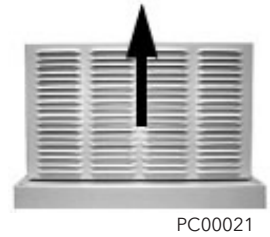

4. Remove the fan and fan frame as one unit.

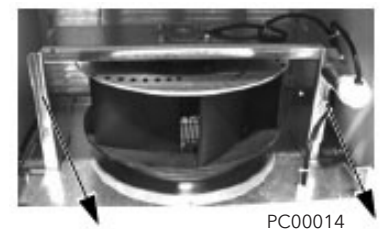

5. Disconnect the fan wiring and capacitor from the fan frame. Then remove the four screws attaching the fan to the fan frame. Remove the old fan.

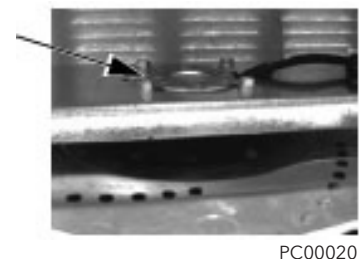

6. Install the new fan and capacitor with the replacement part for CentriPro in the reverse order of the above. Ensure the fan is centered on the velocity stack and rotates freely.



MAINTENANCE

Enclosure Air Filter Replacement - NEMA 12 Enclosures

Frame Sizes R5/R6 - Enclosure Inlet Air Filter

This procedure applies to disconnect configurations in R5 and R6 frame sizes with NEMA 12 enclosures. This filter is located at the bottom of the enclosure. Use the following procedure to check and replace filters.

1. On the enclosure, remove the screw holding the filter bracket in place.
2. Slide the filter bracket forward until the hooks on the bracket clear the slots on the enclosure base. This step allows the filter and bracket to drop free from the enclosure.

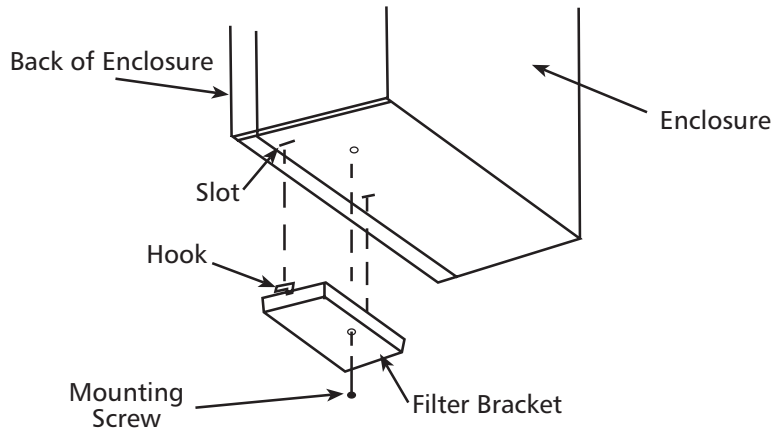

3. Lift the filter out of the filter bracket and replace as appropriate.
4. With the filter in the filter bracket, align the hooks on the bracket with the slots in the enclosure base, and press the hooks up into the slots.
5. Slide the filter bracket back, making sure that the hooks catch on the enclosure.
6. Replace the mounting screw. Tighten until the gasket on the bracket is about 50% compressed.

Frame Sizes R7/R8 - Nema 12 Enclosure Inlet Air Filter

The inlet air filter for the R7/R8 NEMA 12 enclosure is located in the enclosure front door.

1. While holding the top of the filter frame, pull up on the bottom of the frame. The filter frame will slide up approximately $\frac{3}{4}$ inch and can then safely removed by tilting away from the cabinet and lifting up.

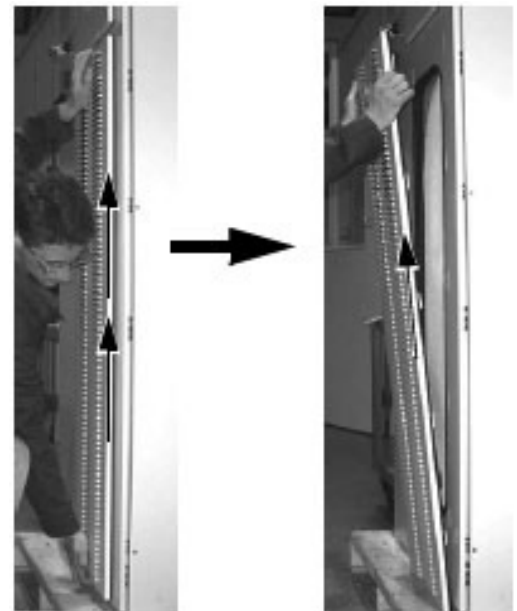

PC00015

PC00010

MAINTENANCE

2. Lay the filter frame on a flat work surface. Remove the 3 retaining brackets by squeezing the tabbed corners in towards the middle of each bracket until the bracket clears the filter frame. Save these brackets for replacement. Remove and inspect the filter.

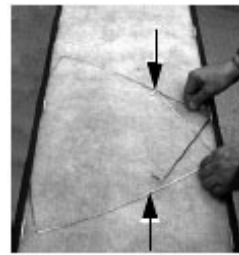

PC00009

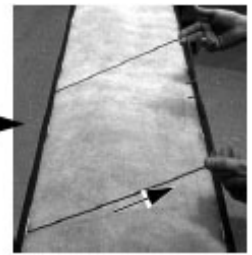

PC00007

3. Install the replacement filter. Be sure to tuck the filter into the groove around the entire filter frame. This is very important for proper installation.



PC00013

4. Reinstall the 3 filter restraining brackets. These will prevent the filter from being pulled out of the filter frame.

- Install the center bracket first.
- Install the 2nd bracket overlapping the center bracket by $\frac{1}{2}$ to the left.
- Install the 3rd bracket overlapping the center bracket by $\frac{1}{2}$ to the right.



PC00007

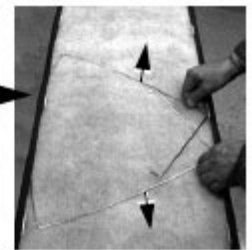

PC00009



1st filter retaining bracket



1st and 2nd filter retaining brackets



All 3 filter retaining brackets

5. Install the filter frame back to the cabinet door. Carefully align the mounting hooks to the slots in the cabinet door. The hooks should be pointing down. Press in at the center of the filter frame with your knee and gently press down with your hands at the top of the frame. The filter frame will slide down approximately $\frac{3}{4}$ inch and should be sealed securely to the door around the entire filter frame.



PC00006



PC00008

MAINTENANCE

Frame Sizes R7/R8 - NEMA 12 Enclosure Exhaust Filters

The exhaust filters in the R7/R8 NEMA 12 enclosure are located in the exhaust box at the top of the enclosure.

There are 2 filter frames attached to the exhaust box.

1. Remove each filter frame:

- Lift up on the filter frame until it slides approximately $\frac{3}{4}$ inch.
- Pull away from the exhaust box to remove.



PC00021

2. For each filter frame, remove the wire retainers that hold the filters in place:

- Lay the filter frames on a flat work surface.
- The wire retainers have a square "U" shape. Remove by squeezing the open end of the "U" towards the middle of the "square" until the retainer top (open end of "U") clears the filter frame.
- Save the retainers for reinstallation.

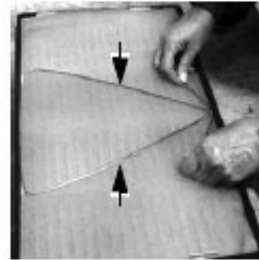

PC00001

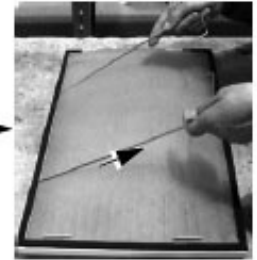

PC00019

3. Remove and inspect the filter.

4. Install clean filters.

NOTE! When installing DUSTLOK® filter media, the white side must face to outside of the cabinet, and the orange side faces in. Be sure to tuck the filter edges into the groove around the entire filter frame. This detail is very important for proper operation.

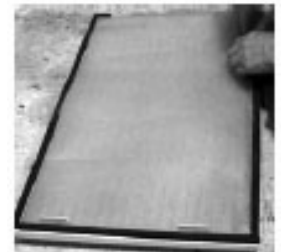

PC00022

5. Reinstall the filter restrainers.

- Insert the base of a retainer (bottom of "U" shape) into a filter frame channel.
- Squeeze the open end of the "U" until it clears the filter frame.
- Seat the open end of the "U" in the filter frame channel.
- Release the retainer to its relaxed, square shape.



PC00019

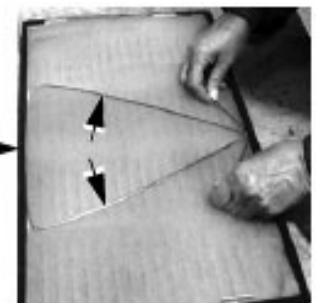

PC00001

6. Install each filter frame to the bonnet on top of the cabinet.

- Carefully align the frame's mounting hooks with the slots in the bonnet. (The hooks should be pointing down.)
- Press down at the top of the filter frame. (The filter frame slides down approximately $\frac{3}{4}$ inch).
- Check all around the filter frame for a secure seal to the exhaust box.



PC00012



PC00011

TECHNICAL DATA

The following tables provide current, horsepower, frame size and recommended cable sizes for the Aquavar CPC.

NOTE: THIS MANUAL SUPERCEDES PAGES 131-135 OF IM167R08.

CABLE SIZING/ RATINGS

208...240 Volt Drives

Voltage	Phase	GWT AQUAVAR CPC				Output Cable Min. AWG ¹	Input Cable Min. AWG ¹	Vendor Part Number
		NEMA 1 Base Model	Cont. Output Amps	Normal Duty Horsepower	Frame Size ²			
230	1	CPC20171	8.5	2	R1	14	14	ACS550-U1-017A-2+N2000+P918+X1555
		CPC20241	12	3	R2	14	10	ACS550-U1-024A-2+N2000+X1555
		CPC20311	15.5	5	R2	14	8	ACS550-U1-031A-2+N2000+X1555
		CPC20461	23	7.5	R3	12	6	ACS550-U1-046A-2+N2000+X1555
		CPC20591	29.5	10	R3	10	4	ACS550-U1-059A-2+N2000+X1555
		CPC20881	44.0	15	R4	8	2	ACS550-U1-088A-2+N2000+X1555
		CPC21141	57.0	20	R4	6	1/0	ACS550-U1-114A-2+N2000+X1555
		CPC21431	71.5	25	R6	4	3/0	ACS550-U1-143A-2+N2000+X1555
		CPC21781	89.0	30	R6	3	4/0	ACS550-U1-178A-2+N2000+X1555
		CPC22211	110.5	40	R6	2	300 MCM or 2 x 1/0	ACS550-U1-221A-2+N2000+X1555
		CPC22481	124.0	50	R6	1	350MCM or 2 x 2/0	ACS550-U1-248A-2+N2000+X1555
	3	CPC20121	11.8	3	R1	14	14	ACS550-U1-012A-2+N2000+P918+X1555
		CPC20171	16.7	5	R1	14	14	ACS550-U1-017A-2+N2000+P918+X1555
		CPC20241	24.2	7.5	R2	12	10	ACS550-U1-024A-2+N2000+X1555
		CPC20311	30.8	10	R2	10	8	ACS550-U1-031A-2+N2000+X1555
		CPC20461	46.2	15	R3	8	6	ACS550-U1-046A-2+N2000+X1555
		CPC20591	59.4	20	R3	6	4	ACS550-U1-059A-2+N2000+X1555
		CPC20751	74.8	25	R4	4	3	ACS550-U1-075A-2+N2000+X1555
		CPC20881	88.0	30	R4	3	2	ACS550-U1-088A-2+N2000+X1555
		CPC21141	114.0	40	R4	2	1/0	ACS550-U1-114A-2+N2000+X1555
		CPC21431	143.0	50	R6	1/0	3/0	ACS550-U1-143A-2+N2000+X1555
		CPC21781	178.0	60	R6	2/0	4/0	ACS550-U1-178A-2+N2000+X1555
		CPC22211	221.0	75	R6	4/0	300 MCM or 2 x 1/0	ACS550-U1-221A-2+N2000+X1555
CPC22481	248.0	100	R6	250MCM or 2 X 1	350MCM or 2 x 2/0	ACS550-U1-248A-2+N2000+X1555		

NOTE 1: Recommended AWG Size based on NEC table 310.16 , 40° C ambient, 90° C, UL type copper wire. For other wire sizes or types, consult local, state or NEC codes.

NOTE 2: Frame sizes R7 and R8, the Aquavar CPC will have multiple conductor terminals for each phase. Consult technical section (CABLE TERMINALS)

TECHNICAL DATA

The following table provides Aquavar CPC rating information, and recommended wire sizing for the input and output cables.

NOTE: THIS MANUAL SUPERCEDES PAGES 131-135 OF IM167R08.

CABLE SIZING/ RATINGS

380...480 Volt Drives

Voltage	Phase	GWT AQUAVAR CPC			Frame Size ²	Output Cable Min. AWG ¹	Input Cable Min. AWG ¹	Vendor Part Number
		NEMA 1 Base Model	Cont. Output Amps	Normal Duty Horsepower				
460	3	CPC40061	6.9	3	R1	14	14	ACS550-U1-06A9-4+N2000+P918+X1555
		CPC40081	8.8	5	R1	14	14	ACS550-U1-08A8-4+N2000+X1555
		CPC40121	11.9	7.5	R1	14	14	ACS550-U1-012A-4+N2000+P918+X1555
		CPC40151	15.4	10	R2	12	14	ACS550-U1-015A-4+N2000+X1555
		CPC40231	23	15	R2	12	10	ACS550-U1-023A-4+N2000+X1555
		CPC40311	31	20	R3	10	8	ACS550-U1-031A-4+N2000+X1555
		CPC40381	38	25	R3	8	8	ACS550-U1-038A-4+N2000+X1555
		CPC40441	44	30	R4	8	6	ACS550-U1-045A-4+N2000+X1555
		CPC40591	59	40	R4	6	4	ACS550-U1-059A-4+N2000+X1555
		CPC40721	72	50	R4	4	3	ACS550-U1-072A-4+N2000+X1555
		CPC40771	77	60	R5	4	3	ACS550-U1-078A-4+N2000+X1555
		CPC40961	96	75	R5	3	1	ACS550-U1-097A-4+N2000+X1555
		CPC41241	124	100	R6	1	1/0	ACS550-U1-125A-4+N2000+X1555
		CPC41571	157	125	R6	2/0	3/0	ACS550-U1-157A-4+N2000+X1555
		CPC41801	180	150	R6	3/0	4/0	ACS550-U1-180A-4+N2000+X1555
		CPC42451	245	200	R7	300MCM or 2 X 1/0	350MCM or 2 X 2/0	ACS550-U1-246A-4+N2000+X1555
		CPC43161	316	250	R7	500MCM or 2 X 3/0	2 X 3/0	ACS550-PC-316A-4+N2000+X1555
		CPC43681	368	300	R8	600MCM or 2 X 4/0 or 3 X 1/0	2 X 4/0	ACS550-PC-368A-4+N2000+X1555
		CPC44141	414	350	R8	2 X 250MCM or 3 X 2/0	2 X 300MCM	ACS550-PC-414A-4+N2000+X1555
		CPC44861	486	400	R8	2 X 300MCM or 3 X 3/0	2 X 350MCM	ACS550-PC-486A-4+N2000+X1555
CPC45261	526	450	R8	2 X 350MCM or 3 X 4/0	2 X 500MCM	ACS550-U2-526A-4+N2000+X1555		
CPC46021	602	500	R8	2 X 500MCM or 3 X 250MCM	2 X 500MCM or 3 X 250MCM	ACS550-U2-602A-4+N2000+X1555		
CPC46451	645	550	R8	2 X 500MCM or 3 X 250MCM	2 X 500MCM or 3 X 250MCM	ACS550-U2-645A-4+N2000+X1555		

NOTE 1: Recommended AWG Size based on NEC table 310.16 , 40° C ambient, 90° C, UL type copper wire. For other wire sizes or types, consult local, state or NEC codes.

NOTE 2: Frame sizes R7 and R8, the Aquavar CPC will have multiple conductor terminals for each phase. Consult technical section (CABLE TERMINALS) for max. wire diameter and torque values. For submersible motors consult motor manufacturer on recommended wire type and size based on lead length and amperage.

TECHNICAL DATA

The following tables provide current, horsepower, frame size and recommended cable sizes for the Aquavar CPC.

NOTE: THIS MANUAL SUPERCEDES PAGES 131-135 OF IM167R08.

CABLE SIZING/ RATINGS

600 Volt Drives

Voltage	Phase	GWT AQUAVAR CPC				Output Cable Min. AWG ¹	Input Cable Min. AWG ¹	Vendor Part Number
		NEMA 1 Base Model	Cont. Output Amps	Normal Duty Horsepower	Frame Size ²			
460	3	CPC50031	2.7	2	R2	14	14	ACS550-U1-02A7-6+N2000+X1555
		CPC50041	3.9	3	R2	14	14	ACS550-U1-03A9-6+N2000+X1555
		CPC50061	6.1	5	R2	14	14	ACS550-U1-06A1-6+N2000+X1555
		CPC50091	9	7.5	R2	14	14	ACS550-U1-09A0-6+N2000+X1555
		CPC50111	11	10	R2	14	14	ACS550-U1-011A-6+N2000+X1555
		CPC50171	17	15	R2	14	14	ACS550-U1-017A-6+N2000+X1555
		CPC50221	22	20	R3	12	10	ACS550-U1-022A-6+N2000+X1555
		CPC50271	27	25	R3	10	10	ACS550-U1-027A-6+N2000+X1555
		CPC50321	32	30	R4	10	8	ACS550-U1-032A-6+N2000+X1555
		CPC50411	41	40	R4	8	6	ACS550-U1-041A-6+N2000+X1555
		CPC50521	52	50	R4	6	6	ACS550-U1-052A-6+N2000+X1555
		CPC50621	62	60	R4	6	4	ACS550-U1-062A-6+N2000+X1555
		CPC50771	77	75	R6	4	3	ACS550-U1-077A-6+N2000+X1555
		CPC50991	99	100	R6	3	1	ACS550-U1-099A-6+N2000+X1555
		CPC51251	125	125	R6	2	2/0	ACS550-U1-125A-6+N2000+X1555
CPC51441	144	150	R6	1	3/0	ACS550-U1-144A-6+N2000+X1555		

NOTE 1: Recommended AWG Size based on NEC table 310.16 , 40° C ambient, 90° C, UL type copper wire. For other wire sizes or types, consult local or Provincial codes.

NOTE 2: Terminal block for input voltage and output motor voltage have diameter limits. Consult technical section (CABLE TERMINALS) for max. wire diameter and torque values.

For submersible motor applications refer to motor manufacturers recommendations based on lead length and voltage drop.

TECHNICAL DATA

The following table provides Aquavar CPC rating information, and recommended fuse sizing for the input short circuit protection. Branch circuit protection must be provided by the end user, contractor or distributor. Sized according to local or applicable NEC codes.

FUSE SIZING/ RATINGS

208...240 Volt Drives

Voltage	Phase	GWT AQUAVAR CPC				Input Current Amps	Fuse Type ³ JJN	Vendor Part Number
		NEMA 1 Base Model	Cont. Output Amps	Normal Duty Horsepower	Frame Size			
230	1	CPC20171	8.5	2	R1	21.3	25	ACS550-U1-017A-2+N2000+P918+X1555
		CPC20241	12	3	R2	30.0	30	ACS550-U1-024A-2+N2000+X1555
		CPC20311	15.5	5	R2	38.8	40	ACS550-U1-031A-2+N2000+X1555
		CPC20461	23	7.5	R3	57.5	60	ACS550-U1-046A-2+N2000+X1555
		CPC20591	29.5	10	R3	73.8	80	ACS550-U1-059A-2+N2000+X1555
		CPC20881	44.0	15	R4	110.0	110	ACS550-U1-088A-2+N2000+X1555
		CPC21141	57.0	20	R4	142.5	150	ACS550-U1-114A-2+N2000+X1555
		CPC21431	71.5	25	R6	178.8	200	ACS550-U1-143A-2+N2000+X1555
		CPC21781	89.0	30	R6	222.5	225	ACS550-U1-178A-2+N2000+X1555
		CPC22211	110.5	40	R6	276.3	300	ACS550-U1-221A-2+N2000+X1555
	CPC22481	124.0	50	R6	310.0	350	ACS550-U1-248A-2+N2000+X1555	
	3	CPC20121	11.8	3	R1	13.6	15	ACS550-U1-012A-2+N2000+P918+X1555
		CPC20171	16.7	5	R1	19.2	25	ACS550-U1-017A-2+N2000+P918+X1555
		CPC20241	24.2	7.5	R2	27.8	30	ACS550-U1-024A-2+N2000+X1555
		CPC20311	30.8	10	R2	35.4	40	ACS550-U1-031A-2+N2000+X1555
		CPC20461	46.2	15	R3	53.1	60	ACS550-U1-046A-2+N2000+X1555
		CPC20591	59.4	20	R3	68.3	80	ACS550-U1-059A-2+N2000+X1555
		CPC20751	74.8	25	R4	86.0	100	ACS550-U1-075A-2+N2000+X1555
		CPC20881	88.0	30	R4	101.2	110	ACS550-U1-088A-2+N2000+X1555
		CPC21141	114.0	40	R4	131.1	150	ACS550-U1-114A-2+N2000+X1555
		CPC21431	143.0	50	R6	164.5	200	ACS550-U1-143A-2+N2000+X1555
		CPC21781	178.0	60	R6	204.7	250	ACS550-U1-178A-2+N2000+X1555
CPC22211		221.0	75	R6	254.2	300	ACS550-U1-221A-2+N2000+X1555	
CPC22481	248.0	100	R6	285.2	350	ACS550-U1-248A-2+N2000+X1555		

NOTE 3: UL Class T fuses are recommended for short circuit protection. Very fast acting Bussmann* T-tron type JJN and JJS are shown in the Aquavar CPC tables. Other manufacturers are acceptable if they meet fuse requirements.

TECHNICAL DATA

The following table provides Aquavar CPC rating information, and recommended fuse sizing for the input short circuit protection. Branch circuit protection must be provided by the end user, contractor or distributor. Sized according to local or applicable NEC codes. **NOTE:** THIS MANUAL SUPERCEDES PAGES 131-135 OF IM167R08.

FUSE SIZING/ RATINGS

380...480 Volt Drives

Voltage	Phase	GWT AQUAVAR CPC			Frame Size	Input Current Amps	Fuse Type ³ JJS	Vendor Part Number
		NEMA 1 Base Model	Cont. Output Amps	Normal Duty Horsepower				
460	3	CPC40061	6.9	3	R1	7.9	10	ACS550-U1-06A9-4+N2000+P918+X1555
		CPC40081	8.8	5	R1	10.1	15	ACS550-U1-08A8-4+N2000+X1555
		CPC40121	11.9	7.5	R1	13.7	15	ACS550-U1-012A-4+N2000+P918+X1555
		CPC40151	15.4	10	R2	17.7	20	ACS550-U1-015A-4+N2000+X1555
		CPC40231	23	15	R2	26.5	30	ACS550-U1-023A-4+N2000+X1555
		CPC40311	31	20	R3	35.7	40	ACS550-U1-031A-4+N2000+X1555
		CPC40381	38	25	R3	43.7	50	ACS550-U1-038A-4+N2000+X1555
		CPC40441	44	30	R4	50.6	60	ACS550-U1-045A-4+N2000+X1555
		CPC40591	59	40	R4	67.9	80	ACS550-U1-059A-4+N2000+X1555
		CPC40721	72	50	R4	82.8	90	ACS550-U1-072A-4+N2000+X1555
		CPC40771	77	60	R5	88.6	100	ACS550-U1-078A-4+N2000+X1555
		CPC40961	96	75	R5	110.4	125	ACS550-U1-097A-4+N2000+X1555
		CPC41241	124	100	R6	142.6	175	ACS550-U1-125A-4+N2000+X1555
		CPC41571	157	125	R6	180.6	200	ACS550-U1-157A-4+N2000+X1555
		CPC41801	180	150	R6	207.0	250	ACS550-U1-180A-4+N2000+X1555
		CPC42451	245	200	R7	281.8	300	ACS550-U1-246A-4+N2000+X1555
		CPC43161	316	250	R7	363.4	400	ACS550-PC-316A-4+N2000+X1555
		CPC43681	368	300	R8	423.2	450	ACS550-PC-368A-4+N2000+X1555
		CPC44141	414	350	R8	476.1	500	ACS550-PC-414A-4+N2000+X1555
		CPC44861	486	400	R8	558.9	600	ACS550-PC-486A-4+N2000+X1555
CPC45261	526	450	R8	604.9	600	ACS550-U2-526A-4+N2000+X1555		
CPC46021	602	500	R8	692.3	800	ACS550-U2-602A-4+N2000+X1555		
CPC46451	645	550	R8	741.8	800	ACS550-U2-645A-4+N2000+X1555		

NOTE 3: UL Class T fuses are recommended for short circuit protection. Very fast acting Bussmann* T-tron type and JJS are shown in the Aquavar CPC tables. Other manufacturers are acceptable if they meet fuse requirements.

TECHNICAL DATA

The following table provides Aquavar CPC rating information, and recommended fuse sizing for the input short circuit protection. Branch circuit protection must be provided by the end user, contractor or distributor. Sized according to local or applicable NEC codes. **NOTE:** THIS MANUAL SUPERCEDES PAGES 131-135 OF IM167R08.

FUSE SIZING/ RATINGS

600 Volt Drives

Voltage	Phase	GWT AQUAVAR CPC			Frame Size	Input Current Amps	Fuse Type ³ JJS	Vendor Part Number
		NEMA 1 Base Model	Cont. Output Amps	Normal Duty Horsepower				
575	3	CPC50031	2.7	2	R2	2.7	10	ACS550-U1-02A7-6+N2000+X1555
		CPC50041	3.9	3	R2	3.9	10	ACS550-U1-03A9-6+N2000+X1555
		CPC50061	6.1	5	R2	6.1	10	ACS550-U1-06A1-6+N2000+X1555
		CPC50091	9	7.5	R2	9	15	ACS550-U1-09A0-6+N2000+X1555
		CPC50111	11	10	R2	11	15	ACS550-U1-011A-6+N2000+X1555
		CPC50171	17	15	R2	17	25	ACS550-U1-017A-6+N2000+X1555
		CPC50221	22	20	R3	22	25	ACS550-U1-022A-6+N2000+X1555
		CPC50271	27	25	R3	27	40	ACS550-U1-027A-6+N2000+X1555
		CPC50321	32	30	R4	32	40	ACS550-U1-032A-6+N2000+X1555
		CPC50411	41	40	R4	41	50	ACS550-U1-041A-6+N2000+X1555
		CPC50521	52	50	R4	52	60	ACS550-U1-052A-6+N2000+X1555
		CPC50621	62	60	R4	62	80	ACS550-U1-062A-6+N2000+X1555
		CPC50771	77	75	R6	77	100	ACS550-U1-077A-6+N2000+X1555
		CPC50991	99	100	R6	99	150	ACS550-U1-099A-6+N2000+X1555
		CPC51251	125	125	R6	125	175	ACS550-U1-125A-6+N2000+X1555
CPC51441	144	150	R6	144	200	ACS550-U1-144A-6+N2000+X1555		

NOTE 3: UL Class T fuses are recommended for short circuit protection. Very fast acting Bussmann* T-tron type JJS are shown in the Aquavar CPC tables. Other manufacturers are acceptable if they meet fuse requirements.

TECHNICAL DATA

Ratings (Supplement to Aquavar CPC User's Manual - IM167)

NOTE! The ratings listed below are exceptions to the ratings listed in the Aquavar CPC User's Manual.

Ratings, 380...480 Volt Drives

Type Code	Valid up to 40°C (104 °F)				Frame Size	Vendor Part Number
	Normal Use		Heavy-Duty Use			
AQUAVAR CPC-FD - see below	I_{2N} A	P_N HP	I_{2hd} A	P_{hd} HP		
CPC4245xFD	245	200	192	150	R7	ACS550-PD-246A-4+N2000+X1555
CPC4316xFD	316	250	240	200	R8	ACS550-PD-316A-4+N2000+X1555
CPC4368xFD	368	300	302	250	R8	ACS550-PD-368A-4+N2000+X1555
CPC4414xFD	414	350	368	300	R8	ACS550-PD-414A-4+N2000+X1555
CPC4486xFD	486	400	414	350	R8	ACS550-PD-486A-4+N2000+X1555
CPC45261FD	526	450	477	400	R8	ACS550-PD-526A-4+N2000+X1555
CPC46021FD	602	500	515	450	R8	ACS550-PD-602A-4+N2000+X1555
CPC46451FD	645	550	590	500	R8	ACS550-U2-645A-4+N2000+X1555

NOTE: I_{2N} = Motor current draw normal
 P_N = Normal rated power
 I_{2hd} = Heavy-duty current rating
 P_{hd} = Heavy-duty NEMA power rating

TECHNICAL DATA

Input Power Connections (Supplement to Aquavar CPC User's Manual)

Fuses

NOTE! Although fuses listed are similar in functional characteristics to fuses listed in the Aquavar CPC User's Manual, physical characteristics may differ. Fuses from other manufacturers can be used if they meet the functional characteristics of those in these tables.

Drive input fuses are provided to disconnect the drive from power in the event that a component fails in the drive's power circuitry.

208...240 Volt Fuses

208 ... 240 Volt		Base Drive Frame Size	Drive Input Fuse Ratings		Vendor Part Number
HP	Identification		Amps (600V)	Bussmann Type	
1	CPC2004xFD	R1	15	KTK-R-15	ACS550-PD-04A6-2+N2000+P918+X1555
2	CPC2007xFD	R1	15	KTK-R-15	ACS550-PD-07A5-2+N2000+X1555
3	CPC2012xFD	R1	15	KTK-R-15	ACS550-PD-012A-2+N2000+X1555
5	CPC2017xFD	R1	30	KTK-R-30	ACS550-PD-017A-2+N2000+X1555
7.5	CPC2024xFD	R2	30	KTK-R-30	ACS550-PD-024A-2+N2000+X1555
10	CPC2031xFD	R2	50	JJS-50	ACS550-PD-031A-2+N2000+X1555
15	CPC2046xFD	R3	80	JJS-80	ACS550-PD-046A-2+N2000+X1555
20	CPC2059xFD	R3	80	JJS-80	ACS550-PD-059A-2+N2000+X1555
25	CPC2075xFD	R4	100	JJS-100	ACS550-PD-075A-2+N2000+X1555
30	CPC2088xFD	R4	125	170M1368	ACS550-PD-088A-2+N2000+X1555
40	CPC2114xFD	R4	160	170M1369	ACS550-PD-114A-2+N2000+X1555
50	CPC2143xFD	R6	200	170M1370	ACS550-PD-143A-2+N2000+X1555
60	CPC2178xFD	R6	250	170M1371	ACS550-PD-178A-2+N2000+X1555
75	CPC2221xFD	R6	315	170M1372	ACS550-PD-222A-2+N2000+X1555
100	CPC2248xFD	R6	315	170M1372	ACS550-PD-248A-2+N2000+X1555

NOTE: "x" represents both NEMA 1 and NEMA 12 enclosures.

TECHNICAL DATA

380...480 Volt Fuses

380 ... 480 Volt		Base Drive Frame Size	Drive Input Fuse Ratings		Vendor Part Number
HP	Identification		Amps (600V)	Bussmann Type	
3	CPC4006xFD	R1	15	KTK-R-15	ACS550-PD-06A9-4+N2000+X1555
5	CPC4008xFD	R1	15	KTK-R-15	ACS550-PD-08A8-4+N2000+X1555
7.5	CPC4012xFD	R1	15	KTK-R-15	ACS550-PD-012A-4+N2000+X1555
10	CPC4015xFD	R2	30	KTK-R-30	ACS550-PD-015A-4+N2000+X1555
15	CPC4023xFD	R2	30	KTK-R-30	ACS550-PD-023A-4+N2000+X1555
20	CPC4031xFD	R3	50	JJS-50	ACS550-PD-031A-4+N2000+X1555
25	CPC4038xFD	R3	50	JJS-50	ACS550-PD-038A-4+N2000+X1555
30	CPC4044xFD	R3	100	JJS-100	ACS550-PD-045A-4+N2000+X1555
40	CPC4059xFD	R4	100	JJS-100	ACS550-PD-059A-4+N2000+X1555
50	CPC4072xFD	R4	100	JJS-100	ACS550-PD-072A-4+N2000+X1555
60	CPC4077xFD	R5	125	170M1368	ACS550-PD-078A-4+N2000+X1555
75	CPC4096xFD	R5	125	170M1368	ACS550-PD-097A-4+N2000+X1555
100	CPC4124xFD	R6	160	170M1369	ACS550-U1-125A-4+B055+N2000+X1555
125	CPC4157xFD	R6	200	170M1370	ACS550-PD-157A-4+N2000+X1555
150	CPC4180xFD	R6	250	170M1371	ACS550-PD-180A-4+N2000+X1555
200	CPC4245xFD	R7	400	JJS-400	ACS550-PD-246A-4+N2000+X1555
250	CPC4316xFD	R8	400	JJS-400	ACS550-PD-316A-4+N2000+X1555
300	CPC4368xFD	R8	400	JJS-400	ACS550-PD-368A-4+N2000+X1555
350	CPC4414xFD	R8	600	JJS-600	ACS550-PD-414A-4+N2000+X1555
400	CPC4486xFD	R8	600	JJS-600	ACS550-PD-486A-4+N2000+X1555
450	CPC4526xFD	R8	800	JJS-800	ACS550-U2-526A-4+N2000+X1555
500	CPC4602xFD	R8	800	JJS-800	ACS550-U2-602A-4+N2000+X1555
550	CPC4645xFD	R8	800	JJS-800	ACS550-U2-645A-4+N2000+X1555

NOTE: "x" represents both NEMA 1 and NEMA 12 enclosures.

TECHNICAL DATA

500...600 Volt Fuses

500 ... 600 Volt		Base Drive Frame Size	Drive Input Fuse Ratings		Vendor Part Number
HP	Identification		Amps (600V)	Bussmann Type	
2	CPC5002xFD	R2	15	KTK-R-15	ACS550-PD-02A1-6+N2000+X1555
3	CPC5004xFD	R2	15	KTK-R-15	ACS550-PD-04A1-6+N2000+X1555
5	CPC5006xFD	R2	15	KTK-R-15	ACS550-PD-06A1-6+N2000+X1555
7.5	CPC5009xFD	R2	15	KTK-R-15	ACS550-PD-09A1-6+N2000+X1555
10	CPC5011xFD	R2	30	KTK-R-30	ACS550-PD-11A1-6+N2000+X1555
15	CPC5017xFD	R2	30	KTK-R-30	ACS550-PD-17A1-6+N2000+X1555
20	CPC5022xFD	R3	50	JJS-50	ACS550-PD-22A1-6+N2000+X1555
25	CPC5027xFD	R3	50	JJS-50	ACS550-PD-27A1-6+N2000+X1555
30	CPC5032xFD	R4	100	JJS-100	ACS550-PD-32A1-6+N2000+X1555
40	CPC5041xFD	R4	100	JJS-100	ACS550-PD-41A1-6+N2000+X1555
50	CPC5052xFD	R4	100	JJS-100	ACS550-PD-52A1-6+N2000+X1555
60	CPC5062xFD	R4	100	JJS-100	ACS550-PD-62A1-6+N2000+X1555
75	CPC5077xFD	R6	125	170M1368	ACS550-PD-77A1-6+N2000+X1555
100	CPC5099xFD	R6	125	170M1368	ACS550-PD-99A1-6+N2000+X1555
125	CPC5125xFD	R6	160	170M1369	ACS550-PD-125A1-6+N2000+X1555
150	CPC5144xFD	R6	200	170M1370	ACS550-PD-144A1-6+N2000+X1555

NOTE: "x" represents both NEMA 1 and NEMA 12 enclosures.

Input Power Cables / Wiring - R7/R8

NEC			
Based on:			
• NEC Table 310-16 for copper wires		• 40 °C (104 °F) ambient temperature	
• 90 °C (194 °F) wire insulation		• Copper cables with concentric copper shield	
• Not more than three current-carrying conductors in raceway or cable, or earth (directly buried).			
Max Load Current (A)	Cu Wire Size (AWG/kcmil)	Max Load Current (A)	Cu Wire Size (AWG/kcmil)
345	400 MCM or 2 x 2/0	474	2 x 250
391	500 MCM or 2 x 3/0	534	2 x 300
410	2 x 3/0	615	2 x 350
465	2 x 4/0	711	2 x 500

TECHNICAL DATA

Drive's Power Connection Terminals (Supplement to Aquavar CPC User's Manual)

The following tables show maximum wire size and required tightening torque for incoming power and motor terminals, and grounding terminal lug information.

208...240 Volt, Terminals

208 ... 240 Volt		Frame Size	Power Wiring Data				Vendor Part Number		
HP	Type Code		Circuit Breaker	Disconnect Switch	Motor Terminals	Ground Lugs NEMA 1 & 12			
1	CPC2004xFD	R1	#10 35 in-lbs	#10 7 in-lbs	#10 12 in-lbs	#10 35 in-lbs	ACS550-PD-04A6-2+N2000+P918+X1555		
2	CPC2007xFD	R1					ACS550-PD-07A5-2+N2000+X1555		
3	CPC2012xFD	R1					ACS550-PD-012A-2+N2000+X1555		
5	CPC2017xFD	R1					ACS550-PD-017A-2+N2000+X1555		
7.5	CPC2024xFD	R2	#6 45 in-lbs	#8 7 in-lbs	#6 12 in-lbs	#3 50 in-lbs	ACS550-PD-024A-2+N2000+X1555		
10	CPC2031xFD	R2					ACS550-PD-031A-2+N2000+X1555		
15	CPC2046xFD	R3	#3 50 in-lbs	#4 18 in-lbs	#3 24 in-lbs	#3 50 in-lbs	ACS550-PD-046A-2+N2000+X1555		
20	CPC2059xFD	R3					ACS550-PD-059A-2+N2000+X1555		
25	CPC2075xFD	R4	#1 50 in-lbs	#1 55 in-lbs	#1 48 in-lbs	#2 50 in-lbs	ACS550-PD-075A-2+N2000+X1555		
30	CPC2088xFD	R4					#1/0 70 in-lbs	#1/0 48 in-lbs	ACS550-PD-088A-2+N2000+X1555
40	CPC2114xFD	R4					350 MCM 274 in-lbs		300 MCM 275 in-lbs
50	CPC2143xFD	R6	350 MCM 360 in-lbs	350 MCM 360 in-lbs	#2 250 in-lbs	ACS550-PD-143A-2+N2000+X1555			
60	CPC2178xFD	R6				ACS550-PD-178A-2+N2000+X1555			
75	CPC2221xFD	R6				2 x 250 MCM 274 in-lbs	2 x 250 MCM 275 in-lbs	ACS550-PD-222A-2+N2000+X1555	
100	CPC2248xFD	R6	ACS550-PD-248A-2+N2000+X1555						

NOTE: "x" represents both NEMA 1 and NEMA 12.

TECHNICAL DATA

380...480 Volt, Terminals

380 ... 480 Volt		Frame Size	Power Wiring Data				Vendor Part Number	
HP	Type Code		Circuit Breaker	Disconnect Switch	Motor Terminals	Ground Lugs NEMA 1 & 12		
3	CPC4006xFD	R1	#10 35 in-lbs	#10 7 in-lbs	#10 12 in-lbs	#10 35 in-lbs	ACS550-PD-06A9-4 +N2000+X1555	
5	CPC4008xFD	R1					ACS550-PD-08A8-4 +N2000+X1555	
7.5	CPC4012xFD	R1					ACS550-PD-012A-4 +N2000+X1555	
10	CPC4015xFD	R2	#6 45 in-lbs	#8 7 in-lbs	#6 12 in-lbs	#6 35 in-lbs	ACS550-PD-015A-4 +N2000+X1555	
15	CPC4023xFD	R2					ACS550-PD-023A-4 +N2000+X1555	
20	CPC4031xFD	R3	#3 50 in-lbs	#4 18 in-lbs	#3 24 in-lbs	#3 50 in-lbs	ACS550-PD-031A-4 +N2000+X1555	
25	CPC4038xFD	R3					ACS550-PD-038A-4 +N2000+X1555	
30	CPC4044xFD	R4					ACS550-PD-045A-4 +N2000+X1555	
40	CPC4059xFD	R4	#1 50 in-lbs	#1 55 in-lbs	#1 48 in-lbs	#1 50 in-lbs	ACS550-PD-059A-4 +N2000+X1555	
50	CPC4072xFD	R4					ACS550-PD-072A-4 +N2000+X1555	
60	CPC4077xFD	R4					#1 62 in-lbs	ACS550-PD-078A-4 +N2000+X1555
75	CPC4096xFD	R5	350 MCM 274 in-lbs	#1/0 70 in-lbs	#1/0 48 in-lbs	3 x #3/0 250 in-lbs	ACS550-PD-097A-4 +N2000+X1555	
100	CPC4124xFD	R6					#2/0 132 in-lbs	ACS550-U1-125A-4 +B055+N2000+X1555
125	CPC4157xFD	R6					300 MCM 275 in-lbs	ACS550-PD-157A-4 +N2000+X1555
150	CPC4180xFD	R6	2 x 250 MCM 274 in-lbs	2 x 250 MCM 274 in-lbs	350 MCM 360 in-lbs	5 Bus Bar Holes (13/32" Bolts)	ACS550-PD-180A-4 +N2000+X1555	
200	CPC4245xFD	R7					ACS550-PD-246A-4 +N2000+X1555	
250	CPC4316xFD	R8	2 x 500 MCM 274 in-lbs	2 x 500 MCM 274 in-lbs	2 x 500 MCM 500 in-lbs	5 Bus Bar Holes (13/32" Bolts)	ACS550-PD-316A-4 +N2000+X1555	
300	CPC4368xFD	R8					ACS550-PD-368A-4 +N2000+X1555	
350	CPC4414xFD	R8					ACS550-PD-414A-4 +N2000+X1555	
400	CPC4486xFD	R8	3 x 400 MCM 375 in-lbs	3 x 400 MCM 375 in-lbs	2 x 600 MCM 500 in-lbs	5 Bus Bar Holes (13/32" Bolts)	ACS550-PD-486A-4 +N2000+X1555	
450	CPC4526xFD	R8					ACS550-U2-526A-4 +N2000+X1555	
500	CPC4602xFD	R8					ACS550-U2-602A-4 +N2000+X1555	
550	CPC4645xFD	R8	3 x 400 MCM				ACS550-U2-645A-4 +N2000+X1555	

NOTE: "x" represents both NEMA 1 and NEMA 12.

TECHNICAL DATA

500...600 Volt, Terminals

500 ... 600 Volt		Frame Size	Power Wiring Data				Vendor Part Number
HP	Type Code		Circuit Breaker	Disconnect Switch	Motor Terminals	Ground Lugs NEMA 1 & 12	
2	CPC5002xFD	R2	#6 62 in-lbs	#8 7 in-lbs	#6 12 in-lbs	#6 35 in-lbs	ACS550-PD-02A1-6+N2000+X1555
3	CPC5004xFD	R2					ACS550-PD-04A1-6+N2000+X1555
5	CPC5006xFD	R2					ACS550-PD-06A1-6+N2000+X1555
7.5	CPC5009xFD	R2					ACS550-PD-09A1-6+N2000+X1555
10	CPC5011xFD	R2					ACS550-PD-11A1-6+N2000+X1555
15	CPC5017xFD	R2					ACS550-PD-17A1-6+N2000+X1555
20	CPC5022xFD	R3	#3 62 in-lbs	#3 24 in-lbs	#3 50 in-lbs	ACS550-PD-22A1-6+N2000+X1555	
25	CPC5027xFD	R3				ACS550-PD-27A1-6+N2000+X1555	
30	CPC5032xFD	R4	#1 62 in-lbs	#4 18 in-lbs	#1 48 in-lbs	#2 50 in-lbs	ACS550-PD-32A1-6+N2000+X1555
40	CPC5041xFD	R4		ACS550-PD-41A1-6+N2000+X1555			
50	CPC5052xFD	R4		#1 55 in-lbs			ACS550-PD-52A1-6+N2000+X1555
60	CPC5062xFD	R4		#1 62 in-lbs			ACS550-PD-62A1-6+N2000+X1555
75	CPC5077xFD	R6	350 MCM 274 in-lbs	#1/0 70 in-lbs	350 MCM 360 in-lbs	3 x #3/0 250 in-lbs	ACS550-PD-77A1-6+N2000+X1555
100	CPC5099xFD	R6		ACS550-PD-99A1-6+N2000+X1555			
125	CPC5125xFD	R6		300 MCM 275 in-lbs			ACS550-PD-125A1-6+N2000+X1555
150	CPC5144xFD	R6		ACS550-PD-144A1-6+N2000+X1555			

NOTE: "x" represents both NEMA 1 and NEMA 12.

TECHNICAL DATA

Cable Terminals (Frames R1-R6)

Frame Size	U1, V1, W1 U2, V2, W2 BRK±, UDC± Terminals						Earthing PE Terminal			
	Minimum Wire Size		Maximum Wire Size		Tightening Torque		Maximum Wire Size		Tightening Torque	
	mm ²	AWG	mm ²	AWG	N·m	lb·ft	mm ²	AWG	N·m	lb·ft
R1 ¹	0.75	18	10	8	1.4	1	10	8	1.4	1
R2 ¹	0.75	18	10	8	1.4	1	10	8	1.4	1
R3 ¹	2.5	14	25	3	2.5	1.8	16	6	1.8	1.3
R4 ¹	6	10	50	1/0	5.6	4	25	3	2	1.5
R5 ¹	6	10	70	2/0	15	11	70	2/0	15	11
R6	95	3/0	240	350 MCM	40	30	95	3/0	8	6

¹ Aluminum cable cannot be used with frame sizes R1...R6 because of its lower capacity.

Note: See the recommended cable sizes for different load currents in section Cable Sizing/Ratings.

Motor Connections

Motor Connection Specifications - R7/R8

Motor Connection Specifications				
Maximum Motor Cable Length	Frame Size	Maximum Motor Cable Length*		
		f _{sw} = 1 or 4 kHz		f _{sw} = 8 kHz or 12 kHz
		R7...R8	300 m	980 ft



WARNING! Using a motor cable longer than specified in the chart above may cause permanent damage to the drive.

Cooling - R7/R8

Cooling Specifications	
Method	Internal fan, flow direction from bottom to top.
Requirement	• R7/R8: Free space in front of enclosure: 152 mm (6 in).
	• R7/R8: Free space above enclosure: None required for cooling.
	• R7/R8: Free space at sides of enclosure: None required for cooling.
	• R7/R8: Also see "Additional Free Space Recommendations" on page 33.

Air Flow, 380...480 Volt Drives - R7/R8

The following table lists heat loss and air flow data for 380...480 Volt drives.

Drive		Heat Loss		Air Flow	
CPC-xx-	Frame Size	W	BTU/Hr	m ³ /h	ft ³ /min
-245A-4	R7	3850	13000	300	540
-316A-4	R8	5300	18000	700	1220
-368A-4	R8	6850	23000	700	1220
-414A-4	R8	7000	24000	700	1220
-486A-4	R8	7600	26000	700	1220
-526A-4	R8	7800	27000	700	1220
-602A-4	R8	8100	28000	700	1220
-645A-4	R8	9100	31000	700	1220

TECHNICAL DATA

Dimensions and Weights (Supplement to Aquavar CPC User's Manual)

Mounting Dimensions

NEMA 1 & 12, R1...R6 Mounting Dimensions

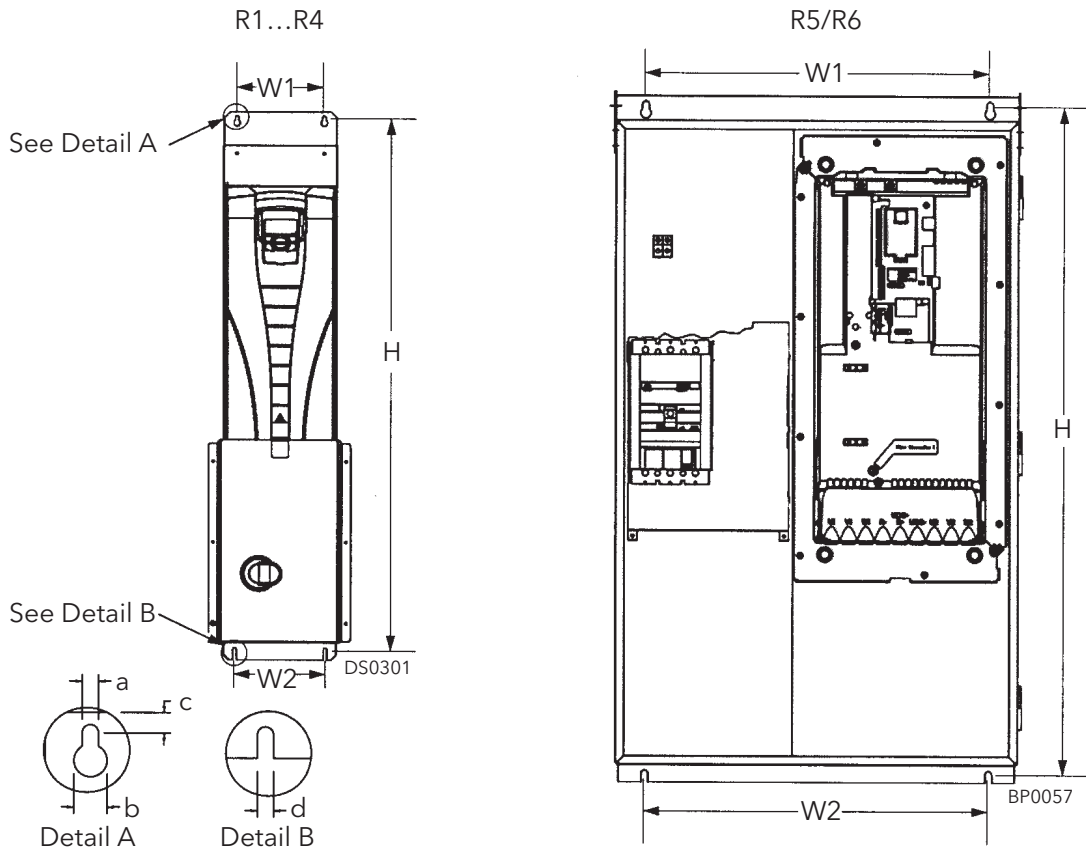

NEMA 1 and NEMA 12 - Mounting Dimensions for each Frame Size

Ref.	R1		R2		R3		R4		R5		R6	
	mm	in	mm	in	mm	in	mm	in	mm	in	mm	in
W1*	98	3.9	98	3.9	160	6.3	160	6.3	600	23.6	600	23.6
W2*	98	3.9	98	3.9	160	6.3	160	6.3	600	23.6	600	23.6
H*	712	28.0	812	32.0	983	38.7	1117	44.0	1175	46.3	1175	46.3
a	5.5	0.2	5.5	0.2	6.5	0.25	6.5	0.25	6.5	0.25	9.0	0.35
b	10.0	0.4	10.0	0.4	13.0	0.5	13.0	0.5	14.0	0.55	14.0	0.55
c	5.5	0.2	5.5	0.2	8.0	0.3	8.0	0.3	8.5	0.3	8.5	0.3
d	5.5	0.2	5.5	0.2	6.5	0.25	6.5	0.25	6.5	0.25	9.0	0.35
Mounting Hardware												
	M6	1/4	M6	1/4	M6	1/4	M6	1/4	M8	5/16	M8	5/16

* Measurements are center to center.

NOTE: -088A-2, -114A-2 and -097A-4 NEMA 1 & 12 units are R4 frame base drives in R5 enclosures. R5 enclosure information applies.

TECHNICAL DATA

NEMA 1 & 12, R7...R8 Mounting Dimensions

NEMA 1 and NEMA 12 - Dimensions for each Frame Size			
Ref.	R7 & R8		Top View
	mm	in	
W	806	31.7	
D	659	25.9	
a	675	26.6	
b	474.5	18.7	
c	61	2.4	
d	65.5	2.6	
Mounting Hardware			
	11 mm	13/32	

* Measurements are center to center.

Weights

The following table lists typical maximum weights for each frame size. Variations within each frame size (due to components associated with voltage/current ratings and options) are minor.

En- closure	Weight															
	R1		R2		R3		R4		R5		R6		R7		R8	
	kg	lb.	kg	lb.	kg	lb.	kg	lb.	kg	lb.	kg	lb.	kg	lb.	kg	lb.
NEMA 1	13	28	17	37	45	100	55	121	121	266	163	360	230	506	360	793
NEMA 12	15	33	19	42	47	103	57	125	123	271	166	375	250	551	380	837

NOTE: -088A-2, -114A-2 and -097A-4 NEMA 1 & 12 units are R4 frame base drives in R5 enclosures. R5 enclosure information applies.

TECHNICAL DATA

Outside Dimensions

Outside Dimensions

NEMA 1, R1...R4 Outside Dimensions

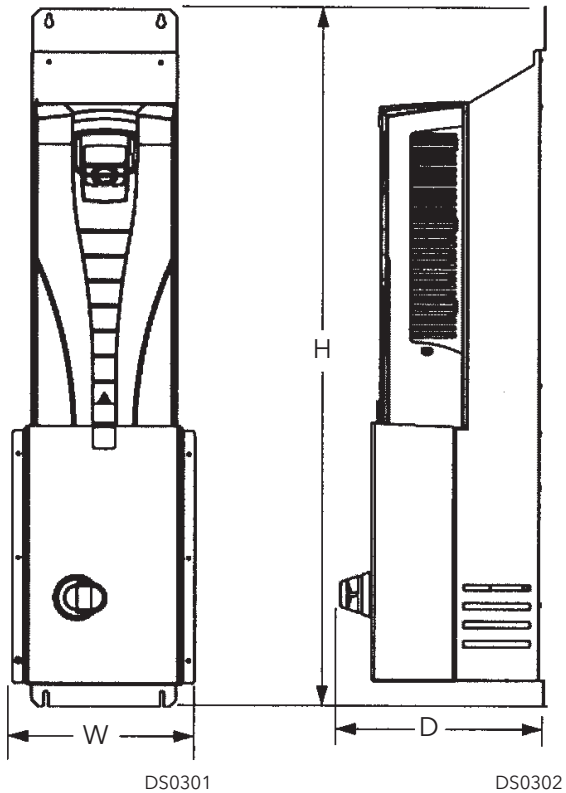

Input Disconnect, NEMA 1, R1...R4								
Dimensions Ref.	R1		R2		R3		R4	
	mm	in	mm	in	mm	in	mm	in
W	198	7.8	198	7.8	260	10.2	260	10.2
H	729	28.7	829	32.6	1013	39.9	1147	45.2
D	283	11.2	295	11.6	304	11.9	332	13.1

NOTE: -088A-2, -114A-2 and -097A-4 NEMA 1 & 12 units are R4 frame base drives in R5 enclosures. R5 enclosure information applies.

TECHNICAL DATA

NEMA 12, R1...R4 Outside Dimensions

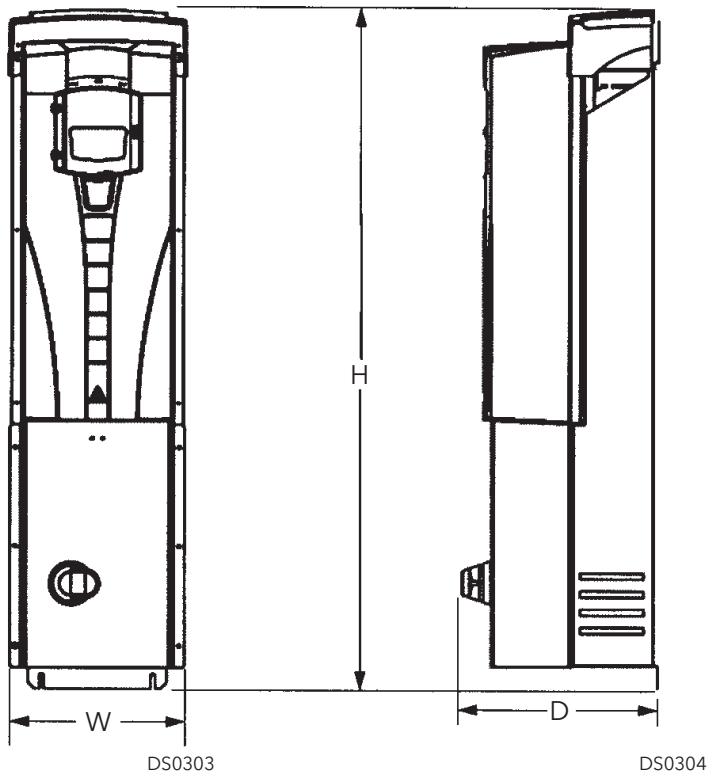

Input Disconnect, NEMA 12, R1...R4								
Dimensions Ref.	R1		R2		R3		R4	
	mm	in	mm	in	mm	in	mm	in
W	222	8.7	222	8.7	267	10.5	267	10.5
H	744	29.3	844	33.2	1030	40.6	1163	45.8
D	283	11.2	295	11.6	304	11.9	332	13.1

NOTE: -088A-2, -114A-2 and -097A-4 NEMA 1 & 12 units are R4 frame base drives in R5 enclosures. R5 enclosure information applies.

TECHNICAL DATA

NEMA 1, R5/R6 Outside Dimensions

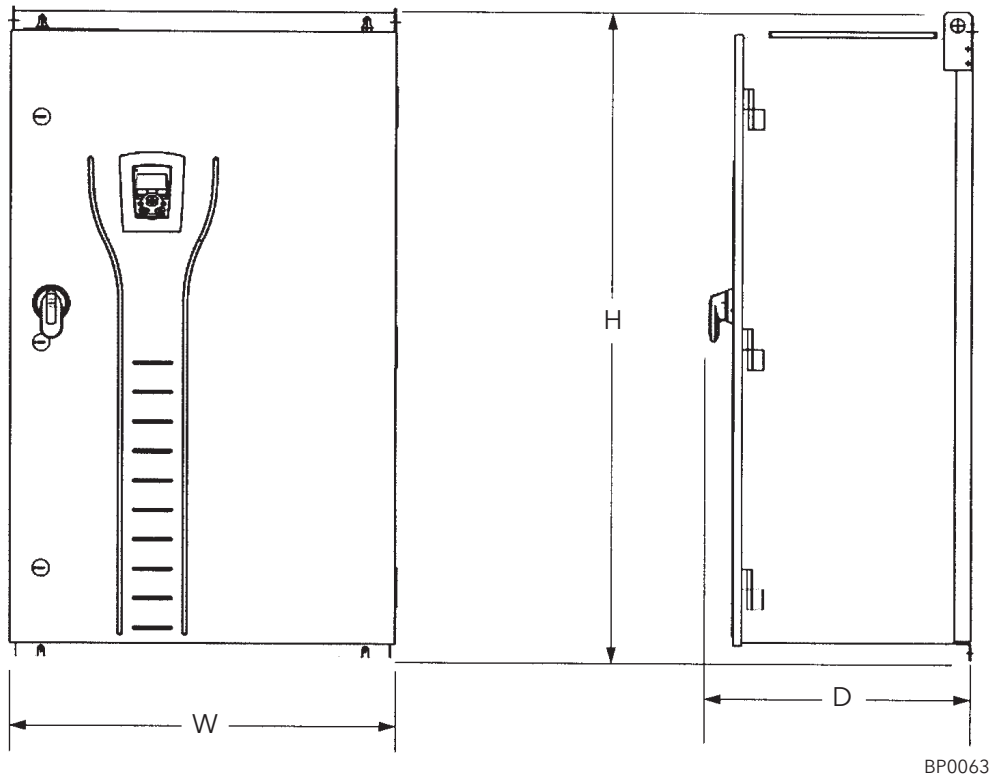

Input Disconnect, NEMA 1, R5/R6				
Dimensions Ref.	R5		R6	
	mm	in	mm	in
W	713	28.1	713	28.1
H	212	47.7	1212	47.7
D	484	19.1	484	19.1

NOTE: -088A-2, -114A-2 and -097A-4 NEMA 1 & 12 units are R4 frame base drives in R5 enclosures. R5 enclosure information applies.

TECHNICAL DATA

NEMA 12, R5/R6 Outside Dimensions

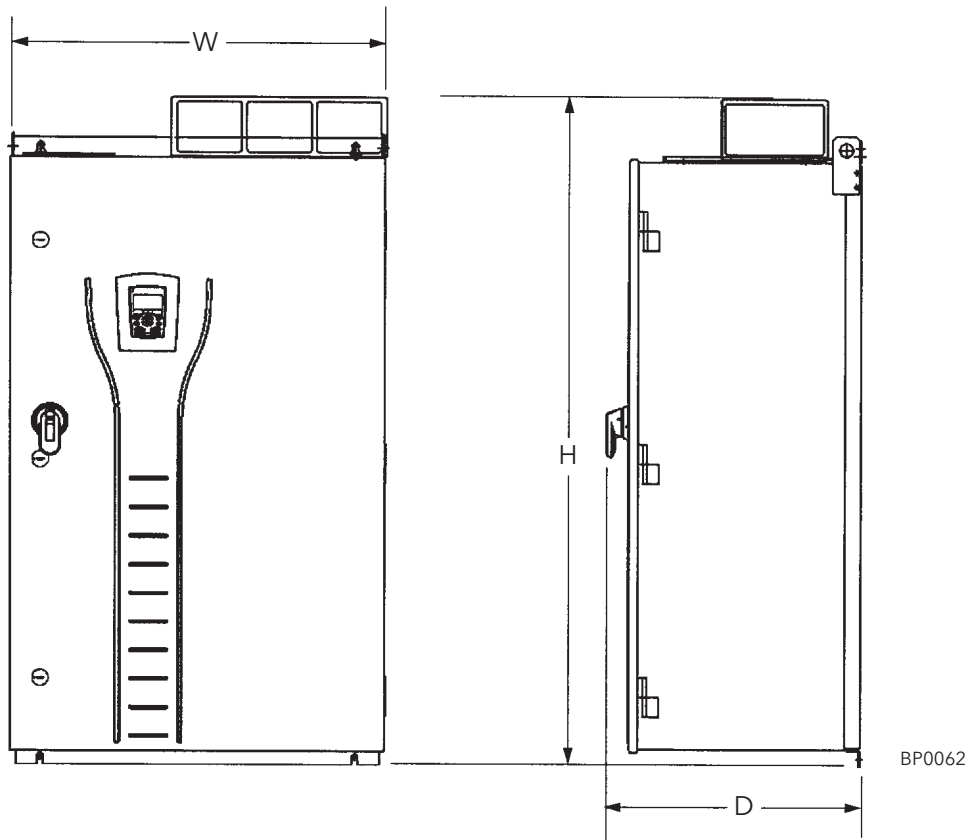

Input Disconnect, NEMA 12, R5/R6				
Dimensions Ref.	R5		R6	
	mm	in	mm	in
W	734	28.9	734	28.9
H	1371	54.0	1371	54.0
D	484	19.1	484	19.1

NOTE: -088A-2, -114A-2 and -097A-4 NEMA 1 & 12 units are R4 frame base drives in R5 enclosures. R5 enclosure information applies.

TECHNICAL DATA

NEMA 1 & 12, R7...R8 Outside Dimensions

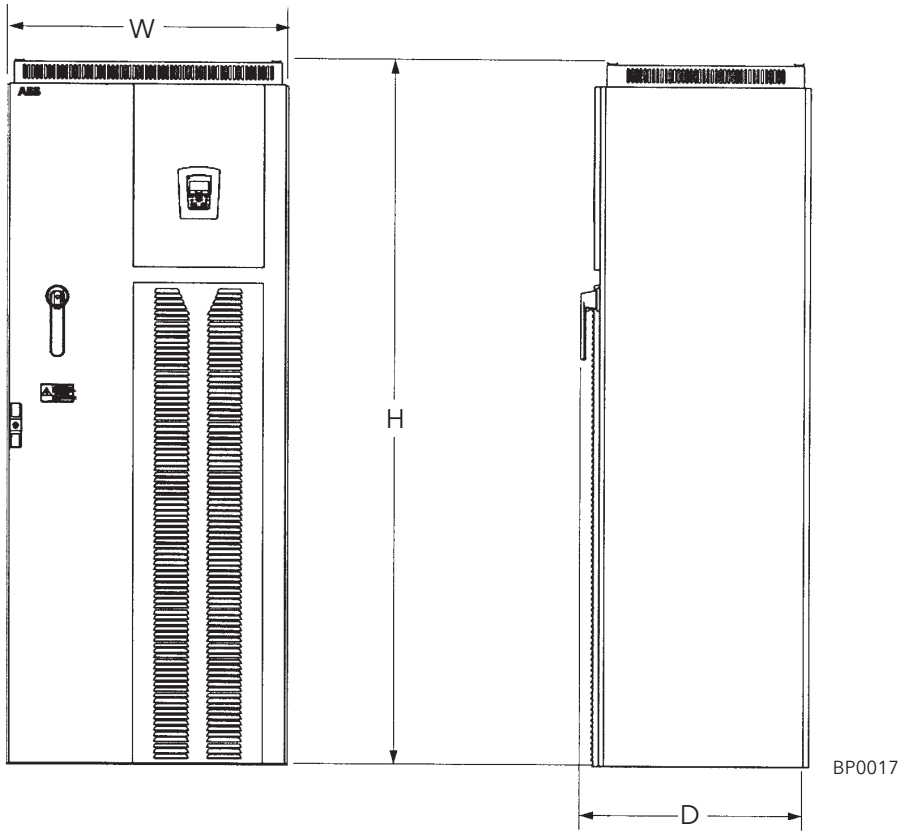

Outside Dimensions by Frame Size					
Enclosure	Ref.	R7		R8	
		mm	in	mm	in
NEMA 1	W	806	31.7	806	31.7
	H	2125	83.7	2125	83.7
	D	659	25.9	659	25.9
NEMA 12	W	806	31.7	806	31.7
	H	2377	93.6	2377	93.6
	D	659	25.9	659	25.9

Additional Free Space Recommendations

In addition to the free space requirements for cooling ("Cooling - R7/R8"), allow:

- 800 mm (31.5 in) in front of R7/R8 enclosures - room for the cabinet door to swing open.
- 305 mm (12 in) above R7/R8, IP54 / UL Type 12 enclosures - room for fan replacement.

TECHNICAL DATA

Applicable Standards

Drive compliance with the following standards is identified by the standards "marks" on the type code label.

Mark	Applicable Standards	
	UL 508C and C22.2 No. 14	UL Standard for Safety, Power Conversion Equipment, second edition and CSA Standard for Industrial Control Equipment
	UL 508A	UL Standard for Safety, Industrial Control Panels
	C22.2 No. 14	CSA Standard for Industrial Control Equipment

Compliance is valid with the following provisions:

- The motor and control cables are chosen as specified in this manual.
- The installation rules of this manual are followed.

The AQUAVAR is suitable for use on a circuit capable of delivering not more than 100,000 RMS symmetrical amperes, 600 V maximum.

For open type enclosures, that is units without the conduit box and/or cover for enclosures, that is units without the conduit box and/or cover for IP21/UL type 1 units or without the conduit plate and/or top cover for IP54 units, the unit must be mounted inside an enclosure per National Electrical Code and local electrical codes.

UL/CSA Markings



A UL mark is attached to ACS550 drives to verify that the drive follows the provisions of UL 508C.



A CSA mark is attached to ACS550-U1 type drives to verify that the drive follows the provisions of C22.2 NO. 14.

The ACS550 is suitable for use in a circuit capable of delivering not more than 100 kA RMS symmetrical amperes, 600 V maximum. The ampere rating is based on tests done according to UL 508.

Branch circuit protection must be provided in accordance with local codes.

The ACS550 has an electronic motor protection feature that complies with the requirements of UL 508C and, for ACS550-U1, C22.2 No. 14. When this feature is selected and properly adjusted, additional overload protection is not required unless more than one motor is connected to the drive or unless additional protection is required by applicable safety regulations. See parameters 3005 (MOT THERM PROT) and 3006 (MOT THERM RATE).

The drives are to be used in a controlled environment.



Note: For open type enclosures, i.e. drives without the conduit box and/or cover for IP21 / UL type 1 drives, or without the conduit plate and/or hood for IP54 / UL type 12 drives, the drive must be mounted inside an enclosure in accordance with National Electric Code and local electrical codes.

Brake choppers, when applied with appropriately sized brake resistors, will allow the drive to dissipate regenerative energy (normally associated with quickly decelerating a motor). Frame sizes R1 and R2 have a built-in brake chopper as standard equipment. For frame sizes R3...R6, contact your ABB representative for appropriate parts.



WARNING! Do not attempt to install or remove EM1, EM3, F1 or F2 screws while power is applied to the drive's input terminals.



WARNING! Do not control the motor with the disconnecting device (disconnecting means); instead, use the control panel start and stop keys  and , or commands via the I/O board of the drive. The maximum allowed number of charging cycles of the DC capacitors (i.e. power-ups by applying power) is five in ten minutes.

TECHNICAL DATA

CE Marking



A CE mark is attached to the drive to verify that the drive follows the provisions of the European Low Voltage and EMC Directives.

Note: The 600 V ACS550-U1 drives are not CE approved.

Compliance with the EMC Directive

The Directive defines the requirements for immunity and emissions of electrical equipment used within the European Union. The EMC product standard (IEC/EN 61800-3 [2004]) covers requirements stated for drives.

Compliance with IEC/EN 61800-3 (2004)

C-Tick Marking



The drive carries C-Tick marking.

C-Tick marking is required in Australia and New Zealand. A C-Tick mark is attached to the drive to verify compliance with the relevant standard (IEC 61800-3 (2004) – Adjustable speed electrical power drive systems – Part 3: EMC product standard including specific test methods), mandated by the Trans-Tasman Electromagnetic Compatibility Scheme.

The Trans-Tasman Electromagnetic Compatibility Scheme (EMCS) was introduced by the Australian Communication Authority (ACA) and the Radio Spectrum Management Group (RSM) of the New Zealand Ministry of Economic Development (NZMED) in November 2001. The aim of the scheme is to protect the radio frequency spectrum by introducing technical limits for emission from electrical/ electronic products.

Compliance with IEC/EN 61800-3 (2004)

INDEX

Refer to the Aquavar CPC User's Manual (IM167) index for topics not listed here.

	A			F
air flow		32	fan, drive module	
	C		maintenance interval	14
cable requirements			replacement procedure	14
input power		28	fan, enclosure	
capacitor			maintenance interval	14
change, maintenance interval		14	replacement procedure	14
connection points			filter, enclosure	
floor mounted enclosures		12	R5/R6 inlet, maintenance interval	14
wall mounted enclosures		11	R5/R6 inlet, maintenance procedure	16
model code		8	R7/R8, exhaust, maintenance interval	14
control panel			R7/R8, exhaust, maintenance procedure	18
maintenance interval, battery		14	R7/R8, inlet, maintenance interval	14
cooling		32	R7/R8, inlet, maintenance procedure	16
cover			free space	
remove		6	for access, R7/R8	39
current			for cooling	32
rating code		8	fuses	26
	D		208...240 volt drives	26
dimensions			380...480 volt drives	27
mounting, R1...R6		33	500...600 volt drives	28
mounting, R7...R8		34		G
outside, NEMA 12, R1...R4		36	grounding	
outside, NEMA 12, R5...R6		38	requirements	10
outside, NEMA 1, R1...R4		35		H
outside, NEMA 1, R5...R6		37	heat loss	232
outside, NEMA 1/NEMA 12, R7...R8		39	heatsink	
disconnect			maintenance interval	14
diagram		4		I
features, functions			input disconnect	
drive			see disconnect	
fan replacement		14	input power	
identification		8	cable/wire requirements	28
proper lifting		7	fuses	26
weight		34	installation	
	E		flow chart	6
enclosure protection class code		8	preparation	7
enclosure, NEMA 12				L
air filter maintenance		16	label	
fan replacement		15	type code	8
			location, mounting	9

INDEX

M		T	
maintenance		terminals	
drive module fan replacement	14	power, wire sizes	29
enclosure fan replacement	14	type code	8
intervals	14	V	
R5/R6 enclosure inlet filter	16	voltage	
R7/R8 enclosure exhaust filter	18	rating code	8
R7/R8 enclosure inlet filter	16	W	
manuals, listing	ii	warning	
motor		automatic start up	3
connection specifications	32	dangerous voltages	3
motor cable		listing	3
maximum length	32	parallel control connections	3
		qualified installer	3
N		weight	
NEMA 1		drive	34
code	8	wiring	
NEMA 12		connection diagrams, floor mounted	12
code	8	connection diagrams, wall mounted	11
		line input installation	13
R		overview	11
ratings	25	requirements	10
remove cover	6		
S			
safety	3		
specifications			
cooling	32		
motor connections	32		
standards	40		
C22.2 No. 14	40		
UL 508C	40		



CENTRIPRO LIMITED WARRANTY

This warranty applies to all Aquavar CPC controllers manufactured by Xylem, Inc.

Any part or parts found to be defective within the warranty period shall be replaced at no charge to the dealer during the warranty period. The warranty period shall exist for a period of twenty-four (24) months from date of installation or thirty (30) months from date of manufacture, whichever period is shorter.

A dealer who believes that a warranty claim exists must contact the authorized CentriPro distributor from whom the controller was purchased and furnish complete details regarding the claim. The distributor is authorized to adjust any warranty claims utilizing the CentriPro Customer Service Department.

The warranty excludes:

- (a) Labor, transportation and related costs incurred by the dealer;
- (b) Reinstallation costs of repaired equipment;
- (c) Reinstallation costs of replacement equipment;
- (d) Consequential damages of any kind; and,
- (e) Reimbursement for loss caused by interruption of service.

For purposes of this warranty, the following terms have these definitions:

- (1) "Distributor" means any individual, partnership, corporation, association, or other legal relationship that stands between CentriPro and the dealer in purchases, consignments or contracts for sale of the subject controllers.
- (2) "Dealer" means any individual, partnership, corporation, association, or other legal relationship which engages in the business of selling or leasing controllers to customers.
- (3) "Customer" means any entity who buys or leases the subject controllers from a dealer. The "customer" may mean an individual, partnership, corporation, limited liability company, association or other legal entity which may engage in any type of business.

THIS WARRANTY EXTENDS TO THE DEALER ONLY.



Xylem, Inc.
2881 East Bayard Street Ext., Suite A
Seneca Falls, NY 13148
Phone: (800) 453-6777
Fax: (888) 322-5877
www.centripro.com

CentriPro and Aquavar are trademarks of Xylem Inc. or one of its subsidiaries.
Goulds is a registered trademark of Goulds Pumps, Inc. and is used under license.
DUSTLOK® is a registered trademark of Fiberbond Corp.
Bussmann is a registered trademark of Cooper Industries Inc.
© 2012 Xylem Inc. IM250 Revision Number 3 March 2014