

Aquavar[®] Intelligent Pump Controller

Table of Contents

1 Introduction and Safety.....	3
1.1 Introduction.....	3
1.1.1 Qualified personnel.....	3
1.2 Safety.....	3
1.2.1 Safety message levels.....	4
1.3 User safety.....	4
1.3.1 Wash the skin and eyes.....	5
1.4 Protecting the environment.....	6
2 Transportation and Storage.....	7
2.1 Examine the delivery.....	7
2.1.1 Examine the package.....	7
2.1.2 Examine the unit.....	7
2.2 System lifting.....	7
2.3 Transportation guidelines.....	7
2.3.1 Precautions.....	7
2.4 Storage guidelines.....	8
3 Product Description.....	9
3.1 Product overview.....	9
3.2 Motor thermal protection.....	9
3.3 Dimensions.....	14
3.4 Frame size A description.....	16
3.5 Frame sizes B and C description.....	17
4 Installation.....	18
4.1 Installation site checklist.....	18
4.2 Frequency converter and motor pre-installation check list.....	18
5 Electrical Installation.....	19
5.1 Precautions.....	19
5.2 Basic electrical connection.....	21
5.3 Motor connection.....	22
5.3.1 Motor connection for A2 and A3.....	24
5.3.2 Motor connection for A4 and A5.....	25
5.3.3 Motor connection for B1 and B2.....	25
5.3.4 Motor connection for C1 and C2.....	26
5.3.5 AC mains connection.....	26
5.3.6 Control wiring.....	27
5.3.7 Control wiring access.....	27
5.3.8 Control terminal types.....	28
5.4 Wiring to control terminals.....	31
5.4.1 Unplug terminal connectors.....	31
5.4.2 Control terminal connections.....	31
5.4.3 Control terminal functions.....	33
5.4.4 Analog input 53.....	33
5.4.5 Jumper terminals 12 and 18.....	33
5.4.6 Using screened control cables.....	34
5.4.7 Serial communication.....	35
5.5 Common terminal wiring configurations.....	35

5.6 Local control panel.....	45
6 Mechanical Installation.....	53
6.1 Installation requirements.....	53
7 Operation.....	57
7.1 Pre-start procedure.....	57
7.2 Pre-startup inspections.....	57
7.3 Apply power.....	58
7.4 Discharge time.....	58
7.5 Frequency converter programming.....	59
7.5.1 Programming the controller.....	59
7.5.2 Setup and commissioning.....	64
7.5.3 Pump protection setup.....	80
7.5.4 Digital input setup.....	87
7.5.5 Relay and Analog Output Setup.....	90
7.5.6 Communication Setup.....	94
7.5.7 Automatic motor adaptation.....	95
7.6 Basic operational programming.....	96
7.7 Induction motor setup.....	97
7.8 PM motor setup.....	97
7.9 Check motor rotation.....	99
7.10 Local-control test.....	99
7.11 System start-up.....	100
7.12 Acoustic noise or vibration.....	100
8 Warnings and alarms.....	101
8.1 System monitoring.....	101
8.2 Warning and alarm types.....	101
8.3 Warning and alarm displays.....	102
8.4 Warnings and alarms.....	110
9 Troubleshooting.....	119
9.1 Start up and operation troubleshooting.....	119
10 Technical Specification.....	122
10.1 Power-dependent specifications.....	122
10.2 General technical data.....	128
10.3 Fuses and circuit breakers.....	134
10.4 Wire sizing charts.....	141
10.5 Parameter list.....	145
11 Product warranty.....	147

1 Introduction and Safety

1.1 Introduction

Purpose of this manual

The purpose of this manual is to provide necessary information for:

- Installation
- Operation
- Maintenance



CAUTION:

Read this manual carefully before installing and using the product. Improper use of the product can cause personal injury and damage to property, and may void the warranty.

NOTICE:

Save this manual for future reference, and keep it readily available at the location of the unit.

1.1.1 Qualified personnel



WARNING:

This product is intended to be operated by qualified personnel only.

- Correct and reliable transport, storage, installation, operation, and maintenance are required for the trouble-free and safe operation of the frequency converter. Only qualified personnel are allowed to install or operate this equipment.
- Qualified personnel are defined as trained staff, who are authorized to install, commission, and maintain equipment, systems, and circuits in accordance with pertinent laws and regulations. Also, the personnel must be familiar with the instructions and safety measures that are described in this document.

1.2 Safety



WARNING:

- The operator must be aware of safety precautions to prevent physical injury.
 - Operating, installing, or maintaining the unit in any way that is not covered in this manual could cause death, serious personal injury, or damage to the equipment. This includes any modification to the equipment or use of parts not provided by Xylem. If there is a question regarding the intended use of the equipment, please contact a Xylem representative before proceeding.
 - Do not change the service application without the approval of an authorized Xylem representative.
-



CAUTION:

You must observe the instructions contained in this manual. Failure to do so could result in physical injury, damage, or delays.





1.2.1 Safety message levels

About safety messages

It is extremely important that you read, understand, and follow the safety messages and regulations carefully before handling the product. They are published to help prevent these hazards:

- Personal accidents and health problems
- Damage to the product
- Product malfunction

Definitions

Safety message level	Indication
 DANGER:	A hazardous situation which, if not avoided, will result in death or serious injury
 WARNING:	A hazardous situation which, if not avoided, could result in death or serious injury
 CAUTION:	A hazardous situation which, if not avoided, could result in minor or moderate injury
 Electrical Hazard:	The possibility of electrical risks if instructions are not followed in a proper manner
NOTICE:	<ul style="list-style-type: none"> • A potential situation which, if not avoided, could result in undesirable conditions • A practice not related to personal injury

1.3 User safety

General safety rules

These safety rules apply:

- Always keep the work area clean.
- Pay attention to the risks presented by gas and vapors in the work area.
- Avoid all electrical dangers. Pay attention to the risks of electric shock or arc flash hazards.
- Always bear in mind the risk of drowning, electrical accidents, and burn injuries.

Safety equipment

Use safety equipment according to the company regulations. Use this safety equipment within the work area:

- Hard hat
- Safety goggles, preferably with side shields
- Protective shoes
- Protective gloves
- Gas mask
- Hearing protection

- First-aid kit
- Safety devices

NOTICE:

Never operate a unit unless safety devices are installed. Also see specific information about safety devices in other chapters of this manual.

Electrical connections

Electrical connections must be made by certified electricians in compliance with all international, national, state, and local regulations. For more information about requirements, see sections dealing specifically with electrical connections.

Precautions before work

Observe these safety precautions before you work with the product or are in connection with the product:

- Provide a suitable barrier around the work area, for example, a guard rail.
- Make sure that all safety guards are in place and secure.
- Make sure that you have a clear path of retreat.
- Make sure that the product cannot roll or fall over and injure people or damage property.
- Make sure that the lifting equipment is in good condition.
- Use a lifting harness, a safety line, and a breathing device as required.
- Allow all system and pump components to cool before you handle them.
- Make sure that the product has been thoroughly cleaned.
- Disconnect and lock out power before you service the pump.
- Check the explosion risk before you weld or use electric hand tools.

Precautions during work

Observe these safety precautions when you work with the product or are in connection with the product:

- Never work alone.
- Always wear protective clothing and hand protection.
- Stay clear of suspended loads.
- Always lift the product by its lifting device.
- Beware of the risk of a sudden start if the product is used with an automatic level control.
- Beware of the starting jerk, which can be powerful.
- Rinse the components in water after you disassemble the pump.
- Do not exceed the maximum working pressure of the pump.
- Do not open any vent or drain valve or remove any plugs while the system is pressurized. Make sure that the pump is isolated from the system and that pressure is relieved before you disassemble the pump, remove plugs, or disconnect piping.
- Never operate a pump without a properly installed coupling guard.

1.3.1 Wash the skin and eyes

Follow these procedures for chemicals or hazardous fluids that have come into contact with your eyes or your skin:

Condition	Action
Chemicals or hazardous fluids in eyes	<ol style="list-style-type: none"> 1. Hold your eyelids apart forcibly with your fingers. 2. Rinse the eyes with eyewash or running water for at least 15 minutes. 3. Seek medical attention.

Condition	Action
Chemicals or hazardous fluids on skin	<ol style="list-style-type: none"> 1. Remove contaminated clothing. 2. Wash the skin with soap and water for at least 1 minute. 3. Seek medical attention, if necessary.

1.4 Protecting the environment

Emissions and waste disposal

Observe the local regulations and codes regarding:

- Reporting of emissions to the appropriate authorities
- Sorting, recycling and disposal of solid or liquid waste
- Clean-up of spills

Exceptional sites



CAUTION: Radiation Hazard

Do NOT send the product to Xylem if it has been exposed to nuclear radiation, unless Xylem has been informed and appropriate actions have been agreed upon.

Recycling guidelines

Always follow local laws and regulations regarding recycling.

Waste and emissions guidelines

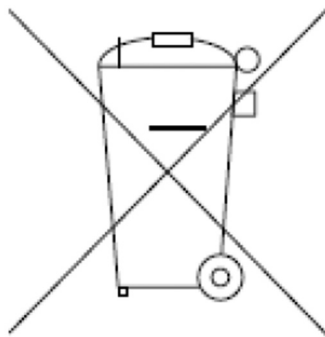

Do not dispose of equipment containing electrical components together with domestic waste.

Collect it separately in accordance with local and currently valid legislation.

2 Transportation and Storage

2.1 Examine the delivery

2.1.1 Examine the package

1. Examine the package for damaged or missing items upon delivery.
2. Record any damaged or missing items on the receipt and freight bill.
3. If anything is out of order, then file a claim with the shipping company.
If the product has been picked up at a distributor, make a claim directly to the distributor.

2.1.2 Examine the unit

1. Remove packing materials from the product.
Dispose of all packing materials in accordance with local regulations.
2. To determine whether any parts have been damaged or are missing, examine the product.
3. If applicable, unfasten the product by removing any screws, bolts, or straps.
Use care around nails and straps.
4. If there is any issue, then contact a sales representative.

2.2 System lifting



WARNING:

Assembled units and their components are heavy. Failure to properly lift and support this equipment can result in serious physical injury and/or equipment damage. Lift equipment only at the specifically identified lifting points. Lifting devices such as eyebolts, slings, and spreaders must be rated, selected, and used for the entire load being lifted.



WARNING: Crush Hazard

1) Always lift the unit by its designated lifting points. 2) Use suitable lifting equipment and ensure that the product is properly harnessed. 3) Wear personal protective equipment. 4) Stay clear of cables and suspended loads.

2.3 Transportation guidelines

2.3.1 Precautions



DANGER: Crush Hazard

Moving parts can entangle or crush. Always disconnect and lock out power before servicing to prevent unexpected startup. Failure to do so could result in death or serious injury.

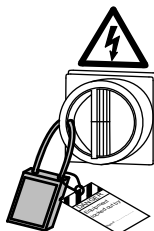

2.4 Storage guidelines

Storage location

The product must be stored in a covered and dry location free from heat, dirt, and vibrations.

NOTICE:

Protect the product against humidity, heat sources, and mechanical damage.

NOTICE:

Do not place heavy weights on the packed product.

3 Product Description

3.1 Product overview



WARNING:

This product can expose you to chemicals including Lead, which is known to the State of California to cause cancer and birth defects or other reproductive harm. For more information go to: www.P65Warnings.ca.gov.

A frequency converter is an electronic motor controller that converts AC mains input into DC and then into a variable voltage, variable frequency output waveform. The following is a list of functions of the frequency converter:

- Regulates the frequency and voltage to control the motor speed or torque.
- Varies the speed of the motor in response to system feedback, such as changing temperature or pressure for controlling fan, compressor, or pump motors.
- Regulates the motor by responding to remote commands from external controls.
- Monitors the system and motor status.
- Issues warnings or alarms for fault conditions.
- Starts and stops the motor.
- Optimizes energy efficiency.

Operation and monitoring functions are available as status indications to an outside control system or serial communication network.

Approvals and certifications



The unit complies with UL508C thermal memory retention requirements.

3.2 Motor thermal protection

Motor Thermal Protection can be implemented using various techniques: PTC sensor in motor windings, mechanical thermal switch, (Klixon type) or Electronic Thermal Relay (ETR).

Protection against motor overheating comes from [1-90] **Motor Thermal Protection**. If the ETR function is desired, set [1-90] **Motor Thermal Protection** to data value [4] ETR trip (default value) or data value [3] ETR warning.

NOTICE: The ETR function is initialized at 1.16 x rated motor current and rated motor frequency. The ETR function provides class 20 motor overload protection in accordance with the NEC.

Motor Thermal Protection prevents the motor from overheating. The ETR function is an electronic feature that simulates a bimetal relay that is based on internal measurements. The characteristic is shown in the following figure.

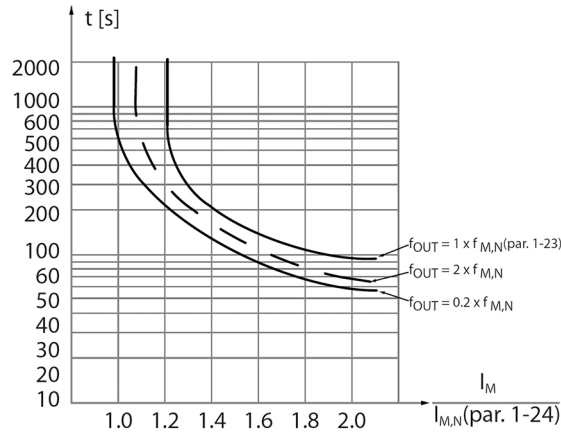

Figure 1: The characteristics of ETR function

The X-axis shows the ratio between I_{motor} actual and I_{motor} nominal. The Y-axis shows the time in seconds before the ETR cuts off and trips the frequency converter. The curves show the characteristic nominal speed, at twice the nominal speed and at 20% of the nominal speed. The curve shows that at lower speed the ETR cuts off at lower heat due to less cooling of the motor. In that way, the motor is protected from overheating even at low speed. The ETR function calculates the motor temperature that is based on actual current and speed. The calculated temperature is visible as a readout parameter in [16-18] **Motor Thermal** in the frequency converter.

Motor Thermal Protection can also be achieved using an external thermistor. Set [1-90] **Motor Thermal Protection** to data value [2] Thermistor trip or data value [1] Thermistor warning. Set [1-93] **Thermistor Source** to the input to which the thermistor is connected. Refer to the examples below for wiring details.

The thermistor cut-out value is $>3k\Omega$. Integrate a thermistor (PTC sensor) in the motor for winding protection.

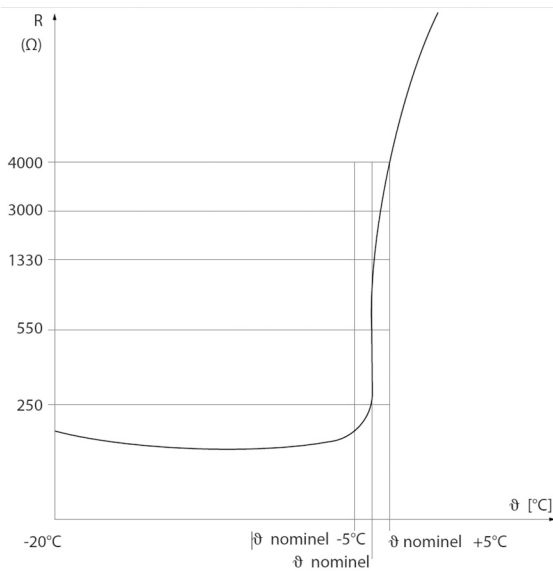

Figure 2: The characteristics of Thermistor resistant

The following examples show various ways to connect the PTC/Thermistor to the drive.

- Using a digital input and the 24 V as a power supply.
 - Parameter set-up:
 - Set [1-90] **Motor Thermal Protection** to Thermistor Trip [2]
 - Set [1-93] **Thermistor Source** to Digital Input 19 [4]

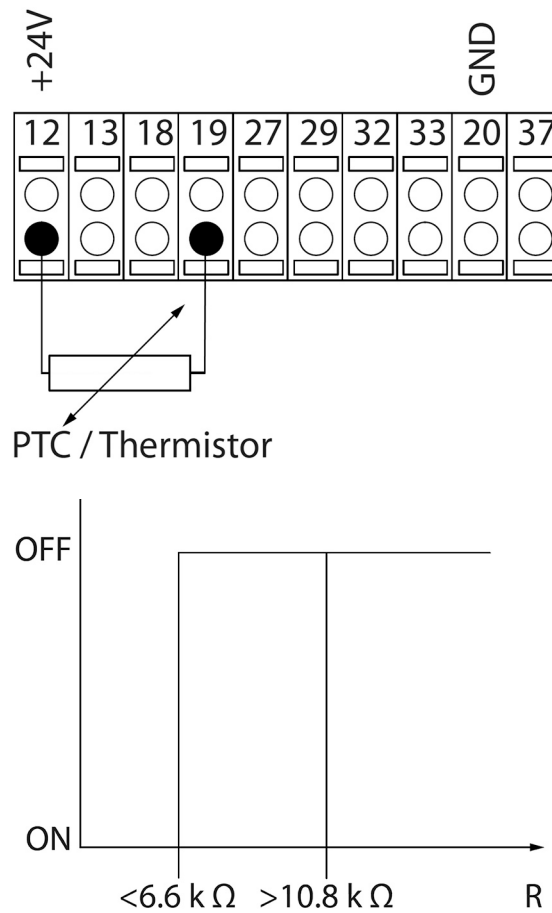
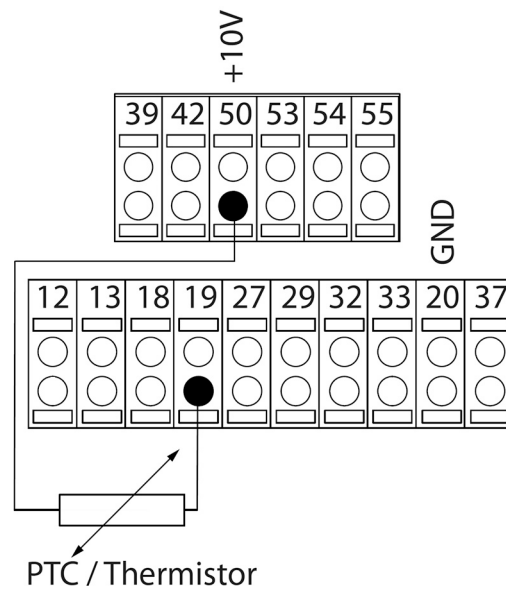

Figure 3: ON/OFF with a digital input and the 24 V as a power supply

- Using a digital input and the 10 V as a power supply.
 - Parameter set-up:
 - Set [1-90] **Motor Thermal Protection** to Thermistor Trip [2]
 - Set [1-93] **Thermistor Source** to Digital Input 19 [4]



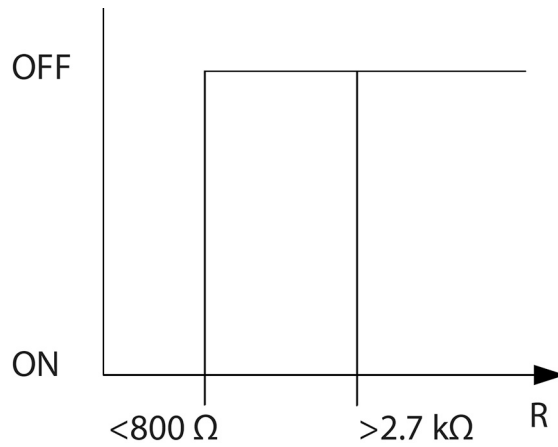
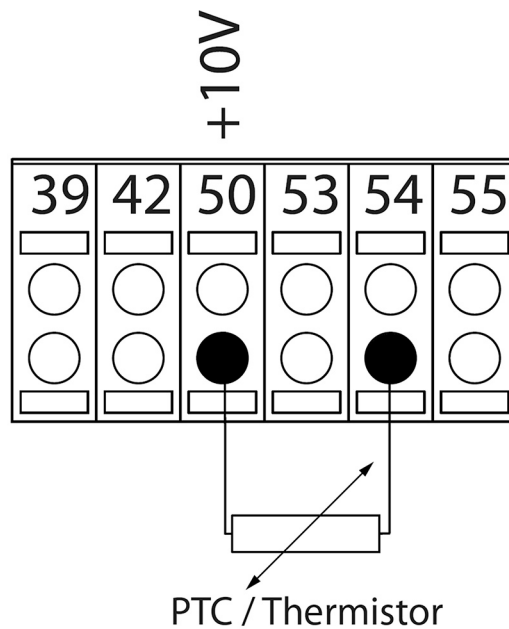

Figure 4: ON/OFF with a digital input and the 10 V as a power supply

- Using an analog input and 10 V as a power supply
 - Parameter set-up:
 - Set [1-90] **Motor Thermal Protection** to Thermistor Trip [2]
 - Set [1-93] **Thermistor Source** to Analog Input 54 [2]. Do not use Analog Input 54 as any other feedback or reference source. Be sure to configure the analog input configuration switches properly.



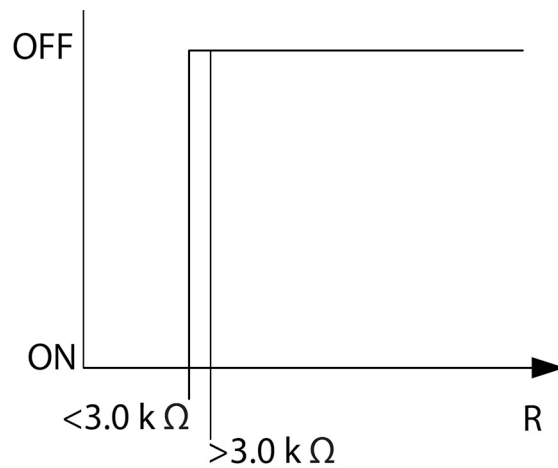

Figure 5: ON/OFF with an analog input and 10 V as a power supply

NOTE: Check that the chosen supply voltage follows the specifications of the thermistor element.

Summary

Input Digital/analog	Supply Voltage V Cut-out Values	Threshold Cut-out Values
Digital	24	< 6.6kΩ – > 10.8kΩ
Digital	10	< 800kΩ – > 2.7kΩ
Analog	10	< 3.0kΩ – > 3.0kΩ

With the Torque limit feature, the motor is protected from being overloaded independent of the speed. With the ETR, the motor is protected from being overheated and there is no need for any further motor protection. That means when the motor is heated up the ETR timer controls how long the motor can be operated at the high temperature before it is stopped to prevent overheating. If the motor is overloaded without reaching the temperature where the ETR turns off the motor, the torque limit protects the motor from being overloaded.

The ETR function is activated in [1-90] **Motor Thermal Protection** and is controlled in [4-16] **Torque Limit Motor Mode**. The time before the torque limit warning trips the drive is set in [14-25] **Trip Delay at Torque Limit**.

3.3 Dimensions

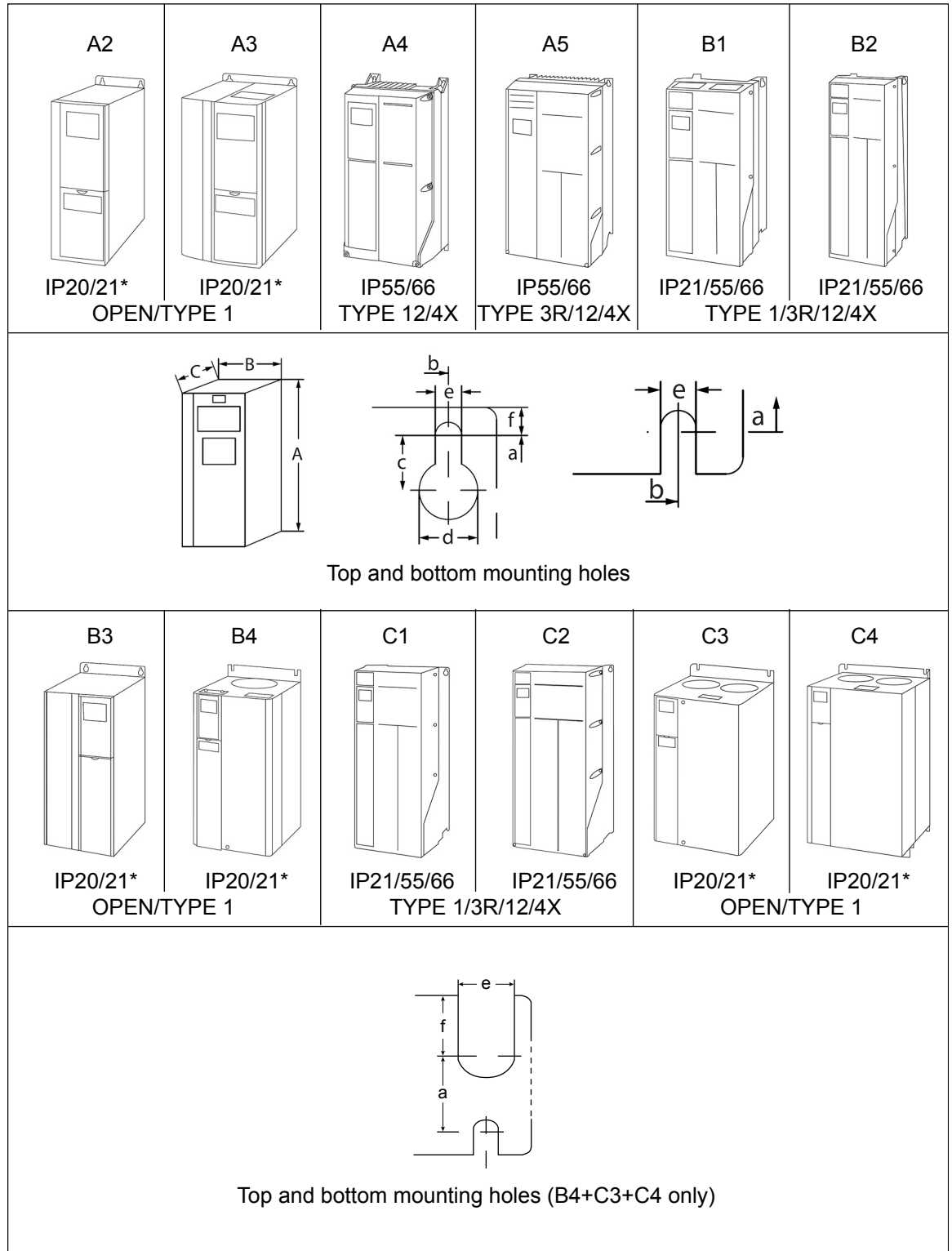

Mechanical Dimensions														
Frame Size (HP):	A2		A3		A4	A5	B1	B2	B3	B4	C1	C2	C3	C4
208-230 V	1.5-3		5		1.5-3	1.5-5	7.5-15	20	7.5-15	20-25	25-40	50-60	30-40	50-60
380-460 V	1.5-5		7.5-10		1.5-5	1.5-10	15-25	30-40	15-25	30-50	50-75	100-125	60-75	100-125
575 V			1.5-10			1.5-10	15-25	15-40	15-25	30-50	50-75	50-125	60-75	100-125
Single phase														
200-240	n/a		1.5	n/a	n/a	1.5	2 - 7.5	10	n/a	n/a	20	30	n/a	n/a
380-480	n/a		n/a		n/a	n/a	10	15	n/a	n/a	25	50	n/a	n/a
Enclosure rating														
IP Rating	IP20	IP21	IP20	IP21	IP55 IP66	IP55 IP66	IP55 IP66	IP55 IP66	IP20	IP20	IP55 IP66	IP55 IP66	IP20	IP20
UL Type	OPEN	1	OPEN	1	12 4X	3R 12 4X	3R 12 4X	3R 12 4X	OPEN	OPEN	3R 12 4X	3R 12 4X	OPEN	OPEN
Height in (mm)														
Enclosure	9.69 (246)	14.65 (372)	9.69 (246)	14.65 (372)	15.35 (390)	TYPE 12	18.90 (480)	25.59 (650)	13.78 (350)	18.11 (460)	26.77 (680)	30.31 (770)	19.29 (490)	23.62 (600)
with decoupling plate	14.72 (374)	-	14.72 (374)	-	-	IP66	-	-	16.5 (419)	23.43 (595)	-	-	24.8 (630)	31.5 (800)
Backplate	10.55 (268)	14.76 (375)	10.55 (268)	14.76 (375)	15.35 (390)	TYPE 4X	18.90 (480)	25.59 (650)	15.71 (399)	20.47 (520)	26.77 (680)	30.31 (770)	21.65 (550)	25.98 (660)
Distance between mounting holes	10.12 (257)	13.78 (350)	10.12 (257)	13.78 (350)	15.79 (401)	15.83 (402)	17.87 (454)	24.57 (624)	14.96 (380)	19.49 (495)	25.51 (648)	29.09 (739)	20.51 (521)	24.84 (631)
Width in (mm)														
Enclosure	3.54 (90)	3.54 (90)	5.12 (130)	5.12 (130)	7.87 (200)	9.53 (242)	9.53 (242)	9.53 (242)	6.50 (165)	9.09 (231)	12.13 (308)	14.57 (370)	12.13 (308)	14.57 (370)
Backplate	3.54 (90)	3.54 (90)	5.12 (130)	5.12 (130)	7.87 (200)	9.53 (242)	9.53 (242)	9.53 (242)	6.50 (165)	9.09 (231)	12.13 (308)	14.57 (370)	12.13 (308)	14.57 (370)
Distance between mounting holes	2.76 (70)	2.76 (70)	4.33 (110)	4.33 (110)	6.73 (171)	8.46 (215)	8.27 (210)	8.27 (210)	5.51 (140)	7.87 (200)	10.71 (272)	13.15 (334)	10.63 (270)	12.99 (330)
Depth in (mm)														
Without A/B Option Card*	8.07 (205)	8.07 (205)	8.07 (205)	8.07 (205)	6.89 (175)	7.87 (200)	10.24 (260)	10.24 (260)	9.76 (248)	9.53 (242)	12.20 (310)	13.19 (335)	13.11 (333)	13.11 (333)
With A/B Option Card*	8.66 (220)	8.66 (220)	8.66 (220)	8.66 (220)	6.89 (175)	7.87 (200)	10.24 (260)	10.24 (260)	10.31 (262)	9.53 (242)	12.20 (310)	13.19 (335)	13.11 (333)	13.11 (333)
Screw holes inches (mm)														
Screw hole c	0.31 (8)	0.31 (8)	0.31 (8)	0.31 (8)	0.32 (8.2)	0.32 (8.2)	0.47 (12)	0.47 (12)	0.31 (8)	-	0.47 (12)	0.47 (12)	-	-
Screw hole d	0.43 (11)	0.43 (11)	0.43 (11)	0.43 (11)	0.47 (12)	0.47 (12)	0.75 (19)	0.75 (19)	0.47 (12)	-	0.75 (19)	0.75 (19)	-	-
Screw hole e	0.22 (5.5)	0.22 (5.5)	0.22 (5.5)	0.22 (5.5)	0.26 (6.5)	0.26 (6.5)	0.35 (9)	0.35 (9)	0.27 (6.8)	0.33 (8.5)	0.35 (9)	0.35 (9)	0.33 (8.5)	0.33 (8.5)

Mechanical Dimensions														
Frame Size (HP):	A2		A3		A4	A5	B1	B2	B3	B4	C1	C2	C3	C4
Screw hole f	0.35 (9)	0.35 (9)	0.35 (9)	0.35 (9)	0.24 (6)	0.35 (9)	0.35 (9)	0.35 (9)	0.31 (7.9)	0.59 (15)	0.39 (9.8)	0.39 (9.8)	0.67 (17)	0.67 (17)
Max. weight – lb (kg)	11 (5)	12 (5.5)	15 (6.8)	16 (7.3)	22 (10)	31 (14.1)	51 (23.1)	60 (27.2)	27 (12.2)	52 (23.6)	100 (45.4)	144 (65.3)	78 (35.4)	111 (50.4)

3.4 Frame size A description

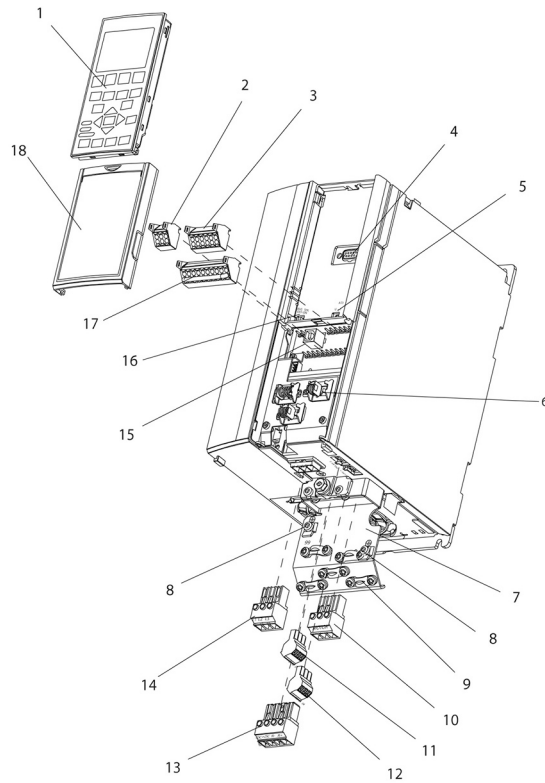

Figure 6: Exploded view of Frame Size A

1	LCP	10	Motor output terminals 96 (U), 98 (W)
2	RS-485 serial bus connector (+68, 69)	11	Relay 2 (01, 02, 03)
3	Analog I/O connector	12	Relay 1 (04, 05, 06)
4	LCP input plug	13	Brake (-81, +82) and load sharing (-88, +89) terminals
5	Analog switches (A53), (A54)	14	Mains input terminals 91 (L1), 92 (L2), 93 (L3)
6	Cable strain relief/PE ground	15	USB connector
7	Decoupling plate	16	Serial bus terminal switch
8	Grounding clamp (PE)	17	Digital I/O and 24 V power supply
9	Shielded cable grounding clamp and strain relief	18	Control cable cover plate

3.5 Frame sizes B and C description

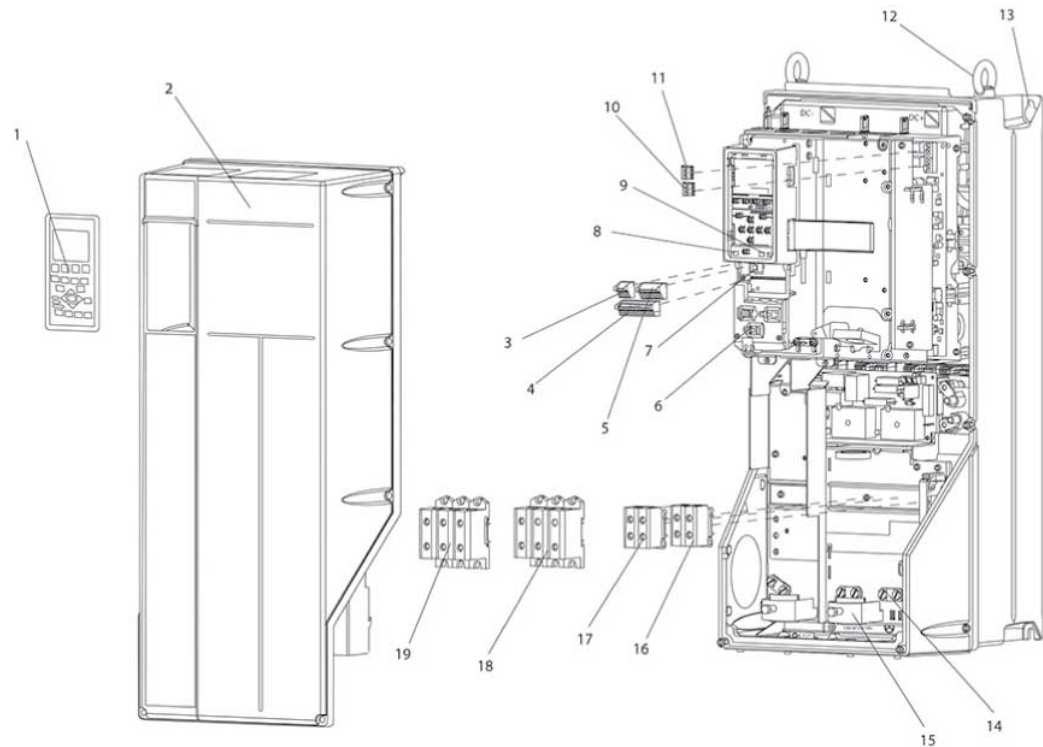

Figure 7: Exploded view of Frame Sizes B and C, IP55, IP66 UL Type 3R, 12 and 4X

1	LCP	11	Relay 2 (04, 05, 06)
2	Cover	12	Lifting ring
3	RS-485 serial bus connector	13	Mounting slot
4	Digital I/O and 24 V power supply	14	Grounding clamp (PE)
5	Analog I/O connector	15	Cable strain relief / PE ground
6	Cable strain relief/PE ground	16	Brake terminal (-81, +82)
7	USB connector	17	Load sharing terminal (DC bus) (-88, +89)
8	Serial bus terminal switch	18	Motor output terminals 96 (U), 98 (W)
9	Analog switches (A53), (A54)	19	Mains input terminals 91 (L1), 92 (L2), 93 (L3)
10	Relay 1 (01, 02, 03)		

4 Installation

4.1 Installation site checklist

- The frequency converter relies on the ambient air for cooling. Observe the limitations on ambient air temperature for optimal operation.
- Ensure that the installation location has sufficient support strength to mount the frequency converter.
- Keep the manual, drawings, and diagrams accessible for detailed installation and operation instructions. It is important that the manual is available for equipment operators.
- Locate equipment as near to the motor as possible. Keep motor cables as short as possible. Check the motor characteristics for actual tolerances.
 - For installations with motor leads longer than 50 feet, use the output filter option to protect the motor.
- Ensure that the ingress protection rating of the frequency converter is suitable for the installation environment. IP55 (Type 3R/12) or IP66 (Type 4X) enclosures may be necessary.



CAUTION:

Ingress protection. IP54, IP55 (Type 3R/12) and IP66 (Type 4X) ratings can only be guaranteed if the unit is properly closed.

- Ensure all cable glands and unused holes for glands are properly sealed.
- Ensure that the unit cover is properly closed.

Device damage through contamination. Do not leave the frequency converter uncovered.

4.2 Frequency converter and motor pre-installation check list

- Compare the model number of the unit on the nameplate to what was ordered to verify the proper equipment.
- Ensure each of the following are rated for same voltage:
 - Mains (power)
 - Frequency converter
 - Motor
- Ensure that the frequency converter output current rating is equal to or greater than motor service factor current for peak motor performance.
 - Motor size and frequency converter power must match for proper overload protection.
 - If frequency converter rating is less than motor, full motor output cannot be achieved.

5 Electrical Installation

5.1 Precautions



Electrical Hazard:

- Branch circuit protection required. Provide branch circuit protection in accordance with the National Electrical Code.
- Motor control equipment and electronic controls are connected to hazardous line voltages. Extreme care should be taken to protect against electrical hazard.
- Proper protective grounding of the equipment must be established. Ground currents are higher than 3 mA.
- A dedicated ground wire is required.



WARNING:

- **EQUIPMENT HAZARD.** Rotating shafts and electrical equipment can be hazardous. All electrical work must conform to national and local electrical codes. Installation, start-up, and maintenance must be performed by trained and qualified personnel. Wear safety glasses whenever working on electric control or rotating equipment. Failure to follow these guidelines could result in death or serious injury.
- **FIRE HAZARD.** Consult the Brake Design Guide IM257 for details on proper installation of a brake resistor.

NOTICE:

WIRING ISOLATION. Run input power, motor wiring and control wiring in three separate metallic conduits or use separated shielded cable for high frequency noise isolation. Failure to isolate power, motor and control wiring could result in less than optimum frequency converter and associated equipment performance.

For your safety comply with the following requirements:

- Electronic control equipment is connected to hazardous mains voltage. Extreme care should be taken to protect against electrical hazards when applying power to the unit.
- Run motor cable from multiple frequency converters separately. Induced voltage can charge equipment capacitors even with the equipment turned off and locked.

Overload and equipment protection:

- An electronically activated function within the frequency converter provides overload protection in the motor. The overload calculates the level of increase to activate timing for the trip (controller output stop) function. The higher the current draw, the quicker the trip response. The overload provides Class 20 motor protection. See Warnings and alarms section for details on the trip function.
- All frequency converters must be provided with short-circuit and over-current protection. Input fusing is required to provide this protection. If not factory supplied, fuses must be provided by the installer as part of installations. See Fuse specifications section for details.

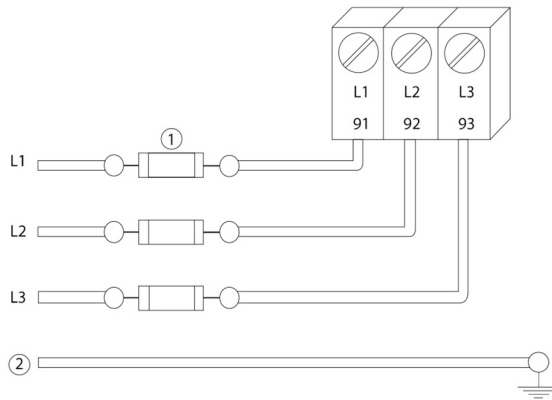

Figure 8: Frequency converter fuses

Item	Description
1	Fuses
2	Ground

Wire type and ratings:

- All wiring must comply with local and national regulations regarding cross section and ambient temperature requirements.
- It is recommended the all power connections be made with a minimum 75°C rated copper wire.
- See Power-dependent specifications section for recommended wire sizes.

Earth (grounding) requirements



WARNING:

For operator safety, it is important to ground the frequency converter properly in accordance with national and local electrical codes as well as instructions contained within this document. Ground currents are higher than 3.5 mA. Failure to ground the frequency converter properly could result in death or serious injury.

NOTICE:

It is the responsibility of the user or certified electrical installer to ensure correct grounding (earthing) of the equipment in accordance with national and local electrical codes and standards.

- Follow all local and national electrical codes to ground electrical equipment properly.
- Proper protective grounding for equipment with ground currents higher the 3.5 mA must be established. See the Leakage current (>3.5 mA) section for details.
- A dedicated ground wire is required for input power, motor power and control wiring.
- Use the clamps provided with the equipment for proper ground connections.
- Do not ground one frequency converter to another in a "daisy chain" fashion.
- Keep the ground wire connections as short as possible.
- Using high-strand wire to reduce electrical noise is recommended.
- Follow motor manufacturer wiring requirements.

Leakage current (>3.5 mA)

Follow national and local codes regarding protective earthing of equipment with a leakage current > 3.5 mA. Frequency converter technology implies high frequency switching at high power. This will generate a leakage current in the earth connection. A fault current in the frequency converter at the output power terminals might contain a DC component which can charge the filter capacitors and cause a transient earth current. The

earth leakage current depends on various system configurations including RFI filtering, screened motor cables, and frequency converter power.

EN/EC61800-5-1 (Power Drive System Product standard) requires special care if the leakage current exceeds 3.5 mA. Earth grounding must be reinforced in one of the following ways:

- Earth ground wire of at least 8 AWG or 10 mm².
- Two separate earth ground wires both complying with the dimensioning rules.

See EN60364-5-54 section 543.7 for further information.

Using GFCIs (RCDs)

Where Ground Fault Circuit Interrupters (GFCIs) and residual current devices (RCDs), also know as earth leakage circuit breakers (ELCDs), are used, comply with the following:

- Use GFCIs (RCDs) of type B only which are capable of detecting AC and DC currents.
- Use GFCIs (RCDs) with an inrush delay to prevent faults due to transient earth currents.
- Dimension GFCIs (RCDs) according to the system configuration and environmental considerations.

Grounding using shielded cable

grounding (earthing) clamps are provided for motor wiring.

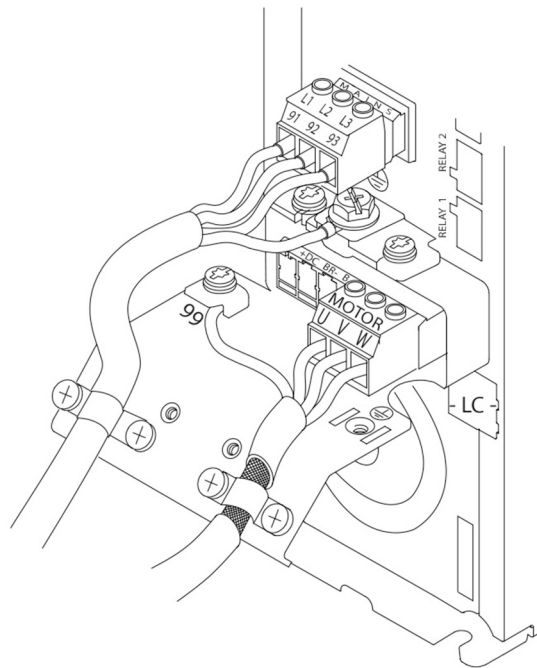

Figure 9: Grounding with shielded cable

5.2 Basic electrical connection

This section contains detailed instructions for wiring the frequency converter. The following tasks are described:

- Wiring the motor to the frequency converter output terminals
- Wiring the AC mains to the frequency converter input terminals
- Connecting control and serial communication wiring
- After power has been applied, checking input and motor power; programming control terminals for their intended functions

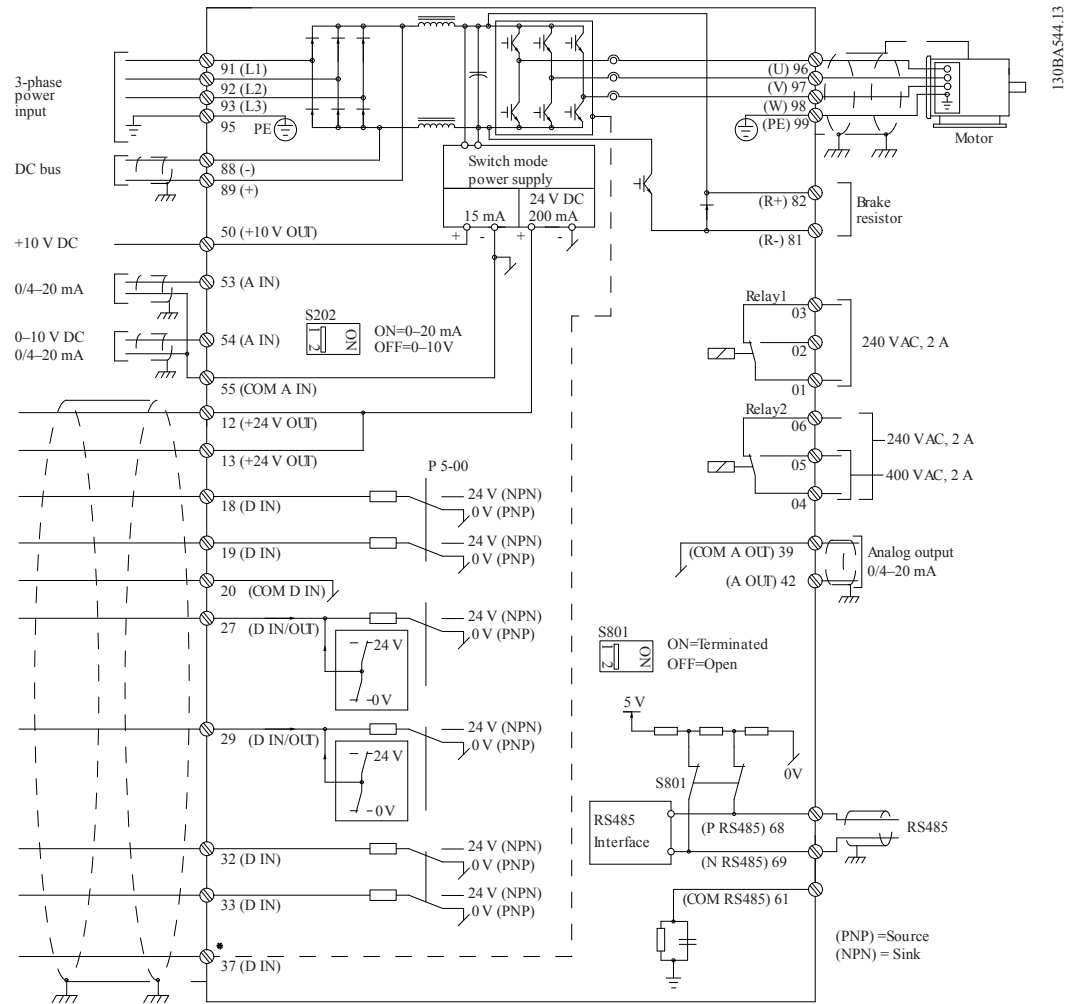

Figure 10: Basic electrical connection

5.3 Motor connection



WARNING:

INDUCED VOLTAGE. Run output motor cables from multiple frequency converters separately. Induced voltage from output motor cables run together can charge equipment capacitors even with the equipment turned off and locked out. Failure to run output motor cables separately could result in death or serious injury.

Be sure the following are adhered to:

- For maximum wire sizes, see [Power-dependent specifications](#).
- Comply with local and national electrical codes
- Motor wiring knockouts or access panels are provided at the base of IP21 (Type 1) and higher units
- Do not install power factor correction capacitors between the frequency converter and the motor
- Do not wire a starting or pole-changing device between the frequency converter and the motor
- Connect the 3-phase motor wiring to terminals 96 (U), 97 (V), and 98 (W)
- Ground the cable in accordance with grounding instructions provided

- Torque terminals in accordance with the information provided in [Tightening torques](#)
- Follow motor manufacturer wiring requirements

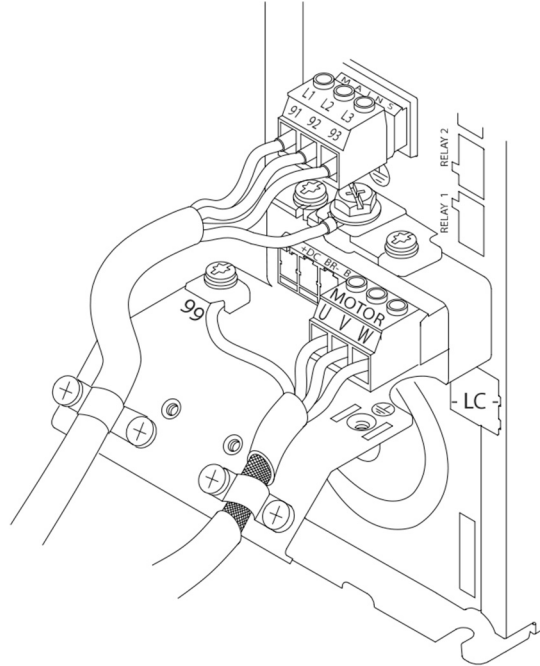

Figure 11: Motor, mains, and earth wiring for frame size A

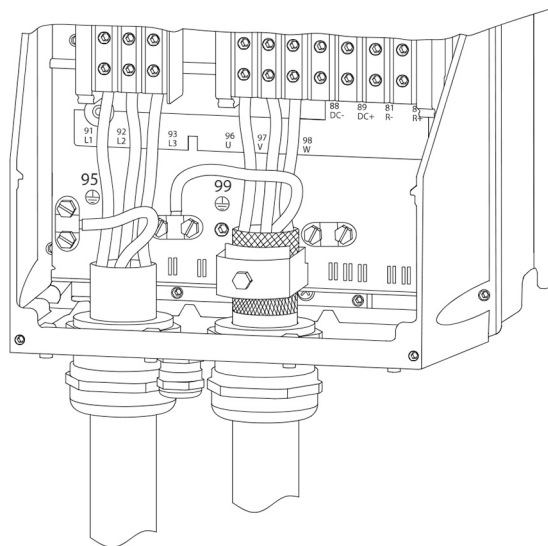

Figure 12: Motor, mains and earth wiring for frame sizes B, C, and D using shielded cable

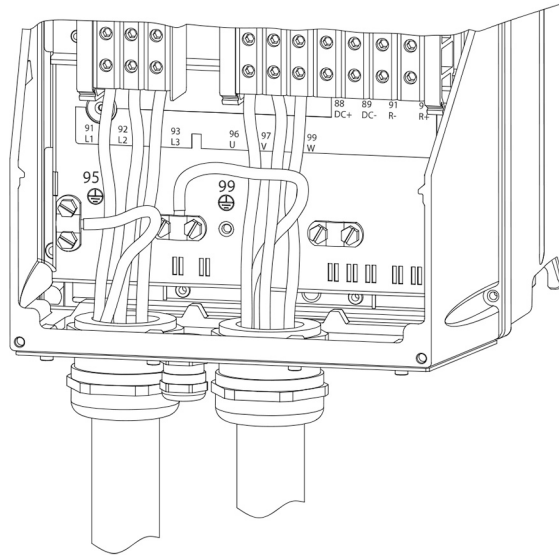
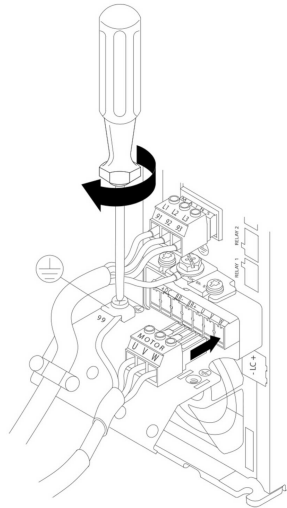

Figure 13: Motor, mains, and earth wiring for frame sizes B, C, and D

5.3.1 Motor connection for A2 and A3

Follow these drawings step by step for connecting the motor to the frequency converter.

1. Connect the motor earthwire to terminal 99, place motor U, V and W wires in plug and tighten.



2. Mount cable clamp to ensure 360° connection between chassis and screen, note the outer insulation of the motor cable is removed under the clamp.

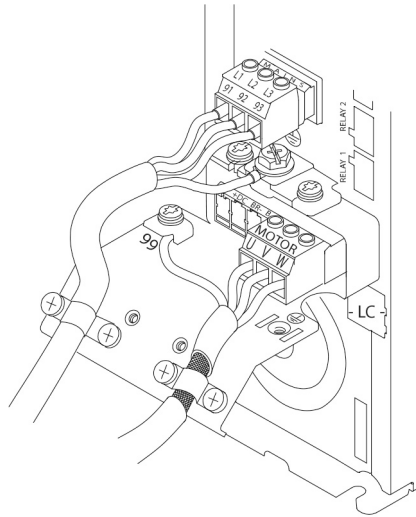

5.3.2 Motor connection for A4 and A5

1. Terminate the motor earth.
2. Place motor U, V and W wires in terminal and tighten.
3. Ensure that the outer insulation of the motor cable is removed under the EMC clamp.

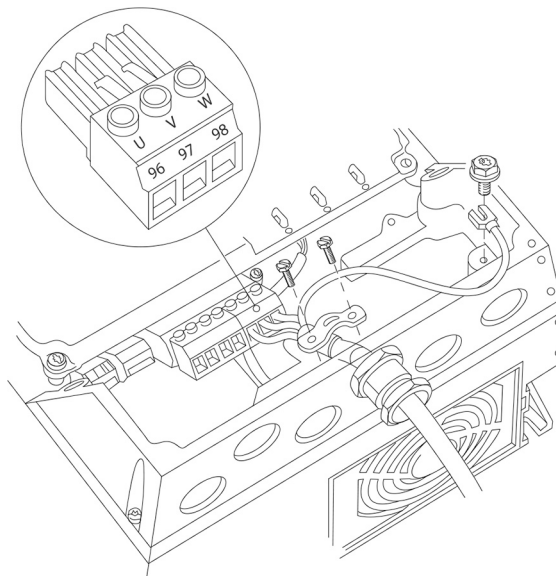

5.3.3 Motor connection for B1 and B2

1. Terminate the motor earth.
2. Place motor U, V and W wires in terminal and tighten.
3. Ensure that the outer insulation of the motor cable is removed under the EMC clamp.

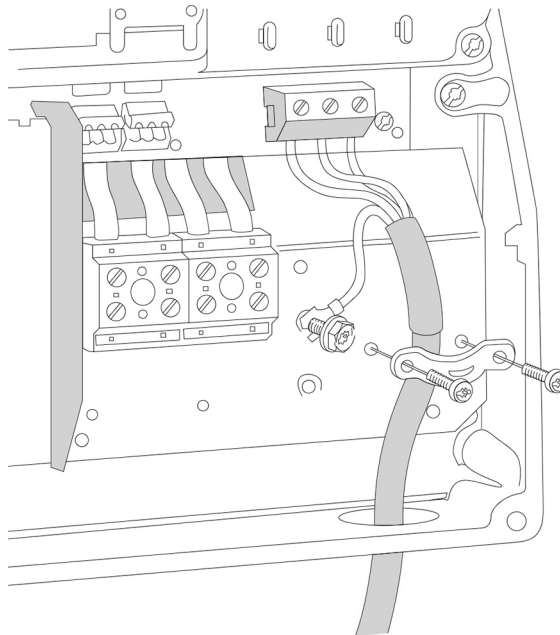

5.3.4 Motor connection for C1 and C2

1. Terminate the motor earth.
2. Place motor U, V and W wires in terminal and tighten.
3. Ensure that the outer insulation of the motor cable is removed under the EMC clamp.

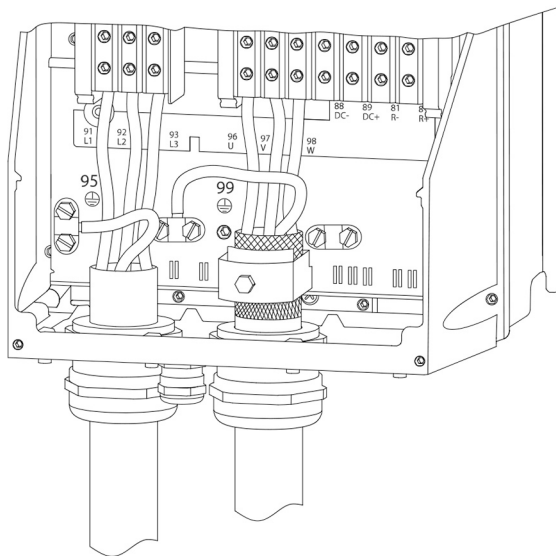

5.3.5 AC mains connection

- Size wiring based upon the input current of the frequency converter. For maximum wire sizes, see Power-dependent specifications section.
- Comply with local and national electrical codes for cable sizes.
- Connect 3-phase AC input power wiring to terminals L1, L2, and L3.

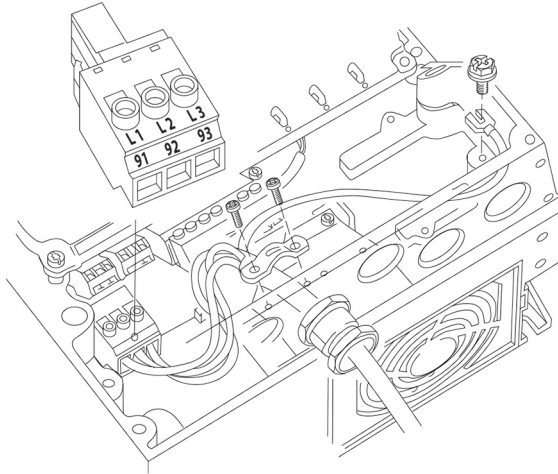

- Depending on the configuration of the equipment, input power will be connected to the mains input terminals or the input disconnect.
- Ground the cable in accordance with grounding instructions in Earth (Grounding) Requirements.
- All frequency converters may be used with an isolated input source as well as with ground reference power lines. When supplied from an isolated mains source (IT mains or floating delta) or TT/TN-S mains with a grounded leg (grounded delta), set 14-50 RFI Filter to OFF. When off, the internal RFI filter capacitors between the chassis and the intermediate circuit are isolated to avoid damage to the intermediate circuit and to reduce earth capacity currents in accordance with IEC 61800-3.

5.3.6 Control wiring

- Isolate control wiring from high power components in the frequency converter.
- If the frequency converter is connected to a thermistor, for PELV isolation, optional thermistor control wiring must be reinforced/double insulated. A 24 V DC supply voltage is recommended.

5.3.7 Control wiring access

- Remove access cover plate with a screwdriver.

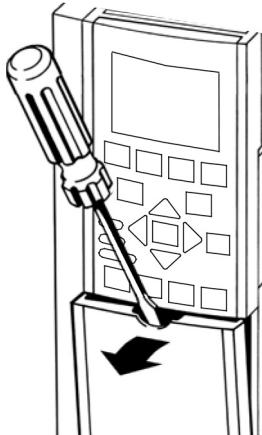

Figure 14: Control wiring access for A2, A3, B3, B4, C3, and C4 enclosures

- Remove front cover by loosening attaching screws.

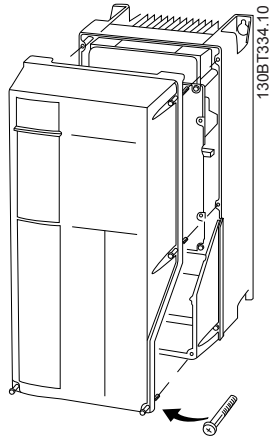

Figure 15: Control wiring access for A4, A5, B1, B2, C1, and C2 enclosures

Table 1: Tightening torques for covers (nM)

Frame	IP20 Open	IP21/Type 1	IP55/Type 3R/12	IP66/Type 4X
A3/A4/A5	–	–	2	2
B1/B2	–	*	2.2	2.2
C1/C2/C3/C4	–	*	2.2	2.2
* No screws to tighten – Does not exist				

5.3.8 Control terminal types

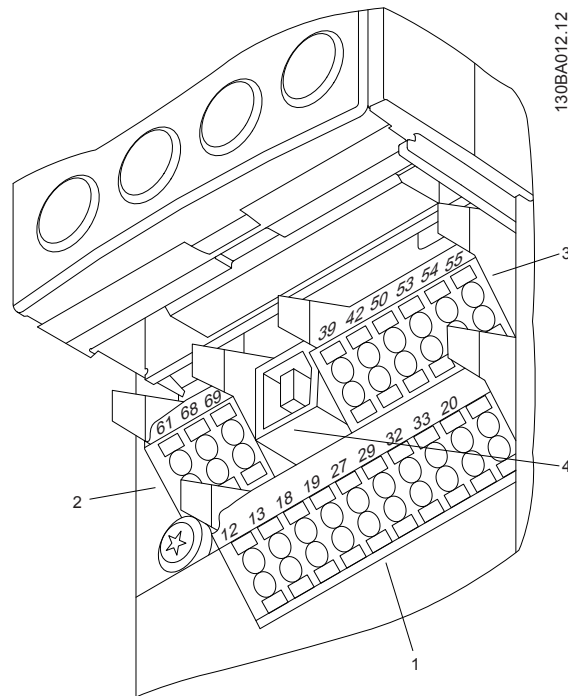

Figure 16: Control terminal locations

- **Connector 1** provides four programmable digital inputs terminals, two additional digital terminals programmable as either input or output, a 24 V DC terminal supply voltage, and a common for optional customer supplied 24 V DC voltage.
- **Connector 2** terminals (+)68 and (-)69 are for an RS-485 serial communications connection.

- **Connector 3** provides two analog inputs, one analog output, 10 V DC supply voltage, and commons for the inputs and output.
- **Connector 4** is a USB port available for use with the frequency converter.
- Also provided are two Form C relay outputs that are in various locations depending upon the frequency converter configuration and size.
- Some options available for ordering with the unit may provide additional terminals. See the manual provided with the equipment option for details and configuration.

Table 2: Terminal descriptions

	Terminal number	Parameter number	Default setting or function	Description
Relay outputs	01, 02, 03	[5-40] Relay 1	[160] No Alarm	Form C Relay output. Usable for AC or DC voltages and either resistive or inductive loads. Refer to Relay wiring for relay contact current and voltage ratings.
	04, 05, 06	[5-40] Relay 2	[5] Running	

	Terminal number	Parameter number	Default setting or function	Description
Digital I/O	12, 13	-	+24V DC	24V DC supply voltage. Maximum output current is 200mA total for all 24V loads. Usable for digital inputs and external transducers.
	18	[5-10]	[8] Start	Start/Stop digital input signal for the drive. Connect input to 24V to start. Open the input to stop. This is a required connection.
	19	[5-11]	[0] No Operation	Unused digital input. This input can be configured for use as a Pump Protect/ External Interlock Warning or Alarm Input. See Pump protect to enable the Warning or Alarm associated with this input.
	27	[5-12]	[0] No Operation	Unused digital input. This input can be configured for use as a Pump Protect/ External Interlock Warning or Alarm Input. See Pump protect to enable the Warning or Alarm associated with this input.
	29	[5-13]		
	32	[5-14]	[1] Reset	Digital input. Configured for use as a Reset for the No Water/Loss of Prime Restart function. Refer to Pump protect for details.
	33	[5-15]		Digital input. Configured for use as a Setpoint 1/Setpoint 2 select (SP1/SP2).
	20	-	Common	Common for digital inputs and reference for 24V supply

	Terminal number	Parameter number	Default setting or function	Description
Analog I/O	39	-	AO Common	Common for analog output
	42	[6-50]	[137] Speed 4-20 mA	Analog output. Default setting is 4-20mA signal (500Ω max) based on motor speed. Range is 0 to max speed indicated in [4-14].
	50	-	+10V DC	10V DC analog supply voltage. 15mA maximum.
	53	[6-1*]	Transducer feedback	Analog Input 53. Default configuration is 300 psi, 4-20mA pressure transducer input.
	54	[6-2*]	Not Used	Analog Input 54
	55	-	AI Common	Common for analog input
Comm.	61	-	Shield Connection	Integrated RC filter for cable shield. ONLY for connecting the shield when experiencing EMC problems.
	68	[8-3*]	+	RS485 interface +
	69	[8-3*]	-	RS485 interface -

5.4 Wiring to control terminals

5.4.1 Unplug terminal connectors

Control terminal connectors can be unplugged from the frequency converter for ease of installation.

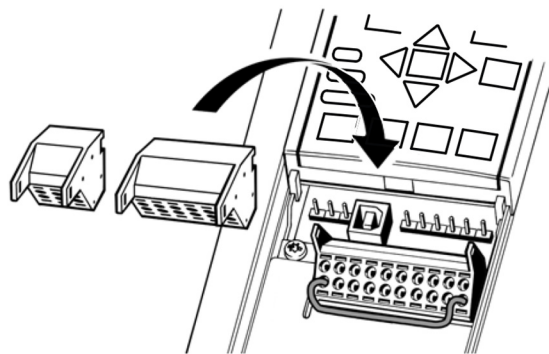

5.4.2 Control terminal connections

Connecting to the control terminals

1. To connect control wiring to the control terminals, do the following:
 - a. Strip the control wire back 9-10mm (0.35-0.40 in)
 - b. Insert a screwdriver (2.5-3.5 mm) in the rectangular hole in between two circular holes and push it down.

- c. Insert the cable in the adjacent circular hole.
 - d. Remove the screwdriver. The wire is now mounted to the terminal.
2. To remove the wire from the terminal:
 - a. Insert a screwdriver (2.5–3.5 mm) in the rectangular hole and push it down.
 - b. Pull out the cable.

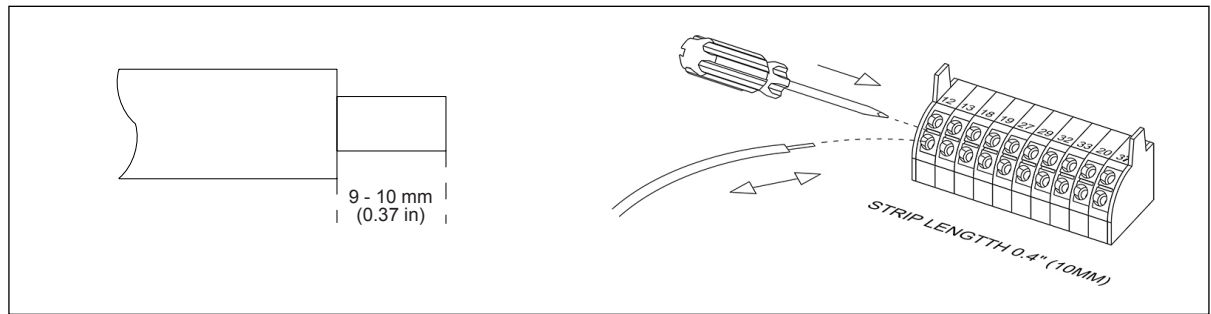

Figure 17: Connecting and disconnecting control wiring

Analog input configuration

There are two analog input switches, A53 is fixed to Current (4-20mA) only; whereas, the A54 input switch can be selected as Voltage (0-10V) or Current (4-20mA).

- Switch A53 is fixed to current type and not configurable.
- Switch A54 is used to configure analog input 54.

If the analog input 54 is used, the analog input configuration switch A54 must be set properly.

- Remove power from the controller before changing the analog input configuration switches.
- Remove the local control panel.
- To configure the analog input 54 as a voltage input, set the configuration switch A54 to U (set to the left position).
- Set the configuration switch A54 to I (set to the right position) to enable the input as a current input.

Transducer voltage or current type of switch A54 can be verified at parameter [16-63]

Terminal 54 Switch Setting. NOTE: [16-61] **Terminal 53 Switch Setting** always displays current type.

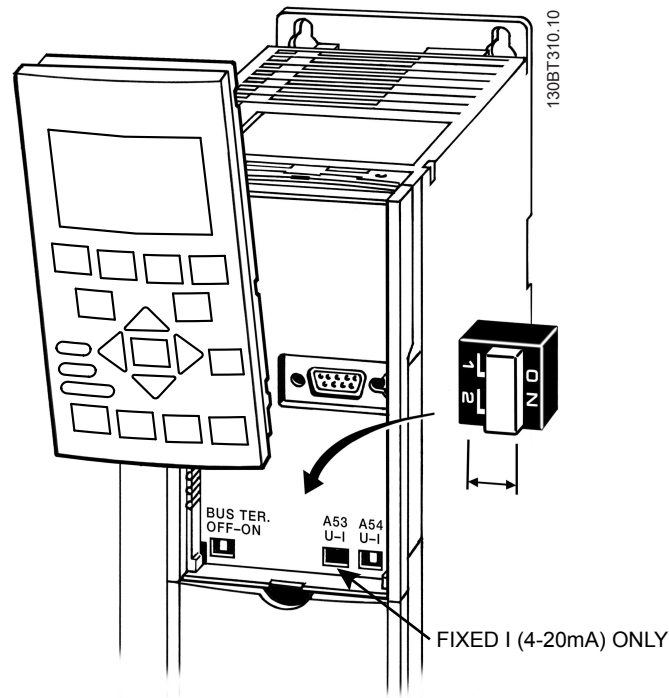

Figure 18: Configuration switch location

**WARNING:**

Some option cards available for the unit may cover these switches and must be removed to change switch settings. Always remove power to the unit before removing option cards.

5.4.3 Control terminal functions

Frequency converter functions are commanded by receiving control input signals.

- Each terminal must be programmed for the function it will be supporting in the parameters associated with that terminal.
- It is important to confirm that the control terminal is programmed for the correct function. See the [Local control panel](#) for detail on accessing parameters and [Programming the controller](#) for details on programming.
- The default terminal programming is intended to initiate frequency converter functioning in a single pump, constant pressure operating mode.

5.4.4 Analog input 53

The default operating mode of the frequency converter is Single Pump, Constant Pressure mode. In this mode a current feedback signal from a transducer, PLC or other device is required on Analog Input 53 (AI 53) that allows the use of a 300psi, 4-20mA pressure transducer.

When using the supplied pressure transducer:

1. Connect the feedback (white wire) from the transducer cable to AI 53
2. Connect the power wire (brown wire) to terminal 12 or 13 (24V dc)
3. In cases where the transducer is mounted on ungrounded piping, connect the drain (bare wire) to the spring loaded cable strain relief clamps found below the control terminals.

5.4.5 Jumper terminals 12 and 18

The frequency converter has been configured to require a start command on terminal 18. To apply a start signal connect the device used to control starting of the drive or a jumper

wire between terminals 18 (DI 18, parameter 5-10) and 12 (24V dc). A start command is given to the controller when terminal 18 is connected to 24V.

5.4.6 Using screened control cables

Correct screening

The preferred method in most cases is to secure control and serial communication cables with screening clamps provided at both ends to ensure best possible high frequency cable contact.

If the earth potential between the frequency converter and the PLC is different, electric noise may occur that will disturb the entire system. Solve this problem by fitting an equalizing cable next to the control cable. Minimum cable cross section: 6 AWG or 16 mm².

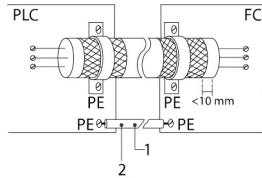

Figure 19: Correct screening

1	Min. 6 AWG or 16 mm ²
2	Equalizing cable

50/60 Hz ground loops

With very long control cables, ground loops may occur. To eliminate ground loops, connect one end of the screen-to-ground with a 100 nF capacitor (keeping leads short).

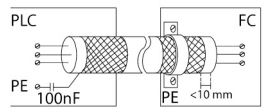

Figure 20: 50/60 Hz ground loops

Avoid EMC noise on serial communication

This terminal is connected to earth via an internal RC link. Use twisted-pair cables to reduce interference between conductors.

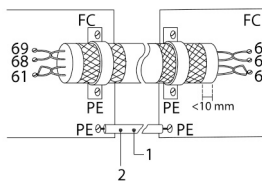

Figure 21: Twisted-pair cables

1	Min. 6 AWG or 16 mm ²
2	Equalizing cable

Alternatively, the connection to terminal 61 can be omitted:

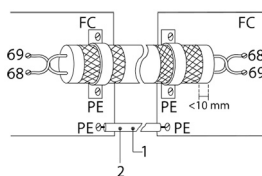

Figure 22: Twisted-pair cables without terminal 61

1	Min. 6 AWG or 16 mm ²
2	Equalizing cable

5.4.7 Serial communication

RS-485 is two-wire bus interface compatible with multi-drop network topology. For example, nodes can be connected as a bus, or via drop cables from a common trunk line. A total of 32 nodes can be connected to one network segment. Repeaters divide network segments. Note that each repeater functions as a node within the segment in which it is installed. Each node connected within a given network must have a unique node address, across all segments. Terminate each segment at both ends, using either the termination switch (BUS TER./S801) of the frequency converters or a biased termination resistor network. Always use screened twisted pair (STP) cable for bus cabling, and always follow good common installation practice.

Low-impedance ground (earth) connection of the screen at every node is important, including at high frequencies. Thus, connect a large surface of the screen to ground (earth), for example with a cable clamp or a conductive cable gland. It may be necessary to apply potential-equalizing cables to maintain the same ground (earth) potential throughout the network. Particularly in installations with long cables.

To prevent impedance mismatch, always use the same type of cable throughout the entire network. When connecting a motor to the frequency converter, always use screened motor cable.

Table 3: Cable information

Cable	Screened twisted pair (STP)
Impedence	120 Ω
Max. cable length [m]	1200 including drop lines 500 station-to-station

5.5 Common terminal wiring configurations

Relay wiring

Each controller has two programmable form C relay outputs. The relay terminals are located in various locations on the controller depending on the frame size. NOTE: Relay functions can be enabled using the Start-up Genie.

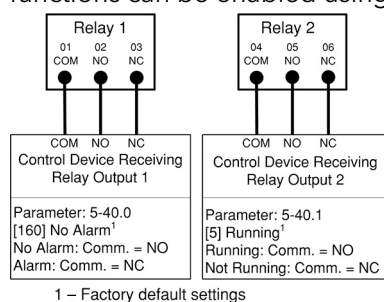

Figure 23: Relay terminal wiring

Table 4: Relay terminal ratings

Programmable relay outputs	2
Relay 01 Terminal number	1-3 (break), 1-2 (make)
Maximum terminal load (AC-1) ¹ on 1-3 (NC), 1-2 (NO) (Resistive load)	240 V AC, 2A
Maximum terminal load (AC-15) ¹ (Inductive load @ cosφ 0.4)	240 V AC, 0.2A
Maximum terminal load (DC-1) ¹ on 1-2 (NO), 1-3 (NC) (Resistive load)	60 V DC, 1A
Maximum terminal load (DC-13) ¹ (Inductive load)	24 V DC, 0.1A

Relay 02 Terminal number	4-6 (break), 4-5 (make)
Maximum terminal load (AC-2) ¹ on 4-5 (NO) (resistive load) ^{2,3}	400 V AC, 2A
Maximum terminal load (AC-15) ¹ (Inductive load @ cosφ 0.4)	240 V AC, 0.2A
Maximum terminal load (DC-1) ¹ on 4-5 (NO) (Resistive load)	80 V DC, 2A
Maximum terminal load (DC-13) ¹ on 4-5 (NO) (Inductive load)	24 V DC, 0.1A
Maximum terminal load (AC-1) ¹ on 4-6 (NC) (Resistive load)	240 V AC, 2A
Maximum terminal load (AC-15) ¹ on 4-6 (NC) (Inductive load @ cosφ 0.4)	240 V AC, 0.2A
Maximum terminal load (DC-1) ¹ on 4-6 (NC) (Resistive load)	50 V DC, 2A
Maximum terminal load (DC-13) ¹ on 4-6 (NC) (Inductive load)	24 V DC, 0.1A
Minimum terminal load on 1-3 (NC), 1-2 (NO), 4-6 (NC), 4-5 (NO)	24 V DC 10mA, 24 V AC 20mA
Environment according to EN 60664-1	overvoltage category III/pollution degree 2

Wiring for factory default setup

This configuration utilizes the controller factory default settings for I/O. The factory default settings for IT are configured for a single pump, constant pressure application with a 300 psi, 4-20mA pressure transducer wired to AI 53. A jumper wire is needed between terminals 29 and 32 to enable the No Water/Loss of Prime Restart function. A Start signal is applied on Digital Input 18. The controller will receive a Start command when DI 18 is connected to 24V. There are no parameters that need to be adjusted for this configuration. Refer to Commissioning section for details on configuring the controller and changing application settings.



CAUTION:

When a Start (Closed) signal is present on DI18, the controller can start the pump/motor at any time without warning. Set DI18 to Stop (Open) or press the [Off] operation key before using the Genie. Apply the Start signal to the controller only when pump/motor operation is desired.

NOTICE:

The factory default settings are configured to require a start signal wired to DI18 as shown below.

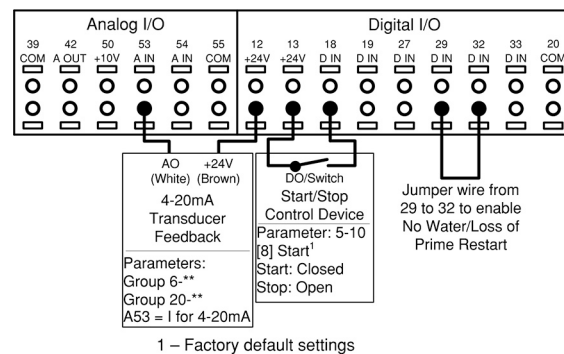

Figure 24: Required terminal connections for use with factory default settings

Pump protect

A Pump Protect function can be used to turn off the controller and issue an alarm (Pump Protect Alarm 60) when system pressures, temperatures, levels, etc. are outside of the normal operating range for the system. The Pump Protect function can be configured on digital input 19 and digital input 27. These inputs can be controlled by an external device such as a suction pressure switch, an over pressure switch, a temperature switch, a differential pressure switch, etc. The device chosen should be normally closed. The [22-00] **Pump Protect Delay** parameter can be configured to delay the onset of the Pump

Protect Alarm to prevent nuisance tripping. When the input is disconnected from the 24V supply, the delay timer will start. If the input remains disconnected for the time indicated in [22-00]**Pump Protect Delay**, the controller stops the motor and issues *Alarm 60 Protect Protect*. If a Pump Protect Alarm is issued, the controller will attempt to restart if the [14-20] **Reset Mode** parameter and the [14-21] **Automatic Restart Time** parameter are set to allow automatic restarting. To prevent an automatic restart set the [14-20] **Reset Mode** to Manual Reset. Note that the [14-20] **Reset Mode** parameter affects all other Alarms that are not listed as a Trip Lock Alarm. Refer to the Warnings/Alarm Messages section for details.

NOTE: This function can be enabled using the Start-Up Genie.

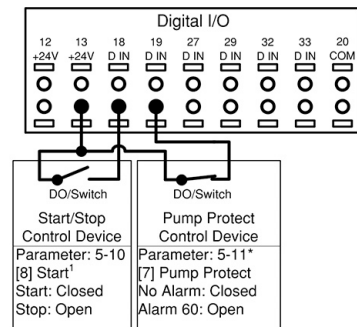

1 – Factory default settings

* – DI 27 can also be configured for the Pump Protect Function. To use DI 27, connect the control device between 13 and 27. Set parameter 5-12 to [7] Pump Protect.

Figure 25: Connections for adding Pump Protect

Table 5: Parameter settings for enabling a Pump Protect Alarm on DI19

Parameter number	Parameter description	Set to
[5-11]*	Terminal 19 Digital Input	Pump Protect
[22-00]	Pump Protect Delay	Set to the desired delay time. If set to 10 seconds, the Pump Protect Alarm will be issued 10 seconds after the input is disconnected from 24V. The input must remain disconnected for the entire delay time for the alarm to be issued.
[14-20]	Reset Mode	Set to the desired number of automatic resets. If a fault occurs more than this setting, a manual reset is required. Set to Manual Reset if no resets are allowed. Default setting is: Automatic reset x 3.
[14-21]	Automatic Restart Time	This is the time between when an alarm/warning is issued and when the controller attempts the next restart. Default setting is 30 seconds.

* To configure DI 27, set [5-12] to Pump Protect.

Configuring an additional transducer feedback

An additional transducer can be added to the system to work with closed loop control or for external monitoring. The additional transducer can be either a voltage output or current output transducer. The additional transducer can be added to the unused analog input (AI 53 for current type only or AI 54 for current type or voltage type). The wiring below shows the required connections for an additional transducer on AI 54.

A common use of two pressure transducer feedback signals is to take the difference between the signals to create a differential pressure transducer. To implement a

differential pressure transducer with 2 pressure transducers, set [20-20] **Feedback Function** to Difference. The controller will calculate the feedback value as [20-00] **Feedback 1 Source** - [20-03] **Feedback 2 Source**. Be sure to set all unused feedback sources to No Function (parameters [20-00], [20-03] or [20-06]). The parameter listing that follows shows how to configure the additional transducer.

- Analog inputs can be configured using the Start-Up Genie.
- Be sure to properly set the analog input configuration switch prior to using the analog input. Refer to the Analog input configuration (Switches A53 and A54) for details.

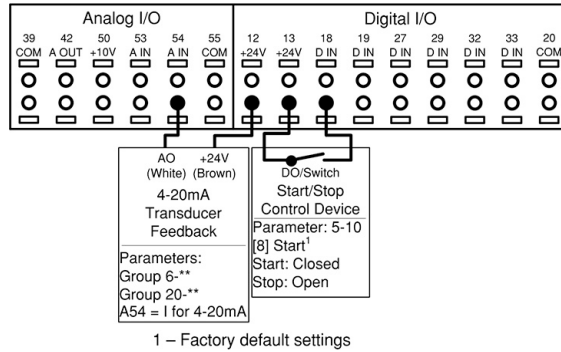

Figure 26: Connections for adding 4-20 mA transducer feedback to AI 54

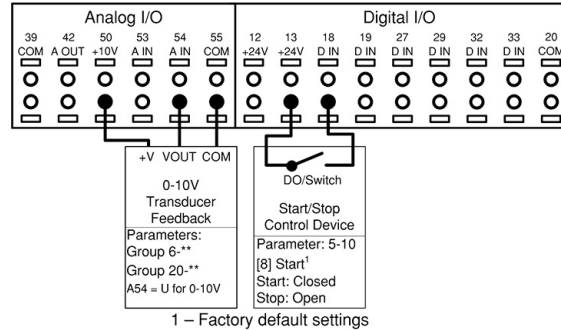

Figure 27: Connections for adding 0-10 V transducer feedback to AI 54

In order to set up the controller for closed loop control based on the feedback from an external transducer, set the following parameters:

Table 6: Parameter settings to enable an additional transducer on AI 54

Parameter Number	Parameter Description	Set To
[6-24]*	Terminal 54 Low Ref./Feedb.Value	Minimum transducer feedback value. For example, for a 0-300psi transducer, set to 0.
[6-25]*	Terminal 54 High Ref./Feedb.Value	Maximum transducer feedback value. For example, for a 300psi transducer, set to 300.
[6-27]*	Terminal 54 Sensor Fault (North America) / Live Zero (International)	Enabled
[20-03]	Feedback 2 Source	Analog Input 54*
[20-05]	Feedback 2 Source Unit	Units for the second feedback source. For a differential pressure transducer, use the same units as found in 20-02, psi is default
[20-12]	Reference/Feedback Unit	Select as appropriate for application. For example, set to psi when using pressure feedback.

Parameter Number	Parameter Description	Set To
[20-13]	Minimum Reference/Feedb.	Minimum transducer feedback value. For example, for a 0-300psi transducer, set to 0.
[20-14]	Maximum Reference/Feedb.	Maximum transducer feedback value. For example, for a 300psi transducer, set to 300.

* To use AI 53, configure parameters [6-14], [6-15], [6-17] to Analog Input 53 that has only a current-type input.

Table 7: Parameters for an additional transducer used for monitoring

Parameter number	Description	Set to
[0-24]	Display Line 3 Large	Ext. 1 Feedback [Unit]
[21-14]	Ext.1 Feedback Source	Analog Input 54*
[21-10]	Ext.1 Ref./Feedback Unit	Select as appropriate for application. For example, set to psi when using a pressure transducer.
[21-11]	Ext.1 Minimum Reference	Minimum transducer feedback value. For example, for a 0-300psi transducer, set to 0 psi.
[21-12]	Ext.1 Maximum Reference Ext. 1 Maximum Reference	Maximum transducer feedback value. For example, for a 300 psi DP transducer, set to 300 psi.
[6-24]*	Terminal 54 Low Ref./Feedb.Value	Minimum transducer feedback value. For example, for a 0-300 psi transducer, set to 0.
[6-25]*	Terminal 54 High Ref./Feedb.Value	Maximum transducer feedback value. For example, for a 300 psi transducer, set to 300.
[6-27]*	Terminal 54 Sensor Fault (North America) / Live Zero (International)	Disabled

* To use AI 53, configure parameters [6-14], [6-15], [6-17] and set [21-14] to Analog Input 53 that has only a current-type input.

Speed control through an analog input

The controller can be configured for speed control through an analog input. The controlling source can be either an external control device such as a PLC, BMS (building management system) or potentiometer. The output from the external control device can be either a voltage or current output signal. Be sure to set the analog input configuration switches based on the type of output signal. The diagrams below show the connections for an external speed command.

- Speed control mode can be configured using the Start-Up Genie.

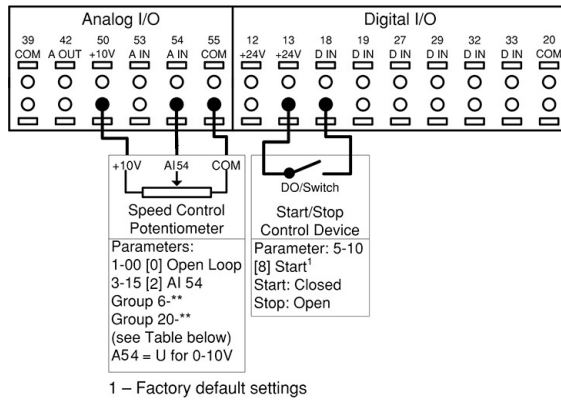

Figure 28: Connections for speed control with external potentiometer

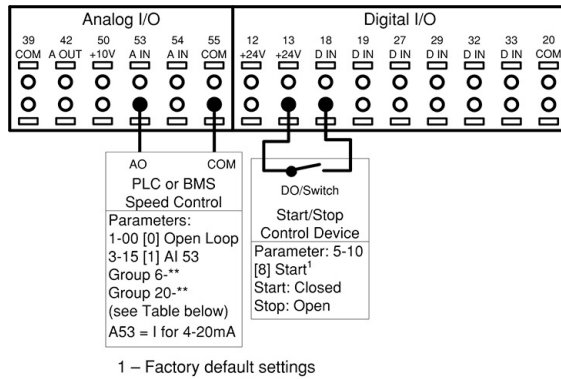

Figure 29: Connections for speed control over current signal from PLC or BMS

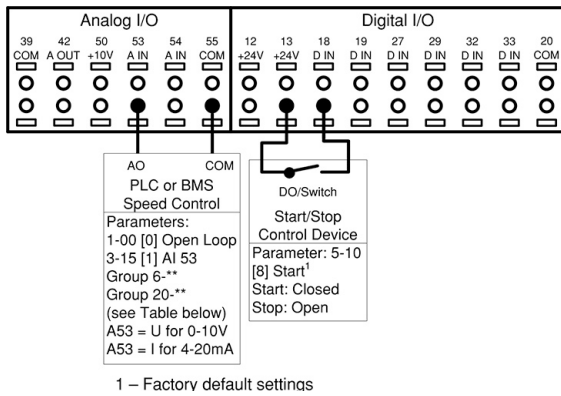

Figure 30: Connections for speed control with PLC or BMS

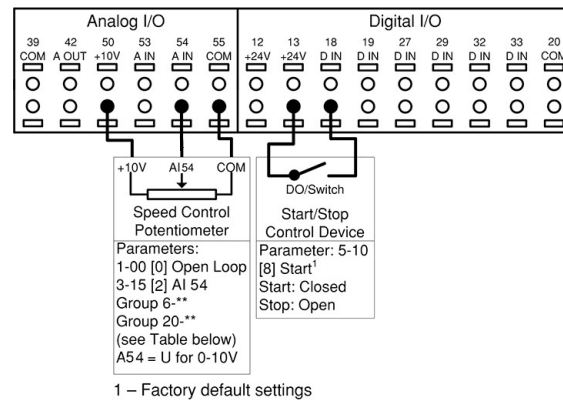

Figure 31: Connections for speed control over voltage signal from PLC or BMS

Table 8: Parameters for speed control from external potentiometer, PLC or BMS

Parameter number	Description	Set to
[1-00]	Configuration Mode	Open Loop
[3-02]	Minimum Reference	Set to value corresponding to desired speed at the minimum reference
[3-03]	Maximum Reference	Set to value corresponding to desired speed at the maximum reference
[3-15]	Reference 1 Source	Analog Input 53
[6-12]	Terminal 53 Low Current	4 mA
[6-13]	Terminal 53 High Current	20 mA
[6-14]	Terminal 53 Low Ref./Feedb.Value	Set to value corresponding to the commanded speed at the low current.
[6-15]	Terminal 53 High Ref./Feedb.Value	Set to value corresponding to the commanded speed at the high current.
[6-17]	Terminal 53 Sensor Fault (North America) / Live Zero (International)	Disabled
[2000]	Feedback 1 Source	No Function

NOTE: For speed control over voltage signal:

- Set switch A54 = U (left position).
- Set [3-15] **Reference 1 Source** = Analog Input 54.
- Set [6-20] **Terminal 54 Low Voltage** = 0 V and [6-21] **Terminal 54 High Voltage** = 10 V.
- Set [6-24] **Terminal 54 Low Ref./Feedb.Value** to value corresponding to the command speed at the low voltage and [6-25] **Terminal 54 High Ref./Feedb.Value** to value corresponding to the command speed at the high voltage.
- Set [6-27] **Terminal 54 Sensor Fault (North America) / Live Zero (International)** to Disable.

Control from external PLC/BMS through Analog Input

The controller can be configured to accept either the process variable (e.g. actual pressure) or setpoint from an external control source such as a PLC or BMS controller through an analog input. The output from the external control device can be either a voltage or current output signal. Be sure to set the analog input configuration switches based on the type of output signal. When the process variable is supplied by the external controller, the wiring connections are the same as used with the connections for speed control from an external device through an analog input. When the setpoint or reference is supplied to the controller from the external device both a transducer and the external

control device supplying the setpoint need to be connected to the controller. Refer to the wiring diagram below. The parameter settings for this configuration are shown below.

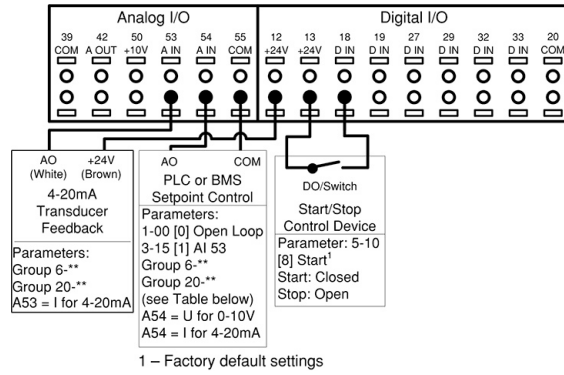

Figure 32: Connections for setpoint control through an external device

Table 9: Parameters for external PLC/BMS

Parameter Number	Parameter Description	For setpoint from BMS/PLC
[3-15]	Reference 1 Source	[6-2] Analog Input 54
[6-22]*	Terminal 54 Low Current	Minimum current value for the signal from the BMS/PLC.
[6-23]*	Terminal 54 High Current	Maximum current value for the signal from the BMS/PLC.
[6-25]	Terminal 54 High Ref./Feedb.Value	Maximum reference/setpoint value. For example, for a 300psi maximum setpoint, set to 300.
[6-27]	Terminal 54 Sensor Fault (North America) / Live Zero (International)	Enabled
[20-00]	Feedback 1 Source	Select as appropriate for application. This can be any selection except the setting of [3-15] Reference 1 Source .
[20-12]	Reference/Feedback Unit	Select as appropriate for application. For example, set to psi when using pressure reference.
[20-13]	Minimum Reference/Feedb.	Minimum reference/setpoint value. For example, for a 0-300psi transducer, set to 0 psi.
[20-14]	Maximum Reference/Feedb.	Maximum reference/setpoint value. For example, for a 300psi transducer, set to 300 psi.

* To use a voltage signal from the PLC/BMS, configure parameters [6-20], [6-21], and set switch A54 to U.

Duplex control wiring

The controller can be configured to operate in a duplex control system having 2 controllers and 2 variable speed pumps. In this configuration pumps can be staged and destaged as needed and the lead pump can be alternated. When both pumps are on they operate at the same frequency. To configure the controller for this type of system, a specific wiring configuration is required. The diagram below shows the wiring required to implement the duplex control system.

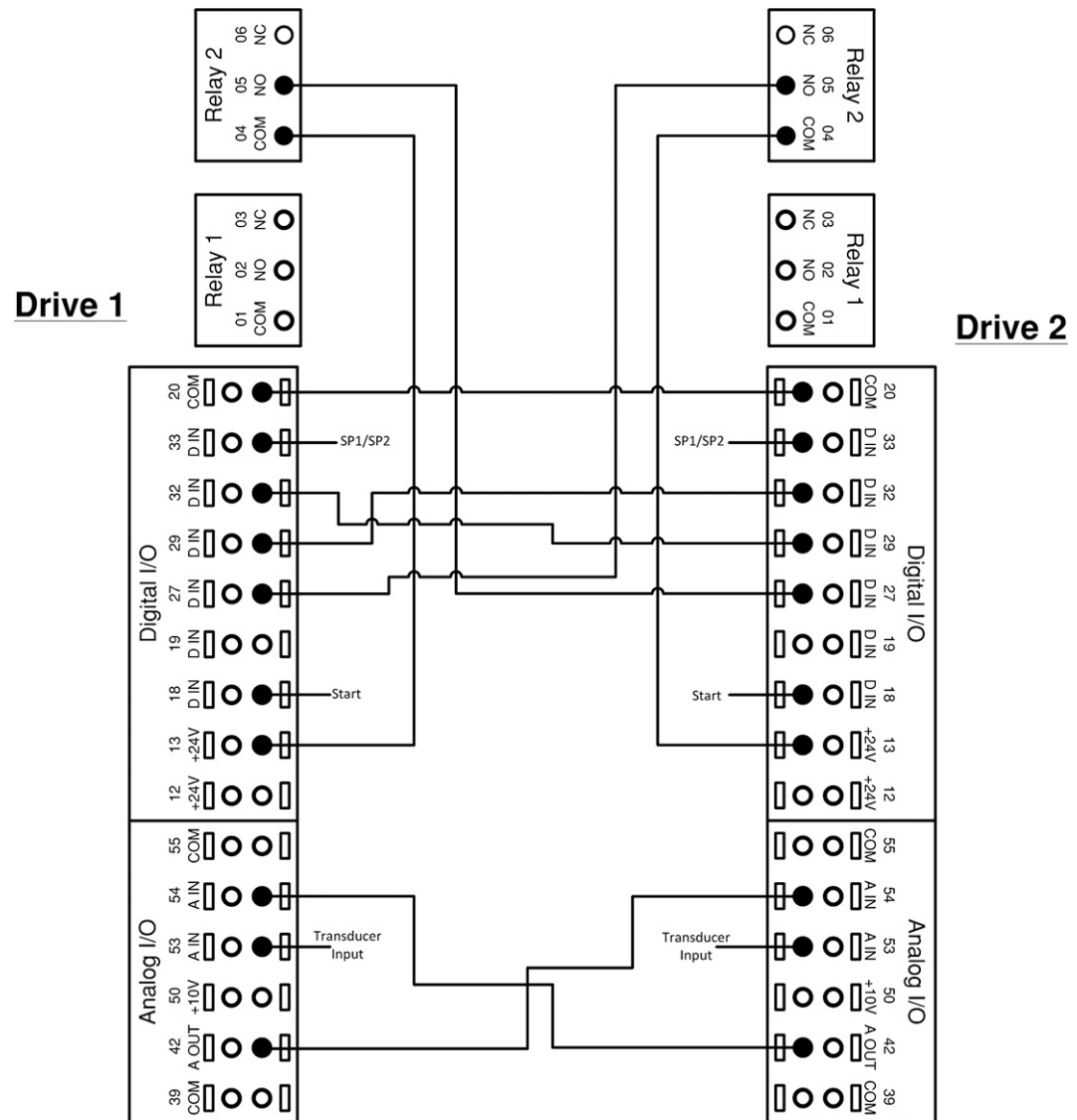

Figure 33: Duplex wiring

Duplex Control Mode requires a specific set of parameters in order to ensure proper functionality. The Start-Up Genie must be used to configure the Duplex Control Mode. See the Commissioning section for details.

Control from external PLC/BMS through communications port

A BMS or PLC can be connected to the control through the communications port. In this configuration, the BMS or PLC can control the drive by overriding the setpoint, supplying the process variable or by providing a speed command to the drive. Control cables must be braided screened/shielded and the screen must be connected by means of a cable clamp at the controller and at the BMS/PLC. Refer to Using Screened Control Cables for details on installing shielded/screened cables. The parameter list in the table below shows parameters used to configure communication for two common protocols, Modbus RTU and BACnet. The parameter list in the second table below shows parameters that determine the control source for certain drive functions. Use these parameters to determine whether digital inputs or the BMS/PLC has control of the function.

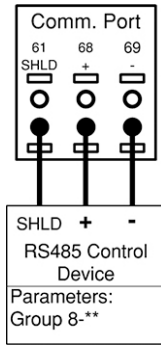

Figure 34: Connections for external control source connected through comm. port

Table 10: Parameter settings for Modbus RTU and BACnet protocols

Parameter Number	Parameter Description	Protocol	
		Modbus RTU	BACnet
[8-02]	Control Source	FC Port	FC Port
[8-30]	Protocol	Modbus RTU	BACnet
[8-31]	Address	1	1
[8-32]	Baud Rate	19200	9600
[8-33]	Parity / Stop Bits	Even Parity, 1 Stop bit	No Parity, 1 Stop bit
[8-34]	Estimated Cycle Time	0 ms	0 ms
[8-35]	Minimum Response Delay	10 ms	10 ms
[8-36]	Maximum Response Delay	5000 ms	5000 ms
[8-37]	Maximum Inter-Char Delay	0.86 ms	25 ms

Table 11: Parameters determining control source for controller functions

Parameter number	Description	Set to
[8-01]	Control Site	Determines the location of the control source. Set to Digital and ctrl.word to use both serial bus and digital input control. Set to Digital only to use only the digital inputs. Set to Controlword only to use only the serial bus.
[8-50]	Coasting Select	Determines the control location of the coasting (stop) function. Set to Digital input to use a digital input only. Set to Bus to use only the serial bus only. Set to Logic AND to use the serial bus AND a digital input. Set to Logic OR to use the serial bus OR a digital input.
[8-53]	Start Select	Determines the control location of the start command. Set to Digital input to use a digital input only. Set to Bus to use only the serial bus only. Set to Logic AND to use the serial bus AND a digital input. Set to Logic OR to use the serial bus OR a digital input.
[8-55]	Set-up Select*	Determines the control location of the set-up selection function. Set to Digital input to use a digital input only. Set to Bus to use only the serial bus only. Set to Logic AND to use the serial bus AND a digital input. Set to Logic OR to use the serial bus OR a digital input.

Parameter number	Description	Set to
[8-56]	Preset Reference Select*	Determines the control location of the preset reference selection function. Set to Digital input to use a digital input only. Set to Bus to use only the serial bus only. Set to Logic AND to use the serial bus AND a digital input. Set to Logic OR to use the serial bus OR a digital input.

* The Set-up Select and Preset Reference Select functions are used to control other pre-configured functions in the controller. To avoid interfering with these functions, it is recommended to control this function via digital inputs.

5.6 Local control panel

The controller is equipped with a local control panel (LCP). The LCP combines the status screen and keypad found on the front of the controller. The LCP is the user interface to the controller. The LCP allows the user to perform various functions such as:

- Start, stop and control speed with the keypad when in local/Hand mode
- View and display the status of the controller, pump and system
- Provides access to all parameters and start up functions
- Manually reset the controller after a fault
- Perform parameter backup

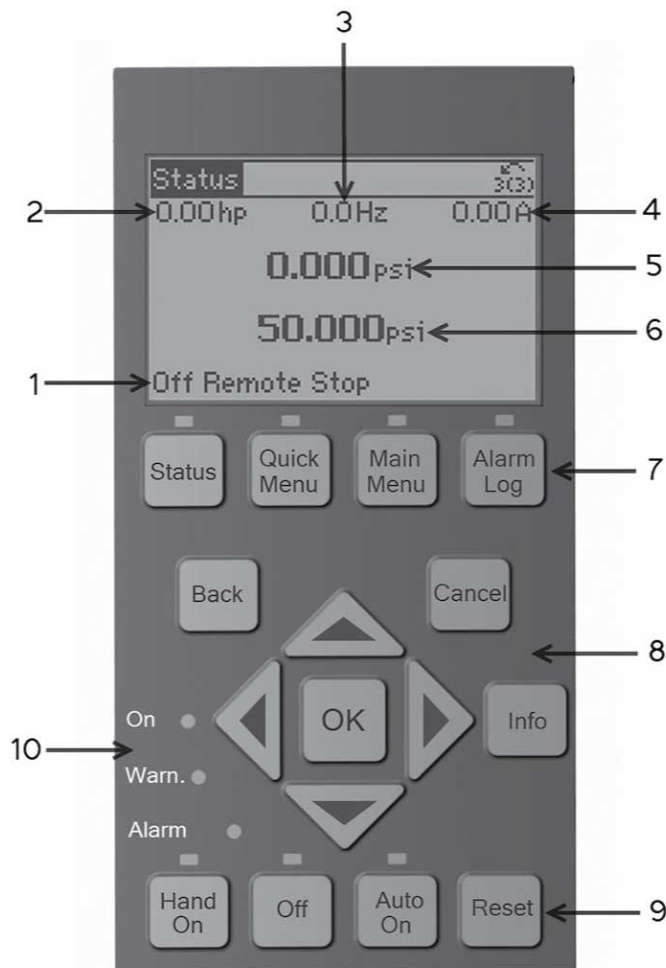

Figure 35: Default configuration

1. Controller Status
2. Motor HP (Parameter [0-20])
3. Motor Frequency (Parameter [0-21])
4. Motor Current (Parameter [0-22])
5. Feedback/Actual Pressure or process variable (Parameter [0-23])
6. Setpoint (Parameter [0-24])
7. Menu keys
8. Navigation keys
9. Operation keys
10. Status lights

The parameters shown are the factory default settings. To display other values, modify parameters [0-20], [0-21], [0-22], [0-23], or [0-24].

Controller status

The controller status line shows operational information about the controller.

The first word in the status line shows the Operation Mode. The table below defines the Operation Mode status.

Off	The controller does not react to any control signal until [Auto On] is pressed.
Auto On	The controller is controlled from the control terminal and/or the serial communication.
Hand On	The controller can be controlled by the navigation keys on the LCP. Stop commands, reset, reversing, DC brake, and other signals applied to the control terminals can override local control.

The second word in the status line shows the Reference Site.

Remote	The speed reference is given from external signals, serial communication, or internal preset references.
Local	The controller converter uses [Hand On] control or reference values from the LCP.

The third word in the status line shows the Operation Status.

AC Brake	AC Brake was selected in [2-10] Brake Function . The AC brake over-magnetizes the motor to achieve a controlled slow down.
AMA finish OK	Automatic motor adaptation (AMA) was carried out successfully.
AMA ready	AMA is ready to start. Press [Hand On] to start.
AMA running	AMA process is in progress.
Braking	The brake chopper is in operation. Generative energy is absorbed by the brake resistor.
Braking max.	The brake chopper is in operation. The power limit for the brake resistor defined in [2-12] Brake Power Limit (kW) has been reached.
Coast	<ul style="list-style-type: none"> • Coast inverse was selected as a function for a digital input (parameter group [5-1]* Digital Inputs). The corresponding terminal is not connected. • Coast activated by serial communication.

Ctrl. Ramp-down	Control Ramp-down was selected in [14-10] Mains Failure . <ul style="list-style-type: none"> The mains voltage is below the value set in [14-11] Mains Voltage at Mains Fault The controller ramps down the motor using a controlled ramp down
Current high	The controller output current is above the limit set in [4-51] Warning Current High .
Current Low	The controller output current is below the limit set in [4-52] Warning Speed Low .
DC Hold	DC hold is selected in [1-80] Function at Stop and a stop command is active. The motor is held by a DC current set in [2-00] DC Hold/Preheat Current .
DC Stop	The motor is held with a DC current ([2-01] DC Brake Current) for a specified time ([2-02] DC Braking Time). <ul style="list-style-type: none"> DC Brake is activated in [2-03] DC Brake Cut In Speed [RPM] and a Stop command is active. DC Brake (inverse) is selected as a function for a digital input (parameter group [5-1]* Digital Inputs). The corresponding terminal is not active. The DC Brake is activated via serial communication.
Feedback high	The sum of all feedbacks is above the feedback limit set in [4-57] Warning Feedback High .
Feedback low	The sum of all actives is below the feedback limit set in [4-56] Warning Feedback Low .
Freeze output	The remote reference is active, which holds the present speed. <ul style="list-style-type: none"> Freeze output was selected as a function for a digital input (parameter group [5-1]* Digital Inputs). The corresponding terminal is active. Speed control is only possible via the terminal functions Speed Up and Speed Down. Hold ramp is activated via serial communication.
Freeze output request	A freeze output command has been given, but the motor will remain stopped until a run permissive signal is received.
Freeze Reference	<i>Freeze Reference</i> was chosen as a function for a digital input (parameter group [5-1]* Digital Inputs). This corresponding terminal is active. The controller saves the actual reference. Changing the reference is now only possible via terminal functions Speed Up and Speed Down.
Jog request	A jog command has been given, but the motor will be stopped until a run permissive signal is received via a digital input.
Jogging	The motor is running as programmed in [3-19] Jog Speed [RPM] . <ul style="list-style-type: none"> Jog was selected as function for a digital input (parameter group [5-1]* Digital Inputs). The corresponding terminal (e.g. Terminal 29) is active. The Jog Function is activated via the serial communication. The Jog function was selected as a reaction for a monitoring function (e.g. No signal). The monitoring function is active.

Motor check	In [1–80] Function at Stop, Motor Check was selected. A stop command is active. To ensure that a motor is connected to the controller, a permanent test current is applied to the motor.
OVC control	<i>Overvoltage</i> control was activated in [2–17] Over-voltage Control, [2] Enabled . The connected motor is supplying the controller with generative energy. The overvoltage control adjusts the V/Hz ratio to run the motor in controlled mode and to prevent the controller from tripping.
PowerUnit Off	(For controllers with an external 24 V power supply installed only.) Mains supply to the controller is removed, but the control card is supplied by the external 24 V.
Protection md	Protection mode is active. The unit has detected a critical status (an overcurrent or overvoltage). <ul style="list-style-type: none"> • To avoid tripping, switching frequency is reduced to 4 kHz. • If possible, protection mode ends after approximately 10 s • Protection mode can be restricted in [14–26] Trip Delay at Inverter Fault
QStop	The motor is decelerating using [3–81] Quick Stop Ramp Time . <ul style="list-style-type: none"> • <i>Quick stop inverse</i> was chosen as a function for a digital input (parameter group [5–1]* Digital Inputs). The corresponding terminal is not active. • The quick stop function was activated via serial communication.
Ramping	The motor is accelerating/decelerating using the active Ramp Up/Down. The reference, a limit value or a standstill is not yet reached.
Ref. high	The sum of all active references is above the reference limit set in [4–55] Warning Reference High .
Ref. low	The sum of all active references is below the reference limit set in [4–54] Warning Reference Low .
Run on ref.	The controller is running in the reference range. The feedback value matches the setpoint value.
Run request	A start command has been given, but the motor is stopped until a run permissive signal is received via digital input.
Running	The motor is driven by the controller.
Sleep mode	The energy saving function is enabled. This means that at present the motor has stopped, but that it will restart automatically when required.
Speed high	Motor speed is above the value set in [4–53] Warning Speed High .
Speed low	Motor speed below the value set in [4–52] Warning Speed Low .
Standby	In Auto On mode, the controller will start the motor with a start signal from a digital input or serial communication.
Start delay	In [1–71] Start Delay , a delay starting time was set. A start command is activated and the motor will start after the start delay time expires.

Start fwd/rev	Start forward and start reverse were selected as functions for two different digital inputs (parameter group [5-1]* Digital Inputs). The motor will start in forward or reverse depending on which corresponding terminal is activated.
Stop	The controller has received a stop command from the LCP, digital input or serial communication.
Trip	An alarm occurred and the motor is stopped. Once the cause of the alarm is cleared, the controller can be reset manually by pressing [Reset] or remotely by control terminals or serial communication.
Trip lock	An alarm occurred and the motor is stopped. Once the cause of the alarm is cleared, power must be cycled to the controller. The controller can then be reset manually by pressing [Reset] or remotely by control terminals or serial communication.

LCP parameters

The display configuration shown above represents the default settings. Items 2-6 can be adjusted to display other values. To display other values, modify parameters [0-20], [0-21], [0-22], [0-23] or [0-24] which correspond to 2, 3, 4, 5 and 6 respectively.

Menu keys



Table 12: Function description of menu keys

Key	Function
Status	<p>Pressing the [Status] key toggles between different status screens. There are three different status screens; five readouts (default), four line readouts or Smart Logic Control.</p> <ul style="list-style-type: none"> • Use the [Status] key for selecting the mode of the LCP or for changing back to Status Display mode from any other menu. • The LCP display contrast can also be adjusted by pressing [Status] plus [▲] or [▼] to adjust the display brightness. • The symbol in the upper right corner of the display shows the direction of motor rotation (arrow), which set-up is active (number) and which is being programmed (number in parenthesis).
Quick Menu	<p>Pressing the [Quick Menu] key provides access to a set of submenus that allows easy access to some common parameters as well as the Start-Up Genie. The Quick Menu consists of My Personal Menu, Quick Set-up, Function Set-up, Start-Up Genie, changes made and Loggings.</p>
Main Menu	<p>Pressing the [Main Menu] key allows access to the complete parameter set. Press [Main Menu] twice to access the top level index. Press [Main Menu] once to return to the last location accessed. Press and hold [Main Menu] for 5 seconds provides access to the Parameter Shortcut. The Parameter shortcut allows the user to enter a parameter number to give direct access to that parameter.</p>

Key	Function
Alarm Log	The [Alarm Log] key allows access to the 5 latest alarms numbers A1-A5. To obtain details about an alarm, use the arrow keys to highlight the alarm number and press OK.

Navigation keys

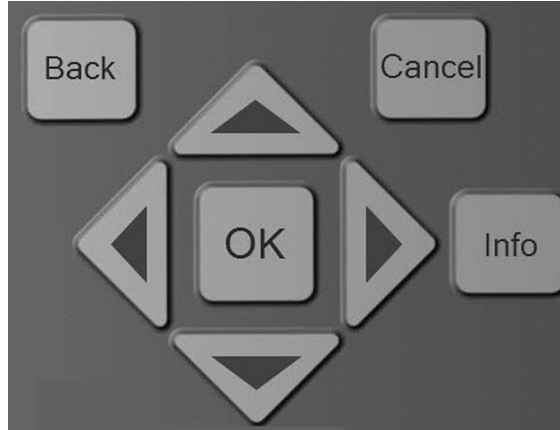

Table 13: Navigation keys functions

Key	Function
Back	Pressing the [Back] key reverts to the previous step or layer in the navigation structure.
Cancel	Pressing the [cancel] button will cancel the last change or command as long as the display has not been changed.
Info	Pressing the [Info] button will display information about a command, parameter, or function in any display window. [Info] provides detailed information when needed. Exit the Info mode by pressing either [Info], [Back], or [Cancel].
OK	[OK] is used for choosing a parameter marked by the cursor and for enabling the change of a parameter.
Arrows	The four navigation arrows are used to navigate between the different choices available in [Quick Menu], [Main Menu] and Alarm Log]. Use these keys to move the cursor.

Table 14: Indicator lights functions

Light	Indicator	Function
Green	ON	The ON light activates when the controller receives power from mains voltage, a DC bus terminal, or an external 24 V supply.
Yellow	WARN	When warning conditions are met, the yellow WARN light comes on and text appears in the display area identifying the problem.
Red	ALARM	A fault condition causes the red alarm light to flash and an alarm text is displayed/

Operation keys

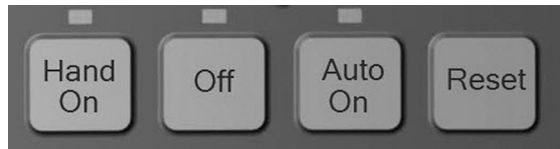

Table 15: Operation keys functions

Hand On	The [Hand On] key enables control of the drive via the LCP interface. Pressing [Hand On] also starts the motor and the speed can be manually adjusted using the arrow keys. The [Hand On] key can be enabled or disabled via parameter [0-40] [Hand on] Key on LCP . If [Hand On] is active the drive can be stopped by: <ul style="list-style-type: none"> • Start signal on DI 18 • The [Off] button • Stop command from serial communication
Off	Pressing the [Off] key will stop the motor. The [Off] key can be enabled or disabled via parameter [0-41] [Off] Key on LCP . If no external stop function is selected and the [Off] key is disabled, the motor can only be stopped by disconnecting the mains supply.
Auto On	Pressing the [Auto On] key enables the drive to be controlled via the control terminals and/or serial communication. When a start signal is applied on the control terminals and/or serial communication, the drive will start. This key can be enabled or disabled via [0-42] [Auto on] Key on LCP .
Reset	The [Reset] key is used for resetting the controller after an alarm (trip). The key can be enabled or disabled via parameter [0-43] [Reset] Key on LCP .

Status lights



If certain threshold values are exceeded, the alarm and/or Warning (Warn.) LED will turn on. If an alarm or warning is active, a status or alarm text will appear on the control panel.

- Yellow Warn. LED: Indicates a warning is active.
- Red Flashing Alarm LED: Indicates an alarm is active.

The On LED is activated when the controller receives power.

- Green On LED: Control section is powered and working.

Parameter backup

Parameter settings are stored internally in the controller. The parameters can be uploaded to the LCP for backup or to easily transfer the parameter settings from one controller to another controller. A factory reset/initialization does not change the data stored in the LCP.

NOTE: Parameter data can be uploaded to the LCP through the use of the Start-Up Genie. Simply select *Copy to LCP* from the setup selection menu at the beginning of the Genie.

To upload parameters to the LCP without the use of the Start-Up Genie follow the following procedure:

1. Press [Off] to stop the motor before uploading data.
2. Press [Main Menu] to enter the parameter list.
3. Select [0-**] **Operation / Display**, press [OK].
4. Use the down arrow to scroll to [0-5*] **Copy/Save**, press [OK] to enter the submenu.
5. Press [OK] to enable editing of parameter [0-50] **LCP Copy**.
6. Use the up or down arrows to scroll to ALL to Copy, press [OK] to select.
7. The progress bar will show the status of the process.
8. Press [Status] to return to the main status screen.
9. Press [Auto On] or [Hand On] to resume previous operating mode.

NOTE: Parameter data can be uploaded to the LCP through use of the Start-Up Genie. Simply select *Copy from LCP* from the setup selection menu at the beginning of the Genie. Select *All* to copy all parameters from the LCP including size dependent data. Select *Application Only* to copy all size independent data.

To download parameters to the controller from the LCP without use of the Start-Up Genie follow the procedure below.

1. Press [Off] to stop the motor before uploading data.
2. Press [Main Menu] to enter the parameter list.
3. Select [0-**] **Operation / Display**, press [OK].
4. Use the down arrow to scroll to [0-5*] **Copy/Save**, press [OK] to enter the submenu.
5. Press [OK] to enable editing of parameter [0-50] **LCP Copy**.
6. To copy all data from the LCP, including size dependent data, use the up or down arrows to scroll to *All from LCP*, press [OK] to select. To copy all size independent data, scroll to *Size indep. from LCP*, press [OK] to select.
7. The progress bar will show the status of the process.
8. Press [Status] to return to the main status screen.
9. Press [Auto On] or [Hand On] to resume previous operating mode.

Factory Reset/Initialization

A factory reset or an initialization can be performed to restore the controller back to default settings. There are multiple ways to perform this function.

Parameter [14-22] **Operation Mode** can be used to perform the factory reset function. Using this method does not change controller data such as operating hours, serial communication selections, fault log, alarm log, and other monitoring functions. To perform the reset through parameter 14-22 perform the following steps.

1. Press [Main Menu] to enter the parameter list.
2. Use the up and down arrows to scroll to [14-**] **Special Functions**, press [OK].
3. Use the up and down arrows to scroll to [14-2*] **Reset Functions**, press [OK].
4. Use the up and down arrows to scroll to [14-22] **Operation Mode**, press [OK].
5. Press [OK] to enable modification of the parameter.
6. Use the up and down arrows to scroll to *Initialization*, press [OK].
7. Remove input power from the unit and wait for the LCP to turn off.
8. Apply power to the unit. The reset is performed at power up.
9. *Alarm 80 Drive Initialized to Default Value* will be displayed.
10. Press [Reset] to return to operation mode.

Another way to perform the factory reset or initialization is to issue a 3 finger reset. The process is described below.

1. Remove power from the unit and wait for the LCP to turn off.
2. Press and hold [Status], [Main Menu], and [OK] at the same time. While holding down the buttons, apply power to the unit.

6 Mechanical Installation

6.1 Installation requirements

Cooling

- To provide cooling airflow, mount the unit to a solid flat surface or to the optional back plate.
- Top and bottom clearance for air cooling must be provided. Generally, 100-225 mm (4-10 in) is required.

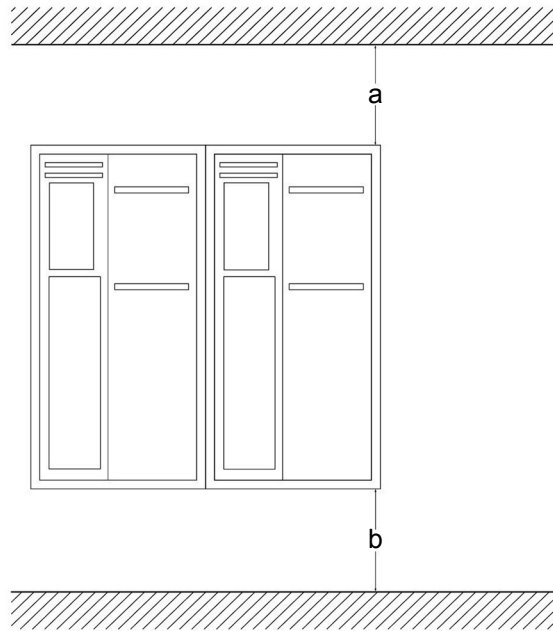

Enclosure	A2-A5	B1-B4	C1, C3	C2, C4
a/b	100 mm (3.9 in)	200 mm (7.9 in)	200 mm (7.9 in)	225 mm (8.9 in)

- Improper mounting can result in overheating and reduced performance.
- Derating for temperatures starting between 40°C (104°F) and 50°C (122°F) and elevation 1000 m (3300 ft) above sea level must be considered. See the Technical Bulletin for detailed information.

Lifting

- Check the weight of the unit to determine a safe lifting method.
- Ensure that the lifting device is suitable for the task.
- If necessary, plan for a hoist, crane, or forklift with the appropriate rating to move the unit.
- For lifting, use hoist rings on the unit, when provided.

Mounting

- Mount the unit vertically.
- The frequency converter allows side by side installation.
- Ensure that the strength of the mounting location will support the unit weight.
- Mount the unit to a solid flat surface or to the optional back plate to provide cooling airflow.

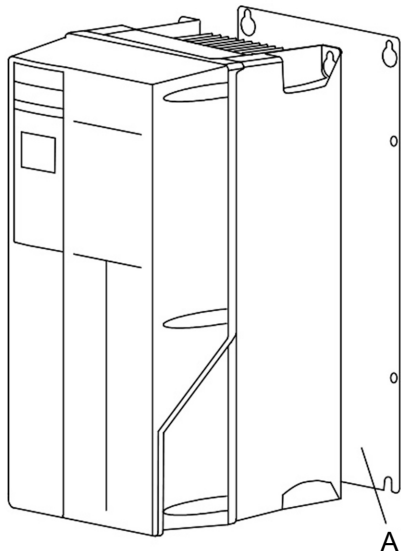

Figure 36: Mounting with back plate

Item	Description
A	Properly installed back plate

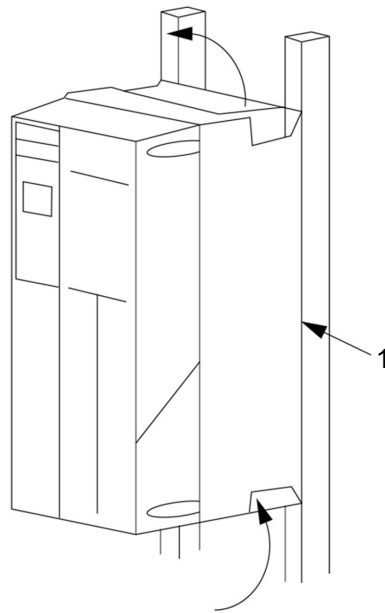

Figure 37: Mounting with railings

Item	Description
1	Back plate ¹

Tightening torques

See Technical Specification section for details.

¹ Back plate is needed when mounted on railings.

Piping connections

NOTICE:

All plumbing work must be performed by a qualified technician. Always follow all local, state and provincial codes.

A proper installation requires a pressure relief valve, a diaphragm tank, a 1/4" female NPT threaded fitting for the pressure sensor, and properly sized pipe. Piping should be no smaller than pump discharge and/or suction connections. Piping should be kept as short as possible. Avoid the use of unnecessary fittings to minimize friction losses.

**CAUTION:**

Use pipes suited to the maximum working pressure of the pump. Failure to do so can cause the system to rupture, with the risk of injury.

All joints must be airtight. Use Teflon tape or another type of pressure sealant to seal threaded connections. Please be careful when using thread sealant as any excess that gets inside the pipe may plug the pressure sensor.

Galvanized fittings or pipe should never be connected directly to the stainless steel discharge head or casing as galvanic corrosion may occur. Barb type connectors should always be double clamped.

**WARNING:**

Do not install any valves (except check valves), flow control devices or filters between the pressure transducer and the pump. It is allowable to run branches off the pipe between the pump and transducer as long as no flow restricting devices are between the pump and transducer.

Diaphragm tank, pressure relief valve and discharge piping

Use only "pre-charged" tanks on this system. Do not use galvanized tanks. Select an area that is always above 34°F (1.1°) in which to install the tank, pressure sensor and pressure relief valve. If this is an area where a water leak or pressure relief valve blow-off may damage property, connect a drain line to the pressure relief valve. Run the drain line from the pressure relief valve to a suitable drain or to an area where water will not damage property.

Diaphragm tank, system pressure

A diaphragm tank (not included) is used to cushion the pressure system during start-up and shut-down. It should be sized to at least 20% of the total capacity of your pump. For example: If your pump is sized for 100 GPM then size your tank for at least 20 gallon total volume, not draw down. Pre-charge your bladder tank to 15-20 PSI below your system pressure. The controller is pre-set for 50 PSI at the factory. Therefore a 30-35 PSI pre-charge in your tank would be required. Use the higher tank pre-charge setting if the system drifts over 5 PSI at a constant flow rate. **NOTE: Pre-charge your tank before filling with water.**

The maximum working pressure of the HydroPro diaphragm tank is 125 PSI.

**CAUTION:**

Exceeding the working pressure of the tank can cause the tank to rupture or explode.

Installing the pressure sensor

The pressure sensor requires a 1/4" FNPT fitting for installation. Install the pressure sensor with the electrical connector pointing up to avoid clogging the pressure port with debris. Install the pressure sensor in a straight run of pipe away from elbows or turbulence. For optimum pressure control install the pressure sensor in the same straight run of pipe as

the pressure tank. Ensure the pressure sensor is within 10 feet of the pressure tank. Installing the pressure sensor far away from the pressure tank may result in pressure oscillations. Do not install the pressure sensor in a location where freezing can occur. A frozen pipe can cause damage to the pressure sensor.

Underwater connection

When using submersible motors, a waterproof connection is required between the drop cable and motor leads. The underwater connection where the drop cable connects to the motor wires must be made using a waterproof heat shrink kit. To make the connection:

1. Strip the wires 1/2" and place the heat shrink tubes over the wires.
2. Connect the wires using the crimps.
3. Shrink the tubes over the crimps by heating from the center outward.
 - The sealant in the tube will flow over the ends making a watertight seal.
 - If a heat shrink tube is burnt or split, the connection will need to be remade.

Vinyl electrical tape is not acceptable for underwater splices when using variable speed drives. There is a high potential for leakage to ground through taped joints.



CAUTION:

Failure to use a waterproof heat shrink kit will void the warranty.

Before installing the motor in the well, the drop cable must be connected to the motor wires. Refer to the wire size chart when selecting wire size for the drop cable.

7 Operation

7.1 Pre-start procedure



Electrical Hazard:

If input and output connections have been connected improperly, there is potential for high voltage on these terminals. If power leads for multiple motors are improperly run in same conduit, there is potential for leakage current to charge capacitors within the frequency converter, even when disconnected from mains input. For initial start up, make no assumptions about power components. Follow pre-start procedures. Failure to follow pre-start procedures could result in personal injury or damage to equipment.

1. Make sure input power to unit is OFF and locked out. Do not rely on the frequency converter disconnect switches for input power isolation.
2. Verify that there is no voltage on input terminals L1 (91), L2 (92), and L3 (93), phase-to-phase and phase-to-ground.
3. Verify that there is no voltage on output terminals 96 (U), 97 (V), and 98 (W), phase-to-phase and phase-to-ground.
4. Confirm continuity of the motor by measuring ohm values on U-V (96-97), V-W (97-98), and W-U (98-96).
5. Check for proper grounding of the frequency converter as well as the motor.
6. Inspect the frequency converter for loose connections on terminals.
7. Record the following motor-nameplate data: power, voltage, frequency, full load current, and nominal speed. These values are needed to program motor nameplate data later.
8. Confirm that the supply voltage matches voltage of frequency converter and motor.

7.2 Pre-startup inspections

Item to Inspect	Description	Checked
Auxiliary equipment	<ul style="list-style-type: none"> • Look for auxiliary equipment, switches, disconnects, or input fuses/circuit breakers that may reside on input power side of the frequency converter or output side to motor. Ensure they are ready for full speed operation. • Check function and installation of any sensors used for feedback to the frequency converter. • Remove power factor correction caps on motor(s), if present. 	
Cable routing	<ul style="list-style-type: none"> • Ensure that input power, motor wiring and control wiring are separated or in three separate metallic conduits for high frequency noise isolation. 	
Control wiring	<ul style="list-style-type: none"> • Check for broken or damaged wires and connections. • Check that control wiring is isolated from power and motor wiring for noise immunity. • Check the voltage source of the signals, if necessary. • The use of shielded cable or twisted pair is recommended. Ensure that the shield is terminated correctly. 	
Cooling clearance	<ul style="list-style-type: none"> • Measure that top and bottom clearance is adequate to ensure proper air flow for cooling. 	
EMC considerations	<ul style="list-style-type: none"> • Check for proper installation with regard to electromagnetic capability. 	
Environmental conditions	<ul style="list-style-type: none"> • See equipment tech label for the maximum ambient operation temperature limits. • Humidity levels must be 5-95% non-condensing. 	
Fusing and circuit breakers	<ul style="list-style-type: none"> • Check for proper fusing or circuit breakers. • Check that all fuses are inserted firmly and in operational condition and that all circuit breakers are in the open position. 	

Item to Inspect	Description	Checked
Grounding (earthing)	<ul style="list-style-type: none"> The unit requires an earth wire (ground wire) from its chassis to the building ground (earth). Check for good earth connections (ground connections) that are tight and free of oxidation. grounding (earthing) to conduit or mounting the back panel to a metal surface is not a suitable ground (earth). 	
Input and output power wiring	<ul style="list-style-type: none"> Check for loose connections. Check that motor and mains are in separate conduit or separated screened cables. 	
Panel interior	<ul style="list-style-type: none"> Inspect that the unit interior is free of dirt, metal chips, moisture, and corrosion. 	
Switches	<ul style="list-style-type: none"> Ensure that all switch and disconnect settings are in the proper positions. 	
Vibration	<ul style="list-style-type: none"> Check that the unit is mounted solidly or that shock mounts are used, as necessary. Check for an unusual amount of vibration. 	

Checked by:

Date:

7.3 Apply power

NOTICE:

- HIGH VOLTAGE.** Frequency converters contain high voltage when connected to AC mains. Installation, start-up and maintenance should be performed by qualified personnel only. Failure to comply could result in death or serious injury.
- UNINTENDED START.** When the frequency converter is connected to AC mains, the motor may start at any time. The frequency converter, motor, and any driven equipment must be in operational readiness. Failure to comply could result in death, serious injury, equipment, or property damage.
- POTENTIAL HAZARD IN THE EVENT OF INTERNAL FAILURE!** Risk of personal injury when the frequency converter is not properly closed. Before applying power, ensure all safety covers are in place and securely fastened.

1. Confirm that the input voltage is balanced with 3%. If not, correct voltage imbalance before proceeding. Repeat this procedure after the voltage correction.
2. Ensure that optional equipment wiring, if present, matches the installation application.
3. Ensure that all operator and start enable devices are in the OFF position. Panel doors should be closed or cover mounted.
4. Apply power to the unit. **DO NOT** start the frequency converter at this time. For units with a disconnect switch, turn to the ON position to apply power to the frequency converter.

7.4 Discharge time



WARNING:

Disconnect and lock out electrical power and wait for the minimum waiting time specified below. Failure to wait the specified time after power has been removed before performing service or repair could result in death or serious injury.

Frequency converters contain DC-link capacitors that can remain charged even when the frequency converter is not powered. To avoid electrical hazards, disconnect:

- AC mains
- Any permanent magnet type motors
- Any remote DC-link power supplies, including battery backups, ups and DC-link connections to other frequency converters.

Wait for the capacitors to discharge completely before performing any service or repair work. Refer to the following table for wait times:

Voltage (V)	Power range (HP)	Minimum waiting time (min)
380-480	150-350	20
380-480	450-600	40
525-690	150-400	20
525-690	450-600	30

High voltage may be present even when the warning LED indicator lights are off.

7.5 Frequency converter programming

7.5.1 Programming the controller

The controller can be programmed by using either the Start-Up Genie, Quick Menu mode or the Main Menu mode. The Main Menu mode allows access to all parameters. To modify a parameter or make a selection in either the Start-Up Genie, Quick Menu mode or the Main Menu mode follow the procedure below:

- To enter the Quick Menu mode press [Quick Menu] or to enter the Main Menu press [Main Menu].

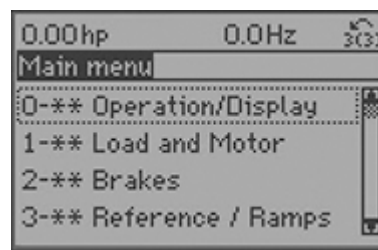
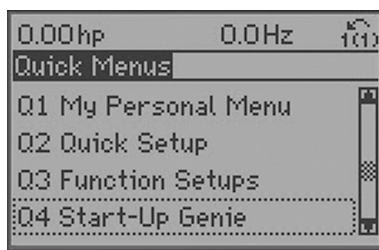

- The Start-Up Genie will begin automatically after the 1st power up or it can be rerun by selecting *Start-Up Genie* under *Quick Menus*.
- Select the desired selection in the Start-Up Genie, sub-menu in *Quick Menus* or parameter group in *Main Menu* by using the up and down arrows.
- Press [OK] to enter the sub-menu or selected parameter group.
- Once in the sub-menu or parameter group, use the up and down arrows to highlight the desired parameter. Press [OK] to select the parameter and enable editing.
- To edit the parameter use the up and down arrows to scroll through the parameter settings or selections. For numeric values with more than one digit, use the left and right keys to select the position within the number. The highlighted area can be modified by using the up and down arrows.
- Press [OK] to accept and save or [Cancel] to disregard the change.

Array parameters allow the modification of a group of parameters through one parameter address. An example of an array parameter is *5-40 Function Relay*. This parameter allows configuration of the 2 programmable relays included with the controller. To modify an array parameter follow the procedure below:

- Enter the Main Menu as previously described.
- Use the up and down arrows to scroll to *5-** Digital In/Out*. Press [OK] to enter the parameter group.
- Use the up and down arrows to scroll to *5-4* Relays*. Press [OK] to enter the parameter sub-group. The screen is shown below.

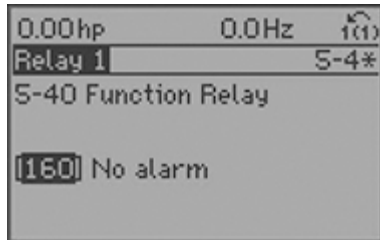
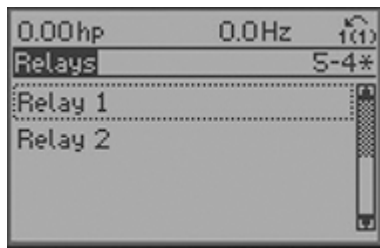

- To edit Relay 1, use the up and down arrows to highlight Relay 1 and press [OK] to select Relay 1.
- Press [OK] again to enable editing of Relay 1.
- Use the up and down arrows to select the desired relay function.
- Press [OK] to save the selection.
- Use the up and down arrows to select the 5-41 On Delay, Relay or 5-42 Off Delay, Relay. Repeat the steps above to edit these parameters.
- Press [BACK] to return to the Relays screen and repeat the above steps to edit the function for Relay 2.
- Press [Main Menu] to return to the Main Menu.

Quick menu

The Quick Menu mode contains various sub-menus that allow quick and easy access to common parameters. There are 6 sub-menus under Quick Menus. The 6 sub-menus are shown in the table below.

Table 16: Quick Menus

Sub-menu	Sub-menu Group Name	Description
Q1	My Personal Menu	Contains parameters commonly used to configure pump applications.
Q2	Quick Setup	Contains parameters commonly used to configure the controller.
Q3	Function Setups	Provides quick access to parameters commonly required for HVAC applications.
Q4	Start-Up Genie	Guides the user to configure the controller for various applications.
Q5	Changes Made	Shows the last 10 changed parameters, changes since factory defaults and input assignments.
Q6	Loggings	Displays graph line readouts of the LCP parameters. To change displayed LCP parameters use parameters 0-20 to 0-24.

My personal menu

My Personal Menu (Q1) has been configured at the factory to contain 20 parameters commonly used in pumping applications. Use My Personal Menu to change parameters while the system is running, such as changing Setpoint. The parameters found in My Personal Menu are shown below.

Parameter number	Parameter Name	Default Value	Parameter Description
20-21	Setpoint	50.0	Process setpoint. The controller will adjust speed to maintain this value. If multiple setpoints are enabled, this parameter will display and allow adjustment of the active setpoint.
22-44	Restart Difference (%)	10%	This is the difference between the setpoint and feedback that will cause the controller to restart from sleep mode. This is entered as a % of the setpoint. For a 50psi setpoint, a 10% Restart Difference will cause the controller to restart from sleep at 45psi.
4-12	Sleep Frequency/Low Limit[Hz]	30 Hz	This is the minimum speed of the motor and the speed at which the controller will enter sleep mode.
5-11	Terminal 19 Digital Input	No operation	This general purpose digital input is designated for the Pump Protect Function.
5-12	Terminal 27 Digital Input	No operation	This general purpose digital input is designated for the Pump Protect Function.
22-00	Pump Protect Delay	10 s	This is the time delay between detection of a Pump Protect condition and the triggering of the Pump Protect Alarm.
22-26	No Water/Loss of Prime Function	Man. Reset Alarm	This configures the No Water/Loss of Prime Function. Set this value to Man. Reset Alarm in order to utilize the No Water/Loss of Prime Restart Function.
22-39	No Water/Loss of Prime Limit	Size Dependent (HP)	This value sets the No Water/Loss of Prime limit. When the pump HP falls below this value while operating at maximum speed, the No Water/Loss of Prime Function will be implemented after the time specified in No Water/Loss of Prime Protection Delay [22-27].

Parameter number	Parameter Name	Default Value	Parameter Description
22-50	Under Pressure Function	Off	This parameter configures the Under Pressure Function. The Under Pressure Alarm/Warning is issued when the system pressure falls below the Under Pressure Limit [22-52] for longer than the Under Pressure Time Delay [22-51].
22-51	Under Pressure Delay Time	30 s	This parameter specifies the time between detection of an Under Pressure event and when the action defined in Under Pressure Function is issued.
22-52	Under Pressure Difference	10%	Under Pressure Difference is the difference between the setpoint and the actual pressure that will trigger the Under Pressure Function. This value is set as a % of Maximum Reference/Feedb. [20-14]
5-40	Function Relay	Relay 1: No Alarm Relay 2: Running	This parameter configures Relay 1 and 2 functions. This array parameter allows configuration of both relays. See Programming the controller for details on how to navigate the array parameter screen . [0] = Relay 1, [1] = Relay 2
5-41	On Delay, Relay	Relay 1: 0.01s Relay 2: 0.01s	This parameter configures Relay 1 and 2 On Delay Time. This array parameter allows configuration of both relays. See Programming the controller for details on how to navigate the array parameter screen . [0] = Relay 1, [1] = Relay 2
20-00	Feedback 1 Source	Analog Input 53	Feedback source for the PID controller, transducer input source.
20-13	Min Reference/Feedb.	0.0	Minimum feedback value for the transducer.
20-14	Max Reference/Feedb.	300.0	Maximum feedback value for the transducer.
3-41	Ramp 1 Ramp Up Time	10 s	Ramp up time (0 to full speed). Increasing this time will produce a slower ramp up.
3-42	Ramp 1 Ramp Down Time	5 s	Ramp down time (full speed to 0). Increasing this time will produce a slower ramp down.

Parameter number	Parameter Name	Default Value	Parameter Description
20-93	PID Prop Gain	5	Proportional correction gain for PID controller. Increasing this value will produce a faster system response. CAUTION: Increasing this value too high can make the system unstable and produce severe oscillations.
20-94	PID Integration Time	3.3 s	Integration time for the PID controller. Increasing this value will produce a slower system response. CAUTION: Decreasing this value too low can make the system unstable and produce severe oscillations.

Start-Up Genie

This controller is equipped with a Start-Up Genie which allows the user to easily configure the controller for various pump control applications. The Genie configures parameters that are based on the selections that are made by the user. The Genie allows the user to configure the Motor, Application type, inputs, outputs, pump protection features, flow compensation, and communications. The application types include Single Pump, Constant Slave, Duplex Control, Speed Control, and test run mode. See the Setup and Commissioning section for details.

Main menu

The parameters in the Main Menu are grouped by category. Note that some groups are not visible unless the appropriate option card is installed. The parameter groups in the Main Menu are shown below.

Parameter Group	Parameter Group Name
0	Operation/Display
1	Load and Motor
2	Brakes
3	Reference/Ramps
4	Limits/Warnings
5	Digital In/Out
6	Analog In/Out
8	Comm. and Options
9	Profibus*
10	CAN Fieldbus*
11	LonWorks*
13	Smart Logic
14	Special Functions
15	Drive Information
16	Data Readouts
18	Info & Readouts
20	Drive Closed Loop
21	Ext. Closed Loop
22	Appl. Functions

Parameter Group	Parameter Group Name
23	Time-based Functions
24	Appl. Functions 2
25	Cascade Controller
26	Analog I/O Option

* Appropriate option card must be installed.

Refer to the appendix for a complete parameter list.

7.5.2 Setup and commissioning

Start-Up Genie



CAUTION:

When a Start (Closed) signal is present on DI18, the controller can start the pump/motor at any time without warning. Set DI18 to Stop (Open) or press the [Off] operation key before using the Genie. Apply the Start signal to the controller only when pump/motor operation is desired.

The Start-Up Genie provides a fast and easy method for configuring the controller for various pump applications. The Navigation keys are used to make selections within the Genie. The [Info] button can be pressed at any time while in the Genie to retrieve additional information about the current screen or parameter.

To navigate through the Start-Up Genie, press [OK] to enable editing of a screen or parameter. Use the up and down arrows to highlight the desired selection then press [OK] to confirm the selection. Next use the down arrow to save the parameter and navigate to the next screen. The up arrow transitions to the previous screen. If the screen shows the desired setting is already selected for a particular parameter or function, simply use the down arrow to proceed to the next screen.

NOTE: Be sure to press the down arrow to save the parameter after confirming the selection. This ensures all associated parameter settings and background calculations are performed and saved properly. After pressing the down arrow to save the parameter the Genie may be slow to respond as these settings and calculations are performed.

Press [Cancel] to exit parameter editing without saving or to change a saved parameter or selection back to the previously saved while still in the current screen. Pressing [Back] will also exit parameter editing without saving. To exit the Start-Up Genie at any time, first exit parameter editing then press [Back] then [OK].

The arrows shown in the lower right hand corner of the LCP indicate the options for navigation. When an up arrow is displayed, pressing the up arrow will transition to the previous screen. When a down arrow is displayed, pressing the down arrow will transition to the next screen. When both an up and down arrow are displayed then pressing the up arrow will transition to the previous screen and pressing the down arrow will transition to the next screen.

NOTE: Ensure the controller is set to Stop (DI 18 Open) and is set to Setup 1 prior to running the Start-Up Genie. To place the controller in Setup 1, ensure DI 33 is Open and the controller is set to Lead for Duplex systems. To manually change the lead pump in a Duplex System press [OK] and the right arrow keys on the lead drive. In Duplex Systems ensure alternation does not occur while running the Start-Up Genie by pressing [Off] before entering the Start-Up Genie.

The Genie starts automatically the first time the controller has been powered in the field or if the Genie has not been used previously. The Genie can be started at any time by accessing the *Quick Menus* screen by pressing [Quick Menu] then using the up and down arrows to highlight *Q4 Start-Up Genie*. Press [OK] to enter the Genie.

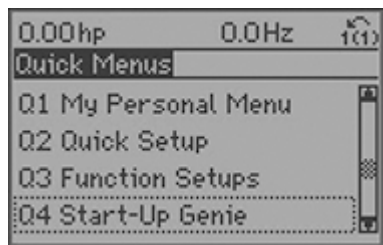

There are various screen types in the Start-Up Genie. One of these is the dual parameter screen.

To navigate the dual parameter screen use the up and down arrows to highlight the desired parameter. Press [OK] to enable editing of the highlighted parameter. Use the up and down arrows to set the parameter to the desired setting. Press [OK] to confirm the selection. To modify the other parameter shown, use the up and down arrows to highlight the other parameter and repeat the steps used to set and confirm the setting the previous parameter.

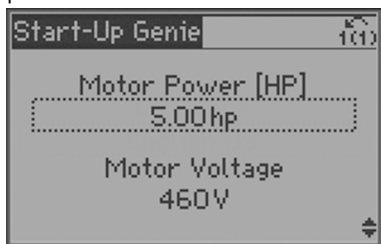

The array parameter screen allows configuration of a group of parameters configured as an array. For example the Relay Function screen shown below is an array parameter screen.

To navigate the array parameter screen press [OK] to enable editing of the array index. The array index is shown on the left side of the parameter value. Use the up and down arrows to select the desired index. Press [OK] to set the array index and enable editing of the parameter at the selected index. Use the up and down arrows to set the parameter to the desired setting. Press [OK] to confirm the selection.



Within the Start-Up Genie some screens will display "[unit]" after a parameter value. This nomenclature is used when a parameter is entered in the control units selected in the Start-Up Genie. For example, when entering the Setpoint for closed loop pressure control, the value could be entered in psi, bar, in HG, etc. In this case "[unit]" is used to account for this variation in units.

The first menu requires the user to set the language. To select a language, press [OK] to enable parameter editing. Use the up and down arrows to highlight the language then press [OK] to save the selection.



Next use the down arrow to proceed to the next section.

If this is the first time the Genie has run, the Genie will guide the user through the setup of the motor parameters. If the Genie has run previously, the user can choose the desired *Setup Selection* to configure a specific function in the controller. Use the up and down arrows to highlight the desired setup and press [OK] to enter the setup. The choices for the *Setup Selection* menu are described in the table below.



Table 17: Setups with the Genie

Setup	Description
Motor	This setup allows configuration of the motor parameters. These settings are found on the motor nameplate.
Application	The Application setup allows the user to configure the motor type, operating mode, units and ramps.
Feedback	This setup allows configuration of up to 3 feedback sources. The feedbacks can be taken in to the controller through analog inputs or communications.
Setpoint	This setup allows configuration of up to 2 setpoints. If multiple setpoints are used, the setpoint is selected by using DI 33.
Constant Slave	This setup configures the controller to operate up to 2 external fixed speed pumps using the 2 on board relays.
Flow Compensation	This setup configures the Flow Compensation function which can automatically adjust the system setpoint to offset the affect of friction loss in the system.
Pump Protection	This setup configures Sleep Mode, Flow Check, No Water/Loss of Prime and Pump Protect functions.
Digital Input	This setup allows configuration of the digital inputs.
Relay and Analog Output	This setup allows configuration of the relay and analog outputs.
Communication	This setup configures the on board fieldbus communications.
Copy to LCP	This setup allows all the controller parameters to be copied to the LCP. This is helpful for saving the drive state or to quickly configure another controller with the same settings.
Copy from LCP	This setup allows all the controller parameters to be copied from the LCP. This is helpful for reverting the drive to a previous state or to quickly configure another controller with the same settings.

Motor setup

The motor data required to complete the Motor Setup can be found on the motor nameplate. The Start-Up Genie will prompt the user for Motor Power (HP), Motor Nominal Voltage, Motor Nominal Frequency (Hz), Motor Nominal Speed (RPM), Motor Current (FLA), Current Limit (%) and Motor Type. Set the Current Limit as a percentage of the Motor Current (FLA). For example, if the Motor Current (FLA) indicated on the motor nameplate is 10A and the Motor Service Factor Current (SFA) is 11.5A, enter 115% for

Current Limit (%). Be sure to properly set the Motor Current (FLA) and Current Limit. These parameters will configure the motor overload protection feature.



The Motor Type menu allows selection of either a Submersible or Surface motor. This selection will configure specific settings to properly operate the chosen motor type.

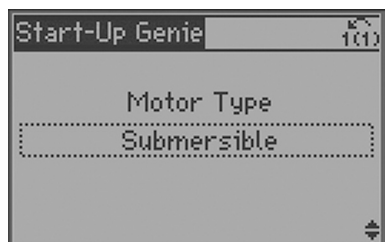

- If a Submersible motor is selected, the controller is configured to have a 30Hz minimum speed (parameter Sleep Frequency/Low Limit [4-12] = 30Hz), ramp from stop to 30Hz in 1 second (parameters 1-78 = 29Hz and 3-82 = 1 s) and to coast to stop (parameters 1-80 = Coast, 1-82 = 10Hz).
- If a Surface motor is selected, set the minimum speed (default parameter Sleep Frequency/Low Limit [4-12] = 30Hz), the stop ramp will be controlled by the default deceleration ramps (parameters 3-42 and 3-52) and to coast to stop (parameters 1-80 = Coast, 1-82 = 10Hz).

NOTE: There are various parameters that are linked to the motor parameter settings. Changing the motor parameter settings will also change the settings of these linked parameters. It is recommended to set the motor parameters first to avoid overwriting any settings made in the Start-Up Genie.

Application setup

The next menu set is the Application Setup which will allow selection and configuration of the application type and control response. Select the application type by first selecting the Operating Mode. Selecting the Operating Mode will configure specific parameters to configure the selected mode. If the Operating Mode is changed, any changes made to configure the previously configured Operating Mode will be overwritten. The Operating Mode can be set to Single Pump, Constant Slave, Duplex Control, Speed Control or Test Run Mode. The various Operating Modes are defined below.

Table 18: Operating modes

Operating Mode	Description
Single Pump	This mode is the default Operating Mode. Use this mode for constant pressure, flow or level applications that use 1 controller operating a single pump.
Constant Slave	This mode allows control of up to 2 external fixed speed pumps using the 2 on board relays. This mode can be used to extend the capacity of a system by staging fixed speed pumps as the demand in the system increases. Pumps can then be destaged as the system demand decreases.

Operating Mode	Description
Duplex Control	This mode configures the controller as part of a 2 controller, 2 pump system. Both pumps will run at the same varying speed. The staging and destaging of pumps can be configured to create a lead/lag system. The lead pump can be alternated based on elapsed time.
Speed Control	This mode configures the controller to accept a speed command through an analog input, pulse input or extended PI loop [21-**]. A start signal on DI 18 [5-10] is required.
Test Run Mode	Test Run Mode allows the controller to be configured to run the pump at specified speed for a specified amount of time. The action will be started by a digital input (DI 19).

Single pump

The Single Pump Operating Mode is the default operating mode for the controller. Use this mode for constant pressure, flow or level applications that use 1 controller operating a single pump.

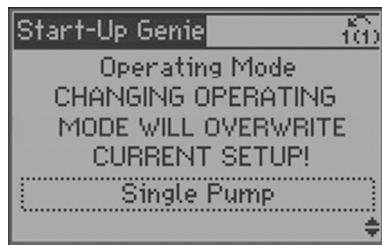

- The Application Type allows selection of the type of control. Select either Constant Pressure, Flow Control or Level Control.
- Next select the appropriate units for the application. These units will be displayed on the LCP default status screen.

If Level Control is the Application Type, select whether the application is a Tank Fill or Tank Empty application.



- In a 'Fill' application the pump will speed up when the level in the tank drops below the setpoint level.
- In an 'Empty' application the pump will speed up when the level in the tank is above setpoint level.
- The *PID Normal/Inverse Control* [20-81] parameter is set to *Inverse* for the 'Empty' application and to *Normal* for the 'Fill' application.

The ramp times are selected next. Select from either a Fast, Medium or Slow ramp.

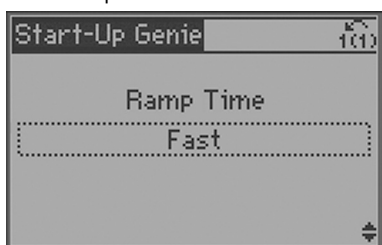

- A Fast ramp setting will have a 5 second acceleration ramp time and an 8 second deceleration time.
- A Medium ramp setting will have a 10 second acceleration ramp time and a 10 second deceleration time.
- A Slow ramp setting will have a 20 second acceleration ramp time and a 15 second deceleration time.
- Acceleration ramps are set in Parameters [3-41] and [3-51]. Deceleration ramps are set in Parameters [3-42] and [3-52].

The next screen will allow the user to automatically configure the rest of the parameters to default settings. The only parameter that must be set after selecting [Yes] is the setpoint. After the setpoint is configured the setup of the controller is complete. The default configurations are described in the table below. Note that [unit] will reflect the control units selected previously. If No is selected the Genie will prompt to proceed to the Feedback Setup.

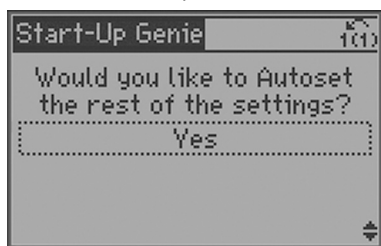
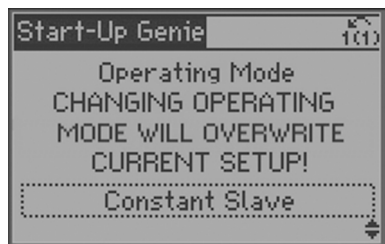

Table 19: Autoset configuration

Autoset Configuration	Constant Pressure	Level Control	Flow Control
Transducer Max Feedback	300 [unit]	300 [unit]	300 [unit]
Transducer Type	4-20mA	4-20mA	4-20mA
Feedback 1 Source	AI 53	AI 53	AI 53
PID Performance	Normal	Fill (Normal)	Normal
Sleep Mode	Enabled	Enabled	Disabled
Sleep Frequency	30 Hz	30 Hz	NA
Restart Difference	5 [unit]	5 [unit]	NA
No Water/Loss of Prime Fault	Enabled	Enabled	Enabled
No Water/Loss of Prime Restart Time	10 min.	10 min.	10 min.

Constant Slave

The Constant Slave Operating Mode allows control of up to 2 external fixed speed pumps using the 2 on board relays. This mode can be used to extend the capacity of a system by staging fixed speed pumps as the demand in the system increases. Pumps can then be destaged as the system demand decreases. The variable speed pump is always the lead pump. The fixed speed pumps can be staged and destaged to create a lead/lag system.



The Application Type can be set to either Constant Pressure or Level Control. Set control variable units and ramps as described in Single Pump Operating Mode.

The next menu prompts the user to set the number of pumps in the system. Enter the number of pumps in the system, including the variable speed pump. The selection will be entered in to parameter [25-06] *Number of pumps*. If 2 pumps are selected, this means that there is 1 variable speed pump and 1 fixed speed pump in the system. The fixed speed pump will be controlled by relay 1.

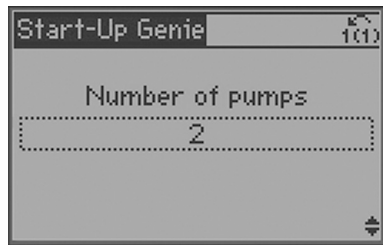

The next menu prompts the user to enable or disable *Run Time Equalization* [25-04]. When the parameter is disabled the pumps will always be turned on (stage) in the order of pump 1 then pump 2 and turned off (destage) in the order of pump 2 then pump 1. Enabling this parameter will stage and destage the fixed speed pumps to provide equal run time for each fixed speed pump.

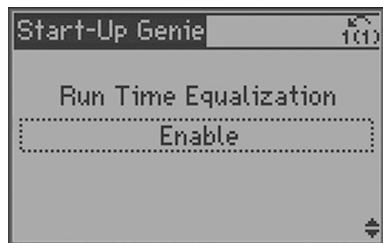

The next menu configures the [25-20] *Staging Bandwidth*. The Staging Bandwidth (SBW) sets a range around the setpoint in which no staging or destaging of pumps will occur. This range is set to avoid frequent staging and destaging of pumps and to accommodate normal fluctuations present in the system. The Staging Bandwidth (SBW) is set as a percentage of the setpoint. For example if a setpoint of 50 psi is selected, and the SBW is set to 10% then no staging or destaging of pumps will occur in the range of 45-55 psi.



The next menu configures the staging delay times. These delay times define the length of time that the system pressure must be outside the SBW before staging or destaging pumps will occur. For example if the [25-23] *SBW Staging Delay* is set to 10 seconds and the system pressure is outside the SBW for more than 10 seconds a fixed pump will be staged. If the pressure transitions back inside the SBW before the delay time expires, the timer will reset. Parameter [25-24] *SBW Destaging Delay* sets the delay time associated with pumps being destaged.

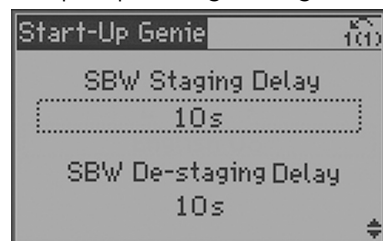

Duplex control

The Duplex Control Mode configures the controller for operation in a system with 2 controllers and 2 variable speed pumps. Each controller is connected to a single pump. When configured as a lead/lag system (Duty Standby Disabled) the pumps can be staged or destaged as the demand requires. When both pumps run at the same time they will operate at the same speed. The lead controller/pump can be switched/alternated between the 2 controllers.

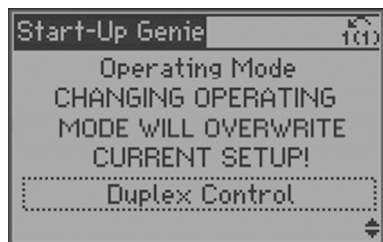

NOTE: The Duplex Control Mode requires specific control wiring for proper operation. Consult the **Wiring to Control Terminals** section in this manual for details.

NOTE: The Duplex Control Mode requires specific parameter settings to proper operation. Changing to Duplex Control will overwrite any preconfigured parameters.

As in the previously described application types, the control units and ramp times are configured first. The next screen allows the user to automatically configure the rest of the parameters to default settings. The only parameter that must be set after selecting Yes is the setpoint. After the setpoint is configured the setup of the controller is complete. The default configurations are described in the table below.

Table 20: Duplex Autoset Configuration

Duplex Autoset Configuration	
Transducer Max. Feedback	300 [unit]
Transducer Type	4-20mA
Feedback 1 Source	AI 53
Sleep Frequency	30 Hz
Restart Difference	5 [unit]
No Water/Loss of Prime Fault	Enabled
Duty Standby	Disabled
Lag Start Freq	59 Hz
Lag Stop Freq	35 Hz
Alternation	Enabled
Alternate Time	24 Hrs
Pump Exercise Time	0 s (Disabled)

Duty standby

Enabling Duty Standby allows the system to be configured as a 2 pump redundant system. With Duty Standby enabled both pumps will not run at the same time during normal operation. Only the lead pump will run when required.

The pumps can be configured to alternate the lead pump by enabling Alternation. Disabling Duty Standby configures the 2 pump system as a lead/lag system. With Duty Standby disabled, the pumps can be staged/destaged as required based on system demand.

NOTE: If *Duty Standby* is enabled, both pumps may run at the same time during alternation, after a start command is received or after an alarm is reset depending on the setting of *Start Delay* [1-71]. Set the *Start Delay* [1-71] longer than the *Ramp Down Time* [3-42] of the other pump or 3 seconds, whichever is longer, to avoid this condition. Refer

to *Pump Exercise* for details on how Duty Standby, Pump Exercise and Start Delay impact when pumps are expected to run.



Lag pump start frequency and lag pump stop frequency

The *Lag Pump Start Frequency* and *Lag Pump Stop Frequency* can be configured to control the frequency/speed that the lag pump is staged and destaged. This feature is enabled only when Duty Standby is Disabled. The *Lag Pump Start Frequency* (staging frequency) should be set to a frequency close to the maximum speed of the motor/pump. The default is set to 59Hz with a maximum speed of 60Hz. This will ensure best utilization of each pump. The *Lag Pump Stop Frequency* (destaging frequency) should be set to a frequency above the [4-12] *Sleep Frequency/Low Limit [Hz]* of the lead pump. For example, when the [4-12] *Sleep Frequency/Low Limit [Hz]* is set to 30Hz, the Lag Pump Stop Frequency should be set to 35Hz. The actual value used depends on system requirements.

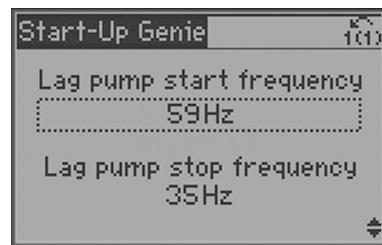

Alternation and alternation time

Enabling *Alternation* allows the lag pump to become the lead after the *Alternation Time* expires. Enabling *Alternation* allows equalization of loading between the 2 pumps and controllers. The *Alternation Time* is based on elapsed time, not pump run time. Because of this it is recommended to set *Alternation Time* to a time that is greater than or equal to 24 hours. For example, in a system that has high demand in the morning, setting the Alternation Time to 24 hours ensures each pump will be the lead pump every other morning which will equalize the loading between the two pumps.



Note: The lead pump can be manually alternated by pressing the [OK] and right arrow keys on the lead drive.

Pump exercise

The Pump Exercise Function forces the lead pump to run for a specified time during lead/lag pump alternation. This function is designed to help prevent the effects that can occur on a pump as a result of remaining idle for long periods of time. Set the Pump Exercise Time to the amount of time the new lead pump will run during alternation. For example, if the Pump Exercise Time is set to 10 seconds, the new lead pump will run for 10 seconds when the lead and lag pumps alternate. Set Pump Exercise Time to 0s to disable the function.

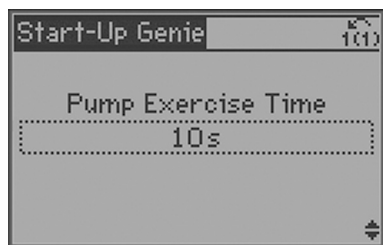

NOTE: If Pump Exercise is enabled, the pump will run after alternation of the lead pump even if there is no demand in the system.

NOTE: If Duty Standby is enabled, Pump Exercise cannot be disabled. Refer to the table below for details.

The settings for Duty Standby, Pump Exercise and Start Delay can impact when a pump is expected to start. The table below shows how these settings impact when a pump will start.

Duty Standby	Pump Exercise	Explanation
Disabled	Disabled	If both controls are given a start command at the same time or both controls are reset from a fault at the same time, both pumps will run until the lead pump and lag pump roles are established. With both functions disabled, the duplex system will operate as a lead/lag system. On Alternation, the new lead pump will not run unless there is demand in the system.
Disabled	Enabled	<p>The lag pump will start when the lead pump wakes up from sleep or if the lead pump is stopped and is then given a start command. For these conditions the lag pump will run for the time specified in <i>Pump Exercise Time</i> [22-40]. The lag will continue to run if the speed command from the lead pump is greater than the <i>Lag Pump Stop Frequency</i> [4-12].</p> <p>On Alternation, the new lead pump will run for the time specified in Pump Exercise Time. After the Pump Exercise Time, the pump will continue to run if demand is present or will go to sleep if there is no demand.</p>
Enabled	Enabled	<p>On Alternation and no demand, the new lead pump will start and run for the time specified by <i>Pump Exercise Time</i> [22-40] or <i>Sleep Delay</i> [22-24], whichever is longer. The pump will then go to sleep, if enabled.</p> <p>On Alternation with demand, the new lead pump will ramp up while the previous lead pump is ramping down. In order to ensure both pumps do not run at the same time in this condition, set the <i>Start Delay</i> [1-71] time longer than the <i>Ramp Down Time</i> [3-42].</p>

Start delay

The Start Delay Function delays the lead pump from starting for the time specified. This function can be used to prevent rapid cycling of the system or to prevent the new lead pump from starting up while the lag pump is ramping down during alternation. For example, if the Start Delay Time is set to 10 seconds and the pump is given a start command, the pump will start 10 seconds after the command to start is received by the controller. In a Duplex System with the Start Delay set to 10 seconds, if Alternation is enabled and the Alternation Time expires the new lead pump will start after a 10 second delay. If Duty Standby is enabled, set the Start Delay longer than the *Ramp Down Time* [3-42] of the other pump to ensure both pumps do not run at the same time.



Speed control

Speed Control Mode allows the speed to be controlled by an external device such as a PLC or BMS. A start signal on DI 18 is required to start and stop the pump.

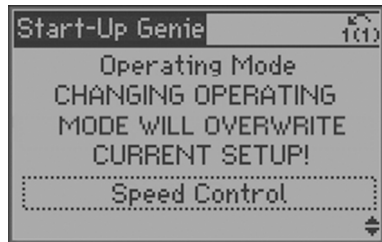

To configure Speed Control Mode first select the speed reference source. Select the speed reference source as either an analog input or, if using the fieldbus as the speed reference source, select No Function. When using the analog inputs be sure to set the analog input configuration switches to the appropriate feedback type. Refer to the Analog Input Configuration (Switches A53 and A54) section for details on setting the analog input configuration switches. Refer to the Common Terminal Wiring Configurations section in this manual for detail on wiring external devices to the analog inputs.

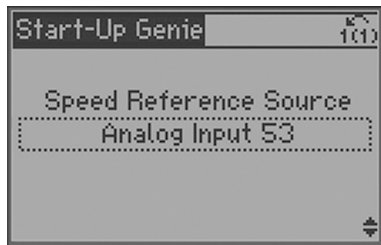

Next set the minimum and maximum reference/feedback values. The *Low Ref./Feedb. Value* is the speed value that corresponds with the low current (0 or 4mA for current references) or low voltage (0V for voltage references) that will be applied to the analog input. The *High Ref./Feedb. Value* is the speed value that corresponds with the high current (20mA for current references) or high voltage (10V for voltage references) that will be applied to the analog input. For example, if the application uses a 4-20mA reference signal on AI 53 and the pump is required to operate from 30Hz to 60Hz, set [6-14] Terminal 53 Low Ref./Feedb. Value to 30 and [6-15] Terminal 53 High Ref./Feedb. Value to 60.

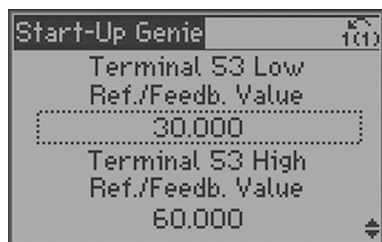

The minimum and maximum speed reference values are set next. These values are the minimum and maximum speed settings for the application. These settings will limit the controllable speed range of the pump. The speed range will be limited to the *Minimum Speed Reference* as the low speed limit and *Maximum Speed Reference* as the high speed

limit. Using the example above, set the *Minimum Speed Reference* to 30Hz and the *Maximum Speed Reference* to 60Hz.

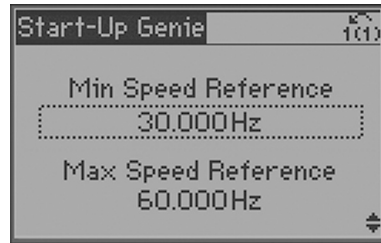

Test Run Mode

Test Run Mode allows the controller to perform a test which will ramp the pump at a specified speed in order to perform a test on the system and pump/motor. Test Run Mode is triggered to start based on the state of DI 18. When DI 18 is closed, the test will begin. When DI 18 is open, test run mode will stop. To configure Test Run Mode set the test run speed and test run ramp time. The Test Run Speed is the speed that the controller will ramp the pump to. The Test Run Ramp Time is the ramp used to reach the Test Run Speed. This ramp is the time to ramp from stop (0 RPM) and the rated motor speed. The Test Run Ramp Time applies to both acceleration and deceleration in Test Run Mode.



Feedback setup

The controller can utilize up to 3 feedback sources using the onboard IO. 2 of these sources can be configured for the analog inputs (AI 53 and AI 54). The third can be set to bus feedback which can be set through the onboard fieldbus communications.

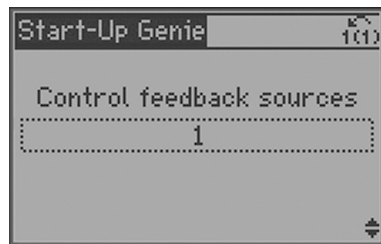

When using analog inputs be sure to set the analog input configuration switches to the appropriate feedback type. Refer to the Analog Input Configuration (Switches A53 and A54) section for details on setting the analog input configuration switches. Refer to the Common Terminal Wiring Configurations section in this manual for detail on wiring external devices to the analog inputs.

If multiple feedback sources are selected then the *Feedback Function [20-20]* can be configured. The Feedback Function determines how the multiple feedbacks will be used to control the system.



Feedback function [20-20]	
Sum	The sum of all feedbacks will be in the feedback to the controller.
Difference	The difference between Feedback 1 and Feedback 2 will be the feedback to the controller. This setting is commonly used to configure a differential pressure signal using 2 separate transducers. NOTE This selection is only valid with Feedback 1 and Feedback 2. Feedback 3 is not used with this selection.
Average	The average of all feedback will be the feedback to the controller.
Minimum	The lowest feedback will be the feedback to the controller.
Maximum	The highest feedback will be the feedback to the controller.

The minimum and maximum values for each feedback source must be configured to properly scale the input. For example, for a 0-300 psi transducer, set the Low Feedback Value to 0 psi and the High Feedback Value to 300 psi.

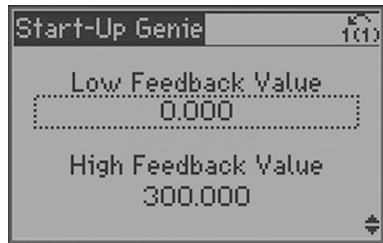

A Sensor Fault can be enabled or disabled for each feedback. If the Sensor Fault is enabled and the input to the feedback source falls below 2mA for 4-20mA signals, the Sensor Fault is issued. The Sensor Fault will automatically restart according to [14-20] *Reset Mode* and [14-21] *Automatic Restart Time*. The defaults for these parameters are set for an Automatic reset x 3 and an Automatic Restart Time of 10 seconds. For example, with the default settings if a Sensor Fault is issued the controller will attempt to reset every 10 seconds. The controller will make 3 attempts to reset the fault. If the fault is not cleared in this time the controller will require a manual reset.

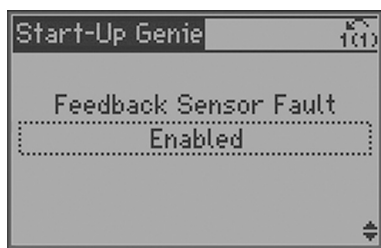

Setpoint Setup

The controller can be configured to switch between 2 different setpoints. The setpoints will be selected through digital input 33 (DI 33, parameter 5-15). When parameter 5-15 is set to *Set-up Select Bit 0* and DI 33 is open, the controller will use SP1 (*Setpoint 1 [20-21] Setup 1*) as the target pressure, flow or level for the system. When parameter 5-15 is set to *Set-up Select Bit 0* and DI 33 is closed (connected to 24V), the controller will use SP2 (*Setpoint 1 [20-21] Setup 2*) as the target pressure, flow or level for the system.



Flow Compensation Setup

As flow in a pumping system increases, the system friction head losses also increase. Friction head loss is higher in systems with increased pipe lengths or decreased pipe size. The impact of this head loss is that the pressure at different points in the system will vary depending on flow rate and the distance from the pump. The loss will be most significant in the zones farthest from the pump. The controller's internal Flow Compensation function is used to correct the effect of friction head loss in the system. The flow compensation function calculates a control curve based on pump and system parameters. The controller actively adjusts the setpoint along the control curve based on the speed of the pump. Since a change in speed is proportional to a change in flow, the controller effectively adjusts the setpoint based on a change in speed. A change in pressure varies with the square of the change in speed or flow so a quadratic (square) compensation factor is used to adjust the setpoint. Parameter [22-81] *Square-linear Curve Approximation* can be modified to adjust the control curve between a linear (0%) and quadratic (100%). Note that 100% quadratic is the ideal compensation curve. The diagram below illustrates this concept. The rating curve is the pump performance curve at rated speed. The design curve is the system curve at design speed.

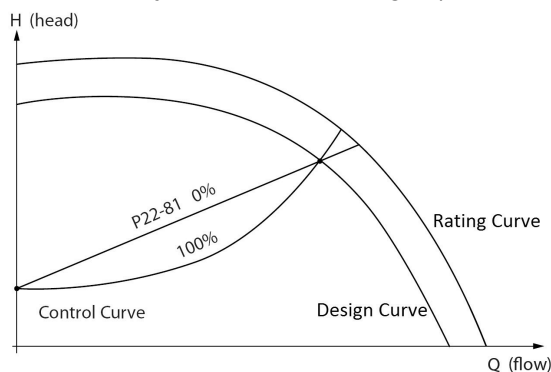

Figure 38: Flow compensation control curve

The flow compensation function requires some system parameters to be set in the controller to accurately model the control curve. Parameters must be set based on the design of the system in order to properly configure this function. The parameters that are required to be configured will depend on whether the speed at the design point is known. If the speed at the design point is known, set [22-82] *Work Point Calculation* to disabled. Set the [22-84] *Speed at No Flow [Hz]* and [22-87] *Pressure at No-Flow Speed*, which correlate to point A on the diagram below. The intersection of the system [20-21] *Setpoint* and [22-86] *Speed at Design Point [Hz]* correlates with point B. With this information the controller can then calculate the control curve. Refer to the diagram below.

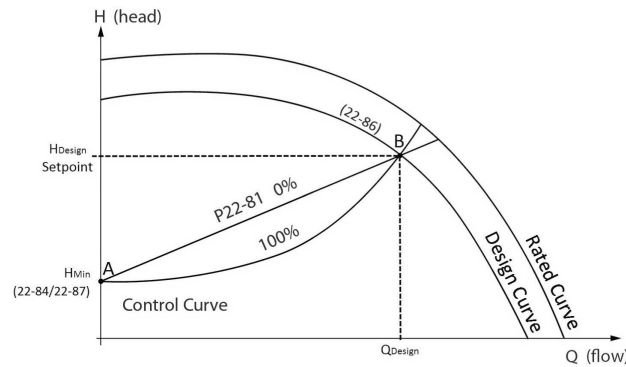

Figure 39: Flow compensation when speed at system design working point is known

Table 21: Flow compensation parameters when speed at design point is known

Parameter Number	Description	Set to
22-80	Flow Compensation	Enabled
22-81	Square-Linear Curve Approximation	Modify between 100% (square) and 0% (linear) per system requirements.
22-82	Work Point Calculation	Disabled – speed at the design point is known
22-84	Speed at No Flow [Hz]	To find this point, close all of the discharge valves in the system and briefly run the pump at the minimum design head. The speed corresponding to the minimum head requirement at no flow will be entered here.
22-86	Speed at Design Point [Hz]	These setpoints correspond to the speed required to maintain point B (design head $\{[20-21] \text{ Setpoint}\}$ and design flow)
22-87	Pressure at No Flow	System pressure at no flow and no flow speed. This is the minimum design head.

If the speed at the design point is unknown, the $[22-82]$ *Work Point Calculation* must be enabled. With the $[22-82]$ *Work Point Calculation* enabled the controller will calculate the speed at the design point based on settings of some additional parameters correlating to the points shown on the diagram below. The first point determined is point A which is the minimum required head at minimum speed ($[22-84]$ *Speed at No Flow [Hz]* and $[22-87]$ *Pressure at No-Flow Speed*). Points C and D can be determined by consulting the pump performance curve. Point C is determined by extending the design $[20-21]$ *Setpoint* line horizontally to intersect the rated curve which is the pump performance curve at rated speed (usually 50 or 60Hz). The flow at this point (Q_{Rated}) is set in $[22-90]$ *Flow at Rated Speed*. Point D is determined by extending the design flow point (Q_{Design}) vertically to intersect the rated speed curve. The head generated at this flow and speed is set at $[22-88]$ *Pressure at Rated Speed*. Knowing points A, C and D allow the controller to calculate point E along with the control curve which includes point B (speed, pressure and flow at design speed). Refer to the diagram below.

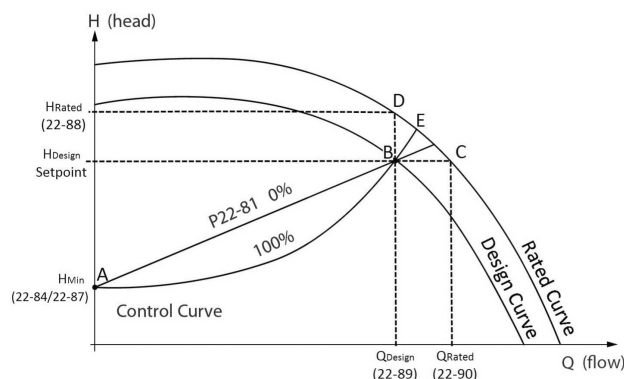

Figure 40: Flow compensation when speed at design working point is unknown

Table 22: Flow compensation parameters when speed at design point is unknown

Parameter Number	Description	Set to
22-80	Flow Compensation	Enabled
22-81	Square-Linear Curve Approximation	Modify between 100% (square) and 0% (linear) per system requirements.
22-82	Work Point Calculation	Enabled – speed at design point is unknown
22-84	Speed at No Flow [Hz]	To find this point, close all valves in the system and run the pump at the minimum head. The speed corresponding to the minimum head requirement at no flow will be entered here. Point A.
22-87	Pressure at No Flow	System pressure at no flow and no flow speed. This is the minimum design head. Point A.
22-88	Pressure at Rated Speed	This setting corresponds to the head developed at design flow and rated speed. This value can be defined using the pump performance curve. Intersects with the design flow to form point D.
22-89	Flow at Design Point	This setting corresponds to the system design flow. Intersects with the pressure at rated speed to form point D and with the setpoint to form point B.
22-90	Flow at Rated Speed	This setting corresponds to the flow at rated speed. This value can be defined using the pump performance curve. Intersects with the setpoint to form point C.

Dual Pump Value Increase

In a Duplex Control System the friction losses can increase when both the lead and lag pumps are running due to the additional flow in the system. When both pumps are running, the Rated Curve and Design Curve shown above will change (reach higher flows at a given pressure) when compared to when a single pump is running. This means that the settings given to configure the Flow Compensation function may not be accurate when both pumps are running. The *Dual Pump Value Increase* setting applies an increase to the setpoint which will offset the additional losses associated with both pumps running.

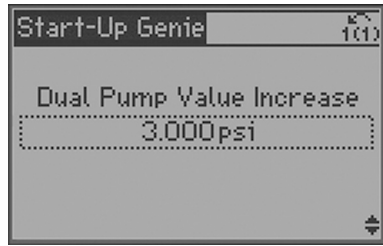

NOTE: This function is not intended for substitution of proper pipe layout and sizing according to Hydraulic Institute Standards.

7.5.3 Pump protection setup

Sleep mode

Sleep Mode protects the pump by turning off the pump in cases where there is no flow in the system. Sleep mode can be enabled or disabled. If Sleep Mode is disabled the pump will not turn off during a no flow condition if no other control devices are present to turn the pump off. The *Sleep Frequency/Low Limit [4-12]* and *Sleep Delay [22-24]* are set first. The *Sleep Frequency/Low Limit [4-12]* is the frequency that the pump has to reach or fall below in order to enter sleep mode. The Sleep Frequency is also the minimum frequency. The Sleep Delay is the amount of time the pump speed must be at or below the Sleep Frequency in order to enter Sleep Mode. Use this parameter to prevent the pump from entering sleep mode too soon.



The *Restart Difference [22-44]* is the difference between the setpoint and the actual value that will cause the pump to restart (wake up) from sleep mode. This value is entered as a percent of the setpoint. For example, if the setpoint is 50 psi and a 10% Restart Difference is entered the pump will restart from sleep mode after the system pressure drops 5 psi below the set pressure (45 psi). If multiple setpoints are used then a Restart Difference must be entered for each setpoint.



The *Minimum Run Time [22-40]* and *Minimum Sleep Time [22-41]* can be used to prevent rapid cycling. The *Minimum Run Time [22-40]* forces the pump to stay on and not enter sleep mode until the pump runs for the time entered in *Minimum Run Time [22-40]*. The *Minimum Sleep Time [22-41]* forces the pump to stay in sleep mode (turned off) for the time entered in *Minimum Sleep Time [22-41]*.



The *Setpoint Boost [22-45]* function can be used to further reduce cycle time. The Setpoint Boost function increases the system pressure before the pump enters sleep mode. To configure this function, exit the Genie and enter the parameter list by pressing the [Main Menu] key. Set parameter [22-45] *Setpoint Boost* and [22-46] *Maximum Boost Time*. *Setpoint Boost [22-45]* is the amount of increase in system pressure desired before the pump enters sleep mode. This is entered as a percent of setpoint. The Maximum Boost Time is a timeout function used to ensure the pump enters sleep mode. If the pump cannot achieve the setpoint + Setpoint Boost pressure before the Maximum Boost Time expires, the pump will enter sleep mode.

Flow check

The Flow Check function performs a test to determine whether flow or demand exists in the system. If a no flow condition exists in the system the pump will ramp down to Sleep Frequency and enter sleep mode. The Flow Check function is performed only when the pump is running. A diagram showing the Flow Check function is shown below. Motor speed is shown to illustrate the pump reaction to the Flow Check function. As shown in the diagram, when demand (flow) stops, the Flow Check function forces the system pressure to be higher than the Pressure Setpoint which forces the pump to enter sleep mode.

NOTE: This function is not available in Duplex Control mode.

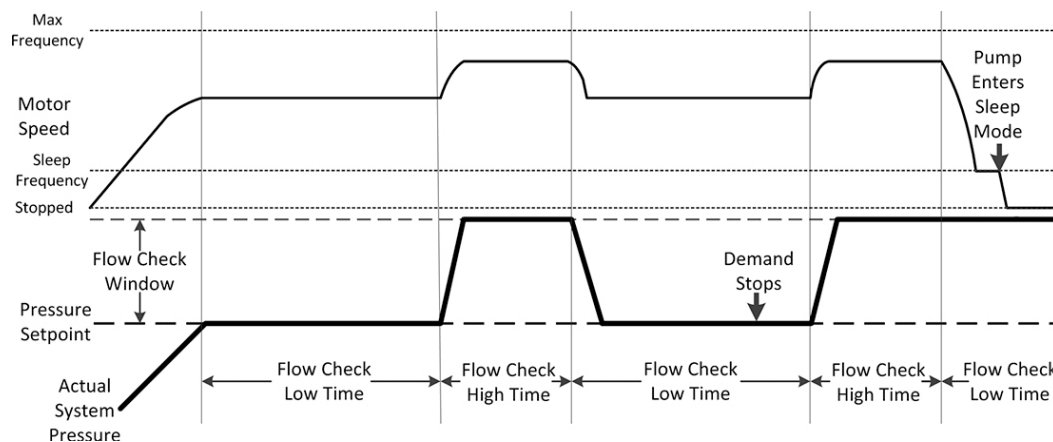
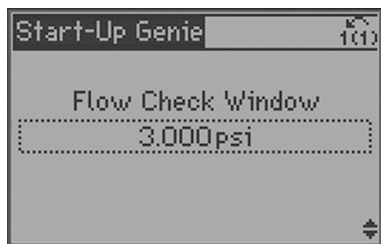

To configure the Flow Check function first set the Flow Check Window. The Flow Check Window is the amount of pressure increase that will be used during the Flow Check function test. This amount is added to the existing setpoint to create a new temporary setpoint. Next set the Flow Check Low Time and the Flow Check High Time. The Flow Check Low Time defines how long the controller will run at the setpoint before applying the value set in Flow Check Window. The Flow Check High Time defines how long the controller will run at setpoint plus the value set in Flow Check Window. These times are

limited between 10 and 300 seconds. Ensure Flow Check Low Time is set long enough to allow the pump to ramp down to the sleep frequency. Setting the Flow Check Low Time longer or equal to the *Ramp Down Time* [3-42] will ensure the pump has time to ramp to sleep during the Flow Check Low Time.

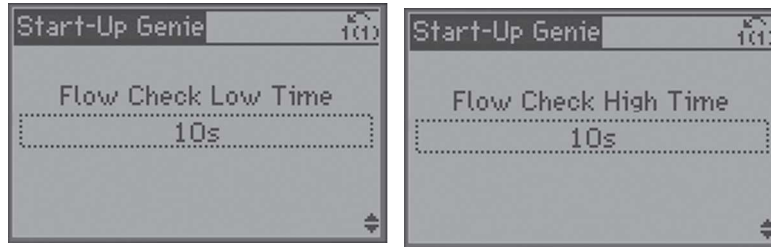

No Flow Power Calibration

A no flow condition can also be detected by monitoring the power consumption of the pump. Typically a pump's power consumption will drop when the pump is run at no flow. The graph shown below illustrates a typical pump power curve at the pump design flow and at no flow.

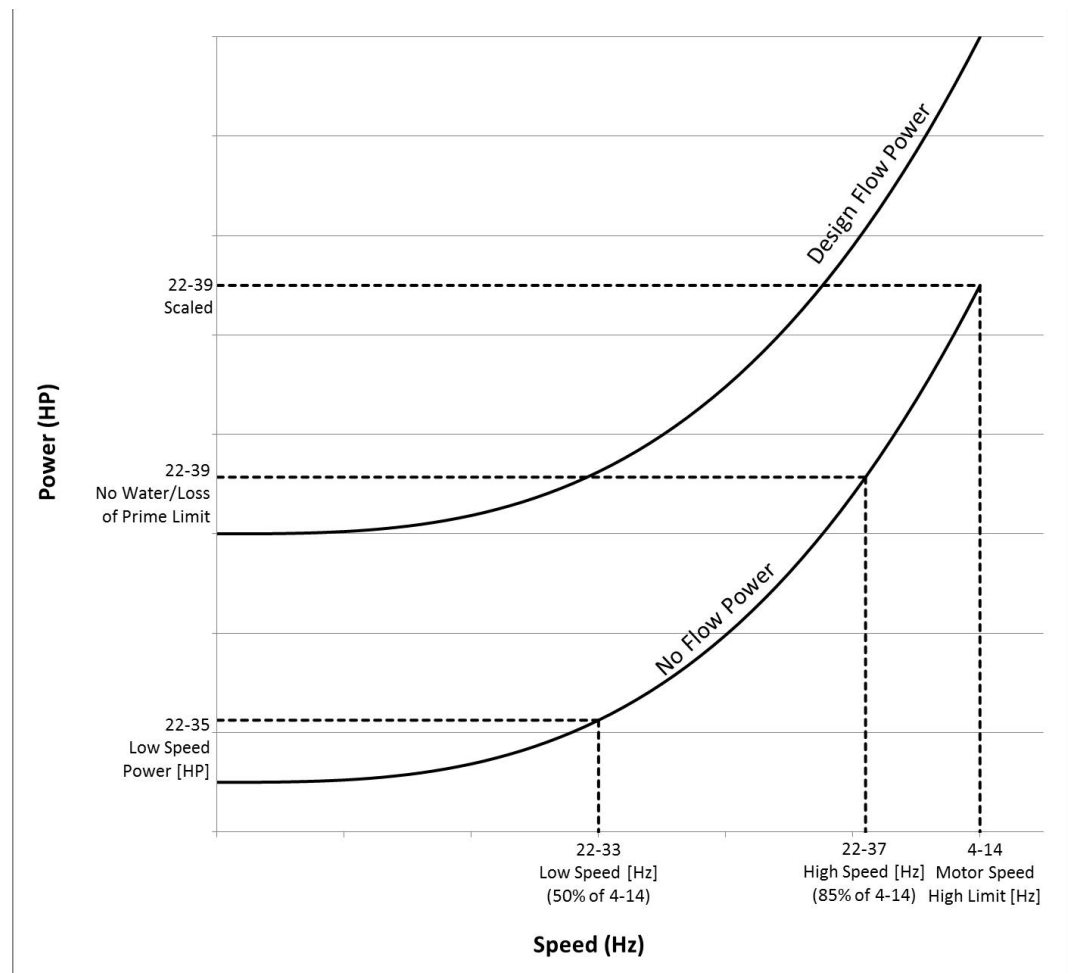

When the pump is operated at no flow, the power consumption will follow the no flow power curve for that specific pump. The controller monitors the power consumption of the pump. If the pump's power consumption falls to the no flow power curve, a no flow condition can be detected by the controller. In order to detect a no flow condition for various pumps, the no flow power curve needs to be programmed in to the drive. The No Flow Power Calibration Setup provides the method to program the no flow power curve in to the controller.

NOTE: Before beginning the No Flow Power Calibration Process ensure the *Sleep Frequency/Low Limit [4-12]* and the *Motor Speed High Limit [Hz] [4-14]* are set. These parameters are set as part of the Motor Setup.

NOTE: For the most accurate No-Flow Power Calibration data, run the setup after the system has reached normal operating temperature.



WARNING:

The No Flow Power Calibration Process requires the pump to be operated at no flow. This can produce high pressure within the system. Ensure the system piping and components are designed to withstand the suction pressure plus shutoff head pressure produced by the pump prior to starting the calibration process.

Select Enabled to begin the No Flow Power Calibration Setup.

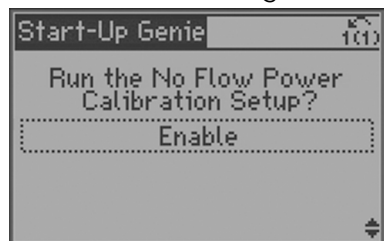

The first screen prompts to ensure the *Sleep Frequency/Low Limit [4-12]* and *Motor Speed High Limit [4-14]* have been set. If these points are not set the No Flow Power Calibration will not operate properly.

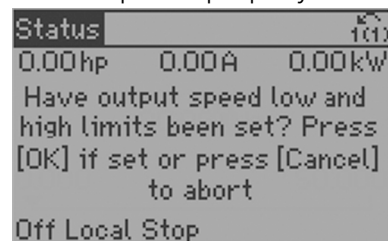

The next screen prompts to close all discharge valves and to press [Hand On] to begin the No Flow Power Calibration process. Doing this ensures the pump will operate at no flow/shutoff. If the pump does not operate at no flow during the setup, the calibration data will be invalid.

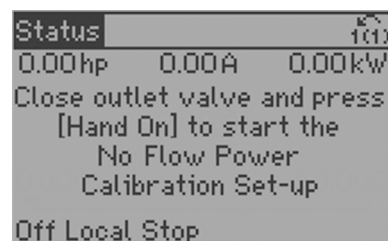

The controller will now begin running the pump while monitoring the power. In the first two steps the pump is operated at 85% of maximum speed defined at *Motor Speed High Limit [Hz] [4-14]* and the power to the pump is monitored and saved. The pump then operates at 50% of maximum speed and the power is monitored and saved. The no flow power curve is then constructed within the controller based on these 2 points using the affinity laws.

The No Flow Power Calibration Set-up is now complete. The power data can be saved by pressing [OK] and then the down arrow. If any issues were encountered during the calibration process discard the data by pressing [Cancel] and repeat the calibration process.

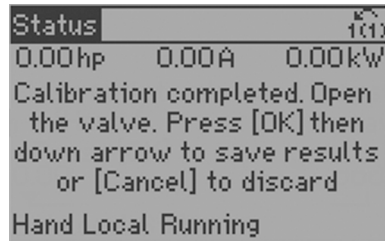

NOTE: Be sure to press [OK] then the down arrow to save the No Flow Power Calibration data. Pressing the down arrow ensures that all background calculations and parameter settings are performed properly.

NOTE: The No Flow Power Calibration Set-up configures the *No Water/Loss of Prime Limit [22-39]*. Do not modify the No Water/Loss of Prime Limit after the No Flow Power Calibration Set-up is completed. Modification of the *No Water/Loss of Prime Limit [22-39]* can cause the No Flow detection and No Water/Loss of Prime detection to malfunction.

In some cases the power calculation based on the calibration data taken during the No Flow Power Calibration Set-up may require adjustment. The *Power Correction Factor [22-31]* parameter allows the calculated power to be adjusted to avoid detection of a no flow condition while there is flow or to allow detection of a no flow condition while there is no flow in the system. If a no flow condition is detected while there is flow, the setting should be decreased. If a no flow condition is not detected while there is no flow, the setting should be increased above 100%.

No water/loss of prime

The No Water/Loss of Prime function is used to protect the pump against running dry and/or loss of prime. The function works by monitoring power at full speed and comparing the actual power to a preset limit. If the actual power falls below this preset limit for a specified amount of time, the No Water/Loss of Prime alarm is issued. If the No Water/Loss of Prime function is disabled, the pump will not be protected against running dry and/or loss of prime.

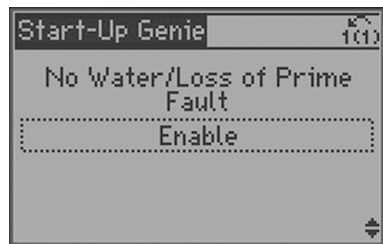

NOTE: In Duplex Control the No Water/Loss of Prime function is disabled by default on the lag pump. In Duplex Systems where pumps are fed from different sources the lag pump should be protected by using the Pump Protect Function. Refer to the Pump Protect Function for details.

NOTE: In Duplex Systems where pumps are fed from different sources and the lag pump is able to maintain the system pressure without reaching maximum speed, the No Water/Loss of Prime condition may not be detected on the lead pump. In this case it is recommended to delay the starting of the lag pump by setting the *Minimum Sleep Time [22-41]* on the lag pump greater than the *No Water/Loss of Prime Protection Delay [22-27]* plus the *Ramp Up Time [3-41]* of the lead pump. Be sure to set this on both controllers while set to lag if alternation is enabled.

The *No Water/Loss of Prime Limit [22-39]* is the no flow power value that corresponds to the speed entered in *High Speed [Hz] [22-37]*. The No Flow Power Calibration Set-up automatically enters 85% of the *Motor Speed High Limit [Hz] [4-14]* in *High Speed [Hz] [22-37]*.

The No Water/Loss of Prime function works by monitoring the pump power consumption at full speed, and the *No Water/Loss of Prime Limit [22-39]* corresponds the pump power consumption at 85% of full speed. The controller internally scales the *No Water/Loss of*

Prime Limit [22-39] based on the affinity laws to determine the actual power limit for the No Water/Loss of Prime function. Since pump power consumption changes with the cube of speed and the No Water/Loss of Prime Limit is entered as 85% of maximum speed, the controller scales the power entered in *No Water/Loss of Prime Limit [22-39]* by $(1/85\%)^3$ or 1.628 to determine the actual power limit used for the No Water/Loss of Prime function.

When the pump is running at full speed and the actual power consumed by the pump is less than or equal to this value for a specified amount of time, the No Water/Loss of Prime alarm is issued. It is recommended to set this value by performing the No-Flow Power Calibration Setup.

NOTE: If the Autoset function is used to configure the controller this value is set to 75% of the service factor HP multiplied by the 85% speed ratio cubed (or $(85\%)^3 = 0.614$) of the pump/motor combination. For example, for a 10HP pump/motor with a pump/motor service factor of 1.15 (the pump utilizes 100% of the service factor of the motor), the Autoset function sets the No Water/Loss of Prime Limit [22-39] to 5.29HP.

The *Power Correction Factor [22-31]* can be used to modify the internal scaling of the *No Water/Loss of Prime Limit [22-39]* in cases where nuisance tripping results or where a No Water/Loss of Prime condition is not detected. If nuisance tripping results, the *Power Correction Factor [22-31]* can be increased above 100%. Increasing the *Power Correction Factor [22-31]* will increase the scaling of the *No Water/Loss of Prime Limit [22-39]* so that a No Water/Loss of Prime condition is detected at a higher power. The amount of increase above 100% is dependent on the loading of the pump. If a No Water/Loss of Prime alarm is not issued when the pump has lost prime or runs dry the *Power Correction Factor [22-31]* can be decreased so that a No Water/Loss of Prime condition is detected at a lower power. The amount of decrease below 100% is dependent on the loading of the pump.

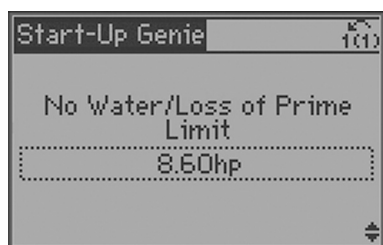

The No Water/Loss of Prime Restart function can be set to allow the controller to attempt to restart the pump after a specified amount of time. In order to enable this function a jumper wire must be installed between terminals 29 and 32. Refer to the *Common terminal wiring configurations* section in this manual for details on control terminal wiring. The default restart time is 10 minutes. Set this value based on the system requirements.



The *No Water/Loss of Prime Protection Delay [22-27]* is the time delay between detection of the No Water/Loss of Prime condition and the action of the No Water/Loss of Prime Alarm. The *No Water/Loss of Prime Protection Delay [22-27]* time can be extended to avoid nuisance tripping. Note that extending the time will allow the pump to run dry or without prime for the time specified.

NOTE: It is recommended to set the *No Water/Loss of Prime Protection Delay [22-27]* time shorter than the *Under Pressure Delay Time [22-51]*. This ensures a No Water/Loss of Prime condition will be detected properly before the Under Pressure function is triggered.

Under pressure function

The Under Pressure Function protects the pump and system by preventing the pump from running below a specified low pressure for a specified amount of time. This function can protect the pump from damage caused by running at runout flow and/or can protect the system from unexpected leakage such as from an open valve or ruptured pipe. Set the function to Alarm to trip the drive and issue an alarm message on the LCP during an Under Pressure condition. Set the function to Warning to issue a warning message on the LCP during an Under Pressure condition. Set the function to Off to disable the function.

NOTE: The Under Pressure Alarm will reset according to *Reset Mode [14-20]* and *Automatic Restart Time [14-21]*.



To configure this function the *Under Pressure Delay Time [22-51]* and *Under Pressure Difference [22-52]* must be set. The *Under Pressure Delay Time [22-51]* is the amount of time that the system pressure must be below the *Under Pressure Difference [22-52]* before issuing the Under Pressure alarm or warning.

NOTE: Setting the *Under Pressure Delay Time [22-51]* less than the *No Water/Loss of Prime Protection Delay [22-27]* will cause the Under Pressure Alarm to trip before the No Water/Loss of Prime Alarm in cases where the pressure drop in the system is due to the pump running dry or losing prime. To avoid this set the *Under Pressure Delay Time [22-51]* longer than the *No Water/Loss of Prime Protection Delay [22-27]*.

The *Under Pressure Difference [22-52]* is the difference between the setpoint pressure the actual pressure that will trigger the Under Pressure function. This pressure is set as a percent of the *[20-14] Maximum Reference/Feedback*. For example, the *Under Pressure Delay Time [22-51]* is set to 10 seconds, the *Under Pressure Difference [22-52]* is set to 10%, the pressure setpoint is set to 50 psi and the *[20-14] Maximum Reference/Feedback* is set to 300 psi. If the system pressure falls below 20 psi ($50 \text{ psi} - (10\% * 300 \text{ psi})$) for more than 10 seconds, the controller will issue an Under Pressure Alarm or Warning.

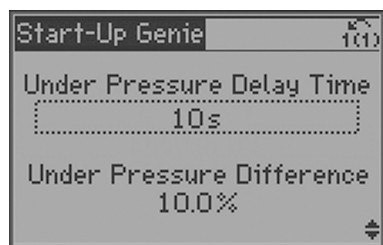

Pump protect function

The Pump Protect Function provides a way to stop the pump based on the state of an external protection device. The external device must be wired to DI 19 (parameter 5-11) or DI 27 (parameter 5-12), refer to the Common Terminal Wiring section in this manual for details. One side of the external device must be wired to 24V (terminals 12 or 13) and the other is wired to the digital input (terminal 19 for digital input 19 or terminal 27 for digital input 27). Refer to the *Common terminal wiring configurations* section in this manual for details on control terminal wiring.

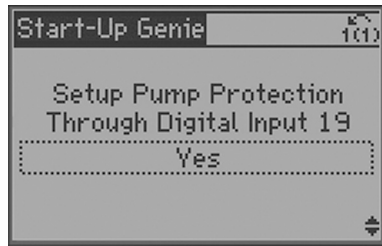

NOTE: Only connect external devices with non-powered contacts to the digital inputs.

NOTE: Only DI 19 is available for the Pump Protect Function in Duplex Control.

The *Pump Protect Delay [22-00]* time can be configured to prevent false or nuisance tripping or the Pump Protect warning or alarm. When Pump Protect is enabled and the corresponding digital input is open for more than the time indicated in *Pump Protect Delay [22-00]*, the Pump Protect warning or alarm is issued. The same delay time is used for Pump Protect on DI 19 and DI 27.



The Pump Protect alarm will reset according to *Reset Mode [14-20]* and *Automatic Restart Time [14-21]*.

7.5.4 Digital input setup

Any unused digital input can be configured as part of the Digital Input Setup. A list of the digital inputs and their associated functions are shown below. The default function of a digital input can change based on the Operating Mode selected. Digital Input 18 is utilized as a Start function for all operating modes. This input has a dedicated function and cannot be configured in the Digital Input Setup. A separate table is given for the Duplex Control mode due to the specific functionality assigned to the digital inputs.

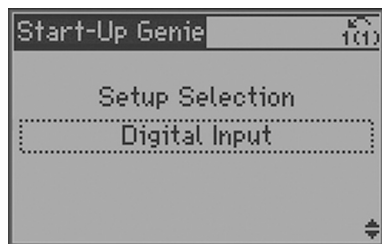

NOTICE:

Changing the function of any assigned digital input or output when set to Duplex Control Mode will cause the controller to malfunction.

Table 23: Digital input functionality based on operating mode

Digital I/O		Operating Mode			Description
Terminal Number	Parameter Number	Single Pump/ Constant Slave	Speed Control	Test Run Mode	
18	5-10	[8] Start	[8] Start	[14] Jog	Start/Stop digital input signal for the drive. Connect input to 24 V to start. Open the input to stop. This is a required connection. In Test Run Mode, this input starts the test run.
19	5-11	[0] No Operation	[0] No Operation	[0] No Operation	Unused digital input. This input can be configured for use as a Pump Protect Warning or Alarm Input. See Pump Protect section to enable the Warning or Alarm associated with the input.
27	5-12	[0] No Operation	[0] No Operation	[0] No Operation	Unused digital input for all models. This input can be configured for use as a Pump Protect Warning or Alarm input. See Pump Protect section to enable the Warning or Alarm associated with this input.
29	5-13/5-31	[63] Comparator 3	[0] No Operation	[0] No Operation	Selectable for digital input or output. Default configuration is an output that is configured for use as a No Water/ Loss of Prime Restart signal in the Single Pump and Constant Slave mode. Refer to the Pump Protection section for details.

Digital I/O		Operating Mode			
Terminal Number	Parameter Number	Single Pump/ Constant Slave	Speed Control	Test Run Mode	Description
32	5-14	[1] Restart	[0] No Operation	[0] No Operation	Configured for use as a Reset for the No Water/Loss of Prime Restart function for Single Pump and Constant Slave modes. Refer to the Pump Protection section for details.
33	5-15	[23] SP1/SP2 Select	[23] SP1/SP2 Select	[23] SP1/SP2 Select	Digital input. Configured for use as a Setpoint 1/Setpoint 2 select (SP1/SP2)
20	–	Common	Common	Common	Common for digital inputs and reference for 24 V supply

Table 24: Digital input functionality based for duplex mode

Digital I/O		Duplex Control Mode		
Terminal Number	Parameter Number	Lead	Lag	Description
18	5-10	[8] Start	[8] Start	Start/Stop digital input signal for the drive. Connect input to 24 V to start. Open the input to stop. This is a required connection.
19	5-11	[0] No Operation	[0] No Operation	Unused digital input. This input can be configured for use as a Pump Protect Warning or Alarm input. See Pump Protect section to enable the Warning or Alarm associated with this input.

Digital I/O		Duplex Control Mode		
Terminal Number	Parameter Number	Lead	Lag	Description
27	5-12	Setpoint increase	Pump Exercise Input	When operating as the lead pump, this input will increase the setpoint when both pumps are on to compensate for the additional flow of the lag pump. This effectively performs a flow compensation function. When operating as a lag pump, this input acts as the Pump Exercise Input which will perform the Pump Exercise function. See Duplex Control in the Commissioning section of this manual for details.
29	5-13/5-31	I am Lead	I am Lead Inverse	Terminal 29 is configured as an output. This output is used to indicate which controller is the lead pump and which is the lag pump.
32	5-14	Slave Select	Slave Select	When this input is high, the other controller is operating as the lead pump. When high, this input will force the controller to become the lag pump or enter sleep mode if Duty Standby is enabled.
33	5-15	[23] SP1/SP2 Select	[23] SP1/SP2 Select	Digital input. Configured for use as a Setpoint 1/Setpoint 2 select (SP1/SP2). Open = SP1, Closed = SP2.
20	-	Common	Common	supply

7.5.5 Relay and Analog Output Setup

The Relay and Analog Output Setup allows configuration of the onboard relays and analog output signal.



NOTE: If Constant Slave Mode is enabled the relays are used to control the fixed speed pumps. Changing the relay function with Constant Slave Mode enabled can cause the Constant Slave Controller to malfunction.

Relay Outputs

To configure the relay set the relay function and the relay on delay. The relay function configures when the relay will change state. For example, when set to 'No Alarm', the relay will change state from the inactive to the active state when no alarms exist in the system. In the inactive state COM = NC and in the active state COM = NO. The relay on delay time is the time between the relay function trigger and when the relay changes state. For example, if the relay function is set to 'Running' and the delay time is set to 10 seconds, the relay will change state 10 seconds after the pump starts running. Relay 1 function is programmed as array parameter 5-40.0. Relay 2 function is programmed as part of array parameter 5-40.1. Relay 1 On Delay is programmed as part of array parameter 5-41.0. Relay 2 On Delay is programmed as part of array parameter 5-41.1.



The Relay Function screen is an array parameter screen. Refer to Programming the Controller section for details on how to program an array parameter screen.

The relay function options are shown in the table below.

Option	Function
[0]*	No operation
[1]	Control ready
[2]	Drive ready
[3]	Drive rdy/rem ctrl
[4]	Standby / no warning
[5]*	Running (Relay 2 Default)
[6]	Running / no warning
[8]	Run on ref/no warn
[9]	Alarm
[10]	Alarm or warning
[11]	At torque limit
[12]	Out of current range
[13]	Below current, low
[14]	Above current, high
[15]	Out of speed range
[16]	Below speed, low
[17]	Above speed, high
[18]	Out of feedb. range
[19]	Below feedback, low
[20]	Above feedback, high
[21]	Thermal warning
[25]	Reverse
[26]	Bus OK

Option	Function
[27]	Torque limit & stop
[28]	Brake, no brake war
[29]	Brake ready, no fault
[30]	Brake fault (IGBT)
[35]	Pump Protect
[36]	Control word bit 11
[37]	Control word bit 12
[40]	Out of ref range
[41]	Below reference, low
[42]	Above ref, high
[45]	Bus ctrl.
[46]	Bus ctrl, 1 if timeout
[47]	Bus ctrl, 0 if timeout
[60]	Comparator 0
[61]	Comparator 1
[62]	Comparator 2
[63]	Comparator 3
[64]	Comparator 4
[65]	Comparator 5
[70]	Logic rule 0
[71]	Logic rule 1
[72]	Logic rule 2
[73]	Logic rule 3
[74]	Logic rule 4
[75]	Logic rule 5
[80]	SL digital output A
[81]	SL digital output B
[82]	SL digital output C
[83]	SL digital output D
[84]	SL digital output E
[85]	SL digital output F
[160]*	No alarm (Relay 1 Default)
[161]	Running reverse
[165]	Local ref active
[166]	Remote ref active
[167]	Start command act.
[168]	Hand / Off
[169]	Auto mode
[180]	Clock Fault
[181]	Prev. Maintenance
[189]	External Fan Control
[190]	No Flow
[191]	No Water/Loss of Prime
[192]	Under Pressure

Option	Function
[193]	Sleep Mode
[194]	Broken Belt
[195]	Bypass Valve Control
[196]	Fire Mode
[197]	Fire Mode was Act.
[198]	Drive Bypass
[211]	Lead Pump Alternate1
[212]	Fixed Speed Pump 1
[213]	Fixed Speed Pump 2

Analog Output

The analog output (AO 42, parameter 6-50) can be configured to output various controller parameters. This output is a current output (0-20mA or 4-20mA). Refer to the Common Terminal Wiring section in this manual for details on wiring. The list of analog output configuration options is shown below.

Option	Function
[0]*	No operation
[100]	Output freq. 0-100 0-100 Hz, (0-20 mA)
[101]	Reference Min-Max Minimum reference – Maximum Reference, (0-20 mA)
[102]	Feedback +-200% -200% to +200% of [20-14] Maximum Reference/Feedb., (0-20 mA)
[104]	Torque 0-Tlim 0-Torque limit ([4-16] Torque Limit Motor Mode), (0-20 mA)
[105]	Torque 0-Tnom 0-Motor rated torque, (0-20 mA)
[106]	Power 0-Pnom 0-Motor rated power, (0-20 mA)
[107]*	Speed 0-HighLim 0-Speed High Limit ([4-13] Motor Speed Limit [RPM] and [4-14] Motor Speed High Limit [Hz]), (0-20 mA)
[113]	Ext. Closed Loop 1 0-100%, (0-20 mA)
[114]	Ext. Closed Loop 2 0-100%, (0-20 mA)
[115]	Ext. Closed Loop 3 0-100%, (0-20 mA)
[130]	Out frq 0-100 4-20mA 0-100 Hz
[131]	Reference 4-20mA Minimum Reference – Maximum Reference
[132]	Feedback 4-20mA -200% to +200% of [20-14] Maximum Reference/Feedb.
[133]	Motor cur. 4-20 mA 0-Inverter Max. Current ([16-37] Inv. Max. Current)
[134]	Torq.0-lim 4-20 mA 0-Torque limit ([4-16] Torque Limit Motor Mode)
[135]	Torq.0-nom 4-20 mA 0-Motor rated torque
[136]	Power 4-20 mA 0-Motor rated power
[137]	Speed 4-20 mA 0-Speed High Limit ([4-13] and [4-14])
[139]	Bus ctrl. 0-100%, (0-20 mA)
[140]	Bus ctrl. 4-20 mA 0-100%

Option		Function
[141]	Bus ctrl. t.o.	0-100%, (0-20 mA)
[142]	Bus ctrl t.o. 4-20 mA	0-100%
[143]	Ext. Cl. 1 4-20 mA	0-100%
[144]	Ext. Cl. 2 4-20 mA	0-100%
[145]	Ext. Cl. 3 4-20 mA	0-100%

7.5.6 Communication Setup

The Genie can be used to setup the on board fieldbus communications through the RS485 port. Various protocols are supported. Select the desired protocol from the first menu. Supported protocols include Modbus RTU, Metasys N2, FLN, BACnet, FC Option and FCMC. The FC Option is used when the onboard RS485 port is connected to a gateway such as a BACnet gateway. The FCMC protocol is used for downloading software to the controller or parameters from the MCT10 tool.



A slightly different set of parameters must be configured to setup each protocol. Use the Genie to guide the setup of each protocol.

Copy to LCP

The LCP can be used to store or save a parameter configuration. It is recommended to copy all parameters to the LCP after commissioning the controller or prior to making adjustments during troubleshooting. Select [Yes] from the menu in the Genie then and press [OK] to begin copying parameters to the LCP. Parameter 0-50 LCP Copy can also be used to copy all parameters from all setups to the LCP.

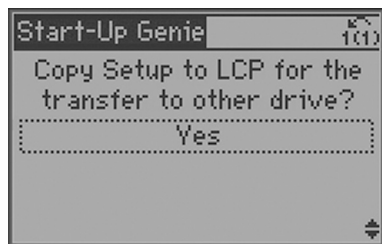

Copy from LCP

After parameters are stored to the LCP they can be downloaded to the same controller to restore the previous state of the controller or to another controller for fast setup. Either all parameters or only size independent parameters can be downloaded from the LCP to the controller. Select [All] from the *Copy Setup from LCP* menu to download all parameters from the LCP to the controller. Select [Application only] from the *Copy Setup from LCP* menu to download all size independent parameters from the LCP to the controller.

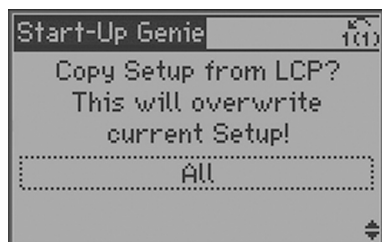

NOTE: Some settings made in the Start-Up Genie are not stored as a drive parameter. These settings will not be copied to or from the LCP. These settings include Motor Type, Operating Mode, Application Type, Number Feedback Sources and Number of Setpoints. Be sure to enter the Start-Up Genie and configure these settings before using the Copy Setup from LCP function.

The LCP can be used to store or save a parameter configuration. It is recommended to copy all parameters to the LCP after commissioning the controller or prior to making adjustments during troubleshooting. Select [Yes] from the menu in the Genie then and press [OK] to begin copying parameters to the LCP. Parameter 0-50 LCP Copy can also be used to copy all parameters from all setups to the LCP.

7.5.7 Automatic motor adaptation

Automatic motor adaptation (AMA) is a test procedure that measures the electrical characteristics of the motor to optimize compatibility between the frequency converter and the motor.

- The frequency converter builds a mathematical model of the motor for regulating output motor current. The procedure also tests the input phase balance of electrical power. It compares the motor characteristics with the data entered in parameters 1-20 to 1-25.
- The motor shaft does not turn and no harm is done to the motor while running the AMA.
- Some motors may be unable to run the complete version of the test. In that case, select [2] *Enable reduced AMA*.
- If an output filter is connected to the motor, select *Enable reduced AMA*.
- If warnings or alarms occur, see Warnings and alarms section for details.
- Run this procedure on a cold motor for best result.

NOTE: The AMA algorithm does not work when using PM motors.

To run AMA:

1. Press [Main Menu] to access parameters.
2. Scroll to parameter group 1-** Load and Motor
3. Press [OK].
4. Scroll to parameter group 1-2* Motor Data.
5. Press [OK].
6. Scroll to 1-29 Automatic Motor Adaptation (AMA).
7. Press [OK].
8. Select [1] Enable complete AMA.
9. Press [OK].
10. Follow on-screen instructions.
11. The test will run automatically and indicate when it is complete.

Date and time setting

The date and time can be set on the controller to help diagnostics and fault logging. To set the clock, enter the parameter list by pressing [Main Menu]. Use the up and down arrows to highlight 0-** Operation/Display menu and press [OK] to enter the menu. Next, use the up and down arrows to highlight 0-7* *Clock Settings* and press [OK] to select. Use the up and down arrows to select parameter 0-70 *Date and Time*. Press [OK] to enabling editing of the Date and Time parameter. First set the time. Use the up and down arrows to set the minutes. Then use the left arrow key to scroll left to the hours. Use the up and down arrows to set the hour of the day. To change to PM, press the up arrow key until the desired hours and the letter P (found between the minutes and day of the week) are shown on the display. Next, scroll to the left to set the date. The day of the week on the right side will update according to the date selected. Press [OK] to save the changes.

NOTE: If the power to the unit is lost, the date and time will reset to factory defaults. Battery backup for real time clock is available on the Analog I/O Option Card (Input/Output Option "A" or Repair part number 9K653).

7.6 Basic operational programming

Required initial frequency converter programming

NOTE: If the Start-Up Genie is run, ignore the following.

Frequency converters require basic operational programming before running for best performance. Basic operational programming requires entering motor-nameplate data for the motor being operated and the minimum and maximum motor speeds. Enter data in accordance with the following procedure. Parameter settings recommended are intended for start up and checkout purposes. Application settings may vary. See the Local Control Panel section for detailed instructions on entering data through the LCP.

Enter data with power ON, but before operating the frequency converter.

1. Press [Main Menu] twice on the LCP.
2. Use the navigation keys to scroll to parameter group 0-** Operation/Display and press [OK].

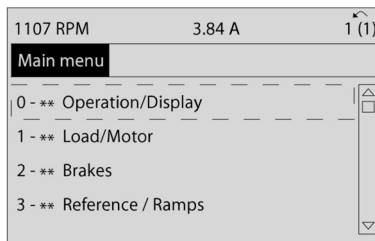

Figure 41: Main menu

3. Use navigation keys to scroll to parameter group 0-0* Basic settings and press [OK].

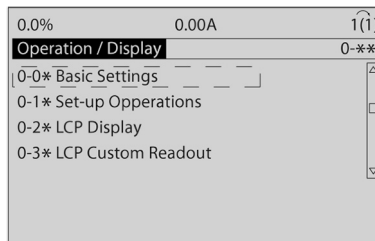

Figure 42: Operation/display

4. Use navigation keys to scroll to 0-3 Regional Settings and press [OK].

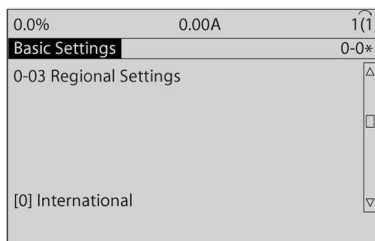

Figure 43: Basic settings

5. Use navigation keys to select [0] International or [1] North America as appropriate and press [OK]. This changes the default settings for a number of basic parameters. See 5.4 International/North American Default Parameter Settings for a complete list.)
6. Press [Quick Menu] on the LCP.
7. Use the navigation keys to scroll to parameter group Q2 Quick Setup and press [OK].



Figure 44: Quick menus

8. Select language and press [OK].
9. A jumper wire should be in place between control terminals 12 and 27. If this is the case, leave *5-12 Terminal 27 Digital Input* at factory default. Otherwise select *No Operation*. For frequency converters with an optional Xylem bypass, no jumper wire is required.
- 10.3-02 *Minimum Reference*
- 11.3-03 *Maximum Reference*
- 12.3-41 *Ramp 1 Ramp Up Time*
- 13.3-42 *Ramp 1 Ramp Down Time*
- 14.3-13 *Reference Site*. Linked to Hand/Auto* Local

7.7 Induction motor setup

Enter the motor data in parameters 1-20/1-21 to 1-25. The information can be found on the motor nameplate.

1. - 1-20 *Motor Power [kW]* or 1-21 *Motor Power [HP]*
 - 1-22 *Motor Voltage*
 - 1-23 *Motor Frequency*
 - 1-24 *Motor Current*
 - 1-25 *Motor Nominal Speed*

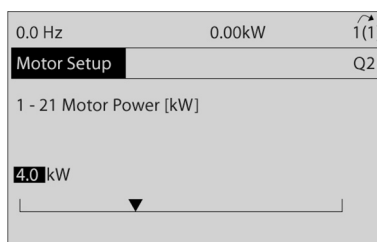

Figure 45: Motor setup

7.8 PM motor setup



CAUTION:

Only use PM motor with fans and pumps.



WARNING:

WINDMILLING! Unintended rotation of permanent magnet motors causes a risk of personal injury and equipment damage. Ensure permanent magnet motors are blocked to prevent unintended rotation.

Initial programming steps

1. Activate PM motor operation *1-10 Motor Construction*, select [1] *PM, non salient SPM*
2. Make sure to set *0-02 Motor Speed Unit* to [0] *RPM*

Programming motor data

After selecting PM motor in *1-10 Motor Construction*, the PM motor-related parameters in parameter groups *1-2* Motor Data*, *1-3* Adv. Motor Data* and *1-4** are active.

The information can be found on the motor nameplate and in the motor data sheet.

The following parameters must be programmed in the listed order:

1. *1-24 Motor Current*
2. *1-26 Motor Cont. Rated Torque*
3. *1-25 Motor Nominal Speed*
4. *1-39 Motor Poles*
5. *1-30 Stator Resistance (Rs)*
 - a. Enter line to common stator winding resistance (Rs). If only line-line data are available, divide the line-line value with 2 to achieve the line to common (starpoint) value.
 - b. It is also possible to measure the value with an ohmmeter, which will also take the resistance of the cable into account. Divide the measured value by 2 and enter the result.
6. *1-37 d-axis Inductance (Ld)*
 - a. Enter line to common direct axis inductance of the PM motor.
 - b. If only line-line data are available, divide the line-line value with 2 to achieve the line-common (starpoint) value.
 - c. It is also possible to measure the value with an inductance meter, which will also take the inductance of the cable into account. Divide the measured value by 2 and enter the result.
7. *1-40 Back EMF at 1000 RPM*
 - a. Enter line to line back EMF of PM Motor at 1000 RPM mechanical speed (RMS value). Back EMF is the voltage generated by a PM motor when no drive is connected and the shaft is turned externally. Back EMF is normally specified for nominal motor speed or for 1000 RPM measured between two lines. If the value is not available for a motor speed of 1000 RPM, calculate the correct value as follows: If back EMF is e.g. 320 V at 1800 RPM, it can be calculated at 1000 RPM as follows: $\text{Back EMF} = (\text{Voltage} / \text{RPM}) * 1000 = (320/1800) * 1000 = 178$. This is the value that must be programmed for 1-40 Back EMF at 1000 RPM.

Test motor operation

1. Start the motor at low speed (100 to 200 RPM). If the motor does not turn, check installation, general programming and motor data.
2. Check if start function in *1-70 PM Start Mode* fits the application requirements.

Rotor detection

This function is the recommended choice for applications where the motor starts from standstill e.g. pumps or conveyors. On some motors, an acoustic sound is heard when the impulse is sent out. This does not harm the motor.

Parking

This function is the recommended choice for applications where the motor is rotating at slow speed eg. windmilling in fan applications. *2-06 Parking Current* and *2-07 Parking Time* can be adjusted. Increase the factory setting of these parameters for applications with high inertia.

Start the motor at nominal speed. In case the application does not run well, check the VVC^{plus} PM settings.

Recommendations in different applications can be seen in the following table:

Table 25: Recommendations in different applications

Application	Settings
Low inertia applications $I_{Load}/I_{Motor} < 5$	<ul style="list-style-type: none"> • 1-17 Voltage filter time const. to be increased by factor 5 to 10 • 1-14 Damping Gain should be reduced • 1-66 Min. Current at Low Speed should be reduced (<100%)
Low inertia applications $5 > I_{Load}/I_{Motor} > 5$	Keep calculated values
High inertia applications $I_{Load}/I_{Motor} > 50$	1-14 Damping Gain, 1-15 Low Speed Filter time Const. and 1-16 High Speed Filter Time Const. should be increased
High load at low speed <30% (rated speed)	1-17 Voltage filter time const. should be increased 1-66 Min. Current at Low Speed should be increased (>100% for longer time can overheat the motor)

If the motor starts oscillating at a certain speed, increase 1-14 Damping Gain. Increase the value in small steps.

Depending on the motor, a good value for this parameter can be 10% or 100% higher than the default value.

Starting torque can be adjusted in 1-66 Min. Current at Low Speed. 100% provides nominal torque as starting torque.

7.9 Check motor rotation

Before running the frequency converter, check the motor rotation. The motor will run briefly at 5 Hz or the minimum frequency set in 4-12 Motor Speed Low Limit [Hz].

1. Press [Quick Menu].
2. Scroll to Q2 Quick Setup.
3. Press [OK].
4. Scroll to 1-28 Motor Rotation Check.
5. Press [OK].
6. Scroll to [1] Enable.

The following text will appear: *NOTE! Motor may run in wrong direction.*

7. Press [OK].
8. Follow the on-screen instructions.

To change the direction of rotation, remove power to the frequency converter and wait for power to discharge. Reverse the connection of any two of the three motor cables on the motor or frequency converter side of the connection.

7.10 Local-control test



CAUTION:

MOTOR START. Ensure that the motor, system and any attached equipment are ready for start. It is the responsibility of the user to ensure safe operation under any condition.

NOTE: The [Hand On] key provides a local start command to the frequency converter. The [Off] key provides the stop function.

When operating in local mode, [▲] and [▼] increase and decrease the speed output of the frequency converter. [◀] and [▶] move the display cursor in the numeric display.

1. Press [Hand On].
2. Accelerate the frequency converter by pressing [▲] to full speed. Moving the cursor left of the decimal point provides quicker input changes.
3. Note any acceleration problems.
4. Press [Off].
5. Note any deceleration problems.

If acceleration problems were encountered:

- If warnings or alarms occur, see Warnings and Alarms section for details.
- Check that motor data is entered correctly.
- Increase the ramp-up time in *3-41 Ramp 1 Ramp Up Time*
- Increase current limit in *4-18 Current Limit*
- Increase torque limit in *4-16 Torque Limit Motor Mode*

If deceleration problems were encountered:

- If warnings or alarms occur, see Warnings and Alarms section for details.
- Check that motor data is entered correctly.
- Increase the ramp-down time in *3-42 Ramp 1 Ramp Down Time*
- Enable overvoltage control in *2-17 Over-voltage Control*

See *Local Control Panel* for details on resetting the frequency converter after a trip.

7.11 System start-up

The procedure in this section requires user wiring and application programming to be completed. Application set-up examples are intended to help with this task. Other aids to application set-up are listed in 1.2 Additional Resources. The following procedure is recommended after application set-up by the user is completed.

NOTICE:

MOTOR START. Ensure that the motor, system and any attached equipment is ready for start.

1. Press [Auto On].
2. Ensure that external control function are properly wired to the frequency converter and all programming is completed.
3. Apply an external run command.
4. Adjust the speed reference throughout the speed range.
5. Remove the external run command.
6. Note any problems.

If warning or alarms occur, see Warnings and Alarms section for details on troubleshooting.

7.12 Acoustic noise or vibration

If the motor or the equipment driven by the motor, for example a pump impeller blade, is making noise or vibrations at certain frequencies, try the following:

- Speed Bypass, parameter group 4-6*
- Over-modulation, *14-03 Overmodulation* set to off
- Switching pattern and switching frequency parameter group 14-0*
- Resonance Dampening, *1-64 Resonance Dampening*

8 Warnings and alarms

8.1 System monitoring

The frequency converter monitors:

- The condition of its input power
- Output
- Motor factors
- Other system performance

A warning or alarm may not signal a frequency converter problem. It can also indicate the following:

- Failure conditions from input voltage
- Motor load
- Temperature
- External signals
- Other areas monitored by the frequency converter's internal logic

Be sure to check those areas exterior to the frequency converter as indicated in the warning or alarm.

8.2 Warning and alarm types

Warnings

A warning is issued when an alarm condition is impending or when an abnormal operating condition is present and may result in the frequency converter issuing an alarm. A warning clears by itself when the abnormal condition is removed.

Alarms

An alarm is issued when the frequency converter is tripped, that is, the frequency converter suspends operation to prevent frequency converter or system damage. The motor will coast to a stop. The frequency converter logic will continue to operate and monitor the frequency converter status. After the fault condition is remedied, the frequency converter can be reset. It will be ready to start operation again.

A trip can be reset in any of 4 ways:

- Press [Reset] on the LCP
- Digital reset input command
- Serial communication reset input command
- Auto reset

An alarm that causes the frequency converter to trip-lock requires that input power is cycled. The motor will coast to a stop. The frequency converter logic will continue to operate and monitor the frequency converter status. Remove input power to the frequency converter and correct the cause of the fault, then restore power. This action puts the frequency converter into a trip condition as described above and may be reset in any of those 4 ways.

8.3 Warning and alarm displays

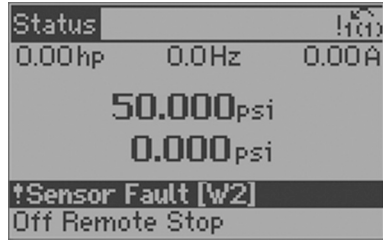

Figure 46: Warning display

An alarm or trip-lock alarm will flash along with the alarm number.

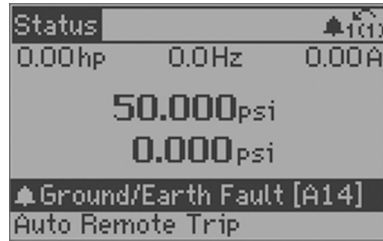

Figure 47: Alarm display

In addition to the text and alarm code on the frequency converter LCP, there are three status indicator lights.

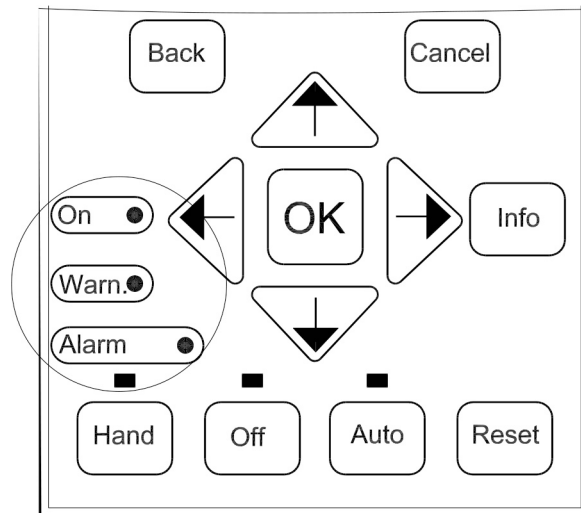

Figure 48: Status indicator lights

Table 26: Status indicator lights explanations

	Warning LED	Alarm LED
Warning	On	Off
Alarm	Off	On (Flashing)
Trip-Lock	On	On (Flashing)

Warnings/Alarm messages

A warning or an alarm is signaled by the relevant LED on the front of the frequency converter and indicated by a code on the display.

A warning remains active until its cause is no longer present. Under certain circumstances, operation of the motor may still be continued. Warning messages may be critical, but are not necessarily so.

In the event of an alarm, the frequency converter trips. Reset the alarm to resume operation once the cause has been rectified.

Three ways to reset:

- Press [Reset].
- Via a digital input with the "Reset" function.
- Via serial communication/optional fieldbus.

NOTE: After a manual reset pressing [Reset], press [Auto On] to restart the motor.

If an alarm can't be reset, the reason may be that its cause has not been rectified, or the alarm is trip-locked.

Alarms that are trip-locked offer additional protection, meaning that the mains supply must be switched off before the alarm can be reset. After being switched back on, the frequency converter is no longer blocked and can be reset as described above once the cause has been rectified.

Alarms that are not trip-locked can also be reset using the automatic reset function in [14-20] **Reset Mode** (Warning: Automatic wake-up is possible).

In some cases a warning will occur before an alarm is issued. This is possible, for instance, in [1-90] **Motor Thermal Protection**. After an alarm or trip, the motor continues to coast, and the alarm and warning flash. Once the problem has been rectified, only the alarm continues flashing until the frequency converter is reset.

NOTE: No missing motor phase detection (numbers 30-32) and no stall detection is active when [1-10] **Motor Construction** is set to [1] PM non salient SPM.

The following table defines whether a warning is issued before an alarm, and whether the alarm trips the unit or trip locks the unit.

Table 27: Alarm/Warning code list

Number	Description	Warning	Alarm/Trip	Alarm/Trip Lock	Parameter Reference
1	10 volts low	X			
2	Sensor Fault	(X)	(X)		[6-01] Sensor Fault Timeout Function
3	No motor	(X)			[1-80] Function at Stop
4	Input Phase Loss	(X)	(X)	(X)	[14-12] Function at Mains Imbalance Function at Sensor Fault
5	DC link voltage high	X			
6	DC link voltage low	X			
7	DC overvoltage	X	X		
8	DC undervoltage	X	X		
9	Inverter overloaded	X	X		
10	Motor ETR over-temperature	(X)	(X)		[1-90] Motor Temperature
11	Motor thermistor over temperature	(X)	(X)		[1-90] Motor Temperature
12	Torque limit	X	X		
13	Over current	X	X	X	
14	Ground/earth fault	X	X		
15	Hardware mismatch		X	X	

Number	Description	Warning	Alarm/Trip	Alarm/Trip Lock	Parameter Reference
16	Short circuit		X	X	
17	Control word timeout	(X)	(X)		[8-04] Control Timeout Function
18	Start Failed		X		[1-77] Compressor Start Max Speed [RPM], [1-79] Compressor Start Max Time to Trip, [1-03] Torque Characteristics
20	Temp. Input Error				
21	Param error				
22	Hoist Mech. Brake	(X)	(X)		Parameter group 2-2*
23	Internal fans	X			
24	External fans	X			
25	Brake resistor short-circuited	X			
26	Brake resistor power limit	(X)	(X)		[2-13] Brake Power Monitoring
27	Brake chopper short-circuited	X	X		
28	Brake check	(X)	(X)		[2-15] Brake Check
29	Heatsink temp	X	X	X	
30	Motor phase U missing	(X)	(X)	(X)	[4-58] Missing Motor Phase Function
31	Motor phase V missing	(X)	(X)	(X)	[4-58] Missing Motor Phase Function
32	Motor phase W missing	(X)	(X)	(X)	[4-58] Missing Motor Phase Function
33	Inrush fault		X	X	
34	Fieldbus communication fault	X	X		
35	Option fault				
36	Mains failure	X	X		
37	Phase imbalance (Not applicable for single phase drives).		X		
38	Internal fault		X	X	
39	Heatsink sensor		X	X	
40	Overload of Digital Output Terminal 27	(X)			[5-00] Digital I/O mode, [5-01] Terminal 27 Mode
41	Overload of Digital Output Terminal 29	(X)			[5-00] Digital I/O mode, [5-02] Terminal 29 Mode
42	Ovrlld X30/6-7	(X)			
43	Ext. Supply (option)				
45	Earth Fault 2	X	X		
46	Pwr. card supply		X	X	
47	24 V supply low	X	X	X	

Number	Description	Warning	Alarm/Trip	Alarm/Trip Lock	Parameter Reference
48	1.8 V supply low		X	X	
49	Speed limit		X		[1-86] Trip Speed Low [RPM]
50	AMA calibration failed		X		
51	AMA check U_{nom} and I_{nom}		X		
52	AMA low I_{nom}		X		
53	AMA motor too big		X		
54	AMA motor too small		X		
55	AMA parameter out of range		X		
56	AMA interrupted by user		X		
57	AMA time-out		X		
58	AMA internal fault	X	X		
59	Current limit	X			
60	Pump Protect (North America)/External Interlock (International)	X	X		
61	Feedback Error	(X)	(X)		[4-30] Motor Feedback Loss Function
62	Output Frequency at Maximum Limit	X			
63	Mechanical Brake Low		(X)		[2-20] Release Brake Current
64	Voltage Limit	X			
65	Control Board Over-temperature	X	X	X	
66	Heat sink Temperature Low	X			
67	Option Configuration has changed		X		
68	Safe Stop	(X)	(X) ¹⁾		[5-19] Terminal 37 Safe Stop
69	pwr. Card Temp		X	X	
70	Illegal FC configuration			X	
71	PTC 1 Safe Stop				
72	Dangerous failure				
73	Safe Stop Auto Restart	(X)	(X)		[5-19] Terminal 37 Safe Stop
74	PTC Thermistor			X	
75	Illegal Profile Sel.		X		
76	Power Unit Setup	X			
77	Reduced power mode	X			[14-59] Actual Number of Inverter Units

Number	Description	Warning	Alarm/Trip	Alarm/Trip Lock	Parameter Reference
78	Tracking Error	(X)	(X)		[4-34] Tracking Error Function
79	Illegal PS config		X	X	
80	Drive initialized to Default value		X		
81	CSIV corrupt		X		
82	CSIV parameter error		X		
83	Illegal Option Combination			X	
84	No Safety Option		X		
85	Dang fail PB				
86	Dang fail DI				
88	Option Detection			X	
89	Mechanical Brake Sliding	Z			
90	Feedback Monitor	(X)	(X)		[17-61] Feedback Signal Monitoring
91	Analog input 54 wrong settings			X	5202
92	No Flow	X	X		[22-2]* No-Flow Detection
93	No Water/Loss of Prime (North America) Dry Pump (International)	X	X		[22-2]* No-Flow Detection
94	Under pressure	X	X		[22-5]*
95	Broken Belt	X	X		[22-6]*
96	Start Delayed	X			[22-7]*
97	Stop Delayed	X			[22-7]*
98	Clock Fault	X			[0-7]* Clock Settings
102	Too many CAN objects				
103	Illegal axis num.				
104	Mixing fans				
105	Error not reset				
106	HOME not done				
107	Home vel zero				
108	Position error				
109	Index not found				
110	Unknown cmd.				
111	SW end limit				
112	Unknown param				
113	FC not enabled				
114	Too many loops				
115	Par. save failed				
116	Param. memory				
117	Progr. memory				

Number	Description	Warning	Alarm/Trip	Alarm/Trip Lock	Parameter Reference
118	Reset by CPU				
119	User abort.				
121	No more SDO channels				
125	HW end limit				
149	Too many inter.				
150	No ext. 24 V				
151	GOSUB > limit				
152	Return @ limit				
154	D.out overload				
155	LINK failed				
156	Illegal double arg.				
160	Internal Intr. error				
162	Memory error				
163	ATEX ETR cur.lim.warning	X			
164	ATEX ETR cur.lim.alarm		X		
165	ATEX ETR freq.lim.warning	X			
166	ATEX ETR freq.lim.alarm		X		
201	Fire M was Active				
202	Fire M Limits Exceeded				
203	Missing Motor				
204	Locked Rotor				
243	Brake IGBT	X	X		
244	Heatsink temp	X	X	X	
245	Heatsink sensor		X	X	
246	Pwr. card supply				
247	Pwr. card temp		X	X	
248	Illegal PS config		X	X	
250	New spare parts			X	
251	New Type Code		X	X	
(X) Dependent on parameter					
1) Cannot be Auto reset via 14-20 Reset Mode					

A trip is the action following an alarm. The trip coasts the motor and is reset by pressing [Reset] or by a digital input (parameter group 5-1* *Digital Inputs* [1]). The origin event that caused the alarm cannot damage the frequency converter or cause dangerous conditions. A trip lock is an action when an alarm occurs, which could damage the frequency converter or connected parts. A trip lock situation can only be reset by a power cycling.

Table 28: LED indication

Warning	Yellow
Alarm	Flashing red

Trip locked	Yellow and red
-------------	----------------

The following table defines the alarm words, warning words and extended status words that can be read out via serial bus or optional fieldbus for diagnostics, or through 16-94 Ext. Status Word.

Table 29: Description of Alarm word, Warning word and Extended Status word

Bit	Hex	Dec	Alarm word	Alarm word 2	Warning word	Warning word 2	Extended Status word	Extended Status word 2
Alarm Word Extended Status Word								
0	00000001	1	Brake Check (A28)	ServiceTrip, read/write	Brake Check (W28)	Start Delayed	Ramping	Off
1	00000002	2	Pwr.card temp (A69)	ServiceTrip, (reserved)	Pwr.card temp (A69)	Stop Delayed	AMA Running	Hand/Auto
2	00000004	4	Ground/Earth Fault (A14)	ServiceTrip, Typecade/ sparepart	Ground/Earth Fault (W14)	reserved	Start CW/CCW start_possible is active, when the DI selections [12] OR [13] are active and the requested direction matches the reference sign	Profibus OFF1 active
3	00000008	8	Ctrl.Card Temp (A65)	ServiceTrip, (reserved)	Ctrl.Card Temp (W65)	reserved	Slow Down slow down command active, e.g. via CTW bit 11 oe DI	Profibus OFF2 active
4	00000010	16	Ctrl. Word TO (A17)	ServiceTrip, (reserved)	Ctrl. Word TO (W17)		Catch Up catch up comand active, e.g. via CTW bit 12 or DI	Profibus OFF3 active
5	00000020	32	Over Current (A13)	reserved	Over Current (W13)	reserved	Feedback High feedback > 4-57	Relay 123 active
6	00000040	64	Torque Limit (12)	reserved	Torque Limit (W12)	reserved	Feedback Low feedback < 4-56	Start Prevented
7	00000080	128	Motor Th Over (A11)	reserved	Motor Th Over (W11)	reserved	Output Current High current > 4-51	Control Ready
8	00000100	256	Motor ETR Over (A10)	reserved	Motor ETR Over (W10)	reserved	Output Current Low current < 4-50	Drive Ready
9	00000200	512	Inverter Overld. (A9)	Discharge High	Onverter Overld (W9)	Discharge High	Output Freq High speed > 4-53	Quick Stop

Bit	Hex	Dec	Alarm word	Alarm word 2	Warning word	Warning word 2	Extended Status word	Extended Status word 2
Alarm Word Extended Status Word								
10	00000400	1024	DC under Volt (A8)	Start Failed	SC under Volt (W8)	Multi-motor underload	Output Freq Low speed < 4-52	DC Brake
11	00000080	2048	DC over Volt (A7)	Speed Limit	SC over Volt (W7)	Multi-motor Overload	Brake Check OK brake test NOT ok	Stop
12	00001000	4096	Short Circuit (A16)	Pump Protect (North America)/ External Interlock (International)	DC Voltage Low (W6)	Compress or Interlock	Braking Max BrakePower > BrakePowerLimit (2-12)	Stand by
13	00002000	8192	Inrush Fault (A33)	Illegal Option Combi.	DC Voltage High (W5)	Mechanical Brake Sliding	Braking	Freeze Output Request
14	00004000	16384	Input Phase Loss (A4)	No Safety Option	Mains ph. Loss (W4)	Safe Option Warning	Out of Speed Range	Freeze Output
15	00008000	32768	AMA not OK	reserved	No Motor (W3)	Auto DC Braking	OVC Active	Jog Request
16	00010000	65536	Sensor Fault (A2)	reserved	Sensor Fault (W2)		AC Brake	Jog
17	00020000	131072	Internal Fault (A38)	KTY error	10V Low (W1)	KTY Warn	Password Timelock number of allowed password trials exceeded - timelock active	Start Request
18	00040000	262144	Brake Overload (A26)	Fans error	Brake Overload (W26)	Fans Warn	Password Protection 0-61 = ALL_NO_ACCESS OR BUS_NO_ACCESS OR BUS_READONLY	Start
19	00080000	524288	U phase Loss (A30)	ECB error	Brake Resistor (W25)	ECB Warn	Reference High reference > 4-55	Start Applied
20	00100000	1048576	V phase Loss (AA31)	reserved	Brake IGBT (W27)	reserved	Reference Low reference < 4-54	Start delay
21	00200000	2097152	W phase Loss (A32)	reserved	Speed Limit (W49)	RESERVED	Local Reference reference site = REMOTE > auto on pressed & active	Sleep

Bit	Hex	Dec	Alarm word	Alarm word 2	Warning word	Warning word 2	Extended Status word	Extended Status word 2
Alarm Word Extended Status Word								
22	00400000	4194304	Fieldbus Fault (A34)	reserved	Fieldbus Fault (W34)	reserved	Protection mode notification	Sleep Boost
23	00800000	8388608	24 V Supply Low (A47)	reserved	24V Supply Low (W47)	reserved	Unused	Running
24	01000000	16777216	Mains Failure (A36)	reserved	Mains Failure (W36)	reserved	Unused	Drive Bypass
25	02000000	33554432	1.8V Supply Low (A48)	Current Limit (W59)	Current Limit (A59)	reserved	Unused	Fire Mode
26	04000000	67108864	Brake Resistor (A25)	reserved	Low Temp (W66)	reserved	Unused	Pump Protect (North America)/ External Interlock (International)
27	08000000	134217728	Brake IGBT (A27)	reserved	Voltage Limit (W64)	reserved	Unused	Firemode Limit Exceed
28	10000000	268435456	Option Change (A67)	reserved	Encoder loss (W90)	reserved	Unused	FlyStart active
29	20000000	536870912	Drive Initialized (A80)	Encoder loss (A90)	Output freq. lim. (W62)	BackEMF too High	Unused	
30	40000000	1073741824	Safe Stop (A68)	PTC Thermistor (A74)	Safe Stop (W68)	PTC Thermistor (W74)	Unused	
31	80000000	2147483648	Mech. brake low (A63)	Dangerous failure (A72)	Extended Status Word		Protection Mode	

8.4 Warnings and alarms

Table 30: Warnings and alarms

Warning/Alarm	Description	Cause	Remedy
1 – 10 V low	The control card voltage is below 10 V from terminal 50.	A short in a connected potentiometer or improper wiring of the potentiometer.	Remove the wiring from terminal 50. If the warning clears, the problem is with the customer wiring.
2 – Sensor Fault Note: this warning/alarm is not available when the MCO301 Programmable API option card is installed and functioning.	This warning or alarm will only appear if programmed by the user in [6-01] Sensor Fault Timeout Function . The signal on one of the analog inputs is less than 50% of the minimum value that is programmed for that input.	Broken wiring or faulty device sending the signal.	Check the connections on all the analog input terminals. Control card terminals 53 and 54 for signals, terminal 55 common. General Purpose I/O Option Card terminals 11 and 12 for signals, terminal 10 common. Analog I/O Option Card terminals 1, 3, 5 for signals, terminals 2, 4, 6 common. Check that the frequency converter programming and switch settings match the analog signal type. Perform Input Terminal Signal Test

Warning/Alarm	Description	Cause	Remedy
4 – Input phase loss	A phase is missing on the supply side, or the mains voltage imbalance is too high. This message also appears for a fault in the input rectifier on the frequency converter. Options are programmed at [14–12] Function at Mains Imbalance (not applicable for single-phase drives).		Check the supply voltage and supply currents to the frequency converter.
5 – DC link voltage high	The intermediate circuit voltage (DC) is higher than the high voltage warning limit.	The limit is dependent on the frequency converter voltage rating. The frequency converter is still active.	
6 – DC link voltage low	The intermediate circuit voltage (DC) is lower than the low voltage warning limit.	The limit is dependent on the frequency converter voltage rating. The frequency converter is still active.	
7 – DC overvoltage	If the intermediate circuit voltage exceeds the limit, the frequency converter trips after a time.		Connect a brake resistor Extend a ramp time Change the ramp type Activate functions in [2–10] Brake Function Increase [14–26] Trip Delay at Inverter Fault
8 – DC under voltage	If the intermediate circuit voltage (DC) drops below the under voltage limit, the frequency converter checks if a 24 VDC backup supply is connected.	If no 24 VDC backup supply is connected, the frequency converter trips after a fixed time delay. The time delay varies with unit size.	Check that the supply voltage matches the frequency converter voltage. Perform input voltage test Perform soft charge and rectifier circuit test.
9 – Inverter overloaded	The frequency converter is about to cut-out because of an overload (too high current for too long). The counter for electronic, thermal inverter protection gives a warning at 98% and trips at 100% while giving an alarm. The frequency converter cannot be reset until the counter is below 90%.	The fault is that the frequency converter is overloaded by more than 100% for too long.	Compare the output current shown on the LCP with the frequency converter rated current. Compare the output current shown on the LCP with the measured motor current. Display the Thermal Drive Load on the LCP and
10 – Motor overload temperature	According to the electronic thermal protection (ETR), the motor is too hot. Select whether the frequency converter gives a warning or an alarm when the counter reaches 100% in [1–90] Motor Thermal Protection .	The fault occurs when the motor is overloaded by more than 100% for too long.	Check for motor overheating. Check if the motor is mechanically overloaded. Check that the motor current set in [1–24] Motor Current is correct.

Warning/Alarm	Description	Cause	Remedy
11 – Motor thermistor over temp	The thermistor might be disconnected. Select whether the frequency converter gives a warning or an alarm in [1-90] Motor Thermal Protection .		<p>Check for motor overheating.</p> <p>Check if the motor is mechanically overloaded.</p> <p>When using terminal 54, check that the thermistor is connected correctly between terminal 54 (analog voltage input) and terminal 50 (+10 V supply) and that the terminal switch for 54 is set for voltage. Check [1-93] Thermistor Source selects terminal 54.</p> <p>When using digital inputs 18 or 19, check that the thermistor is connected correctly between either terminal 18 or 19 (digital input PNP only) and terminal 50. Check [1-93] Thermistor Source selects terminal 18 or 19.</p>
12 – Torque limit	The torque has exceeded the value in [4-16] Torque Limit Motor Mode or the value in [4-17] Torque Limit Generator Mode . [14-25] Trip Delay at Torque Limit can change this from a warning only condition to a warning followed by an alarm.		<p>If the motor torque limit is exceeded during ramp up, extend the ramp up time.</p> <p>If the generator torque limit is exceeded during ramp down, extend the ramp down time.</p> <p>If torque limit occurs while running, possibly increase the torque limit. Be sure the system can operate safely at a higher torque.</p> <p>Check the application for excessive current draw on the motor.</p>
13 – Over current	The inverter peak current limit (approximately 200% of the rated current) is exceeded. The warning lasts about 1.5 seconds, then the frequency converter trips and issues an alarm. This fault may be caused by shock loading or fast acceleration with high inertia loads. If extended mechanical brake control is selected, trip can be reset externally.		<p>Remove power and check if the motor can be turned.</p> <p>Check that the motor size matches the frequency converter.</p> <p>Check parameters [1-20] through [1-25] for correct motor data.</p>
14 – Ground/Earth fault	There is current from the output phases to ground, either in the cable between the frequency converter and the motor or in the motor itself.		<p>Remove power to the frequency converter and repair the earth fault.</p> <p>Check for ground faults in the motor by measuring the resistance to ground of the motor leads and the motor megohmmeter.</p>

Warning/Alarm	Description	Cause	Remedy
15 – Hardware mismatch	A fitted option is not operational with the present control board hardware or software.		Record the value of the following parameters and contact your Xylem supplier: <ul style="list-style-type: none"> • [15-40] FC Type • [15-41] Power Section • [15-42] Voltage • [15-43] Software Version • [15-45] Actual Typecode String • [15-49] SW ID Control Card • [15-50] SW ID Power Card • [15-60] Option Mounted • [15-61] Option SW Version
16 – Short circuit	There is a short circuit in the motor or motor wiring.		Remove power to the frequency converter and repair the short circuit.
17 – Control word timeout	There is no communication to the frequency converter. The warning will only be active when [8-04] Control Timeout Function is NOT set to [0] OFF.	If [8-04] Control Timeout Function is set to Stop and Trip, a warning appears and the frequency converter ramps down until it stops then displays an alarm.	Check connections on the series communication cable. Increase [8-03] Control Timeout Time Check operation of the communication equipment Verify proper installation based on EMC requirements.
18 – Start failed	The speed has not been able to exceed [1-77] Compressor Start Max Speed [RPM] during start within the allowed time. (set in [1-79] Compressor Start Max Time to Trip).	This may be caused by a blocked motor.	
23 – Internal fan fault	The fan warning function checks if the fan is running. The fan warning can be disabled on [14-53] Fan Monitor .		Check for proper fan operation. Cycle power to the frequency converter and check that the fan operates briefly at startup. Check the sensors on the heatsink and control card.
24 – External fan fault	The fan warning function checks if the fan is running. The fan warning can be disabled on [14-53] Fan Monitor .		Check for proper fan operation. Cycle power to the frequency converter and check that the fan operates briefly at startup. Check the sensors on the heatsink and control card.
25 – Brake resistor short circuit	The brake resistor is monitored during operation. If a short circuit occurs, the brake function is disabled and the warning appears. The frequency converter is still operational but without the brake function.		Remove power to the frequency converter and replace the brake resistor (see [2-15] Brake Check).

Warning/Alarm	Description	Cause	Remedy
26 – Brake resistor power limit	The power transmitted to the brake resistor is calculated as a mean value over the last 120 seconds of run time. The calculation is based on the intermediate circuit voltage and the brake resistance value set in [2-16] AC brake Max.Current .	The warning is active when the dissipated braking is higher than 90% of the brake resistance power. If Trip [2] is selected in [2-13] Brake Power Monitoring , the frequency converter will trip when the dissipated braking power reaches 100%.	
27 – Brake chopper fault	The brake transistor is monitored during operation and if a short circuit occurs, the brake function is disabled and a warning is issued.	The frequency converter is still operational but, since the brake transistor has short-circuited, substantial power is transmitted to the brake resistor, even if it is inactive.	Remove power to the frequency converter and remove the brake resistor.
28 – Brake check failed	The brake resistor is not connected or not working.		Check [2-15] Brake Check .
29 – Heatsink temp	The maximum temperature of the heatsink has been exceeded. The temperature fault will not reset until the temperature falls below the reset heatsink temperature. The trip and reset points are based on the frequency converter power size.		Check for the following conditions: <ul style="list-style-type: none"> • Ambient temperature too high. • Motor cable too long. • Incorrect airflow clearance above and below the frequency converter. • Blocked airflow around the frequency converter. • Damaged heatsink fan. • Dirty heatsink.
30 – Motor phase U missing	Motor phase U between the frequency converter and the motor is missing.		Remove power from the frequency converter and check motor phase U.
31 – Motor phase V missing	Motor phase V between the frequency converter and the motor is missing.		Remove power from the frequency converter and check motor phase V.
32 – Motor phase W missing	Motor phase W between the frequency converter and the motor is missing.		Remove power from the frequency converter and check motor phase W.
33 – Inrush fault	Too many power-ups have occurred within a short time period.		Let the unit cool to operating temperature.
34 – Fieldbus communication fault	Communication between the fieldbus and the communication option card is not operating.		
36 – Mains failure	This warning/alarm is only active if the supply voltage to the frequency converter is lost and [14-10] Mains Failure is NOT set to [0] No Function.		Check the fuses to the frequency converter and mains power supply to the unit.

Warning/Alarm	Description	Cause	Remedy
38 – Internal fault	When an internal fault occurs, a code number defined in the table below is displayed.		Cycle power to the frequency converter. Check that the option is properly installed. Check for loose or missing wiring. It may be necessary to contact your Xylem supplier or service department. Note the code number for further troubleshooting directions.
39 – Heatsink sensor	No feedback from the heatsink temperature sensor.	The signal from the IGBT Thermal sensor is not available on the power card. The problem could be on the power card, on the gate drive card, or the ribbon cable between the power card and gate drive card.	
40 – Overload of digital output terminal 27			Check the load connected to terminal 27 or remove short-circuit connection. Check [5-00] Digital I/O mode and [5-01] Terminal 27 Mode .
41 – Overload of digital output terminal 29			Check the load connected to terminal 29 or remove short-circuit connection. Check [5-00] Digital I/O mode and [5-02] Terminal 29 Mode .
42 – Overload of digital output on X30/6 or overload of digital output on X30/7			For X30/6, check the load connected to X30/6 or remove short-circuit connection. Check [5-32] Term X30/6 Digi Out (MCB 101) . For X30/7, check the load connected to X30/77 or remove short-circuit connection. Check [5-33] Term X30/7 Digi Out (MCB 101) .
45 – Ground fault 2	Ground (earth) fault on startup.		Check for proper grounding (earthing) and loose connections. Check for proper wire size. Check motor cables for short-circuits or leakage currents.
46 – Power card supply	The supply on the power card is out of range.	There are three power supplies generated by the switch mode power supply (SMPS) on the power card: 24 V, 5 V, +/- 18 V. When powered with 24 VDC with the 24VDC Backup Option Card option, only the 24 V and 5 V supplies are monitored. When powered with three-phase mains voltage, all three supplied are monitored.	Check for a defective power cord. Check for a defective control card. Check for a defective option card. If a 24 VDC power supply is used, verify proper supply power.
47 – 24 V supply low	The 24 V DC is measured on the control card.	The external 24 V DC backup power supply may be overloaded.	Contact your Xylem supplier.

Warning/Alarm	Description	Cause	Remedy
48 – 1.8 V supply low	The power supply is measured on the control card.	The 1.8 V DC supply used on the control card is outside of allowable limits.	Check for a defective control card. If an option card is present, check for an overvoltage condition.
49 – Speed limit	When the speed is not within the specified range in [4-11] Motor Speed Low Limit [RPM] and [4-13] Motor Speed High Limit [RPM] , the frequency converter will show a warning.	When the speed is below the specified limit in [1-86] Trip Speed Low [RPM] (except when starting or stopping) the frequency converter will trip.	
50 – AMA calibration failed			Contact your Xylem supplier or Xylem Service Department.
51 – AMA check Unom and Inom	The settings for motor voltage, motor current, and motor power are wrong.		Check the settings in [1-20] to [1-25].
52 – AMA low Inom	The motor current is too low.		Check the setting in [4-18] Current Limit .
53 – AMA motor too big	The motor is too big for the AMA to operate.		
54 – AMA motor too small	The motor is too small for the AMA to operate.		
55 – AMA Parameter out of range	The parameter values of the motor are outside of the acceptable range. AMA will not run.		
56 – AMA interrupted by the user	The AMA has been interrupted by the user.		
57 – AMA timeout			Try to restart AMA again. Repeated restarts may overheat the motor.
58 – AMA internal fault			Contact your Xylem supplier.
59 – Current limit	The current is higher than the value in [4-18] Current Limit .		Ensure that motor data in [1-20] through [1-25] are set correctly. Possibly increase the current limit. Be sure that the system can operate safely at a higher limit.
60 – Pump Protect (North America)/External Interlock (International)	A digital input signal is indicating a pump protection external to the controller is active.		
62 – Output frequency at maximum limit	The output frequency has reached the value set in [4-19] Max Output Frequency .		Check the application to determine the cause. Possibly increase the output frequency. Be sure the system can operate safely at a higher output frequency. The warning will clear when the output drops below the maximum limit.
65 – Control card over temperature	The cut-out temperature of the control card is 80°C.		Check that the ambient operating temperature is within limits. Check for clogged filters. Check fan operation. Check the control card.

Warning/Alarm	Description	Cause	Remedy
66 – Heatsink temperature low	The frequency converter is too cold to operate. This warning is based on the temperature sensor in the IGBT module.		Increase the ambient temperature of the unit. A trickle amount of current can be supplied to the frequency controller whenever the motor is stopped by setting [2-00] DC Hold/Preheat Current at 5% and [1-80] Function at Stop .
67 – Option module configuration has changed	One or more options have either been added or removed since the last power down.		Check that the configuration change is intentional and reset the frequency controller.
68 – Safe stop activated	Loss of the 24 VDC signal on terminal 37 has caused the frequency controller to trip.		To resume normal operation, apply 24 VDC to terminal 37 and reset the frequency controller.
69 – Power card temperature	The temperature sensor on the power card is either too hot or too cold.		Check that the ambient operating temperature is within limits. Check for clogged filters. Check fan operation. Check the power card.
70 – Illegal FC configuration	The control card and power card are incompatible.		Contact your supplier with the typecode of the unit from the
80 – Drive initialized to default value	Parameter settings are initialized to default settings after a manual reset.		Reset the unit to clear the alarm.
92 – No flow	A no-flow condition has been detected in the system.	[22-23] No-Flow Function is set for alarm.	Troubleshoot the system and reset the frequency converter after the fault has been cleared.
93 – No Water/Loss of Prime (North America) Dry Pump (International)	A low power condition in the system with the frequency converter operating at high speed may indicate a the pump is out of water or has lost prime.	[22-26] No Water/Loss of Prime Function (North America) / Dry Pump Function (International) is set for alarm. The [22-39] No Water/Loss of Prime Limit [HP] is set too high.	Troubleshoot the system and reset the frequency converter after the fault has been cleared.
94 – Under Pressure Note: this warning/alarm is not available when the MCO301 Programmable API option card is installed and functioning.	The system pressure is below the Under Pressure limit (Under Pressure Limit = Setpoint [22-25] Under Pressure Difference).	This may indicate leakage in the system. [22-50] Under Pressure Function (North America) / End of Curve Function (International) is set for alarm.	Troubleshoot the system, and reset the frequency converter after the fault has been cleared.
95 – Broken belt	Torque is below the torque level set for no load, indicating a broken belt.	[22-60] Broken Belt Function is set for alarm.	Troubleshoot the system and reset the frequency converter after the fault has been cleared.
96 – Start delayed	Motor start has been delayed due to short-cycle protection.	[22-76] Interval Between Starts is enabled.	Troubleshoot the system and reset the frequency converter after the fault has been cleared.
97 – Stop delayed	Stopping the motor has been delayed due to short cycle protection.	[22-76] Interval Between Starts is enabled.	Troubleshoot the system and reset the frequency converter after the fault has been cleared.
98 – Clock fault	Time is not set or the RTC clock has failed.		Reset the clock in [0-70] Date and Time .
200 – Fire mode		This indicates the frequency controller is operating in fire mode.	Cycle power to the unit to remove the warning. See the fire mode data in the alarm log on the controller.

Warning/Alarm	Description	Cause	Remedy
201 – Fire mode was active	This indicates the frequency controller had entered fire mode.		Cycle power to the unit to remove the warning. See the fire mode data in the alarm log on the controller.
202 – Fire mode limits exceeded	While operating in fire mode one or more alarm conditions has been ignored which would normally trip the unit.	Operating in this condition voids unit warranty.	Cycle power to the unit to remove the warning. See the fire mode data in the alarm log on the controller.
203 – Missing motor	With a frequency converter operating multi-motors, an under-load condition was detected.	This could indicate a missing motor.	Inspect the system for proper operation.
204 – Locked rotor	With a frequency converter operating multi-motors, an overload condition was detected.	This could indicate a locked rotor.	Inspect the motor for proper operation.
250 – New spare part	A component in the frequency converter has been replaced.		Reset the frequency converter for normal operation.
251 – New typecode	A component in the frequency converter has been replaced and the typecode changed.		Reset the frequency converter for normal operation.

9 Troubleshooting

9.1 Start up and operation troubleshooting

Table 31: Troubleshooting

Symptom	Possible cause	Test	Solution
Display dark/No function	Missing or open fuses or circuit breaker tripped	See Pre-startup inspections table in this manual.	Check the input power source
	No power to the LCP	Check the LCP cable for proper connection or damage	Replace the faulty LCP or connection cable
	Shortcut on control voltage (terminal 12 or 50) or at control terminals	Check the 24 V control voltage supply for terminals 12/13 to 20-39 or 10 V supply for terminals 50 to 55	Wire the terminals properly
	Wrong LCP		Use only LCP #9K651.
	Wrong contrast setting		Press [status] + [▲]/[▼] to adjust the contrast
	Display (LCP) is defective	Test using a different LCP	Replace the faulty LCP or connection cable
	Internal voltage supply fault or SMPS is defective		Contact supplier
Intermittent display	Overloaded power supply (SMPS) due to improper control wiring or fault within the frequency converter	To rule out a problem in the control wiring, disconnect all control wiring by removing the terminal blocks.	If the display stays lit, then the problem is in the control wiring. Check the wiring for shorts or incorrect connections. If the display continues to cut out, follow the procedure for display dark.
Motor not running	Service switch open or missing motor connection	Check if the motor is connected and the connection is not interrupted (by a service switch or other device)	Connect the motor and check the service switch
	No mains power with 24 V DC option card	If the display is functioning but no output, check that mains power is applied to the frequency converter	Apply mains power to run the unit
	LCP Stop	Check if [Off] has been pressed	Press [Auto On] or [Hand On] (depending on operation mode) to run the motor
	Missing start signal (Standby)	Check 5-10 <i>Terminal 18 Digital Input</i> for correct setting for terminal 18 (use default setting)	Apply a valid start signal to start the motor
	Motor coast signal active (Coasting)	Check 5-12 <i>Coast inv.</i> for correct setting for terminal 27 (use default setting)	Apply 24 V on terminal 27 or program this terminal to No operation
	Wrong reference signal source	Check reference signals: Local, remote or bus reference? Preset reference active? Terminal connection correct? Scaling of terminals correct? Reference signal available?	Program correct settings. Check 3-13 <i>Reference Site</i> . Set preset reference active in parameter group 3-1* <i>References</i> . Check for correct wiring. Check scaling or terminals. Check reference signal.

Symptom	Possible cause	Test	Solution
Motor running in wrong direction	Motor rotation limit	Check that <i>4-10 Motor Speed Direction</i> is programmed correctly.	Program correct settings
	Active reverse signal	Check if a reversing command is programmed for the terminal in parameter group <i>5-1* Digital inputs</i> .	Deactivate reversing signal
	Wrong motor phase connection		
Motor is not reaching maximum speed	Frequency limits set wrong	Check output limits in <i>4-13 Motor Speed High Limit [RPM]</i> , <i>4-14 Motor Speed High Limit [Hz]</i> and <i>4-19 Max Output Frequency</i> .	Program correct limits
	Reference input signal not scaled correctly	Check references input signal scaling in <i>6-0* Analog I/O Mode</i> and parameter group <i>3-1* References</i> . Reference limits in parameter group <i>3-0* Reference Limit</i> .	Program correct settings
Motor speed unstable	Possible incorrect parameter settings	Check the settings of all motor parameters, including all motor compensation settings. For closed loop operation, check PID settings.	Check settings in parameter group <i>1-6* Analog I/O mode</i> .
Motor runs rough	Possible over-magnetization	Check for incorrect motor settings in all parameters	Check motor settings in parameter groups <i>1-2* Motor Data</i> , <i>1-3* Adv Motor Data</i> , and <i>1-5* Load Indep. Setting</i> .
Motor will not brake	Possible incorrect settings in the brake parameters. Possible too short ramp down times	Check brake parameters. Check ramp time settings	Check parameter group <i>2-0* DC Brake</i> and <i>3-0* Reference Limits</i> .
Open power fuses or circuit breaker trip	Phase to phase short	Motor or panel has a short phase to phase. Check motor and panel phase for shorts	Eliminate any shorts detected
	Motor overload	Motor is overloaded for the application	Perform startup test and verify motor current is within specifications. If motor current is exceeding nameplate full load current, motor may run only with reduced load. Review the specifications for the application.
	Loose connections	perform pre-startup check for loose connections	Tighten loose connections
Input current imbalance greater than 3% (not applicable for single phase drives)	Problem with mains power (see Alarm 4 input phase loss description in the Warnings and Alarms table)	Rotate input power leads into the frequency converter one position A to B, B to C to A.	If imbalanced leg follows the wire, it is a power problem. Check mains power supply.
	Problem with the frequency converter	Rotate input power leads into the frequency converter one position: A to B, B to C, C to A	If imbalance leg stays on same input terminal, it is a problem with the unit. Contact the supplier.
Motor current imbalance greater than 3%	Problem with motor or motor wiring	Rotate output motor leads one position: U to V, V to W, W to U.	If imbalanced leg follows the wire, the problem is in the motor or motor wiring. Check motor and motor wiring.
	Problem with the frequency converters	Rotate output motor leads one position: U to V, V to W, W to U.	If imbalance leg stays on same output terminal, it is a problem with the unit. Contact the supplier.

Symptom	Possible cause	Test	Solution
Acoustic noise or vibration (for example, a pump impeller blade makes noise or vibrations at certain frequencies)	Resonances, for example, in the motor/pump system	Bypass critical frequencies by using parameters in parameter group 4-6* <i>Speed Bypass</i>	Check if noise and/or vibration have been reduced to an acceptable limit
		Turn off over-modulation in 14-03 <i>Overmodulation</i>	
		Change switching pattern and frequency in parameter group 14-0* <i>Inverter Switching</i>	
		Increase Resonance Dampening in 1-64 <i>Resonance Dampening</i>	

10 Technical Specification

10.1 Power-dependent specifications

Table 32: Mains supply 1 x 200-240 V AC

Frequency Converter Type Designation	0015	0020	0030	0050	0075	0010	0200	0300
Typical shaft output [kW]	1.1	1.5	2.2	3.7	5.5	7.5	15	22
Typical shaft output at 240 V [hp]	1.5	2.0	2.9	4.9	7.5	10	20	30
IP20/Chassis ⁶⁾	A3	–	–	–	–	–	–	–
IP21/Type 1	–	B1	B1	B1	B1	B2	C1	C2
IP55/Type 3R/12 ¹¹⁾	A5	B1	B1	B1	B1	B2	C1	C2
IP66/Type 4X	A5	B1	B1	B1	B1	B2	C1	C2
Output current								
Continuous (3x200–240 V) [A]	6.6	7.5	10.6	16.7	24.2	30.8	59.4	88
Intermittent (3x200–240 V) [A]	7.3	8.3	11.7	18.4	26.6	33.4	65.3	96.8
Continuous kVA at 208 V [kVA]	2.4	2.7	3.8	6.0	8.7	11.1	21.4	31.7
Maximum input current								
Continuous (1x200–240 V) [A]	12.5	15	20.5	32	46	59	111	172
Intermittent (1x200–240 V) [A]	13.8	16.5	22.6	35.2	50.6	64.9	122.1	189.2
Maximum pre-fuses [A]	20	30	40	60	80	100	150	200
Additional specifications								
Maximum cable size (motor, brake) [mm ² (AWG) ³⁾ 2)	2.5–6 (14–10)	4–6 (12–10)			10 (8)	35 (2)	50 (1/0)	95 (4/0)
Maximum cable size ²⁾ for mains with disconnect switch [mm ² (AWG) ³⁾ 2)	16 (6)					25 (3)	50 (1/0)	2x50 (2x1/0) 9)10)
Maximum cable size for mains without disconnect switch [mm ² (AWG) ³⁾ 2)	16 (6)					25 (3)	50 (1/0)	95 (4/0)
Cable insulation temperature rating [Degrees Celsius]	75							
Estimated power loss ⁵⁾ at rated maximum load [W]	44	30	44	74	110	150	300	440
Efficiency ⁴⁾	0.98	0.98	0.98	0.98	0.98	0.98	0.98	0.98

Table 33: Mains supply 1 x 380–480 V AC

Frequency Converter Type Designation	0100	0150	0250	0500
Typical shaft output [kW]	7.5	11	18.5	37
Typical shaft output at 480 V [hp]	10	15	25	50
IP21/Type 1	B1	B2	C1	C2
IP55/Type 3R/12 ¹¹⁾	B1	B2	C1	C2
IP66/Type 4X	B1	B2	C1	C2
Output current				
Continuous (3x380–440 V) [A]	16	24	37.5	73
Intermittent (3x380–440 V) [A]	17.6	26.4	41.2	80.3
Continuous (3x441–480 V) [A]	14.5	21	34	65
Intermittent (3x441–480 V) [A]	15.4	23.1	37.4	71.5
Continuous kVA at 400 V [kVA]	11.0	16.6	26	50.6

Frequency Converter Type Designation	0100	0150	0250	0500
Continuous kVA at 460 V [kVA]	11.6	16.7	27.1	51.8
Maximum input current				
Continuous (1x380–440 V) [A]	33	48	78	151
Intermittent (1x380–440 V) [A]	36	53	85.5	166
Continuous (1x441–480 V) [A]	30	41	72	135
Intermittent (1x441–480 V) [A]	33	46	79.2	148
Maximum pre-fuses [A]	63	80	160	250
Additional specifications				
Maximum cable size for mains, motor, and brake [mm ² (AWG) ³⁾ 2)	10 (8)	35 (2)	50 (1/0)	120 (4/0)
Estimated power loss ⁵⁾ at rated maximum load [W]	300	440	740	1480
Efficiency ⁴⁾	0.96	0.96	0.96	0.96

Table 34: Mains supply 3 x 200-240 V AC – Normal overload 110% for 1 minute, 1.5HP - 5HP

Frequency Converter Type Designation	0015	0020	0030	0050
Typical shaft output [HP]	1.5	2	3	5
IP20/chassis ⁶⁾	A2	A2	A2	A3
IP55/Type 3R/12 ¹¹⁾	A4/A5	A4/A5	A4/A5	A5
IP66/Type 4X	A4/A5	A4/A5	A4/A5	A5
Typical shaft output [HP] at 208 V	1.5	2.0	2.9	4.9
Output current				
Continuous (3 x 200–240 V) [A]	6.6	7.5	10.6	16.7
Intermittent (3 x 200–240 V) [A]	7.3	8.3	11.7	18.4
Continuous kVA (208 V AC) [A]	2.38	2.70	3.82	6.00
Maximum input current				
Continuous (3 x 200–240 V) [A]	5.9	6.8	9.5	15.0
Intermittent (3 x 200–240 V) [A]	6.5	7.5	10.5	16.5
Additional specifications				
Estimated power loss at rated maximum load [W] ⁵⁾	63	82	116	185
IP20/Chassis, IP21/Type 1 maximum cable size ⁸⁾ (mains, motor, brake, and load sharing) [mm ² (AWG) ³⁾ ²⁾	4, 4, 4 (12, 12, 12)			
IP55/Type 3R/12, IP66/Type 4X maximum cable size ⁸⁾ (mains, motor, brake, and load sharing) [mm ² (AWG) ³⁾ ²⁾	4, 4, 4 (12, 12, 12)			
Maximum cable size with disconnect ⁸⁾ [mm ² (AWG) ³⁾ ²⁾	6, 4, 4 (10, 12, 12)			
Efficiency ⁴⁾	0.96	0.96	0.96	0.96

Table 35: Mains supply 3 x 200-240 V AC – Normal overload 110% for 1 minute, 7.5HP - 25HP

Frequency Converter Type Designation	0075	0100	0150	0200	0250
IP20/chassis ⁷⁾	B3	B3	B3	B4	B4
IP21/Type 1	B1	B1	B1	B2	C1
IP55/Type 3R/12 ¹¹⁾	B1	B1	B1	B2	C1
IP66/Type 4X	B1	B1	B1	B2	C1
Typical shaft output [HP]	7.5	10	15	20	25
Typical shaft output [HP] at 208 V	7.5	10	15	20	25
Output current					

Frequency Converter Type Designation	0075	0100	0150	0200	0250
Continuous (3 x 200-240 V) [A]	24.2	30.8	46.2	59.4	74.8
Intermittent (3 x 200-240 V) [A]	26.6	33.9	50.8	65.3	82.3
Continuous KVA (208 V VA) [kVA]	8.7	11.1	16.6	21.4	26.9
Maximum input current					
Continuous (3 x 200-240 V) [A]	22.0	28.0	42.0	54.0	68.0
Intermittent (3 x 200-240 V) [A]	24.2	30.8	46.2	59.4	74.8
Additional specifications					
Estimated power loss at rated maximum load [W] ⁵⁾	269	310	447	602	737
IP20/Chassis maximum cable size ⁸⁾ (mains, brake, motor, and load sharing) [mm ² (AWG) ³⁾] ²⁾	10, 10 (8, 8-)		35, 25, 25 (2, 4, 4)	35 (2)	50 (1)
IP21/Type 1, IP55/Type 3R/12, IP66/Type 4X maximum cable size ⁸⁾ (mains, motor) [mm ² (AWG) ³⁾] ²⁾	10, 10 (8, 8-)		35, 25, 25 (2, 4, 4)	50 (1)	
IP21/Type 1, IP55/Type 3R/12, IP66/Type 4X maximum cable size ⁸⁾ (brake, load sharing) [mm ² (AWG) ³⁾] ²⁾	16, 10, 16 (6, 8, 6)		35, 25, 25 (2, 4, 4)	50 (1)	
Efficiency ⁴⁾	0.96	0.96	0.96	0.96	0.96

Table 36: Mains supply 3 x 200-240 V AC – Normal overload 110% for 1 minute, 30HP - 60HP

Frequency Converter Type Designation	0300	0400	0500	0600
IP20/chassis ⁷⁾	C3	C3	C4	C4
IP21/Type 1	C1	C1	C2	C2
IP55/Type 3R/12 ¹¹⁾	C1	C1	C2	C2
IP66/Type 4X	C1	C1	C2	C2
Typical shaft output [HP]	30	40	50	60
Typical shaft output [HP] at 208 V	30	40	50	60
Output current				
Continuous (3 x 200-240 V) [A]	88.0	115	143	170
Intermittent (3 x 200-240 V) [A]	96.8	127	157	187
Continuous KVA (208 V AC) [kVA]	31.7	41.4	51.5	61.2
Maximum input current				
Continuous (3 x 200-240 V) [A]	80.0	104.0	130.0	154.0
Intermittent (3 x 200-240 V) [A]	88.0	114.0	143.0	169.0
Additional specifications				
Estimated power loss at rated maximum load [W] ⁵⁾	845	1140	1353	1636
IP20/Chassis maximum cable size ⁸⁾ (mains, brake, motor, and load sharing) [mm ² (AWG) ³⁾] ²⁾	50 (1)	150 (300 mcm)		
IP21/Type 1, IP55/Type 3R/12, IP66/Type 4X maximum cable size ⁸⁾ (mains, motor) [mm ² (AWG) ³⁾] ²⁾	50 (1)	150 (300 mcm)		
IP21/Type 1, IP55/Type 3R/12, IP66/Type 4X maximum cable size ⁸⁾ (brake, load sharing) [mm ² (AWG) ³⁾] ²⁾	50 (1)	95 (3/0)		
Efficiency ⁴⁾	0.97	0.97	0.97	0.97

Table 37: Mains supply 3 x 380-480 V AC – Normal overload 110% for 1 minute, 1.5HP - 10HP

Frequency Converter Type Designation	0015	0020	0030	0050	0075	0100
Typical shaft output [HP]	1.5	2	3	5	7.5	10
Typical shaft output [HP] at 460 V	1.5	2.0	2.9	5.0	7.5	10
IP20/Chassis ⁶⁾	A2	A2	A2	A2	A3	A3

Frequency Converter Type Designation	0015	0020	0030	0050	0075	0100
IP55/Type 3R/12 ¹¹⁾	A4/A5	A4/A5	A4/A5	A4/A5	A5	A5
IP66/Type 4X	A4/A5	A4/A5	A4/A5	A4/A5	A5	A5
Output current						
Continuous (3 x 380–440 V) [A]	3	4.1	5.6	10	13	16
Intermittent (3 x 380–440 V) [A]	3.3	4.5	6.2	11	14.3	17.6
Continuous (3 x 441–480 V) [A]	2.7	3.4	4.8	8.2	11	14.5
Intermittent (3 x 441–480 V) [A]	3.0	3.7	5.3	9.0	12.1	15.4
Continuous kVA (400 V AC) [kVA]	2.1	2.8	3.9	6.9	9.0	11.0
Continuous kVA (460 V AC) [kVA]	2.4	2.7	3.8	6.5	8.8	11.6
Maximum input current						
Continuous (3 x 380–440 V) [A]	2.7	3.7	5.0	9.0	11.7	14.4
Intermittent (3 x 380–440 V) [A]	3.0	4.1	5.5	9.9	12.9	15.8
Continuous (3 x 441–480 V) [A]	2.7	3.1	4.3	7.4	9.9	13.0
Intermittent (3 x 441–480 V) [A]	3.0	3.4	4.7	8.1	10.9	14.3
Additional specifications						
Estimated power loss at rated maximum load [W] ⁵⁾	58	62	88	124	187	255
IP20/Chassis, IP21/Type 1 maximum cable size ⁸⁾ (mains, motor, brake, and load sharing) [mm ² (AWG) ³⁾] ²⁾	4, 4, 4 (12, 12, 12)					
IP55/Type 3R/12, IP66/Type 4X maximum cable size ⁸⁾ (mains, motor, brake, and load sharing) [mm ² (AWG) ³⁾] ²⁾	4, 4, 4 (12, 12, 12)					
Maximum cable size ⁸⁾ with disconnect [mm ² (AWG) ³⁾] ²⁾	6, 4, 4 (10, 12, 12)					
Efficiency ⁴⁾	0.96	0.97	0.97	0.97	0.97	0.97

Table 38: Mains supply 3 x 380–480 V AC – Normal overload 110% for 1 minute, 15HP - 40HP

Frequency Converter Type Designation	0150	0200	0250	0300	0400
Typical shaft output [HP]	15	20	25	30	40
Typical shaft output [HP] at 460 V	15	20	25	30	40
IP20/chassis ⁷⁾	B3	B3	B3	B4	B4
IP21/Type 1	B1	B1	B1	B2	B2
IP55/Type 3R/12 ¹¹⁾	B1	B1	B1	B2	B2
IP66/Type 4X	B1	B1	B1	B2	B2
Output current					
Continuous (3 x 380–439 V) [A]	24	32	37.5	44	61
Intermittent (3 x 380–439 V) [A]	26.4	35.2	41.3	48.4	67.1
Continuous (3 x 440–480 V) [A]	21	27	34	40	52
Intermittent (3 x 440–480 V) [A]	23.1	29.7	37.4	44	61.6
Continuous kVA (400 V AC) [kVA]	16.6	22.2	26	30.5	42.3
Continuous kVA (460 V AC) [kVA]	16.7	21.5	27.1	31.9	41.4
Maximum input current					
Continuous (3 x 380–439 V) [A]	22	29	34	40	55
Intermittent (3 x 380–439 V) [A]	24.2	31.9	37.4	44	60.5
Continuous (3 x 440–480 V) [A]	19	25	31	36	47
Intermittent (3 x 440–480 V) [A]	20.9	27.5	34.1	39.6	51.7
Additional specifications					
Estimated power loss at rated maximum load [W] ⁵⁾	278	392	465	525	698

Frequency Converter Type Designation	0150	0200	0250	0300	0400
IP20/Chassis maximum cable size ⁸⁾ (mains, motor, and load sharing) [mm ² (AWG) ³⁾] ²⁾	16, 10,- (8, 8,-)		35,-,- (2,-,-)		35 (2)
IP21/Type 1, IP55/Type 3R/12, IP66/Type 4X maximum cable size ⁸⁾ (mains, motor) [mm ² (AWG) ³⁾] ²⁾	10, 10, 16 (6, 8, 6)		35, 25, 25 (2, 4, 4)		50 (1)
IP21/Type 1, IP55/Type 3R/12, IP66/Type 4X maximum cable size ⁸⁾ (brake, load sharing) [mm ² (AWG) ³⁾] ²⁾	10, 10,- (8, 8,-)		35,-,- (2,-,-)		50 (1)
With mains disconnect switch included [mm ² (AWG) ³⁾] ²⁾	16 (6)				
Efficiency ⁴⁾	0.98	0.98	0.98	0.98	0.98

Table 39: Mains supply 3 x 380–480 V AC – Normal overload 110% for 1 minute, 50HP - 125HP

Frequency Converter Type Designation	0500	0600	0750	1000	1250
Typical shaft output [HP]	50	60	75	100	125
Typical shaft output [HP] at 460 V	50	60	75	100	125
IP20/Chassis ⁷⁾	B4	C3	C3	C4	C4
IP21/Type 1	C1	C1	C1	C2	C2
IP55/Type 3R/12 ¹¹⁾	C1	C1	C1	C2	C2
IP66/Type 4X	C1	C1	C1	C2	C2
Output current					
Continuous (3 x 380–439 V) [A]	73	90	106	147	177
Intermittent (3 x 380–439 V) [A]	80.3	99	117	162	195
Continuous (3 x 440–480 V) [A]	65	80	105	130	160
Intermittent (3 x 440–480 V) [A]	71.5	88	116	143	176
Continuous kVA (400 V AC) [kVA]	50.6	62.4	73.4	102	123
Continuous kVA (460 V AC) [kVA]	51.8	63.7	83.7	104	128
Maximum input current					
Continuous (3 x 380–439 V) [A]	66	82	96	133	161
Intermittent (3 x 380–439 V) [A]	72.6	90.2	106	146	177
Continuous (3 x 440–480 V) [A]	59	73	95	118	145
Intermittent (3 x 440–480 V) [A]	64.9	80.3	105	130	160
Additional specifications					
Estimated power loss at rated maximum load [A] ⁵⁾	739	843	1083	1384	1474
IP20/Chassis maximum cable size (mains, brake, motor, and load sharing) [mm ² (AWG) ³⁾] ²⁾	50 (1)		150 (300 MCM)		
IP21/Type 1, IP55/Type 3R/12, IP66/Type 4X maximum cable size (mains, motor) [mm ² (AWG) ³⁾] ²⁾	50 (1)		150 (300 MCM)		
IP21/Type 1, IP55/Type 3R/12, IP66/Type 4X maximum cable size (brake, load sharing) [mm ² (AWG) ³⁾] ²⁾	50 (1)		95 (3/0)		
With mains disconnect switch included [mm ² (AWG) ³⁾] ²⁾	35 (2)	35 (2)	35 (2)	70 (2/0)	185 (350 kcmil)
Efficiency ⁴⁾	0.98	0.98	0.98	0.98	0.98

Table 40: Mains supply 3 x 525–600 V AC Normal overload 110% for 1 minute, 1.5HP - 15HP

Frequency Converter Type Designation	0015	0020	0030	0050	0075	0100	0150
Typical shaft output [HP]	1.5	2	3	5	7.5	10	15
IP20/Chassis ^{6/7)}	A3	A3	A3	A3	A3	A3	B3
IP21/Type 1	A3	A3	A3	A3	A3	A3	B1

Frequency Converter Type Designation	0015	0020	0030	0050	0075	0100	0150
IP55/Type 3R/12 ¹¹⁾	A5	A5	A5	A5	A5	A5	B1
IP66/Type 4X	A5	A5	A5	A5	A5	A5	B1
Output current							
Continuous (3 x 525–550 V) [A]	2.6	2.9	4.1	6.4	9.5	11.5	19
Intermittent (3 x 525–550 V) [A]	2.9	3.2	4.5	7.0	10.5	12.7	21
Continuous (3 x 525–600 V) [A]	2.4	2.7	3.9	6.1	9.0	11.0	18
Intermittent (3 x 525–600 V) [A]	2.6	3.0	4.3	6.7	9.9	12.1	20
Continuous kVA (525 V AC) [kVA]	2.5	2.8	3.9	6.1	9.0	11.0	18.1
Continuous kVA (575 V AC) [kVA]	2.4	2.7	3.9	6.1	9.0	11.0	17.9
Maximum input current							
Continuous (3 x 525–600 V) [A]	2.4	2.7	4.1	5.8	8.6	10.4	17.2
Intermittent (3 x 525–600 V) [A]	2.7	3.0	4.5	6.4	9.5	11.5	19
Additional specifications							
Estimated power loss at rated maximum load [W] ⁵⁾	50	65	92	145	195	261	300
IP20/Chassis maximum cable size ⁸⁾ (mains, motor, brake, and load sharing) [mm ² (AWG) ³⁾ 2)	4, 4, 4 (12, 12, 12)						10, 10, - (8, 8, -)
IP21/Type 1, IP55/Type 3R/12, IP66/Type 4X maximum cable size ⁸⁾ (mains, motor, brake, and load sharing) [mm ² (AWG) ³⁾ 2)	4, 4, 4 (12, 12, 12)						10, 10, - (8, 8, -)
Maximum cable size ⁸⁾ with disconnect [mm ² (AWG) ³⁾ 2)	6, 4, 4 (12, 12, 12)						10, 10, - (8, 8, -)
Mains disconnect switch included [mm ² (AWG) ³⁾ 2):	4 (12)						
Efficiency ⁴⁾	0.97	0.97	0.97	0.97	0.97	0.97	0.98

Table 41: Mains supply 3 x 525–600 V AC Normal overload 110% for 1 minute, 20HP - 125HP

Frequency Converter Type Designation	0200	0250	0300	0400	0500	0600	0750	1000	1250
Typical shaft output [HP]	20	25	30	40	50	60	75	100	125
IP20/Chassis	B3	B3	B4	B4	B4	C3	C3	C4	C4
IP21/Type 1	B1	B1	B2	B2	C1	C1	C1	C2	C2
IP55/Type 3R/12 ¹¹⁾	B1	B1	B2	B2	C1	C1	C1	C2	C2
IP66/Type 4X	B1	B1	B2	B2	C1	C1	C1	C2	C2
Output current									
Continuous (3 x 525–550 V) [A]	23	28	36	43	54	65	87	105	137
Intermittent (3 x 525–550 V) [A]	25	31	40	47	59	72	96	116	151
Continuous (3 x 525–600 V) [A]	22	27	34	41	52	62	83	100	131
Intermittent (3 x 525–600 V) [A]	24	30	37	45	57	68	91	110	144
Continuous kVA (525 V AC) [kVA]	21.9	26.7	34.3	41	51.4	61.9	82.9	100	130.5
Continuous kVA (575 V AC) [kVA]	21.9	26.9	33.9	40.8	51.8	61.7	82.7	99.6	130.5
Maximum input current									
Continuous (3 x 525–600 V) [A]	20.9	25.4	32.7	39	49	59	78.9	95.3	124.3
Intermittent (3 x 525–600 V) [A]	23	28	36	43	54	65	87	105	137
Additional specifications									
Estimated power loss at rated maximum load [W] ⁵⁾	400	475	525	700	750	850	1100	1400	1500
IP20/Chassis maximum cable size ⁸⁾ (mains, motor, brake, and load sharing) [mm ² (AWG) ³⁾ 2)	10, 10, - (8, 8, -)	35, -, - (2, -, -)			50, -, - (1, -, -)		150 (300 MCM)		

Frequency Converter Type Designation	0200	0250	0300	0400	0500	0600	0750	1000	1250
IP55/Type 3R/12, IP66/Type 4X maximum cable size ⁸⁾ (mains, motor, brake, and load sharing) [mm ² (AWG) ³⁾] ²⁾	16, 10, 10 (6, 8, 8)	35, - (2, -)		50, - (1, -)			95 (4/0)		
Maximum cable size ⁸⁾ with disconnect [mm ² (AWG) ³⁾] ²⁾	16, 10, 10 (6, 8, 8)			50, 35, 35 (1, 2, 2)			95, 70, 70 (3/0, 2/0, 2/0)	185, 150, 120 (350 MCM, 300 MCM, 4/0)	
Mains disconnect switch included [mm ² (AWG) ³⁾] ²⁾	16 (6)				35 (2)			70 (3/0)	185 (kcmil 350)
Efficiency ⁴⁾	0.98	0.98	0.98	0.98	0.98	0.98	0.98	0.98	0.98

2) For type of fuse, see Fuse Specifications

3) American Wire Gauge

4) Measured using 5 m screened motor cables at rated load and rated frequency

5) The typical power loss at normal load conditions and expected to be within $\pm 15\%$ (tolerance relates to variety in voltage and cable conditions).

- Values are based on a typical motor efficiency (eff2/eff3 border line). Lower efficiency motor will also add to the power loss in the frequency converter and vice versa.
- If the switch frequency is raised from nominal the power losses may rise significantly.
- LCP and typical control card power consumptions are included. Further options and customer load may add up to 30 W to the losses. (Though typically only 4 W extra for a fully loaded control card or options for slot A or slot B, each)
- Although measurements are made with state of the art equipment, some measurement inaccuracy must be allowed for ($\pm 5\%$).

6) A2+A3 may be converted to IP21 using a conversion kit. (See Pricebook for conversion kit order numbers.)

7) B3+B4 and C3+C4 may be converted to IP21 using a conversion kit. (See Pricebook for conversion kit order numbers.)

8) The three values for the max. cable cross-section are for single core, flexible wire and flexible wire with sleeve, respectively.

9) Two wires are required

10) Variant not available in IP21

11) UL Type 3R is not available in A4 frame size

10.2 General technical data

Mains supply

Supply terminals	L1, L2, L3
Supply voltage	200-240 V $\pm 10\%$
Supply voltage	380-480 V/525-600 V $\pm 10\%$
Supply voltage	525-690 V $\pm 10\%$

Mains voltage low/mains drop-out: During low mains voltage or a mains drop-out, the drive continues until the intermediate circuit voltage drops below the minimum stop level, which corresponds typically to 15% below the frequency converter's lowest rated supply voltage. Power-up and full torque cannot be expected at mains voltage lower than 10% below the frequency converter's lowest rated supply voltage.

Supply frequency 50/60 Hz $\pm 5\%$

Maximum imbalance temporary between mains phases	3.0% of rated supply voltage
True power factor (λ)	≥ 0.9 nominal rated load
Displacement Power Factor ($\cos \phi$)	near unity (> 0.98)
Switching on input supply L1, L2, L3 (power-ups) ≥ 10 hp	maximum 2 times/minute
Switching on input supply L1, L2, L3 (power-ups) 15-100 hp	maximum 1 time/minute
Switching on input supply L1, L2, L3 (power-ups) ≥ 125 hp	maximum 1 time/2 minutes
Environment according to EN60664-1	overvoltage category III/pollutin degree 2

The unit is suitable for use on a circuit capable of delivering not more than 100,000 RMS symmetrical Amperes, 240/500/600/690 V maximum.

Motor output (U, V, W)

Output voltage	0-100% of supply voltage
Output frequency	0-590 Hz
Output frequency (110-250 kW)	0-590 ¹⁾ Hz
Switching on output	Unlimited
Ramp times	1-3600 s

¹⁾ Voltage and power dependent

Torque characteristics

Starting torque (constant torque)	maximum 110% for 60 s ¹⁾
Starting torque	maximum 135% up to 0.5 s ¹⁾
Overload torque (constant torque)	maximum 110% for 60 s ¹⁾
Starting torque (variable torque)	maximum 110% for 60 s ¹⁾
Overload torque (variable torque)	maximum 110% for 60 s
Torque rise time in VVCP ^{plus} (independent of fsw)	10 ms

¹⁾ Percentage relates to the nominal torque.

²⁾ The torque response time depends on application and load but as a general rule, the torque step from 0 to reference is 4-5 x torque rise time.

Cable lengths and cross sections for control cables¹⁾

Maximum motor cable length, screened	492 ft (150m)
Maximum motor cable length, unscreened	984 ft (300m)
Maximum cross-section to control terminals, flexible/rigid wire without cable end-sleeves	0.0023 in ² (1.5 mm ²)/16 AWG (2x0.75 mm ²)
Maximum cross-section to control terminals, flexible wire with cable end-sleeves	0.0016 in ² (1 mm ²)/18 AWG
Maximum cross-section to control terminals, flexible wire with cable end-sleeves with collar	.0008 in ² (0.5 mm ²)/20 AWG
Maximum cross section to control terminals	0.00039 in ² (0.25 mm ²)

¹⁾ For power cables, see Power Dependent Specifications.

Digital inputs

Programmable digital inputs	4 (6) ¹⁾
Terminal number	18, 19, 27 ¹⁾ , 29 ¹⁾ , 32, 33

Logic	PNP or NPN
Voltage level	0-24 V DC
Voltage level, logic '0' PNP	<5 V DC
Voltage level I, logic '1' PNP	>10 V DC
Voltage level, logic '0' NPN ²⁾	>19 V DC
Voltage level, logic '1' NPN ²⁾	<14 V DC
Maximum voltage on input	28 V DC
Pulse frequency range	0-110 kHz
(Duty cycle) Min. pulse width	4.5 ms
Input resistance, Ri	Approximately 4 k Ω

Analog inputs

Number of analog inputs	2
Terminal number	53, 54
Modes	Voltage or current
Mode select	Switches A53 and A54
Voltage mode	Switch A54 = U (left position)
Voltage level	0 V to 10 V (scaleable)
Input resistance Ri	Approximately 10 k Ω
Maximum voltage	± 20 V
Current mode	Switch A53 = I (fixed); A54 = I (right position)
Current level	0/4 to 20 mA (scaleable)
Input resistance Ri	Approximately 200 Ω
Maximum current	30 mA
Resolution for analog inputs	10 bit (+ sign)
Accuracy of analog inputs	Maximum error 0.5% of full scale
Bandwidth	20 Hz/100 Hz

The analog inputs are galvanically isolated from the supply voltage (PELV) and other high-voltage terminals.

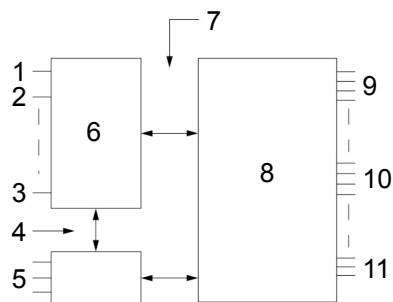

1. +24 V
2. 18
3. 37
4. Functional isolation
5. RS485
6. Control
7. PELV isolation
8. High voltage
9. Mains
10. Motor
11. DC-Bus

Figure 49: PELV isolation

Pulse

Programmable pulse	2/1
Terminal number pulse	29 ¹⁾ , 33 ²⁾ / 33 ³⁾
Maximum frequency at terminal 29, 33	110 kHz (push-pull driven)
Maximum frequency at terminal 29, 33	5 kHz (open collector)
Minimum frequency at terminal 29, 33	4 Hz
Voltage level	See Digital Inputs in the General Technical Data section.
Maximum voltage on input	28 V DC
Input resistance, Ri	Approximately 4k Ω
Pulse input accuracy (0.1-1 kHz)	Maximum error: 0.1% of full scale
Encoder input accuracy (1-11 kHz)	Maximum error: 0.05% of full scale

The pulse and encoder inputs (terminals 29, 32, 33) are galvanically isolated from the supply voltage (PELV) and other high-voltage terminals.

¹⁾ only

²⁾ Pulse inputs are 29 and 33

Analog output

Number of programmable analog outputs	1
Terminal number	42
Current range at analog output	0/4-20 mA
Maximum load GND – analog output	500 Ω
Accuracy on analog output	Maximum error: 0.5% of full scale
Resolution on analog output	12 bit

The analog output is galvanically isolated from the supply voltage (PELV) and other high-voltage terminals.

Control card, RS-485 serial communication

Terminal number	68 (P, TX+, RX+), 69 (N, TX-, RX-)
Terminal number 61	Common for terminals 68 and 69

The RS-485 serial communication circuit is functionally separated from other central circuits and galvanically isolated from the supply-voltage (PELV).

Digital output

Programmable digital/pulse outputs	2
Terminal number	27, 29 ¹⁾
Voltage level at digital/frequency output	0-24 V
Maximum output current (sink or source)	40 mA
Maximum load at frequency output	1 k Ω
Maximum capacitive load at frequency output	10 nF
Minimum output frequency at frequency output	0 Hz
Maximum output frequency at frequency output	32 kHz
Accuracy of frequency output	Maximum error: 0.1% of full scale
Resolution of frequency outputs	12 bit

The digital output is galvanically isolated from the supply voltage (PELV) and other high-voltage terminals.

¹⁾ Terminal 27 and 29 can also be programmed as input.

Control card, 24 V DC output

Terminal number	12, 13
Output voltage	24 V +1, 3 V
Maximum load	200 mA

The 24 V DC supply is galvanically isolated from the supply voltage (PELV), but has the same potential as the analog and digital inputs and outputs.

Relay outputs

Programmable relay outputs	all kW: 2
Relay 01 terminal number	13 (break), 12 (make)
Maximum terminal load (AC-1) ¹⁾ on 13 (NC), 12 (NO) (resistive load)	240 V AC, 2 A
Maximum terminal load (AC-15) ¹⁾ (inductive load @ $\cos\phi$ 0.4)	240 V AC, 0.2 A
Maximum terminal load (DC-1) ¹⁾ on 12 (NO), 13 (NC) (resistive load)	60 V DC, 1 A
Maximum terminal load (DC-13) ¹⁾ (inductive load)	24 V DC, 0.1 A
Relay 02 (only) terminal number	4-6 (break), 4-5 (make)
Maximum terminal load (AC-1) ¹⁾ on 45 (NO) (resistive load) ²⁾³⁾ overvoltage category II	400 V AC, 2 A
Maximum terminal load (AC-15) ¹⁾ on 45 (NO) (inductive load @ $\cos\phi$ 0.4)	240 V AC, 0.2 A
Maximum terminal load (DC-1) ¹⁾ on 45 (NO) (resistive load)	80 V DC, 2 A
Maximum terminal load (DC-13) ¹⁾ on 45 (NO) (inductive load)	24 V DC, 0.1 A
Maximum terminal load (AC-1) ¹⁾ on 46 (NC) (resistive load)	240 V AC, 2 A
Maximum terminal load (AC-15) ¹⁾ on 46 (NC) (inductive load @ $\cos\phi$ 0.4)	240 V AC, 0.2 A
Maximum terminal load (DC-1) ¹⁾ on 46 (NC) (resistive load)	50 V DC, 2 A
Maximum terminal load (DC-13) ¹⁾ on 46 (NC) (inductive load)	24 V DC, 0.1 A
Minimum terminal load on 13 (NC), 12 (NO), 46 (NC), 45 (NO)	24 V DC 10 mA, 24 V AC 20 mA
Environment according to EN 60664-1	overvoltage category III/pollution degree 2

¹⁾ IEC 60947 part 4 and 5

The relay contacts are galvanically isolated from the rest of the circuit by reinforced isolation (PELV).

²⁾ Overvoltage category II

³⁾ UL applications 300 V AC 2A

Control card, 10 V DC output

Terminal number	50
Output voltage	10.5 V \pm 0.5 V
Maximum load	15 mA

The 10 V DC supply is galvanically isolated from the supply voltage (PELV) and other high-voltage terminals.

Control characteristics

Resolution of output frequency at 0–590 Hz	± 0.003 Hz
Repeat accuracy of Precise start/stop (terminals 18, 19)	≤ ± 0.1 ms
System response time (terminals 18, 19, 27, 29, 32, 33)	≤ 2 ms
Speed control range (open loop)	1:100 of synchronous speed
Speed control range (closed loop)	1:1000 of synchronous speed
Speed accuracy (open loop)	30–4000 rpm: error ±8 rpm
Speed accuracy (closed loop), depending on resolution of feedback device	0–6000 rpm: error ±0.15 rpm

All control characteristics are based on a 4-pole asynchronous motor

Environment

Enclosure IP Rating	IP20/Chassis, IP21/Type 1, IP55/Type 3R/12, IP66/Type 4X
Vibration test	1.0 g
Maximum relative humidity	5% - 93% (IEC 72133) Class 3K3 (non-condensing) during operation
Aggressive environment (IEC 60068243) H ₂ S test	class Kd
Ambient temperature ³⁾	Maximum 50°C (24hour average maximum 45°C)
Minimum ambient temperature during full-scale operation	0°C
Minimum ambient temperature at reduced performance	10°C
Temperature during storage/transport	25 to +65/70°C
Maximum altitude above sea level without derating	1000 m
EMC standards, Emission	EN 61800-3, EN 61000-6-3/4, EN 55011
EMC standards, immunity	EN 61800-3, EN 61000-6-1/2, EN 61000-4-2, EN 61000-4-3, EN 61000-4-4, EN 61000-4-5, EN 61000-4-6

Derating for high altitude, see the Technical Bulletin for detailed information.

¹⁾ Only for ≤ 3.7 kW (200240 V), ≤ 7.5 kW (400480 V)

²⁾ As enclosure kit for ≤ 3.7 kW (200240 V), ≤ 7.5 kW (400480 V)

³⁾ Derating for high ambient temperature, see the Technical Bulletin for detailed information.

Control card performance

Scan interval	1 ms
---------------	------

Control card, USB serial communication

USB standard	1.1 (full speed)
USB plug	USB type B "device" plug

Connection to PC is carried out via a standard host/device USB cable.

The USB connection is galvanically isolated from the supply voltage (PELV) and other high-voltage terminals.

The USB ground connection is not galvanically isolated from protection earth. Use only an isolated laptop as PC connection to the USB connector on the frequency converter.

Protection and features

- Electronic thermal motor protection against overload.
- Temperature monitoring of the heatsink ensures that the frequency converter trips if the temperature reaches a predefined level. An overload temperature cannot be reset until the temperature of the heatsink is below the values stated in the tables on the following pages (Guideline – these temperatures may vary for different power sizes, frame sizes, enclosure ratings, etc.)
- The frequency converter is protected against short-circuits on motor terminals U, V, W.
- If mains phase is missing, the frequency converter trips a warning (depending on the load).
- Monitoring of the intermediate circuit voltage ensures that the frequency converter trips if the intermediate circuit voltage is too low or too high.
- The frequency converter constantly checks for critical levels of internal temperature, load current, high voltage on the intermediate circuit and low motor speeds. As a response to a critical level, the frequency converter can adjust the switching frequency and/or change the switching pattern in order to ensure the performance of the frequency converter.

10.3 Fuses and circuit breakers

Use recommended fuses and/or circuit breakers on the supply side as protection in case of component breakdown inside the adjustable frequency drive (first fault).

NOTICE:

Use of fuses on the supply side is mandatory for IEC 60364 (CE) and NEC 2009 (UL) compliant installations.

Recommendations

- Fuses of the type gG
- Circuit breakers of Moeller types. For other circuit breaker types, ensure that the energy into the adjustable frequency drive is equal to or lower than the energy provided by Moeller types.

Use of recommended fuses and circuit breakers ensures possible damage to the adjustable frequency drive is limited to damages inside the unit.

The fuses below are suitable for use on a circuit capable of delivering 100,000 Ams (symmetrical), depending on the adjustable frequency drive voltage rating. With the proper fusing the adjustable frequency drive Short Circuit Current Rating (SCCR) is 100,000 Ams.

NEC (NFPA 70) Compliance

Table 42: Mains supply 1x200-240 V AC

Frequency converter	HP rating	Continuous input current (1x200-240 V AC)	NEC fuse size
0015	1.5	12.5	15
0020	2	15	20
0030	3	20.5	25
0050	5	32	40
0075	7.5	46	60
0100	10	59	80
0200	20	111	150
0300	30	172	200

Table 43: Mains supply 1x380–480 V AC

Frequency converter	HP rating	Continuous input current (1x441–480 V AC)	NEC fuse size
0100	10	30	40
0150	15	41	60
0250	25	72	90
0500	50	135	175

Table 44: Line power supply 3x200–240 V AC

Frequency converter	HP rating	Continuous input current (3x300–240 V AC)	NEC fuse size
0015	1.5	5.9	10
0020	2	6.8	10
0030	3	9.5	15
0050	5	15	20
0075	7.5	22	30
0100	10	28	35
0150	15	42	60
0200	20	54	80
0250	25	68	90
0300	30	80	100
0400	40	104	150
0500	50	130	175
0600	60	154	200

Table 45: Line power supply 3x380–480 V AC

Frequency converter	HP rating	Continuous input current (3x441–480 V AC)	NEC fuse size
0015	1.5	2.7	6
0020	2	3.1	6
0030	3	4.3	6
0050	5	7.4	10
0075	7.5	9.9	15
0100	10	13	20
0150	15	19	25
0200	20	25	35
0250	25	31	40
0300	30	36	45
0400	40	47	60
0500	50	59	80
0600	60	73	100
0750	75	95	125
1000	100	118	150
1250	125	145	200

Table 46: Line power supply 3x525–600 V AC

Frequency converter	HP rating	Continuous input current (3x525–600 V AC)	NEC fuse size
0015	1.5	2.4	6
0020	2	2.7	6
0030	3	4.1	6
0050	5	5.8	10
0075	7.5	8.6	10
0100	10	10.4	15
0150	15	17.2	25
0200	20	20.9	30
0250	25	25.4	35
0300	30	32.7	40
0400	40	39	50
0500	50	49	80
0600	60	59	80
0750	75	78.9	100
1000	100	95.3	125
1250	125	124.3	175

UL Compliance

Table 47: 1 x 200–240 V

Recommended maximum fuse													
Frequency Converter	Max. prefuse size [A]	Bussmann							SIBA	Littel-fuse	Ferraz-Shawmut		
		JFHR2	RK1	J	T	CC	CC	CC	RK1	RK1	CC	RK1	J
0015	15	FWX-15	KTN-15	JKS-15	JJN-15	FNQ-R-15	KTK-R-15	LP-CC-15	501790 6-016	KLN-R15	ATM-R15	A2K-15 R	HSJ15
0020	20	FWX-20	KTN-R20	JKS-20	JJN-20	FNQ-R-20	KTK-R-20	LP-CC-20	501790 6-020	KLN-R20	ATM-R20	A2K-20 R	HSJ20
0030	30*	FWX-30	KTN-R30	JKS-30	JJN-30	FNQ-R-30	KTK-R-30	LP-CC-30	501240 6-032	KLN-R30	ATM-R30	A2K-30 R	HSJ30
0050	50	FWX-50	KTN-R50	JKS-50	JJN-50				501400 6-050	KLN-R50	–	A2K-50 R	HSJ50
0075	60**	FWX-60	KTN-R60	JKS-60	JJN-60				501400 6-050	KLN-R60	–	A2K-60 R	HSJ60
0100	80	FWX-80	KTN-R80	JKS-80	JJN-80				501400 6-080	KLN-R80	–	A2K-80 R	HSJ80
0200	150	FWX-150	KTN-R150	JKS-150	JJN-150				202822 0-150	KLN-R150		A2K-150 OR	HSJ150
0300	200	FWX-200	KTN-R200	JKS-200	JJN-200				202822 0-200	KLN-R200		A2K-200 OR	HSJ200

* Siba allowed up to 32 A; ** Siba allowed up to 63A

Table 48: 1 x 380-480 V, Enclosure Types B and C

Recommended maximum fuse													
Frequency Converter	Max. pre-fuse size [A]	Bussmann							SIBA	Littel fuse	Ferraz-Shawmut		
		JFHR2	RK1	J	T	CC	CC	CC	RK1	RK1	CC	RK1	J
0100	60	FWH-60	KTS-R60	JKS-60	JJS-60				501500 6-063	KLS-R60	–	A6K-60R	HSJ60
0150	80	FWH-80	KTS-R80	JKS-R80	JJS-80				202822 0-100	KLS-R80	–	A6K-80R	HSJ80
0250	150	FWH-150	KTS-R150	JKS-150	JJS-150				202822 0-160	KLS-R150	–	A6K-150R	HSJ150
0500	200	FWH-200	KTS-R200	JKS-200	JJS-200				202822 0-200	KLS-200		A6K-200R	HSJ200

- KTS-fuses from Bussmann may substitute KTN for 240 V frequency converters.
- FWH-fuses from Bussmann may substitute FWX for 240 V frequency converters.
- JJS-fuses from Bussmann may substitute JJN for 240 V frequency converters.
- KLSR fuses from Littel fuse may substitute KLNLR fuses for 240 V frequency converters.
- A6KR fuses from Ferraz-Shawmut may substitute A2KR for 240 V frequency converters.

Table 49: 3 x 200-240 V, Enclosure Types A, B, and C

Recommended maximum fuse						
Frequency converter	Bussmann Type RK1 ¹ .	Bussmann Type J	Bussmann Type T	Bussmann Type CC	Bussmann Type CC	Bussmann Type CC
0015	KTN-R-10	JKS-10	JJN-10	FNQ-R-10	KTK-R-10	LP-CC-10
0020	KTN-R-15	JKS-15	JJN-15	FNQ-R-15	KTK-R-15	LP-CC-15
0030	KTN-R-20	JKS-20	JJN-20	FNQ-R-20	KTK-R-20	LP-CC-20
0050	KTN-R-30	JKS-30	JJN-30	FNQ-R-30	KTK-R-30	LP-CC-30
0075	KTN-R-50	JKS-50	JJN-50	–	–	–
0100						
0150	KTN-R-60	JKS-60	JJN-60	–	–	–
0200	KTN-R-80	JKS-80	JJN-80	–	–	–
0250	KTN-R-125	JKS-125	JJN-125	–	–	–
0300						
0400	KTN-R-150	JKS-150	JJN-150	–	–	–
0500	KTN-R-200	JKS-200	JJN-200	–	–	–
0600	KTN-R-250	JKS-250	JJN-250	–	–	–

Table 50: 3 x 200-240 V, Enclosure Types A, B, and C

Recommended maximum fuse								
Frequency converter	SIBA Type RK1	Littelfuse Type RK1	Ferraz-Shawmut Type CC	Ferraz-Shawmut Type RK1 ³ .	Bussmann Type JFHR2 ² .	Littelfuse JFHR2	Ferraz-Shawmut JFHR2 ⁴ .	Ferraz-Shawmut J
0015	5017906-010	KLN-R-10	ATM-R-10	A2K-10-R	FWX-10	–	–	HSJ-10
0020	5017906-016	KLN-R-15	ATM-R-15	A2K-15-R	FWX-15	–	–	HSJ-15
0030	5017906-020	KLN-R-20	ATM-R-20	A2K-20-R	FWX-20	–	–	HSJ-20
0050	5012406-032	KLN-R-30	ATM-R-30	A2K-30-R	FWX-30	–	–	HSJ-30
0075	5014006-050	KLN-R-50	–	A2K-50-R	FWX-50	–	–	HSJ-50
0100								

Recommended maximum fuse								
Frequency converter	SIBA Type RK1	Littelfuse Type RK1	Ferraz-Shawmut Type CC	Ferraz-Shawmut Type RK1 ³ .	Bussmann Type JFHR2 ² .	Littelfuse JFHR2	Ferraz-Shawmut JFHR2 ⁴ .	Ferraz-Shawmut J
0150	5014006-063	KLN-R-60	–	A2K-60-R	FWX-60	–	–	HSJ-60
0200	5014006-080	KLN-R-80	–	A2K-80-R	FWX-80	–	–	HSJ-80
0250 0300	2028220-125	KLN-R-125	–	A2K-125-R	FWX-125	–	–	HSJ-125
0400	2028220-150	KLN-R-150	–	A2K-150-R	FWX-150	L25S-150	A25X-150	HSJ-150
0500	2028220-200	KLN-R-200	–	A2K-200-R	FWX-200	L25S-200	A25X-200	HSJ-200
0600	2028220-250	KLN-R-250	–	A2K-250-R	FWX-250	L25S-250	A25X-250	HSJ-250

1. KTS fuses from Bussmann may substitute KTN for 240 V adjustable frequency drives.
2. FWH fuses from Bussmann may substitute FWX for 240 V adjustable frequency drives.
3. A6KR fuses from FERRAZ SHAWMUT may substitute A2KR for 240 V adjustable frequency drives.
4. A50X fuses from FERRAZ SHAWMUT may substitute A25X for 240 V adjustable frequency drives.

Table 51: 3 X 380–480 V, Enclosure Types A, B, and C

Recommended maximum fuse						
Frequency converter	Bussmann Type RK1	Bussmann Type J	Bussmann Type T	Bussmann Type CC	Bussmann Type CC	Bussmann Type CC
0015	KTS-R-6	JKS-6	JJS-6	FNQ-R-6	KTK-R-6	LP-CC-6
0020 0030	KTS-R-10	JKS-10	JJS-10	FNQ-R-10	KTK-R-10	LP-CC-10
0050	KTS-R-20	JKS-20	JJS-20	FNQ-R-20	KTK-R-20	LP-CC-20
0075	KTS-R-25	JKS-25	JJS-25	FNQ-R-25	KTK-R-25	LP-CC-25
0100	KTS-R-30	JKS-30	JJS-30	FNQ-R-30	KTK-R-30	LP-CC-30
0150 0200	KTS-R-40	JKS-40	JJS-40	–	–	–
0250	KTS-R-50	JKS-50	JJS-50	–	–	–
0300	KTS-R-60	JKS-60	JJS-60	–	–	–
0400	KTS-R-80	JKS-80	JJS-80	–	–	–
0500	KTS-R-100	JKS-100	JJS-100	–	–	–
0600	KTS-R-125	JKS-125	JJS-125	–	–	–
0750	KTS-R-150	JKS-150	JJS-150	–	–	–
1000	KTS-R-200	JKS-200	JJS-200	–	–	–
1250	KTS-R-250	JKS-250	JJS-250	–	–	–

Table 52: 3 x 380–480 V, Enclosure Types A, B, and C

Recommended maximum fuse								
Frequency converter	SIBA Type RK1	Littelfuse Type RK1	Ferraz-Shawmut Type CC	Ferraz-Shawmut Type RK1	Bussmann JFHR2	Ferraz-Shawmut J	Ferraz-Shawmut JFHR2 ¹ .	Littelfuse JFHR2
0015	5017906-006	KLS-R-6	ATM-R-6	A6K-10-6	FWH-6	HSJ-6	–	–
0020 0030	5017906-010	KLS-R-10	ATM-R-10	A6K-10-R	FWH-10	HSJ-10	–	–

Recommended maximum fuse								
Frequency converter	SIBA Type RK1	Littelfuse Type RK1	Ferraz-Shawmut Type CC	Ferraz-Shawmut Type RK1	Bussmann JFHR2	Ferraz-Shawmut J	Ferraz-Shawmut JFHR2 ¹	Littelfuse JFHR2
0050	5017906-020	KLS-R-10	ATM-R-20	A6K-20-R	FWH-20	HSJ-20	–	–
0075	5017906-025	KLS-R-25	ATM-R-25	A6K-25-R	FWH-25	HSJ-25	–	–
0100	5012406-032	KLS-R-30	ATM-R-30	A6K-30-R	FWH-30	HSJ-30	–	–
0150 0200	5014006-040	KLS-R-40	–	A6K-40-R	FWH-40	HSJ-40	–	–
0250	5014006-050	KLS-R-50	–	A6K-50-R	FWH-50	HSJ-50	–	–
0300	5014006-063	KLS-R-60	–	A6K-60-R	FWH-60	HSJ-60	–	–
0400	2028220-100	KLS-R-80	–	A6K-80-R	FWH-80	HSJ-80	–	–
0500	2028220-125	KLS-R-100	–	A6K-100-R	FWH-100	HSJ-100	–	–
0600	2028220-125	KLS-R-125	–	A6K-125-R	FWH-125	HSJ-125	–	–
0750	2028220-160	KLS-R-150	–	A6K-150-R	FWH-150	HSJ-150	–	–
1000	2028220-200	KLS-R-200	–	A6K-200-R	FWH-200	HSJ-200	A50-P-225	L50-S-225
1250	2028220-250	KLS-R-250	–	A6K-250-R	FWH-250	HSJ-250	A50-P-250	L50-S-250

1. Ferraz-Shawmut A50QS may substitute A50P fuses.

Table 53: 3 X 525-600 V, Enclosure Types A, B, and C

Recommended maximum fuse										
Frequency converter	Bussmann Type RK1	Bussmann Type J	Bussmann Type T	Bussmann Type CC	Bussmann Type CC	Bussmann Type CC	SIBA Type RK1	Littelfuse Type RK1	Ferraz-Shawmut Type RK1	Ferraz-Shawmut J
0015	KTS-R-5	JKS-5	JJS-6	FNQ-R-5	KTK-R-5	LP-CC-5	5017906-005	KLS-R-005	A6K-5-R	HSJ-6
0020 0030	KTS-R-10	JKS-10	JJS-10	FNQ-R-10	KTK-R-10	LP-CC-10	5017906-010	KLS-R-010	A6K-10-R	HSJ-10
0050	KTS-R-20	JKS-20	JJS-20	FNQ-R-20	KTK-R-20	LP-CC-20	5017906-020	KLS-R-020	A6K-20-R	HSJ-20
0075	KTS-R-25	JKS-25	JJS-25	FNQ-R-25	KTK-R-25	LP-CC-25	5017906-025	KLS-R-025	A6K-25-R	HSJ-25
0100	KTS-R-30	JKS-30	JJS-30	FNQ-R-30	KTK-R-30	LP-CC-30	5017906-030	KLS-R-030	A6K-30-R	HSJ-30
0150 0200	KTS-R-35	JKS-35	JJS-35	–	–	–	5014006-040	KLS-R-035	A6K-35-R	HSJ-35
0250	KTS-R-45	JKS-45	JJS-45	–	–	–	5014006-050	KLS-R-045	A6K-45-R	HSJ-45
0300	KTS-R-50	JKS-50	JJS-50	–	–	–	5014006-050	KLS-R-050	A6K-50-R	HSJ-50
0400	KTS-R-60	JKS-50	JJS-60	–	–	–	5014006-063	KLS-R-060	A6K-60-R	HSJ-60
0500	KTS-R-80	JKS-80	JJS-80	–	–	–	5014006-080	KLS-R-075	A6K-80-R	HSJ-80
0600	KTS-R-100	JKS-100	JJS-100	–	–	–	5014006-100	KLS-R-100	A6K-100-R	HSJ-100
0750	KTS-R-125	JKS-125	JJS-125	–	–	–	2028220-125	KLS-125	A6K-125-R	HSJ-125

Recommended maximum fuse										
Frequency converter	Bussmann Type RK1	Bussmann Type J	Bussmann Type T	Bussmann Type CC	Bussmann Type CC	Bussmann Type CC	SIBA Type RK1	Littelfuse Type RK1	Ferraz-Shawmut Type RK1	Ferraz-Shawmut J
1000	KTS-R-150	JKS-150	JJS-150	–	–	–	2028220-150	KLS-150	A6K-150-R	HSJ-150
1250	KTS-R-175	JKS-175	JJS-175	–	–	–	2028220-200	KLS-175	A6K-175-R	HSJ-175

Connection tightening torques

Table 54: Tightening of terminals

Enclosure	Power (HP)				Torque (Nm)					
	208-230 V	380-460 V	575 V	525-600 V	Mains	Motor	DC connection	Brake	Earth	Relay
A2	1.5-3	1.5-5			1.8	1.8	1.8	1.8	3	0.6
A4	1.5-3	1.5-5			1.8	1.8	1.8	1.8	3	0.6
A5	1.5	1.5-10	1.5-10		1.8	1.8	1.8	1.8	3	0.6
B1	7.5-15	15-25	15-25		1.8	1.8	1.5	1.5	3	0.6
B2	20	30-40	30-40	15-40	4.5	4.5	3.7	3.7	3	0.6
B3	7.5-15	15-25	15-25		1.8	1.8	1.8	1.8	3	0.6
B4	20-25	30-50	30-50	15-50	4.5	4.5	4.5	4.5	3	0.6
C1	25-40	50-75	50-75		10	10	10	10	3	0.6
C2	50-60	100-125	100-125	50-125	14/24 ¹⁾	14/24 ¹⁾	14	14	3	0.6
C3		60-75	60-75	60-75	10	10	10	10	3	0.6
C4	50-75	100-125	100-125		14/24 ¹⁾	14/24 ¹⁾	14	14	3	0.6

1) For different cable dimensions x/y, where $x \leq 95 \text{ mm}^2$ and $y \geq 95 \text{ mm}^2$.

10.4 Wire sizing charts

VFD input wire sizing

Line Power Supply	Maximum Allowable Conductor Length (45°C Ambient, 5% drop)																							
	Conductor Size for 75°C Rated Wire (Lengths in Bold Require 90°C Rated Wire)																							
	Controller Ratings		14	12	10	8	6	4	3	2	1	1/0	2/0	3/0	4/0	250	300	350	400	500	600	750	1000	
Frequency Converter	HP Rating	Input Current																						
0015	1.5	12.5	166	264	421	667	1037	1654	2079	2626	3308													
0020	2	15	138	220	351	556	864	1378	1733	2188	2756	3479												
0030	3	20.5		161	257	407	633	1008	1268	1601	2017	2546	3212											
0050	5	32			260	405	646	812	1026	1292	1631	2058	2597	3272	3863	3226	3771							
0075	7.5	46				282	449	565	713	899	1135	1431	1807	2277	2688	2940	3362							
0100	10	59					350	440	556	701	885	1116	1409	1775	2095	2515	2940	3362						
0200	20	111									470	593	749	943	1114	1337	1563	1787	2223	2680	3354	2165	2870	
0300	30	172														863	1009	1153	1435	1730	2165	2870		
0100	10	33				253	393	626	788	995	1253	1581	1995	2519	3173	3746								
0150	15	48					270	431	541	694	861	1087	1372	1732	2182	2576	3092	3614						
0250	25	78								421	530	669	844	1066	1343	1585	1903	2224	2543	3164	3814			
0500	50	151												550	694	819	983	1149	1314	1634	1970	2466	3269	
0015	1.5	5.9	352	559	892	1412	2198	3504																
0020	2	6.8	305	485	774	1226	1907	3040	3822															
0030	3	9.5	218	347	554	877	1366	2176	2736	3455														
0050	5	15	138	220	351	556	864	1378	1733	2188	2756	3479												
0075	7.5	22			239	379	589	940	1181	1492	1879	2372	2993	3778	4493	2944	3534							
0100	10	28				298	463	738	928	1172	1477	1864	2352	2969	3740	2944	3534							
0150	15	42					309	482	619	781	984	1243	1568	1979	2493	2944	3534							
0200	20	54						383	481	608	766	966	1219	1539	1939	2289	2748	3213	3673					
0250	25	68							382	483	608	767	968	1222	1540	1818	2183	2551	2917	3629				
0300	30	80								410	517	652	823	1039	1309	1545	1855	2169	2479	3085	3719			
0400	40	104									398	502	633	799	1007	1189	1427	1668	1907	2373	2861	3580		
0500	50	130										506	639	806	951	1142	1335	1526	1898	2289	2864	3797		
0600	60	154											540	680	803	964	1127	1288	1602	1932	2418	3205		
0015	1.5	2.7	1536	2444	3898																			
0020	2	3.7	1121	1783	2844																			
0030	3	5	830	1320	2105	3333																		
0050	5	9	461	733	1169	1852	2882																	
0075	7.5	11.7	355	564	899	1425	2217	3534																
0100	10	14.4	288	458	731	1157	1801	2871	3609															
0150	15	22			478	758	1179	1879	2363	2984	3759													
0200	20	29				575	894	1426	1792	2263	2851	3599												
0250	25	34				490	763	1216	1529	1931	2432	3070	3873											
0300	30	40					648	1034	1299	1641	2067	2609	3292											
0400	40	55						752	945	1193	1503	1898	2394	3023	3808									
0500	50	66						626	788	995	1253	1581	1995	2519	3173	3746								
0600	60	82							800	1008	1273	1606	2027	2554	3015	3620								
0750	75	96								861	1067	1372	1732	2182	2576	3092	3614							
1000	100	133									990	1250	1575	1859	2232	2609	3092	3614						
1250	125	161										1250	1575	1859	2232	2609	3092	3614						
													1301	1536	1844	2155	2464	2983	3711	3066	3696			

Line Power Supply		Controller Ratings		Maximum Allowable Conductor Length (45°C Ambient, 5% dIrop)																					
		Frequency Converter	HP Rating	Input Current	Conductor Size for 75 °C Rated Wire (Lengths in Bold Require 90 °C Rated Wire)																				
					14	12	10	8	6	4	3	2	1	1/0	2/0	3/0	4/0	250	300	350	400	500	600	750	1000
3x525-600V	0015	1.5	2.4	2160	3436																				
	0020	2	2.7	1920	3055																				
	0030	3	4.1	1265	2012	3209																			
	0050	5	5.8	894	1422	2268	3592																		
	0075	7.5	8.6	603	959	1530	2423	3770																	
	0100	10	10.4	499	793	1265	2003	3117																	
	0150	15	17.2	301	479	765	1211	1885	3005	3777															
	0200	20	20.9			629	997	1551	2473	3109	3926														
	0250	25	25.4			518	820	1276	2035	2558	3230														
	0300	30	32.7				637	991	1580	1987	2509	3161	3990												
	0400	40	39					831	1325	1666	2104	2650	3345	3359											
	0500	50	49					662	1055	1326	1674	2109	2663	3359	3359										
	0600	60	59						876	1101	1391	1752	2211	2790	3522										
	0750	75	78.9								1040	1310	1654	2086	2634	3318	3917								
	1000	100	95.3									1085	1369	1727	2180	2747	3243	3893							
1250	125	124.3													1324	1672	2106	2487	2985	3489	3989				

VFD output wire sizing

Con- troller Input	Maximum Allowable Conductor Length (45°C Ambient, 5% drop)																							
	Controller Ratings		Conductor Size for 75°C Rated Wire (Lengths in Bold Require 90°C Rated Wire)																					
	Frequency Converter	HP Rating	Input Current	14	12	10	8	6	4	3	2	1	1/0	2/0	3/0	4/0	250	300	350	400	500	600	750	1000
1x200-240V	0015	1.5	6.6	166	264	421	667	1037	1654	2079	2626	3308												3451
	0020	2	7.5	277	440	702	1111	1729	2756	3465														2903
	0030	3	10.6	196	311	496	786	1223	1950	2452	3096	3900												
	0050	5	16.7	124	198	315	499	776	1238	1556	1965	2476	3125	3943										
	0075	7.5	24.2			217	344	536	854	1074	1356	1708	2157	2721	3435									
	0100	10	30.8				271	421	671	844	1066	1342	1694	2138	2699	3400								
	0200	20	59.4						348	438	553	696	879	1108	1399	1763	2081	2499	2921	3339				
	0300	30	88								373	470	593	748	945	1190	1405	1687	1971	2254	2804	3381		
	0100	10	16	130	206	329	521	810	1292	1624	2051	2584	3262											
	0150	15	24			219	347	540	861	1083	1367	1723	2175	2743	3463									
0250	25	37.5				222	346	551	693	875	1103	1392	1756	2217	2793	3297	3958							
0500	50	73								356	450	566	715	902	1139	1435	1694	2033	2377	2717	3381			
0015	1.5	6.6	314	500	797	1263	1965	3132	3938															
0020	2	7.5	277	440	702	1111	1729	2756	3465															
0030	3	10.6	196	311	496	786	1223	1950	2452	3096	3900													
0050	5	16.7	124	198	315	499	776	1238	1556	1965	2476	3125	3943											
0075	7.5	24.2			217	344	536	854	1074	1356	1708	2157	2721	3435										
0100	10	30.8				271	421	671	844	1066	1342	1694	2138	2699	3400									
0150	15	46.2					281	447	563	710	895	1130	1425	1799	2267	2676	3212	3755						
0200	20	59.4								553	696	879	1108	1399	1763	2081	2499	2921	3339					
0250	25	74.8								347	439	553	698	880	1111	1400	1653	1984	2319	2652	3299	3978		
0300	30	88									373	470	593	748	945	1190	1405	1687	1971	2254	2804	3381		
0400	40	115											454	573	723	911	1075	1291	1509	1725	2146	2587	3238	
0500	50	143													581	732	865	1038	1213	1387	1726	2081	2604	
0600	60	170															616	727	873	1021	1167	1452	1750	2190
0015	1.5	3	1383	2199	3508																			
0020	2	4.1	1012	1609	2567																			
0030	3	5.6	741	1178	1879	2976																		
0050	5	10	415	660	1052	1667	2593																	
0075	7.5	13	319	508	810	1282	1995	3180	3998															
0100	10	16	259	412	658	1042	1621	2584	3248															
0150	15	24			694	1081	1723	2166	2735	3445														
0200	20	32			521	810	1292	1624	2051	2584	3262													
0250	25	37.5				444	692	1103	1366	1750	2205	2783	3512											
0300	30	44					589	940	1181	1492	1879	2372	2993	3778										
0400	40	61								1076	1356	1711	2159	2725	3433									
0500	50	73								899	1133	1430	1804	2277	2869	3387								
0600	60	90								712	919	1160	1463	1847	2327	2747	3298	3855						
0750	75	106									729	985	1242	1568	1976	2333	2800	3273	3742					
1000	100	147											1131	1425	1882	2019	2360	2699	3058	3358				
1250	125	177													1183	1397	1677	1960	2241	2788	3362			

10.5 Parameter list

0-0*	Operation / Display	1-1*	Load and Motor	1-9*	Motor Temperature	4-12	Sleep Frequency/Low Limit [Hz]	5-59	Pulse Filter Time Constant #33
0-0*	Basic Settings	1-10	Motor Construction	1-90	Motor Thermal Protection	4-13	Motor Speed High Limit [RPM]	5-6*	Pulse Output
0-01	Language	1-11	VVC+ PM	1-91	Motor External Fan	4-14	Motor Speed Low Limit [RPM]	5-60	Terminal 27 Pulse Output Variable
0-02	Motor Speed Unit	1-14	Damping Gain	1-93	Thermistor Source	4-16	Torque Speed High Limit [Hz]	5-62	Terminal 27 Pulse Output Variable
0-03	Regional Settings	1-15	Low Speed Filter Time Const.	1-94	ATEX ETR cur.lim. speed reduction	4-17	Torque Limit Motor Mode	5-63	Terminal 29 Pulse Output Variable
0-04	Operating State at Power-up	1-16	High Speed Filter Time Const.	1-98	ATEX ETR interpul. points freq.	4-18	Torque Limit Generator Mode	5-65	Pulse Output Max Freq. #29
0-05	Local Mode Unit	1-17	Voltage filter time const.	1-99	ATEX ETR interpul. points current	4-19	Max Output Frequency	5-66	Terminal X30/6 Pulse Output Variable
0-1*	Set-up Operations	1-20	Motor Data	2-0*	Brakes	4-5*	Adj. Warnings	5-68	Terminal X30/6 Pulse Output Variable
0-10	Active Set-up	1-21	Motor Power [kW]	2-00	DC-Brake	4-50	Warning Current Low	5-8*	IO Options
0-11	Programming Set-up	1-22	Motor Current	2-01	DC Hold/Preheat Current	4-51	Warning Current High	5-9*	AHF Cap Reconnect Delay
0-12	This Setup Linked to	1-23	Motor Voltage	2-02	DC Brake Current	4-52	Warning Speed Low	5-9*	Bus Controlled
0-13	Readout: Linked Set-ups / Channel	1-24	Motor Frequency	2-03	DC Braking Time	4-53	Warning Speed High	5-90	Digital & Relay Bus Control
0-14	Readout: actual setup	1-25	Motor Nominal Speed	2-04	DC Brake Cut In Speed [RPM]	4-54	Warning Reference Low	5-93	Pulse Out #27 Bus Control
0-15	Readout: actual setup	1-26	Motor Cont. Rated Torque	2-05	DC Brake Cut In Speed [Hz]	4-55	Warning Reference High	5-94	Pulse Out #27 Timeout/Preset
0-20	Display Line 1.1 Small	1-27	Motor Rotation Check	2-06	Parking Time	4-56	Warning Feedback Low	5-95	Pulse Out #29 Bus Control
0-21	Display Line 1.2 Small	1-28	Automatic Motor Adaptation (AMA)	2-07	Brake Energy Funct.	4-57	Warning Feedback High	5-96	Pulse Out #29 Timeout/Preset
0-22	Display Line 1.3 Small	1-29	Adv. Motor Data	2-1*	Brake Function	4-58	Missing Motor Phase Function	5-97	Pulse Out #X30/6 Bus Control
0-23	Display Line 2 Large	1-30	Stator Resistance (Rs)	2-10	Brake Resistor (ohm)	4-59	Motor Check At Start	5-98	Pulse Out #X30/6 Timeout/Preset
0-24	Display Line 3 Large	1-31	Rotor Resistance (Rr)	2-11	Brake Resistor (ohm)	4-60	Speed Bypass	6-0*	Analog In/Out
0-25	My Personal Menu	1-32	Main Reactance (Xh)	2-12	Brake Power Limit (kW)	4-61	Bypass Speed From [RPM]	6-0*	Analog I/O Mode
0-26	Display Mode	1-33	Iron Loss Resistance (Rfe)	2-13	Brake Power Monitoring	4-62	Bypass Speed To [Hz]	6-00	Sensor Fault Timeout Time
0-27	LCP Step Size	1-34	d-axis Inductance (Ld)	2-14	Brake Check	4-63	Semi-Auto Bypass Set-up	6-00	(North America)
0-28	LCP Ramp	1-35	Motor Poles	2-15	AC brake Max. Current	4-64	Digital In/Out	6-01	Sensor Fault Timeout Function
0-29	LCP Custom Readout	1-36	Position Detection Gain	2-16	Over-voltage Control	4-64	Digital I/O Mode	6-01	(North America)
0-30	Custom Readout Unit	1-37	Load Indep. Setting	2-17	Reference / Ramps	5-0*	Digital I/O Mode	6-01	Live Zero Timeout Function (International)
0-31	Custom Readout Min Value	1-38	Motor Magnetsation at Zero Speed	3-02	Reference 1 Source	5-00	Digital I/O Mode	6-02	Fire Mode Sensor Fault Timeout Function
0-32	Custom Readout Max Value	1-39	Min Speed Normal Magnetising [RPM]	3-03	Reference 2 Source	5-01	Digital I/O Mode	6-02	(North America)
0-37	Display Text 1	1-40	Min Speed Normal Magnetising [Hz]	3-04	Reference 3 Source	5-01	Digital I/O Mode	6-02	Fire Mode Live Zero Timeout Function
0-38	Display Text 2	1-41	Flystart Test Pulses Frequency	3-05	Jog Speed [RPM]	5-01	Digital I/O Mode	6-02	(International)
0-39	Display Text 3	1-42	Load Deppen. Setting	3-06	Ramp 1	5-02	Digital Inputs	6-1*	Analog Input 53
0-4*	LCP keypad	1-43	Resonance Dampening	3-07	Ramp 2	5-02	Terminal 18 Digital Input	6-10	Terminal 53 Low Voltage
0-40	[Hnd on] Key on LCP	1-44	Resonance Dampening Time Constant	3-08	Quick Stop Ramp Time	5-03	Terminal 19 Digital Input	6-11	Terminal 53 High Voltage
0-41	[Off] Key on LCP	1-45	Min. Current at Low Speed	3-09	Starting Ramp Up Time	5-03	Terminal 20 Digital Input	6-12	Terminal 53 Low Current
0-42	[Auto on] Key on LCP	1-46	Start Adjustments	3-10	Step Size	5-04	Terminal 21 Digital Input	6-12	Terminal 53 Low Current
0-43	[Reset] Key on LCP	1-47	Compressor Start Max Speed [RPM]	3-11	Ramp Time	5-04	Terminal 22 Digital Input	6-13	Terminal 53 High Current
0-44	[Off/Reset] Key on LCP	1-48	Compressor Start Max Speed [Hz]	3-12	Power Restore	5-05	Terminal 23 Digital Input	6-14	Terminal 53 Low Ref./Feedb. Value
0-45	[Drive Bypass] Key on LCP	1-49	Compressor Start Max Time to Trip	3-13	Maximum Limit	5-05	Terminal 24 Digital Input	6-15	Terminal 53 High Ref./Feedb. Value
0-5*	Copy/Save	1-50	Function at Stop [RPM]	3-14	Minimum Limit	5-06	Terminal 25 Digital Input	6-16	Terminal 53 Filter Time Constant
0-50	LCP Copy	1-51	Min Speed for Function at Stop [Hz]	3-15	Maximum Limit	5-06	Terminal 26 Digital Input	6-17	Terminal 53 Sensor Fault (North America)
0-51	Set-up Copy	1-52	Trip Speed Low [RPM]	3-16	Minimum Limit	5-07	Terminal 27 Digital Output	6-17	Terminal 53 Live Zero (International)
0-5*	Password	1-53	Trip Speed High [Hz]	3-17	Motor Limits	5-07	Terminal 28 Digital Output	6-2*	Analog Input 54
0-6*	Password	1-54	Additional Non-Working Days	3-18	Motor Speed Direction	5-08	Terminal 29 Digital Output	6-20	Terminal 54 Low Voltage
0-60	Main Menu Password	1-55	Motor Speed Low Limit [RPM]	3-19	Motor Speed Low Limit [RPM]	5-08	Terminal 30 Digital Output	6-21	Terminal 54 High Voltage
0-61	Access to Main Menu w/o Password	1-56	Motor Speed Low Limit [RPM]	3-20	Motor Speed Low Limit [RPM]	5-08	Terminal 31 Digital Output	6-22	Terminal 54 Low Current
0-65	Personal Menu Password	1-57	Motor Speed Low Limit [RPM]	3-21	Motor Speed Low Limit [RPM]	5-08	Terminal 32 Digital Output	6-23	Terminal 54 High Current
0-66	Access to Personal Menu w/o Password	1-58	Motor Speed Low Limit [RPM]	3-22	Motor Speed Low Limit [RPM]	5-08	Terminal 33 Digital Input	6-24	Terminal 54 Low Ref./Feedb. Value
0-67	Bus Access Password	1-59	Motor Speed Low Limit [RPM]	3-23	Motor Speed Low Limit [RPM]	5-08	Terminal 34 Digital Input	6-25	Terminal 54 High Ref./Feedb. Value
0-70	Date and Time	1-60	Motor Speed Low Limit [RPM]	3-24	Motor Speed Low Limit [RPM]	5-08	Terminal 35 Digital Input	6-26	Terminal 54 Filter Time Constant
0-71	Date Format	1-61	Motor Speed Low Limit [RPM]	3-25	Motor Speed Low Limit [RPM]	5-08	Terminal 36 Digital Input	6-27	Terminal 54 Sensor Fault (North America)
0-72	Time Format	1-62	Motor Speed Low Limit [RPM]	3-26	Motor Speed Low Limit [RPM]	5-08	Terminal 37 Digital Input	6-27	Terminal 54 Live Zero (International)
0-74	DST/Summerime	1-63	Motor Speed Low Limit [RPM]	3-27	Motor Speed Low Limit [RPM]	5-08	Terminal 38 Digital Input	6-3*	Analog Input X30/11
0-76	DST/Summerime Start	1-64	Motor Speed Low Limit [RPM]	3-28	Motor Speed Low Limit [RPM]	5-08	Terminal 39 Digital Input	6-30	Terminal X30/11 Low Voltage
0-77	DST/Summerime End	1-65	Motor Speed Low Limit [RPM]	3-29	Motor Speed Low Limit [RPM]	5-08	Terminal 40 Digital Input	6-31	Terminal X30/11 High Voltage
0-79	Clock Fault	1-66	Motor Speed Low Limit [RPM]	3-30	Motor Speed Low Limit [RPM]	5-08	Terminal 41 Digital Input	6-34	Term. X30/11 Low Ref./Feedb. Value
0-81	Working Days	1-67	Motor Speed Low Limit [RPM]	3-31	Motor Speed Low Limit [RPM]	5-08	Terminal 42 Digital Input	6-35	Term. X30/11 High Ref./Feedb. Value
0-82	Additional Working Days	1-68	Motor Speed Low Limit [RPM]	3-32	Motor Speed Low Limit [RPM]	5-08	Terminal 43 Digital Input	6-36	Term. X30/11 Filter Time Constant
0-83	Additional Non-Working Days	1-69	Motor Speed Low Limit [RPM]	3-33	Motor Speed Low Limit [RPM]	5-08	Terminal 44 Digital Input	6-37	Term. X30/11 Sensor Fault
0-89	Date and Time Readout	1-70	Motor Speed Low Limit [RPM]	3-34	Motor Speed Low Limit [RPM]	5-08	Terminal 45 Digital Input	6-4*	Analog Input X30/12
		1-71	Motor Speed Low Limit [RPM]	3-35	Motor Speed Low Limit [RPM]	5-08	Terminal 46 Digital Input	6-40	Terminal X30/12 Low Voltage
		1-72	Motor Speed Low Limit [RPM]	3-36	Motor Speed Low Limit [RPM]	5-08	Terminal 47 Digital Input		
		1-73	Motor Speed Low Limit [RPM]	3-37	Motor Speed Low Limit [RPM]	5-08	Terminal 48 Digital Input		
		1-74	Motor Speed Low Limit [RPM]	3-38	Motor Speed Low Limit [RPM]	5-08	Terminal 49 Digital Input		
		1-75	Motor Speed Low Limit [RPM]	3-39	Motor Speed Low Limit [RPM]	5-08	Terminal 50 Digital Input		
		1-76	Motor Speed Low Limit [RPM]	3-40	Motor Speed Low Limit [RPM]	5-08	Terminal 51 Digital Input		
		1-77	Motor Speed Low Limit [RPM]	3-41	Motor Speed Low Limit [RPM]	5-08	Terminal 52 Digital Input		
		1-78	Motor Speed Low Limit [RPM]	3-42	Motor Speed Low Limit [RPM]	5-08	Terminal 53 Digital Input		
		1-79	Motor Speed Low Limit [RPM]	3-43	Motor Speed Low Limit [RPM]	5-08	Terminal 54 Digital Input		
		1-80	Motor Speed Low Limit [RPM]	3-44	Motor Speed Low Limit [RPM]	5-08	Terminal 55 Digital Input		
		1-81	Motor Speed Low Limit [RPM]	3-45	Motor Speed Low Limit [RPM]	5-08	Terminal 56 Digital Input		
		1-82	Motor Speed Low Limit [RPM]	3-46	Motor Speed Low Limit [RPM]	5-08	Terminal 57 Digital Input		
		1-83	Motor Speed Low Limit [RPM]	3-47	Motor Speed Low Limit [RPM]	5-08	Terminal 58 Digital Input		
		1-84	Motor Speed Low Limit [RPM]	3-48	Motor Speed Low Limit [RPM]	5-08	Terminal 59 Digital Input		
		1-85	Motor Speed Low Limit [RPM]	3-49	Motor Speed Low Limit [RPM]	5-08	Terminal 60 Digital Input		
		1-86	Motor Speed Low Limit [RPM]	3-50	Motor Speed Low Limit [RPM]	5-08	Terminal 61 Digital Input		
		1-87	Motor Speed Low Limit [RPM]	3-51	Motor Speed Low Limit [RPM]	5-08	Terminal 62 Digital Input		
		1-88	Motor Speed Low Limit [RPM]	3-52	Motor Speed Low Limit [RPM]	5-08	Terminal 63 Digital Input		
		1-89	Motor Speed Low Limit [RPM]	3-53	Motor Speed Low Limit [RPM]	5-08	Terminal 64 Digital Input		
		1-90	Motor Speed Low Limit [RPM]	3-54	Motor Speed Low Limit [RPM]	5-08	Terminal 65 Digital Input		
		1-91	Motor Speed Low Limit [RPM]	3-55	Motor Speed Low Limit [RPM]	5-08	Terminal 66 Digital Input		
		1-92	Motor Speed Low Limit [RPM]	3-56	Motor Speed Low Limit [RPM]	5-08	Terminal 67 Digital Input		
		1-93	Motor Speed Low Limit [RPM]	3-57	Motor Speed Low Limit [RPM]	5-08	Terminal 68 Digital Input		
		1-94	Motor Speed Low Limit [RPM]	3-58	Motor Speed Low Limit [RPM]	5-08	Terminal 69 Digital Input		
		1-95	Motor Speed Low Limit [RPM]	3-59	Motor Speed Low Limit [RPM]	5-08	Terminal 70 Digital Input		
		1-96	Motor Speed Low Limit [RPM]	3-60	Motor Speed Low Limit [RPM]	5-08	Terminal 71 Digital Input		
		1-97	Motor Speed Low Limit [RPM]	3-61	Motor Speed Low Limit [RPM]	5-08	Terminal 72 Digital Input		
		1-98	Motor Speed Low Limit [RPM]	3-62	Motor Speed Low Limit [RPM]	5-08	Terminal 73 Digital Input		
		1-99	Motor Speed Low Limit [RPM]	3-63	Motor Speed Low Limit [RPM]	5-08	Terminal 74 Digital Input		
		2-00	Motor Speed Low Limit [RPM]	3-64	Motor Speed Low Limit [RPM]	5-08	Terminal 75 Digital Input		
		2-01	Motor Speed Low Limit [RPM]	3-65	Motor Speed Low Limit [RPM]	5-08	Terminal 76 Digital Input		
		2-02	Motor Speed Low Limit [RPM]	3-66	Motor Speed Low Limit [RPM]	5-08	Terminal 77 Digital Input		
		2-03	Motor Speed Low Limit [RPM]	3-67	Motor Speed Low Limit [RPM]	5-08	Terminal 78 Digital Input		
		2-04	Motor Speed Low Limit [RPM]	3-68	Motor Speed Low Limit [RPM]	5-08	Terminal 79 Digital Input		
		2-05	Motor Speed Low Limit [RPM]	3-69	Motor Speed Low Limit [RPM]	5-08	Terminal 80 Digital Input		
		2-06	Motor Speed Low Limit [RPM]	3-70	Motor Speed Low Limit [RPM]	5-08	Terminal 81 Digital Input		
		2-07	Motor Speed Low Limit [RPM]	3-71	Motor Speed Low Limit [RPM]	5-08	Terminal 82 Digital Input		
		2-08	Motor Speed Low Limit [RPM]	3-72	Motor Speed Low Limit [RPM]	5-08	Terminal 83 Digital Input		
		2-09	Motor Speed Low Limit [RPM]	3-73	Motor Speed Low Limit [RPM]	5-08	Terminal 84 Digital Input		
		2-10	Motor Speed Low Limit [RPM]	3-74	Motor Speed Low Limit [RPM]	5-08	Terminal 85 Digital Input		
		2-11	Motor Speed Low Limit [RPM]	3-75	Motor Speed Low Limit [RPM]	5-08	Terminal 86 Digital Input		
		2-12	Motor Speed Low Limit [RPM]	3-76	Motor Speed Low Limit [RPM]	5-08	Terminal 87 Digital Input		
		2-13	Motor Speed Low Limit [RPM]	3-77	Motor Speed Low Limit [RPM]	5-08	Terminal 88 Digital Input		
		2-14	Motor Speed Low Limit [RPM]	3-78	Motor Speed Low Limit [RPM]	5-08	Terminal 89 Digital Input		
		2-15	Motor Speed Low Limit [RPM]	3-79	Motor Speed Low Limit [RPM]	5-08	Terminal 90 Digital Input		
		2-16	Motor Speed Low Limit [RPM]	3-80	Motor Speed Low Limit [RPM]	5-08	Terminal 91 Digital Input		
		2-17	Motor Speed Low Limit [RPM]	3-81	Motor Speed Low Limit [RPM]	5-08	Terminal 92 Digital Input		
		2-18	Motor Speed Low Limit [RPM]	3-82	Motor Speed Low Limit [RPM]	5-08	Terminal 93 Digital Input		
		2-19	Motor Speed Low Limit [RPM]	3-83	Motor Speed Low Limit [RPM]	5-08	Terminal 94 Digital Input		
		2-20	Motor Speed Low Limit [RPM]	3-84	Motor Speed Low Limit [RPM]	5-08	Terminal 95 Digital Input		
		2-21	Motor Speed Low Limit [RPM]	3-85	Motor Speed Low Limit [RPM]	5-08	Terminal 96 Digital Input		
		2-22	Motor Speed Low Limit [RPM]	3-86	Motor Speed Low Limit [RPM]	5-08	Terminal 97 Digital Input		
		2-23	Motor Speed Low Limit [RPM]	3-87	Motor Speed Low Limit [RPM]	5-08	Terminal 98 Digital Input		
		2-24	Motor Speed Low Limit [RPM]	3-88	Motor Speed Low Limit [RPM]	5-08	Terminal 99 Digital Input		
		2-25	Motor Speed Low Limit [RPM]	3-89	Motor Speed Low Limit [RPM]	5-08	Terminal 100 Digital Input		

6-41	Terminal X30/12 High Voltage	8-80	Bus Message Count	12-10	IP Address Assignment	13-11	Comparator Operator	14-61	Function at Inverter Overload
6-44	Term. X30/12 Low Ref./Feedb. Value	8-81	Bus Error Count	12-01	IP Address	13-12	Comparator Value	14-62	Inv. Overload Derate Current
6-45	Term. X30/12 High Ref./Feedb. Value	8-82	Slave Messages Rcvd	12-02	Subnet Mask	13-23*	Timers	14-8*	Options
6-46	Term. X30/12 Filter Time Constant	8-83	Slave Error Count	12-03	Default Gateway	13-20	SL Controller Timer	14-89	Option Deletion
6-47	Term. X30/12 Sensor Fault	8-84	Slave Messages Sent	12-04	DHCP Server	13-4*	Logic Rules	14-9*	Fault Settings
6-5*	Analog Output 42	8-85	Slave Timeout Errors	12-05	Lease Expires	13-40	Logic Rule Boolean 1	14-90	Fault Level
6-50	Terminal 42 Output	8-89	Diagnostics Count	12-06	Name Servers	13-41	Logic Rule Operator 1	15-**	Drive Information
6-51	Terminal 42 Output Min Scale	8-9*	Bus Jog / Feedback	12-07	Domain Name	13-42	Logic Rule Boolean 2	15-0*	Operating Data
6-52	Terminal 42 Output Max Scale	8-90	Bus Jog 1 Speed	12-08	Host Name	13-43	Logic Rule Operator 2	15-00	Operating hours
6-53	Terminal 42 Output Bus Control	8-91	Bus Jog 2 Speed	12-09	Physical Address	13-44	Logic Rule Boolean 3	15-01	Running Hours
6-54	Terminal 42 Output Timeout Preset	8-94	Bus Feedback 1	12-1*	Ethernet Link Parameters	13-5*	States	15-02	kWh Counter
6-55	Analog Output Filter	8-95	Bus Feedback 2	12-10	Link Status	13-51	SL Controller Event	15-03	Power Up's
6-6*	Analog Output X30/8	8-96	Bus Feedback 3	12-11	Link Duration	13-52	SL Controller Action	15-04	Over Temp's
6-60	Terminal X30/8 Output	9-**	Profibus	12-12	Auto Negotiation	13-9*	User Defined Alerts	15-05	Over Volt's
6-61	Terminal X30/8 Min. Scale	9-00	Setpoint	12-13	Link Speed	13-90	Alert Trigger	15-06	Reset kWh Counter
6-62	Terminal X30/8 Max. Scale	9-07	Actual Value	12-14	Link Duplex	13-91	Alert Action	15-07	Reset Running Hours Counter
6-63	Terminal X30/8 Output Bus Control	9-15	PCD Write Configuration	12-2*	Process Data	13-92	Alert Text	15-08	Number of Starts
6-64	Terminal X30/8 Output Timeout Preset	9-16	PCD Read Configuration	12-20	Control Instance	13-9*	User Defined Readouts	15-1*	Data Log Settings
8-*	Comm. and Options	9-18	Node Address	12-21	Process Data Config Write	13-97	Alert Alarm Word	15-10	Logging Source
8-0*	General Settings	9-22	Telegram Selection	12-22	Process Data Config Read	13-98	Alert Warning Word	15-11	Logging Interval
8-01	Control Site	9-23	Parameters for Signals	12-27	Primary Master	13-99	Alert Status Word	15-12	Trigger Event
8-02	Control Source	9-27	Parameter Edit	12-28	Store Data Values	14-**	Special Functions	15-13	Logging Mode
8-03	Control Timeout Time	9-28	Process Control	12-29	Store Always	14-0*	Inverter Switching	15-14	Samples Before Trigger
8-04	Control Timeout Function	9-44	Fault Message Counter	12-30	Warning Parameter	14-00	Switching Pattern	15-2*	Historic Log
8-05	End-of-Timeout Function	9-45	Fault Code	12-31	Net Reference	14-01	Switching Frequency	15-20	Historic Log: Event
8-06	Reset Control Timeout	9-47	Fault Number	12-32	Net Control	14-03	Overmodulation	15-21	Historic Log: Value
8-07	Diagnosis Trigger	9-52	Fault Situation Counter	12-33	Net Control	14-04	PWM Random	15-22	Historic Log: Time
8-08	Readout Filtering	9-53	Profibus Warning Word	12-34	CIP Revision	14-1*	Mains On/Off	15-23	Historic log: Date and Time
8-09	Communication Charset	9-63	Actual Baud Rate	12-35	CIP Product Code	14-10	Mains Failure	15-3*	Alarm Log
8-1*	Control Settings	9-64	Device Identification	12-36	COS Parameter	14-11	Mains Voltage at Mains Fault	15-30	Alarm Log: Error Code
8-10	Control Profile	9-65	Profile Number	12-37	COS Inhibit Timer	14-12	Function at Mains Imbalance	15-31	Alarm Log: Value
8-13	Configurable Status Word STW	9-67	Control Word 1	12-38	COS Filter	14-16	Kn. Backup Gain	15-32	Alarm Log: Time
8-3*	FC Port Settings	9-68	Status Word 1	12-4*	Modbus TCP	14-2*	Reset Functions	15-33	Alarm Log: Date and Time
8-30	Protocol	9-71	Profibus Save Data Values	12-40	Status Parameter	14-20	Reset Mode	15-40	FC Type
8-31	Address	9-72	ProfibusDriveReset	12-41	Slave Message Count	14-21	Automatic Restart Time	15-41	Power Section
8-32	Baud Rate	9-75	DO Identification	12-42	Slave Exception Message Count	14-22	Operation Mode	15-42	Voltage
8-33	Parity / Stop Bits	9-80	Defined Parameters (1)	12-8*	Other Ethernet Services	14-23	Typecode Setting	15-43	Software Version
8-34	Estimated cycle time	9-81	Defined Parameters (2)	12-80	FTP Server	14-25	Trip Delay at Torque Limit	15-44	Ordered Typecode String
8-35	Minimum Response Delay	9-82	Defined Parameters (3)	12-81	HTTP Server	14-26	Trip Delay at Inverter Fault	15-45	Actual Typecode String
8-36	Maximum Response Delay	9-83	Defined Parameters (4)	12-82	SMTP Service	14-28	Production Settings	15-46	Frequency Converter Ordering No
8-37	Maximum Inter-Char Delay	9-84	Defined Parameters (5)	12-89	Transparent Socket Channel Port	14-29	Service Code	15-47	Power Card Ordering No
8-4*	FC MC protocol set	9-90	Changed Parameters (1)	12-9*	Advanced Ethernet Services	14-3*	Current Limit Ctrl.	15-48	LCP Id No
8-40	Telegram Selection	9-91	Changed Parameters (2)	12-90	Cable Diagnostic	14-30	Current Lim Ctrl, Proportional Gain	15-49	SW ID Control Card
8-42	PCD Write Configuration	9-92	Changed Parameters (3)	12-91	Auto Cross Over	14-31	Current Lim Ctrl, Integration Time	15-50	SW ID Power Card
8-43	PCD Read Configuration	9-93	Changed Parameters (4)	12-92	IGMP Snooping	14-32	Current Lim Ctrl, Filter Time	15-51	Frequency Converter Serial Number
8-5*	Digital/Bus	9-94	Changed Parameters (5)	12-93	Cable Error Length	14-4*	Energy Optimising	15-53	Power Card Serial Number
8-50	Coasting Select	9-99	Profibus Revision Counter	12-94	Broadcast Storm Protection	14-40	VT Level	15-55	Vendor URL
8-52	DC Brake Select	11-**	LonWorks	12-95	Broadcast Storm Filter	14-41	AEO Minimum Magnetisation	15-56	Vendor Name
8-53	Start Select	11-0*	LonWorks ID	12-96	Port Config	14-42	Minimum AEO Frequency	15-59	CSIV Filename
8-54	Reversing Select	11-00	Neuron ID	12-98	Interface Counters	14-43	Motor Cosphi	15-6*	Option Ident
8-55	Set-up Select	11-1*	LON Functions	12-99	Media Counters	14-50	RFI Filter	15-60	Option Mounted
8-56	Preset Reference Select	11-10	Drive Profile	13-**	Smart Logic	14-51	DC Link Compensation	15-61	Option SW Version
8-7*	BACnet	11-15	LON Warning Word	13-0*	SLC Settings	14-52	Fan Control	15-62	Option Ordering No
8-70	BACnet Device Instance	11-17	XIF Revision	13-00	SL Controller Mode	14-53	Fan Monitor	15-63	Option Serial No
8-72	MS/TP Max Masters	11-18	LonWorks Revision	13-01	Start Event	14-55	Output Filter	15-70	Option in Slot A
8-73	MS/TP Max Info Frames	11-2*	LON Param. Access	13-02	Stop Event	14-59	Actual Number of Inverter Units	15-71	Slot A Option SW Version
8-74	"I-Am" Service	11-21	Store Data Values	13-03	Reset SLC	14-6*	Auto Derate	15-72	Option in Slot B
8-75	Initialisation Password	12-**	Ethernet	13-10	Comparator Operand	14-60	Function at Over Temperature	15-73	Slot B Option SW Version
8-8*	FC Port Diagnostics								

11 Product warranty

Commercial warranty

Warranty. For goods sold to commercial buyers, Seller warrants the goods sold to Buyer hereunder (with the exception of membranes, seals, gaskets, elastomer materials, coatings and other "wear parts" or consumables all of which are not warranted except as otherwise provided in the quotation or sales form) will be (i) be built in accordance with the specifications referred to in the quotation or sales form, if such specifications are expressly made a part of this Agreement, and (ii) free from defects in material and workmanship for a period of thirty-six (36) months from the date of installation or forty-two (42) months from the date of shipment (which date of shipment shall not be greater than thirty (30) days after receipt of notice that the goods are ready to ship), whichever shall occur first, unless a longer period is specified in the product documentation (the "Warranty").

Except as otherwise required by law, Seller shall, at its option and at no cost to Buyer, either repair or replace any product which fails to conform with the Warranty provided Buyer gives written notice to Seller of any defects in material or workmanship within ten (10) days of the date when any defects or non-conformance are first manifest. Under either repair or replacement option, Seller shall not be obligated to remove or pay for the removal of the defective product or install or pay for the installation of the replaced or repaired product and Buyer shall be responsible for all other costs, including, but not limited to, service costs, shipping fees and expenses. Seller shall have sole discretion as to the method or means of repair or replacement. Buyer's failure to comply with Seller's repair or replacement directions shall terminate Seller's obligations under this Warranty and render the Warranty void. Any parts repaired or replaced under the Warranty are warranted only for the balance of the warranty period on the parts that were repaired or replaced. Seller shall have no warranty obligations to Buyer with respect to any product or parts of a product that have been: (a) repaired by third parties other than Seller or without Seller's written approval; (b) subject to misuse, misapplication, neglect, alteration, accident, or physical damage; (c) used in a manner contrary to Seller's instructions for installation, operation and maintenance; (d) damaged from ordinary wear and tear, corrosion, or chemical attack; (e) damaged due to abnormal conditions, vibration, failure to properly prime, or operation without flow; (f) damaged due to a defective power supply or improper electrical protection; or (g) damaged resulting from the use of accessory equipment not sold or approved by Seller. In any case of products not manufactured by Seller, there is no warranty from Seller; however, Seller will extend to Buyer any warranty received from Seller's supplier of such products.

THE FOREGOING WARRANTY IS EXCLUSIVE AND IN LIEU OF ANY AND ALL OTHER EXPRESS OR IMPLIED WARRANTIES, GUARANTEES, CONDITIONS OR TERMS OF WHATEVER NATURE RELATING TO THE GOODS PROVIDED HEREUNDER, INCLUDING WITHOUT LIMITATION ANY IMPLIED WARRANTIES OF MERCHANTABILITY AND FITNESS FOR A PARTICULAR PURPOSE, WHICH ARE HEREBY EXPRESSLY DISCLAIMED AND EXCLUDED. EXCEPT AS OTHERWISE REQUIRED BY LAW, BUYER'S EXCLUSIVE REMEDY AND SELLER'S AGGREGATE LIABILITY FOR BREACH OF ANY OF THE FOREGOING WARRANTIES ARE LIMITED TO REPAIRING OR REPLACING THE PRODUCT AND SHALL IN ALL CASES BE LIMITED TO THE AMOUNT PAID BY THE BUYER FOR THE DEFECTIVE PRODUCT. IN NO EVENT SHALL SELLER BE LIABLE FOR ANY OTHER FORM OF DAMAGES, WHETHER DIRECT, INDIRECT, LIQUIDATED, INCIDENTAL, CONSEQUENTIAL, PUNITIVE, EXEMPLARY OR SPECIAL DAMAGES, INCLUDING BUT NOT LIMITED TO LOSS OF PROFIT, LOSS OF ANTICIPATED SAVINGS OR REVENUE, LOSS OF INCOME, LOSS OF BUSINESS, LOSS OF PRODUCTION, LOSS OF OPPORTUNITY OR LOSS OF REPUTATION.

Limited consumer warranty

Warranty. For goods sold for personal, family or household purposes, Seller warrants the goods purchased hereunder (with the exception of membranes, seals, gaskets, elastomer materials, coatings and other "wear parts" or consumables all of which are not warranted except as otherwise provided in the quotation or sales form) will be free from defects in material and workmanship for a period of thirty-six (36) months from the date of installation or forty-two (42) months from the product date code, whichever shall occur first, unless a longer period is provided by law or is specified in the product documentation (the "Warranty").

Except as otherwise required by law, Seller shall, at its option and at no cost to Buyer, either repair or replace any product which fails to conform with the Warranty provided Buyer gives written notice to Seller of any defects in material or workmanship within ten (10) days of the date when any defects or non-conformance are first manifest. Under either repair or replacement option, Seller shall not be obligated to remove or pay for the removal of the defective product or install or pay for the installation of the replaced or repaired product and Buyer shall be responsible for all other costs, including, but not limited to, service costs, shipping fees and expenses. Seller shall have sole discretion as to the method or means of repair or replacement. Buyer's failure to comply with Seller's repair or replacement directions shall terminate Seller's obligations under this Warranty and render this Warranty void. Any parts repaired or replaced under the Warranty are warranted only for the balance of the warranty period on the parts that were repaired or replaced. The Warranty is conditioned on Buyer giving written notice to Seller of any defects in material or workmanship of warranted goods within ten (10) days of the date when any defects are first manifest.

Seller shall have no warranty obligations to Buyer with respect to any product or parts of a product that have been: (a) repaired by third parties other than Seller or without Seller's written approval; (b) subject to misuse, misapplication, neglect, alteration, accident, or physical damage; (c) used in a manner contrary to Seller's instructions for installation, operation and maintenance; (d) damaged from ordinary wear and tear, corrosion, or chemical attack; (e) damaged due to abnormal conditions, vibration, failure to properly prime, or operation without flow; (f) damaged due to a defective power supply or improper electrical protection; or (g) damaged resulting from the use of accessory equipment not sold or approved by Seller. In any case of products not manufactured by Seller, there is no warranty from Seller; however, Seller will extend to Buyer any warranty received from Seller's supplier of such products.

THE FOREGOING WARRANTY IS PROVIDED IN PLACE OF ALL OTHER EXPRESS WARRANTIES. ALL IMPLIED WARRANTIES, INCLUDING BUT NOT LIMITED TO THE IMPLIED WARRANTIES OF MERCHANTABILITY AND FITNESS FOR A PARTICULAR PURPOSE, ARE LIMITED TO THIRTY-SIX (36) MONTHS FROM THE DATE OF INSTALLATION OR FORTY-TWO (42) MONTHS FROM THE PRODUCT DATE CODE, WHICHEVER SHALL OCCUR FIRST. EXCEPT AS OTHERWISE REQUIRED BY LAW, BUYER'S EXCLUSIVE REMEDY AND SELLER'S AGGREGATE LIABILITY FOR BREACH OF ANY OF THE FOREGOING WARRANTIES ARE LIMITED TO REPAIRING OR REPLACING THE PRODUCT AND SHALL IN ALL CASES BE LIMITED TO THE AMOUNT PAID BY THE BUYER FOR THE DEFECTIVE PRODUCT. IN NO EVENT SHALL SELLER BE LIABLE FOR ANY OTHER FORM OF DAMAGES, WHETHER DIRECT, INDIRECT, LIQUIDATED, INCIDENTAL, CONSEQUENTIAL, PUNITIVE, EXEMPLARY OR SPECIAL DAMAGES, INCLUDING BUT NOT LIMITED TO LOSS OF PROFIT, LOSS OF ANTICIPATED SAVINGS OR REVENUE, LOSS OF INCOME, LOSS OF BUSINESS, LOSS OF PRODUCTION, LOSS OF OPPORTUNITY OR LOSS OF REPUTATION.

Some states do not allow limitations on how long an implied warranty lasts, so the above limitation may not apply to you. Some states do not allow the exclusion or limitation of incidental or consequential damages, so the above exclusions may not apply to you. This warranty gives you specific legal rights, and you may also have other rights which may vary from state to state.

To make a warranty claim, check first with the dealer from whom you purchased the product or visit www.xylem.com for the name and location of the nearest dealer providing warranty service.

Xylem |'zīləm|

- 1) The tissue in plants that brings water upward from the roots;
- 2) a leading global water technology company.

We're a global team unified in a common purpose: creating advanced technology solutions to the world's water challenges. Developing new technologies that will improve the way water is used, conserved, and re-used in the future is central to our work. Our products and services move, treat, analyze, monitor and return water to the environment, in public utility, industrial, residential and commercial building services settings. Xylem also provides a leading portfolio of smart metering, network technologies and advanced analytics solutions for water, electric and gas utilities. In more than 150 countries, we have strong, long-standing relationships with customers who know us for our powerful combination of leading product brands and applications expertise with a strong focus on developing comprehensive, sustainable solutions.

For more information on how Xylem can help you, go to www.xylem.com



Xylem Inc.
2881 East Bayard St. Ext., Suite A
Seneca Falls, NY 13148
USA
Tel: (866) 673-0445
Fax: (888) 322-5877
www.xylem.com/centripro

Visit our Web site for the latest version of this document and more information

The original instruction is in English. All non-English instructions are translations of the original instruction.

© 2019 Xylem Inc

CentriPro is a trademark of Xylem Inc or one of its subsidiaries.

