



# AQUAVAR<sup>®</sup>

## Intelligent Pump Controller

150 HP - 600 HP

## INTRODUCTION

The **Aquavar®** Intelligent Pump Controller (IPC) is designed to provide variable frequency pumping control of speed, pressure, flow and level over a wide range of submersible and above ground applications. This Technical Brochure contains information for sizing and selection of the Aquavar IPC extension to include sizes from 150HP - 600HP. The higher horsepower extension includes the same software, programming, and troubleshooting procedures as the lower horsepower range. Here are just a few of the features and benefits of this versatile product:

- Application specific *"Start-Up Genie"* guides you through quick and easy commissioning
- Removable, graphical control panel with display
- Fully backlit display with large text makes the control pad easy to read
- Info key activates on board parameter and fault descriptions
- *My Personal Menu* allows user to focus on specific user selected and saved parameters
- Alarm Log key for quick access to alarms and maintenance events
- Alarm Log records the last 5 alarms
- Hand on, Auto on, and Off buttons for easy pump operation at the keypad - No toggling between local and remote operation!
- Modbus® RTU included in standard drive - Other communications available with option cards
- Duplex variable speed pumping control with auto lead/lag and alternate
- **USB Connectivity - Commission and monitor through PC software**
- Transducer assembly (0-300 psi) and 16' foot shielded cable
- Standard dual DC-link reactors - Reduces the level of harmonics similar to a 5% AC line reactor without the voltage drop across the full load range!
- EMC/RFI filters designed to reduce drive noise emissions and interference to strict standards.
- **Automatic Motor Adaption - For optimized performance and efficiency**
- **Automized Energy Optimization - Regulates output voltage to improve system efficiency as loads change**
- Protects the pump from damage due to cavitation, dead head and blocked suction.
- Helps protect the motor from short circuit, phase loss, overload, undervoltage, overvoltage
- Large connection area allows more space for incoming power and motor wiring

## TRANSDUCER

**Includes:** 4-20mA, 300psi transducer and 16' cable

**Used for:** Pressure transducer for constant pressure applications.  
Transducer will be delivered with your drive when you use the "1" Transducer character.

**NOTE:** 9K712 - Repair part number for the transducer  
9K755 - Repair part number for the transducer and 16' cable



KEYPAD LAYOUT

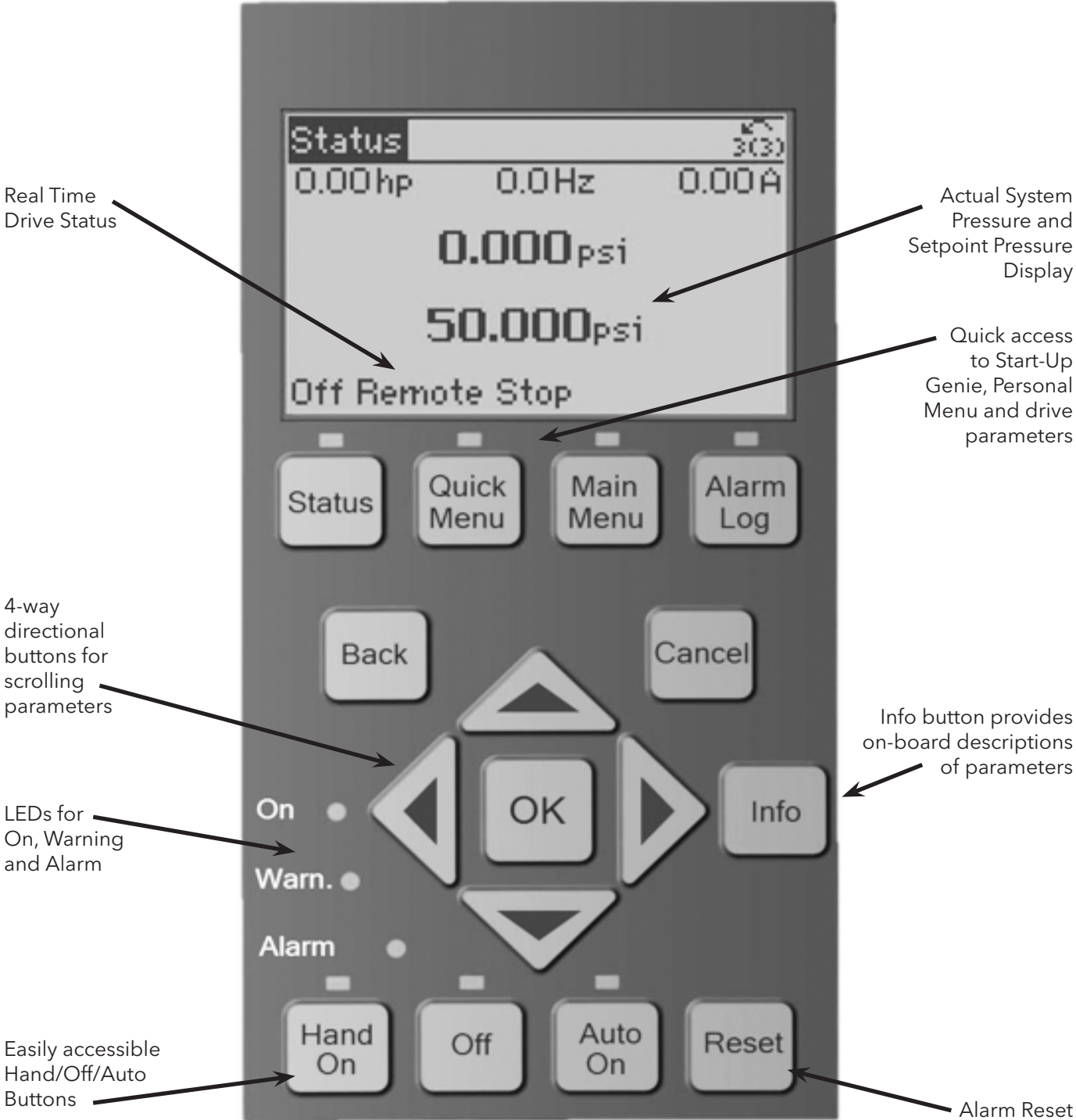

### NOMENCLATURE

#### Example Product Code

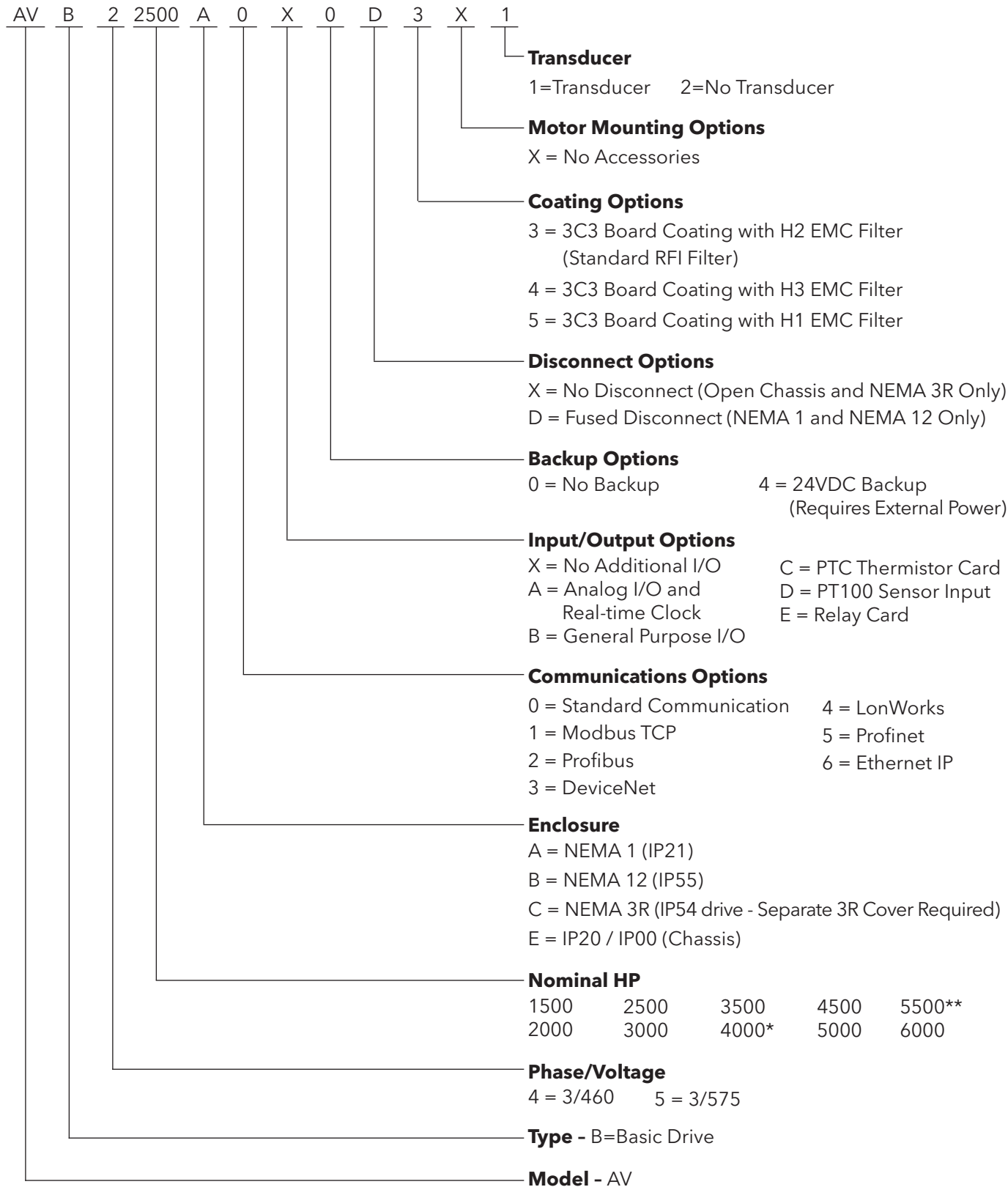

\* Available on 575V only.  
\*\* Available on 460V only.

### PRODUCT CHART - IP20/IP00 CHASSIS

INPUT VOLTAGE	INPUT PHASE	IP20 CHASSIS BASE MODEL	CONTINUOUS OUTPUT AMPS* @ 45°C (113°F) Ambient	CONTINUOUS OUTPUT AMPS* @ 50°C (122°F) Ambient	NOMINAL SURFACE MOTOR HP**	FRAME SIZE
460	3	AVB41500E0X0X3X2	190	175	150	D3
		AVB42000E0X0X3X2	240	221	200	
		AVB42500E0X0X3X2	302	278	250	
		AVB43000E0X0X3X2	361	332	300	D4
		AVB43500E0X0X3X2	443	408	350	
		AVB44500E0X0X3X2	535	492	450	
		AVB45000E0X0X3X2	590	543	500	E2
		AVB45500E0X0X3X2	678	624	550	
AVB46000E0X0X3X2		730	672	600	575	
AVB51500E0X0X3X2		155	143	150		D3
AVB52000E0X0X3X2		192	177	200		
AVB52500E0X0X3X2		242	223	250		D4
AVB53000E0X0X3X2		290	267	300		
AVB53500E0X0X3X2		344	316	350		
AVB54000E0X0X3X2		400	368	400		E2
AVB54500E0X0X3X2		450	414	450		
AVB55000E0X0X3X2	500	460	500			
AVB56000E0X0X3X2	570	524	600			

\* With Switching Frequency (Parameter 14-10) set to 2 kHz.

\*\* Nominal HP values are for reference only. Size Aquavar by maximum output amps of the motor.

### PRODUCT CHART - NEMA 1

INPUT VOLTAGE	INPUT PHASE	NEMA 1 BASE MODEL	CONTINUOUS OUTPUT AMPS* @ 45°C (113°F) Ambient	CONTINUOUS OUTPUT AMPS* @ 50°C (122°F) Ambient	NOMINAL SURFACE MOTOR HP**	FRAME SIZE
460	3	AVB41500A0X0D3X1	190	175	150	D5
		AVB42000A0X0D3X1	240	221	200	
		AVB42500A0X0D3X1	302	278	250	
		AVB43000A0X0D3X1	361	332	300	D7
		AVB43500A0X0D3X1	443	408	350	
		AVB44500A0X0D3X1	535	492	450	
		AVB45000A0X0D3X1	590	543	500	E1
		AVB45500A0X0D3X1	678	624	550	
AVB46000A0X0D3X1		730	672	600	575	
AVB51500A0X0D3X1		155	143	150		D5
AVB52000A0X0D3X1		192	177	200		
AVB52500A0X0D3X1		242	223	250		D7
AVB53000A0X0D3X1		290	267	300		
AVB53500A0X0D3X1		344	316	350		
AVB54000A0X0D3X1		400	368	400		E1
AVB54500A0X0D3X1		450	414	450		
AVB55000A0X0D3X1	500	460	500			
AVB56000A0X0D3X1	570	524	600			

\* With Switching Frequency (Parameter 14-10) set to 2 kHz.

\*\* Nominal HP values are for reference only. Size Aquavar by maximum output amps of the motor.

### PRODUCT CHART - NEMA 12

INPUT VOLTAGE	INPUT PHASE	NEMA 12 BASE MODEL	CONTINUOUS OUTPUT AMPS* @ 45°C (113°F) Ambient	CONTINUOUS OUTPUT AMPS* @ 50°C (122°F) Ambient	NOMINAL SURFACE MOTOR HP**	FRAME SIZE
460	3	AVB41500B0X0D3X1	190	175	150	D5
		AVB42000B0X0D3X1	240	221	200	
		AVB42500B0X0D3X1	302	278	250	
		AVB43000B0X0D3X1	361	332	300	D7
		AVB43500B0X0D3X1	443	408	350	
		AVB44500B0X0D3X1	535	492	450	
		AVB45000B0X0D3X1	590	543	500	E1
		AVB45500B0X0D3X1	678	624	550	
AVB46000B0X0D3X1		730	672	600		
575		AVB51500B0X0D3X1	155	143	150	D5
		AVB52000B0X0D3X1	192	177	200	D7
		AVB52500B0X0D3X1	242	223	250	
		AVB53000B0X0D3X1	290	267	300	
		AVB53500B0X0D3X1	344	316	350	E1
		AVB54000B0X0D3X1	400	368	400	
		AVB54500B0X0D3X1	450	414	450	
	AVB55000B0X0D3X1	500	460	500		
AVB56000B0X0D3X1	570	524	600			

\* With Switching Frequency (Parameter 14-10) set to 2 kHz.

\*\* Nominal HP values are for reference only. Size Aquavar by maximum output amps of the motor.

### PRODUCT CHART - NEMA 3R

INPUT VOLTAGE	INPUT PHASE	NEMA 3R BASE MODEL	CONTINUOUS OUTPUT AMPS* @ 45°C (113°F) Ambient	CONTINUOUS OUTPUT AMPS* @ 50°C (122°F) Ambient	NOMINAL SURFACE MOTOR HP**	FRAME SIZE	NEMA 3R Cover Kit Part Number***	DV / DT Load Filter NEMA 3R****
460	3	AVB41500C0X0X3X1	167	143	150	D1	9K715	V1K200A03
		AVB42000C0X0X3X1	211	180	200			V1K250A03
		AVB42500C0X0X3X1	266	227	250			V1K305A03
		AVB43000C0X0X3X1	318	271	300	D2	9K716	V1K362A03
		AVB43500C0X0X3X1	390	332	350			V1K420A03
		AVB44500C0X0X3X1	475	405	450			V1K480A03
575		AVB51500C0X0X3X1	136	116	150	D1	9K715	V1K160A03
		AVB52000C0X0X3X1	169	144	200			V1K200A03
		AVB52500C0X0X3X1	213	182	250	D2	9K716	V1K250A03
		AVB53000C0X0X3X1	255	218	300			V1K305A03
		AVB53500C0X0X3X1	303	258	350			
		AVB54000C0X0X3X1	352	300	400			V1K362A03

\* With Switching Frequency (Parameter 14-10) set to 4 kHz.

\*\* Nominal HP values are for reference only. Size Aquavar by maximum output amps of the motor.

\*\*\* NEMA 3R Cover Kit is required to be used with the base model number for NEMA 3R outdoor protection.

\*\*\*\* dv/dt filter recommended for applications with motor leads longer than 50'.

**SPECIFICATIONS****Ratings and Enclosures**  

- IP20/IP00 Chassis, TYPE 1, TYPE 12, TYPE 3R
- 150 - 600 HP (frame D - E) wall or floor mounted
- Relative humidity lower than 95% without condensation.
- Ambient temperature 14° F - 113° F (-10°C - 45°C). Higher temperatures can be achieved by derating the output amperage of the drive for up to 122° F (50°C).
- At altitudes from 0 to 1000 meters (0 to 3300 feet) rated current is available. For altitudes above 1000 meters (3300 feet) use table listed below. Maximum 3000 meters (9900 feet). (Consult factory above 3000 meters (9900 feet)). See chart below for derate in % of output current.

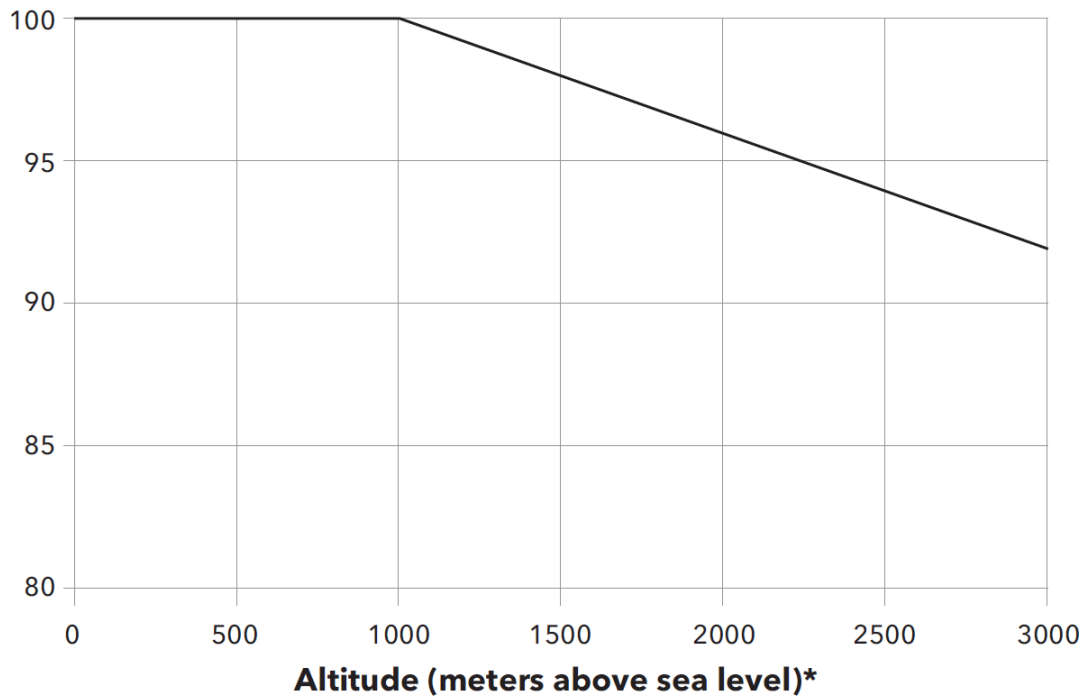
**I<sub>OUT</sub>(%)****Electrical Characteristics**

- INPUT POWER**
- 3 phase 380 V to 480 V ±10%
  - 3 phase 525 V to 690 V ±10%
  - Frequency 50 or 60 Hz, ±2Hz

- OUTPUT POWER**
- 3 phase from 0 to V<sub>supply</sub>
  - 0 to 120 Hz frequency

### BUILT-IN CONTROL CONNECTIONS

Analog input .....	1 current (0/4-20mA); 1 current/voltage (0/4-20mA/0-10vdc)
Programmable digital inputs .....	6, 2 can be used as digital outputs
Analog output .....	1, 0/4-20 mA
Programmable relay outputs .....	2, standard Form C, 240 VAC, 2 A
Auxiliary voltage .....	+24 V DC, maximum 200 mA

### PUMP AND MOTOR PROTECTIONS

#### Motor Protections

- Ground Fault
- Motor Stall
- Motor Over Temperature (Predictive and Sensor Based)
- Motor Condensation (Motor Preheat Circuit)
- Motor Overload (Programmable Action)

#### Pump Protections

- Pump No-Flow
- Under Pressure
- No Water / Loss of Prime
- Short-Cycle
- Vibration (Programming Automated)

### NEMA 3R COVER KIT

The NEMA 3R Cover Kits are designed for NEMA 3R base model drives with AVBXXXXXC... part numbers. These kits add a cover to the outside vents of the IPC and provides NEMA 3R compliant protection against weather and hosed water. The kit is used only with IPC drives that have the enclosure code "C".

The NEMA 3R Cover Kit includes:

- Top Plate
- Gland plate with attached gasket
- NEMA 3R Cover
- Adhesive label
- Installation hardware

Cover Kit Selection:

Frame Size	Ordering Number
D1	9K715
D2	9K716

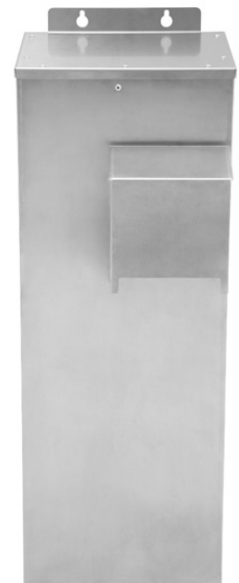

Aquavar expansion cards can be included in the drive using the smart part number on page 4. Expansion cards can also be ordered as a field installable option using the "K" part numbers listed.

### COMMUNICATION OPTIONS (Repair Part Number)

Modbus TCP (9K667)	DeviceNet (9K669)	Profinet (9K671)
Profibus (9K668)	LonWorks (9K670)	Ethernet IP (9K672)

### INPUT/OUTPUT OPTIONS (Repair Part Number)

#### ANALOG I/O CARD (9K653)

Includes: 3 Analog IN for 0 - 10VDC

OR

0-20mA\*

4-20mA\*

Ni1000 Temperature Sensor

Pt1000 Temperature Sensor

3 Analog OUT for 0 - 10VDC

Battery backup for real-time clock

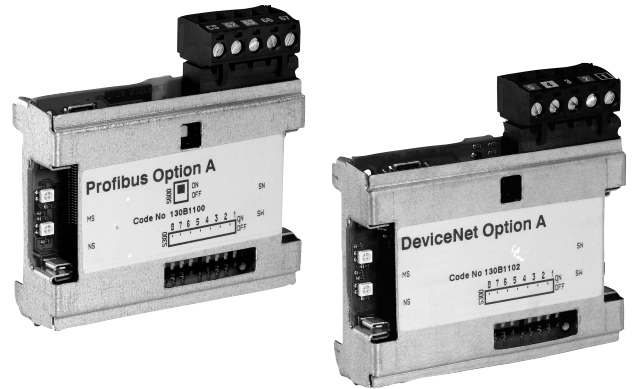

Used for: Providing battery backup of clock function during loss of power (real-time clock is native to the drive, and will reset to zero during power outage without Analog I/O card.)

Extension of analog I/O on control card (multi zone with 3 sensors)

Extended PID controllers with I/O's (set point inputs, sensor inputs and outputs)

AIN	GND	AIN	GND	AIN	GND	AOUT 0-10VDC	GND	AOUT 0-10VDC	GND	AOUT 0-10VDC	GND
1	2	3	4	5	6	7	8	9	10	11	12

\* Requires 510Ω resistor

#### GENERAL I/O CARD (9K654)

Includes: 3 Digital IN, 2 Digital OUT, 2 Analog IN (voltage), 1 Analog OUT (current)

Used for: Extension of number of digital and analog inputs and outputs

COM	DIN	DIN7	DIN8	DIN9	GND(1)	DOUT3	DOUT4	AOUT2	24V	GND(2)	AIN3	AIN4
<b>X30/</b>	1	2	3	4	5	6	7	8	9	10	11	12

**INPUT/OUTPUT OPTIONS** *(continued)*

**PTC THERMISTOR CARD (9K656)**

Includes: Twelve terminal PTC card

Used for: Monitor temperature of electric motor with PTC thermistor input (PTC Thermistor Card option is Certified for ATEX for use with motors in potentially explosive atmospheres.)

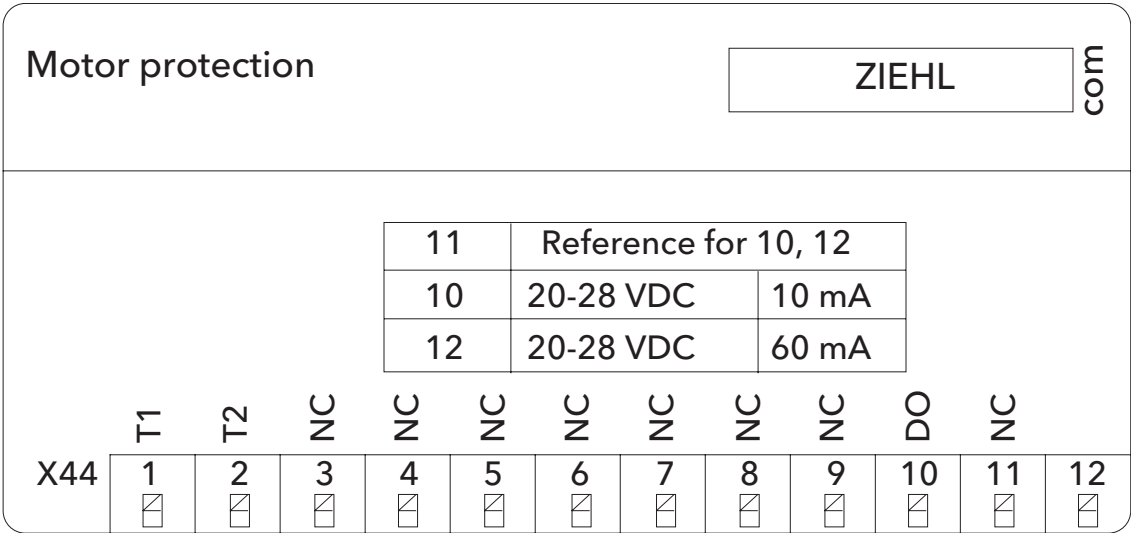

**PT100 SENSOR INPUT CARD (9K657)**

Includes: Twelve terminal PTC100 card

Used for: Sensor Input for PT100 and PT1000 temperature sensors for motor bearing temperatures

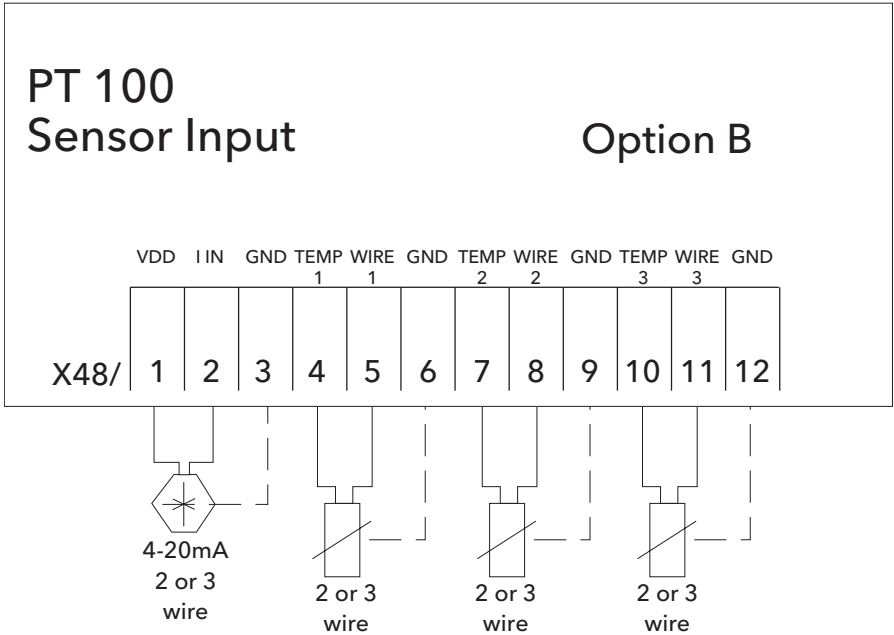

**INPUT/OUTPUT OPTIONS** (continued)

**RELAY CARD (9K658)**

Includes: 3 standard Form C, 240 VAC, 2 A

Used for: Extension of the number of output relays

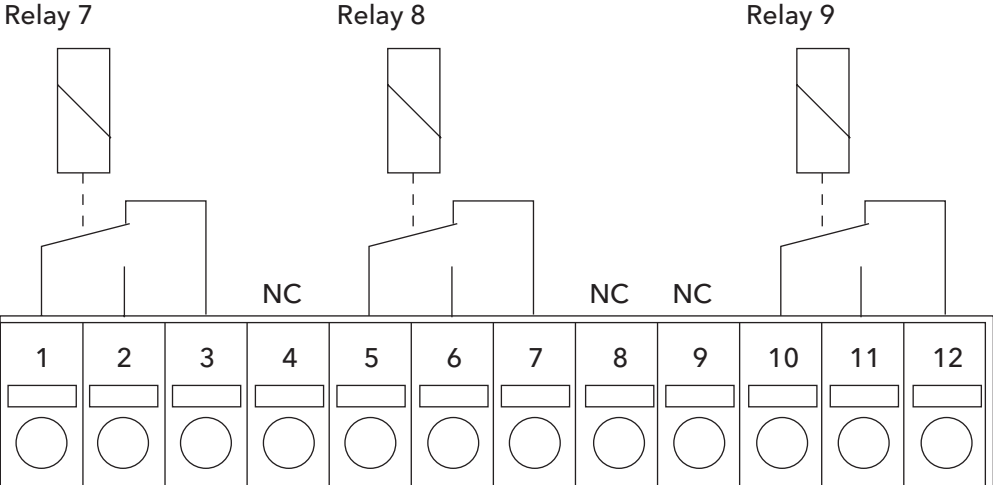

**BACKUP OPTIONS**

**24VDC BACKUP (9K659)**

Includes: Pos and Neg Terminals for 24VDC

Used for: Interface to external 24 VDC auxiliary power supply (Enables full LCP operation without line voltage supplied).

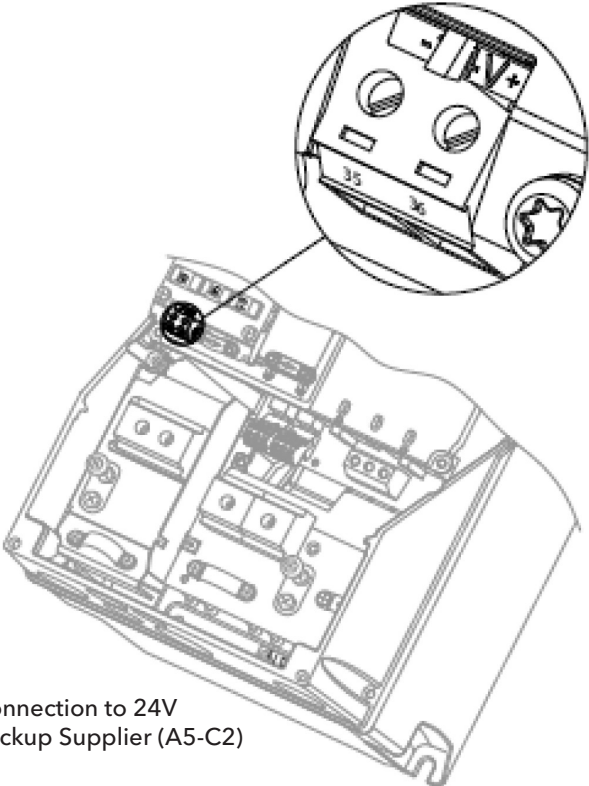

Connection to 24V Backup Supplier (A5-C2)

**COATING/EMC FILTER OPTIONS****3C3 BOARD COATING**

**Includes:** Additional protection for printed circuit board (PCB) above the standard protection to 3C2.

**Used for:** Aggressive environments where drive may be subject to corrosive gases.

**NOTE:** THIS IS NOT A SUBSTITUTE FOR SIZING THE PROPER ENCLOSURE.  
ENCLOSURE SHOULD BE SELECTED BASED UPON ENVIRONMENT.

**EMC OPTIONS**

**Includes:** H2 filter (EN 55011 Class A2) standard on all models except 575V and single phase, 10, 20 and 30 HP. 575V and single phase, 10, 20 and 30 HP drives are not available with EMC filter.

**Options:** H1 or H3 (EN 55011 Class A1/B)

**Used for:** Increased level of EMC and RFI noise dampening

**DV/DT FILTERS\*** (ORDER SEPARATELY)

**Includes:** NEMA 3R dv/dt filter

**Used for:** Provides motor protection by limiting voltage spikes below 1,000 volts for long lead (submersible) applications.

**FEATURES:**

- 2 - 130 amps; 240V - 600V; 2 - 125HP
- NEMA 3R Enclosure
- Carrier Frequency: 1 - 12 kHz
- Fundamental Frequency: 0 - 60Hz
- Efficiency: > 98%
- Insulation Rating 600V Class
- Agency Approvals: UL, cUL
- Maximum Altitude: 6,000 feet
  - (Derate for applications above 6,000 feet)

\* dv/dt filters are recommended on all pumping applications with Motor leads longer than 50'



DV / DT filters have been sized in the outdoor rated Product Charts (Page 8). DV /DT filters to be ordered separately to mount near the drive.

DIMENSIONS

D1 ENCLOSURE, CABINET MOUNT - Dimensions in mm (in.)

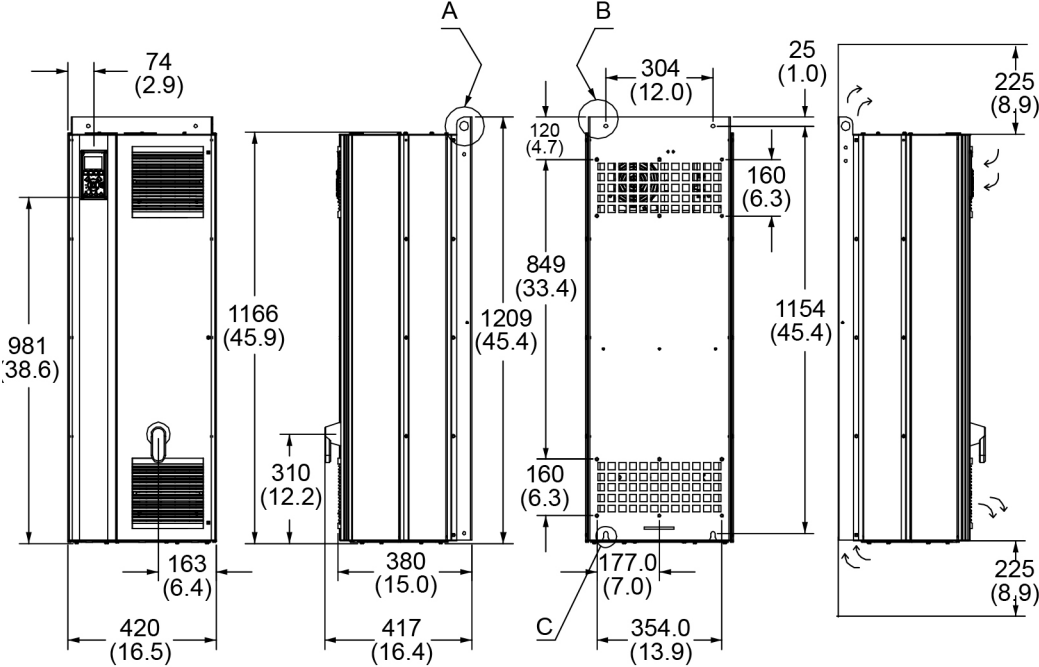

D2 ENCLOSURE, CABINET MOUNT - Dimensions in mm (in.)

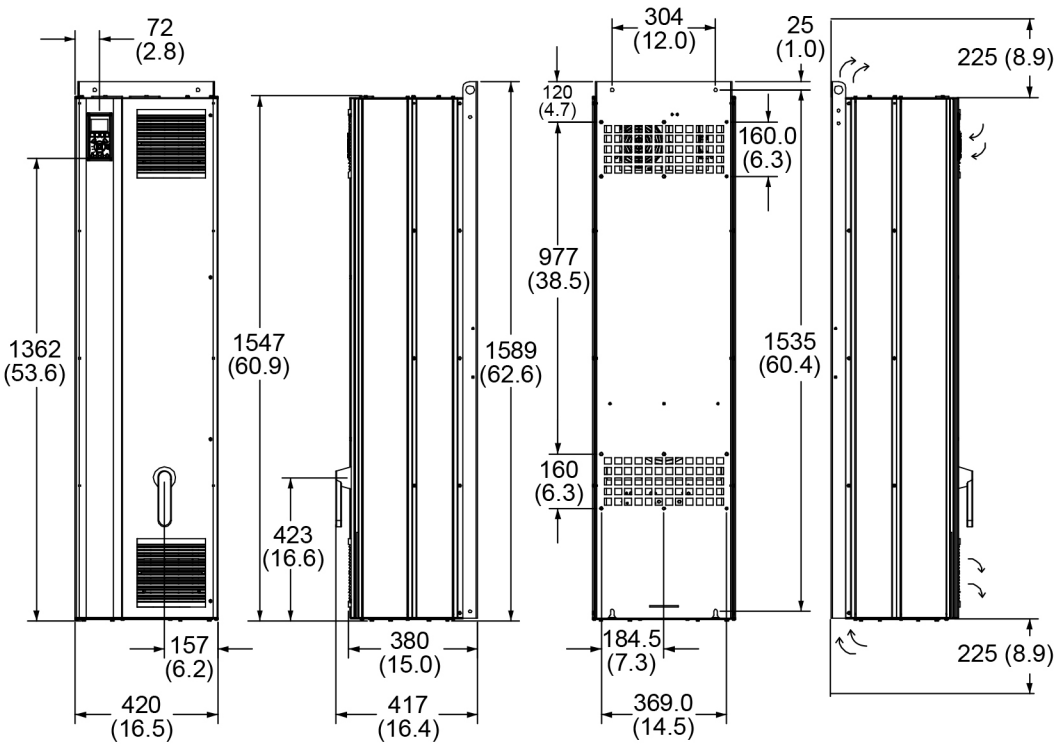

### DIMENSIONS

#### EXTERIOR DIMENSIONS FOR D1H WITH NEMA 3R KIT (9K715) - Dimensions in mm (in.)

Please note airflow directions

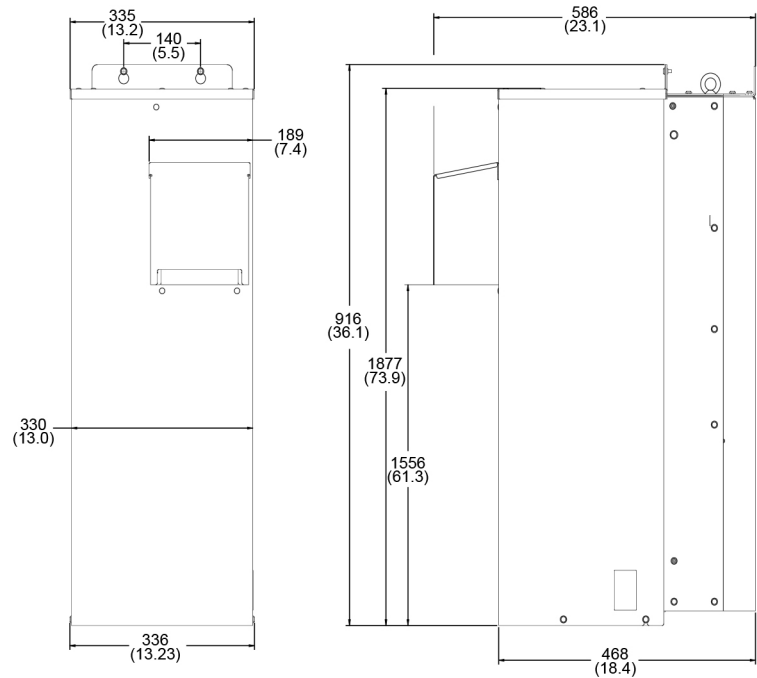

#### EXTERIOR DIMENSIONS FOR D2H WITH NEMA 3R KIT (9K716) - Dimensions in mm (in.)

Please note airflow directions

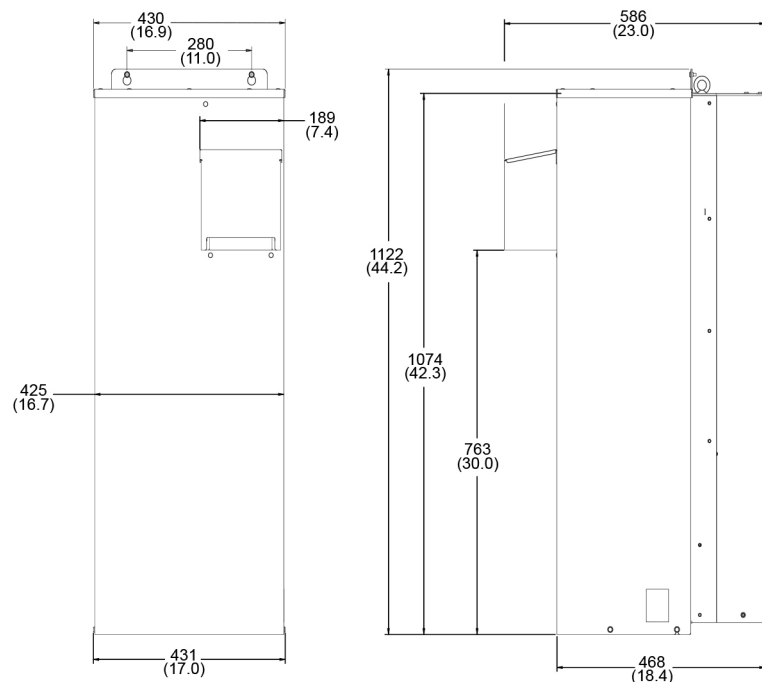

### DIMENSIONS

D3 ENCLOSURE, CABINET MOUNT - Dimensions in mm (in.)

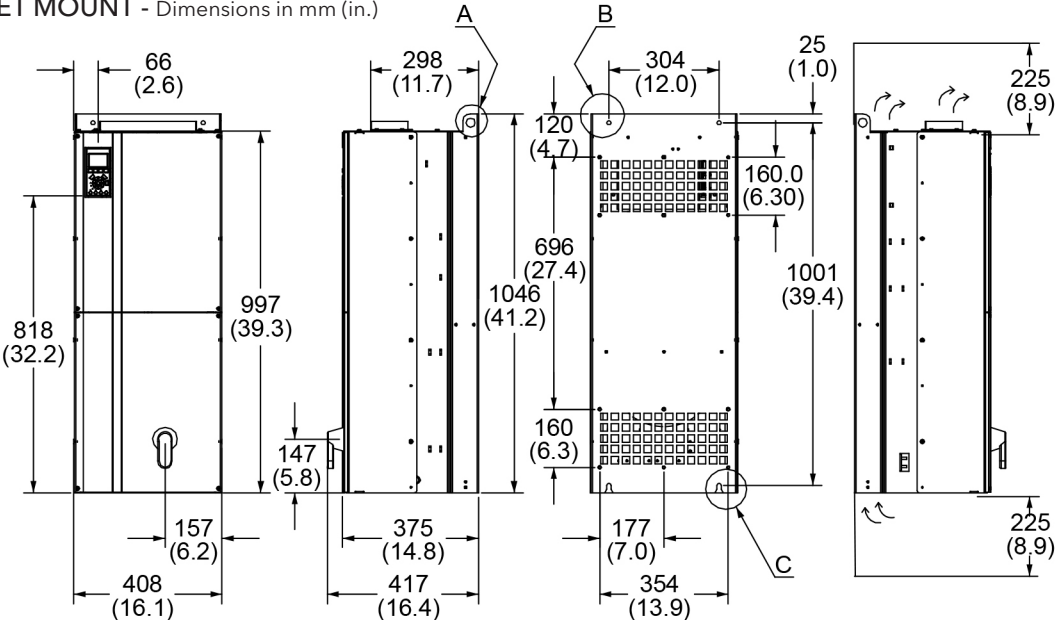

D4 ENCLOSURE, CABINET MOUNT - Dimensions in mm (in.)

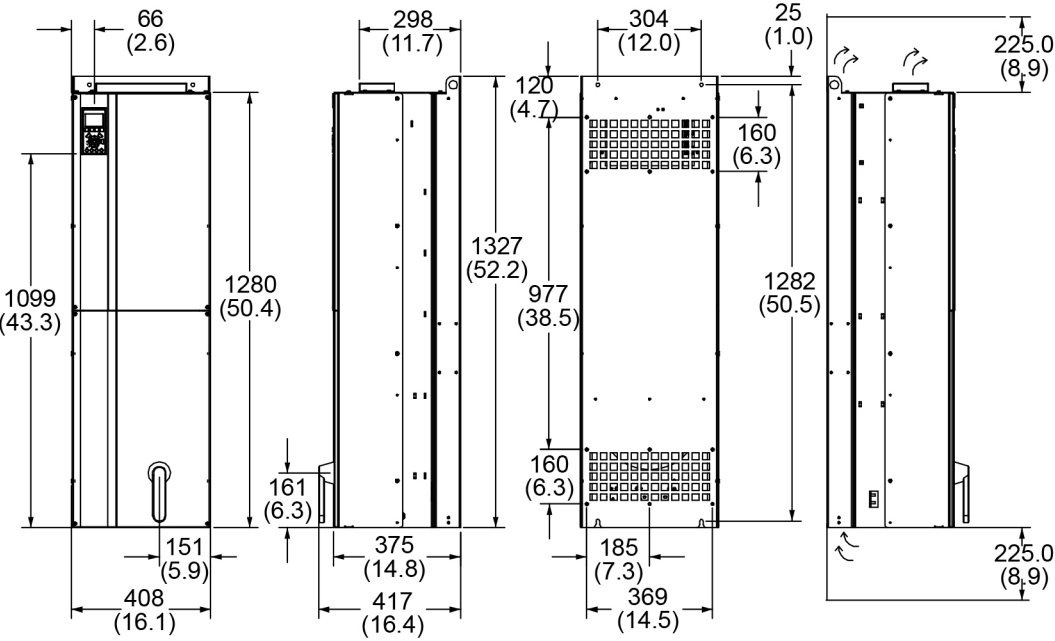

### IP00/IP21/IP54 – ALL SIZES

Please note airflow directions

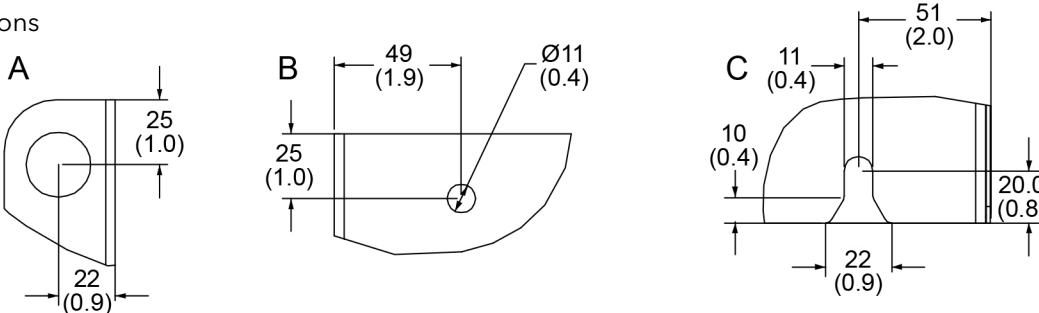

## Residential Water Systems

### DIMENSIONS

#### D5 ENCLOSURE - Dimensions in mm (in.)

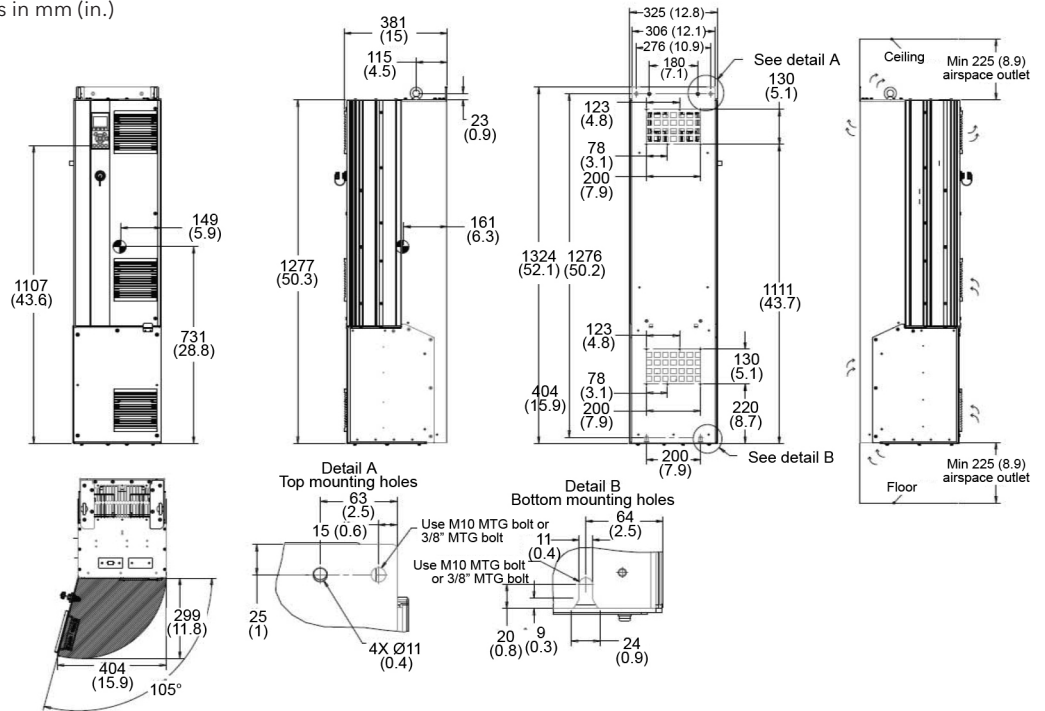

#### D7 ENCLOSURE - Dimensions in mm (in.)

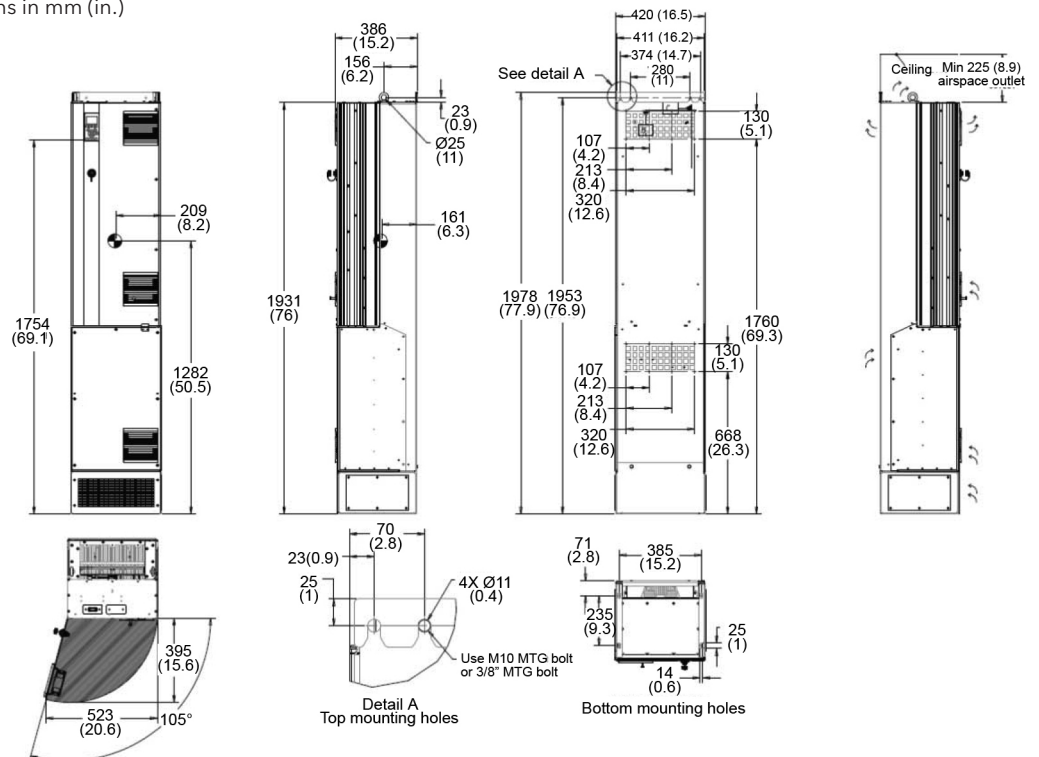

### DIMENSIONS

#### E1 ENCLOSURE, FLOOR- OR CABINET-MOUNT - Dimensions in mm (in.)

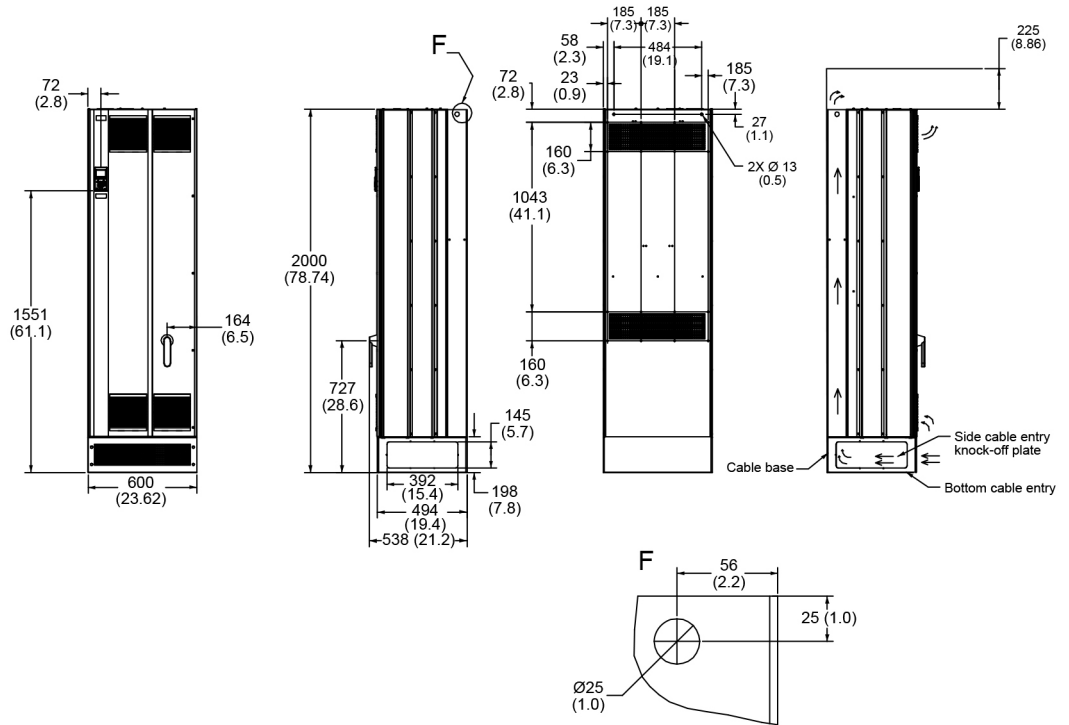

#### E2 ENCLOSURE, FLOOR- OR CABINET-MOUNT - Dimensions in mm (in.)

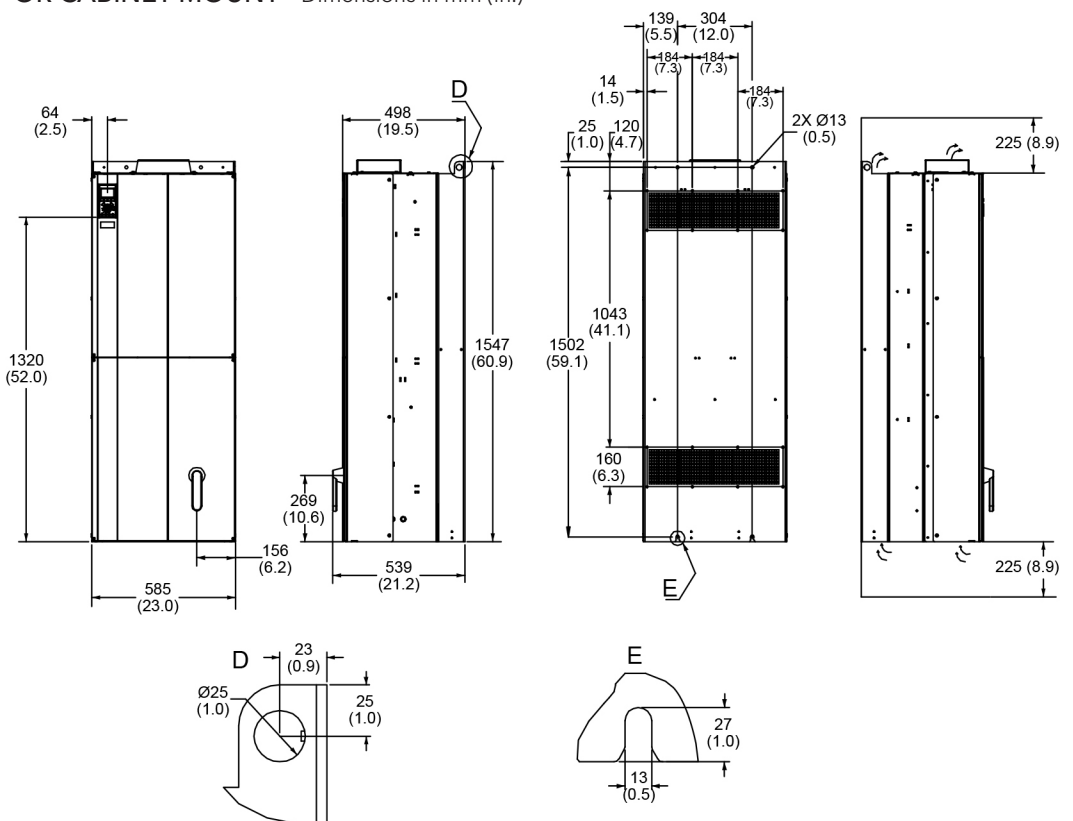

**NOTES**

### NOTES

# Xylem |'zīləm|

- 1) The tissue in plants that brings water upward from the roots;
- 2) a leading global water technology company.

We're a global team unified in a common purpose: creating advanced technology solutions to the world's water challenges. Developing new technologies that will improve the way water is used, conserved, and re-used in the future is central to our work. Our products and services move, treat, analyze, monitor and return water to the environment, in public utility, industrial, residential and commercial building services settings. Xylem also provides a leading portfolio of smart metering, network technologies and advanced analytics solutions for water, electric and gas utilities. In more than 150 countries, we have strong, long-standing relationships with customers who know us for our powerful combination of leading product brands and applications expertise with a strong focus on developing comprehensive, sustainable solutions.

**For more information on how Xylem can help you, go to [www.xylem.com](http://www.xylem.com)**



Xylem Inc.  
Phone: (866) 673-0428  
Fax: (888) 322-5877  
[www.xylem.com](http://www.xylem.com)

Xylem is a registered trademark of Xylem Inc. or one of its subsidiaries. All other trademarks or registered trademarks are property of their respective owners.  
© 2024 Xylem Inc. BCPAQHHP R3 August 2024