

JOB:	REPRESENTATIVE:	
UNIT TAG:	ORDER NO.:	DATE:
ENGINEER:	SUBMITTED BY:	DATE:
CONTRACTOR:	APPROVED BY:	DATE:

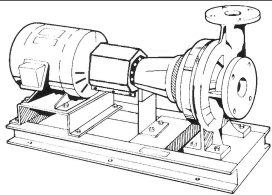

5-13B

Marlow Series e-530SL

Centrifugal Pumps - Base Mounted

SPECIFICATIONS

FLOW _____ HEAD _____

HP _____ RPM _____

VOLTS _____

CYCLE _____ PHASE _____

ENCLOSURE _____

APPROX. WEIGHT _____

SPECIALS _____

MATERIALS OF CONSTRUCTION

Stainless Steel Fitted

FEATURES

- ANSI/OSHA Coupling Guard
- Center Drop Out Spacer Coupling
- Fabricated Heavy Duty Baseplate

MAXIMUM WORKING PRESSURE

175 psi (12 bar) W.P.
 w/ 125# ANSI flange drilling

TYPE OF SEAL

- Standard Seal (Buna-Carbon/Ceramic)
- F Standard Seal w/ Flush Line (Buna-Carbon/Ceramic)
- S Stuffing Box Construction w/ Flushed Mechanical Single Seal (EPR-Tungsten Carbide/Carbon)
- PF Stuffing Box Construction w/ Packing (Graphite Impregnated Teflon)

Note: Equipped with NEOPRENE coupling

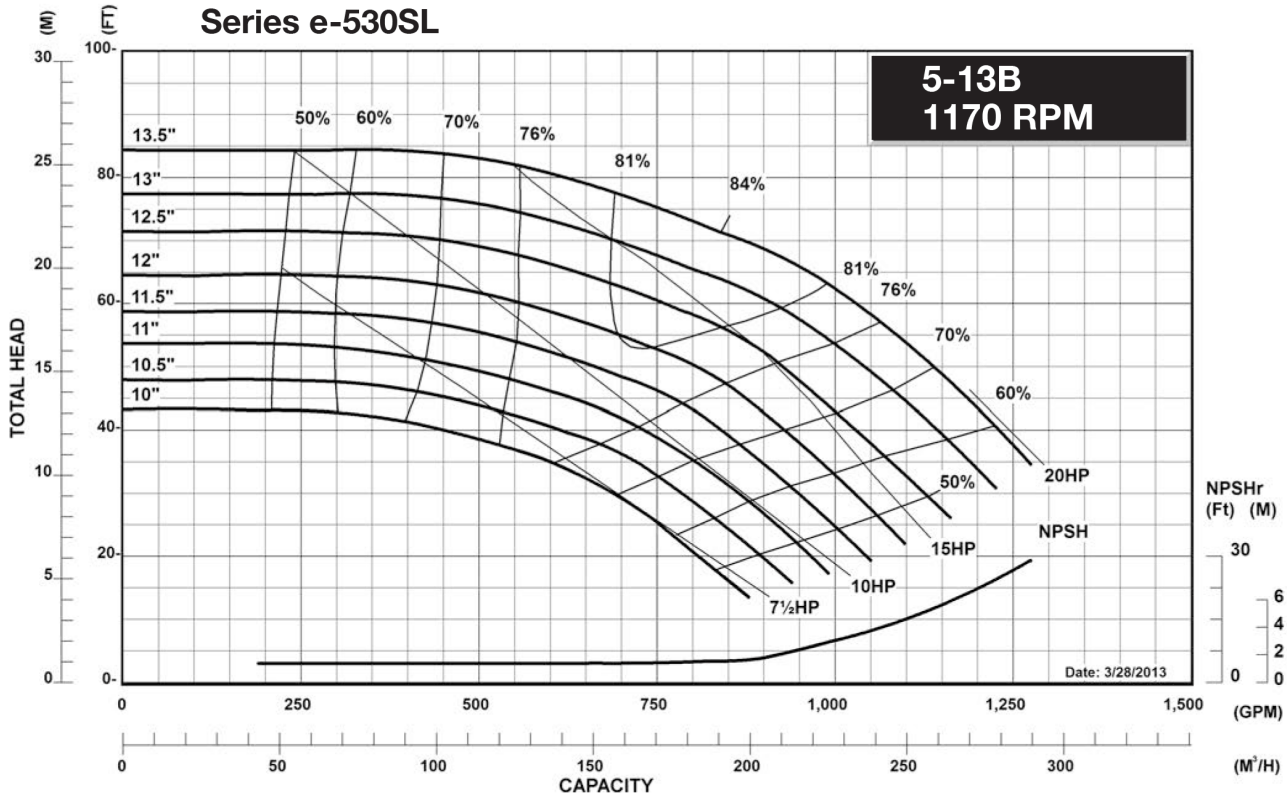

JOB:	REPRESENTATIVE:	
UNIT TAG:	ORDER NO.:	DATE:
ENGINEER:	SUBMITTED BY:	DATE:
CONTRACTOR:	APPROVED BY:	DATE:

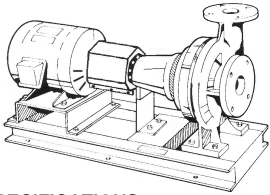

5-13B

Marlow Series e-530SL

Centrifugal Pumps - Base Mounted

SPECIFICATIONS

FLOW _____ HEAD _____

HP _____ RPM _____

VOLTS _____

CYCLE _____ PHASE _____

ENCLOSURE _____

APPROX. WEIGHT _____

SPECIALS _____

MATERIALS OF CONSTRUCTION

Stainless Steel Fitted

FEATURES

- ANSI/OSHA Coupling Guard
- Center Drop Out Spacer Coupling
- Fabricated Heavy Duty Baseplate

MAXIMUM WORKING PRESSURE

175 psi (12 bar) W.P.
w/ 125# ANSI flange drilling

TYPE OF SEAL

- Standard Seal (Buna-Carbon/Ceramic)
- F Standard Seal w/ Flush Line (Buna-Carbon/Ceramic)
- S Stuffing Box Construction w/ Flushed Mechanical Single Seal (EPR-Tungsten Carbide/Carbon)
- PF Stuffing Box Construction w/ Packing (Graphite Impregnated Teflon)

Note: Equipped with NEOPRENE coupling

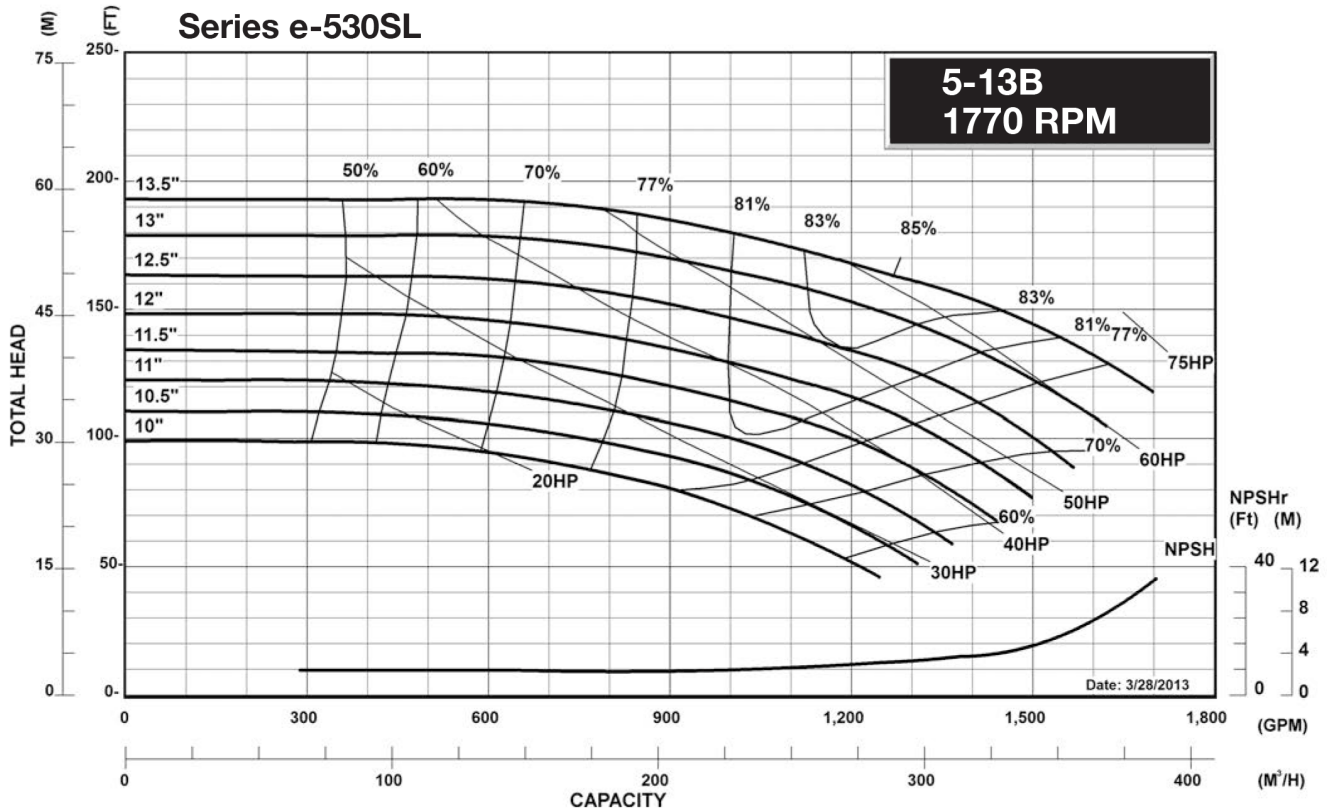

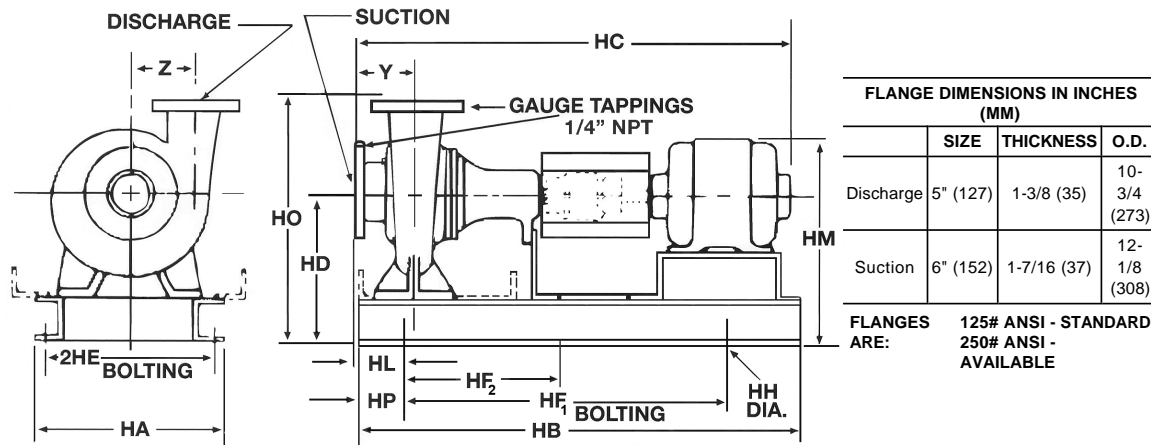

DIMENSIONS - Inches (mm)

STANDARD SEAL

MOTOR FRAME	HA	HB	HC MAX	HD	2HE	HF ₁	HF ₂	HH	HL	HM MAX	HO	HP	Y	Z
	"L" FRAME													
254T	24 (610)	56 (1422)	47-1/8 (1197)	16-1/2 (419)	21-1/2 (546)	44 (1118)	22 (559)	1 (25)	5-7/16 (138)	23-3/8 (594)	29-1/2 (749)	6 (152)	6 (152)	9 (229)
256T	24 (610)	56 (1422)	48-7/8 (1241)	16-1/2 (419)	21-1/2 (546)	44 (1118)	22 (559)	1 (25)	5-7/16 (138)	23-3/8 (594)	29-1/2 (749)	6 (152)	6 (152)	9 (229)
284T	24 (610)	56 (1422)	49-7/8 (1267)	16-1/2 (419)	21-1/2 (546)	44 (1118)	22 (559)	1 (25)	5-7/16 (138)	24-1/2 (622)	29-1/2 (749)	6 (152)	6 (152)	9 (229)
286T	24 (610)	56 (1422)	51-3/8 (1305)	16-1/2 (419)	21-1/2 (546)	44 (1118)	22 (559)	1 (25)	5-7/16 (138)	24-1/2 (622)	29-1/2 (749)	6 (152)	6 (152)	9 (229)
324T	24 (610)	56 (1422)	53-3/8 (1356)	16-1/2 (419)	21-1/2 (546)	44 (1118)	22 (559)	1 (25)	5-7/16 (138)	25-5/8 (651)	29-1/2 (749)	6 (152)	6 (152)	9 (229)
326T	24 (610)	56 (1422)	54-7/8 (1394)	16-1/2 (419)	21-1/2 (546)	44 (1118)	22 (559)	1 (25)	5-7/16 (138)	25-5/8 (651)	29-1/2 (749)	6 (152)	6 (152)	9 (229)
364T	24 (610)	56 (1422)	57-1/8 (1451)	16-1/2 (419)	21-1/2 (546)	44 (1118)	22 (559)	1 (25)	5-7/16 (138)	26-3/4 (679)	29-1/2 (749)	6 (152)	6 (152)	9 (229)
365T	24 (610)	56 (1422)	58-1/8 (1476)	16-1/2 (419)	21-1/2 (546)	44 (1118)	22 (559)	1 (25)	5-7/16 (138)	26-3/4 (679)	29-1/2 (749)	6 (152)	6 (152)	9 (229)

STUFFING BOX

MOTOR FRAME	HA	HB	HC MAX	HD	2HE	HF ₁	HF ₂	HH	HL	HM MAX	HO	HP	Y	Z
	"L" FRAME													
254T	24 (610)	56 (1422)	49-1/2 (1257)	16-1/2 (419)	21-1/2 (546)	44 (1118)	22 (559)	1 (25)	5-7/16 (138)	23-3/8 (594)	29-1/2 (749)	6 (152)	6 (152)	9 (229)
256T	24 (610)	56 (1422)	51-1/4 (1302)	16-1/2 (419)	21-1/2 (546)	44 (1118)	22 (559)	1 (25)	5-7/16 (138)	23-3/8 (594)	29-1/2 (749)	6 (152)	6 (152)	9 (229)
284T	24 (610)	56 (1422)	52-1/4 (1327)	16-1/2 (419)	21-1/2 (546)	44 (1118)	22 (559)	1 (25)	5-7/16 (138)	24-1/2 (622)	29-1/2 (749)	6 (152)	6 (152)	9 (229)
286T	24 (610)	56 (1422)	53-3/4 (1365)	16-1/2 (419)	21-1/2 (546)	44 (1118)	22 (559)	1 (25)	5-7/16 (138)	24-1/2 (622)	29-1/2 (749)	6 (152)	6 (152)	9 (229)
324T	24 (610)	56 (1422)	55-3/4 (1416)	16-1/2 (419)	21-1/2 (546)	44 (1118)	22 (559)	1 (25)	5-7/16 (138)	25-5/8 (651)	29-1/2 (749)	6 (152)	6 (152)	9 (229)
326T	24 (610)	56 (1422)	57-1/4 (1454)	16-1/2 (419)	21-1/2 (546)	44 (1118)	22 (559)	1 (25)	5-7/16 (138)	25-5/8 (651)	29-1/2 (749)	6 (152)	6 (152)	9 (229)
364T	24 (610)	56 (1422)	59-1/2 (1511)	16-1/2 (419)	21-1/2 (546)	44 (1118)	22 (559)	1 (25)	5-7/16 (138)	26-3/4 (679)	29-1/2 (749)	6 (152)	6 (152)	9 (229)
365T	24 (610)	56 (1422)	60-1/2 (1537)	16-1/2 (419)	21-1/2 (546)	44 (1118)	22 (559)	1 (25)	5-7/16 (138)	26-3/4 (679)	29-1/2 (749)	6 (152)	6 (152)	9 (229)

Dimensions are subject to change. Not to be used for construction purposes unless certified.

Xylem Inc.
8200 N. Austin Avenue
Morton Grove, IL 60053
Phone: (847)966-3700
Fax: (847)965-8379
www.gouldswatertechnology.com

