

<b>JOB:</b>	<b>REPRESENTATIVE:</b>	
<b>UNIT TAG:</b>	<b>ORDER NO.:</b>	<b>DATE:</b>
<b>ENGINEER:</b>	<b>SUBMITTED BY:</b>	<b>DATE:</b>
<b>CONTRACTOR:</b>	<b>APPROVED BY:</b>	<b>DATE:</b>

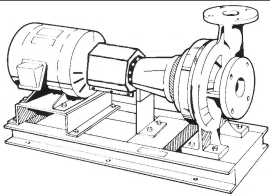

## 2.5-7C

# Marlow Series e-530SL

### Centrifugal Pumps - Base Mounted

**SPECIFICATIONS**

FLOW \_\_\_\_\_ HEAD \_\_\_\_\_  
 HP \_\_\_\_\_ RPM \_\_\_\_\_  
 VOLTS \_\_\_\_\_  
 CYCLE \_\_\_\_\_ PHASE \_\_\_\_\_  
 ENCLOSURE \_\_\_\_\_  
 APPROX. WEIGHT \_\_\_\_\_  
 SPECIALS \_\_\_\_\_

**MATERIALS OF CONSTRUCTION**

Stainless Steel Fitted

**FEATURES**

- ANSI/OSHA Coupling Guard
- Center Drop Out Spacer Coupling
- Fabricated Heavy Duty Baseplate

**MAXIMUM WORKING PRESSURE**

175 psi (12 bar) W.P.  
 w/ 125# ANSI flange drilling

**TYPE OF SEAL**

- Standard Seal (Buna-Carbon/Ceramic)
- F Standard Seal w/ Flush Line (Buna-Carbon/Ceramic)
- S Stuffing Box Construction w/ Flushed Mechanical Single Seal (EPR-Tungsten Carbide/Carbon)
- PF Stuffing Box Construction w/ Packing (Graphite Impregnated Teflon)

**Note: Equipped with NEOPRENE coupling**

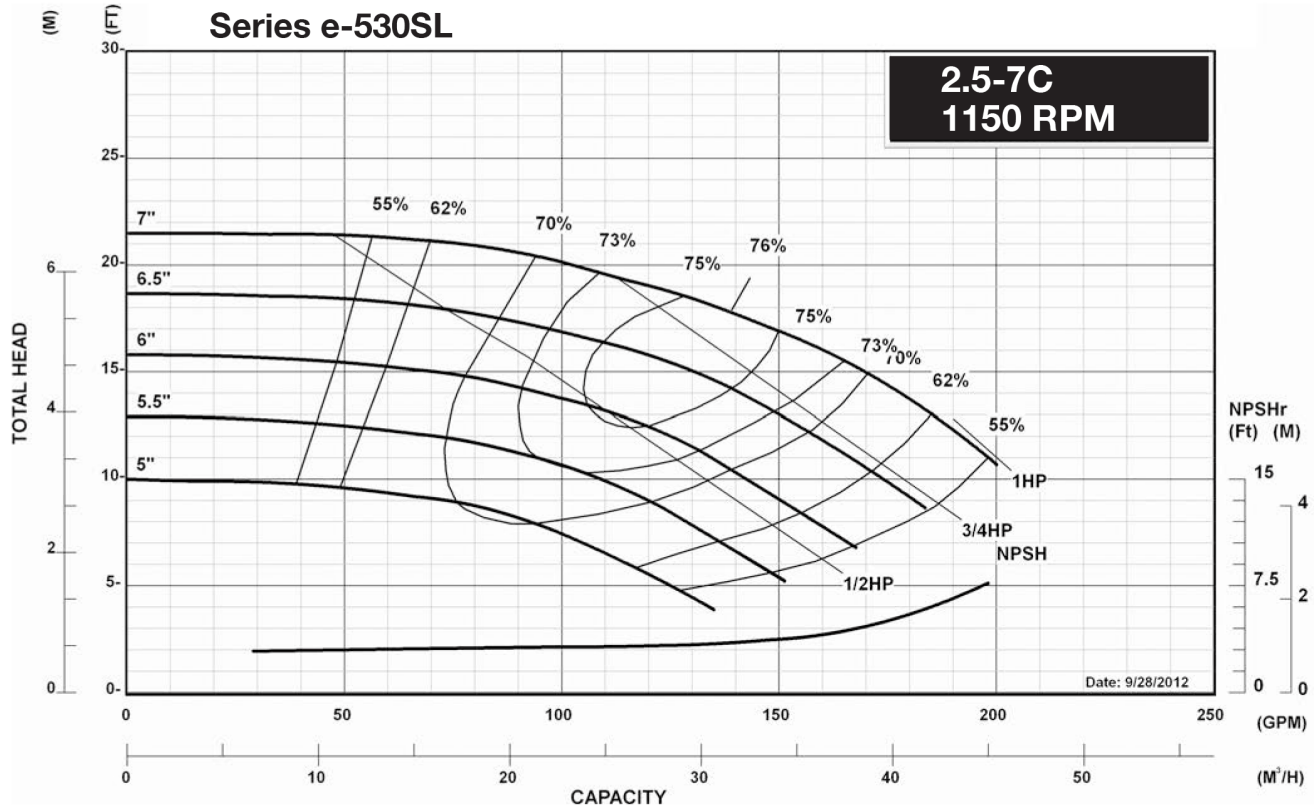

<b>JOB:</b>	<b>REPRESENTATIVE:</b>	
<b>UNIT TAG:</b>	<b>ORDER NO.:</b>	<b>DATE:</b>
<b>ENGINEER:</b>	<b>SUBMITTED BY:</b>	<b>DATE:</b>
<b>CONTRACTOR:</b>	<b>APPROVED BY:</b>	<b>DATE:</b>

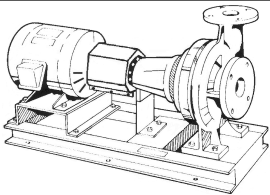

## 2.5-7C

# Marlow Series e-530SL

### Centrifugal Pumps - Base Mounted

**SPECIFICATIONS**

FLOW \_\_\_\_\_ HEAD \_\_\_\_\_  
 HP \_\_\_\_\_ RPM \_\_\_\_\_  
 VOLTS \_\_\_\_\_  
 CYCLE \_\_\_\_\_ PHASE \_\_\_\_\_  
 ENCLOSURE \_\_\_\_\_  
 APPROX. WEIGHT \_\_\_\_\_  
 SPECIALS \_\_\_\_\_

**MATERIALS OF CONSTRUCTION**

Stainless Steel Fitted

**FEATURES**

- ANSI/OSHA Coupling Guard
- Center Drop Out Spacer Coupling
- Fabricated Heavy Duty Baseplate

**MAXIMUM WORKING PRESSURE**

175 psi (12 bar) W.P.  
 w/ 125# ANSI flange drilling

**TYPE OF SEAL**

- Standard Seal (Buna-Carbon/Ceramic)
- F Standard Seal w/ Flush Line (Buna-Carbon/Ceramic)
- S Stuffing Box Construction w/ Flushed Mechanical Single Seal (EPR-Tungsten Carbide/Carbon)
- PF Stuffing Box Construction w/ Packing (Graphite Impregnated Teflon)

**Note: Equipped with NEOPRENE coupling**

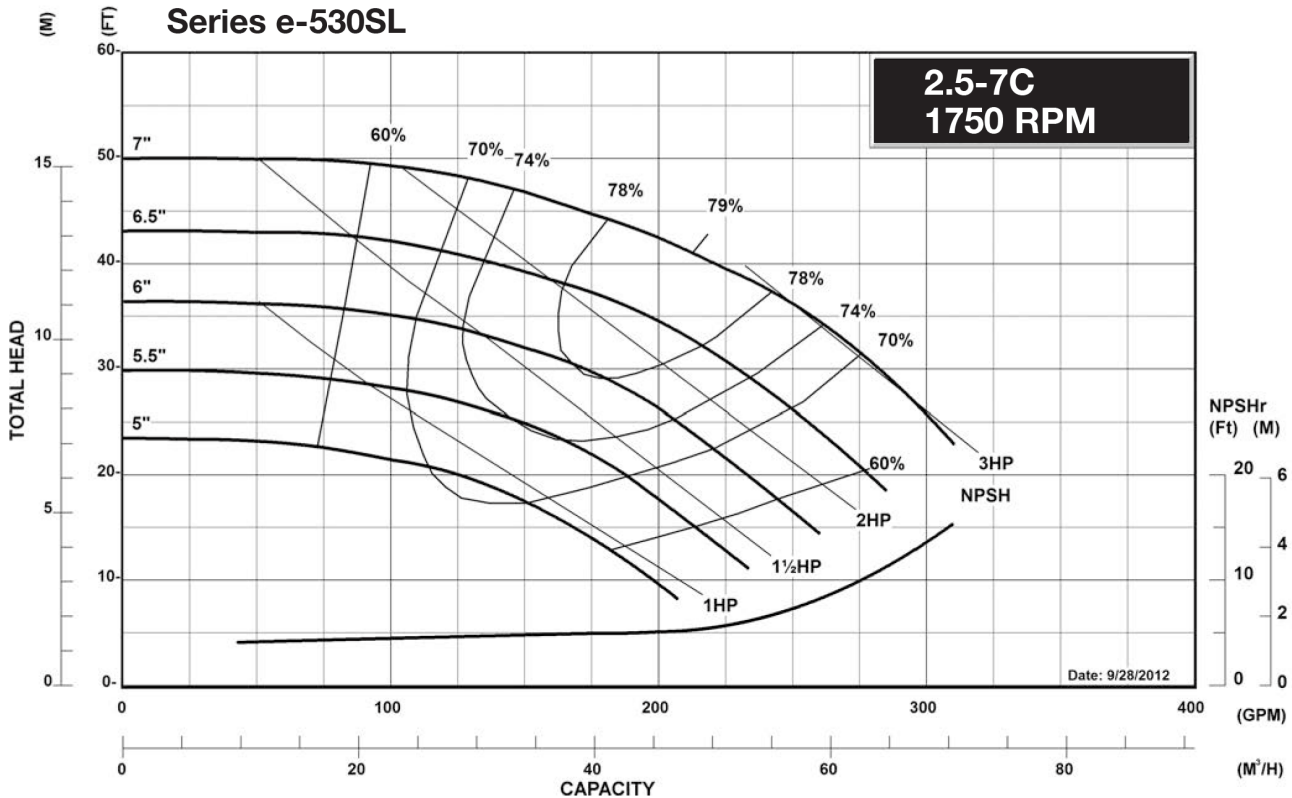

<b>JOB:</b>	<b>REPRESENTATIVE:</b>	
<b>UNIT TAG:</b>	<b>ORDER NO.:</b>	<b>DATE:</b>
<b>ENGINEER:</b>	<b>SUBMITTED BY:</b>	<b>DATE:</b>
<b>CONTRACTOR:</b>	<b>APPROVED BY:</b>	<b>DATE:</b>

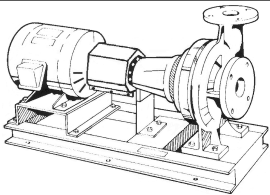

## 2.5-7C

# Marlow Series e-530SL

### Centrifugal Pumps - Base Mounted

**SPECIFICATIONS**

FLOW \_\_\_\_\_ HEAD \_\_\_\_\_  
 HP \_\_\_\_\_ RPM \_\_\_\_\_  
 VOLTS \_\_\_\_\_  
 CYCLE \_\_\_\_\_ PHASE \_\_\_\_\_  
 ENCLOSURE \_\_\_\_\_  
 APPROX. WEIGHT \_\_\_\_\_  
 SPECIALS \_\_\_\_\_

**MATERIALS OF CONSTRUCTION**

Stainless Steel Fitted

**FEATURES**

- ANSI/OSHA Coupling Guard
- Center Drop Out Spacer Coupling
- Fabricated Heavy Duty Baseplate

**MAXIMUM WORKING PRESSURE**

175 psi (12 bar) W.P.  
w/ 125# ANSI flange drilling

**TYPE OF SEAL**

- Standard Seal (Buna-Carbon/Ceramic)
- F Standard Seal w/ Flush Line (Buna-Carbon/Ceramic)
- S Stuffing Box Construction w/ Flushed Mechanical Single Seal (EPR-Tungsten Carbide/Carbon)
- PF Stuffing Box Construction w/ Packing (Graphite Impregnated Teflon)

**Note:** Equipped with NEOPRENE coupling

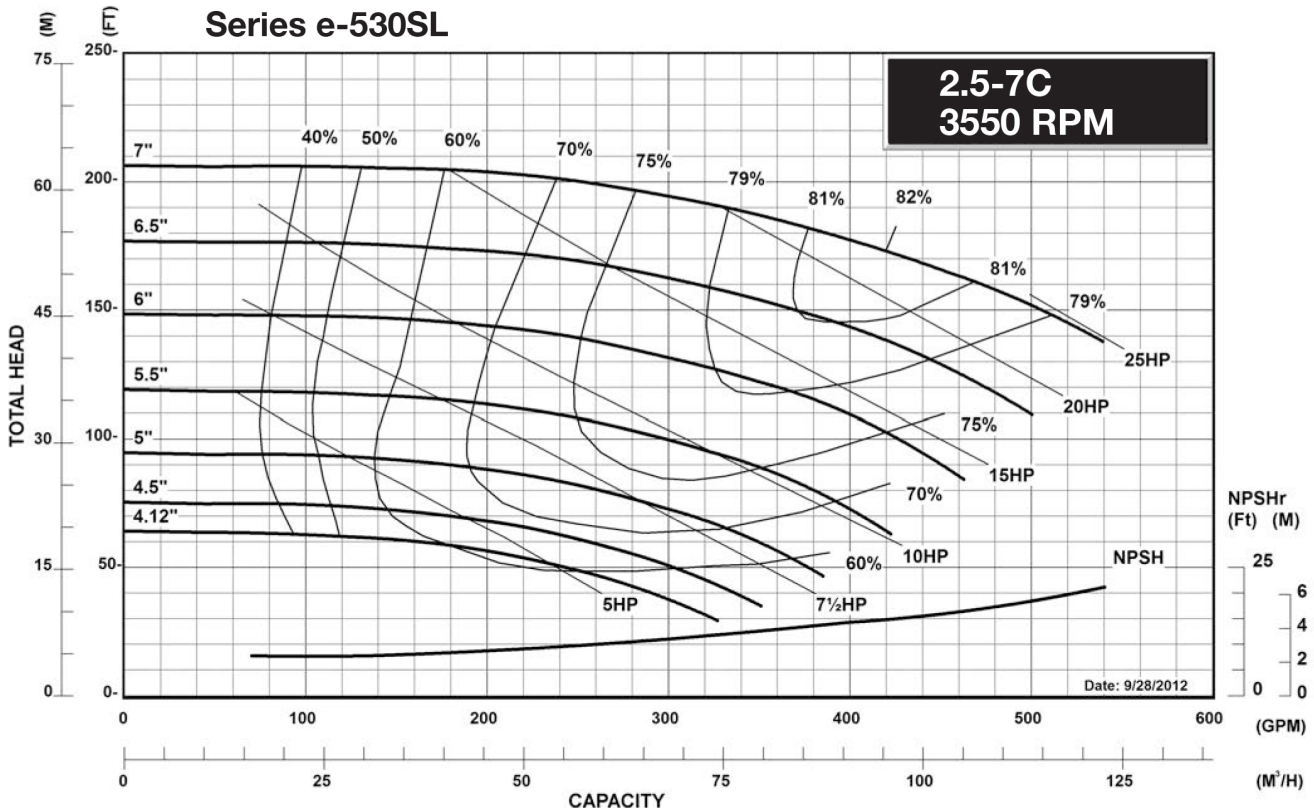

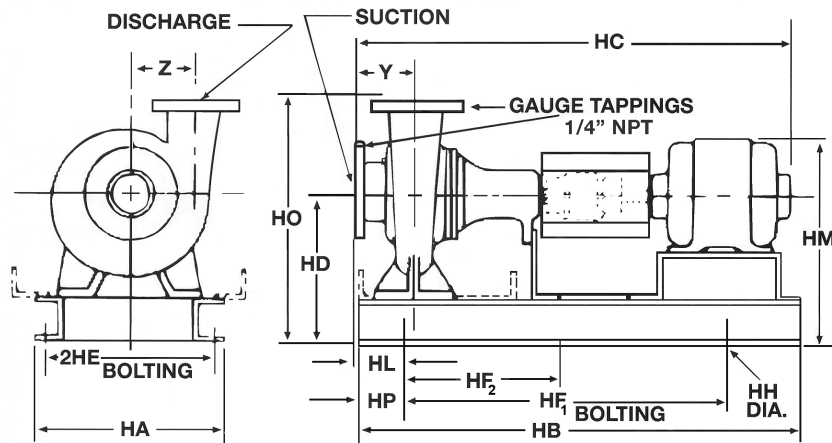

FLANGE DIMENSIONS IN INCHES (MM)			
	SIZE	THICKNESS	O.D.
Discharge	2-1/2" (64)	11/16 (17)	7 (178)
Suction	3" (76)	3/4 (19)	7.5 (191)

FLANGES ARE 125# ANSI - STANDARD

DIMENSIONS - Inches (mm)

STANDARD SEAL

MOTOR FRAME	HA	HB	HC MAX	HD	2HE	HF <sub>1</sub>	HF <sub>2</sub>	HH	HL	HM MAX	HO	HP	Y	Z
56	12 (305)	28-3/4 (730)	29-5/8 (752)	9-3/4 (248)	10-1/4 (260)	22-1/2 (572)	-	3/4 (19)	4-3/8 (111)	13-3/8 (340)	15-3/4 (400)	3 (77)	4-1/4 (108)	4-11/16 (119)
143T	12 (305)	28-3/4 (730)	29-3/4 (756)	9-3/4 (248)	10-1/4 (260)	22-1/2 (572)	-	3/4 (19)	4-3/8 (111)	13-1/2 (343)	15-3/4 (400)	3 (77)	4-1/4 (108)	4-11/16 (119)
145T	12 (305)	28-3/4 (730)	30-3/4 (781)	9-3/4 (248)	10-1/4 (260)	22-1/2 (572)	-	3/4 (19)	4-3/8 (111)	13-1/2 (343)	15-3/4 (400)	3 (77)	4-1/4 (108)	4-11/16 (119)
182T	14-5/8 (305)	31 (787)	33-1/2 (851)	9-3/4 (248)	12-7/8 (327)	25 (635)	-	3/4 (19)	3 (77)	15 (381)	15-3/4 (400)	3 (77)	4-1/4 (108)	4-11/16 (119)
184T	14-5/8 (305)	31 (787)	34-1/4 (870)	9-3/4 (248)	12-7/8 (327)	25 (635)	-	3/4 (19)	3 (77)	15 (381)	15-3/4 (400)	3 (77)	4-1/4 (108)	4-11/16 (119)
213T	14-5/8 (305)	34-5/8 (879)	36-3/4 (933)	9-3/4 (248)	12-7/8 (327)	28-5/8 (727)	-	3/4 (19)	3 (77)	15-5/8 (397)	15-3/4 (400)	3 (77)	4-1/4 (108)	4-11/16 (119)
215T	14-5/8 (305)	34-5/8 (879)	38-1/4 (972)	9-3/4 (248)	12-7/8 (327)	28-5/8 (727)	-	3/4 (19)	3 (77)	15-5/8 (397)	15-3/4 (400)	3 (77)	4-1/4 (108)	4-11/16 (119)
254T	14-5/8 (305)	39-3/8 (1000)	42 (1067)	10-3/4 (273)	12-7/8 (327)	33-3/8 (848)	-	3/4 (19)	3 (77)	17-5/8 (448)	16-3/4 (425)	3 (77)	4-1/4 (108)	4-11/16 (119)
256T	14-5/8 (305)	39-3/8 (1000)	43-3/4 (1111)	10-3/4 (273)	12-7/8 (327)	33-3/8 (848)	-	3/4 (19)	3 (77)	17-5/8 (448)	16-3/4 (425)	3 (77)	4-1/4 (108)	4-11/16 (119)
284TS	16 (406)	46-1/2 (1181)	44.25 (1124)	13 (330)	14 (356)	36-1/2 (927)	18-1/4 (464)	7/8 (22)	4-1/8 (105)	21 (533)	19 (483)	5 (127)	4-1/4 (108)	4-11/16 (119)

STUFFING BOX

MOTOR FRAME	HA	HB	HC MAX	HD	2HE	HF <sub>1</sub>	HF <sub>2</sub>	HH	HL	HM MAX	HO	HP	Y	Z
56	14-5/8 (305)	34-5/8 (879)	33-1/4 (845)	9-3/4 (248)	12-7/8 (327)	28-5/8 (727)	-	3/4 (19)	3 (77)	13-3/8 (340)	15-3/4 (400)	3 (77)	4-1/4 (108)	4-11/16 (119)
143T	14-5/8 (371)	34-5/8 (879)	33-3/8 (848)	9-3/4 (248)	12-7/8 (327)	28-5/8 (727)	-	3/4 (19)	3 (77)	13-3/8 (340)	15-3/4 (400)	3 (77)	4-1/4 (108)	4-11/16 (119)
145T	14-5/8 (371)	34-5/8 (879)	34-3/8 (873)	9-3/4 (248)	12-7/8 (327)	28-5/8 (727)	-	3/4 (19)	3 (77)	13-1/2 (343)	15-3/4 (400)	3 (77)	4-1/4 (108)	4-11/16 (119)
182T	14-5/8 (371)	34-5/8 (879)	37-1/8 (943)	9-3/4 (248)	12-7/8 (327)	28-5/8 (727)	-	3/4 (19)	3 (77)	13-1/2 (343)	15-3/4 (400)	3 (77)	4-1/4 (108)	4-11/16 (119)
184T	14-5/8 (371)	34-5/8 (879)	37-1/8 (943)	9-3/4 (248)	12-7/8 (327)	28-5/8 (727)	-	3/4 (19)	3 (77)	15 (381)	15-3/4 (400)	3 (77)	4-1/4 (108)	4-11/16 (119)
<b>"L" FRAME</b>														
213T	16 (406)	46-1/2 (1181)	43-3/4 (1105)	11 (279)	14 (356)	36-1/2 (927)	18-1/4 (464)	7/8 (22)	4-1/8 (105)	16-7/8 (429)	17 (432)	5 (127)	4-1/4 (108)	4-11/16 (119)
215T	16 (406)	46-1/2 (1181)	45 (1143)	11 (279)	14 (356)	36-1/2 (927)	18-1/4 (464)	7/8 (22)	4-1/8 (105)	16-7/8 (429)	17 (432)	5 (127)	4-1/4 (108)	4-11/16 (119)
254T	16 (406)	51-3/4 (1314)	48-3/4 (1238)	12 (305)	14 (356)	41-3/4 (1060)	20-7/8 (530)	7/8 (22)	4-1/8 (105)	18-7/8 (479)	18 (457)	5 (127)	4-1/4 (108)	4-11/16 (119)
256T	16 (406)	51-3/4 (1314)	50-1/2 (1283)	12 (305)	14 (356)	41-3/4 (1060)	20-7/8 (530)	7/8 (22)	4-1/8 (105)	18-7/8 (479)	18 (457)	5 (127)	4-1/4 (108)	4-11/16 (119)

Dimensions are subject to change. Not to be used for construction purposes unless certified.

Xylem Inc.  
 8200 N. Austin Avenue  
 Morton Grove, IL 60053  
 Phone: (847)966-3700  
 Fax: (847)965-8379  
 www.gouldswatertechology.com

