

JOB:	REPRESENTATIVE:	
UNIT TAG:	ORDER NO.	DATE:
ENGINEER:	SUBMITTED BY:	DATE:
CONTRACTOR:	APPROVED BY:	DATE:

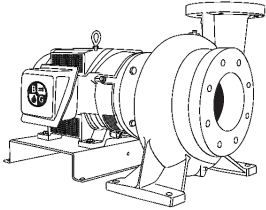

2.5-9B

Marlow Series e-531SC

Close-Coupled Centrifugal Pumps

SPECIFICATIONS

FLOW _____ HEAD _____

HP _____ RPM _____

VOLTS _____

CYCLE _____ PHASE _____

ENCLOSURE _____

APPROX. WEIGHT _____

SPECIALS _____

MATERIALS OF CONSTRUCTION

Stainless Steel Fitted

MAXIMUM WORKING PRESSURE

175 psi (12 bar) W.P.
with 125# ANSI flange drilling

TYPE OF SEAL

- Standard Seal (Buna-Carbon/Ceramic)
- F Standard Seal w/ Flush Line (Buna-Carbon/Ceramic)
- S Stuffing Box Construction w/ Flushed Mechanical Single Seal (EPR-Tungsten Carbide/Carbon)
- PF Stuffing Box Construction w/ Flushed Packing (Graphite Impregnated Teflon)

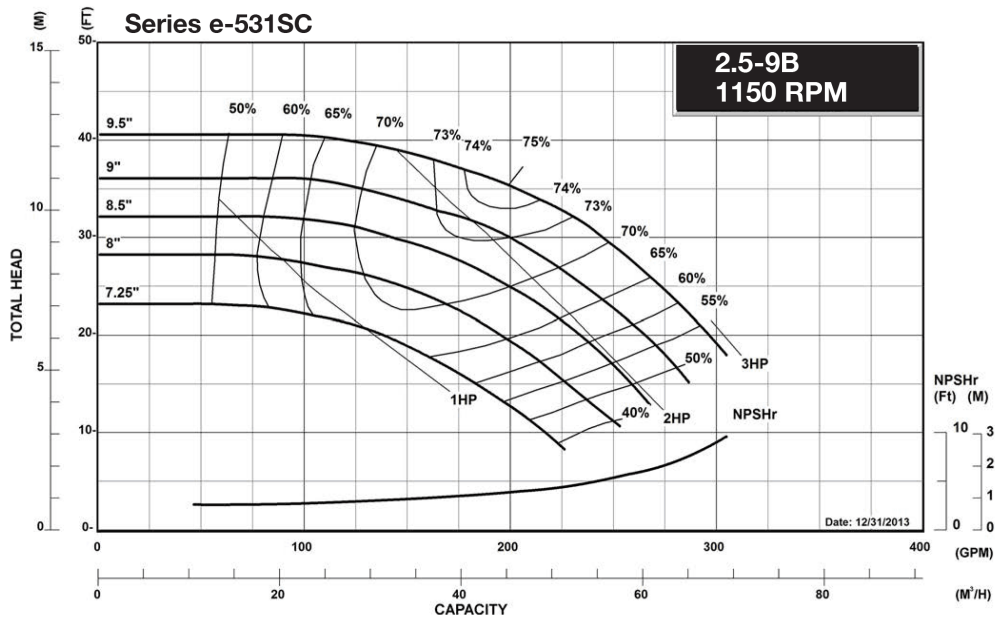

JOB: UNIT TAG: ENGINEER: CONTRACTOR:	REPRESENTATIVE: ORDER NO.: SUBMITTED BY: APPROVED BY:	DATE: DATE: DATE:
---	--	--

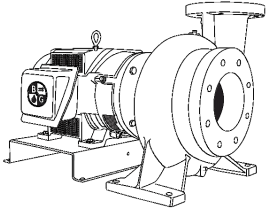

2.5-9B

Marlow Series e-531SC

Close-Coupled Centrifugal Pumps

SPECIFICATIONS

FLOW _____ HEAD _____
 HP _____ RPM _____
 VOLTS _____
 CYCLE _____ PHASE _____
 ENCLOSURE _____
 APPROX. WEIGHT _____
 SPECIALS _____

MATERIALS OF CONSTRUCTION

Stainless Steel Fitted

MAXIMUM WORKING PRESSURE

175 psi (12 bar) W.P.
with 125# ANSI flange drilling

TYPE OF SEAL

- Standard Seal (Buna-Carbon/Ceramic)
- F Standard Seal w/ Flush Line (Buna-Carbon/Ceramic)
- S Stuffing Box Construction w/ Flushed Mechanical Single Seal (EPR-Tungsten Carbide/Carbon)
- PF Stuffing Box Construction w/ Flushed Packing (Graphite Impregnated Teflon)

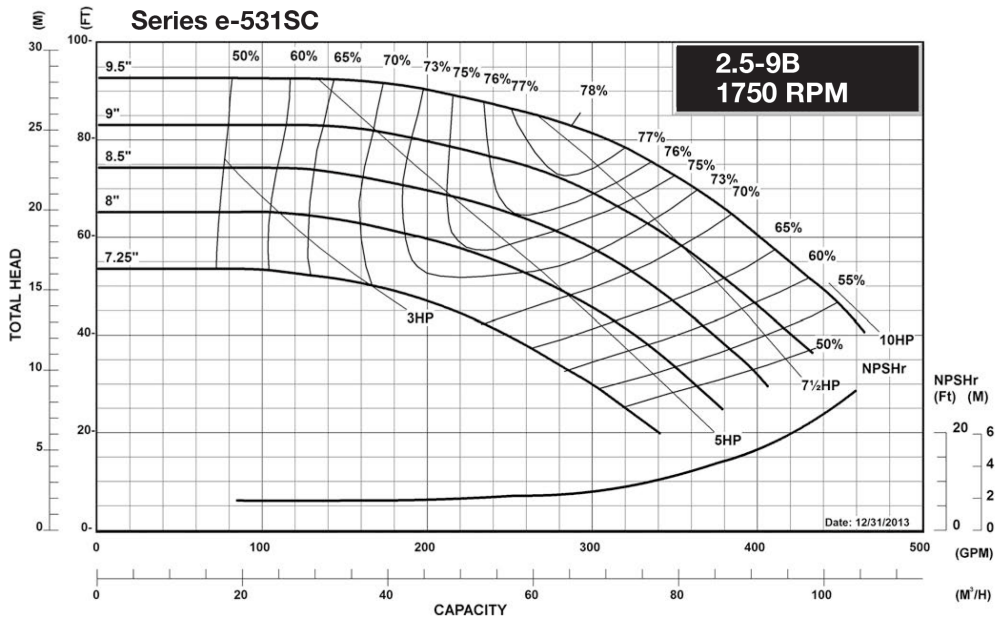

JOB:	REPRESENTATIVE:	
UNIT TAG:	ORDER NO.	DATE:
ENGINEER:	SUBMITTED BY:	DATE:
CONTRACTOR:	APPROVED BY:	DATE:

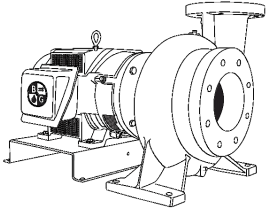

2.5-9B

Marlow Series e-531SC

Close-Coupled Centrifugal Pumps

SPECIFICATIONS

FLOW _____ HEAD _____

HP _____ RPM _____

VOLTS _____

CYCLE _____ PHASE _____

ENCLOSURE _____

APPROX. WEIGHT _____

SPECIALS _____

MATERIALS OF CONSTRUCTION

Stainless Steel Fitted

MAXIMUM WORKING PRESSURE

175 psi (12 bar) W.P.
with 125# ANSI flange drilling

TYPE OF SEAL

- Standard Seal (Buna-Carbon/Ceramic)
- F Standard Seal w/ Flush Line (Buna-Carbon/Ceramic)
- S Stuffing Box Construction w/ Flushed Mechanical Single Seal (EPR-Tungsten Carbide/Carbon)
- PF Stuffing Box Construction w/ Flushed Packing (Graphite Impregnated Teflon)

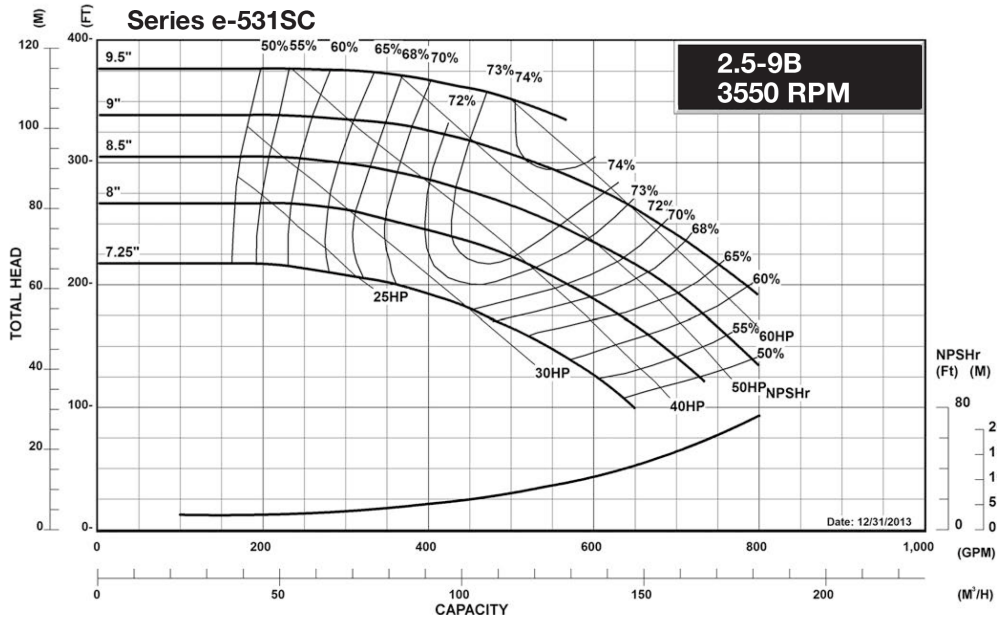

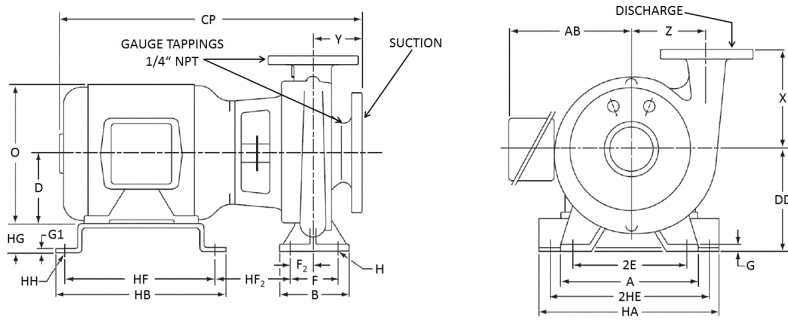

PUMP DIMENSIONS - INCHES (MM)						
X		Y		Z		
6.75 (171)		4.00 (102)		6.00 (152)		

FLANGE DIMENSIONS - INCHES (MM)						
125# ANSI FLAT FACE	NOMINAL PIPE SIZE	O.D.	THICKNESS	BOLT CIRCLE DIAMETER	NO. OF BOLTS	SIZE OF BOLTS
DISCHARGE	2.50	7.00 (178)	0.69 (17)	5.50 (140)	4	0.63 (14)
SUCTION	3.00	7.63 (194)	0.75 (19)	6.00 (152)	4	0.63 (14)

DIMENSIONS - INCHES (mm)

STANDARD SEAL

MOTOR FRAME	A	AB	HB	CP MAX	D	HF	G	G1	H	HH	HA	F2	2E	2HE	HF2 MAX	B	F	O	HG	DD
182JM	11.00 (279)	8.50 (216)	10.50 (267)	22.88 (581)	4.50 (114)	9.25 (235)	0.69 (17)	0.19 (5)	0.63 (16)	0.50 (13)	13.63 (346)	1.61 (41)	9.13 (232)	12.50 (318)	4.96 (126)	6.00 (152)	4.38 (111)	9.75 (248)	3.50 (89)	8.00 (203)
184JM	11.00 (279)	8.50 (216)	10.50 (267)	22.88 (581)	4.50 (114)	9.25 (235)	0.69 (17)	0.19 (5)	0.63 (16)	0.50 (13)	13.63 (346)	1.61 (41)	9.13 (232)	12.50 (318)	4.96 (126)	6.00 (152)	4.38 (111)	9.75 (248)	3.50 (89)	8.00 (203)
213JM	11.00 (279)	10.75 (273)	12.00 (305)	25.00 (635)	5.25 (133)	10.75 (273)	0.69 (17)	0.19 (5)	0.63 (16)	0.50 (13)	13.63 (346)	1.61 (41)	9.13 (232)	12.50 (318)	5.83 (148)	6.00 (152)	4.38 (111)	11.13 (283)	2.75 (70)	8.00 (203)
215JM	11.00 (279)	10.75 (273)	12.00 (305)	26.50 (673)	5.25 (133)	10.75 (273)	0.69 (17)	0.19 (5)	0.63 (16)	0.50 (13)	13.63 (346)	1.61 (41)	9.13 (232)	12.50 (318)	5.83 (148)	6.00 (152)	4.38 (111)	11.13 (283)	2.75 (70)	8.00 (203)
254JM	11.00 (279)	10.75 (273)	15.50 (394)	30.38 (772)	6.25 (159)	14.25 (362)	0.69 (17)	0.19 (5)	0.63 (16)	0.50 (13)	13.63 (346)	1.61 (41)	9.13 (232)	12.50 (318)	7.08 (180)	6.00 (152)	4.38 (111)	13.13 (333)	1.75 (44)	8.00 (203)
256JM	11.00 (279)	10.75 (273)	15.50 (394)	32.13 (816)	6.25 (159)	14.25 (362)	0.69 (17)	0.19 (5)	0.63 (16)	0.50 (13)	13.63 (346)	1.61 (41)	9.13 (232)	12.50 (318)	7.08 (180)	6.00 (152)	4.38 (111)	13.13 (333)	1.75 (44)	8.00 (203)
284JM	11.00 (279)	12.63 (321)	17.00 (432)	31.75 (806)	7.00 (178)	15.50 (394)	0.69 (17)	0.25 (6)	0.63 (16)	0.63 (16)	14.00 (356)	1.61 (41)	9.13 (232)	12.50 (318)	6.95 (177)	6.00 (152)	4.38 (111)	15.00 (381)	2.00 (51)	9.00 (229)
286JM	11.00 (279)	12.63 (321)	17.00 (432)	33.25 (845)	7.00 (178)	15.50 (394)	0.69 (17)	0.25 (6)	0.63 (16)	0.63 (16)	14.00 (356)	1.61 (41)	9.13 (232)	12.50 (318)	6.95 (177)	6.00 (152)	4.38 (111)	15.00 (381)	2.00 (51)	9.00 (229)
324JM	11.00 (279)	15.13 (384)	14.00 (356)	34.75 (883)	8.00 (203)	10.50 (267)	0.69 (17)	0.75 (19)	0.63 (16)	0.66 (17)	16.00 (406)	1.61 (41)	9.13 (232)	12.50 (318)	9.70 (240)	6.00 (152)	4.38 (111)	17.13 (435)	0.00 (0)	8.00 (203)
326JM	11.00 (279)	15.13 (384)	15.50 (394)	36.25 (921)	8.00 (203)	12.00 (305)	0.69 (17)	0.75 (19)	0.63 (16)	0.66 (17)	16.00 (406)	1.61 (41)	9.13 (232)	12.50 (318)	9.70 (246)	6.00 (152)	4.38 (111)	17.13 (435)	0.00 (0)	8.00 (203)

DIMENSIONS - INCHES (mm)

STUFFING BOX

MOTOR FRAME	A	AB	HB	CP MAX	D	HF	G	G1	H	HH	HA	F2	2E	2HE	HF2 MAX	B	F	O	HG	DD
182JP	11.00 (279)	8.50 (216)	10.50 (267)	26.00 (660)	4.50 (114)	9.25 (235)	0.69 (17)	0.19 (5)	0.63 (16)	0.50 (13)	13.63 (346)	1.61 (41)	9.13 (232)	12.50 (318)	8.08 (205)	6.00 (152)	4.38 (111)	9.75 (248)	3.50 (89)	8.00 (203)
184JP	11.00 (279)	8.50 (216)	10.50 (267)	26.00 (660)	4.50 (114)	9.25 (235)	0.69 (17)	0.19 (5)	0.63 (16)	0.50 (13)	13.63 (346)	1.61 (41)	9.13 (232)	12.50 (318)	8.08 (205)	6.00 (152)	4.38 (111)	9.75 (248)	3.50 (89)	8.00 (203)
213JP	11.00 (279)	10.75 (273)	12.00 (305)	28.88 (733)	5.25 (133)	10.75 (273)	0.69 (17)	0.19 (5)	0.63 (16)	0.50 (13)	13.63 (346)	1.61 (41)	9.13 (232)	12.50 (318)	9.70 (246)	6.00 (152)	4.38 (111)	11.13 (283)	2.75 (70)	8.00 (203)
215JP	11.00 (279)	10.75 (273)	12.00 (305)	30.38 (772)	5.25 (133)	10.75 (273)	0.69 (17)	0.19 (5)	0.63 (16)	0.50 (13)	13.63 (346)	1.61 (41)	9.13 (232)	12.50 (318)	9.70 (246)	6.00 (152)	4.38 (111)	11.13 (283)	2.75 (70)	8.00 (203)
254JP	11.00 (279)	10.75 (273)	15.50 (394)	33.25 (845)	6.25 (159)	14.25 (362)	0.69 (17)	0.19 (5)	0.63 (16)	0.50 (13)	13.63 (346)	1.61 (41)	9.13 (232)	12.50 (318)	9.95 (253)	6.00 (152)	4.38 (111)	13.13 (333)	1.75 (44)	8.00 (203)
256JP	11.00 (279)	10.75 (273)	15.50 (394)	35.00 (889)	6.25 (159)	14.25 (362)	0.69 (17)	0.19 (5)	0.63 (16)	0.50 (13)	13.63 (346)	1.61 (41)	9.13 (232)	12.50 (318)	9.95 (253)	6.00 (152)	4.38 (111)	13.13 (333)	1.75 (44)	8.00 (203)
284JP	11.00 (279)	12.63 (321)	17.00 (432)	34.63 (879)	7.00 (178)	15.50 (394)	0.69 (17)	0.25 (6)	0.63 (16)	0.63 (16)	14.00 (356)	1.61 (41)	9.13 (232)	12.50 (318)	9.83 (250)	6.00 (152)	4.38 (111)	15.00 (381)	2.00 (51)	9.00 (229)
286JP	11.00 (279)	12.63 (321)	17.00 (432)	36.13 (918)	7.00 (178)	15.50 (394)	0.69 (17)	0.25 (6)	0.63 (16)	0.63 (16)	14.00 (356)	1.61 (41)	9.13 (232)	12.50 (318)	9.83 (250)	6.00 (152)	4.38 (111)	15.00 (381)	2.00 (51)	9.00 (229)
324JP	11.00 (279)	15.13 (384)	14.00 (356)	37.63 (956)	8.00 (203)	10.50 (267)	0.69 (17)	0.75 (19)	0.63 (16)	0.66 (17)	16.00 (406)	1.61 (41)	9.13 (232)	12.50 (318)	12.58 (320)	6.00 (152)	4.38 (111)	17.13 (435)	0.00 (0)	8.00 (203)
326JP	11.00 (279)	15.13 (384)	15.50 (394)	39.13 (994)	8.00 (203)	12.00 (305)	0.69 (17)	0.75 (19)	0.63 (16)	0.66 (17)	16.00 (406)	1.61 (41)	9.13 (232)	12.50 (318)	12.58 (320)	6.00 (152)	4.38 (111)	17.13 (435)	0.00 (0)	8.00 (203)

Dimensions are subject to change. Not to be used for construction purposes unless certified.

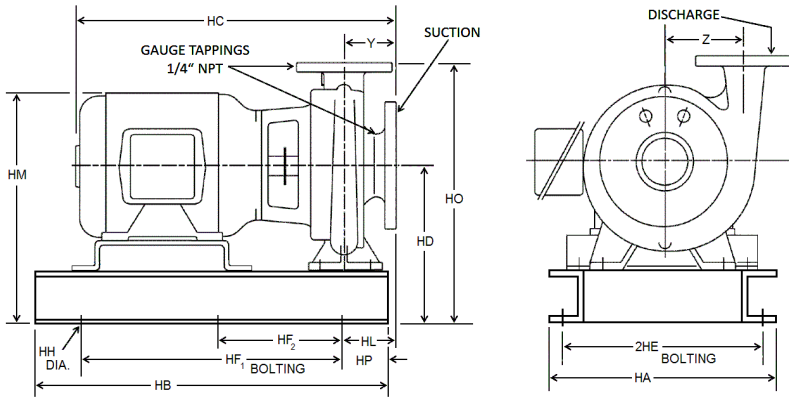

PUMP DIMENSIONS - INCHES (MM)	
Y	Z
4.00 (102)	6.00 (152)

FLANGE DIMENSIONS - INCHES (MM)						
125# ANSI FLAT FACE	NOMINAL PIPE SIZE	O.D.	THICKNESS	BOLT CIRCLE DIAMETER	NO. OF BOLTS	SIZE OF BOLTS
DISCHARGE	2.5	7.00 (178)	0.69 (17)	5.50 (140)	4	0.63 (14)
SUCTION	3	7.63 (194)	0.75 (19)	6.00 (152)	4	0.63 (14)

DIMENSIONS - INCHES (mm)

STANDARD SEAL

MOTOR FRAME	HA	HB	HC MAX	HD	2HE	HF1	HF2	HH	HL	HM MAX	HO	HP
182JM	14.63 (371)	31.00 (787)	22.88 (581)	10.75 (273)	12.88 (327)	25.00 (635)	-	0.75 (19)	2.75 (70)	16.00 (406)	17.50 (445)	3.00 (76)
184JM	14.63 (371)	31.00 (787)	22.88 (581)	10.75 (273)	12.88 (327)	25.00 (635)	-	0.75 (19)	2.75 (70)	16.00 (406)	17.50 (445)	3.00 (76)
213JM	14.63 (371)	31.00 (787)	25.00 (635)	10.75 (273)	12.88 (327)	25.00 (635)	-	0.75 (19)	2.75 (70)	16.63 (422)	17.50 (445)	3.00 (76)
215JM	14.63 (371)	31.00 (787)	26.50 (673)	10.75 (273)	12.88 (327)	25.00 (635)	-	0.75 (19)	2.75 (70)	16.63 (422)	17.50 (445)	3.00 (76)
254JM	16.00 (406)	46.50 (1181)	30.38 (772)	12.00 (305)	14.00 (356)	36.50 (927)	18.25 (464)	0.88 (22)	3.88 (98)	18.88 (479)	18.75 (476)	5.00 (127)
256JM	16.00 (406)	46.50 (1181)	32.13 (816)	12.00 (305)	14.00 (356)	36.50 (927)	18.25 (464)	0.88 (22)	3.88 (98)	18.88 (479)	18.75 (476)	5.00 (127)
284JM	16.00 (406)	46.50 (1181)	31.75 (806)	13.00 (330)	14.00 (356)	36.50 (927)	18.25 (464)	0.88 (22)	3.88 (98)	21.00 (533)	19.75 (502)	5.00 (127)
286JM	16.00 (406)	46.50 (1181)	33.25 (845)	13.00 (330)	14.00 (356)	36.50 (927)	18.25 (464)	0.88 (22)	3.88 (98)	21.00 (533)	19.75 (502)	5.00 (127)
324JM	16.00 (406)	46.50 (1181)	34.75 (883)	12.00 (305)	14.00 (356)	36.50 (927)	18.25 (464)	0.88 (22)	3.88 (98)	21.00 (533)	18.75 (476)	5.00 (127)
326JM	16.00 (406)	46.50 (1181)	36.25 (921)	12.00 (305)	14.00 (356)	36.50 (927)	18.25 (464)	0.88 (22)	3.88 (98)	21.00 (533)	18.75 (476)	5.00 (127)

DIMENSIONS - INCHES (mm)

STUFFING BOX

MOTOR FRAME	HA	HB	HC MAX	HD	2HE	HF1	HF2	HH	HL	HM MAX	HO	HP
182JP	14.63 (371)	31.00 (787)	26.00 (660)	10.75 (273)	12.88 (327)	25.00 (635)	-	0.75 (19)	2.75 (70)	16.00 (406)	17.50 (445)	3.00 (76)
184JP	14.63 (371)	31.00 (787)	26.00 (660)	10.75 (273)	12.88 (327)	25.00 (635)	-	0.75 (19)	2.75 (70)	16.00 (406)	17.50 (445)	3.00 (76)
213JP	14.63 (371)	31.00 (787)	28.88 (733)	10.75 (273)	12.88 (327)	25.00 (635)	-	0.75 (19)	2.75 (70)	16.63 (422)	17.50 (445)	3.00 (76)
215JP	14.63 (371)	31.00 (787)	30.38 (772)	10.75 (273)	12.88 (327)	25.00 (635)	-	0.75 (19)	2.75 (70)	16.63 (422)	17.50 (445)	3.00 (76)
254JP	16.00 (406)	46.50 (1181)	33.25 (845)	12.00 (305)	14.00 (356)	36.50 (927)	18.25 (464)	0.88 (22)	3.88 (98)	18.88 (479)	18.75 (476)	5.00 (127)
256JP	16.00 (406)	46.50 (1181)	35.00 (889)	12.00 (305)	14.00 (356)	36.50 (927)	18.25 (464)	0.88 (22)	3.88 (98)	18.88 (479)	18.75 (476)	5.00 (127)
284JP	16.00 (406)	46.50 (1181)	34.63 (879)	13.00 (330)	14.00 (356)	36.50 (927)	18.25 (464)	0.88 (22)	3.88 (98)	21.00 (533)	19.75 (502)	5.00 (127)
286JP	16.00 (406)	46.50 (1181)	36.13 (918)	13.00 (330)	14.00 (356)	36.50 (927)	18.25 (464)	0.88 (22)	3.88 (98)	21.00 (533)	19.75 (502)	5.00 (127)
324JP	16.00 (406)	46.50 (1181)	37.63 (956)	12.00 (305)	14.00 (356)	36.50 (927)	18.25 (464)	0.88 (22)	3.88 (98)	21.00 (533)	18.75 (476)	5.00 (127)
326JP	16.00 (406)	46.50 (1181)	39.13 (994)	12.00 (305)	14.00 (356)	36.50 (927)	18.25 (464)	0.88 (22)	3.88 (98)	21.00 (533)	18.75 (476)	5.00 (127)

Dimensions are subject to change. Not to be used for construction purposes unless certified.

Xylem Inc.
 8200 N. Austin Avenue
 Morton Grove, IL 60053
 Phone: (847)966-3700
 Fax: (847)965-8379
 www.gouldswatertechnology.com

