

<b>JOB:</b>    <b>UNIT TAG:</b> <b>ENGINEER:</b> <b>CONTRACTOR:</b>	<b>REPRESENTATIVE:</b>    <b>ORDER NO.:</b> <b>SUBMITTED BY:</b> <b>APPROVED BY:</b>	<b>DATE:</b> <b>DATE:</b> <b>DATE:</b>
---	--	--

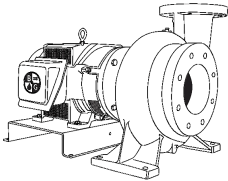

# 5-9D

## Marlow Series e-531SC

### Close-Coupled Centrifugal Pumps

**SPECIFICATIONS**

FLOW \_\_\_\_\_ HEAD \_\_\_\_\_  
 HP \_\_\_\_\_ RPM \_\_\_\_\_  
 VOLTS \_\_\_\_\_  
 CYCLE \_\_\_\_\_ PHASE \_\_\_\_\_  
 ENCLOSURE \_\_\_\_\_  
 APPROX. WEIGHT \_\_\_\_\_  
 SPECIALS \_\_\_\_\_

**MATERIALS OF CONSTRUCTION**

Stainless Steel Fitted

**MAXIMUM WORKING PRESSURE**

175 psi (12 bar) W.P.  
with 125# ANSI flange drilling

**TYPE OF SEAL**

- Standard Seal (Buna-Carbon/Ceramic)
- F Standard Seal w/ Flush Line (Buna-Carbon/Ceramic)
- S Stuffing Box Construction w/ Flushed Mechanical Single Seal EPR-Tungsten Carbide/Carbon)
- PF Stuffing Box Construction w/ Flushed Packing (Graphite Impregnated Teflon)

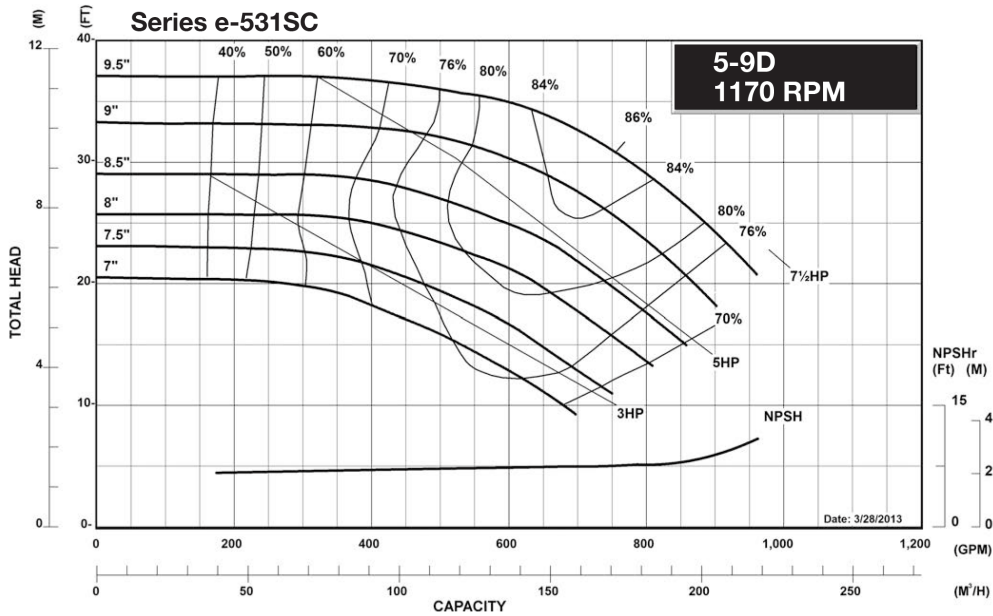

<b>JOB:</b>	<b>REPRESENTATIVE:</b>
<b>UNIT TAG:</b>	<b>ORDER NO.:</b>
<b>ENGINEER:</b>	<b>SUBMITTED BY:</b>
<b>CONTRACTOR:</b>	<b>APPROVED BY:</b>
	<b>DATE:</b>
	<b>DATE:</b>
	<b>DATE:</b>

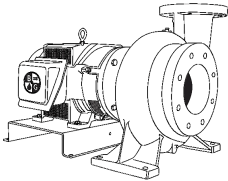

# 5-9D

## Marlow Series e-531SC

### Close-Coupled Centrifugal Pumps

**SPECIFICATIONS**

FLOW \_\_\_\_\_ HEAD \_\_\_\_\_

HP \_\_\_\_\_ RPM \_\_\_\_\_

VOLTS \_\_\_\_\_

CYCLE \_\_\_\_\_ PHASE \_\_\_\_\_

ENCLOSURE \_\_\_\_\_

APPROX. WEIGHT \_\_\_\_\_

SPECIALS \_\_\_\_\_

**MATERIALS OF CONSTRUCTION**

Stainless Steel Fitted

**MAXIMUM WORKING PRESSURE**

175 psi (12 bar) W.P.  
with 125# ANSI flange drilling

**TYPE OF SEAL**

- Standard Seal (Buna-Carbon/Ceramic)
- F Standard Seal w/ Flush Line (Buna-Carbon/Ceramic)
- S Stuffing Box Construction w/ Flushed Mechanical Single Seal (EPR-Tungsten Carbide/Carbon)
- PF Stuffing Box Construction w/ Flushed Packing (Graphite Impregnated Teflon)

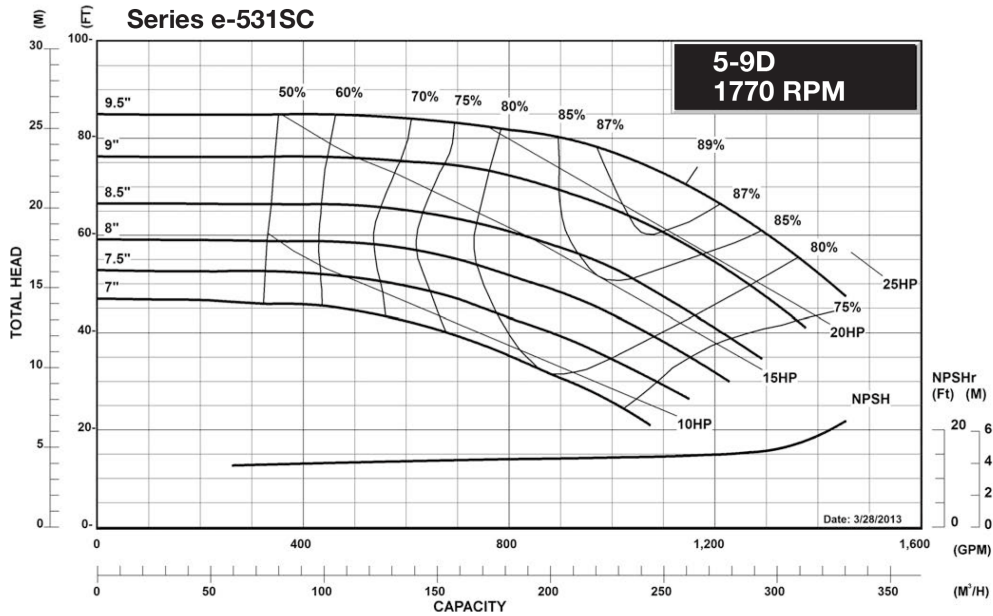

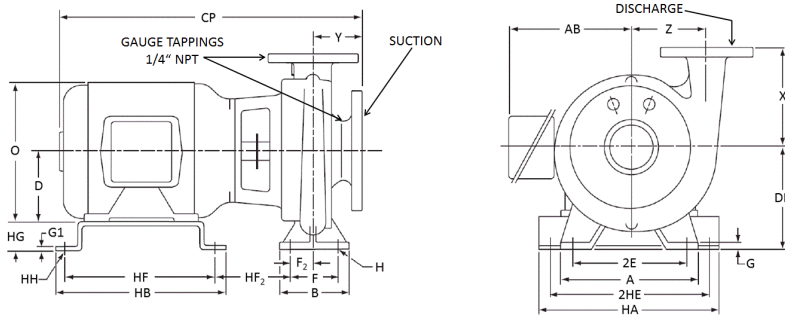

PUMP DIMENSIONS - INCHES (MM)		
X	Y	Z
10.00 (254)	6.00 (152)	7.50 (190)

FLANGE DIMENSIONS - INCHES (MM)						
125# ANSI FLAT FACE	NOMINAL PIPE SIZE	O.D.	THICKNESS	BOLT CIRCLE DIAMETER	NO. OF BOLTS	SIZE OF BOLTS
DISCHARGE	5	11.00 (279)	1.44 (37)	8.50 (216)	8	0.75 (19)
SUCTION	6	12.50 (318)	1.50 (38)	9.50 (241)	8	0.75 (19)

DIMENSIONS - INCHES (mm)

STANDARD SEAL

MOTOR FRAME	A	AB	HB	CP MAX	D	HF	G	G1	H	HH	HA	F2	2E	2HE	HF2 MAX	B	F	O	HG	DD
213JM	16.00 (406)	10.75 (273)	12.00 (305)	27.63 (702)	5.25 (133)	10.75 (273)	0.88 (22)	0.19 (5)	0.63 (16)	0.50 (13)	14.00 (356)	2.19 (56)	14.00 (356)	12.50 (318)	5.94 (151)	7.00 (178)	5.00 (127)	11.13 (283)	5.75 (146)	11.00 (279)
215JM	16.00 (406)	10.75 (273)	12.00 (305)	29.13 (740)	5.25 (133)	10.75 (273)	0.88 (22)	0.19 (5)	0.63 (16)	0.50 (13)	14.00 (356)	2.19 (56)	14.00 (356)	12.50 (318)	5.94 (151)	7.00 (178)	5.00 (127)	11.13 (283)	5.75 (146)	11.00 (279)
254JM	16.00 (406)	10.75 (273)	16.00 (406)	33.13 (841)	6.25 (159)	14.50 (368)	0.88 (22)	0.25 (6)	0.63 (16)	0.63 (16)	14.00 (356)	2.19 (56)	14.00 (356)	12.50 (318)	7.07 (179)	7.00 (178)	5.00 (127)	13.13 (333)	4.75 (121)	11.00 (279)
256JM	16.00 (406)	10.75 (273)	16.00 (406)	34.88 (886)	6.25 (159)	14.50 (368)	0.88 (22)	0.25 (6)	0.63 (16)	0.63 (16)	14.00 (356)	2.19 (56)	14.00 (356)	12.50 (318)	7.07 (179)	7.00 (178)	5.00 (127)	13.13 (333)	4.75 (121)	11.00 (279)
284JM	16.00 (406)	12.63 (321)	17.00 (432)	34.25 (870)	7.00 (178)	15.50 (394)	0.88 (22)	0.25 (6)	0.63 (16)	0.63 (16)	14.00 (356)	2.19 (56)	14.00 (356)	12.50 (318)	7.07 (179)	7.00 (178)	5.00 (127)	15.00 (381)	4.00 (102)	11.00 (279)

DIMENSIONS - INCHES (mm)

STUFFING BOX

MOTOR FRAME	A	AB	HB	CP MAX	D	HF	G	G1	H	HH	HA	F2	2E	2HE	HF2 MAX	B	F	O	HG	DD
213JP	16.00 (406)	10.75 (273)	12.00 (305)	31.50 (800)	5.25 (133)	10.75 (273)	0.88 (22)	0.19 (5)	0.63 (16)	0.50 (13)	14.00 (356)	2.19 (56)	14.00 (356)	12.50 (318)	9.81 (249)	7.00 (178)	5.00 (127)	11.13 (283)	5.75 (146)	11.00 (279)
215JP	16.00 (406)	10.75 (273)	12.00 (305)	33.00 (838)	5.25 (133)	10.75 (273)	0.88 (22)	0.19 (5)	0.63 (16)	0.50 (13)	14.00 (356)	2.19 (56)	14.00 (356)	12.50 (318)	9.81 (249)	7.00 (178)	5.00 (127)	11.13 (283)	5.75 (146)	11.00 (279)
254JP	16.00 (406)	10.75 (273)	16.00 (406)	36.00 (914)	6.25 (159)	14.50 (368)	0.88 (22)	0.25 (6)	0.63 (16)	0.63 (16)	14.00 (356)	2.19 (56)	14.00 (356)	12.50 (318)	9.94 (252)	7.00 (178)	5.00 (127)	13.13 (333)	4.75 (121)	11.00 (279)
256JP	16.00 (406)	10.75 (273)	16.00 (406)	37.75 (959)	6.25 (159)	14.50 (368)	0.88 (22)	0.25 (6)	0.63 (16)	0.63 (16)	14.00 (356)	2.19 (56)	14.00 (356)	12.50 (318)	9.94 (252)	7.00 (178)	5.00 (127)	13.13 (333)	4.75 (121)	11.00 (279)
284JP	16.00 (406)	12.63 (321)	17.00 (432)	37.13 (943)	7.00 (178)	15.50 (394)	0.88 (22)	0.25 (6)	0.63 (16)	0.63 (16)	14.00 (356)	2.19 (56)	14.00 (356)	12.50 (318)	9.94 (252)	7.00 (178)	5.00 (127)	15.00 (381)	4.00 (102)	11.00 (279)

Dimensions are subject to change. Not to be used for construction purposes unless certified.

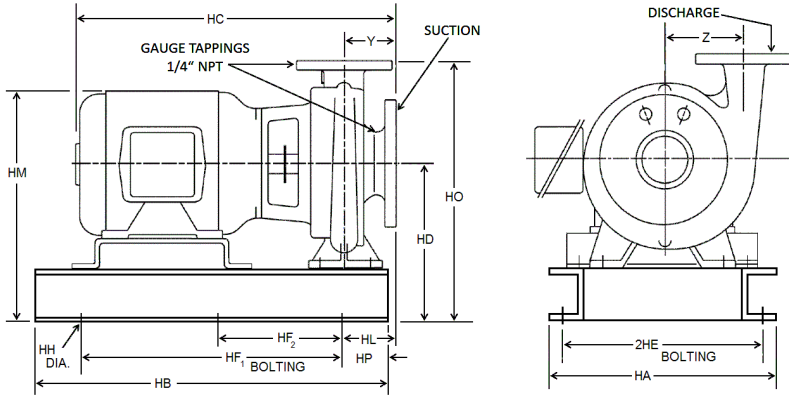

PUMP DIMENSIONS - INCHES (MM)	
Y	Z
6.00 (152)	7.50 (190)

FLANGE DIMENSIONS - INCHES (MM)						
125# ANSI FLAT FACE	NOMINAL PIPE SIZE	O.D.	THICKNESS	BOLT CIRCLE DIAMETER	NO. OF BOLTS	SIZE OF BOLTS
DISCHARGE	5	11.00 (279)	1.44 (37)	8.50 (216)	8	0.75 (19)
SUCTION	6	12.50 (318)	1.50 (38)	9.50 (241)	8	0.75 (19)

DIMENSIONS - INCHES (mm)

STANDARD SEAL

MOTOR FRAME	HA	HB	HC MAX	HD	2HE	HF1	HF2	HH	HL	HM MAX	HO	HP
213JM	16.00 (406)	46.50 (1181)	27.63 (702)	15.00 (381)	14.00 (356)	36.50 (927)	18.25 (464)	0.88 (22)	4.56 (116)	20.88 (530)	25.00 (635)	5.00 (127)
215JM	16.00 (406)	46.50 (1181)	29.13 (740)	15.00 (381)	14.00 (356)	36.50 (927)	18.25 (464)	0.88 (22)	4.56 (116)	20.88 (530)	25.00 (635)	5.00 (127)
254JM	16.00 (406)	46.50 (1181)	33.13 (841)	15.00 (381)	14.00 (356)	36.50 (927)	18.25 (464)	0.88 (22)	4.56 (116)	21.88 (556)	25.00 (635)	5.00 (127)
256JM	16.00 (406)	46.50 (1181)	34.88 (886)	15.00 (381)	14.00 (356)	36.50 (927)	18.25 (464)	0.88 (22)	6.44 (164)	21.88 (556)	25.00 (635)	5.00 (127)
284JM	16.00 (406)	46.50 (1181)	34.25 (870)	15.00 (381)	14.00 (356)	36.50 (927)	18.25 (464)	0.88 (22)	6.44 (164)	23.00 (584)	25.00 (635)	5.00 (127)

DIMENSIONS - INCHES (mm)

STUFFING BOX

MOTOR FRAME	HA	HB	HC MAX	HD	2HE	HF1	HF2	HH	HL	HM MAX	HO	HP
213JP	16.00 (406)	46.50 (1181)	31.50 (800)	15.00 (381)	14.00 (356)	36.50 (927)	18.25 (464)	0.88 (22)	6.44 (164)	20.88 (530)	25.00 (635)	5.00 (127)
215JP	16.00 (406)	46.50 (1181)	33.00 (838)	15.00 (381)	14.00 (356)	36.50 (927)	18.25 (464)	0.88 (22)	6.44 (164)	20.88 (530)	25.00 (635)	5.00 (127)
254JP	16.00 (406)	46.50 (1181)	36.00 (914)	15.00 (381)	14.00 (356)	36.50 (927)	18.25 (464)	0.88 (22)	6.44 (164)	21.88 (556)	25.00 (635)	5.00 (127)
256JP	16.00 (406)	46.50 (1181)	37.75 (959)	15.00 (381)	14.00 (356)	36.50 (927)	18.25 (464)	0.88 (22)	6.44 (164)	21.88 (556)	25.00 (635)	5.00 (127)
284JP	16.00 (406)	46.50 (1181)	37.13 (943)	15.00 (381)	14.00 (356)	36.50 (927)	18.25 (464)	0.88 (22)	6.44 (164)	23.00 (584)	25.00 (635)	5.00 (127)

Dimensions are subject to change. Not to be used for construction purposes unless certified.

Xylem Inc.  
 8200 N. Austin Avenue  
 Morton Grove, IL 60053  
 Phone: (847)966-3700  
 Fax: (847)965-8379  
 www.gouldswatertechnology.com

