

JOB: UNIT TAG: ENGINEER: CONTRACTOR:	REPRESENTATIVE: ORDER NO.: SUBMITTED BY: APPROVED BY:	DATE: DATE: DATE:
---	--	--

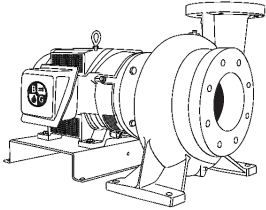

6-11

Marlow Series e-531SC

Close-Coupled Centrifugal Pumps

SPECIFICATIONS

FLOW _____ HEAD _____
 HP _____ RPM _____
 VOLTS _____
 CYCLE _____ PHASE _____
 ENCLOSURE _____
 APPROX. WEIGHT _____
 SPECIALS _____

MATERIALS OF CONSTRUCTION

Stainless Steel Fitted

MAXIMUM WORKING PRESSURE

175 psi (12 bar) W.P.
with 125# ANSI flange drilling

TYPE OF SEAL

- Standard Seal (Buna-Carbon/Ceramic)
- F Standard Seal w/ Flush Line (Buna-Carbon/Ceramic)
- S Stuffing Box Construction w/ Flushed Mechanical Single Seal (EPR-Tungsten Carbide/Carbon)
- PF Stuffing Box Construction w/ Flushed Packing (Graphite Impregnated Teflon)

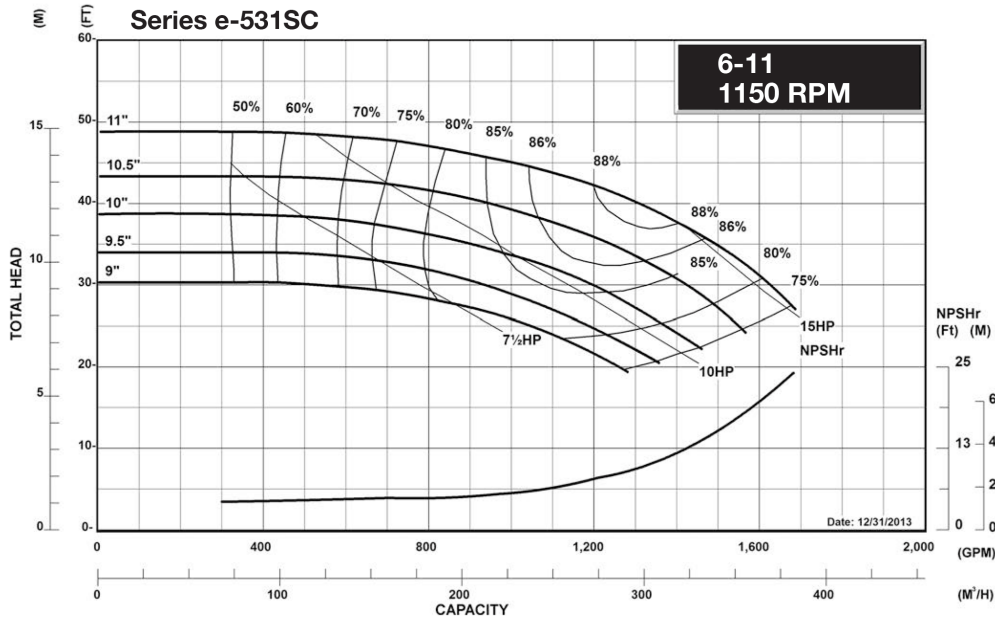

JOB: UNIT TAG: ENGINEER: CONTRACTOR:	REPRESENTATIVE: ORDER NO.: SUBMITTED BY: APPROVED BY:	DATE: DATE: DATE:
---	--	--

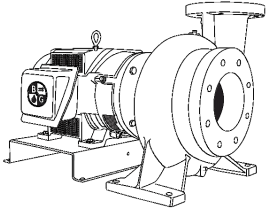

6-11

Marlow Series e-531SC

Close-Coupled Centrifugal Pumps

SPECIFICATIONS

FLOW _____ HEAD _____
 HP _____ RPM _____
 VOLTS _____
 CYCLE _____ PHASE _____
 ENCLOSURE _____
 APPROX. WEIGHT _____
 SPECIALS _____

MATERIALS OF CONSTRUCTION

Stainless Steel Fitted

MAXIMUM WORKING PRESSURE

175 psi (12 bar) W.P.
with 125# ANSI flange drilling

TYPE OF SEAL

- Standard Seal (Buna-Carbon/Ceramic)
- F Standard Seal w/ Flush Line (Buna-Carbon/Ceramic)
- S Stuffing Box Construction w/ Flushed Mechanical Single Seal (EPR-Tungsten Carbide/Carbon)
- PF Stuffing Box Construction w/ Flushed Packing (Graphite Impregnated Teflon)

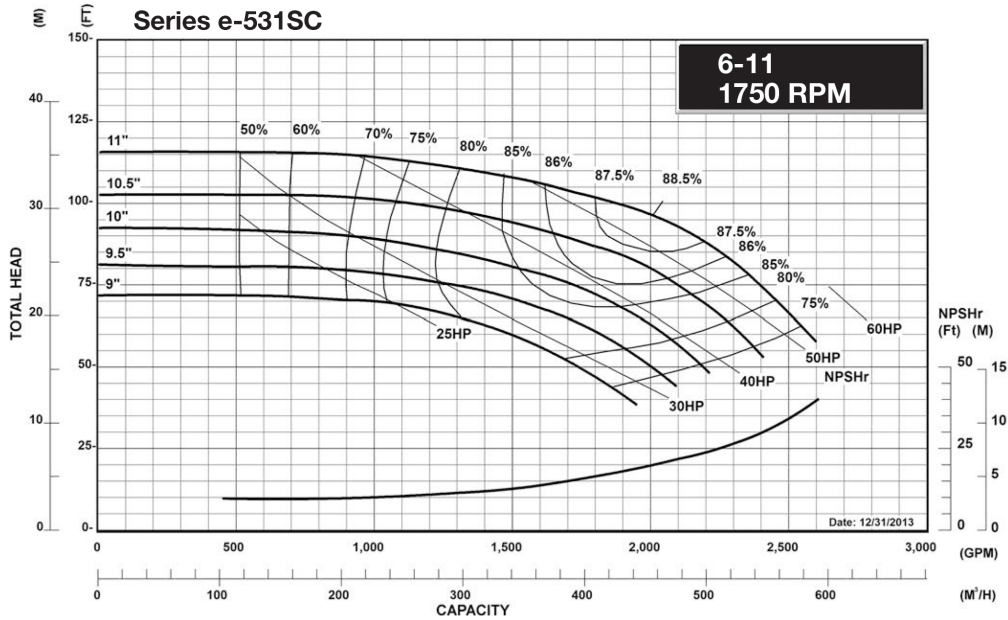

Marlow Series e-531SC 6-11 Centrifugal Pump Submittal

M-502.38

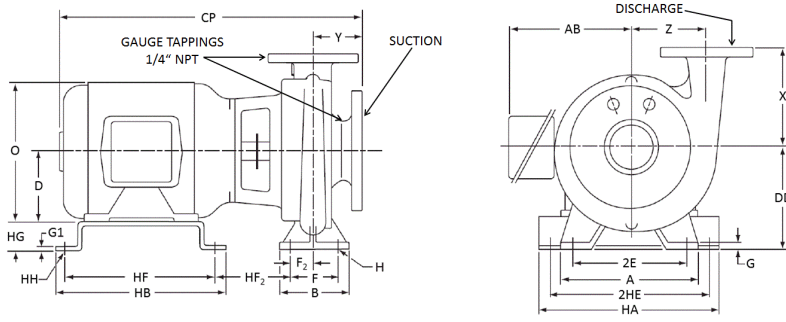

PUMP DIMENSIONS - INCHES (MM)		
X	Y	Z
11.00 (279)	6.13 (156)	8.47 (215)

FLANGE DIMENSIONS - INCHES (MM)						
125# ANSI FLAT FACE	NOMINAL PIPE SIZE	O.D.	THICKNESS	BOLT CIRCLE DIAMETER	NO. OF BOLTS	SIZE OF BOLTS
DISCHARGE	6	12.13 (308)	1.44 (37)	9.50 (241)	8	0.75 (19)
SUCTION	8	14.75 (375)	1.63 (41)	11.75 (298)	8	0.75 (19)

DIMENSIONS - INCHES (mm)

STANDARD SEAL

MOTOR FRAME	A	AB	HB	CP MAX	D	HF	G	G1	H	HH	HA	F2	2E	2HE	HF2 MAX	B	F	O	HG	DD
254JM	23.00 (584)	10.75 (273)	16.13 (410)	32.05 (814)	6.25 (159)	14.88 (378)	1.00 (25.4)	0.25 (6)	0.88 (22)	0.63 (16)	22.25 (565)	4.63 (118)	21.00 (533)	21.00 (533)	3.32 (82)	11.00 (279)	9.00 (229)	13.13 (333)	5.75 (146)	12.00 (305)
256JM	23.00 (584)	10.75 (273)	16.13 (410)	33.80 (859)	6.25 (159)	14.88 (378)	1.00 (25.4)	0.25 (6)	0.88 (22)	0.63 (16)	22.25 (565)	4.63 (118)	21.00 (533)	21.00 (533)	3.22 (82)	11.00 (279)	9.00 (229)	13.13 (333)	5.75 (146)	12.00 (305)
284JM	23.00 (584)	12.63 (321)	20.25 (514)	33.30 (846)	7.00 (178)	18.25 (464)	1.00 (25.4)	0.25 (6)	0.88 (22)	0.63 (16)	23.00 (584)	4.63 (118)	21.00 (533)	21.00 (533)	2.06 (52)	11.00 (279)	9.00 (229)	15.00 (381)	5.00 (127)	12.00 (305)
286JM	23.00 (584)	12.63 (321)	20.25 (514)	34.80 (886)	7.00 (178)	18.25 (464)	1.00 (25.4)	0.25 (6)	0.88 (22)	0.63 (16)	23.00 (584)	4.63 (118)	21.00 (533)	21.00 (533)	2.06 (52)	11.00 (279)	9.00 (229)	15.00 (381)	5.00 (127)	12.00 (305)
324JM	23.00 (584)	15.13 (384)	19.00 (483)	36.30 (922)	8.00 (203)	17.50 (444)	1.00 (25.4)	0.25 (6)	0.88 (22)	0.63 (16)	22.50 (572)	4.63 (118)	21.00 (533)	21.00 (533)	3.41 (87)	11.00 (279)	9.00 (229)	17.00 (432)	4.00 (102)	12.00 (305)
326JM	23.00 (584)	15.13 (384)	19.00 (483)	37.80 (960)	8.00 (203)	17.50 (444)	1.00 (25.4)	0.25 (6)	0.88 (22)	0.63 (16)	22.50 (572)	4.63 (118)	21.00 (533)	21.00 (533)	3.41 (87)	11.00 (279)	9.00 (229)	17.00 (432)	4.00 (102)	12.00 (305)

DIMENSIONS - INCHES (mm)

STUFFING BOX

MOTOR FRAME	A	AB	HB	CP MAX	D	HF	G	G1	H	HH	HA	F2	2E	2HE	HF2 MAX	B	F	O	HG	DD
254JP	23.00 (584)	10.75 (273)	16.13 (410)	34.88 (886)	6.25 (159)	14.88 (378)	1.00 (25.4)	0.25 (6)	0.88 (22)	0.63 (16)	22.25 (565)	4.63 (118)	21.00 (533)	21.00 (533)	6.05 (154)	11.00 (279)	9.00 (229)	13.13 (333)	5.75 (146)	12.00 (305)
256JP	23.00 (584)	10.75 (273)	16.13 (410)	36.63 (930)	6.25 (159)	14.88 (378)	1.00 (25.4)	0.25 (6)	0.88 (22)	0.63 (16)	22.25 (565)	4.63 (118)	21.00 (533)	21.00 (533)	6.05 (154)	11.00 (279)	9.00 (229)	13.13 (333)	5.75 (146)	12.00 (305)
284JP	23.00 (584)	12.63 (321)	20.25 (514)	36.13 (918)	7.00 (178)	18.25 (464)	1.00 (25.4)	0.25 (6)	0.88 (22)	0.63 (16)	23.00 (584)	4.63 (118)	21.00 (533)	21.00 (533)	4.87 (124)	11.00 (279)	9.00 (229)	15.00 (381)	5.00 (127)	12.00 (305)
286JP	23.00 (584)	12.63 (321)	20.25 (514)	37.63 (956)	7.00 (178)	18.25 (464)	1.00 (25.4)	0.25 (6)	0.88 (22)	0.63 (16)	23.00 (584)	4.63 (118)	21.00 (533)	21.00 (533)	4.87 (124)	11.00 (279)	9.00 (229)	15.00 (381)	5.00 (127)	12.00 (305)
324JP	23.00 (584)	15.13 (384)	19.00 (483)	39.13 (994)	8.00 (203)	17.50 (444)	1.00 (25.4)	0.25 (6)	0.88 (22)	0.63 (16)	22.50 (572)	4.63 (118)	21.00 (533)	21.00 (533)	6.24 (158)	11.00 (279)	9.00 (229)	17.00 (432)	4.00 (102)	12.00 (305)
326JP	23.00 (584)	15.13 (384)	19.00 (483)	40.63 (1032)	8.00 (203)	17.50 (444)	1.00 (25.4)	0.25 (6)	0.88 (22)	0.63 (16)	22.50 (572)	4.63 (118)	21.00 (533)	21.00 (533)	6.24 (158)	11.00 (279)	9.00 (229)	17.00 (432)	4.00 (102)	12.00 (305)

Dimensions are subject to change. Not to be used for construction purposes unless certified.

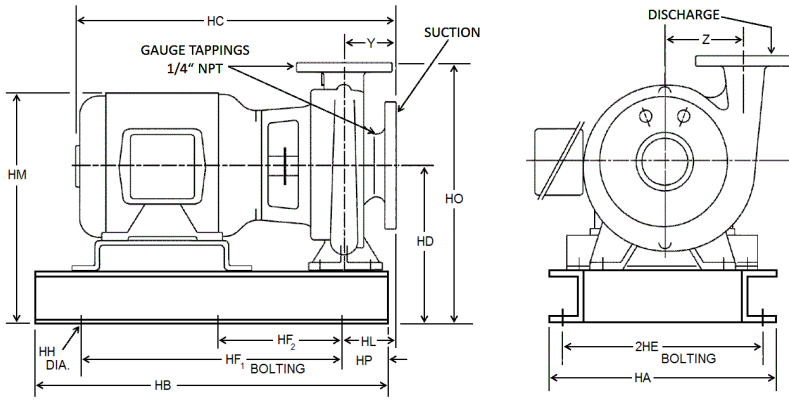

PUMP DIMENSIONS - INCHES (MM)	
Y	Z
6.13 (156)	8.47 (215)

FLANGE DIMENSIONS - INCHES (MM)						
125# ANSI FLAT FACE	NOMINAL PIPE SIZE	O.D.	THICKNESS	BOLT CIRCLE DIAMETER	NO. OF BOLTS	SIZE OF BOLTS
DISCHARGE	6	12.13 (308)	1.44 (37)	9.50 (241)	8	0.75 (19)
SUCTION	8	14.75 (375)	1.63 (41)	11.75 (298)	8	0.75 (19)

DIMENSIONS - INCHES (mm)

STANDARD SEAL

MOTOR FRAME	HA	HB	HC MAX	HD	2HE	HF1	HF2	HH	HL	HM MAX	HO	HP
254JM	24.00 (610)	56.00 (1422)	32.05 (814)	16.50 (419)	21.50 (546)	44.00 (1118)	22.00 (559)	1.00 (25)	6.00 (152)	23.38 (594)	27.50 (698)	6.00 (152)
256JM	24.00 (610)	56.00 (1422)	33.80 (859)	16.50 (419)	21.50 (546)	44.00 (1118)	22.00 (559)	1.00 (25)	6.00 (152)	23.38 (594)	27.50 (698)	6.00 (152)
284JM	24.00 (610)	56.00 (1422)	33.30 (846)	16.50 (419)	21.50 (546)	44.00 (1118)	22.00 (559)	1.00 (25)	6.00 (152)	24.50 (622)	27.50 (698)	6.00 (152)
286JM	24.00 (610)	56.00 (1422)	34.80 (884)	16.50 (419)	21.50 (546)	44.00 (1118)	22.00 (559)	1.00 (25)	6.00 (152)	24.50 (622)	27.50 (698)	6.00 (152)
324JM	24.00 (610)	56.00 (1422)	36.30 (922)	16.50 (419)	21.50 (546)	44.00 (1118)	22.00 (559)	1.00 (25)	6.00 (152)	25.63 (651)	27.50 (698)	6.00 (152)
326JM	24.00 (610)	56.00 (1422)	37.80 (960)	16.50 (419)	21.50 (546)	44.00 (1118)	22.00 (559)	1.00 (25)	6.00 (152)	25.63 (651)	27.50 (698)	6.00 (152)

DIMENSIONS - INCHES (mm)

STUFFING BOX

MOTOR FRAME	HA	HB	HC MAX	HD	2HE	HF1	HF2	HH	HL	HM MAX	HO	HP
254JP	24.00 (610)	56.00 (1422)	34.88 (886)	16.50 (419)	21.50 (546)	44.00 (1118)	22.00 (559)	1.00 (25)	6.00 (152)	23.38 (594)	27.50 (698)	6.00 (152)
256JP	24.00 (610)	56.00 (1422)	36.63 (930)	16.50 (419)	21.50 (546)	44.00 (1118)	22.00 (559)	1.00 (25)	6.00 (152)	23.38 (594)	27.50 (698)	6.00 (152)
284JP	24.00 (610)	56.00 (1422)	36.13 (918)	16.50 (419)	21.50 (546)	44.00 (1118)	22.00 (559)	1.00 (25)	6.00 (152)	24.50 (622)	27.50 (698)	6.00 (152)
286JP	24.00 (610)	56.00 (1422)	37.63 (956)	16.50 (419)	21.50 (546)	44.00 (1118)	22.00 (559)	1.00 (25)	6.00 (152)	24.50 (622)	27.50 (698)	6.00 (152)
324JP	24.00 (610)	56.00 (1422)	39.13 (994)	16.50 (419)	21.50 (546)	44.00 (1118)	22.00 (559)	1.00 (25)	6.00 (152)	25.63 (651)	27.50 (698)	6.00 (152)
326JP	24.00 (610)	56.00 (1422)	40.63 (1032)	16.50 (419)	21.50 (546)	44.00 (1118)	22.00 (559)	1.00 (25)	6.00 (152)	25.63 (651)	27.50 (698)	6.00 (152)

Dimensions are subject to change. Not to be used for construction purposes unless certified.

Xylem Inc.
 8200 N. Austin Avenue
 Morton Grove, IL 60053
 Phone: (847)966-3700
 Fax: (847)965-8379
 www.gouldswatertechnology.com

