



e-GS Xtreme™ CBM

60 Hz, 4" submersible pumps

Features

Field proven design: Xylem's e-GS Xtreme by Goulds Water Technology features super strong construction due to the welded casing joints at both ends. The proprietary engineered polymer bearings have been field proven with great success in some of the toughest submersible pump applications on the planet – coalbed methane extraction. They are the deepest set pumps we build, available up to 10 HP in many models. Capable of pumping over 1600' TDH.

Powered for continuous operation: All ratings are within the working limits of the motor as recommended by the motor manufacturer. Pump can be operated continuously without damage to the motor.

Sand handling design: Our face clearance, floating impeller stack has proven itself for over 50 years as a superior sand handling, durable pump design.

Stainless steel metal parts: AISI types 302, 303 and 304 are corrosion resistant, non-toxic and non-leaching.

FDA compliant non-metallic parts: Impellers, diffusers and bearing spiders are constructed of glass filled engineered composites. They are corrosion resistant and non-toxic.

Discharge head: Cast stainless steel discharge head features built-in safety loops and an upthrust limiting stud which is factory set to prevent the rotating assembly from upthrusting. These pumps require a separate field installed external check valve to prevent backflow.

"GS" series materials of construction

Part name	Material
Discharge head	AISI 303 SS
Bearing spider – upper	Glass filled engineered composite
Bearing	Proprietary engineered composite
Klipring	AISI 301 SS
Diffuser	Glass filled engineered composite*
Impeller	Glass filled engineered composite
Bowl	AISI 304 SS
Intermediate sleeve*	AISI 304 SS, Powder metal
Intermediate shaft coupling*	AISI 304 SS, Powder metal
Intermediate bearing spider*	Glass filled engineered composite
Intermediate bearing spider*	AISI 303 SS
Shim	AISI 304 SS
Screws – cable guard	AISI 304 SS
Motor adapter	AISI 303 SS
Casing	AISI 304 SS
Shaft (up to 3 hp)	
Shaft (5 hp and larger)	17/4 PH
Coupling	AISI 304 SS, Powder metal
Cable guard	AISI 304 SS
Suction screen	AISI 304 SS

* Used on models 35GS, 45GS, 65GS and 85GS

Bowls: Stainless steel for strength and abrasive resistance.

Check valve: Not supplied, order separately, pumps have 2" NPT discharge threads.

Stainless steel casing: Polished stainless steel is strong, attractive and corrosion resistant.

Hex shaft design: Six sided shafts for positive impeller drive.

Shaft coupling: Exposed for ease of field alignment to motor shaft and to check pump rotation.

Bearings: Proprietary engineered polymer bearing material is a super strong, abrasion and heat resistant design.

Models and specifications

Model	flow range GPM	HP range	best eff. GPM	Discharge connection	Minimum well size
5GS	1.2 – 7.5	½ – 3	5	2"	4"
7GS	1.5 – 10	½ – 5	7	2"	4"
10GS	3 – 16	1 – 5	10	2"	4"
18GS	6 – 28	1 – 10	18	2"	4"
25GS	8 – 33	1 – 10	25	2"	4"
35GS	10 – 50	1 – 10	35	2"	4"
45GS	20 – 65	1½ – 10	45	2"	4"
65GS	20 – 80	1½ – 10	65	2"	4"
85GS	40 – 100	3 – 10	85	2"	4"

Rotation on all units is counterclockwise when viewed from pump discharge end.

An optional 4" x 6" adapter – part no. **ADAPT46** is available for installations where a 6" motor is desired. The kit contains a 4" x 6" adapter, a 4" to 6" splined shaft extension and required bolts.

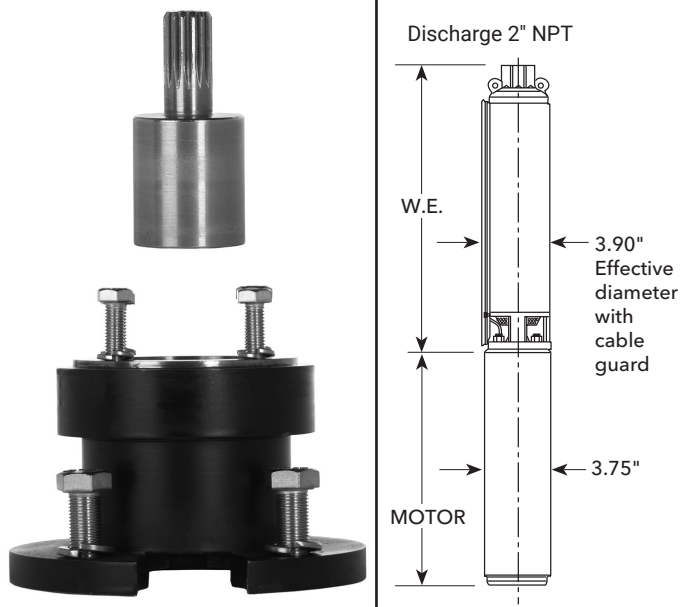

Dimensions and weights (All dimensions are in ins./mm. and weights are in lbs./kgs. Do not use for construction purposes.)

Model	HP	Stages	Length		Weight	
			In.	mm.	lb.	kg.
5GS05CBM	½	12	14.8	375.9	9	4.1
5GS07CBM	¾	15	16.8	426.7	10	4.5
5GS10CBM	1	20	20	508.0	12	5.4
5GS15CBM	1.5	26	25.3	642.6	15	6.8
5GS20CBM	2	33	30.1	764.5	19	8.6
5GS30CBM	3	46	42.7	1084.6	25	11.3
7GS05CBM	½	10	13.3	337.8	8	3.6
7GS07CBM	¾	13	15.4	391.2	10	4.5
7GS10CBM	1	17	18.3	464.8	11	5.0
7GS15CBM	1.5	22	21.9	556.3	13	5.9
7GS20CBM	2	27	26.6	675.6	16	7.3
7GS30CBM	3	34	31.6	802.6	20	9.1
7GS50CBM	5	54	49.6	1259.8	28	12.7
10GS10CBM	1	16	14.4	365.8	10	4.5
10GS15CBM	1.5	17	17.9	454.7	12	5.4
10GS20CBM	2	20	20	508.0	13	5.9
10GS30CBM	3	27	26	660.4	17	7.7
10GS50RCBM	5	35	32.5	825.5	21	9.5
10GS50CBM	5	42	36.3	922.0	22	10.0
18GS10CBM	1	8	13	330.2	8	3.6
18GS15CBM	1.5	11	15.5	393.7	10	4.5
18GS20CBM	2	14	18.1	459.7	11	5.0
18GS30CBM	3	19	22.4	569.0	13	5.9
18GS50RCBM	5	24	27.8	706.1	16	7.3
18GS50CBM	5	30	33.9	861.1	19	8.6
18GS75CBM	7.5	45	46.7	1186.2	30	13.6
18GS100CBM	10	60	61.7	1567.2	39	17.7
25GS10CBM	1	7	12.8	325.1	7	3.2
25GS15CBM	1.5	9	14.6	370.8	9	4.1

Model	HP	Stages	Length		Weight	
			In.	mm.	lb.	kg.
25GS20CBM	2	11	16.5	419.1	10	4.5
25GS30CBM	3	15	20.2	513.1	12	5.4
25GS50RCBM	5	22	28	711.2	16	7.3
25GS50CBM	5	26	30.9	784.9	19	8.6
25GS75CBM	7.5	34	40.5	1028.7	24	10.9
25GS100CBM	10	50	58	1473.2	31	14.1
35GS10CBM	1	6	14.2	360.7	8	3.6
35GS15CBM	1.5	8	16.6	421.6	9	4.1
35GS20CBM	2	10	19.1	485.1	10	4.5
35GS30CBM	3	14	24	609.6	13	5.9
35GS50CBM	5	23	36.4	924.6	20	9.1
35GS75CBM	7.5	36	53	1346.2	28	12.7
35GS100CBM	10	46	65.2	1656.1	34	15.4
45GS15CBM	1.5	5	12.9	327.7	8	3.6
45GS20CBM	2	7	15.4	391.2	9	4.1
45GS30CBM	3	10	19	482.6	10	4.5
45GS50CBM	5	17	27.7	703.6	15	6.8
45GS75CBM	7.5	25	38.9	988.1	21	9.5
45GS100CBM	10	34	50.6	1285.2	27	12.2
65GS15CBM	1.5	6	19.1	485.1	10	4.5
65GS20CBM	2	7	21.2	538.5	11	5.0
65GS30CBM	3	10	27.4	696.0	12	5.4
65GS50CBM	5	16	41.2	1046.5	18	8.2
65GS75CBM	7.5	26	62.3	1582.4	35	15.9
65GS100CBM	10	33	76.8	1950.7	42	19.0
85GS30CBM	3	8	29.4	746.8	13	5.9
85GS50CBM	5	14	42.8	1087.1	18	8.2
85GS75CBM	7.5	21	63.8	1620.5	35	15.9
85GS100CBM	10	27	79.9	2029.5	41	18.6

Goulds 4" single phase motors

Order no.	Type	HP	Volts	Length		Weight	
				in.	mm.	lb.	kg.
M05421	2-wire PSC	½	115	11.0	279	19.2	8.7
M05422		¾		11.0	279	19.2	8.7
M07422		1		12.4	314	22.7	10.3
M10422		1.5		13.3	337	24.5	11.1
M15422		2		14.9	378	28.9	13.1
M05411	3-wire	½	115	10.0	253	18.9	8.6
M05412		¾		9.7	246	18.1	8.2
M07412		1		10.8	275	21.4	9.7
M10412		1.5		11.7	297	23.1	10.5
M15412		2		13.6	345	27.4	12.4
M20412		3		15.1	383	31.0	14.1
M30412		5		18.3	466	40.0	18.1
M50412		10		27.7	703	70.0	31.8

Goulds 4" three phase motors

Order no.	HP	Volts	Length		Weight		
			In.	mm.	lb.	kg.	
M05430	½	200	10.8	275	22	9.7	
M07430	¾		10.8	275	22	9.7	
M10430	1		11.7	297	23.1	10.5	
M15430	1.5		11.7	297	23.1	10.5	
M20430	2		13.8	351	27.4	12.4	
M30430	3		15.3	389	32	14.5	
M50430	5		21.7	550	55	24.9	
M75430	7½		27.7	703	70	31.8	
M05432	½		230	10.8	275	22	9.7
M07432	¾			10.8	275	22	9.7
M10432	1	11.7		297	23.1	10.5	
M15432	1.5	11.7		297	23.1	10.5	
M20432	2	13.8		351	27.4	12.4	
M30432	3	15.3		389	32	14.5	
M50432	5	21.7		550	55	24.9	
M75432	7½	27.7		703	70	31.8	
M05434	½	460		10.8	275	22	9.7
M07434	¾			10.8	275	22	9.7
M10434	1		11.7	297	23.1	10.5	
M15434	1.5		11.7	297	23.1	10.5	
M20434	2		13.8	351	27.4	12.4	
M30434	3		15.3	389	32	14.5	
M50434	5		21.7	550	55	24.9	
M75434	7½		27.7	703	70	31.8	
M100434	10		30.7	780	78	35.4	

Order number code

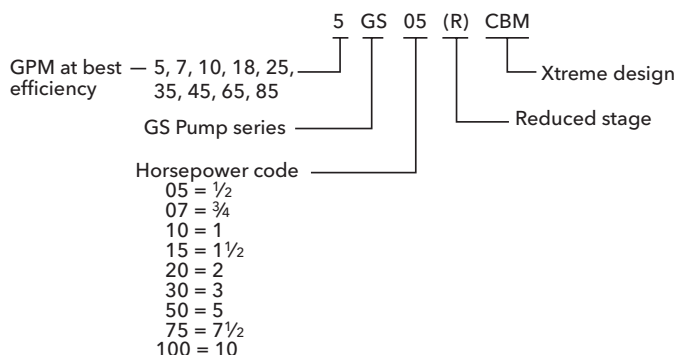

5GSCBM curve

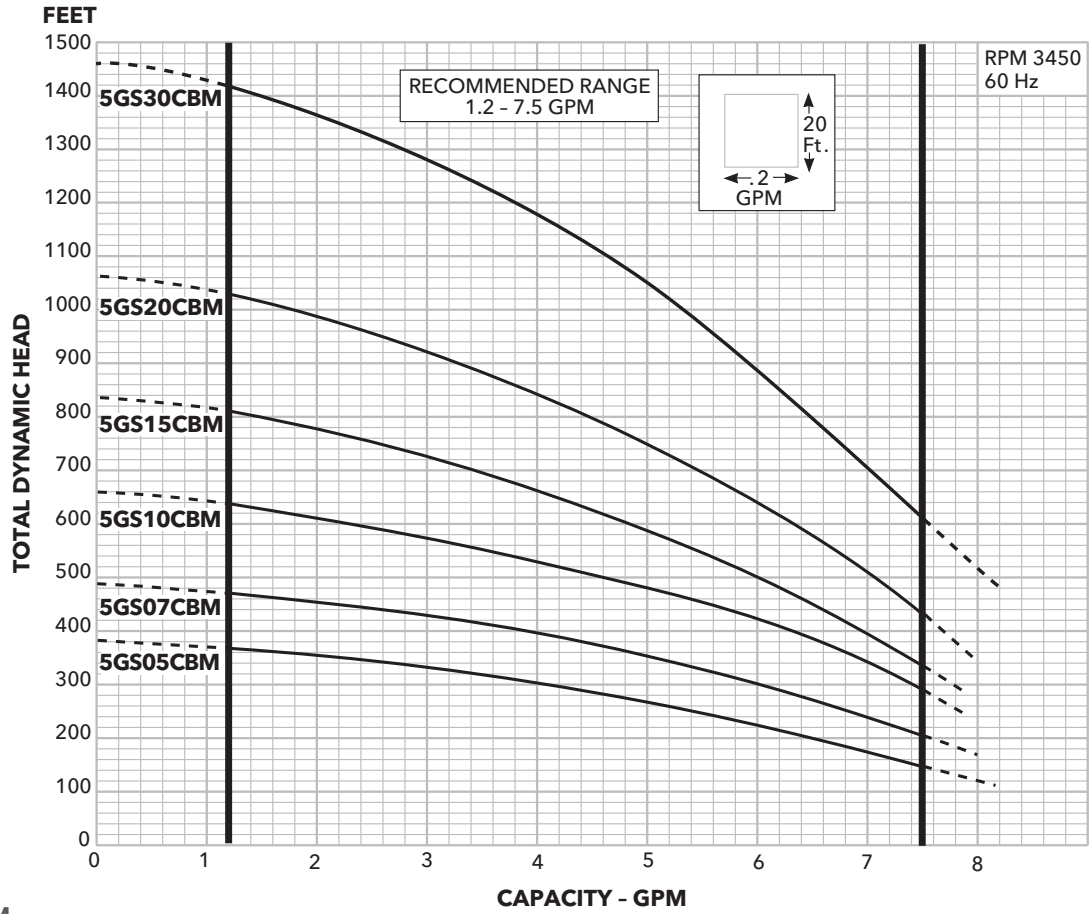

7GSCBM curve

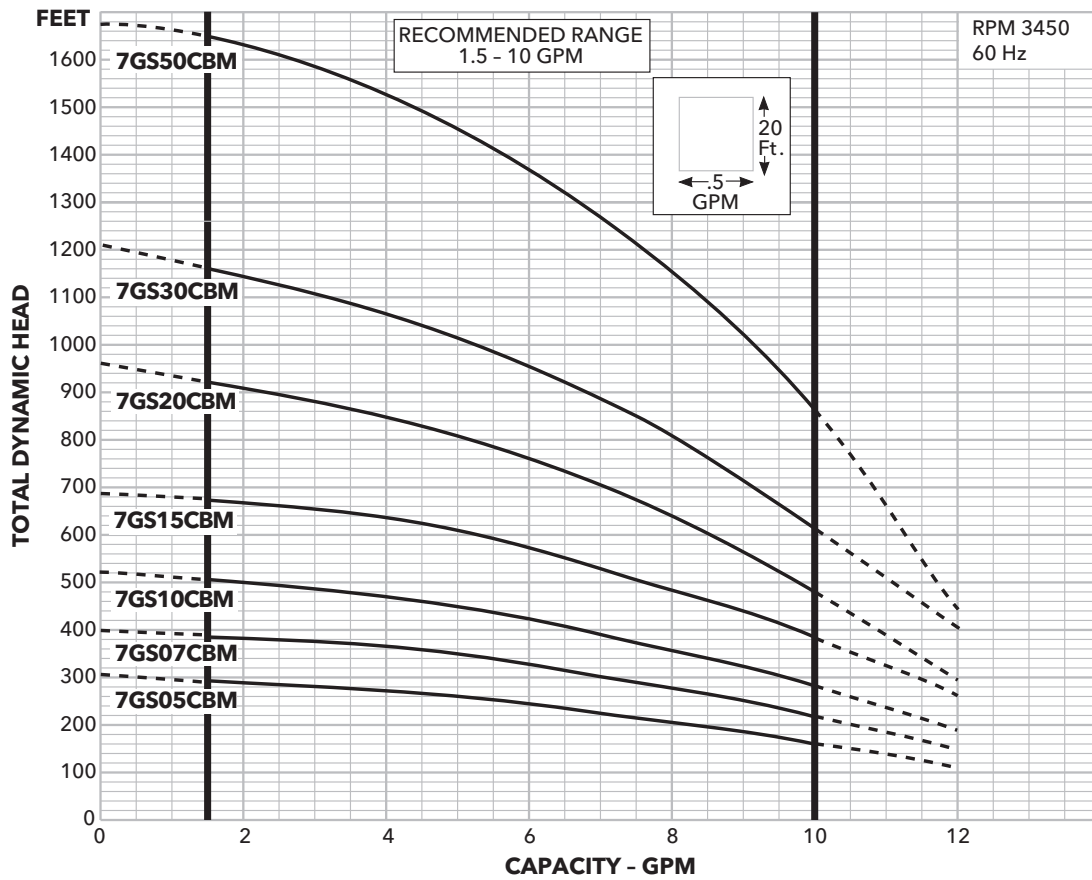

10GSCBM curve

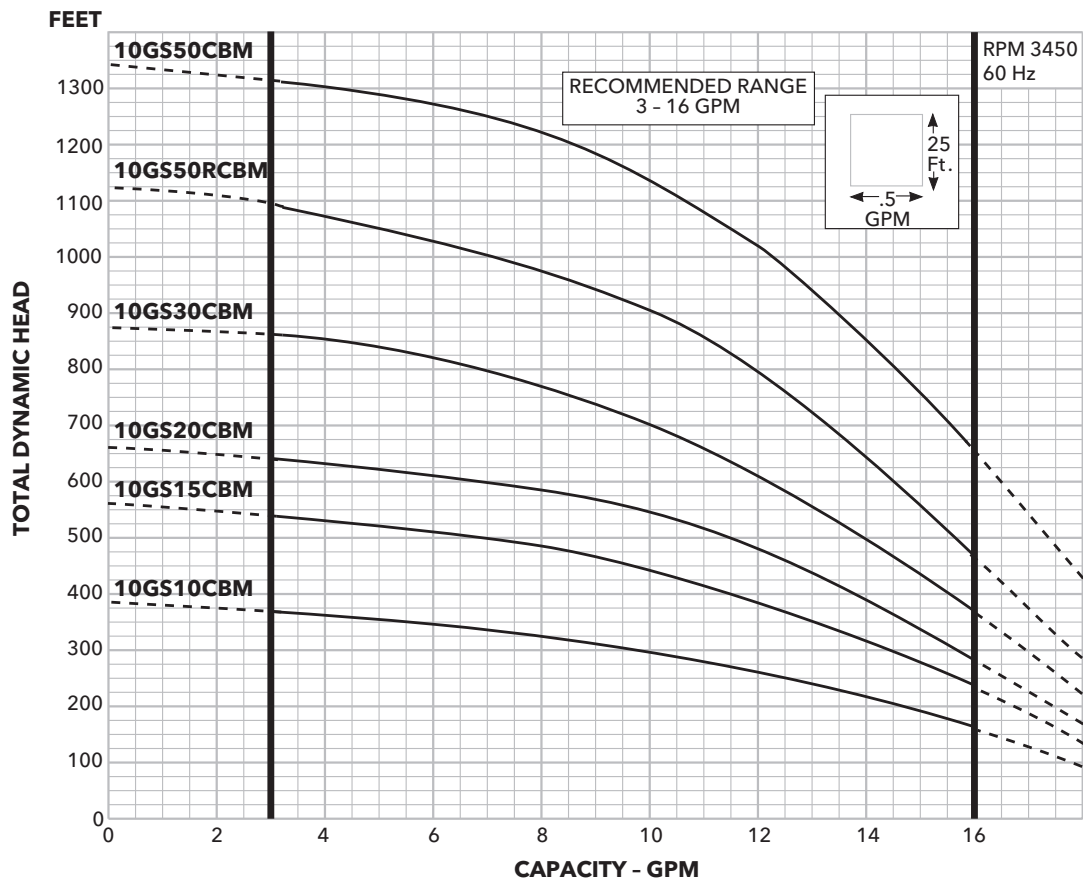

18GSCBM curve

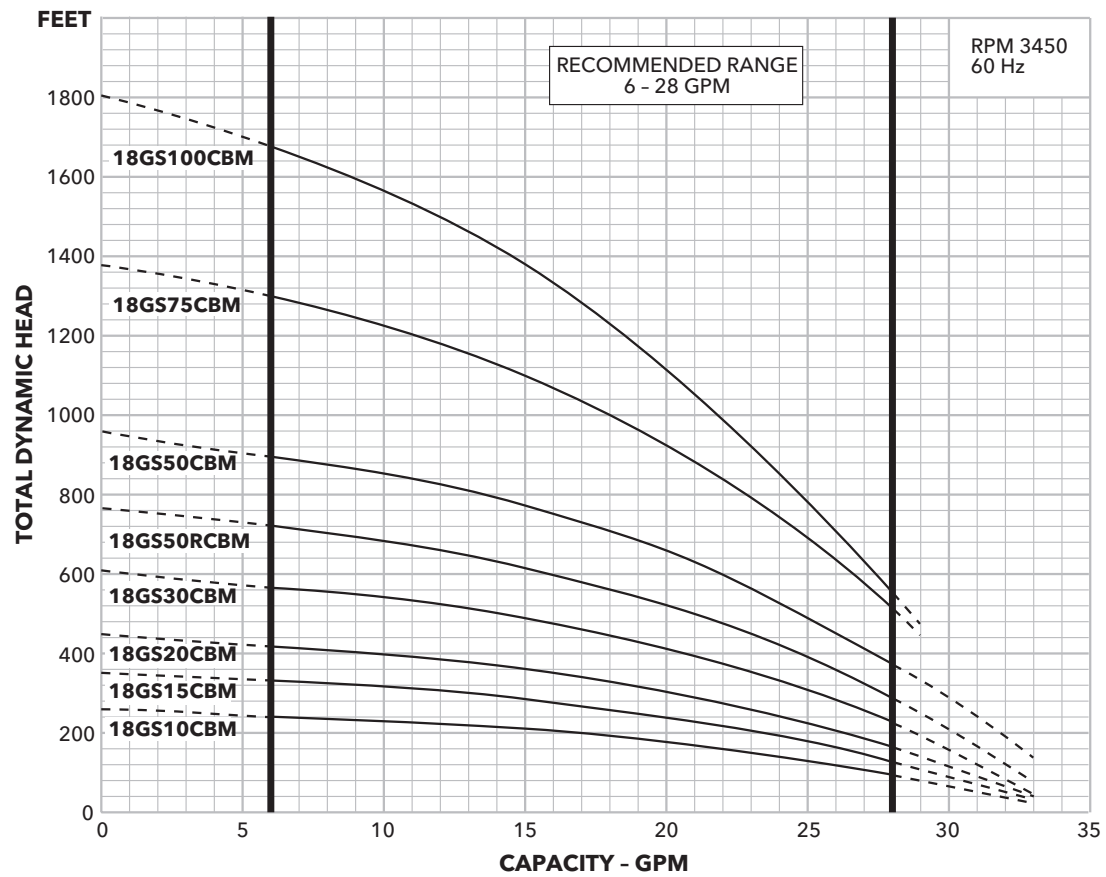

25GSCBM curve

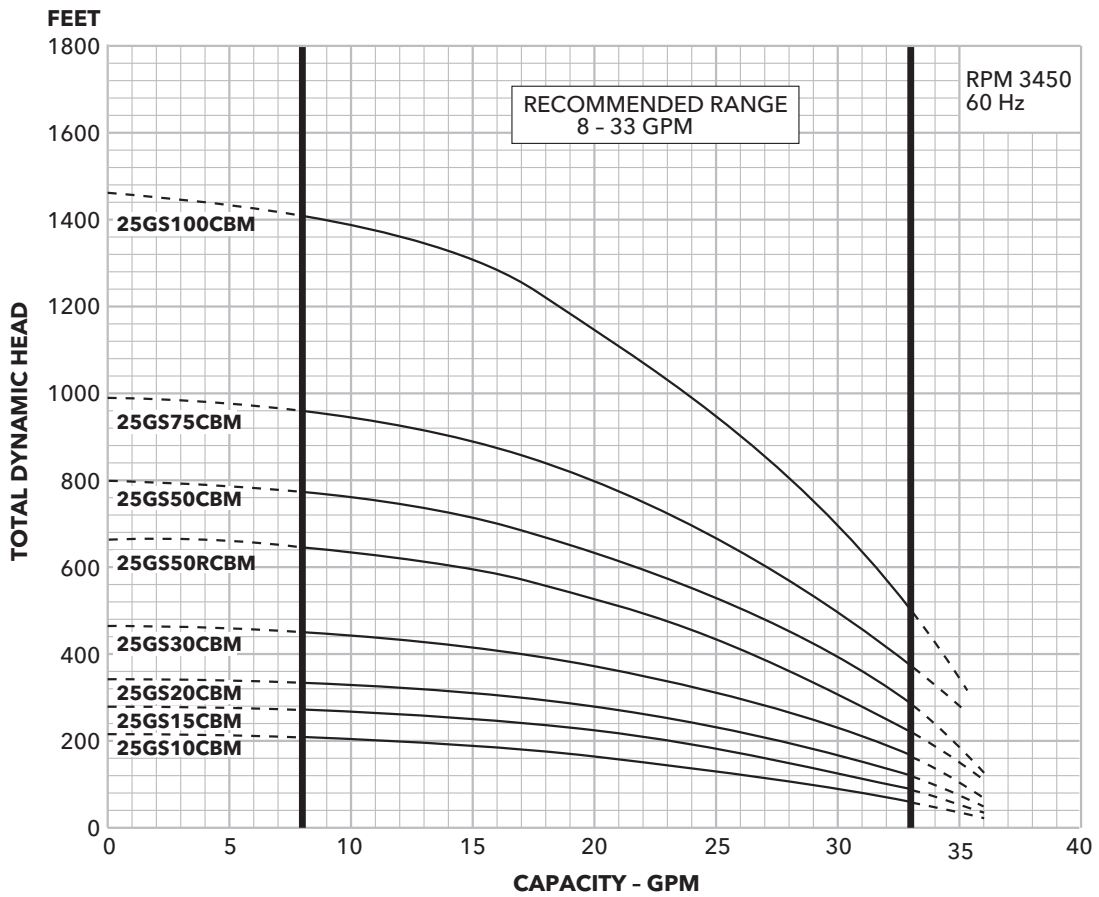

35GSCBM curve

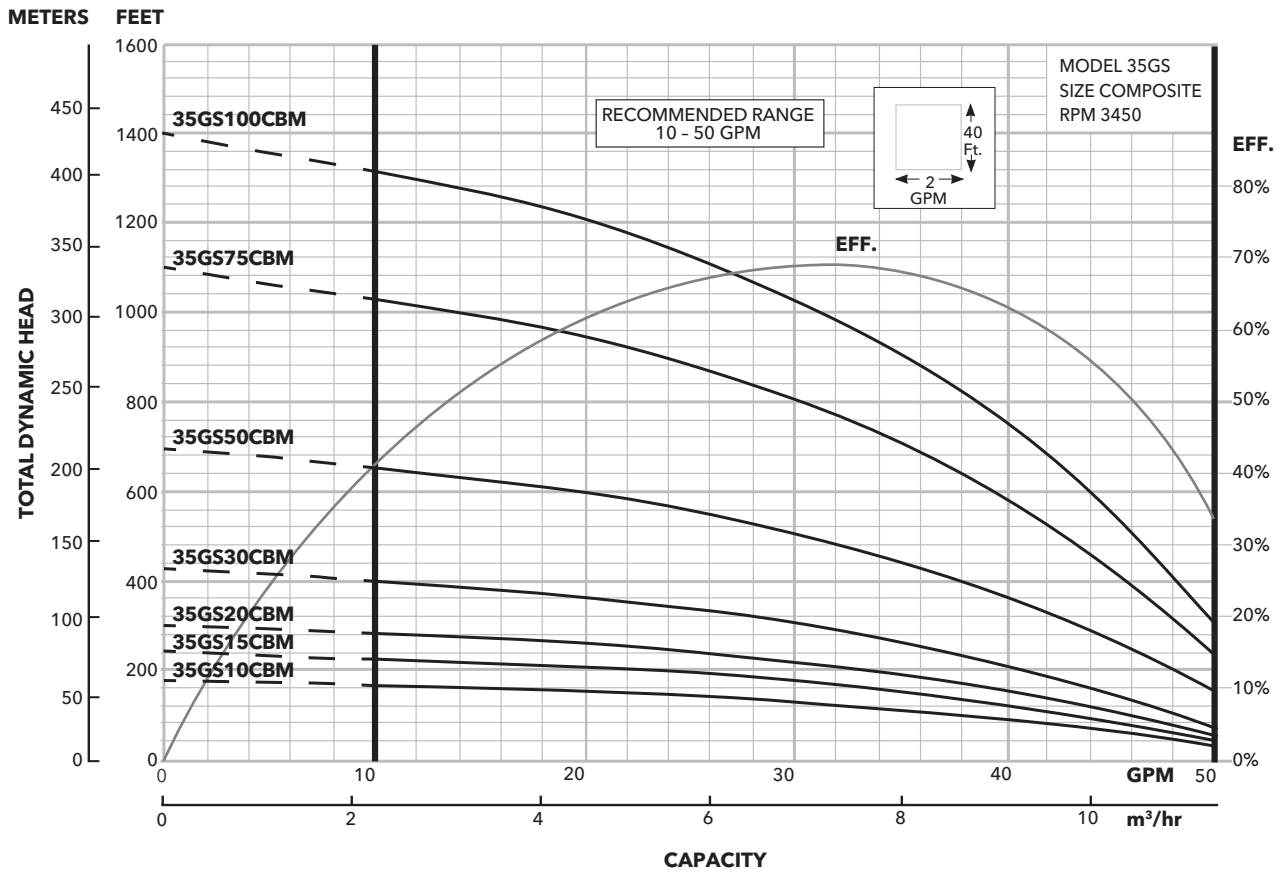

45GSCBM curve

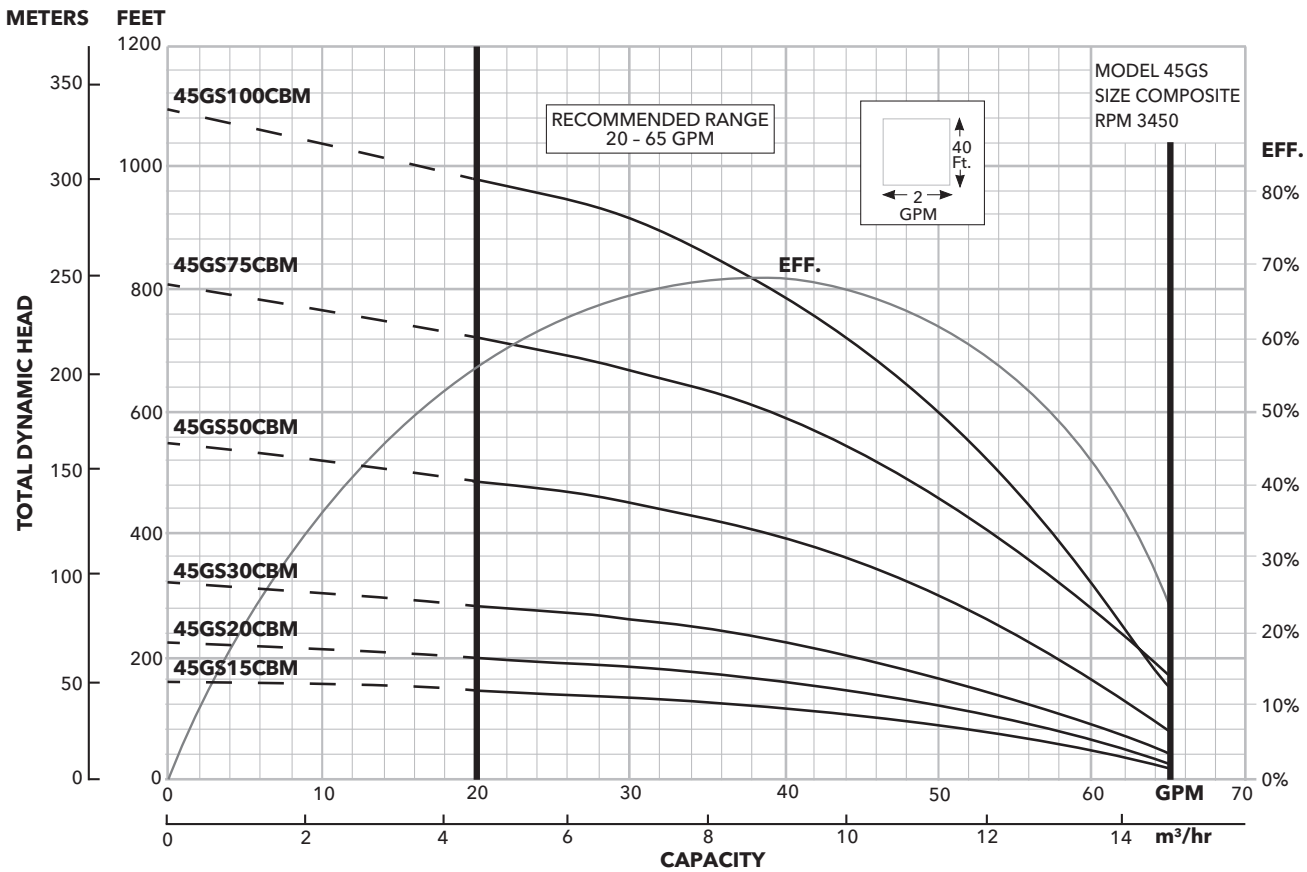

65GSCBM curve

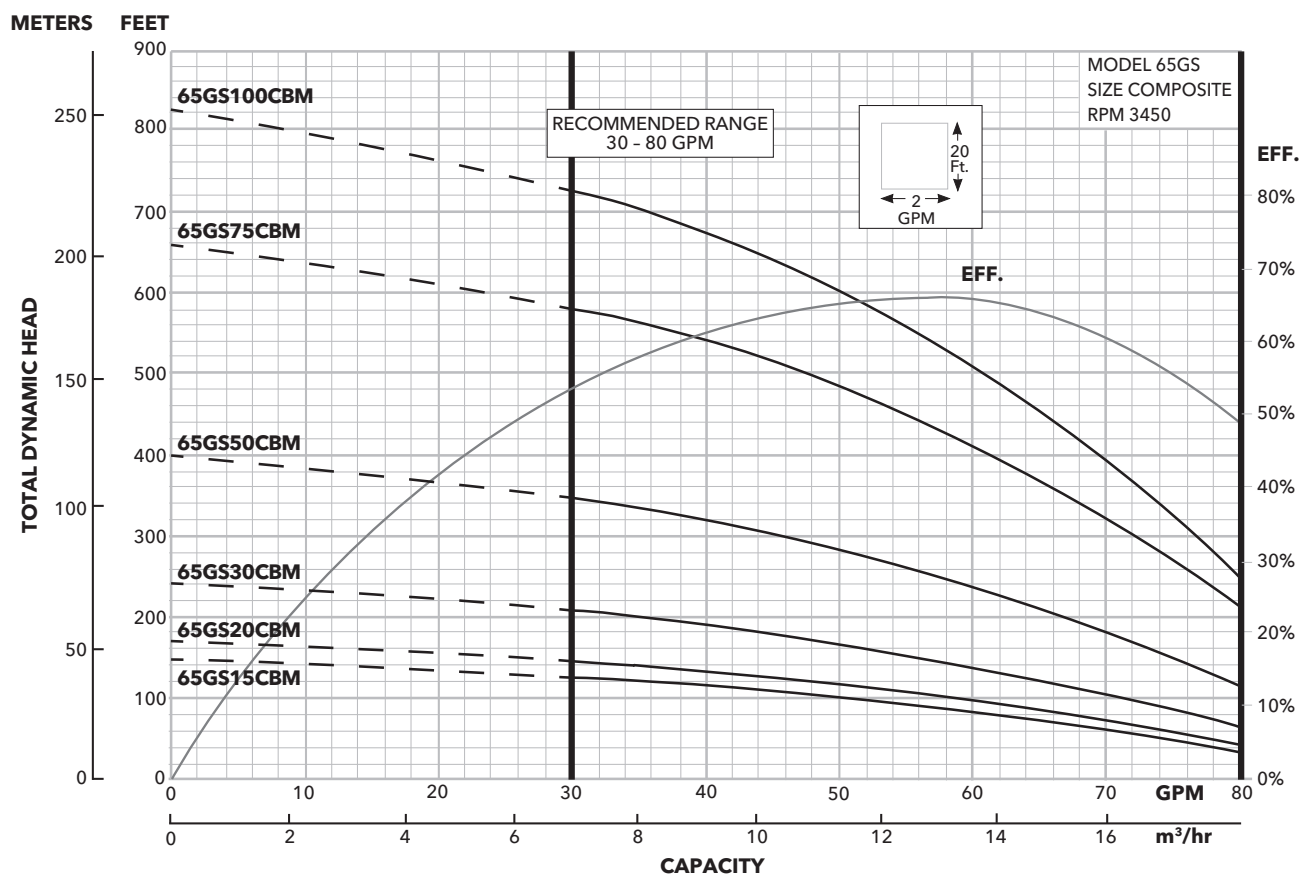

85GSCBM curve

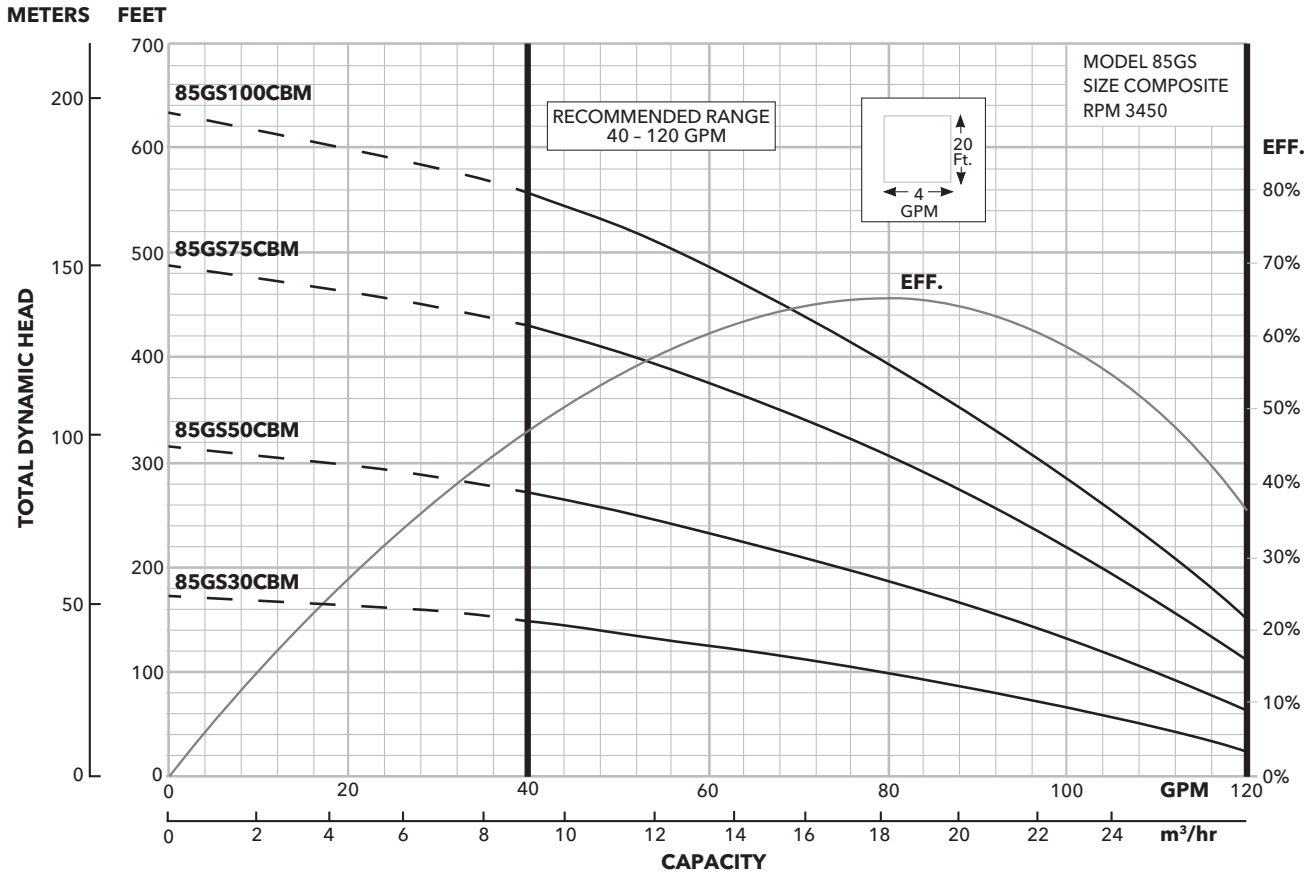

Xylem Inc. Phone: (866) 325-4210
 2881 East Bayard Street Ext., Fax: (888) 322-5877
 Suite A www.xylem.com/goulds
 Seneca Falls, NY 13148

Subject to change without notice. All information presented herein is believed reliable and in accordance with accepted engineering practices. Xylem makes no warranties as to the completeness of this information. Users are responsible for evaluating individual product suitability for specific applications. Xylem assumes no liability whatsoever for any special, indirect or consequential damages arising from the sale, resale or misuse of its products.

© 2025 Xylem is a registered trademark of Xylem Inc. or one of its subsidiaries. Goulds is a registered trademark of ITT Manufacturing Enterprises LLC and is used under license. All other trademarks or registered trademarks are the property of their respective owners.

