



# GWP Series

ASSEMBLED WASTEWATER PACKAGES

**DESCRIPTION**

The GWP Basin series is fully assembled at the factory for simplified installation. The structural foam cover is strong and corrosion resistant. Vent grommets for both 2" and 3" vents are provided, adding system flexibility and reduced inventory. The GWP features a thermoplastic 4" uniseal inlet grommet. Factory preset mechanical float switch for dependable automatic operation. The basin torque stop insert stabilizes the pump during startup. Schedule 40, 2" PVC discharge pipe with 1/8" bleed hole is factory installed.

**FEATURES**

**Choice of Pumps**

- PV Vortex
- PS Non-clog
- WW05 Vortex

**Choice of Basins**

- Ribbed 23x30 Polyethylene Basin
- Roll Top 18x30 Polyethylene Basin

**Choice of Swing Type 2" Check Valve**

- A9-2PH rubber sleeve type
- A9-2P compression type

**SPECIFICATIONS**

**23 x 30 – Basin: Ribbed polyethylene basin**

- Usable capacity: 24.8 gallons
- Dimensions: 23" w x 30" h
- Inlet: 4" inlet hub

**18 x 30 – Basin: Roll top polyethylene basin**

- Usable capacity: 14 gallons
- Dimensions: 18" w x 30" h
- Inlet: 4" inlet grommet

**APPLICATIONS**

- Basement bathrooms
- Home remodels
- Sewage lift stations
- Areas where waste must be removed quickly, quietly, and efficiently

**PACKAGE WITH 18X30 BASIN**

Package Order Number	Pump	Volts	Basin	Cover	Check Valve	Discharge Pipe
GWP2211	PS51P1F	115	Roll Top Polyethylene 18" Diameter x 30" High with 4" Inlet Grommet and Pump Torque Stop Insert	18" Structural Foam Cover with Bolts, Sealing Tape and (2) 2" and(1) 3" Vent and Discharge Grommets	A9-2P 2" Compression Type	2" Diameter x 30" Long Schedule 40 PVC Discharge Pipe
GWP2241	PV51P1F					
GWP2231	WW0511AC					
GWP2111	PS51P1F					
GWP2141	PV51P1F					
GWP2131	WW0511AC				A9-2PH 2"Rubber Sleeve Type	
GWP2142	PV52P1F	230				

**PACKAGE WITH 23X30 BASIN**

Package Order Number	Pump	Volts	Basin	Cover	Check Valve	Discharge Pipe
GWP1211	PS51P1F	115	Ribbed Polyethylene 23" Diameter x 30" High with 4" Slip Type Inlet Hub and Pump Torque Stop Insert	18" Structural Foam Cover with Bolts, Sealing Tape and (2) 2" and(1) 3" Vent and Discharge Grommets	A9-2P 2" Compression Type	2"Diameter x 30" Long Schedule 40 PVC Discharge Pipe
GWP1241	PV51P1F					
GWP1231	WW0511AC					
GWP1111	PS51P1F					
GWP1141	PV51P1F					
GWP1131	WW0511AC				A9-2PH 2"Rubber Sleeve Type	
GWP1142	PV52P1F	230				

**PUMP INFORMATION**

Pump	HP	Volts	Max Amps	Min Cicrcuit Breaker	Phase	Impeller Type	Float	Power Cord Length	Discharge Connec-tion	Max Solids
PS51P1F	0.5	115	13	20	1	Semi-Open	Piggyback Wide Angle	20'	2"	2"
PV51P1F						Vortex				
WW0511AC		Vortex								
PV52P1F		Vortex								
		230	6.5	15						

<sup>1</sup> Information on individual basin components for "replacement parts" may be found in the Basin Section, kit numbers CWK11, CWK12, CWK21, CWK22 and CWK23.

<sup>2</sup> Additional pump information may be found on the pump bulletin

**NOMENCLATURE**

Character	Code	
1-3	GWP	Assembled Vortex Wastewater Package
4 and 5	11	23" x 30" Ribbed basin with A9-2PH check valve
	12	23" x 30" Ribbed basin with A9-2P check valve
	21	18" x 30" Poly basin with A9-2PH check valve
	22	18" x 30" Poly basin with A9-2P check valve
6 and 7	11	PS51P1F
	41	PV51P1F
	31	WW0511AC
	42	PV52P1F
		20' Piggyback wide angle

**DIMENSIONS**

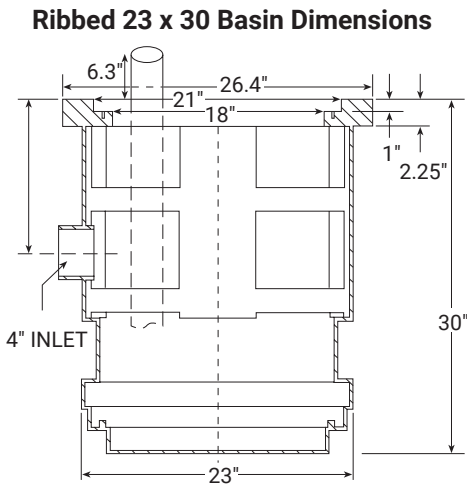

For additional basin kit data, see basin bulletins BCPCWK11.

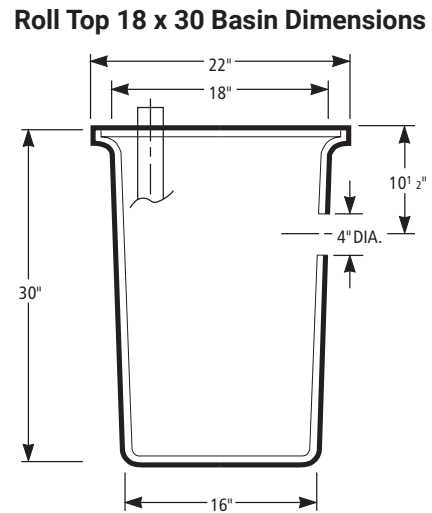

For additional basin kit data, see basin bulletins BCPCWK21.

# Xylem |'zīləm|

- 1) The tissue in plants that brings water upward from the roots;
- 2) a leading global water technology company.

We're a global team unified in a common purpose: creating advanced technology solutions to the world's water challenges. Developing new technologies that will improve the way water is used, conserved, and re-used in the future is central to our work. Our products and services move, treat, analyze, monitor and return water to the environment, in public utility, industrial, residential and commercial building services settings. Xylem also provides a leading portfolio of smart metering, network technologies and advanced analytics solutions for water, electric and gas utilities. In more than 150 countries, we have strong, long-standing relationships with customers who know us for our powerful combination of leading product brands and applications expertise with a strong focus on developing comprehensive, sustainable solutions.

**For more information on how Xylem can help you, go to [www.xylem.com](http://www.xylem.com)**

---

Xylem Inc.  
2881 East Bayard Street Ext.,  
Suite A  
Seneca Falls, NY 13148

Phone: (866) 325-4210  
Fax: (888) 322-5877  
[www.xylem.com/goulds](http://www.xylem.com/goulds)

Subject to change without notice. All information presented herein is believed reliable and in accordance with accepted engineering practices. Xylem makes no warranties as to the completeness of this information. Users are responsible for evaluating individual product suitability for specific applications. Xylem assumes no liability whatsoever for any special, indirect or consequential damages arising from the sale, resale or misuse of its products.

© 2025 Xylem is a registered trademark of Xylem Inc. or one of its subsidiaries. Goulds is a registered trademark of ITT Manufacturing Enterprises LLC and is used under license. All other trademarks or registered trademarks are property of their respective owners.

GWT-GWPSERTB-4000024 R1 1/2025

**xylem**  
Let's Solve Water