



HYPACK
a xylem brand

Common HYPACK® Drivers

Interfacing Notes

56 Bradley St.
Middletown, CT 06457
USA
www.hypack.com

Phone: 1-860-635-1500
Fax: 1-860-635-1522
Tech. Support: help@hypack.com

Table of Contents

Positioning Devices

I.	GPS.dll	- - - - -	1-12
II.	GPS_Sync_Only.dll	- - - - -	1-29
III.	F180.dll	- - - - -	1-32
IV.	GenOffset.dll	- - - - -	1-36
V.	Hydroid.dll	- - - - -	1-42
VI.	Ixsea_USBL.dll	- - - - -	1-44
VII.	Mavlink.dll	- - - - -	1-47
VIII.	Novatel.dll	- - - - -	1-49
IX.	NTRIP.dll	- - - - -	1-55
X.	Phins.dll	- - - - -	1-58
XI.	POS MV.dll	- - - - -	1-61
XII.	SBG.dll	- - - - -	1-68
XIII.	SSB.dll	- - - - -	1-73
XIV.	Towfish.dll	- - - - -	1-75
XV.	Towfish_Simple.dll	- - - - -	1-84
XVI.	TrackMan.dll	- - - - -	1-88
XVII.	Trackp.dll	- - - - -	1-91

Echosounders

I.	Bathy500.dll	- - - - -	2-103
II.	Bathy1500.dll	- - - - -	2-105
III.	CeeducerPro.dll	- - - - -	2-109
IV.	Ceescope.dll	- - - - -	2-112
V.	Deso1517gldd.dll	- - - - -	2-116
VI.	Deso17.dll	- - - - -	2-119
VII.	Deso25.dll	- - - - -	2-121
VIII.	Dtrace.dll	- - - - -	2-124
IX.	EA300.dll	- - - - -	2-126
X.	EA500.dll	- - - - -	2-128

XI. Echologger.dll	-2-133
XII. Echotot.dll	-2-136
XIII. Echotracc.dll	-2-144
XIV. Echotraccgldd.dll	-2-147
XV. Elac4300.dll	-2-150
XVI. E-sea.dll	-2-153
XVII. Genecho.dll	-2-156
XVIII. Inn455.dll	-2-159
XIX. Inn448.dll	-2-162
XX. Knu320ms.dll	-2-165
XXI. KongsbergHPR410.dll	-2-167
XXII. KongsbergNetwork.dll	-2-169
XXIII. Nautronix.dll	-2-171
XXIV. Navisound210.dll	-2-173
XXV. Navisound515.dll	-2-175
XXVI. OdomCV3.dll	-2-182
XXVII. RossSmart.dll	-2-187
XXVIII. SmartSwp.dll	-2-190
XXIX. Sonarmite.dll	-2-194
XXX. Sonarlite.dll	-2-196
XXXI. Sontek_M9.dll	-2-197
XXXII. SubBot.dll	-2-205
XXXIII. Syqwest.dll	-2-217

Motion Sensors

I. GenHPR.dll	-3-223
II. HHPR.dll	-3-225
III. Octans.dll	-3-227
IV. TSS320.dll	-3-228

Heading Devices

Table of Contents

I. ADGC.dll - - - - - 4-235
II. SGBrown.dll - - - - - 4-236

Tide Gauges

I. Htg5000.dll - - - - - 5-240
II. TideDR.dll - - - - - 5-242

DREDGEPACK® Drivers

I. A2tsatt.dll - - - - - 6-258
II. Bucket.dll - - - - - 6-261
III. Crane.dll - - - - - 6-267
IV. Crane 2.dll - - - - - 6-269
V. Cutter.dll - - - - - 6-275
VI. Excavator.dll - - - - - 6-280
VII. HD25A.dll - - - - - 6-296
VIII. InnerspaceBubbler.dll - - - - - 6-299
IX. LCI90cs.dll - - - - - 6-301
X. SwingInd.dll - - - - - 6-303
XI. Vulcan.dll - - - - - 6-305

Camera Drivers

I. CanonIntf.dll - - - - - 7-4
II. FLIRThermal.dll - - - - - 7-8
III. How to Connect - - - - - 7-9
IV. Hardware Configuration - - - - - 7-12
V. Android/iOS App Set up - - - - - 7-12
VI. Running in SURVEY - - - - - 7-14
VII. Result - - - - - 7-14
VIII. GoPro_Capture.dll - - - - - 7-16

Drivers with Other Functions

I. 3DLRInd.dll - - - - - 8-20

Table of Contents

II.	ADCP.dll - - - - -	8-23
III.	AIS.dll - - - - -	8-27
IV.	Autolines.dll - - - - -	8-29
V.	AutoPilot.dll - - - - -	8-31
VI.	Capture.dll - - - - -	8-36
VII.	Coverage.dll - - - - -	8-38
VIII.	Delph.dll - - - - -	8-41
IX.	Diver6.dll - - - - -	8-43
X.	DraftTable.dll - - - - -	8-46
XI.	Eelgrass.dll - - - - -	8-50
XII.	GenDevAll.dll - - - - -	8-52
XIII.	GenDevParse.dll - - - - -	8-57
XIV.	GenEvent.dll - - - - -	8-60
XV.	GenLaser.dll - - - - -	8-63
XVI.	Hysweep.dll - - - - -	8-64
XVII.	Hysweep_Playback.dll - - - - -	8-66
XVIII.	LCD3.dll - - - - -	8-68
XIX.	LCD4.dll - - - - -	8-70
XX.	LineOffset.dll - - - - -	8-71
XXI.	LptEvt.dll - - - - -	8-73
XXII.	LRIND.dll - - - - -	8-77
XXIII.	KP.dll - - - - -	8-79
XXIV.	M3.dll - - - - -	8-81
XXV.	MVP.dll - - - - -	8-83
XXVI.	NMEA.dll - - - - -	8-86
XXVII.	NMEAOutput.dll - - - - -	8-90
XXVIII.	NOAACo-ops.dll - - - - -	8-93
XXIX.	NoaaWeather.dll - - - - -	8-96
XXX.	Playback.dll - - - - -	8-98

Table of Contents

XXXI.SeabedID.dll - - - - -	8-100
XXXII.Sim32.dll - - - - -	8-124
XXXIII.Sonarwiz.dll - - - - -	8-126
XXXIV.WindDriver.dll - - - - -	8-128

Positioning Devices

•

GPS stands for the Global Positioning System. This is a system of 24 satellites, which provides accurate positioning services twenty-four hours per day. GPS equipment can “trilaterate” a position for the GPS antenna using the distances between four or more satellites, and the exact position of each satellite at the time of measurement. The accuracy of the position depends on several factors, the most important being the mode of positioning.

GPS Positioning Modes

Your GPS can be operated in different modes. The mode determines the accuracy of the output.

TABLE 1. GPS - Modes and Accuracy

Mode	Accuracy (Approximate)
Stand Alone (No Differential)	5m-10m
Differential	1m-5m
Real Time Kinematic	5cm-10cm

- **Stand Alone** is GPS at its most basic. All you need is a GPS receiver on his boat. Since the general public was given use of the "P-Code" (previously only available to the U.S. Department of Defense), you can resolve a position to within 10m. Stand-alone GPS should only be used in hydrographic surveying if the errors represent less than 0.1mm on your plotting sheet. For example, if you are surveying at 1:100,000 a GPS positioning error of 100m would represent 0.1mm on your plotting sheet.
- **Differential mode** (DGPS) uses error corrections, generated by a shore-based station over a known point to improve accuracy to less than 5 meters. By placing a GPS unit on a known point, the receiver can compare what the observed distances are to what the calculated distances are for each satellite. The difference between these two distances can be attributed to atmospheric conditions, dithering, spoofing or pseudo-range ambiguities. (Ha! That's a good one! Confuse them with tech-talk.) The shore-based GPS unit can calculate corrections for each satellite and transmit them to the ship-based GPS unit via a radio telemetry link. These corrections are called RTCM. The ship-based unit then "corrects" the observed distances from each satellite and computes an improved position. The U.S. Government, and many other nations, have now established government –run differential beacons that provide differential correction service anywhere on the nation's waterways. By purchase of a GPS-Beacon system, you do not have to establish your own shore station. The GPS-Beacon system automatically determines the best (or closest) station to use. Accuracy for GPS systems depends on the quality of the set, the number of satellites being tracked and the geometry of the satellites being tracked.

-
- **Real Time Kinematic (RTK)** uses more information to determine the exact wavelength count between each satellite. By using an RTK-capable base station with an RTK-capable ship station, you can position the GPS antenna to within 5 to 10 cm. The main drawback to RTK systems is that you must invest in and maintain their own base station. The base station must also be within several kilometers (say, 10km for argument's sake) of the ship and a "high end" radio telemetry link must be used to transfer higher data rates than normal GPS traffic. Using the precise positioning capability of RTK, it is possible to use the GPS antenna to determine water level readings. This allows you to work without having to use traditional tidal corrections.

GPS Positions

A GPS system provides constant updates from the ship's GPS antenna. This information is normally given as **Latitude, Longitude and Ellipsoid Height**, and is based upon WGS-84. There are a few systems that can be programmed to provide Latitude, Longitude and Ellipsoid Height on another datum. There are also a few GPS systems which can be programmed to provide X-Y coordinate information on a user specified projection.

- **If your GPS provides WGS-84 based information and you are surveying on a datum other than WGS-84** (or other than GRS-80 [NAD-83]), you need to tell the SURVEY program it has to perform a datum transformation.
- **If your GPS provides a position based on the datum on which you are surveying**, whether it is WGS-84 or any other ellipsoid, you do not need to perform a datum transformation. All of the Datum Transformation parameters should be set to zero.
- **If your GPS provides an X-Y coordinate on your projection**, all you have to do is select the correct device driver to read this information. If a device does not exist, you can use the Generic XY driver and specify where in the data string the X-Y information is provided.

BEWARE!

Some GPS systems that provide latitude/longitude/ellipsoid height on datums other than WGS-84. Most of these systems are performing a datum transformation based on regression models. Depending on the number of points in your area that were used to create the model (something you won't know), the accuracy of the calculations may vary. The only way to test it is to take your GPS system over a known point in your area and monitor the position for a couple of hours.

There are also GPS systems that provide you elevation in Mean Sea Level. These systems also use a regression model to translate from Ellipsoid Height to Mean Sea Level. In the documentation of

some GPS equipment, they say Mean Sea Level, when they should be saying Ellipsoid Height.

GPS Messages

Most GPS systems can be configured to output NMEA messages. NMEA is a standard that defines how information is to be exchanged by different types of equipment. Although many manufacturers have "bent" the standard, most NMEA devices can communicate with HYPACK® by using the GPS driver using the following messages:

Position:	
GGA	Position/Status Information
GLL	Position Information (Lat/Long/Time only)
GGK	Early kinematic message
PNTL,GGK	Kinematic and quality information.
GNS	Position and status information
LLQ	Leica kinematic and status information

Heading:	
VTG	Velocity and heading
HDT	True heading information
RMC	Speed and heading information
GST	Heading information

Miscellaneous:	
GSA	GPS DOP and active satellites.
GSV	Satellites in view
PTNL,QA	Quality message for the PTNL,GGA
PTNLR,ATT	Attitude information
PSER,ATT	

For all GPS applications, we prefer to receive the GGA and the VTG messages. They should be selected in the Advanced window of the GPS Driver Setup dialog.

The GGA message provides:

- UTC Time Information
- Latitude
- Longitude
- Ellipsoid Height
- PDOP\Number of Satellites
- GPS Mode (Differential vs. Stand-alone vs. Kinematic)

•

*Time Tagging
GPS Information*

Some lower end equipment outputs the GLL message, instead of the GGA. This provides only the UTC time, latitude and longitude information. The main drawback is that this equipment does not notify the SURVEY program when the mode changes from Differential to Non-Differential.

The VTG sentence provides:

- Speed Information
- Course Made Good Information

To correctly correlate positions with other data, it is essential to determine the precise time of the GPS measurement.

SURVEY and DREDGEPACK® use a proprietary clock model called Veritime. Veritime is initially set to the Windows® clock time, but the two clocks slowly drift apart. In a simple hardware configuration (eg. a GPS and single beam echosounder), all time tags are assigned based on the same standard: the Veritime clock.

IMPORTANT: *All devices must use the same time basis*—the computer Veritime or UTC time. If any device sends UTC time-stamped data, you must synchronize your computer clock with UTC time using the 1PPS box or the NMEA ZDA message.

If you synchronize the clock, HYPACK® adjusts the Veritime clock speed to match the UTC time based on the time in the ZDA message from the GPS.

NOTE: You should run SURVEY or DREDGEPACK® for two minutes before collecting data to allow the Veritime clock to synchronize with UTC time.

BEWARE! Update settings *on your GPS* of faster than 1000 msec (or 1 Hz) when you are using the Sync. Clock feature may result in significant drift between the computer clock and GPS time.

NOTE: This is different than the update frequency of the driver.

The following table presents the three techniques used in HYPACK® to determine the time of measurement. Each has its advantages and drawbacks.

TABLE 2. Time Tagging Options

Method	Advantages	Disadvantages
Apply a Fixed Latency Time.	<ul style="list-style-type: none"> Simple. It does not require any special cable and allows you to operate on local time. 	<ul style="list-style-type: none"> GPS latency can vary, depending on the type of receiver, the number of satellites and the geometry of the satellites.
Use the NMEA ZDA message to synchronize the computer clock.	<ul style="list-style-type: none"> Simple. It does not require any special box or cable. Eliminates drift between the GPS and computer time. Accuracy to within 1 msec. 98% of the time. 	<ul style="list-style-type: none"> The \$ of the \$GPZDA message must be transmitted at the referenced UTC time. Some GPS units do not have ZDA capability.
Monitor the 1PPS Output of the GPS	<ul style="list-style-type: none"> Provides a time tag of 1PPS times accurate in HYPACK® to within 100 microsec. with standard deviation of 2 microsec. 	<ul style="list-style-type: none"> Requires a special hardware box and cable. GPS manufacturers differ over the timing of the 1PPS pulse.

Time Tagging Using the 1PPS Pulse: If you include data from another computer with time synchronized data (such as the POS MV or Geoswath), your survey computer must also be synchronized in order to accurately match the data. In HYPACK®, we synchronize to UTC time.

Many GPS units can output a 1PPS (pulse per second) signal that is synchronized with the measurement phase. By using a 1PPS box to synchronize the computer clock to UTC time indicated in the ZDA message, HYPACK® can achieve time tag precision to within 100 microseconds of the 1PPS pulse (the most accurate indicator of the UTC time) with a standard deviation of 2 microseconds.

The HYPACK® SURVEY program uses the 1PPS box to monitor the CTS line of the GPS serial port. Every time it changes state (from 0 VDC or from 5 VDC to 0 VDC), it takes a time tag from the Veritime computer clock (corrected with the Windows® time zone offset). If a latency value has been entered, it also offsets the time tag by the value in the latency offset. The next message arriving from the GPS then receives that time tag.

- **In the HARDWARE System tab**, select the GPS driver under the Synchronize Computer Clock option.
- **In the General tab** of the GPS driver setup, select the **Use PPS Box for Timing** option.
- **Graphing the Synchronization Values** is optional, but the displays will alert you if the synchronization has gone awry.

FIGURE 1. Synchronizing the Clock to the GPS

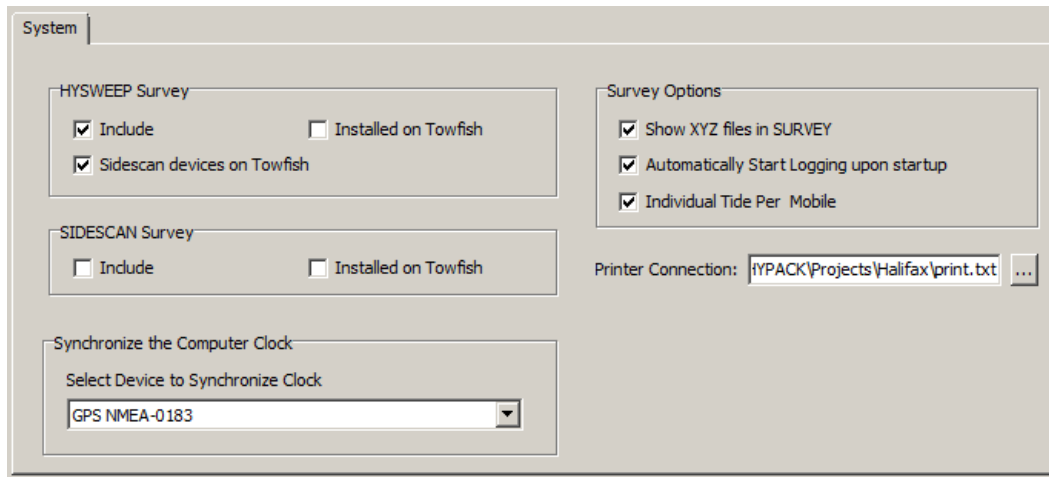
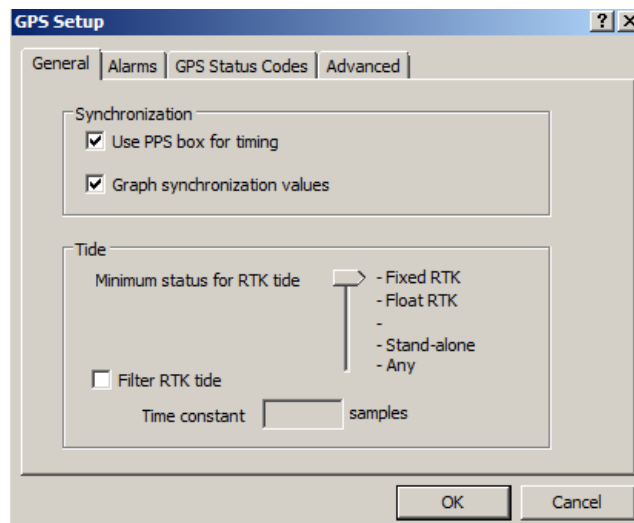

FIGURE 2. Instructing the SURVEY Program to use the 1PPS Output for Time Tagging in the GPS.dll Setup.



You can use the ZDA TEST to verify the synchronization and view statistics regarding various factors affecting the level of synchronization.

Time Tagging GPS Information Using the NMEA ZDA Message: Using the arrival time of the ZDA message, HYPACK® eliminates clock drift between the GPS and the computer clock and generates time tags to within 1 millisecond accuracy 98% of the time.

This is only important when using devices that output time-tagged information. In these cases, the device must also be synchronized to the UTC time in the ZDA message and we maintain the time the device assigned to the data because it is more closely correlated to

the data than if we were to assign a time tag when the survey computer receives the data.

NOTE: This works for all GPS devices, whether they are RTK-capable or Differential.

Many GPS units can output a ZDA message, which contains only the UTC time, at the UTC time tic. As soon as the message is received, the SURVEY program uses the local time offset from the Windows® registry and resets the computer clock to the local time. All of the time tagging for other devices (echosounder, gyro, etc.) will now be based on the computer clock. You should let SURVEY run for at least two minutes to begin the process. From then on, the SURVEY program uses the UTC time contained in the GGA message as the time tag for the GPS position.

BEWARE!

Update rates for ZDA messages, *set in the GPS*, should be no faster than 1000 msec (or 1 Hz) when you are using the Sync. Clock feature. Faster update rates may result in significant drift between the computer clock and GPS time.

- In the HARDWARE System tab, select the GPS driver under the **Synchronize Computer Clock** option.
- In the General tab of the GPS driver setup, *clear* the **Use PPS Box for Timing** option.
- **Graphing the Synchronization Values** is optional, but the displays will alert you if the synchronization has gone awry.

Applying a Fixed Latency Time: Enter a latency value in the **Offsets for the GPS device**. When a measurement is received from the GPS, the computer takes the current computer clock time and subtracts the latency value to determine the time of the measurement.

For example, if the latency is 0.5 seconds. When the computer receives a GPS message, it gets a time tag when it receives the first character. It would then subtract the 0.5 seconds from the time tag to obtain the final time of measurement.

FIGURE 3. *Specifying the Latency for a GPS device*

The screenshot shows a software interface with two columns of input fields. The left column contains 'Starboard' (0.000), 'Forward' (0.000), and 'Vertical' (-6.00). The right column contains 'Yaw' (0.00), 'Pitch' (0.00), and 'Roll' (0.00). Below these is a section titled 'Device Latency' with a label 'Enter the Latency Time (Positive) in Seconds' and a text box containing '0.12'.

To obtain a latency value, perform a single beam latency test or, if you also have a multibeam system, a patch test. This determines the combined latency between the GPS and your echosounder.

BEWARE!

There is some variation in GPS latency. For most newer equipment, we have performed tests that show the standard deviation of latency to be within 0.050 seconds for most GPS receivers. The main problem occurs with RTK units. There are some RTK units that take up to two seconds to output a position. These sets have major variation in latency and this method should be used at survey scales of 1:25,000 or higher.

NMEA Records in RAW Data Files: The SURVEY program can store the following record types for NMEA GPS equipment in the SURVEY programs.

TABLE 3. Raw Format

Message (Tag) Type	Information
POS (Position data)	Device number Time tag Easting Northing
RAW (Raw data)	Device number Time tag WGS-84 latitude WGS-84 longitude WGS-84 ellipsoid height
QUA (Quality data)	Device number Time tag PDOP/HDOP Number of satellites Quality information (if available).
MSG (Single Beam) RMB (Multibeam) RSS (SideScan)	Data string as it is read from the device.

The **POS**, **RAW** and **QUA** records are automatically recorded at the specified logging rate.

This provides flexibility should the need to re-compute positions arise, due to a different projection or ellipsoid or transformation, after the data has been collected.

Confirming Time Synchronization with the ZDA Test: Using the arrival time of the ZDA message, HYPACK® eliminates clock drift between the GPS and the computer clock and generates time tags to within 1 millisecond accuracy 98% of the time.

This is only important when using devices that output time-tagged information. In these cases, the device must also be synchronized to the UTC time in the ZDA message and we maintain the time the device assigned to the data because it is more closely correlated to the data than if we were to assign a time tag when the survey computer receives the data.

NOTE: This works for all GPS devices, whether they are RTK-capable or Differential.

Many GPS units can output a ZDA message, which contains only the UTC time, at the UTC time tic. As soon as the message is received, the SURVEY program uses the local time offset from the Windows® registry and resets the computer clock to the local time. All of the time tagging for other devices (echosounder, gyro, etc.) will now be based on the computer clock. You should let SURVEY run for at least two minutes to begin the process. From then on, the SURVEY program uses the UTC time contained in the GGA message as the time tag for the GPS position.

BEWARE!

Update rates for ZDA messages, *set in the GPS*, should be no faster than 1000 msec (or 1 Hz) when you are using the Sync. Clock feature. Faster update rates may result in significant drift between the computer clock and GPS time.

- In the HARDWARE System tab, select the GPS driver under the **Synchronize Computer Clock** option.
- In the General tab of the GPS driver setup, *clear* the **Use PPS Box for Timing** option.
- **Graphing the Synchronization Values** is optional, but the displays will alert you if the synchronization has gone awry.

GPS.DLL

Version Number: 17.0.5

Device Name: GPS with NMEA 0183 output

DEVICE SETUP

Position stores position data from this device.

Depth is typically unused by GPS devices. However, it is used in conjunction with the 'Record Tide as Depth' option to, for example, record waterfront depths using land vehicles.

Use for matrix update: Color-codes a matrix based on the data received from this device when recording tide as depths.

Heading tells the SURVEY or DREDGEPACK® program to use the Course Made Good from the VTG, RMC or HDT message for the orientation of the vessel.

BEWARE!

If you are using a gyro for heading, you should not select heading for your GPS. If both were selected for heading, the SURVEY or DREDGEPACK® program would switch between gyro and GPS orientation as each device updates and you would see the vessel in your SURVEY Map window twitch at each update. This is because it is unlikely that the two heading values will be exactly the same.

The **Speed** box tells the SURVEY or DREDGEPACK® program to use the speed information from the VTG message for the vessel speed.

Tip:

The GPS speed is much smoother and more accurate than the speed the SURVEY program will calculate. We recommend that you use the speed from your GPS antenna.

The **Tide** box is available for RTK GPS devices only when using the GPS device driver. If you check this box, the program will create real-time water level corrections at each GPS position update, based on the separation between the ellipsoid height and chart datum and the separation between the GPS antenna and the echosounder transducer.

Tip:

If you are using a DGPS, we recommend that you use a tide gauge or create tide correction files to account for changing water levels.

The **Raw Data**, and **Quality Data** are automatically recorded. This enables you to re-compute positions in post-processing to correct bad datum transformation parameters entered during the data collection.

Raw Data records:

- WGS-84 latitude (decimal degrees)
- WGS-84 longitude (decimal degrees)
- WGS-84 ellipsoid height
- UTC time

Quality Data records:

- Device Number
- Time Tag
- WGS-84 PDOP/HDOP
- Number of Satellites
- GPS Mode
- Quality Information

TABLE 1. RAW Data Information

Format	RAW dn t n lat long alt utc	
Where	dn	device number
	t	time tag (seconds past midnight)
	n	number of values to follow
	lat	raw latitude X 100
	long	raw longitude X 100
	alt	antenna altitude above ellipsoid (meters)
	utc	GPS time
Sample Line	RAW 0 33643.186 4 442442.89400 -831890.22200 177.86000 132459.00000	

TABLE 2. Position Quality Information

Format	QUA dn t n m h sat mode	
Where	dn	device number
	t	time tag (seconds past midnight)
	n	number of values to follow
	m	10 minus HDOP
	h	HDOP
	sat	number of satellites

Format	QUADNTNMH SAT MODE	
	mode	GPS mode (NMEA 0183 standard values) 0 = fix not available or invalid 1 = Stand-alone 2 = Differential 3 = RTK Float 4 = Wide lane fixed RTK 5 = Narrow lane fixed RTK
	The following 3 values are decoded from GST message:	
	sigman	standard deviation of latitude error (meters)
	sigmae	standard deviation of longitude error (meters)
	semimaj	Standard deviation of semi-major axis of error ellipsis (meters)
	Remaining values are present only if synchronizing computer clock with GPS clock:	
	ref	reference time at last sync (milliseconds since midnight)
	var	computer clock at last sync (milliseconds since midnight)
	syna	computer clock frequency adjustment factor (microseconds per sec)
	syne	filtered synchronization error (milliseconds)
	syms	synchronization status. Binary code with the following bits (other bits are not meaningful) 1 = not in sync 2 = low accuracy synchronization 4 = high accuracy synchronization 8 = synchronization failure

Format	QUA dn t n m h sat mode							
	synb	computer clock phase adjustment status						
Sample Line	QUA 0	33643.186	4	8.000	2.000	7.000	2.000	
	QUA 0	50040.509	7	9.083	0.917	9.000	2.000	
		0.000	0.000	0.000				
	QUA 0	30285.600	13	8.700	1.300	7.000	4.000	
		0.059	0.033	0.059	30284964.000			
	30284964.000	2.584	0.028	34.000				
	26131962158.485							

Record Raw Messages: Logs the data string to the raw file as it is originally received from the device.

The GPS driver tags these strings with 'MSG' followed by the device number, time tag, and the data string from the GPS.

Record device specific messages: Logs additional data related to the device to the Raw file. Each record will be identified by a driver-specific, 3-character tag.

The GPS driver records SYN records:

TABLE 3. *Time Synchronization Status*

Format	SYN dn t n rt vt vs se fa pa								
Where	dn	device number							
	t	time tag in sec. after midnight							
	n	number of values to follow							
	rt	reference time used for last synchronization in msec past midnight							
	vt	Veritime at last synchronization in msec. past midnight							
	vs	Veritime status							
	se	Filtered Synchronization error in msec							
	fa	Frequency Adjustment factor in msec. indicates how fast or slow the computer clock is compared to reference clock. ^a							
	pa	Phase adjustment factor in microsec/sec. indicates if computer clock is advanced or retarded compared to reference clock. ^a							
Sample Line	SYN 1	29253.002	6	29253003.000	29253002.958	34.000	0.000	-22.295	2.577

a. This value varies due to the normal instability of the computer clock and the measurement noise of the VERITIME process.

DRIVER SETUP

General Tab

To access the Driver Setup dialog, click on [Setup] in the Device Setup dialog.

FIGURE 1. GPS.dll Setup - General Tab

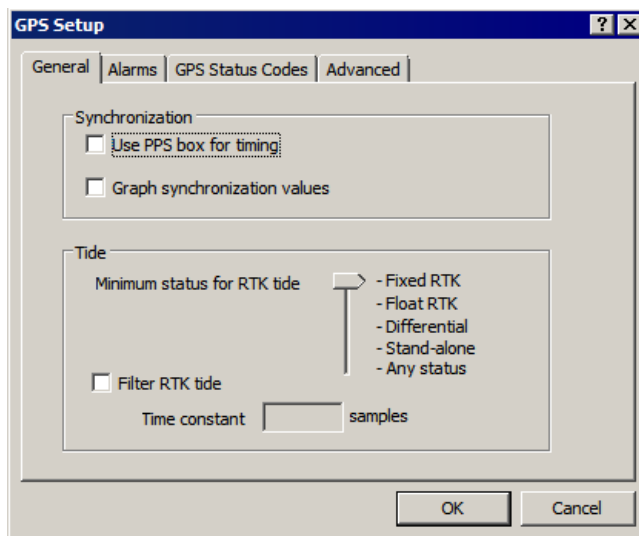

Use PPS box for timing improves the time-tagging to within 100 microseconds. This requires a special interface device available through HYPACK, and ZDA output from your GPS. You must also check the 'Sync Clock' option in the vessel's System dialog. If you are not using a PPS box, the computer time will be used.

Graph synchronization values: When checked the graph in the right hand side shows the following synchronization values:

- **Phase difference** in msec (red) is the instantaneous difference between the GPS time and Veritime time. For instance if the GPS clock is 15:32:41 and Veritime time is 15:32:42.5 the phase difference is 0.5 sec.
- **Filtered error signal** in msec (blue) - The frequency adjustment factor indicates if the computer clock is too fast or too slow compared with the GPS clock. For example, if the factor is 1 that means that computer clock would remain behind the GPS clock 1 millisecond for every second.
- **Frequency adjustment factor** in msec/sec (green) - The filtered error signal corrects the Veritime clock if it is too fast or too slow. When it is 0 the two clocks have the same frequency (the system has found the correct value for the frequency adjustment factor).

Minimum status for RTK Tide: Uses information in the GGA or GGK strings to measure the tide. Set the slider for the minimum GPS status at which your RTK GPS will calculate tide corrections.

Filter RTK Tide compares the previous and current tide values and uses the **Filtered Time Constant** to adjust the newest tide value. These adjustments smooth out small boat movements caused by factors such as choppy waters.

You may need to experiment with this a bit to find the settings that you prefer. Three factors affect the smoothing.

- The **Signal Frequency**: The high frequency signals are affected more than the low frequency signals.
- The **Filter Time Constant** determines how much to weight (percentage) the previous tide value in your comparison. The higher the constant, the more output signal is attenuated.
- The **Update Rate of the GPS**: Fewer signals per unit of time, increases the effect of the filter.

This filtering process gives you a nice display during SURVEY but the 'Average Tide Data to Remove Heave' option, in the single beam and multibeam editing programs, is technically a better tool to use to smooth your data.

Tip:

We recommend that if you are editing using one of the HYPACK® editors, smooth your tide data using the "Average Tide Data to Remove Heave" option in the editor program. If you are exporting your raw data to be edited by another system, you may want to use this filter.

The **Alarms** and **GPS Status Codes** tabs provide settings to show alarms based on the quality information in the GGA string.

NOTE: You can also filter single beam and multibeam data based on these codes in the editor programs during post-processing.

Alarms Tab

FIGURE 2. GPS Driver Setup - Alarms Tab

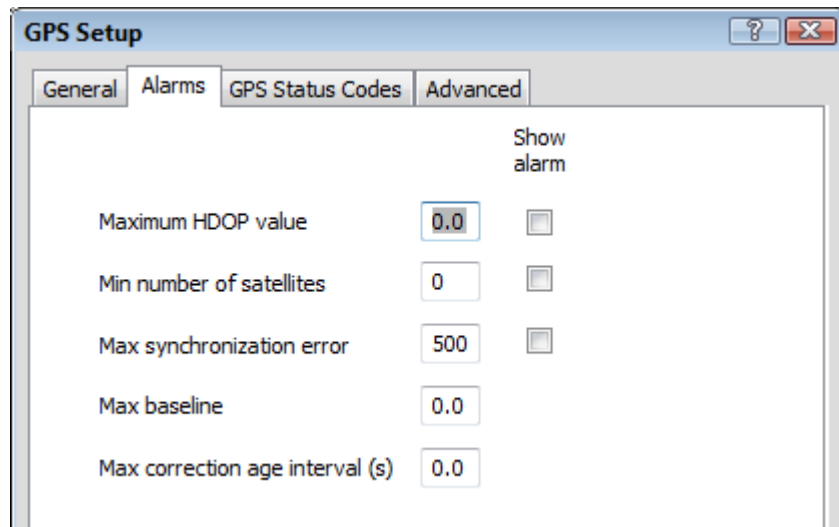

In the Alarms Tab:

1. Enter alarm conditions.
2. Check the corresponding Show Alarm box for each condition to which you want to be alerted.

TABLE 4. Alarm Conditions

Alarm Condition	Alarm Shown When
Maximum HDOP	HDOP greater than the value entered. (Recommended Value = 4)
Number of Satellites	Number of satellites less than the value entered. (Recommended Value = 5)
Maximum Synchronization Error	Difference between the computer time and GPS time at any sync. attempt is greater than the value entered. (Recommended Value = 100ms)
Maximum Baseline Error	Distance between GPSs configured for OTFGyro is greater than the distance entered. (Recommended Value = 2m for DGPS or 0.5 m for RTK.)

GPS Status Codes

FIGURE 3. GPS Driver - GPS Status Codes Tab

Codes Standard	Invalid	Stand-Alone	Differential	Float RTK	Fix RTK	Show alarm
NMEA 3.0	0	1	2	5	4	<input checked="" type="checkbox"/>
						<input type="checkbox"/>
						<input type="checkbox"/>
						<input type="checkbox"/>
						<input type="checkbox"/>

In the GPS Status Codes Tab:

1. **Select a GPS Status Code** according to your GPS output.
 - If you select either the NMEA 2.1 or NMEA 3.0 option, the status fields will automatically reflect the correct values.

TABLE 5. GPS Status Codes

GPS Mode	NMEA 2.1	NMEA 3.0
Invalid	0	0
Stand Alone	1	1
Differential	2	2
RTK Float	3	5
RTK Fixed	3	4

- If your GPS does not conform to either of these standards, select the Custom option and define your own status codes.
2. **Check the corresponding Show Alarm box for each condition to which you want to be alerted.** Alarms will show when the status codes equal the selected status. A typical RTK configuration might be to show an alarm for invalid, differential and invalid to indicate that you have lost RTK status.

Advanced

FIGURE 4. GPS Advanced Options

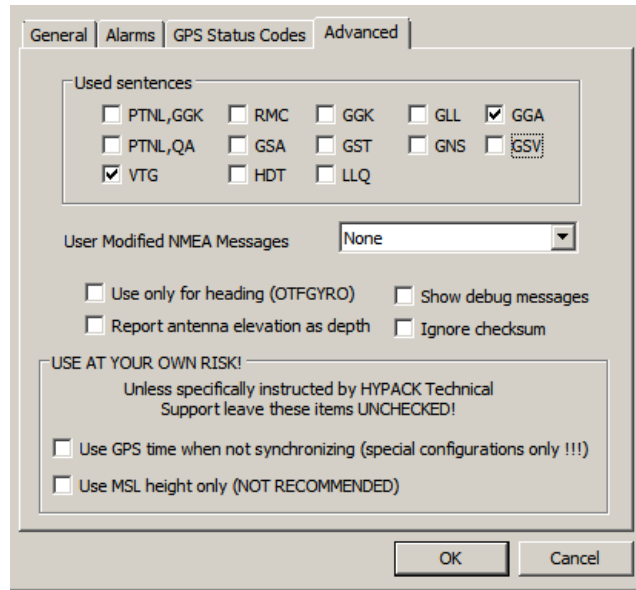

Used sentences: Instructs which strings the driver should read from your GPS output. Select *one position string* and at least one string for each of the other functions selected in the Device Setup (heading, speed, etc).

NOTE: In general we recommend that you configure the GPS receiver to output only the messages that you need and leave all the other check boxes unchecked.

Tip:

For all DGPS applications, we prefer to receive the GGA and the VTG messages.

User Modified NMEA Strings: If your system is receiving strings modified by the device manufacturer, select it from the drop-down list. The driver can then read the modified strings in addition to the strings selected from the list of standard strings. The gps.dll supports the following strings:

- Odom RTA
- Odom CV3
- CeeScope POS
- Reson RRIO
- PINGDSP
- EdgeTech (Does not output any standard NMEA strings.)
- Kongsberg

Use only for heading (On-The-Fly Gyro): Use this option in conjunction with a second GPS driver to calculate heading when using two GPS receivers that have their antennas mounted fore

and aft of the vessel. This is often the preferred method on dredges and barges.

NOTE: Configure the driver for the forward GPS with the Position function and any other functions *except heading*. Configure the driver for the aft GPS with the Heading function and check the Use This Device Only For Heading option.

Record Antenna Elevation as Depth: Used in conjunction with the Depth function to record waterfront depths using land vehicles.

Show Debug Messages shows a scrolling screen of all of this driver's activity instead of the default updating table.

Ignore Checksum: Some devices use a different checksum calculation than we do. In this case, you may get a lot of bad checksum errors when the data is good. Check this option to skip the checksum routine and assume the data is good.

Use GPS time when not synchronizing: If you use two GPS receivers and you are synchronizing your computer clock with UTC time, only the first GPS is synchronizing the computer clock with the GPS clock. However, the driver for the second GPS can safely use the UTC time tag included in the GPS message because any two GPS receivers are synchronized to UTC time. When the checkbox is checked the driver assumes that computer clock is synchronized with the GPS clock and records position messages using the UTC time provided by the GPS receiver.

Use MSL height from GGA sentence assumes the MSL height provided by the GPS receiver is correct. If you have loaded a geoid in your geodetic parameters, it will be ignored.

OFFSETS

Starboard: Distance to the right of the origin.

Forward: Distance forward of the origin.

Height: Enter the **antenna height** *below* the static water line. In most cases, this will be a negative number. It should be positive only for users who want to reduce the GPS height to the transducer.

For RTK antennae:

- **If you are using a KTD file**, enter the height of the GPS antenna above the static water line as usual.

- **If you are working without a KTD file** enter the height of the GPS antenna minus the height of the reference ellipsoid above the chart datum as your antenna height.

Yaw, Pitch, Roll are all zero for the GPS.

Enter **latency** according to the results of your Latency or Patch Test.

BEWARE!

In most cases, this value should be a *negative* number to indicate that it is above the water line. It will only be positive to reduce the GPS height to the transducer.

DEVICE OUTPUT STRINGS

User-defined in the Driver Setup dialog and in the device itself.

IMPORTANT: If you are using RTK tide calculations, you must output a GGA string with latitude, longitude, ellipsoid height and undulation (geoid height above the WGS-84 ellipsoid).

DRIVER OUTPUT STRINGS

DEVICE WINDOW

The driver writes GPS data to a spreadsheet. If you have an RTK GPS, it includes the values used to calculate RTK tides.

FIGURE 5. Sample GPS Device Window

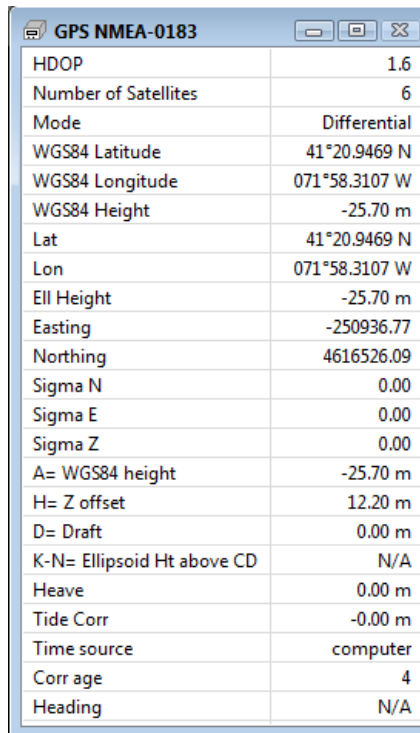

GPS NMEA-0183	
HDOP	1.6
Number of Satellites	6
Mode	Differential
WGS84 Latitude	41°20.9469 N
WGS84 Longitude	071°58.3107 W
WGS84 Height	-25.70 m
Lat	41°20.9469 N
Lon	071°58.3107 W
Ell Height	-25.70 m
Easting	-250936.77
Northing	4616526.09
Sigma N	0.00
Sigma E	0.00
Sigma Z	0.00
A= WGS84 height	-25.70 m
H= Z offset	12.20 m
D= Draft	0.00 m
K-N= Ellipsoid Ht above CD	N/A
Heave	0.00 m
Tide Corr	-0.00 m
Time source	computer
Corr age	4
Heading	N/A

SPECIAL NOTES

- The **Kinematic Tide Datum (*.KTD)** file is used for real time tide corrections when you have an RTK-capable GPS and you are surveying in an area where the height of the reference ellipsoid above the chart datum is not constant. The driver will automatically load the KTD specified in the GEODETIC PARAMETERS. It assumes the KTD values are in survey vertical units.

OPERATING WITHOUT A KTD FILE

A KTD file is only necessary if you are in an area where the separation between the reference ellipsoid and chart datum is not a constant.

You do not need a KTD file if any of the following are true:

- **You are using a geoid and the separation between the reference ellipsoid and chart datum is a constant.**
In this case, select **N** from **Geoid Model**, **K** from **User Value** and enter the **Height of the Geoid Above Chart Datum**.

FIGURE 6. GEODETIC PARAMETERS—RTK Options Where There is a Geoid and Height of the Geoid Above Chart Datum is Constant

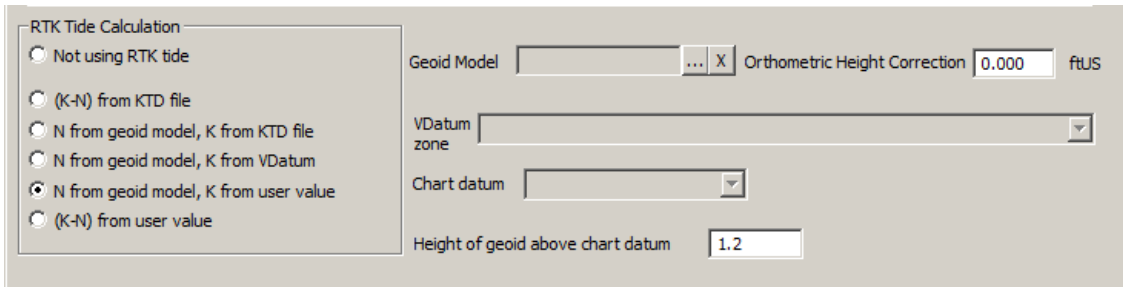

- **You are not using a geoid, but the height of the ellipsoid above chart datum is constant.** This is common when your survey area is very small. In this case, select **(K-N) from User Value** and enter the **Height of Ellipsoid Above Chart Datum**.

FIGURE 7. GEODETIC PARAMETERS—RTK Options Where There is No Geoid and Height of Ellipsoid Above Chart Datum is Constant

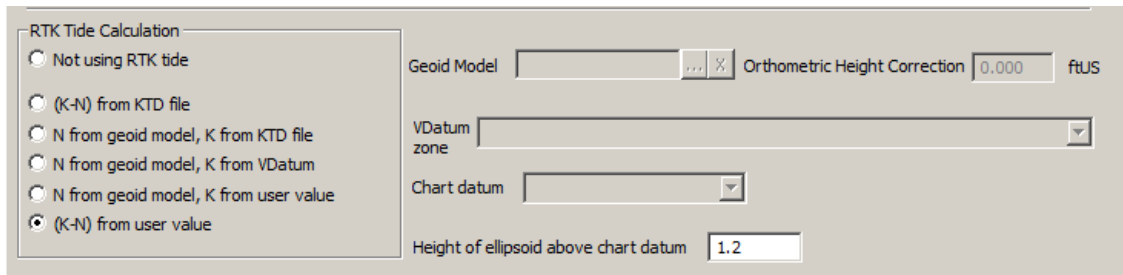

- **You are surveying in United States coastal waters.** In this case, Select **N From Geoid Model, K From VDatum**, enter your **VDatum Zone**, **chart datum** and **geoid**. You get the height of geoid above chart datum from the VDatum database.

FIGURE 8. GEODETIC PARAMETERS—RTK Options Using the VDatum Database

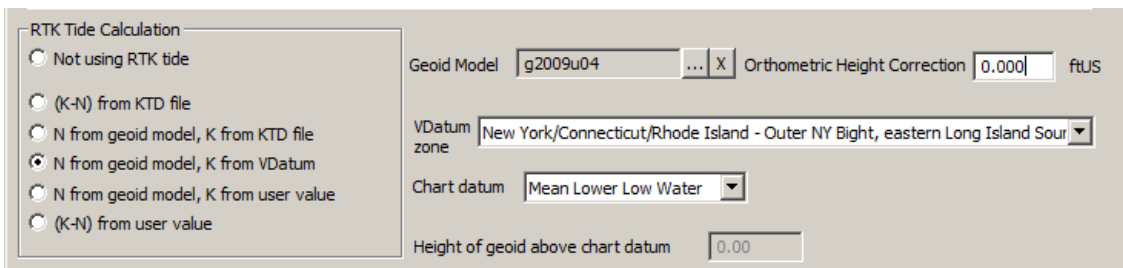

- **You are not calculating RTK tide corrections.**

FIGURE 9. GEODETIC PARAMETERS—SURVEY Does Not Calculate RTK Tides

RTK Tide Calculation

Not using RTK tide

(K-N) from KTD file

N from geoid model, K from KTD file

N from geoid model, K from VDatum

N from geoid model, K from user value

(K-N) from user value

Geoid Model ... % Orthometric Height Correction ftUS

VDatum zone

Chart datum

Height of geoid above chart datum

ALARMS

TABLE 6. GPS Alarm Messages

Alarm Text	Conditions
Invalid	If GPS code <= Invalid Code
NonDif	GPS code <=Non-dif Code
NonKin	GPS code<=Non Kin. Code
Tide	If RTK tide calculation fails.
HDOP	If HDOP limit entered in driver setup and HDOP is greater than the limit
SAT	If Number of Satellites entered in driver setup and # Satellites is less than limit set.
Sync Failed	Driver failed to sync clock. If the “sync clock on other sentences” option is not selected, the error means that the driver isn’t getting a ZDA string. If you have allowed it to try other sentences, this alarm shows when the driver has tried all 3 sentence types (ZDA, GGA, RMC) and has failed.

GPS GRAPHS IN SURVEY

In addition to the data in the GPS device window, GPS drivers provide several real-time graphical displays of data extracted from your GPS input. Each value is configured and graphed independently. You can choose to display any number of displays offered.

Most of the graphs are linear displays:

- **Number of Satellites**
- **Undulation**
- **Ellipsoidal Height**

- Sync Error
- Math
- Sky

To access the view options window for each window, right-click on the graph you wish to modify and select 'Setup'.

FIGURE 10. Sample Graph Setup Options - Ellipsoidal Height

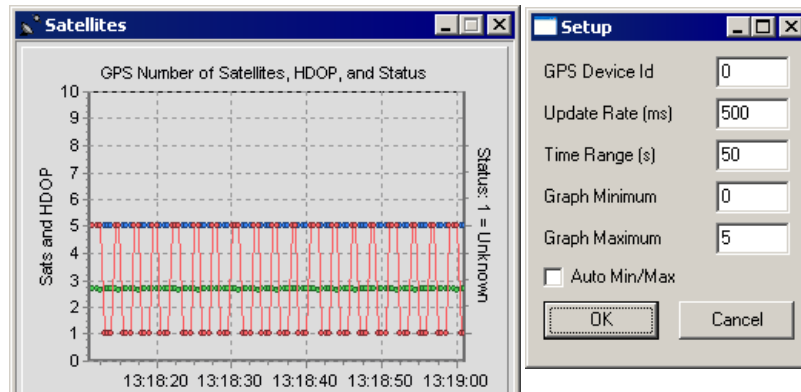

- **GPS Device ID:** Devices are numbered according to the order in which they are entered. The first device ID is '0'.
- **Update Rate of the graph** determines how frequently new data is recorded to the graph.
- The **Time Range** defines the horizontal range of the graph.
- **Graph Minimum** and **Maximum** values to define the vertical range of the graph where applicable. Check **Auto Min./Max** to let SURVEY or DREDGEPAK® adjust the range to fit the data.
- The **Ellipse Error** graph shows the error in the ellipsoid, which is calculated from data in the PTNL,QA or GST string. Select the appropriate scale factor to size the ellipse to fit the screen.

FIGURE 11. Sample Ellipse Error Graph (left) and Setup (right)

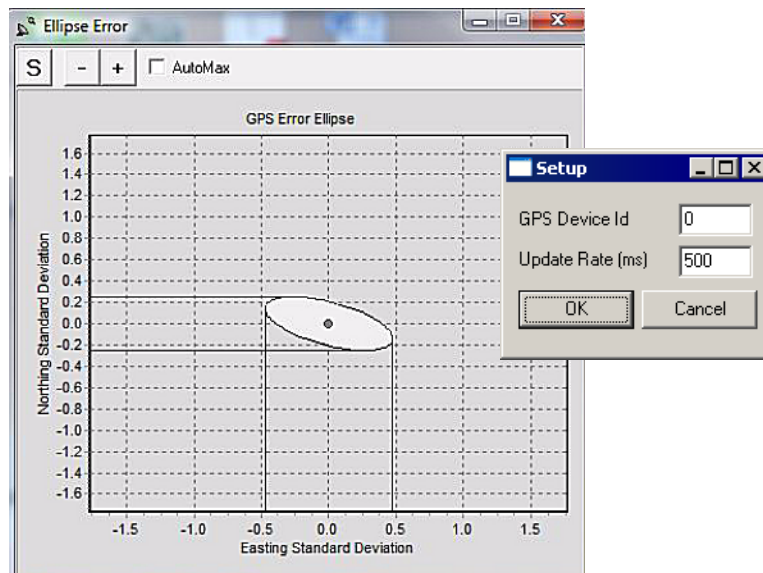

- The **Math Display** is a diagram of your vessel relative to the surfaces in your survey. It displays each value (measured and calculated) in the real-time kinematic tide calculation.

FIGURE 12. Math Display in SURVEY (left) and its setup (right)

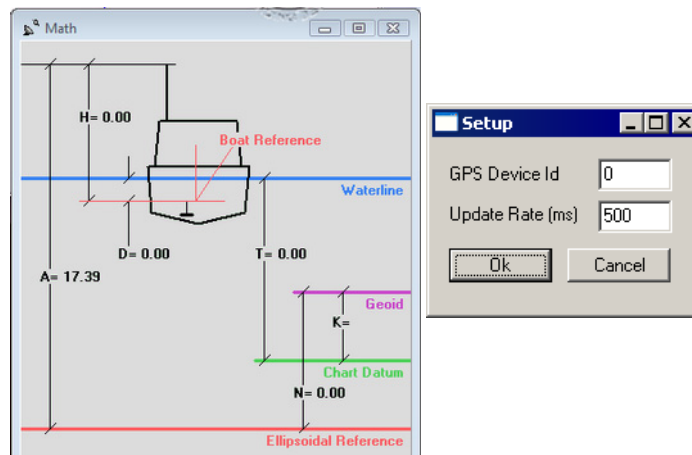

- The **Sky window** displays the position of available satellites (90 degrees is straight overhead) with their Sat ID written inside their symbol. If their signal to noise ratio is adequate (it usually is), the satellites are colored green. If the signal-to-noise ratio of a satellite is less than required, it turns them red.

NOTE: This display requires the GSV string from the GPS.

FIGURE 13. Sample GPS Sky window

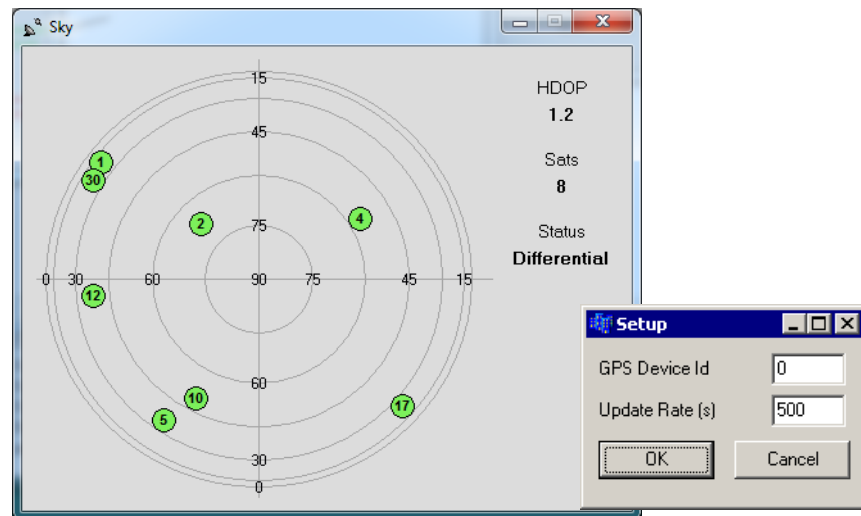

MISCELLANEOUS:

- **Ignore ZDA messages if date is missing.** (POSM/V sends ZDA messages containing only time for a few seconds after losing satellites. The driver was trying to sync on those messages and VERTIME had trouble.)
- In **Edgetech mode**, there can be RTK-related problems due to the Discover Bathy Processor module. HYPACK has confirmed that the combination of GPS.dll v. 16.1.1 and Edgetech Bathy Processor v. 66.0.1.103 works correctly.
- **Edgetech NMEA Messages:** The Edgetech JSF data stream includes NMEA messages inside the "2002" packet. The Edgetech side scan drivers for 4XXX series sonars will dump these NMEA packets to a UDP broadcast stream so that GPS.dll can parse them. HYPACK has confirmed that the combination of GPS.dll v. 16.1.1 and Edgetech Bathy Processor v. 66.0.1.103 works correctly.

NOTE: Note that this feature is side scan only. The 4600 & 6205 interferometers in HYSWEEP® mode do not support this feature. Edgetech bathymetric products have their own set of GPS-related packets.

GPS_SYNC_ONLY.DLL

Version Number: 16.0.0.1

Device Name: GPS Sync Only

The GPS_Sync_Only driver enables you to configure a GPS receiver to be used only to synchronize (sync) the computer clock to UTC time. This comes in handy with an acquisition system that broadcasts position strings via a network connection and SURVEY records the timing from that position string. Many times, additional devices interfaced in HYPACK® (sounders, and heading and MRU devices) are not providing a time-tag, and the time-tag logged is the time the computer receives the message (computer time), which may or may not match UTC time. (HYPACK® offsets to the local time zone.)

In a situation like this, you can configure the gps.dll to provide sync only, but it is not always easy to see if it is actually functioning properly. The GPS_Sync_Only driver is specifically designed to provide sync only directly from a GPS receiver.

DEVICE SETUP

Record Raw Messages: Logs the data string to the raw file as it is originally received from the device.

Record device specific messages: Logs additional data related to the device to the Raw file. Each record will be identified by a driver-specific, 3-character tag.

In the HARDWARE System tab, under **Synchronize Computer Clock**, select the GPS_Sync_Only driver.

DRIVER SETUP

FIGURE 1. GPS_Sync_Only Driver Setup

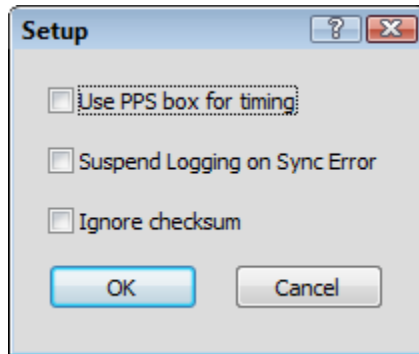

Use PPS Box for Timing indicates whether you are using a HYPACK PPS box.

Suspend Logging on Sync Error: SURVEY only logs data when the system time-tags are synchronized.

Ignore Checksum

DEVICE OUTPUT STRINGS

ZDA NMEA message at 1Hz.

DRIVER OUTPUT

Scrolling display of the Sync Error and the Time Source: ZDA or PPS.

FIGURE 2. GPS_Sync_Only Device Window

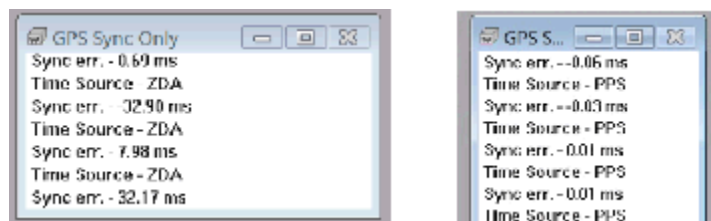

SPECIAL NOTES

It usually takes HYPACK® SURVEY about 30-45 seconds to fully synchronize. During this time you will notice a NO SYNC alarm the

device window and in SURVEY. Once the alarm goes away, your computer should be fully synchronized to ZDA or PPS and you will be all set to survey.

F180.DLL

Version Number: 13.0.1.8

Device Name: Coda Octopus F180

DEVICE SETUP

Position: Logs position data from this device.

Heading: Logs heading data from this device.

Speed: Displays speed data from this device.

Tide: Logs tide data from this device.

Heave: Logs heave, pitch and roll data from this device.

NOTE: For Multibeam surveys, you can leave Heading and Heave unchecked as these will be received by HYSWEEP® SURVEY. If you leave them checked, they are recorded to the RAW files.

DRIVER SETUP

Synchronization

In any survey, accurate time-tagging is of paramount importance. There are two typical cases:

- **Multibeam survey without any additional equipment.** Many multibeam systems can receive a PPS pulse and time information from the F180 system directly. Because all equipment (F180 and multibeam) is already synchronized to the UTC time, HYPACK® does not need to take care of synchronization. In this case:
 - Select **'Use F180 time-tags even when not synchronizing'** in the device setup.
 - Do *not* select the F180 device under **'Synchronize the Computer Clock'** on the System tab of HYPACK® HARDWARE.
- **Other equipment is connected to HYPACK® system.** In this case, you need to synchronize computer clock with UTC time because time tags for the other devices need to be consistent

with F180 and multibeam time-tags. You must do exactly the opposite of the previous case:

- Select '**Use PPS signal for synchronization**' and enter the COM port to which the PPS box is connected.
- Select the F180 driver under '**Synchronize the Computer Clock**' on the System tab in HYPACK® HARDWARE.

Heave

Use online heave (recommended): Real-time heave correction from the MCOM message. This option is recommended because processing is better done in post-processing.

Use long period heave: Processed heave values.

Downsample:

The default value is 100Hz. Choose one of the other options to reduce the amount of data recorded without affecting the rate the data is read by the driver.

Solution status for RTK Tides:

The default setting is both options unchecked which results in logging only when the device is in RTK Fixed mode.

The solution status options are 'exceptions to the default':

- **Always calculate tide** records tide values regardless of the RTK status. In this case, you will filter out tides where the RTK status was not acceptable during post-processing.
- **Calculate tide in RTK float mode** records tide values only when you have RTK Fixed or RTK Float status.

DEVICE OUTPUT STRINGS

MCOM data

IMPORTANT: Start logging this data at least 5 minutes before HYPACK®/HYSWEEP® data collection and continue logging at least 5 minutes after HYPACK®/HYSWEEP® data collection.

DRIVER OUTPUT STRINGS

DEVICE WINDOW

FIGURE 1. Testing F180 Communications

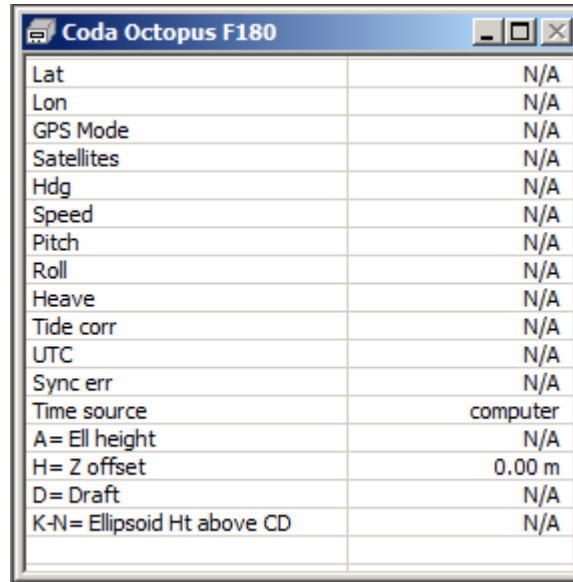

Coda Octopus F180	
Lat	N/A
Lon	N/A
GPS Mode	N/A
Satellites	N/A
Hdg	N/A
Speed	N/A
Pitch	N/A
Roll	N/A
Heave	N/A
Tide corr	N/A
UTC	N/A
Sync err	N/A
Time source	computer
A = Ell height	N/A
H = Z offset	0.00 m
D = Draft	N/A
K-N = Ellipsoid Ht above CD	N/A

Note the “Time Source” shown.

- “**MCOM**” will be displayed with clock sync and “Use F180 time tags” checked in the driver setup.
- “**PPS**” will be displayed with clock sync and “Use PPS signal for synchronization” checked.
- “**Equipment**” will be displayed with no clock sync and “Use F180 time tags” checked in the driver setup.
- “**Computer**” will be displayed with no clock sync and no sync options chosen.

SPECIAL NOTES

CONFIGURING YOUR DATA COLLECTION PC

Set up the F180 control software and verify that it’s communicating with the F180 system.

Be sure to set your network card to the proper configuration for communication with the F180. This is important for both communication with the F180, and for logging their MCOM data real-time. The MCOM data is necessary to generate their “i-heave”

file, a post-process heave component which can be imported into the HYPACK® editing programs.

FIGURE 2. F180 IP Settings

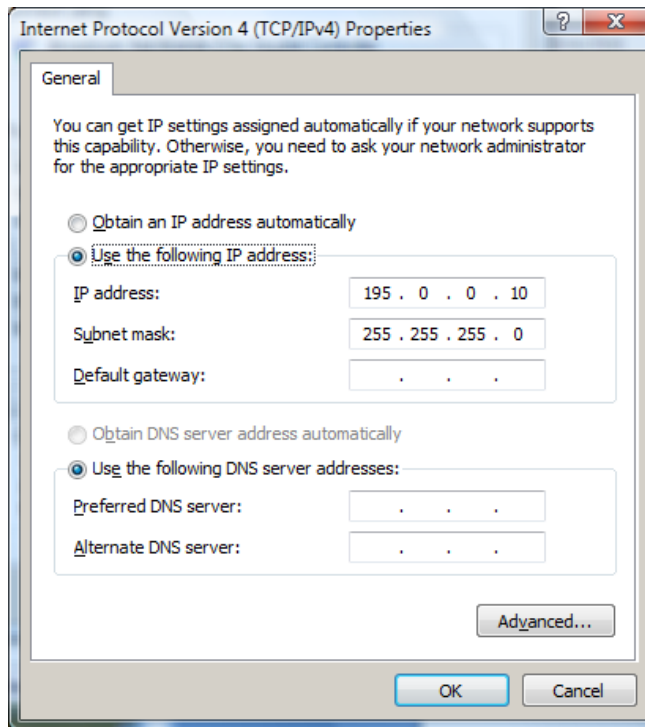

The F180's IP address is 195.0.0.180, so you can use any 4th value other than 180. Set the Subnet Mask to 255.255.255.0.

CONNECTION SETTINGS

The F180.dll defaults to the default connection settings.

- CONNECT: Network Port,
- PROTOCOL: UDP
- ROLE: Server
- PORT: 3000.

OFFSETS

Enter your offsets relative to the vessel's reference point as entered in the F180 software configuration. If you are using RTK for water levels, make sure you measure the F180 reference point relative to the water level in order to calculate the proper levels in real-time in HYPACK® SURVEY.

GENOFFSET.DLL

This driver used to calculate the position of a reference point on your vessel that has no data coming from it. It can be used in Survey by assigning it to an "other mobile". By doing this you can see the point on your Survey screen and display data about it (position and heading) in the data display window. You can also use it to align that point with your survey line by selecting that mobile as your primary vessel and positioning yourself according to the left/right indicator.

This can be very helpful to locate your spud on a dredge or a side scan sonar on the side of your vessel.

Version Number: 15.5.0.3

Device Name: HYPACK® Generic Offsets driver

DEVICE SETUP

Position: Logs position data from this device.

This driver calculates the position of your reference point which has been calculated using the boat position and the offsets entered in the Driver Setup.

Heading: Logs heading data from this device.

This driver uses the boat heading as heading for this reference point.

DRIVER SETUP

FIGURE 1. Driver Setup

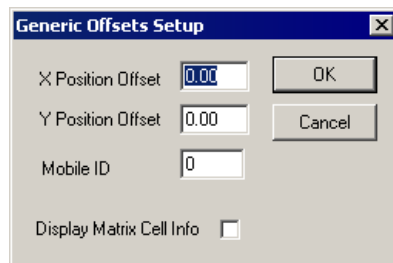

X Position and **Y Position** are the offsets of your reference location from your boat origin.

Mobile ID: This option is obsolete. It has been replaced by the "Position Relative to" option in the Advanced tab of HYPACK

HARDWARE where you set the mobile from which you want to offset with this driver.

Display Matrix Cell Info: Shows the matrix cell information at the current position in the Data Display. Without this option, you can configure the Data Display but not show the values.

DEVICE OUTPUT STRINGS

None

DRIVER OUTPUT STRINGS

DEVICE WINDOW

The device window enables you to change the offsets while you're in SURVEY or DREDGEPACK®

FIGURE 2. Sample Device Window

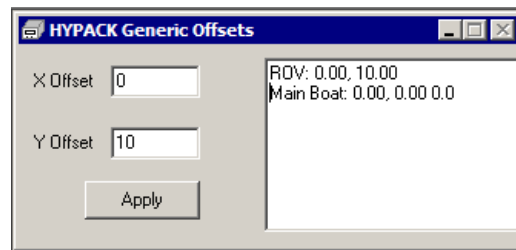

SPECIAL NOTES

This can only work if HYPACK® is getting the heading of your boat. This means that either of the following:

- HYPACK® has to receive a string that contains heading
- Your boat has to be moving so that HYPACK® can calculate the heading using the change of position over time.

USING THE GENOFFSET DRIVER TO DISPLAY THE PROGRESS OF A BAR DRAG IN HYPACK® SURVEY

FIGURE 3. Diagram of Sample Vessel Configuration

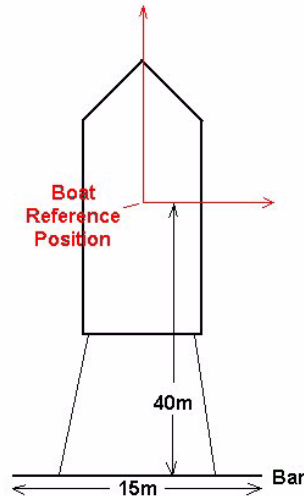

In order to do this, you will need a matrix file that contains the depth information. If you don't have any depth information, you can always use a blank matrix and use the bar depth to fill the matrix to show your progress.

In the HARDWARE program, configure it as you normally would for your main vessel (GPS, Gyro, etc.). Set up the barge as another mobile, even though its position will be fixed relative to the main ship.

This example fixes the bar 40m behind the vessel origin of the main ship. The Bar will be positioned using the GenOffset device driver. The Bar depth is created using the Sim32 device driver as a multiple transducer system. This example uses 5 transducers with a spacing of 3m to result in a coverage length of 15m. (The matrix cells are 3m x 3m and the spacing of the transducers is equal to or less than the size of my matrix cells.)

BAR POSITION

In the HARDWARE program, once you have configured your main ship, add the **GenOffset.DLL** (HYPACK® Generic Offsets).

Under **Function**, tell the device that it is a position device.

Set the **Update Frequency** for 500 ms. This means that SURVEY will update the position of the bar two times per second. There is no need to update any faster, unless you notice the bar is 'skipping' matrix cells when painting them because the bar position is not updating fast enough.

Under **Offsets**, leave all of the offsets set for 0.0.

Under the **Setup** window, specify the distance the bar is to be located relative to the boat origin of the main vessel. In this example, it is 40m behind the origin.

FIGURE 4. *Generic Offsets Dialog*

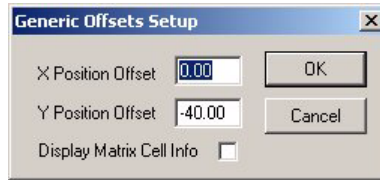

BAR DEPTH

Click [Add Device] and select the Sim32.dll (HYPACK® Generic Simulator) driver.

Under the device **Type**, select 'Depth' and nothing else.

Also, make sure you check the '**Use for matrix update**' and that no other device from your main vessel setup has this checked. This instructs SURVEY to use the depth of the bar to paint the matrix.

Set the **Update Frequency** to 500 ms, which should be OK for this operation.

All of the **Offsets** for the Bar Depth driver should be set to 0.0.

Click **Setup**. Leave it set to '**Random**' (although there is nothing random about this).

FIGURE 5. *Simulator Driver Setup*

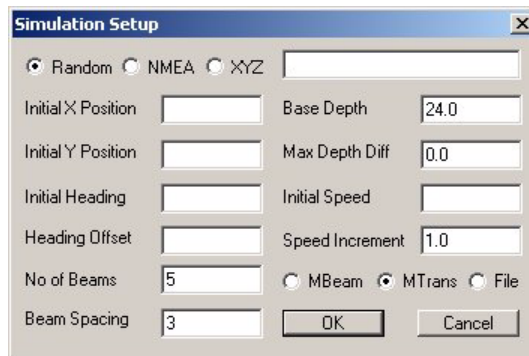

Set the '**Number of Beams**' to 5 and the '**Beam Spacing**' to 3. This results in a bar that is 15m in length ($3 \times 5 = 15$). If you have a different length bar, you can vary these two settings so that their product equals the length of the bar. Just keep the Beam Spacing equal to or less than the size of your matrix cells.

Set the '**Base Depth**' to 24.0m. You should set this to the initial depth you intend to place the bar. You will be able to change this on-the-fly in SURVEY, which is the usual process. The important thing is to set the **Maximum Depth Difference** = 0.0. This means that the depth will be fixed to the Base Depth value and will not vary from it.

BAR MOBILE

Create the 'Bar' Vessel and Assign the Devices to it.

1. In HARDWARE, click [Add Mobile] and name it. (This example uses 'Bar'.)
2. Select the Bar Position device and set the Mobile Assignment to Bar.
3. Repeat Step 2 for the Bar Depth device.
4. Exit HARDWARE and you are ready to begin SURVEY.

BOAT AND BAR SHAPES (OPTIONAL)

Create HYPACK® Boat Shape files for the main vessel and for the bar as shown below.

FIGURE 6. Sample Boat Shape File in the Boat Shape Editor

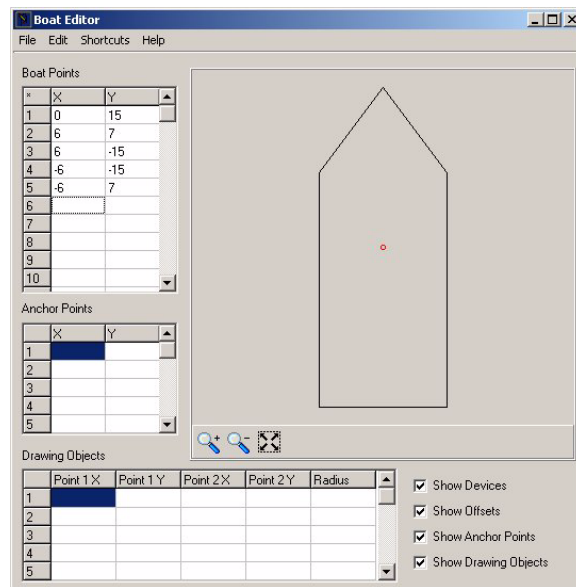

SURVEY MATRIX OPTIONS

In SURVEY, set the Matrix options to update using the **Maximum Depth** value, so that if the bar is above the bottom, the bottom will not update.

FIGURE 7. Matrix Options in SURVEY

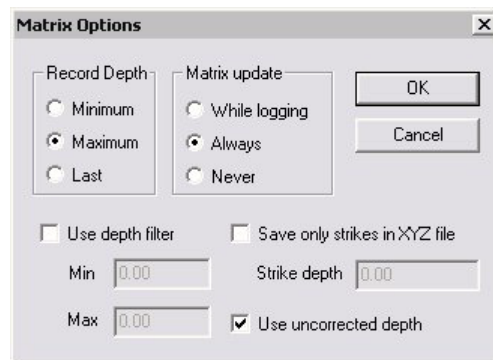

This example is set up so that the Bar Depth will 'Always' update the matrix. You might want to set yours to 'While Logging', if you only want it to update the matrix while you are actually 'On Line'.

The last setting to be concerned about is the '**Use Uncorrected Depth**' check box. If this is checked, it will use the depth as specified in the Bar Depth driver (=24.0m) without adding any tide or draft correction to it. If you have this box un-checked, it will add the tide and draft to the depth from the Bar Depth driver to obtain a corrected depth that is then used for updating the Matrix.

CHANGING THE BAR DEPTH IN SURVEY

You should be able to find a window with the title 'Bar Depth' (if that is what you named the device during the configuration in HARDWARE.) Click on the Setup button in this box to change the depth of the bar at any time.

FIGURE 8. Boat and Bar in SURVEY

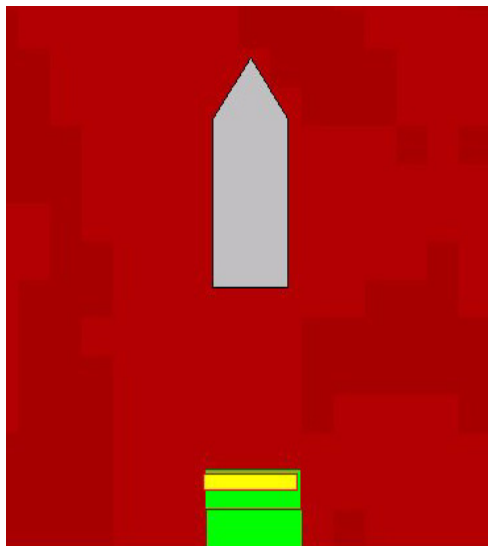

HYDROID.DLL

Version Number: 15.0.0.0

Device Name: Hydroid

DEVICE SETUP

Position: Logs position data from this device.

Heading: Logs heading data from this device.

SURVEY uses the Course Made Good from the VTG, RMC or HDT message, or calculates the vessel orientation based on the change in position over time.

Draft: Logs draft data from this device.

DRIVER SETUP

FIGURE 1. Driver Setup

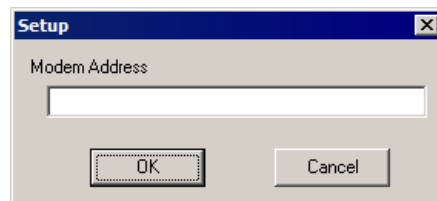

Set the Modem Address to select which AUV you want to follow.

DEVICE OUTPUT STRINGS

#ID DeviceID POSITION lat lon, depth(m), heading, speed(m/sec), mission leg

Data Sample:

```
#CONNECT
#STATUS DR1_100 (8) DR1 Mission
#ID 8 POSITION 59N30.1414 10E25.9202, DEPTH 0.1 M, HEADING
124.0 DEG, SPEED 0.00 M/SEC
#STATUS DR1_100 (8) DR1 Mission
#ID 8 POSITION 59N30.1514 10E25.9202, DEPTH 0.1 M, HEADING
124.0 DEG, SPEED 0.00 M/SEC
```

```
#ID 8 POSITION 59N30.1614 10E25.9202, DEPTH 0.1 M, HEADING  
124.0 DEG, SPEED 0.00 M/SEC  
#STATUS DR1_100 (8) DR1 Mission
```

DRIVER OUTPUT

DEVICE WINDOW:

Displays X, Y, Depth, Hdg, Speed, Leg

The status bar displays the current data string from which the data is derived.

SPECIAL NOTES

CONNECTION

TCP, Port = 12100 and IP of the computer running the VIPRE server.

The driver listens to the configured port for the #ID messages from the server. The #ID message contains the lat./long., heading and depth of the AUV.

IXSEA_USBL.DLL

Version Number: 14.1.13.2
Device Name: IXSEA USBL

DEVICE SETUP

Position: Logs position data from this device.
Heading: Logs heading data from this device.
Heave: Logs pitch and roll data from this device.

DRIVER SETUP

FIGURE 1. Driver Setup Dialog

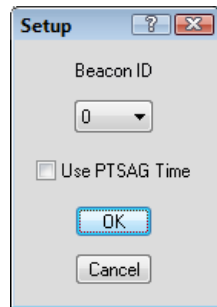

Beacon ID: Beacon Number you will track.
Use PTSAG Time:

DEVICE OUTPUT STRINGS

\$PTSAG message

Format	\$PTSAG,#seq,t,d,m,y,ID,Lat,N/S,Lon,E/W,Valid,0000,0000*ck	
Where	#seq	Sequence
	t	Time (hhmmss.sss)
	d	Day
	m	Month

Format	\$PTSAG,#seq,t,d,m,y,ID,Lat,N/S,Lon,E/W,Valid,0000,0000*ck	
	y	Year
	ID	Beacon ID: 0=ship, 1 to 128: beacon
7	Lat	Latitude
	N/S	Hemisphere
	Lon	Longitude
	E/W	Direction
11	PosV	Horizontal Position Validity: F is valid, 0 is invalid
12	BDep	Beacon Depth
13	DepV	Beacon Depth Validity: 0=no depth, 1=Calculated, 2=Sensor
14	SDep	Sensor Depth (meters). "9999" = no depth sensor
15	*ck	Checksum
Sample Line	\$PTSAG,#00035,100750.472,12,09,2007,00,4214.434,n,00843.85 1,W,F,0000,0000*08	

Beacon can be equipped with a depth sensor. Calculated beacon depth is the fusion between sensor depth and calculated USBL depth. If Ship position is sent, the last 3 fields are set to 0.

The IXSEA GAPS system outputs absolute position in lat/lon.

DRIVER OUTPUT STRINGS

DEVICE WINDOW:

Real-time listings of the following data:

- Transponder
- X
- Y
- Lat
- Lon
- Position Flag
- Calculated Depth
- Depth Flag
- Sensor Depth
- Message
- Current Message

FIGURE 2. Sample Device Window

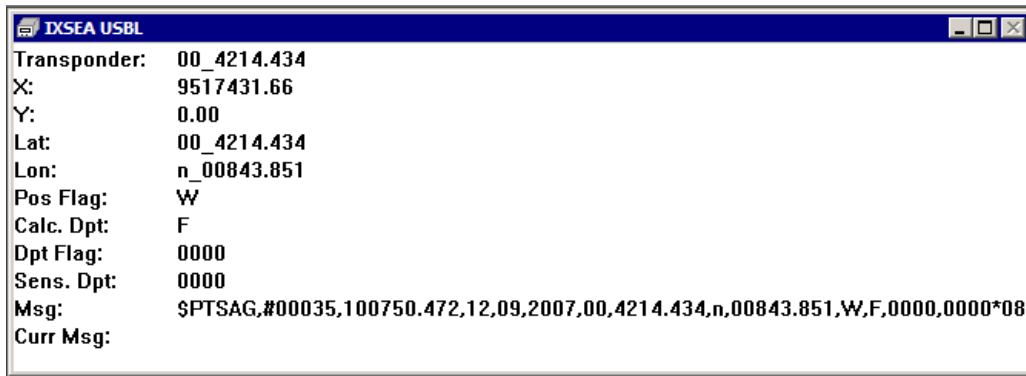

SPECIAL NOTES

MAVLINK.DLL

Version Number: 17.1.0

Device Name: MAVLink

DEVICE SETUP

Position: Logs position data from this device.

Heading: Logs heading data from this device.

DRIVER SETUP

None.

CONNECTION SETTINGS

The Seafloor Systems AutoNav was connected through serial to radio.

DEVICE OUTPUT STRINGS

<http://mavlink.org/messages/common>

https://github.com/mavlink/c_library_v1

https://github.com/mavlink/c_library_v2

DRIVER OUTPUT

DEVICE WINDOW:

When the driver recognizes the device, the following occurs:

- “Not Connected” changes to “Unarmed”
- “No position information” changes to “3D position”.
- GPS status
- Arm status (To arm the device, push the button on the device which engages the motors.)

[Send Waypoints] sends the waypoints from the line file to the MAVLink device and enables **[Start Mission]**.

[Start Mission] starts the mobile along its path. When the mission begins, the text changes to **[Stop Mission]** that, when clicked, will terminate the mission.

[Pause] pauses the mission. When the mission is paused, the text changes to **[Resume]** that, when clicked, will continue the current mission.

[Return to Launch] brings the mobile back to the launch location.

SPECIAL NOTES

Interfaces with line files that follow MavLink protocol (containing MavLink waypoints). The HYPACK® LINE EDITOR can export to *.waypoints for this purpose.

NOVATEL.DLL

Version Number: 16.0.1.15

Device Name: Novatel SPAN-SE

DEVICE SETUP

Position: Logs position data from this device.

Heading: Logs heading data from this device.

Speed: Displays speed data from this device.

Heave: Logs heave, pitch and roll data from this device.

Tide: Logs tide data from this device.

Record Raw Data: Records Lat./Lon. (in dec. degrees), antenna height above ellipsoid, UTC time to RAW records.

Record Quality Data:

TABLE 1. Position Quality Information

Format	QUA dn t n m h sat mode	
Where	dn	device number
	t	time tag (seconds past midnight)
	n	number of values to follow
	m	10 minus HDOP
	h	HDOP
	sat	number of satellites
	mode	GPS mode (NMEA 0183 standard values) 0 = fix not available or invalid 1 = Stand-alone 2 = Differential 3 = RTK Float 4 = Wide lane fixed RTK 5 = Narrow lane fixed RTK

Format	QUA dn t n m h sat mode	
	The following 3 values are decoded from GST message:	
	sigman	standard deviation of latitude error (meters)
	sigmae	standard deviation of longitude error (meters)
	semimaj	Standard deviation of semi-major axis of error ellipsis (meters)
	Remaining values are present only if synchronizing computer clock with GPS clock:	
	ref	reference time at last sync (milliseconds since midnight)
	var	computer clock at last sync (milliseconds since midnight)
	syna	computer clock frequency adjustment factor (microseconds per sec)
	syne	filtered synchronization error (milliseconds)
	syms	synchronization status. Binary code with the following bits (other bits are not meaningful) 1 = not in sync 2 = low accuracy synchronization 4 = high accuracy synchronization 8 = synchronization failure
	synb	computer clock phase adjustment status
Sample Line	QUA 0 33643.186 4 8.000 2.000 7.000 2.000 QUA 0 50040.509 7 9.083 0.917 9.000 2.000 0.000 0.000 0.000 QUA 0 30285.600 13 8.700 1.300 7.000 4.000 0.059 0.033 0.059 30284964.000 30284964.000 2.584 0.028 34.000 26131962158.485	

Record Raw Messages: Logs the data string to the raw file as it is originally received from the device.

Record device specific messages: Logs additional data related to the device to the Raw file. Each record will be identified by a driver-specific, 3-character tag.

DRIVER SETUP

FIGURE 1. Driver Setup

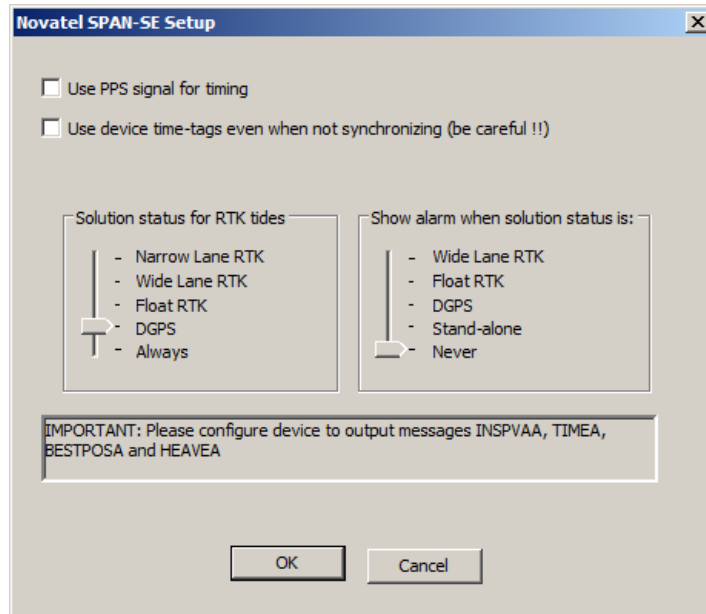

Use PPS Signal for Timing improves the time-tagging to within 100 microseconds. This requires a special interface device available through HYPACK, and ZDA output from your GPS. You must also check the 'Sync Clock' option in the vessel's System dialog. If you are not using a PPS box, the computer time will be used.

Use Device Time Tags even when not synchronizing: If you use two GPS receivers and you are synchronizing your computer clock with UTC time, only the first GPS is synchronizing the computer clock with the GPS clock. However, the driver for the second GPS can safely use the UTC time tag included in the GPS message because any two GPS receivers are synchronized to UTC time. When the checkbox is checked the driver assumes that the computer clock is synchronized with the GPS clock and records position messages using the UTC time provided by the GPS receiver.

Alternatively, you can also choose to synchronize the computer clock to the SPAN under HYPACK CONFIGURATION.

Solution status for RTK Tides: Uses information in the GGA or GGK strings to measure the tide. Set the slider for the minimum GPS status at which your RTK GPS will calculate tide corrections.

Show alarm when solution status is: Set the maximum status at which an alarm should be displayed in SURVEY.

DEVICE OUTPUT STRINGS

The device can be configured in many different ways. HYSWEEP® expects a TCP network connection. The device's default IP address and port are 192.168.0.10, port 3000. To configure the device, a series of commands need to be sent to it using the Novatel CDU software:

- HYPACK® requires INSPVAA, TIMEA, BESTPOSA and HEAVEA datagrams.
- HYSWEEP® requires INSPVAA, TIMEA and HEAVEA datagrams.

The easiest way to configure the system is to create a text file with the following information:

```
LOG ICOM2 BESTPOSA ONTIME 0.2
LOG ICOM2 HEAVEA ONNEW
LOG ICOM2 INSPVAA ONTIME 0.05
LOG ICOM2 TIMEA ONTIME 1
LOG ICOM3 INSPVAA ONTIME 0.05
LOG ICOM3 HEAVEA ONNEW
LOG ICOM3 TIMEA ONTIME 1
SAVECONFIG
```

In the CDU software, select TOOLS – RUN BATCH and browse for the text file you just made and click [RUN]. Your SPAN should now be configured to work with HYPACK® and HYSWEEP®.

In addition to the specific datagrams, the batch file is also configuring the SPAN to send these datagrams out specific ports.

- The “ICOM2” command is sending the 4 datagrams to Port 3001 required in HYPACK®.
- The “ICOM3” command is sending the 3 datagrams to Port 3002 required in HYSWEEP®.

With the CDU software connected to Port 3000, you can run HYPACK®, HYSWEEP® and CDU simultaneously over separate ports, all sharing one Ethernet cable.

DRIVER OUTPUT STRINGS

Network packet

DEVICE WINDOW:

A static table with updating values.

FIGURE 2. Sample Device Window

Novatel SPAN-SE	
Lat	41°35.6177 N
Lon	072°43.4214 W
Pos. type	INS_PSRSP
Sol. status	SOL_COMPUTED
Satellites	9
Hdg	162.86
Speed	0.02
Pitch	0.42
Roll	0.01
Heave	-0.01
Sync err	N/A
Time source	SPAN
A= Ell height	8.94 ftUS
H= Z offset	0.00 ftUS
D= Draft	0.00 ftUS
K-N= Ellipsoid Ht above CD	0.00 ftUS
Tide corr	-8.96 ftUS

OUTPUT PORT:

None

SPECIAL NOTES

- Code for message logging same as GPS.dll.13.0.11.12.
- You can also choose to synchronize the computer clock to the SPAN under HYPACK CONFIGURATION.
- Standardized status code:
 - 0: Invalid
 - 1:C/A
 - 2:DGPS
 - 3:Float
 - 4:Wide lane
 - 5:Narrow lane

SPAN-SE Ethernet Connection

The SPAN-SE receiver has a unique Media Access Control (MAC) address, hard coded into flash, and user-configurable IP information. There are four ports available for Ethernet: Ports 3000, 3001, 3002 and 3003. These ports are used to access ICOM1, ICOM2, ICOM3 and ICOM4 respectively. Each port can be used for either Transmission Control Protocol (TCP) or User Datagram Protocol (UDP) traffic, but not simultaneously.

The SPAN-SE uses a static IP address. There is no Dynamic Host Configuration Protocol (DHCP) support on the SPAN-SE.

An FTP port is available for transfer of data files from the data logging SD Card. The receiver is shipped with the following default configuration:

- Default IP: 192.168.0.10
- Default mask: 255.255.255.0
- Default Gateway: 192.168.0.1

The MAC address is available to through the MAC log

NTRIP.DLL

Dedicated to receiving NTRIP corrections and sending them to a GPS.

Version Number: 17.1.1

Device Name: NTRIP Out

DEVICE SETUP

Generate Output Messages: Generates messages or data outside of the Raw file.

DRIVER SETUP

NTRIP (Network Transport of RTCM via Internet Protocol) enables you to receive your differential or RTK corrections on your survey computer over an Internet connection. The stream server (or caster) receives the corrections from GPS stations and sends them to their clients (in this case HYPACK® users).

Do an Internet search to locate an NTRIP caster service. They can provide information about RTCM output format versions and output strings, as well as supported GPS models.

IMPORTANT: You must configure your GPS receiver to accept the corrections through the port defined under 'Connections' for the NTRIP.dll. To assure proper communication, be sure the baud rate of the NTRIP driver matches with the baud rate set in the GPS.dll.

FIGURE 1. NTRIP Driver Setup

The screenshot shows the NTRIP Driver Setup dialog box. It features a title bar with the text "NTRIP" and a close button. The main area contains several fields and buttons: "Streams server" is a dropdown menu showing "www.igs-ip.net" with a "Set Default" button to its right; "Port" is a text box containing "2101"; "Load Streams List" is a button below the port field; "Corrections stream" is a dropdown menu with a "Details" button to its right; "User name" is a text box containing "user"; "Password" is a text box containing "password"; "Simulated coordinates" and "Init coordinates" are checkboxes; "Latitude" is a text box containing "00°00.0000'N"; "Longitude" is a text box containing "000°00.0000'E"; "Advertise as NTRIP Ver. 2 Client" is a checked checkbox; and "OK" and "Cancel" buttons are at the bottom.

Streams Server: Address of the stream server.

Port: Most stream servers use port 2101.

[Load streams list]: After you have entered the stream server address and port, click this button to populate the list of corrections streams.

[Details] displays information about the station from which you are reading data.

Correction Stream: Select the corrections stream closest to your project area.

User name and **Password:** Required only if you must pay to subscribe to the stream. (Some casters are free!)

Simulated Coordinates: Position coordinates for office testing only.

Initial Coordinates: User-defined Lat/Lon coordinates at your project location. NTRIP corrections are based on this location.

Advertise as NTRIP Ver. 2Client: If checked the driver will inform the server that it is a version 2 compatible client and will accept replies according to this newer version of the NTRIP standard.

DEVICE OUTPUT STRINGS

None.

DRIVER OUTPUT STRINGS

DEVICE WINDOW:

A table showing the following values:

- Bytes Received
- Data Rate
- Server Reply
- Status

SERIAL PORT:

Binary data received from the NTRIP caster.

SPECIAL NOTES

Because in HYPACK® you can share your serial ports between different device drivers, you can (and usually do) just add this driver to send differential corrections to the GPS on the same port on which you are receiving GPS positions.

IMPORTANT: To assure proper communication, be sure the baud rate of the NTRIP driver matches with the baud rate set in the GPS.dll.

PHINS.DLL

Photonic Inertial Navigation System outputs position, heading, roll, pitch, depth, velocity, and heave.

Version Number: 17.2.4

Device Name: IXSEA Phins

DEVICE SETUP

Position: Logs position data from this device.

Heading: Logs heading data from this device.

Speed: Displays speed data from this device.

Heave: Logs heave, pitch and roll data from this device.

Tide: Logs tide data from this device.

Record Raw Messages: Logs the data string to the raw file as it is originally received from the device.

NOTE: Raw messages can only be recorded if you have selected the ASCII Input Data Format in the Driver Setup.

Record Raw Data: Records Lat./Lon. (in dec. degrees), antenna height above ellipsoid, UTC time to RAW records.

Record Quality Data: Logs data indicative of the positioning accuracy. QUA records include HDOP, Number of Satellites and GPS Mode, which can be used in post-processing to filter data with sub-standard positioning.

DRIVER SETUP

FIGURE 1. Device Setup

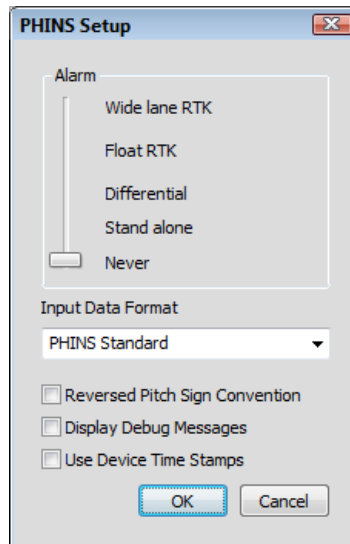

Alarm: HYPACK® SURVEY shows an alarm at the defined GPS Mode or less.

Input Data Format: Binary or ASCII

Reversed Pitch Sign Convention:

Display Debug Messages: Displays data in a scrolling window vs. in a table format. (Allows HYPACK programmers to troubleshoot problems with the driver.)

DEVICE OUTPUT STRINGS

- "LONG BINARY NAV" message
- Phins Standard (ASCII):

```
$HEHDT,320.195,T*23
$PIXSE,ATITUD,0.180,-0.197*49
$PIXSE,POSITI,37.38358756,127.12431135,66.568*69
$PIXSE,SPEED_,-0.099,0.026,-0.001*64
$PIXSE,UTMWGS,S,52,333942.828,4139076.994,66.568*2D
$PIXSE,HEAVE_,-0.001,-0.000,0.031*7A
$PIXSE,STDHRP,2.000,0.096,0.103*7F
$PIXSE,STDPOS,3437.65,3421.02,896.05*42
$PIXSE,STDSPD,10.777,10.838,10.001*49
$PIXSE,TIME__,001056.000*5E
$PIXSE,ALGSTS,00000015,00004000*65
$PIXSE,STATUS,00000000,00000000*6F
$PIXSE,HT_STS,07FF5551*43
```

DRIVER OUTPUT STRINGS

DEVICE WINDOW:

Displays data read in a fixed grid display.

SPECIAL NOTES

The device delivers heave in a separate message from pitch and roll. If only one of the two required sentences is present, no motion data is reported at all. Data is also throttled to whatever rate is the slower of the two, so it is recommended to output both at the same rate.

-

POS MV.DLL

The POS MV is a Position and Orientation System that outputs position, heave, pitch, roll and heading data. Data output may be through network (ethernet) or serial connection to the survey computer.

There are drivers for the POS MV in both HYPACK® HARDWARE and HYSWEEP® HARDWARE. The following describes HYPACK® HARDWARE configuration. Refer to the *HYSWEEP® Interfacing Notes* for details on the HYSWEEP® HARDWARE configuration.

Version Number: 15.0.7.6

Device Name: TSS POS MV

DEVICE SETUP

Position: Logs position data from this device.

Heading: Logs heading data from this device.

Tide: Logs tide data from this device.

Speed: Displays speed data from this device.

Heave: Logs heave, pitch and roll data from this device.

Record Raw Messages: Logs the data string to the raw file as it is originally received from the device.

POS MV messages are binary but the driver converts them to an ASCII format similar to the output of the POSCONV utility from Applanix.

Record device specific messages: Logs additional data related to the device to the Raw file. Each record will be identified by a driver-specific, 3-character tag.

DRIVER SETUP

FIGURE 1. PosMV Driver Setup Dialog

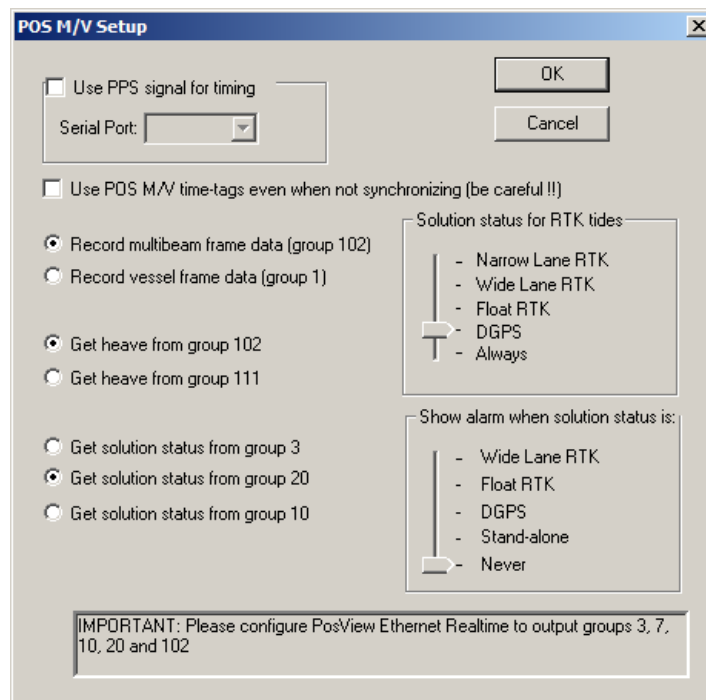

Use PPS signal for timing: Select this option if you have a PPS box connected to the POS MV. Select the serial port where the PPS box is connected.

NOTE: *Only the PPS cable should be connected between the PPS box and the POS MV unit.*

Use POS MV time-tags even when not synchronizing: Check this option if you are using the POS MV with a multibeam system that is synchronized outside of HYPACK system. *Normally you should not have any other device in your configuration as their time tags are not going to be consistent with the POS MV time-tags.*

Record multibeam frame data. (Group 102). This returns position data at a location called “sensor 1” in Applanix documentation. This is normally the multibeam sensor head, but it can be any user-specified point. (It does the same thing as group 1 with all ‘0’ offsets.)

Record vessel frame data Group 1). Records the data at the POS MV reference point.

NOTE: We have not yet seen a successful configuration using Group 1. If you have and are willing to share your project, we would love to see it!

Get heave from group 102 Recorded real-time heave value comes from group 102 (heave at location of multibeam head)

Get heave from group 111 Recorded real-time heave value comes from group 111. (heave at location of multibeam head)

Get solution status from group xx. Set this option according to the version of the POS MV you are using. POS MV Version 3 does not have message 20. Selecting different messages for solution status gives contradictory results. (See “Status”.)

Solution status for RTK tides: The slider only controls the calculation of the tide value. If solution status equals or is worse than the selected one, the driver does not calculate tide in real-time. Enter Float RTK to record the most data. You can filter the lower settings in post-processing if you want to.

Show alarm The driver will generate an alarm when solution status equals or is worse than the selected one.

DEVICE OUTPUT STRINGS

Binary output strings. The driver decodes the following messages:

- Group 1 - Vessel Position Attitude and Dynamics
- Group 2 - Vessel Navigation Performance Metrics (error ellipsis)
- Group 3 - Primary GNSS status (Driver reads code 13 as equivalent to differential GPS.)
- Group 7 - PPS Time Recovery and Status
- Group 10 - General Status and FDIR
- Group 20 - IIN Solution Status
- Group 102 - Sensor 1 Position, Velocity, Attitude, Heave & Dynamics
- Group 111 - Heave & True Heave Data

DRIVER OUTPUT STRINGS

DEVICE WINDOW

Writes data to a table.

FIGURE 2. Sample POS MV Display.

Applanix POS M V Network		
Lat		N/A
Lon		N/A
Height		N/A
IIN Mode		N/A
Satellites		N/A
Hdg		N/A
Speed		N/A
Pitch		N/A
Roll		N/A
Heave		N/A
Sync err		N/A
Time source	computer	
Nav Mode		N/A
A = Ell height		N/A
H = Z offset	0.00 ft	
D = Draft		N/A
K-N = Ellipsoid Ht above CD		N/A
Tide corr		N/A

SPECIAL NOTES

CONNECT OPTIONS

The driver initially sets the connect settings to the defaults from the manufacturer:

- **Connect:** Network
- **Protocol:** UDP
- **Role:** Server
- **Host:** N/A
- **Port:** 5602

SYNCHRONIZING TO THE POS MV TIME

In any survey, accurate time-tagging is of paramount importance. There are two typical cases:

- **Multibeam survey without any additional equipment.** Many multibeam systems can receive a PPS pulse and time information from the POS MV system directly. Because all equipment (POS MV and multibeam) is already synchronized to the UTC time, HYPACK® does not need to take care of synchronization. In this case:
 - Select *Use POS MV time-tags even when not synchronizing* in the device setup.
 - Select POS MV device under *Synchronize the Computer Clock* on the System tab of HARDWARE.
- **Other equipment is connected to HYPACK® system.** In this case, you need to synchronize the computer clock with UTC

time because time tags for the other devices need to be consistent with the POS MV and multibeam time-tags.

- Clear the *Use POS MV time-tags even when not synchronizing* option in the device setup.
- Select POS MV device under *Synchronize the Computer Clock* on the System tab of HARDWARE.

STATUS

Solution status is described in different output groups. Refer to the POS MV manual for group descriptions.

The HYPACK® standardized code is stored to the first field in the HYPACK® QUA string as follows:

- Invalid = 0
- Stand-alone = 1
- DGPS = 2
- Float RTK = 3
- Wide Lane RTK = 4
- Narrow Lane RTK = 5

POS MV provide various "solution status" information in different messages and with different directions for what a better status means. Also sometimes the solution status is encoded as a number and sometimes as a bit code. To try to standardize the different codes we have defined a "standardized status code" and we map the different POS MV values to this standardized status code.

The code is dependent on the POS group selected, and also the position system used (internal gps/external receiver).

The original POS/MV code (which can vary between POS/MV messages) is stored as the 4th field in the QUA string.

The following tables try to explain the process of mapping POS MV codes to standardized status codes.

Version 3

For version 3 POS MV, the status information comes from group 3 and has the following values:

Condition	POS MV code	Standardized code
No Solution	0	0
2D C/A	1	1
3D C/A	2	1
2D DGPS	3	2
3D DGPS	4	2
Float	5	3

Condition	POS MV code	Standardized code
Wide Lane	6	4
Narrow Lane	7	5
P-Code	8	1
HP Omnistar	9	2
XP Omnistar	10	2
VBS	11	2

Note that up to a point (narrow lane RTK) higher numbers mean better solution but then the direction changes.

Version 4 and 5

For **version 4 and version 5** the status codes can be taken from group 10 or group 20.

Group 20 defines the following status codes:

Condition	POS MV code	Standardized code
No Solution	7	0
GPS Nav	6	1
Autonomous	5	1
RTCM DGPS	4	2
Code DGPS	3	2
Float RTK	2	3
Wide Lane RTK	1	4
Narrow Lane RTK	0	5

If it is taken from **group 10**, certain bits in the status word B of the message 10 define the solution mode:

- bit 13 is set - primary GPS solution in use
- bit 25 is set - auxiliary GPS solution in use
- otherwise it is a tightly coupled solution.

In the case of **primary GPS solution**, bits 18 to 22 of status word B define the solution status:

Condition	POS MV flag	POS MV code	Std. code
No Solution	no bit set	7	0
stand-alone	bit 18 set	5	1
DGPS	bit 19 set	3	2
Float RTK	bit 20 set	2	3

Condition	POS MV flag	POS MV code	Std. code
Wide Lane RTK	bit 21 set	1	4
Narrow Lane RTK	bit 22 set	0	5

In the case of **auxiliary GPS solution**, bits 27 to 30 of status word B define the solution status:

Condition	POS MV flag	POS MV code	Std. code
No Solution	no bit set	7	0
DGPS	bit 27 set	3	2
Float RTK	bit 28 set	2	3
Wide Lane RTK	bit 29 set	1	4
Narrow Lane RTK	bit 30 set	0	5

For **tightly coupled solution** bits 12 to 17 of status word C define the solution mode:

Condition	POS MV flag	POS MV code	Std. code
No Solution	no bit set	7	0
Stand-alone	bit 12 set	5	1
RTCM DGPS	bit 13 set	4	2
Code DGPS	bit 14 set	3	2
Float RTK	bit 15 set	2	3
Wide Lane RTK	bit 16 set	1	4
Narrow Lane RTK	bit 17 set	0	5

The POS MV code is recorded in the HYPACK QUA message as the 4th value. Starting with version 6.8 of the driver the standardized code is recorded in the HYPACK QUA message as the 1st value (replacing the unused 10-dop value).

BUFFER VS MESSAGE SIZE

Data recorded with "Log Device Messages" option is sometimes longer than the buffer set aside by SURVEY (256 characters). Version 10.0.5.6 truncates the data to the size allocated by SURVEY but would be nice to increase the buffer size in SURVEY.

SBG.DLL

Version Number: 17.0

Device Name: SBG Equinox INS

DEVICE SETUP

Position: Logs position data from this device.

Heading: Logs heading data from this device.

SURVEY uses the Course Made Good from the VTG, RMC or HDT message, or calculates the vessel orientation based on the change in position over time.

Speed: Displays speed data from this device.

Heave: Logs heave, pitch and roll data from this device.

Record Raw Messages: Logs the data string to the raw file as it is originally received from the device.

Record Raw Data: Records Lat./Lon. (in dec. degrees), antenna height above ellipsoid, UTC time to RAW records.

Record Quality Data: Logs data indicative of the positioning accuracy. QUA records include HDOP, Number of Satellites and GPS Mode, which can be used in post-processing to filter data with sub-standard positioning.

DRIVER SETUP

FIGURE 1. Driver Setup

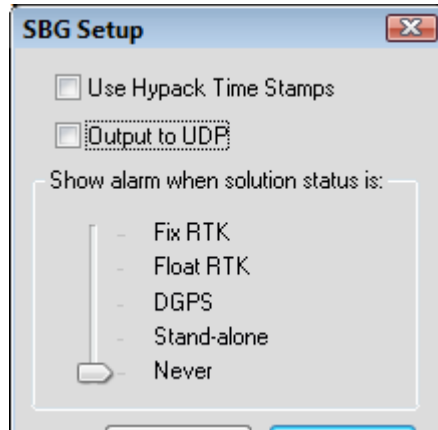

Use Hypack Time Stamps: Takes timestamp from the HYPACK® computer rather than the stamp from the Equinox. With most navigation systems, it has become common practice to use the time stamps from the system. You can override this by checking the box in Setup.

Output to UDP: Passes data to both HYPACK® SURVEY and HYSWEEP® SURVEY through UDP port 5656.

Show Alarm when Solution is: HYPACK® SURVEY shows an alarm when the GPS drops below the selected GPS mode.

DEVICE OUTPUT STRINGS

In the Output page of the SBG software, configure the output as follows:

TABLE 1. Output Strings for HYPACK® Configuration

Log	Output	Rate	Info Decoded by HYPACK®
EKF Euler	Continuous	50 Hz.	Heading, Pitch Roll
EKF Nav	Continuous	10-50 Hz.	Position
Heave 0	Continuous	50 Hz.	Heave
UTC	New Data	N/A	Time
GPS1 Position	Continuous	10-50 Hz.	Status Codes, Sigma Values

It is important to set your **EKF Euler** and **Heave 0** Log outputs at 50 Hz. The data rates of the 2 logs are slightly different and,

because we combine heave, pitch and roll in the same “HCP” record, we want to have the timing logged correctly!

EKF Nav and **GPS1 Position** can be set anywhere from 10 Hz to 50 Hz. (No need for anything faster.)

DRIVER OUTPUT

DEVICE WINDOW

- The driver writes the most current GPS data to a spreadsheet.
- If you have an RTK GPS, it includes the values used to calculate RTK tides.
- Reports GPS Quality using standardized coding and sends them to Shared Memory for HYSWEEP®.

FIGURE 2. Device Window in HYPACK® SURVEY

Parameter	Value
Mode	2 - Single point solution
WGS84 Lat	41°35.6148 N
WGS84 Lon	072°43.4226 W
WGS84 Height	11.53m
Lat	41°35.6148 N
Lon	072°43.4226 W
Ell. Height	11.53m
Easting	1007191.34
Northing	777008.13
Sigma N	2.8696
Sigma E	2.2081
Sigma Z	5.9163
A=WGS84 Height	37.84ftUS
H=Z Offset	0.00ftUS
D=Draft	0.00ftUS
K-N=Ell. Height above CD	-0.00ftUS
Tide corr.	-37.84ftUS
Time Source	SBG
Hdg	348.1°
Pitch	-0.4°
Roll	-1.0°
Heave	0.00ftUS
Elevation	37.84ftUS

PORT

The serial string can be packaged into a UDP packet for both HYPACK® SURVEY and HYSWEEP®.

SPECIAL NOTES

Reports GPS quality using standardized codes.

CONNECTION INFORMATION

Connect to the proper Ethernet Port as shown in the following figure:

FIGURE 3. Configuring Ethernet Device Connection

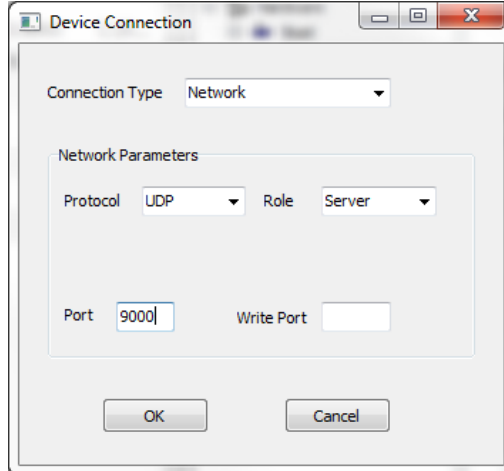

Offsets should be relative to the vessel center of gravity.

HYSWEEP® SURVEY CONFIGURATION

Add HYSWEEP®'s “SBG Systems” driver.

- Under **Setup** you can use one of these down sampling options. It is recommended to use the default 50 Hz logging rate.

FIGURE 4. HYSWEEP® Setup for the SBG Systems Driver

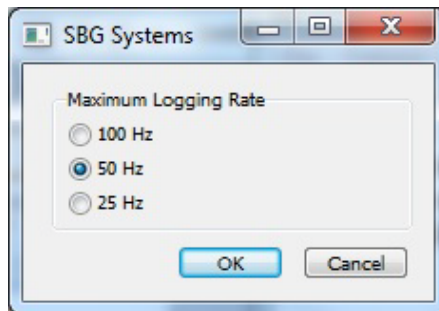

- **Connect** to the proper Ethernet Port as shown in the following figure:

FIGURE 5. *Configuring the HYSWEEP® Connections*

Enabled Ignore Checksum Timeout Interval (Seconds)
 Record Raw Messages

Network Connection

Port
Internet Address

- **Offsets** should be relative to the vessel center of gravity.

SSB.DLL

Version Number: 14.0.0.3

Device Name: SSB (NMEA) Position Device

DEVICE SETUP

Position: Logs position data from this device.

Depth: Logs soundings or magnetometer data from this device.

Heading: Logs heading data from this device.

Speed: Displays speed data from this device.

Use for matrix update: Color-codes a matrix based on the data received from this device.

DRIVER SETUP

FIGURE 1. Driver Setup

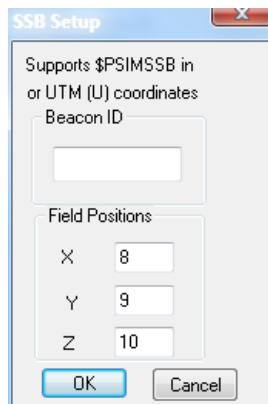

Beacon ID: Enter the number of the beacon to be read. The driver ignores any messages with Beacon ID other than the one specified in the setup. If you leave the Beacon ID blank, it will read all \$PSIMSSB messages.

Field Positions of X, Y and Z:

DEVICE OUTPUT STRINGS

String known as 'SSB', 'HiPAP' and 'HPR'. The driver requires the coordinate system in Cartesian or UTM format.

```
$PSIMSSB, time, beaconID, status, error_code,  
coordinate_system, orientation, sw_filter, x_coordinate,  
y_coordinate, depth, expected_accuracy, additional_info,  
first_add_value, second_add_value, checksum, termination  
<CR><LF>
```

```
$PSIMSSB, 130656.05, B48, A, Mi2, C, H, F, 0.67, 2.59, 1.69, 0.46, N<CR>  
<LF>
```

DRIVER OUTPUT STRINGS

DEVICE WINDOW:

Writes the original string.

Formats depth, X and Y to 2 decimals and writes:

```
x=X y=Y dpt=Depth
```

SPECIAL NOTES

KNOWN SUPPORTED DEVICES

- Most Kongsberg HiPAP and HPR systems
- Sonardyne USBL
- AAE Easytrak USBL system

TOWFISH.DLL

The Towfish driver is a cable count device driver that calculates the approximate positioning of towed devices.

Version Number: 17.1.1

Device Name: Towed Sonar Layback

DEVICE SETUP

Position: Logs position data from this device.

Heading: Logs heading data from this device.

SURVEY uses the Course Made Good from the VTG, RMC or HDT message, or calculates the vessel orientation based on the change in position over time.

Generate Output Messages: Generates messages or data outside of the Raw file.

Record device specific messages: Logs additional data related to the device to the Raw file. Each record will be identified by a driver-specific, 3-character tag.

The Towfish driver records CAB strings. See Driver Output.

DRIVER SETUP

STANDARD TAB

FIGURE 1. Driver Setup

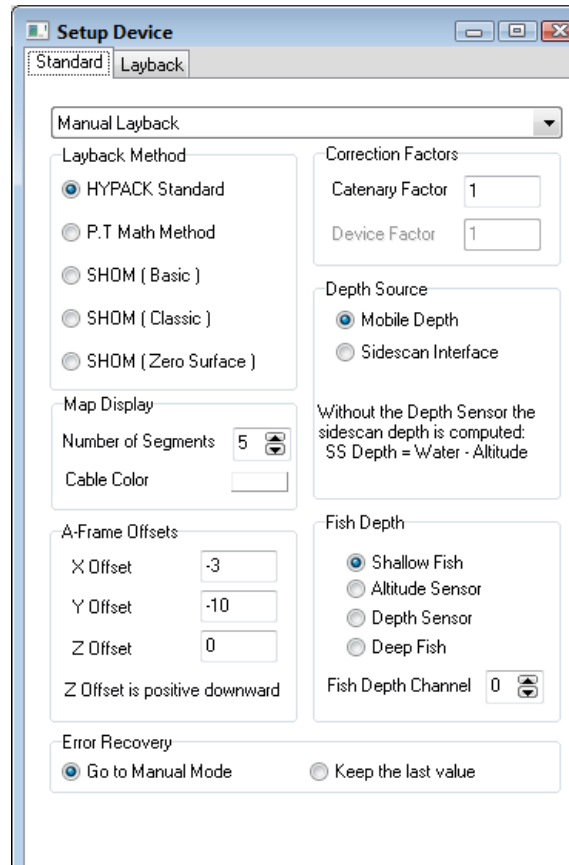

Input Type: Specifies manual or an automated cable counter.

- **Manual** enables you to change the length of the cable manually in SURVEY.
- **If you are using the other devices**, it will send your cable count value automatically. In either case, HYPACK® will calculate the layback.

Layback Method:

FIGURE 2. Layback Diagram

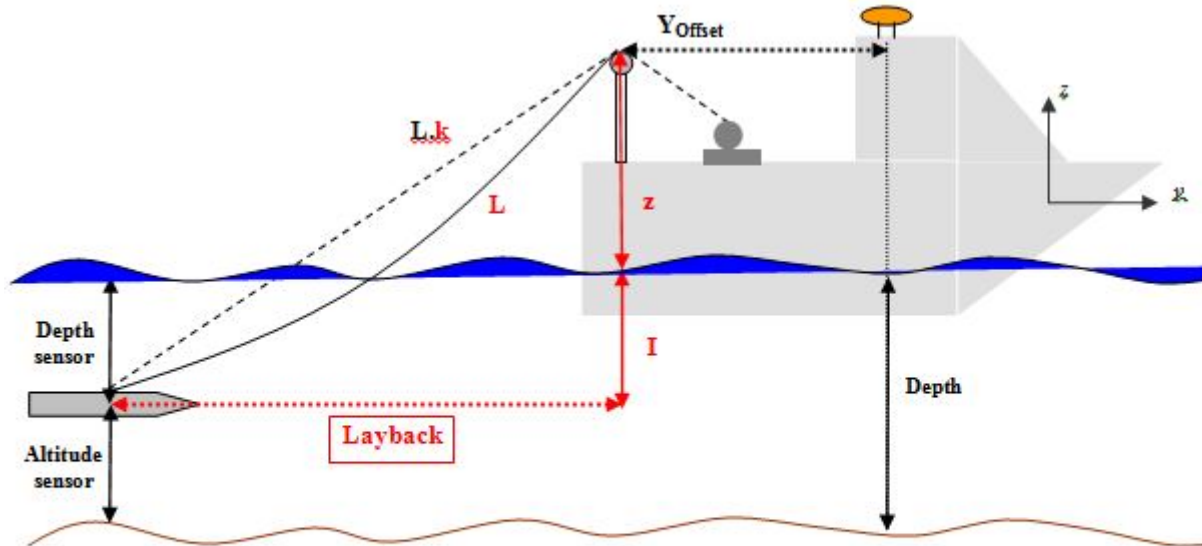

L = cable out

k = catenary factor

I = Depth sensor or (Depth - Altitude sensor)

z = Offset pulley (A-Frame offset)

- **HYPACK® Standard:** $Layback = \sqrt{(k \cdot L)^2 - (I + z)^2}$
- **PT (Pythagorean Theorem) Math:** Accounts for cable out from the winch to the sheave. When this option is selected, additional options appear in the dialog.
 - **GPS to Winch Distance (Y Offset)**
 - **Winch to Sheave Distance:** Horizontal distance.
 - **Sheave Height:** z
 - **Winch Height** from the waterline.
- **SHOM Options:** These are three custom calculation methods. The values are represented in the diagram above.
 - **SHOM Basic:** $Layback = k \cdot L$
 - **SHOM Classic:** $Layback = \sqrt{(k \cdot L)^2 - (I + z)^2}$
 - **SHOM Zero Surface:** $Layback = \sqrt{(k(L + z))^2 - (I + z)^2}$

A-frame Offsets:

- The **X-offset** is the distance from the boat origin to the attachment point on the A-frame. It is positive when the A-frame is starboard of reference point.

NOTE: This is the same as the Starboard offset in the device setup. Use either one, but not both.

- The **Y-offset** is the distance from the boat origin to the attachment point on the A-frame. It is negative (as usual) when the A-frame is astern of reference point.

NOTE: This is the same as the Forward offset in the device setup. Use either one, but not both.

- The **Z-offset** is the height of the A-frame above the water. It is positive when the A-frame is above the water. (It is cumbersome to place the A-frame under water.)

NOTE: This would be the same as the Height offset in the Offsets dialog. It is important to enter this value in the Driver Setup dialog as it is used in the calculations with the catenary factor. Leave the Height Offset in the device setup at zero.

Correction Factors:

- **Catenary Factor:** A multiplier that accounts for the slack in the tow cable. For Shallow Fish, the default is 0.81; for Deep Fish, the default is 0.63; for Altitude Fish, the catenary factor changes with the fish altitude.
- **Device Factor** is enabled only if you have selected the Redlion or Remontec Input option. The driver multiplies the layback value read from the device by this factor before recording the final value.

Depth Source:

- **Mobile Depth:** Depth as determined by the 'Fish Depth' option.
- **Side Scan Interface:** Side Scan with bottom-tracking stores the fish altitude to shared memory where the towfish can read it and use it in the layback calculations. This eliminates the need for Hysweep.dll to pass these values from SIDE SCAN SURVEY to HYPACK® SURVEY.

Fish depth: There are four methods for determining fish depth, each one has a little different requirements.

- **Shallow fish:** The fish depth is always 0.
- **Altitude Sensor:** Some side scan sonars provide the fish altitude above the bottom. Configure another echosounder device to provide this information. You also must have a

second echosounder that provides water depth for the boat. The cable counter driver calculates the fish depth as the difference between the water depth under the boat and the fish altitude (assuming the bottom is flat).

- **Depth Sensor:** The fish is fitted with a pressure transducer that directly outputs the fish depth. You have to interface this device using any of the available echosounder drivers. (Try using the generic one, leaving the offset values at 0.) You must also configure the mobile associated with the fish to use that device as depth sensor.
- **Deep fish:** Your fish is extremely heavy and hangs straight under the A-frame. In this case, the layback is always equal to Y-offset.

Fish Depth Channel: Set the depth channel when you are not using a shallow fish.

Error Recovery: If you are using an electronic cable counter and the driver stops receiving updates (for example, due to power outage), it can do one of two things until the updates resume from the cable counter:

- **Go To Manual Mode** reverts to the layback value entered in SURVEY.
- **Keep Last Value** retains the last value read from the cable counter.

Number of Segments: More segments in the length of the cable enables smoother curves.

Cable Color: The display color of the cable in the HYPACK® SURVEY Area Window. To change the color, click on the color bar and select a new color from the colors dialog. You can set a different color for each towfish.dll (mobile) in your configuration.

DEVICE OUTPUT STRINGS

We are only concerned about the actual cable payout, and this should be set to your working survey units in the system. The cable output value is bolded and the underscores are spaces.

TABLE 1. Cable Count Devices and Expected Output Strings

Device	Output String
AGO EWC-4A	\$YXXDR,D, 301.2 ,M,L,S,30.0,M,R*24
Bot Metering Sheave	n/a (complicated series of parsers and commands)
CM2 Counting Pulley	String n/a. Pulls from the window of the counter program
Dynapar	R:_CO.____ 13

Device	Output String
LCI-90 Protocol 1	RD,05.14621,00000000, 03.04801 ,1509
LCI-90 Protocol 2	**00__1204.4_0__ 51.004 _0___49.3_0
MacArtney	L= 100.00 m<lf>S=10.0 m/min.<lf>
MDTOTCO	01,____60,_,____ 196 ,_,____-33,_,0000
PI5600	_____+0000 _ 0.000 METERS
SCC Smart Cable Counter (Hydrographic Survey Products)	\$CCB 00105.0F +0563
SD-41 Counter	01,___-1988,_,____ 12.0 ,_,____133,_,0000
Seamac	-1??_ 0015 .
SeaRobotics Counter	100.0
Redlion	"_____ 1332 "
Remontec TCount	1: 0025

DRIVER OUTPUT STRINGS

Record Device Specific Messages function logs CAB strings to the Raw file:

TABLE 2. CAB String

Format	CAB	dn	t	n	Cable	Lay	Cat	SDep	Dep	SAIt	
Where	dn	device number									
	t	time tag (seconds past midnight)									
	n	number of values to follow									
	Cable	Cable Out									
	Lay	Layback									
	SDep	Sensor Depth									
	Dep	Water Depth									
	SAIt	Sensor Altitude									
Sample Line	CAB	2	27537.345	6	100.000	100.000	1.000	0.000	70.000	70.000	

DEVICE WINDOW

In the toolbar of the Device window, you can modify the catenary factor, cable out and cable adjustment values in real time during SURVEY.

To change the **Catenary Factor**, enter the new value and click [Set Catenary Factor].

FIGURE 3. Device Window - Display

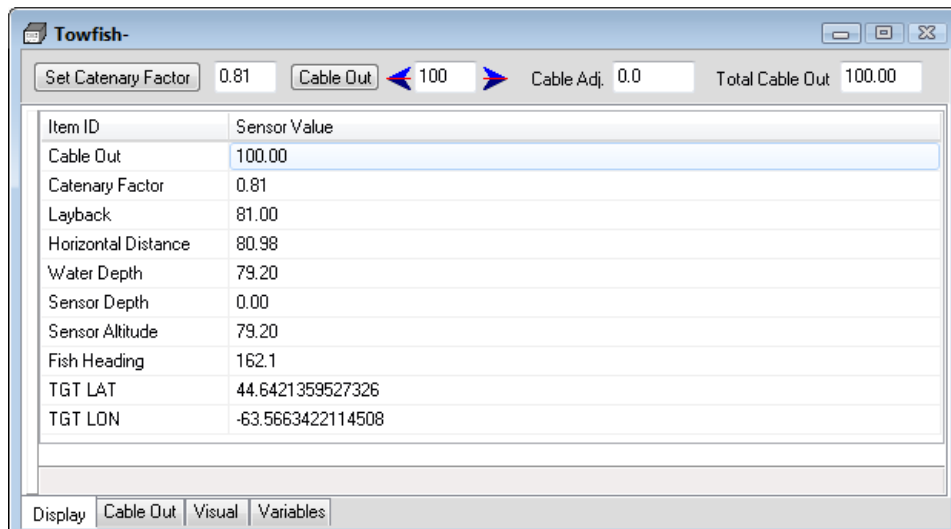

The Visual display shows the bottom based on “boat” echosounder depths and timed based on speed of the boat to estimate fish altitude.

$$(EQ 1) \quad \text{EchoDepth} - \text{FishDepth} = \text{FishAltitude}$$

FIGURE 4. Device Window - Visual

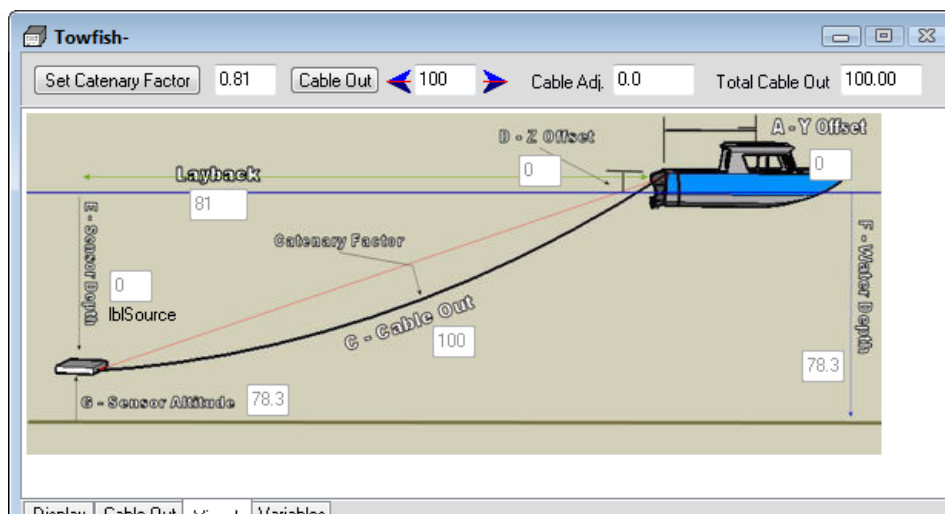

The Variables tab shows some additional factors used in the calculations.

FIGURE 5. Device Window - Variables

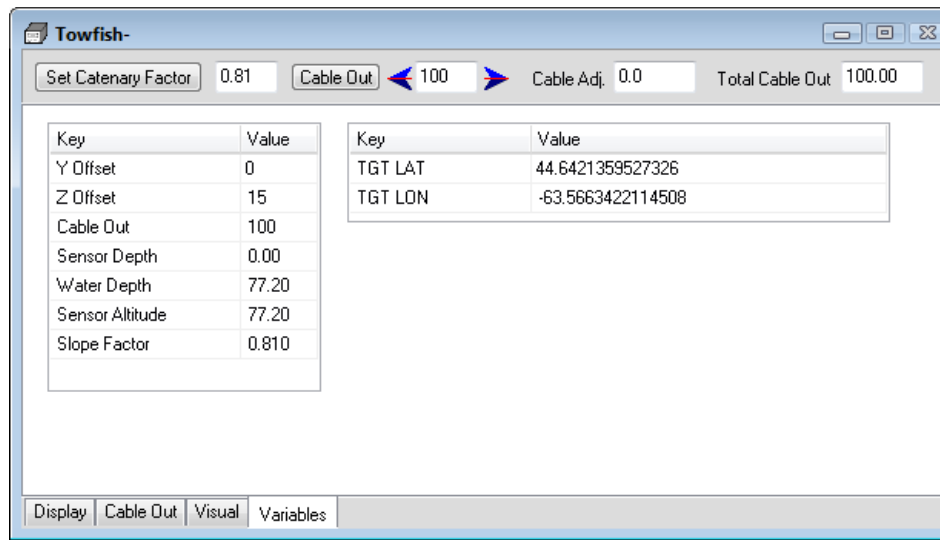

DEVICE SPECIFIC MESSAGE

TABLE 3. CAB String

Format	CAB dn t n Cable Lay Cat SDep Dep SAIt	
Where	dn	device number
	t	time tag (seconds past midnight)
	n	number of values to follow
	Cable	Cable Out
	Lay	Layback
	Cat	Rough Catenary Factor
	SDep	Sensor Depth
	Dep	Water Depth
	SAIt	Sensor Altitude
Sample Line	CAB 2 27537.345 6 100.000 100.000 1.000 0.000 70.000 70.000	

SPECIAL NOTES

OFFSETS

All should be zero in the Survey Connect tab. They are set in the Driver Setup dialog.

TOWFISH_SIMPLE.DLL

Version Number: 17.0.2

Device Name: Towfish, Simple

DEVICE SETUP

Position: Logs position data from this device.

Heading: Logs heading data from this device.

Generate Output Messages: Generates messages or data outside of the Raw file.

Record device specific messages: Logs additional data related to the device to the Raw file. Each record will be identified by a driver-specific, 3-character tag.

The Towfish driver records CAB strings. See Driver Output.

DRIVER SETUP

FIGURE 1. Driver Setup

The screenshot shows the "Setup Device" dialog box with the following settings:

- Fixed Layback
 - X (Stbd): 0.00 m
 - Y (Fwd): 0.00 m
- Variable Layback
 - GPS to Cable Counter
 - X (Stbd): 0.00 m
 - Y (Fwd): 0.00 m
 - Z (Vert): 0.00 m
 - Z is the vertical distance from the water surface to the cable counter. This number should be negative.
 - Depth of Sonar
 - Manual: 0.00 m
 - Read from Sub-Bottom
 - Ignore
 - Initial Cable Out: 0.00 m
 - Catenary Factor: 0.9
 - Cable Multiplier: 1

Cable Out Source: Manual Layback (dropdown menu)

Cable Connection: [Empty text box]

Buttons: OK, Cancel

- **Fixed Layback:** For hull-mounted sonars or for short tows where the distance of the sonar array from the GPS antenna does not change, the towfish moves as if it is directly mounted on the boat.

Enter the distances, port and starboard from the GPS to the sonar.

- **Variable Layback:** The layback is calculated based on cable out and, in most cases, sonar depth. This is a more advanced setup:
 - **GPS to Cable Counter:**
 - The **X-offset** is the distance from the boat origin to the attachment point on the A-frame. It is positive when the A-frame is starboard of reference point.
 - The **Y-offset** is the distance from the boat origin to the attachment point on the A-frame. It is negative (as usual) when the A-frame is astern of reference point.
 - The **Z-offset** is the height of the A-frame above the water. It is positive when the A-frame is above the water. (It is cumbersome to place the A-frame under water.)
 - **GPS to Cable Counter:** The offsets from the GPS antenna to the cable counter (where cable is fed from the boat).
 - **Depth of Sensor:**
 - **Manual:** Towfish depth entered in the HYPACK® SURVEY interface.
 - **Read from Sub-bottom:** Towfish depth read from the device.
 - **Ignore:** SURVEY assumes the towfish is on the water surface,
 - **Cable Out Source:** The cable out can be manually entered (and adjusted during SURVEY) or it can be read from an industry cable counter. The following cable counters are currently supported:
 - AGO EWC-4A
 - BOT Metering sheave
 - Dynapar
 - MDTOTCO
 - Redlion
 - CM2 Counting Pulley
 - LCI 80
 - LCI-90 Protocol 1
 - LCI-90 Protocol 2
 - MacArtney
 - Marine Search
 - PI 5600
 - SCC Smart Cable Counter
 - Seamac
 - Remontec TCount
 - Sea Robotics Counter
 - SD-41 Counter
 - **Initial Cable Out:** Amount of cable extended before the cable counter reports.

- **Catenary Factor** multiplier accounts for the water dragging on the cable.
- **Cable Multiplier:** Multiplies the cable length by the user-defined amount.

To connect a cable counter, select your model cable counter from the drop-down then click the [Cable Out Setup] to configure the connection information.

DEVICE OUTPUT STRINGS

We are only concerned about the actual cable payout, and this should be set to your working survey units in the system. The cable output value is bolded and the underscores are spaces.

TABLE 1. Cable Count Devices and Expected Output Strings

Device	Output String
AGO EWC-4A	\$YXXDR,D, 301.2 ,M,L,S,30.0,M,R*24
Bot Metering Sheave	n/a (complicated series of parsers and commands)
CM2 Counting Pulley	String n/a. Pulls from the window of the counter program
Dynapar	R:_CO.____ 13
LCI-90 Protocol 1	RD,05.14621,00000000, 03.04801 ,1509
LCI-90 Protocol 2	**00__1204.4_0_ 51.004 _0____49.3_0
MacArtney	L= 100.00 m<lf>S=10.0 m/min.<lf>
MDTOTCO	01,____60,_,____ 196 ,_,____-33,_,0000
PI5600	_____+0000_ 0.000 METERS
SCC Smart Cable Counter (Hydrographic Survey Products)	\$CCB 00105.0F +0563
SD-41 Counter	01,___-1988,_,____ 12.0 ,_,____133,_,0000
Seamac	-1??_ 0015 .
SeaRobotics Counter	100.0
Redlion	"_____ 1332 "
Remontec TCount	1: 0025

DRIVER OUTPUT

Records CAB strings to the RAW file:

TABLE 2. CAB String

Format	CAB	dn	t	n	Cable	Lay	Cat	SDep	Dep	SAlt	
Where	dn	device number									
	t	time tag (seconds past midnight)									
	n	number of values to follow									
	Cable	Cable Out									
	Lay	Layback									
	Cat	Rough Catenary Factor									
	SDep	Sensor Depth									
	Dep	Water Depth									
	SAlt	Sensor Altitude									
Sample Line	CAB 2 27537.345 6 100.000 100.000 1.000 0.000 70.000 70.000										

DEVICE WINDOW

Display shows the bottom based on “boat” echosounder depths and timed based on speed of the bot to estimate fish altitude.

$$(EQ 1) \quad \text{EchoDepth} - \text{FishDepth} = \text{FishAltitude}$$

SPECIAL NOTES

OFFSETS

All should be zero in the Survey Connect tab. They are set in the Driver Setup dialog.

TRACKMAN.DLL

Version Number: 13.0.10.14

Device Name: TrackMan Interface

DEVICE SETUP

Position: Logs position data from this device.

Heading: Logs heading data from this device.

Record Raw Messages: Logs the data string to the raw file as it is originally received from the device.

DRIVER SETUP

FIGURE 1. Driver Setup

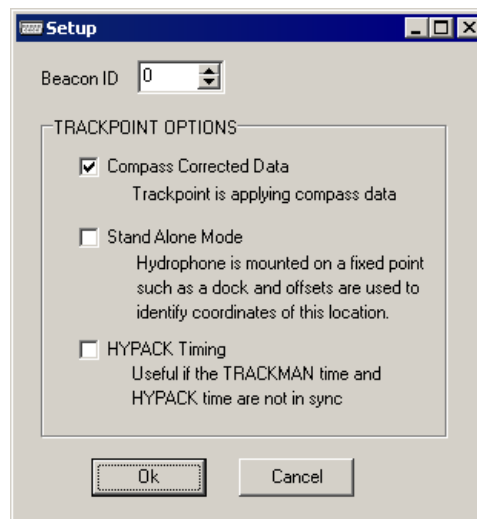

Beacon ID: Beacon number, which will be tracked on the screen. The current version of HYPACK® supports only a single beacon from the TrackPoint system, however you may install the Trackman.dll multiple times.

- **Using COM Ports:** Assign each instance of the driver to a different COM port and Target Number, to track up to 10 devices.

- **Using UDP Ports:** A different Beacon ID is used in each instance of the driver, but the same UDP port number can be used as multiple drivers can read from the same UDP port.

Trackpoint Options:

- **Compass Corrected Data:** (Typically checked.) A compass is connected to the TrackPoint and the bearing received from the TrackPoint is already corrected with the boat heading. If you cannot connect your gyro to the TrackPoint system, HYPACK® will use the heading of your vessel to correct the bearing received from the TrackPoint
- **Stand-Alone Mode** is only used for dock-side testing and should not be used for survey purposes. The coordinates of the dock are entered as the STARBOARD and FORWARD offsets. By entering the coordinates in the offsets, the driver adds the TrackPoint reading to report the position of the beacon.
- **HYPACK Timing:** The program uses the time tag of the message as it is received by the HYPACK® software. With this unchecked the HYPACK® program decodes the time in the \$POREG message (received from the TrackPoint software) and applies this to the HYPACK® data.

DEVICE OUTPUT STRINGS

\$POREG string. Proprietary output from TrackPoint software.

```
$POREG,01,180259.00,0000,0000,0000,10,50,,00.00,000.00,000  
000.10,000000.10,00368.90,,000.03,000.00,012,000.0*57
```

In addition to a serial output, the TrackPoint software is capable of outputting this message via Ethernet broadcast, thus eliminating the need for a serial port.

DRIVER OUTPUT STRINGS

DEVICE WINDOW:

Tabbed interface.

The **Tracking Data tab** updates the following values in real time:

- Transponder ID
- Time
- PHSA
- PHSB
- PHSC
- QF
- EC
- Slant Range
- DPA
- Bearing
- X
- Y
- Z
- Heading
- Pitch
- Roll
- TMP
- Trackman Time
- HYPACK® Time
- Time Difference

The **Raw Data tab** writes the raw data strings in a scrolling display.

SPECIAL NOTES

- Uses either Serial or Network connections.
- Reverse the signs of the forward and starboard offsets in the device setup. (Forward and starboard measurements should be negative.)

KNOWN SUPPORTED DEVICES

ORE Trackpoint 3

TRACKP.DLL

Version Number: 13.0.1.5

Device Name: Trackpoint II ROV Acoustic System

DEVICE SETUP

Position: Logs position data from this device.

Depth: Logs soundings or magnetometer data from this device.

Use for matrix update: Color-codes a matrix based on the data received from this device.

Record Raw Messages: Logs the data string to the raw file as it is originally received from the device.

DRIVER SETUP

FIGURE 1. Driver Setup

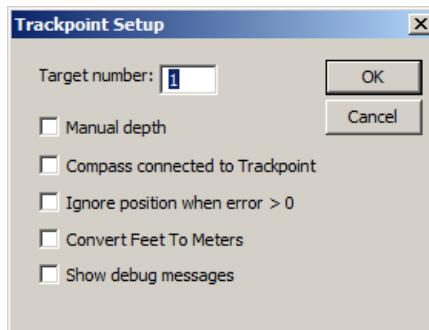

The **Target Number** is the beacon number, which will be tracked on the screen. The current version of HYPACK® supports only a single beacon from the TrackPoint system, however you may install the Trackpoint.dll multiple times, each to a different COM port and Target Number, to track up to 10 devices.

Manual Depth is used to improve the position computation. If this value is checked, the program will pass the depth information from the SURVEY program to the TrackPoint system. It works best if the depth is determined from a pressure transducer on the ROV. The depth device must be set up as a separate device in the HARDWARE program.

Compass Connected to Trackpoint (typically checked) tells the program that the bearing received from the TrackPoint is already corrected with the boat heading. If you cannot connect your gyro to the TrackPoint system, HYPACK® will use the heading of your vessel to correct the bearing received from the TrackPoint.

Ignore Position When Error>0 provides the option to accept or reject questionable sounding data. Certain readings are coded by the TrackPoint system as questionably accurate. Checking this box rejects this suspect data from being saved.

Convert Feet to Meters divides relative X, Y and Z by 3.28.

Show Debug Messages: Replaces table with rolling display of data useful to driver programmers.

DEVICE OUTPUT STRINGS

2EC string:

BeaconID Time Heading Bearing S.R.(m) X(m) Y(m) Z (m) Tel Warn:

```
1 12:24:23 199 20.5 124.7 40.9 109.5 16.0 0.0  
(We read BeaconID, X, Y, Z.)
```

DRIVER OUTPUT STRINGS

DEVICE WINDOW:

FIGURE 2. Sample Device Window

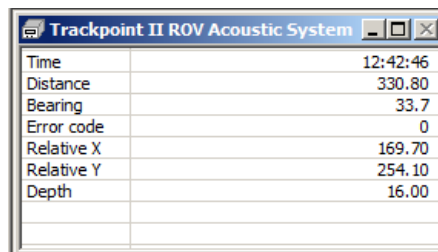

Trackpoint II ROV Acoustic System	
Time	12:42:46
Distance	330.80
Bearing	33.7
Error code	0
Relative X	169.70
Relative Y	254.10
Depth	16.00

Shows a table with real-time values for Time, Distance, Bearing, Error Code, Relative X and Y, and Depth.

SPECIAL NOTES

Reverse the signs of the forward and starboard offsets in the device tab. (Forward and starboard measurements should be negative.)

KNOWN SUPPORTED DEVICES:

You can use this driver with the following USBL systems:

- **ORE Trackpoint 2** – Select the 2EC output
- **LinkQuest Tracklink Systems** – Select the “TP2” output string.
- **Sonardyne USBL systems** – Select Trackpoint 2 string
- **AAE Easytrak** – Select the Trackpoint 2EC string

Echosounders

•

Echosounder Types

Echosounders are devices that measure depth. They come in several varieties. These include single beam systems, dual frequency systems, multiple transducer systems and multibeam systems.

Single Beam Echosounder Systems: Single Beam Systems measure a single depth below the echosounder transducer. There are over twenty different single beam echosounders that have been integrated into HYPACK®. The integration is usually straightforward.

Single frequency systems store data in the survey program as **EC1 Records**. These records contain the Device Number, the Time Tag and the Depth received from the echo. Single beam echosounder data is edited in the SINGLE BEAM EDITOR.

Dual Frequency Echosounder Systems: Dual frequency systems provide depth measurements from two transducers and report them over a single interface. Typically, you have a high frequency and low frequency transducer connected. HYPACK® can support over ten different dual frequency systems. During the SURVEY program, you will see two depths in the CHART DISPLAY window. During the editing process, you will see both frequency transducers and can edit them simultaneously. The ALL format has room for two separate depth values. When you create a final product, whether it is plotting a smooth sheet, exporting depths or creating TIN models, you must decide whether to use the high or low frequency values. Since there is minimal separation between the two transducers, you only need to specify a single offset value when specifying the offset values in the HARDWARE program.

Dual frequency systems store data in the SURVEY program as **EC2 Records**. These records contain the Device Number, the Time Tag, and the High and Low Frequency Depths. The high frequency depth is normally configured as “Depth 1” and the low frequency depth is “Depth 2”. You can set up some echosounders so this is reversed. Dual frequency data is edited in the SINGLE BEAM EDITOR.

Multiple Transducer System: A Multiple Transducer System may have from three to thirty-two transducers arrayed in a line on the vessel. The offsets for each transducer are specified in the Offsets tab of HYSWEEP® HARDWARE. This information is appended to the header of all RAW data files that use multiple transducer systems.

HYPACK® can collect data from these types of systems and store it in **ECM Records**. These records contain the Device Number, the

Number of Transducers and the Measured Depth For Each Transducer. This data can only be edited in the multibeam processors.

Multibeam Systems: A Multibeam System takes from thirty to sixty depth measurements at constant angles every update. This data is logged as **SB2** Records in the Raw data file. Each record contains the Device Number, the Number Of Data Records that follow, the Multibeam Measurement Information for each beam and the Multibeam Quality Information for each measurement.

You can also use the Hysweep.dll to pass the nadir depth to HYPACK® SURVEY where it will be stored as an EC1 record. This is done by checking Depth in the device setup dialog.

Data from multibeam surveys can only be processed in the 32-bit HYSWEEP® EDITOR or 64-bit HYSWEEP® EDITOR.

Seabed ID Systems: Certain echosounders record two echo return values (E1 and E2) in addition to the depth. These values vary according to the roughness and hardness of the bottom composition. This enables you to define various bottom types by a specific range of E1 and E2 values from the echosounder.

The SeabedID device driver refers to a user-defined table of E1-E2 ranges and bottom classifications—the Seabed ID Square—to assign a Seabed ID number for each sounding record during SURVEY. The E1 and E2 values are time tagged saved with the Seabed ID number to an ROX record in the raw data file. If this driver is used to paint the matrix, SURVEY will fill the matrix using Seabed ID colors based on the Seabed Square created in SEABED STATISTICS for your survey area and designated in the driver setup.

To do all of this requires a little preparation:

1. **Do your bottom truthing** in your survey area to determine the echo return values that correspond with each bottom type in your area.
2. **Use SEABED STATISTICS to create a Seabed ID Square.** This (*.SIX) file contains the classifications for your project area and their corresponding E1 and E2 ranges.
3. **Use the SeabedID device driver (SeabedID.dll) in your Hardware Setup,** specifying your Seabed ID Square (*.SIX) in the Driver Setup dialog.

NOTE: You can log data with no SIX file specified in the driver setup, but no Seabed IDs will be logged in the RAW data. In this case, when you have a SIX file, you can assign the

Seabed ID in either the RAW or edited ALL format files using the SEABED STATISTICS program.

Sub-bottom Profilers

Sub-bottom profilers have two transducers using different low-frequency pings to sound the bottom. They are different than dual frequency sounders in that:

- The frequencies used are much lower, which provides greater penetration of the softer, surface sedimentation.
- Depth soundings are not survey quality.

Configure the device in HARDWARE with the subbot.dll. HYPACK® records a pair of data files for each line—a raw file and a SEG-Y file.

In SURVEY, the subbot device window shows the latest signal and a scrolling history. You can configure the subbot driver device window to display one panel for *either* frequency or two panels--one for *each* frequency. Each panel may also include a vertical grid at user-defined intervals and the bottom track, as well as event markers.

FIGURE 1. Configuring the Subbot Device Window

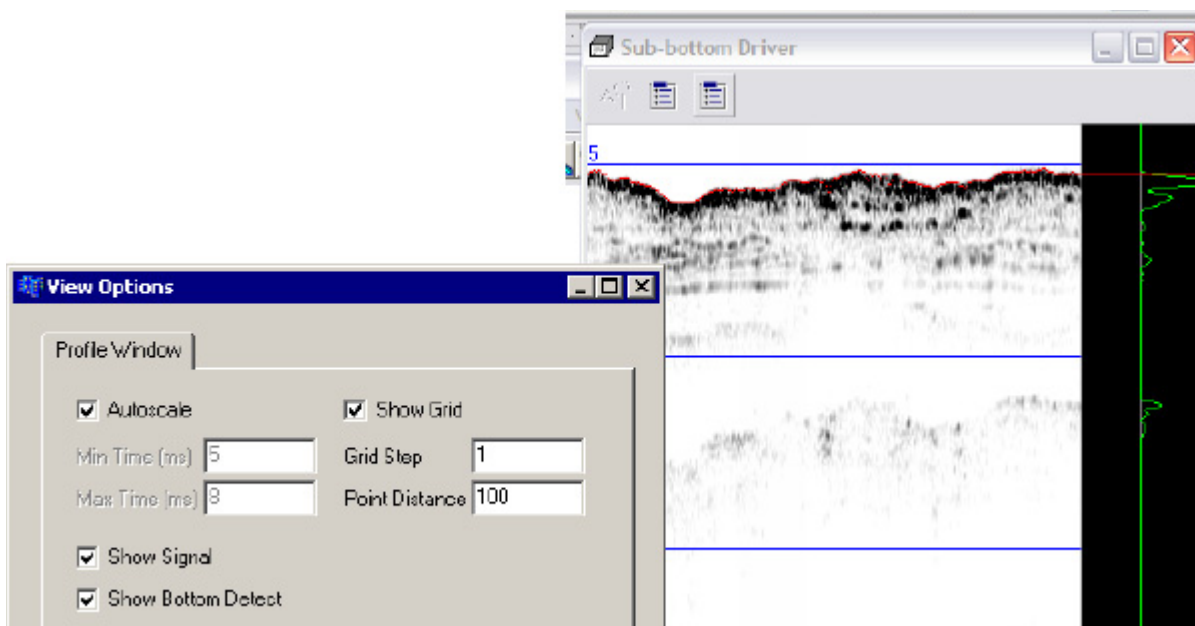

Filter and Gain Controls provide flat gain, FFT band pass filtering and several color palette options.

FIGURE 2. Filter and Gain Controls

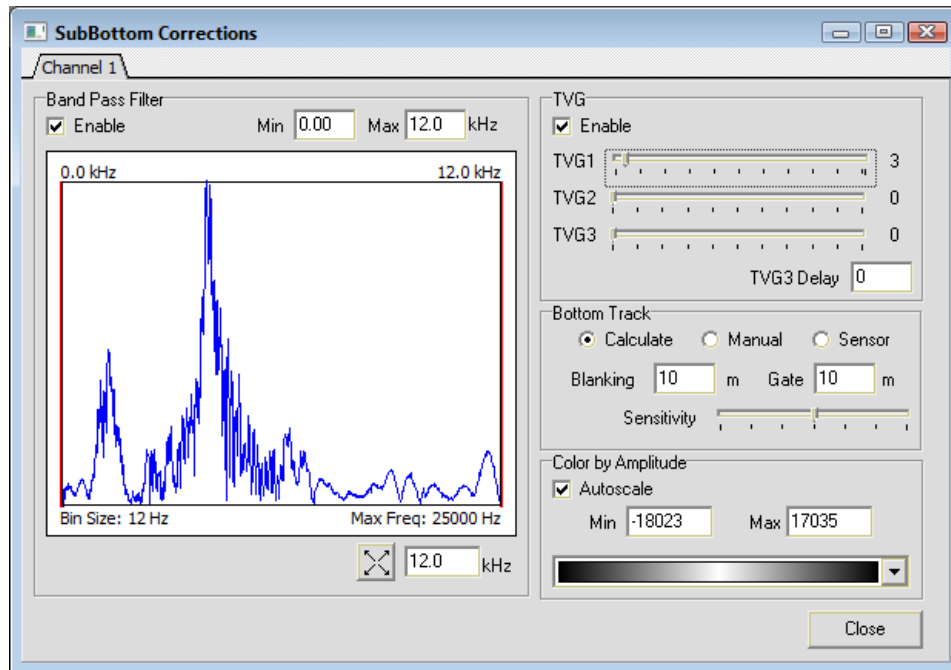

If you are using an analog device, the triggering mode, interval, sample period and delay are configured in the Analog Settings dialog which is accessed from the device window.

FIGURE 3. Analog Settings

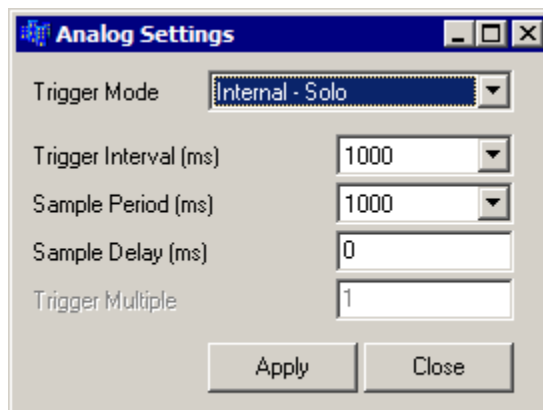

At any time you may take screen captures or print either display. Data collected with the subbot.dll can be loaded to the SUB-BOTTOM PROCESSOR. There you can mark targets and digitize your layers.

When you mark targets in the SUB-BOTTOM PROCESSOR they are saved to a target file named using the date and time derived from its position in your data.

Each digitized layer is saved to an All format file, which can then be displayed and plotted in CROSS SECTIONS AND VOLUMES.

Annotation and Event Marks

An **event mark** is a line drawn across the echosounder chart at your specified intervals. In HYPACK® these intervals can be based on Distance Traveled (based on the track line) or Time Elapsed. The event increment is specified in the NAVIGATION PARAMETERS menu of the SURVEY program. If your echosounder has event mark and annotation capability, the device driver will normally take care of these functions. Some of the device drivers require you to select the Annotation option in the SETUP window.

Sending a character to the echosounder triggers most event marks. The echosounder draws a solid line across the chart on the next update cycle. Annotation is treated differently on various echosounders. On some sounders, the echosounder has to go into “annotation mode”. It stops taking soundings and transmitting records until the annotation has been printed. This is the reason some users find “gaps” in their sounding data just after event marks.

The annotation strings are “fixed” and cannot be changed. What you see is what you get. If you desire a different annotation string, you can contract with HYPACK to custom tailor the device driver to send the exact string you desire.

Calibration

Depth sent to the computer is sum of the measured depth from the transducer to the bottom transducer and the static draft correction.

The ‘Static Draft’ represents the vertical offset of the transducer beneath the static waterline. ‘Static’ refers to the fact that the vessel is not moving.

FIGURE 4. *Static Draft*

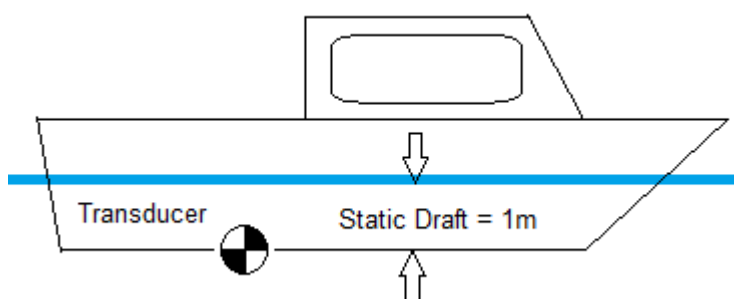

In HYPACK®, Static Draft (and Dynamic Draft) are measured positive downwards. The deeper the transducer is beneath the

static waterline, the larger (more positive) the Static Draft Correction.

Static Draft can be corrected in one of two different methods in HYPACK®.

- **Enter the Static Draft adjustment into the Echosounder and set the vertical offset for the echosounder to 0.00 in the HARDWARE program.** Most surveyors use this method. The echosounder will then output a sounding that incorporates the static draft.
- **Set a Static Draft adjustment of 0.00 into the Echosounder and enter the static draft as the vertical offset into HYPACK®.**

BEWARE!

Do one or the other, *but not both*. Otherwise, you will be double-correcting for the Static Draft.

NOTE: If you are using Real Time Kinematics referencing the water line, you must include the static draft in your echosounder to get the correct tide information.

BATHY500.DLL

Version Number: 14.0.1.2

Device Name: Ocean Data Bathy 500

DEVICE SETUP

Depth: Logs soundings or magnetometer data from this device.

Use for matrix update: Color-codes a matrix based on the data received from this device.

Paper Annotation: Annotates each event on the sounder's paper roll. (See Driver Output.)

DRIVER SETUP

None

DEVICE OUTPUT STRINGS

2.6.3.3 PMC dt Format:

The structure for this industry standard output is shown below.

`_DT_xxx.x_FT<CRLF>` (English mode)

`_DT_xx.xx_MT<CRLF>` (Metric mode)

During normal operation the "space" in front of the "D" will be blank; An "E" in this space indicates an error such as lost bottom while an "F" indicates a Fix Mark. Xs indicate depth.

```
DT 50.43 MT
DT 50.42 MT
DT 50.42 MT
DT 50.41 MT
DT 50.40 MT
DT 50.41 MT
```

DRIVER OUTPUT STRINGS

DEVICE WINDOW:

Formats depth to 2 dec. and writes:

```
"Depth = Depth",  
("Depth = %.2lf",)
```

Formats EventNumber to 4 dec. and depth to 2 dec. and writes:

```
"EventNumber TypeFileName Time Depth"  
("%4.4lu %c%s %s %4.2lf)
```

SERIAL PORT:

On Event sends \006 then \001

Formats EventNumber to 4 dec. and depth to 2 dec. and writes:

```
"EventNumber TypeFileName Time Depth"  
("%4.4lu %c%s %s %4.2lf)
```

The driver then sends '\004'.

SPECIAL NOTES

Error Message: "Depth Error" triggered by depth = 0 or E as 1st char of string (string flags error).

BATHY1500.DLL

dlgoption

Version Number: 14.0.2.4

Device Name: Ocean Data Bathy 1500

DEVICE SETUP

Depth: Logs soundings or magnetometer data from this device.

Heave: Logs only heave from this device.

Use for matrix update: Color-codes a matrix based on the data received from this device.

Paper Annotation: Annotates each event on the sounder's paper roll. (See Driver Output.)

The annotation string is dependent on option in Driver Setup.

DRIVER SETUP

FIGURE 1. Bathy1500 Driver Setup

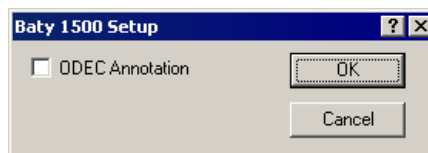

ODEC Annotation: sends \$GPANN string to both device window and serial port.

DEVICE OUTPUT STRINGS

A1.2.1 ODEC OUTPUT FORMATS

ODEC HEAVE FORMAT

Dual/single channel depth output plus heave values and additional information.

(Ex1. \$,D, ,01070,00000,2.3, ,01074,00000,2.2,F,4899

Ex2 \$,C, ,00402,00000,2.0, ,00508,00000,1.0,M,1500)

Baud Rate: 57600

\$E,C,s,dddd,+hhh,ooo,S,DDDD,+HHHH,OOO,U,yyyyy<CR><LF>

E	Normally a space, E indicates an event mark
C	C = Centimeter resolution (100 units or less), D = Decimeter Resolution, based on Channel 1 when in dual channel mode.
s	status flag channel 1, O = off, space = valid, E = not valid
dddd	depth value channel 1 without decimal point i.e with D (decimal) indicated above 193.5 meters would read 01935
+	+ = positive heave correction - = negative heave correction (heave at transmit + heave at receive)
hhh	heave correction in cm channel 1
ooo	draft offset transducer 1 (tenths of units)
S	status flag channel 2, 0 = off, space = valid, E = Not valid
DDDD	depth value channel 2 without decimal point
D	
+	+ = positive heave correction - = negative heave correction (heave correction +depth value = uncorrected depth at transducer).
HHHH	heave correction in cm channel 2
OOO	draft offset transducer 2 (tenths of units)
U	units, M = meters, F = Feet
yyyyy	sound speed in units without decimal (i.e. 1500 will be 1500 meters/second if units meters are selected)

ODEC DEPTH FORMAT - This format added to be compatible with Bathy 500. A single depth value is sent out for each transmit.

If the Event Key is pressed or triggered on unit, an event mark string is sent. Also indicated is bottom tracking information.

This output represents TRUE DEPTH; That is depth corrected for any offset (draft) which has been entered into the Bathy-1500 via the keypad.

Flag, ID, True Depth Units <CR><LF> (Fixed Sentence length 15 char)

(**Ex:** DT 19.4 MT)

Baud Rate: 9600
 sDT dddd.d uu<CR><LF>

s	Status flag—E =data error. F = Fix Mark.
DT	Sentence identifier
dddd.d	True Depth: FT or MT (leading zero is suppressed. Depth = 0 generates error.)
uu	Units (FT or MT)
<CR><LF>	EOL

DRIVER OUTPUT STRINGS

DEVICE WINDOW:

Writes original line.

If reading Bathy500 compatible string, and if flag in string is E or depth = 0, writes “depth error”.

If reading longer string format, and if depth=0, writes “Channel 1 Error” or “Channel 2 Error”.

If Echosounder is selected, writes:

"Depth1 = *Depth1*" or

"Depth2 = *Depth2*"

("Depth%i = %.2lf")

If Heave is selected, writes:

"Heave = *Heave*",

("Heave = %.2lf")

On Event:

- **If OPEC Annotation,**
 "\$GPANN, *EventNumber TypeLineName Time Depth1 Depth2*<CR><LF>
 ("GPANN,"%s\`\r\n")
- **If not OPEC Annotation,** formats depths to 2 dec. and writes:
 "*EventNumber TypeLineName Time Depth1 Depth2*"
 ("%4.4lu %c%s %s %5.2lf %5.2lf")

Where type is:

S for Start Line Event

E for End Line Event and

M for Manual Event

SERIAL PORT:

On Event:

- **If ODEC Annotation** sends:
*"\$GPANN, EventNumber TypeFileName Time Depth1
Depth2<CR><LF>*
- **If *not* ODEC Annotation**, sends:
\\006
\\001
EventNumber TypeFileName Time Depth1 Depth2
\\004

SPECIAL NOTES

ALARM TEXT:

“Depth Error”: Shorter form string is being read, and string flag is E or depth = 0.

“Channel 1” or **“Channel 2”**: Longer form string is read and string flag is not a space or depth = 0.

CEEDUCERPRO.DLL

Version Number: 9.0.1

Device Name: Ceeducer Pro

DEVICE SETUP

Position: Logs position data from this device.

From NMEA GGA strings.

Depth: Logs soundings or magnetometer data from this device.

From the Odom strings.

Heading: Logs heading data from this device.

From the NMEA VTG string

Speed: Displays speed data from this device.

Calculates speed data based on change in position over time.

Use for matrix update: Color-codes a matrix based on the data received from this device.

Paper Annotation: Annotates each event on the sounder's paper roll. (See Driver Output.)

DRIVER SETUP

None.

DEVICE OUTPUT STRINGS

- NMEA GGA string for position
- NMEA VTG string for heading
- Odom string for depth as follows:
 - **Single Frequency:** Tag Depth
et 575
et 575
et 574
 - **Dual Frequency:** Tag Depth1 Depth2
Et B 575 548
Et B 574 548
Et B 575 548

Et B 574 548

NOTE: Capitalized “ET” Tag indicates decimeter accuracy, while lowercase indicates centimeter accuracy. Values are converted to meters via a multiplier of 0.1 or 0.01 respectively.

5th Character	DeviceType
[Space]	Single Frequency
H	Dual bottom tracking-High Freq.
L	Dual bottom tracking-Low Freq
B	Dual bottom tracking-Dual Freq

DRIVER OUTPUT STRINGS

DEVICE WINDOW:

For each Odom String:

Formats depths to 2 dec and writes:

"Depth_h = Depth1 Depth_l = Depth0",

For each GGA string:

Formats and writes:

"X=X Y=Y

For each VTG String:

Formats and writes:

hdg=*Heading* speed=*Speed*"

SERIAL PORT:

Event:

“006”: Event mark sent to serial port.

Annotation string: Sends “\001” then:

- **If it’s a Start Line event:**
“EventNumber S filename time high freq depth distance made good\004”
- **If it’s an End Line event:**
”EventNumber E time high freq depth distance made good\004”
- **If it’s a Manual Event**
”EventNumber M filename time high freq depth distance made good\004”

- **If it's an Automatic Event:**
"EventNumber filename time high freq depth distance made good\004"

SPECIAL NOTES

Speed data calculated based on change of position over time.

CEESCOPE.DLL

Version Number: 17.1.1

Device Name: CEESCOPE

DEVICE SETUP

Depth: Logs soundings or magnetometer data from this device.

Tide: Logs tide data from this device.

Select this option only when the CEESCOPE is receiving tide gauge data via a telemetry link. For RTK-enabled CEESCOPE devices, use the gps.dll for RTK tides.

Heave: Logs heave, pitch and roll data from this device.

Record device specific messages: Logs additional data related to the device to the Raw file. Each record will be identified by a driver-specific, 3-character tag.

This driver records SMI records in the raw file. In addition, it stores echogram records in the bin file.

Paper Annotation: Annotates each event on the SURVEY Echogram window. (See Driver Output.)

Use for matrix update: Color-codes a matrix based on the data received from this device.

DRIVER SETUP

Recommended option uses a network connection. IP address and Port numbers are user configurable, the information below is based on factory default configuration:

- Default IP address of CEESCOPE is 192.168.2.1.
- Position data is sent via port 1234 and depth data is sent via port 1235.

Choose 1 channel or the other or both channels, depending on your model capability.

FIGURE 1. Driver Setup

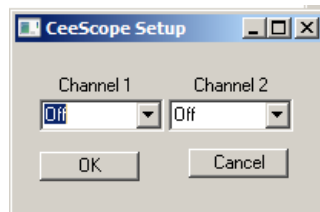

DEVICE OUTPUT STRINGS

Ethernet packet.

DRIVER OUTPUT STRINGS

DEVICE WINDOW:

Graphs the depths in a scrolling display and, in separate windows, it displays the echogram for each channel.

SPECIAL NOTES

The GPS is plugged into the CEESCOPE and the data passed over the network to HYPACK®. Use the GPS.dll for positioning and set the User Modified NMEA Messages option to POS (Ceescope) in the Advanced tab of the GPS.dll Driver Setup.

FIGURE 2. CEESCOPE.dll Setup for Depth and Heave with Default Connection Settings

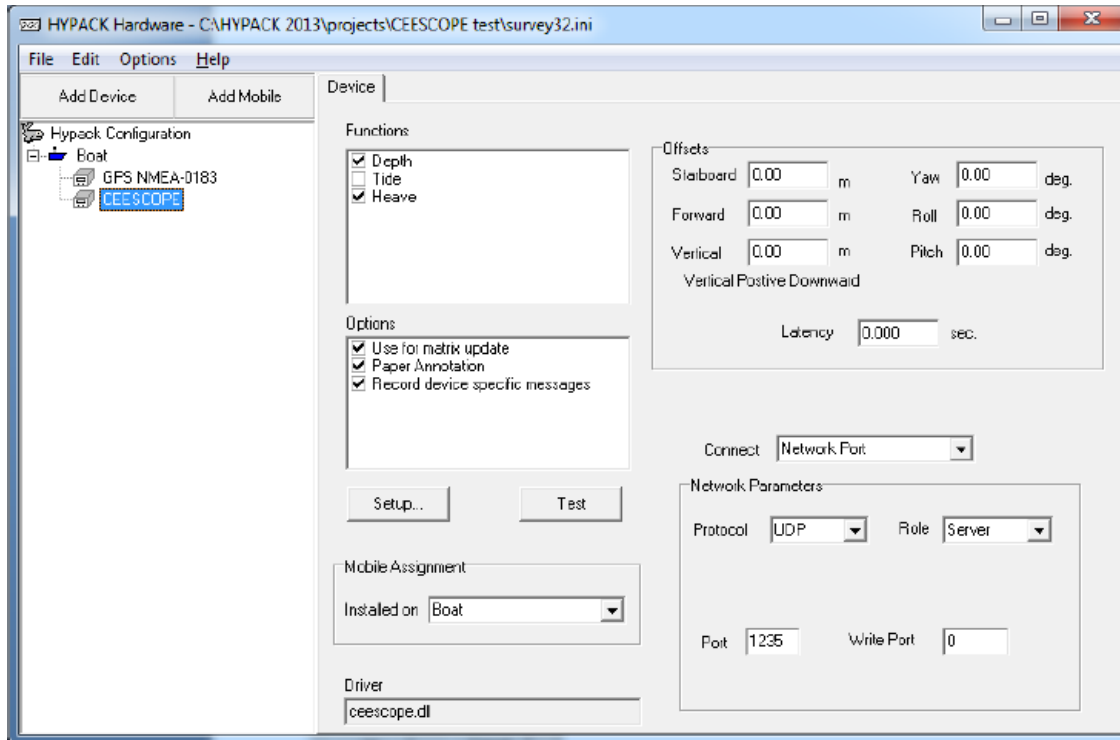
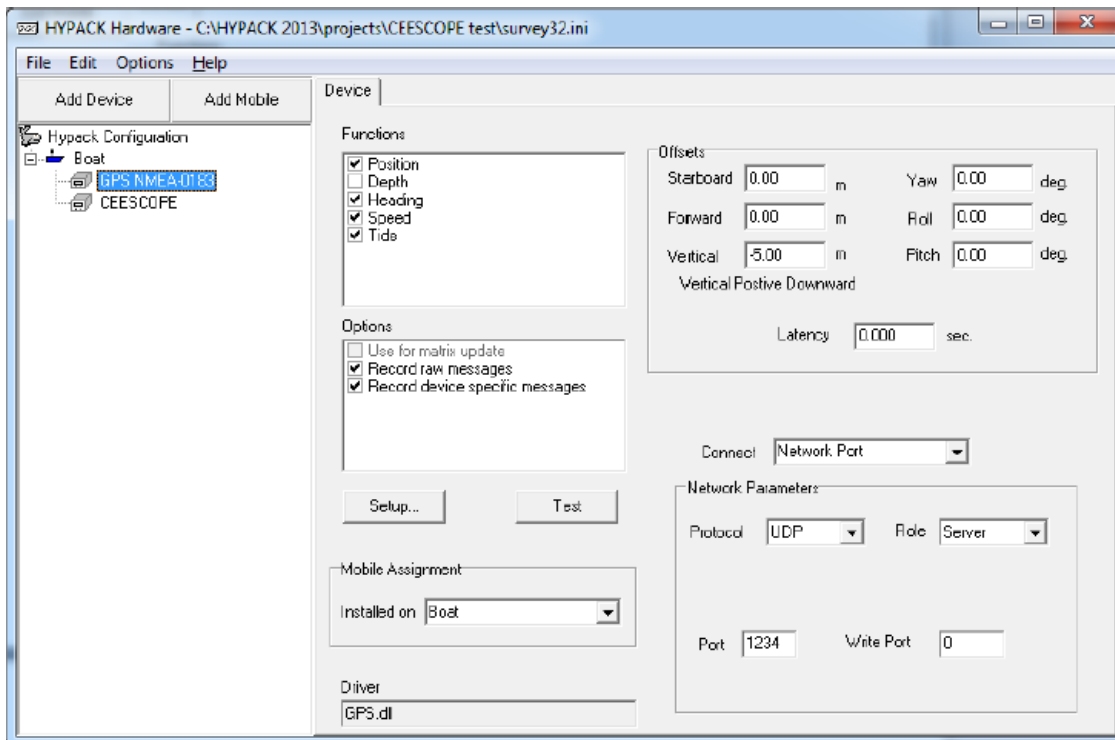

FIGURE 3. GPS.dll Setup for RTK Tides with Default Connection Settings

- Works in survey units.

DESO1517GLDD.DLL

Version Number: 14.0.1.3

Device Name: Atlas Deso 15/17GLDD

DEVICE SETUP

Depth: Logs soundings or magnetometer data from this device.

Heave: Logs only heave from this device.

DRIVER SETUP

FIGURE 1. Deso1517gldd Driver Setup



Enable Filter: If an error has been detected, depth is changed to 0.

Enable Alarm: Shows alarm button if driver detects an error in the string.

Swap Recorded Raw Depth Channels: switches depth1 and depth2

DEVICE OUTPUT STRINGS

*..900101790011359000008

Dep1 read from position 5-9

Dep2 read from position 12-16

Heave read from position 21. Inverted if 20th character is 1.

DRIVER OUTPUT STRINGS

DEVICE WINDOW:

Writes orig. line.

If there's no heave val., formats depths to 2 dec. and writes:
 "Ch1=Depth1 Ch2=Depth2",
 ("Ch1=%5.2f Ch2=%5.2f")

If there is heave, also formats heave to 2 dec. and writes:

"Ch1=*Depth1* Ch2=*Depth2* heave=*Heave*"
 ("Ch1=%5.2f Ch2=%5.2f heave=%5.2f")

NOTE: This is written *before* depths are swapped if that option has been selected.

If there's been an event, delays 5 msec and writes annotation string.

- **If no heave** format depths to 2 dec and all else to 1dec and writes:
 "WEventNumber Date Time LineName : DMG : XTE : Dep1 : Dep2"
- **If there is heave**, it writes the same with ": Heave" appended to end of string.

SERIAL PORT:

- **Initiate communication** with:
 PutLine("C0\n", 3);
 PutLine("S\n", 2);
- **On Event:** If start line event writes "G<CR>, M1<CR>"
 If not start line event: just writes "M1<CR>". It then delays 5 msec and sends annotation text (see Dev.Window.) out port.
 - **If it's been 15 msec since end line event with no further events**, sends F<CR>.
 - **If it's been more than 20msec, and nothing happens**, sends S<CR>.
- **End communication** with "S<CR> R<CR>".

SPECIAL NOTES

Alarms:

Deso 1	If there's an error in Ch1 and Ch1's <i>Enable Alarm</i> option is checked.
Deso 2	If there's an error in Ch2 and Ch2's <i>Enable Alarm</i> option is checked.
Deso1/2	If there are errors detected in both channels and at least one of the alarms are enabled.

NOTE: You can set the alarm to tell you there is an error detected but still keep the depths by not enabling the filter.

DESO17.DLL

Version Number: 9.0.2

Device Name: Atlas Deso 17

DEVICE SETUP

Depth: Logs soundings or magnetometer data from this device.

Use for matrix update: Color-codes a matrix based on the data received from this device.

Paper Annotation: Annotates each event on the sounder's paper roll. (See Driver Output.)

DRIVER SETUP

FIGURE 1. Deso 17 Driver Setup Dialog

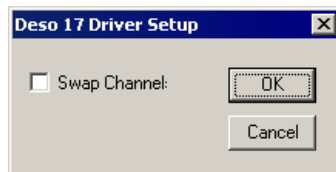

Swap Channels: The high frequency depth is normally configured as “Depth 1” and the low frequency depth is “Depth 2”. Check *Swap Channels* to reverse the depths.

DEVICE OUTPUT STRINGS

* . . 900089500000009000000

* . . 900089700000009000000

String Position	Content
5-10	Dep1
11	0
12-17	Dep2
18	0
19	Heave

DRIVER OUTPUT STRINGS

DEVICE WINDOW:

Writes original line.

Parses string, formats values and writes:

```
"Ch1=depth1 Ch2=depth2 heave=heave",  
("Ch1=%5.2f Ch2=%5.2f heave=%5.2f")
```

On event, if logging, writes "-----Event-----"

If loading geodesy fails, writes "Error Creating Geodesy".

SERIAL PORT:

On event

If it's a Start Log event, sends "G<LF>".

If it's an End Log event, sends "S<LF>".

Labels every 5th event and when string contains "READY".

- If there is a planned line, it sends:
"WEventNumber Date Time LineNumber<CR><LF>
(W%lu %s %s %i\r\n")
- If there's no planned line, it sends:
"WEventNumber Date Time<CR><LF>"
(W%lu %s %s\r\n", inf.event, szDate, szTime)
- In either case, it then sends:
M1<CR><LF>
(M1\r\n)

After reading each line, sends:

```
"CO<CR><LF>  
S<CR><LF>"
```

Ends communication by sending:

```
"S<LF> and R<LF>."
```

SPECIAL NOTES

Error Messages:

If loading geodesy fails, a message box displays the message "Error Creating Geodesy".

DESO25.DLL

Version Number: 9.0.0.7

Device Name: Atlas Deso25

DEVICE SETUP

Depth: Logs soundings or magnetometer data from this device.

Use for matrix update: Color-codes a matrix based on the data received from this device.

Paper Annotation: Annotates each event on the sounder's paper roll. (See Driver Output.)

DRIVER SETUP

FIGURE 1. Deso 25 Driver Setup

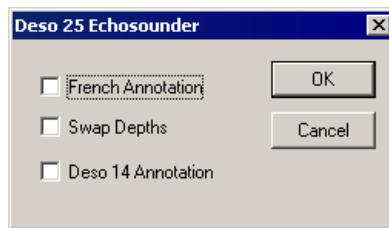

French Annotation: Event annotation strings.

- **When this option is selected:**
 - **Start of Line Events:** *TXEventNumber Time FileName*
<CR><LF> EM3 <CR> <LF>*<CR><LF>
 - **Other Events:** *TXEventNumber Time* <CR><LF> EM3
<CR> <LF> * <CR><LF>
- When this option is not selected, all events are the same:
TXEventNumber Time <CR><LF> EM3 <CR><LF> *
<CR><LF>

Swap Depths reverses high and low frequency.

Deso 14 Annotation: Uses the Deso 14 annotation format.

* *FixNumber FileName* <LF>

DEVICE OUTPUT STRINGS

Maximum string length of 255 chars..

If string contains DA, read starting right after that and save to depth1. If it contains DB, it does the same and saves to depth2.

End of Line is *.

DRIVER OUTPUT STRINGS

DEVICE WINDOW:

Writes original data string.

If either depth equals other than 0:

```
"dep=depth1 dep2=depth2"
```

```
("dep=%5.2f dep2=%5.2f")
```

At each event, writes the string:

```
"TX EventNumber Time <CR><LF>  
EM3<CR><LF>"
```

```
("TX%lu %s\r\nEM3\r\n*\r\n")
```

If the Deso 14 annotation option is selected, it writes:

```
"* Fix Number File Name LF"
```

SERIAL PORT:

At each event, sends the string to serial port:

```
"TX EventNumber Time <CR><LF>  
EM3<CR><LF>" .
```

```
("TX%lu %s\r\nEM3\r\n*\r\n")
```

DATA DISPLAY:

Includes both Depth1 and Depth2.

KNOWN DEVICES:

- DESO-25
- DESO-22.

SPECIAL NOTES:

Most of the time, Surveyors using Navisound215 set up the Navisound to output the Deso format message. They then use the DESO25.DLL device driver.

DTRACE.DLL

Version Number: 9.0.1.1

Device Name: Odom Digitrace

DEVICE SETUP

Depth: Logs soundings or magnetometer data from this device.

Use for matrix update: Color-codes a matrix based on the data received from this device.

Paper Annotation: Annotates each event on the sounder's paper roll. (See Driver Output.)

DRIVER SETUP

FIGURE 1. DTrace Driver Setup

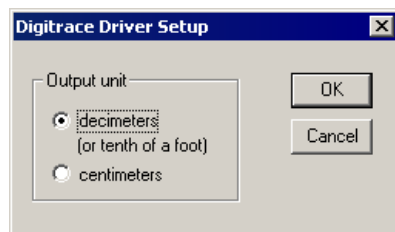

Digitrace outputs depths without a decimal.

Decimeters: the output depth is divided by 10 and stores it to your Raw data file.

Centimeters: the output depth is divided by 100 and stores it to your Raw data file.

DEVICE OUTPUT STRINGS

Tag, Depth

Ex.:

xDTxxx120

DRIVER OUTPUT STRINGS:

DEVICE WINDOW:

Sends the original string to the Device Window. If the 4th character is "E" it writes "Error" to the Device Window.

Calculates the depth, formats it (%6.2f) and writes it to the Device Window as:

"dep=*Depth*",

Event Mark:

Clears RTS, pauses 300msec. and sends an RTS pulse followed by an "F" character. There is no annotation text.

SPECIAL NOTES

"**Error**" in the device window indicates 4th character in the data string is "E" and that it is not a depth reading.

Saves last reading only to Raw.

EA300.DLL

Version Number: 9.0.1.2

Device Name: Simrad EA300 Echosounder

DEVICE SETUP

Depth: Logs soundings or magnetometer data from this device.

Use for matrix update: Color-codes a matrix based on the data received from this device.

Paper Annotation: Annotates each event on the sounder's paper roll. (See Driver Output.)

DRIVER SETUP

None

DEVICE OUTPUT STRINGS

String begins with a space followed by the depth value.

DRIVER OUTPUT STRINGS

DEVICE WINDOW:

Writes the original data string then formats the depth and writes:

```
"dep=depth"  
("dep=%5.2f")
```

SERIAL PORT:

Only output if there is a planned survey line.

```
"<enquiry>*EventNumber<CR><LF>  
\001 Time Line LineNumber depth=Depth<CR><LF>"  
("\005*%4.4lu\r\n"  
\001 %s Line %i depth=%5.2f\r\n")
```

SPECIAL NOTES

If there's an error in reading the line (status <0), sends Error Message "Comm err=x" where x is the status.

EA500.DLL

The EA400 is a multiple channel echosounder that can be connected with up to four separate transducers. It can output depth telegrams through a serial link or a network connection. It also supports standard NMEA-0183 sentences (DBT, DBS, DPT) so it can be integrated in HYPACK® using the standard NMEA driver, but in this case, it outputs only one channel (user-selectable) and there is no annotation support.

Version Number: 11.1.3.2

Device Name: Kongsberg EA500 or EA400 Echosounder

DEVICE SETUP

Depth: Logs soundings or magnetometer data from this device.

Use for matrix update: Color-codes a matrix based on the data received from this device.

Paper Annotation: Annotates each event on the sounder's paper roll. (See Driver Output.)

DRIVER SETUP

FIGURE 1. EA500 Driver Setup

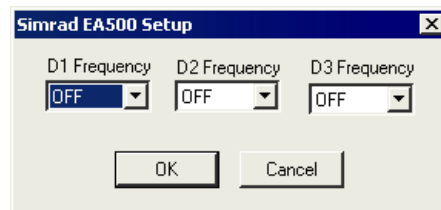

D1, D2, D3 Frequencies: Define the channel from which each frequency (high and low) is read.

High Frequency (200Hz) and **Low Frequency** (38Hz) defines the channels to be recorded. These frequencies will also be selected in the EA500 program in the Serial Interface dialog under Kongsberg.

If the echosounder is single frequency, two of the selections would be "Off" and SURVEY will save an EC1 record in the raw data. If it's dual frequency, one selection is "Off" and an EC2 record will be created.

CONNECTION

SERIAL CONNECTIONS:

In the Kongsberg interface, select which frequency you will be using. In the HYPACK® HARDWARE configuration, you must set the port used to read each frequency selected here.

Datagram Input: Check the check boxes corresponding to the desired channels. The 'Annotation' check box in the 'Datagram Input' is an interesting one: despite the manual's claim that the echosounder will accept annotation input on the same serial port, it doesn't do it. *The annotation string has to come across the 'Navigation Input' serial port or across the network. So...*

- **Use a split serial cable between HYPACK® computer and the Kongsberg computer.** The serial output of the HYPACK® computer is connected to the serial input of a different port on the Kongsberg computer (configured as navigation input).
- **In the 'Navigation Interface' dialog box press the 'Depth Output...' button.**

This provides Depth Output on the Navigation Input serial port on which annotation can be sent by selecting *Depth Output* and the *Kongsberg Telegram* format.

FIGURE 2. Serial Interface Dialog from the Kongsberg EA500 Program

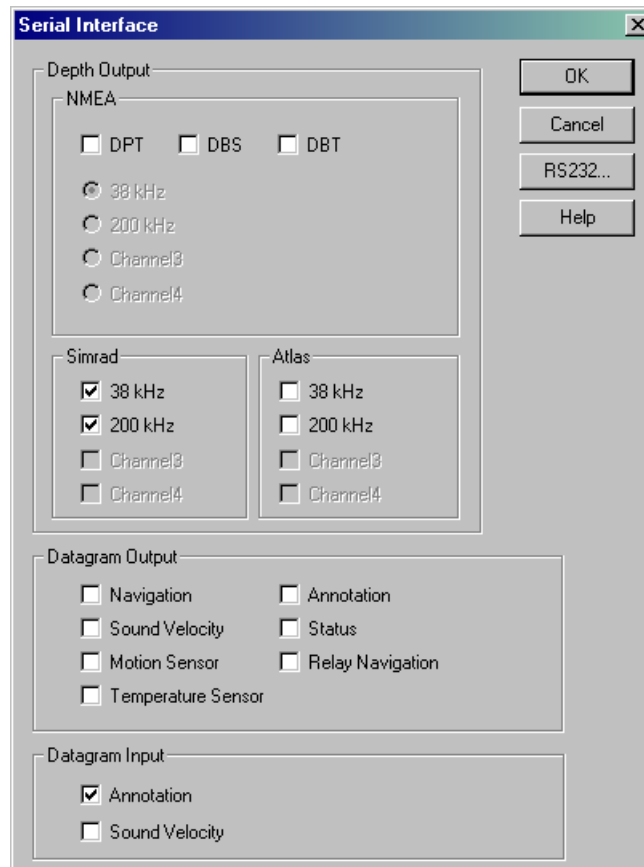
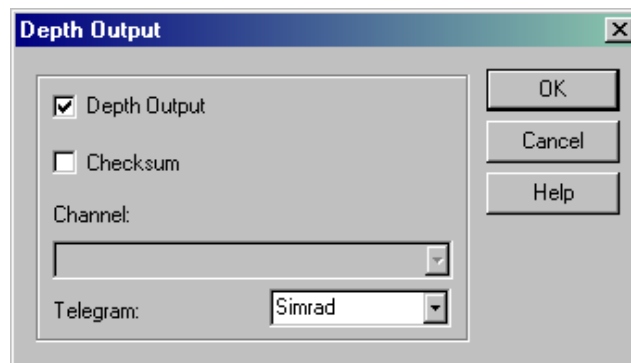

FIGURE 3. Depth Output Dialog from the Kongsberg EA500 Program



Because the depth information for each channel is sent in a separate message the time tag recorded in HYPACK® raw files will be the time tag of the last received message.

NETWORK CONNECTIONS:

HYPACK® can be configured as a client or as a server. In either case, the selected protocol is UDP and the port numbers must match the ones selected in the EA400 program.

The EA400 transmits depth information using the UDP protocol. In the Network Interface dialog, select the IP address of the HYPACK® computer and port numbers. Alternatively, you can select the broadcast address 255. 255. 255. 255.

The EA400 program can be run on the same machine as HYPACK®. In that case, set the host IP address to 127.0.0.1 (local host address).

FIGURE 4. EA400 Interface

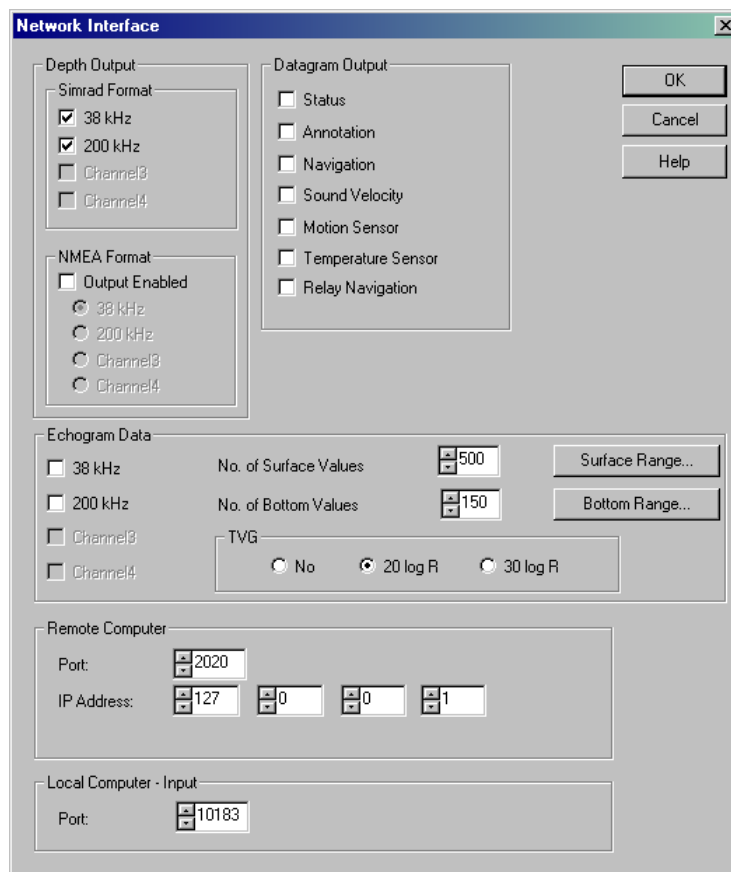

DEVICE OUTPUT STRINGS

Native Kongsberg telegram format:

D#, HHMMSShh, Depth, Reflectivity, TransducerNumber, AthwartshipsAngle where :

D# is the header with # indicating the channel number.

HHMMSShh is the time at the ping.

Sample output:

```
D1,13053440, 0.00,-28, 1, 0
D2,13053440, 0.00, 5, 1, 0
D1,13053483, 37.75,-28, 1, 0
D2,13053483, 10.74, 5, 1, 0
```

DRIVER OUTPUT STRINGS

DEVICE WINDOW:

Writes original string.

If the string is from a channel number selected in the driver setup, extracts the depth and writes:

Channel Channel# = Depth

- **Single Frequency:**
Formats to 2 decimal and writes:
"High Frequency = Depth1" or
"Low Frequency = Depth2"
- **Dual Frequency:**
Waits for both frequencies, formats them to 2 decimals and writes:
"High Frequency = Depth1"
"Low Frequency = Depth2"

SPECIAL NOTES

The annotation string has to come across the Navigation Input serial port or across the network (in spite of what their documentation says).

Error Message: "Unknown Telegram" if data begins with something other than chars. described under T in Header Type.

Alternate driver: Kongsberg Network Driver.

ECHOLOGGER.DLL

Version Number: 17.2.1

Device Name: Echologger

DEVICE SETUP

Depth: Logs soundings or magnetometer data from this device.

Record device specific messages: Logs additional data related to the device to the Raw file. Each record will be identified by a driver-specific, 3-character tag.

Use for matrix update: Color-codes a matrix based on the data received from this device.

DRIVER SETUP

None

CONNECTION SETTINGS

Serial: 115200,8,1,none, none

DEVICE OUTPUT STRINGS

ECHO TXT 12-BIT

Each record from the device includes numerous labeled “header strings” followed by “nSamples” data values.

Sample:

```
#DeviceID 221 Type USB / RS-232, 422, 485
#TimeLocal 20170831 13:00:07.58
#TimeUTC 20170831 18:00:07.58
$GPZDA,180007.58,31,08,2017,-5,-300*6D
#TimeWork 621349.562
#Ping 52539
#Altitude,m 0.1264
#Temperature,°C 23.80
#NSamples 6748
```

```

#Resolution,mm 14.818
#SoundSpeed,mps 1500.00
#-----Parameters-----
#Tx_Frequency,Hz 450000
#Range,m 100.0
#Interval,sec 0.50
#Threshold,% 10
#Offset,m 0.000
#Deadzone,m 0.150
#PulseLength,uks 50
#TVG_Gain 0.000
#TVG_Slope 1.000
#TVG_Mode 1
#OutputMode 2
#Pitch,deg -43.225
#Roll,deg 31.475
#VertRotationPos,deg 37.300
$YXXDR,A,-43.2,D,PTCH,A,31.5,D,ROLL*72
#-----DEBUG Info-----
#DEBUG_EchoMaxAmplitude,% 61
#DEBUG_EchoMaxAmplitudeLev,mV 1995
#DEBUG_EchoMaxAmplitudeN 619
#DEBUG_Sampling_Frequency,Hz 50615
#DEBUG_OneSampleDistance,mm 14.818
#DEBUG_ZeroLevel 0
#DEBUG_ADCMaxAmplitude,mV 3300
#DEBUG_RealPulseLength,uks 61
#DEBUG_NSamples 6748
##DataStart
13
6
16
78
327
646
...
##DataEnd

```

BINARY “ECHO BIN 12-BIT” DESCRIPTION

```

struct d24_header
{
char magic [8]; // "ECHOLOGG"
char packetid [2]; // "EC" or "GP"
UINT32 length; // includes header (42 - 26760)
};
struct d24_echosounder_datagram
{
UINT32 time; // seconds past 1/1/1970
UINT32 timems; // milliseconds past current second

```

```
UINT32 pingnum; // ping number
float altitude; // measured altitude (0 - 200) meters
float temperature; // water temp (-10 - +50) degrees Celsius
float pitch; // (-90 - +90) degrees
float roll; // (-90 - +90) degrees
INT32 dataformat; // 0 = 12 bit, 1 = 8 bit companded
INT32 samplesnum; // (144 - 30000)
//UINT16 * samples; // 12 bit or 8 bit
};
```

DRIVER OUTPUT

DEVICE WINDOW:

When settings are changed and the Apply button is pressed, the device is sent the commands to change the changed settings and all settings are reloaded to ensure proper changes were made. Changes can only be made while not logging.

There are certain options that EU400 does not have. These are disabled, when an EU400 echologger is attached.

Changes may not be recognized by the device sometimes and will change back to their original settings after Apply is hit. It may just take a few tries for the device to accept the input you give it.

EU400 is always 450kHz. D24 allows switching between low and high frequency.

The depth is displayed on the status bar at the bottom of the device window.

ECHOGRAM WINDOW:

Digital echogram display.

SPECIAL NOTES

KNOWN SUPPORTED DEVICES

EU400 & EU D24

The other 400 and D24 devices appear to be covered but haven't been tested.

ECHOTOT.DLL

Version Number: 12.0.1.3

Device Name: Universal Echosounder Driver

DEVICE SETUP

Depth: Logs soundings or magnetometer data from this device.

Use for matrix update: Color-codes a matrix based on the data received from this device.

Paper Annotation: Annotates each event on the sounder's paper roll. (See Driver Output.)

DRIVER SETUP

FIGURE 1. Driver Setup

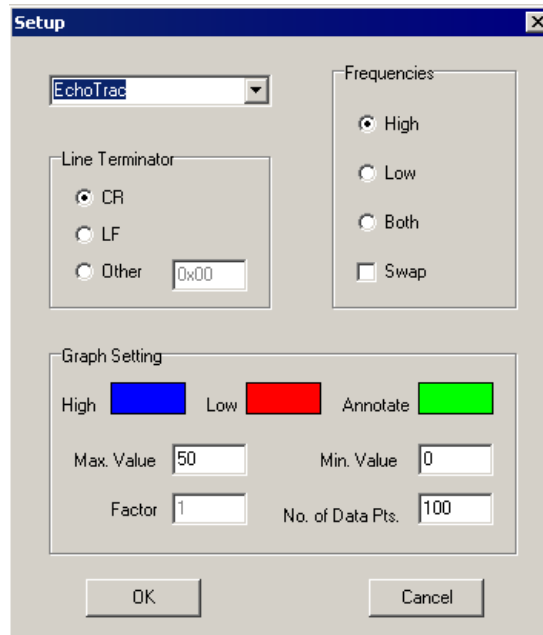

Echosounder Type: Select your sounder from the drop-down list.

Line Terminator: Select CR (carriage return), LF (line feed) or define an alternate terminator using its hex code.

Frequencies: Elect to read high (Dep1) or low frequency (Dep2), or both.

Swap: Reverses Dep1 and Dep2

Graph Settings configure the scrolling graph in the device window.

- **Colors:** Customize the colors for each frequency and for the annotation by clicking on the corresponding color square and choosing your color from a color select dialog.
- **Max Value** and **Minimum Value** configure the vertical range of the graph.
- **Factor:** Multiply the depth values by this factor.
- **Number of Data Points:** Sets the number of soundings (essentially the horizontal range) in the Device Window display.

DEVICE OUTPUT STRINGS

<p>Echotrac and EchotrackGLDD</p>	<p><code>_ET_BC_ddd_ddd<CR></code> The driver accepts the following input string (spaces are represented by '_'): <code>_ET_BC_ddd_ddd<CR></code> where: ET: Tag. If lower-case, the depth is in centimeters. Error flag ('E' or ' ') B : Channels Tracked (B = Dual Freq., H = High Freq. L = Low Freq.) C: Heave compensator flag (C or ' ') ddd_ddd : Depth1_Depth2 <CR>: Carriage Return EOL Sample Output: Single frequency: <code>ET H 176</code> Dual frequency: <code>ET B 564 604</code></p>
<p>Inn455</p>	<ul style="list-style-type: none"> • If you are using it with a GPS, output IT-Multiple. • If you are using it without a GPS, output IT.

Echomod4	<p>Data String: 80 char maximum. If 2nd char is E, it produces an error message. Depth is read starting at 5th char. and divided by 10. 3rd char indicates High (H) or Low (L) frequency.</p> <p>Other Output: Sends Ctrl+ after receiving a start log event annotation.</p>
Inn448	<p><code>_DDDDDB<CR></code> where: D: = (Depth)10 B: = Bad Data flag (1=bad data)</p> <p>Sample String: <code>_00310</code></p>
Inn449	<p><code>DDDDDB<CR><LF></code> where: D: = Depth B: = Bad Data flag (1=bad data)</p>
Inn440s	<p>Depth read from 2nd character and divided by 10. 6th character is the bad data flag. 1=bad data.</p>

DRIVER OUTPUT STRINGS

DEVICE WINDOW:

Scrolling graph of depths over time.

<p>Echotrac</p>	<p>Writes original line.</p> <p>If the 4th char. is E, writes "Error".</p> <ul style="list-style-type: none"> • Single Frequency: Formats depth to 1 dec. and writes: "dep=<i>depth</i>", (<i>"dep=%5.1f"</i>) • Dual bottom tracking-High Freq. Formats depth to 1 dec and writes: "dep high=<i>depth</i>" (<i>dep high=%5.1f</i>) • Dual bottom tracking-Low Freq Formats depth to 1 dec and writes: "dep low=<i>depth</i>" (<i>dep low=%5.1f</i>) • Dual bottom tracking-Dual Freq Formats depths to 1 dec and writes: "dep low=<i>depth0</i> high= <i>depth1</i>", "dep low=%5.1f high=%5.1f",
<p>EchotrackGLDD</p>	<p>Writes the original string.</p> <p>Parses string, formats values and writes: "dep ch1=<i>depth1</i> ch2=<i>depth2</i> heave=<i>heave</i>", (<i>"Ch1=%5.2f Ch2=%5.2f heave=%5.2f"</i>)</p>
<p>Inn455</p>	<ul style="list-style-type: none"> • If you are using it <i>with</i> the GPS, Inn455 should output IT-Multiple. • If you are using it <i>without</i> the GPS, Inn455 should output IT.

Echomod4	<ul style="list-style-type: none"> • Writes original string to Device Window. • If 2nd char. is “E”, “Error” is displayed. • If 3rd char is “H”, writes: <code>"hi=depth"</code> <code>"hi=%5.1f"</code> • If 3rd char is “L”, writes: <code>"lo=depth"</code> <code>"lo=%5.1f"</code> • When there’s a “start log” event <ul style="list-style-type: none"> • it writes “Sent Start Event Mark”. • If you are using planned lines, it formats and writes: <code>"EventNumber LineNumber Time MobileDepth</code> <code>as</code> <code>"%4.4lu %3.3i %s %4.1lf\r"</code> where Time is formatted HH:MM:SS<null> • For event types other than Start Log: <ul style="list-style-type: none"> • Writes “Sent Event Mark” then • EventNumber<CR>
Inn448	<p>“Depth=<i>Depth</i>” followed by “Bad” (if 6th character of the string is “1”) or “OK”</p> <p>Depth is formatted to 2 decimals.</p> <pre>("depth=%5.2lf %s", depth, (bad_data)?"Bad":"Ok")</pre> <p>On events:</p> <ul style="list-style-type: none"> • No survey line: writes <code>"\002\001NO LINE<CR></code> <code>\002\002<CR></code> <code>\002\003<i>EventType#</i><CR></code> <code>\002\005<i>EventTypeChar</i><CR></code> <code>\003"</code> • With survey line, writes: <code>002\001<i>LineName</i><CR></code> <code>002\002<i>Depth</i><CR></code> <code>002\003<i>Event#</i><CR></code> <code>002\005<i>Type</i><CR></code> <code>003</code> <p>where:</p> <ul style="list-style-type: none"> • Start Event is Event Type# 1 and Symbol "S". • End Event is Event Type# 2 and Symbol "E". • Manual Event is Event Type# 3 and Symbol "M".

<p>Inn449</p>	<p>Formats depths to 2 decimals and writes: "Depth=Depth" followed by "Bad" or "OK" (based on the 6th character of the string). ("depth=%5.2lf %s")</p>
<p>Inn440s</p>	<p>Formats depth to 2 dec. and writes: "depth=Depth OK/Bad" ("depth=%5.2f %s") where OK/Bad is either "Ok" or "Bad" depending on the status of the bad_data flag.</p>

SERIAL PORT:

<p>Echotrac</p>	<p>"006": Event mark sent to serial port. Annotation string: If "Don't Annotate" option is <i>not</i> selected, it sends "\001" then:</p> <ul style="list-style-type: none"> • If it's a Start Line event: "EventNumber S filename time high freq depth distance made good\004" • If it's an End Line event: "EventNumber E time high freq depth distance made good\004" • If it's a Manual Event "EventNumber M filename time high freq depth distance made good\004" • If it's an AutomaticEvent: "EventNumber filename time high freq depth distance made good\004"
<p>EchotrackGLDD</p>	<p>To generate the event mark, the driver sends the hex character '06' (control-F) followed by the annotation string: <pre>\x01 EventNumber Date Time LineName DMG XTE Depth1 Depth2 \x04 (\x01%4.4E %D %h %L %.1M %.1t %.2Z %.2z \x04)</pre></p>
<p>Inn455</p>	<ul style="list-style-type: none"> • If Paper Annotation option is selected: <ul style="list-style-type: none"> • If using planned lines writes: "\$E Line: LineName Depth: Depth Event: -Event# \015\012" (" \$E Line: %s Depth: %.2lf Event: %-5lu \015\012") • If no planned lines, writes: "\$E Depth: Depth Event: -Event# \015\012" "\$E Depth: %.2lf Event: %-5lu \015\012",

Echomod4	<ul style="list-style-type: none"> • On a Start Log Event: <ul style="list-style-type: none"> • "\006\001" draws a vertical line to the log. • If you are using planned lines, it sends: "EventNumber LineNumber Time MobileDepth<CR> \004" ("%4.4lu %3.3i %s %4.1lf\r") • On event types other than Start Log: <ul style="list-style-type: none"> • "\006\010" makes a horizontal annotation (<i>CTRL-F and CTRL-H</i>) • EventNumber<CR> (%lu\r).
Inn448	<p>On Event: \006 out the serial port to mark the event.</p> <p>If Annotation string option is chosen: And if Start Line Event, writes Header:</p> <ul style="list-style-type: none"> • No survey Line writes: "\002\014LINE AZ:???? DATE: <i>mm-dd-yyyy</i><CR> \002\015JOB: <i>JobName</i><CR> \002\016PROJECT: <i>ProjectName</i><CR> \003" • With survey line "\002\014LINE AZ:<i>LineAzimuth</i> DATE: <i>mm-dd-yyyy</i><CR> \002\015JOB: <i>JobName</i><CR> \002\016PROJECT: <i>ProjectName</i><CR> \003" <p>Where Job Name and Project Name are read from Survey32.ini (after the user has defined them in SURVEY through OPTIONS-PROJECT INFORMATION).</p> <p>For all event types, also includes same lines written to the Device Window.</p>

Inn449	<p>Sends \006 out the serial port to mark the event.</p> <p>If Annotation string option is chosen: And if Start Logging with Planned Line writes: "\002\003EventNumber<CR> \002\001LINE N#LineNumber<CR> \002\005TypeChar<CR> \003" All other events writes: "\002\003EventNumber<CR> \002\005TypeChar<CR> \003" where: S = Start Logging E = End Logging M = Manual Event</p> <hr/> <p>NOTE: Annotation is an additional option. If you did not purchase this option, HYPACK® MAX cannot annotate your echosounder. Before calling Technical Support about your annotation (or lack thereof), please check to make sure that option was actually purchased for your echosounder</p> <hr/>
Inn440s	On event, sends "\006"-signals annotation.

KNOWN DEVICES

- Echomod4
- Echotrac
- EchotrackGLDD
- Innerspace 440s
- Innerspace 448
- Innerspace 449
- Innerspace 455
- Innerspace 456

SPECIAL NOTES

ECHOTRAC.DLL

Device Name: Odom Hydrotrac/Echotrac

Version: 9.0.2.4

DEVICE SETUP

Depth: Logs soundings or magnetometer data from this device.

Use for matrix update: Color-codes a matrix based on the data received from this device.

Paper Annotation: Annotates each event on the sounder's paper roll. (See Driver Output.)

DRIVER SETUP

FIGURE 1. Driver Setup Dialog

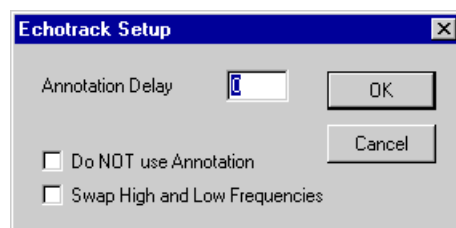

Annotation Delay (msec) is the amount of time the Survey program will allow the echosounder to process the annotation data before attempting to place it back in sounding mode. If the Annotation Delay is too small, your sounder will occasionally lock up in annotation mode and must be reset. If it is too large, you will have larger gaps in your sounding data after event marks. The default value is 25 msec.

In dual frequency operations, both high and low frequency data are displayed continuously.

Do Not Use Annotation: Omits *text* annotation. Line will still be drawn if you select "Paper Annotation" in the device setup.

Swap High and Low Frequencies: The high frequency depth is normally configured as "Depth 1" and the low frequency depth is "Depth 2". Check this option to reverse the depths

DEVICE OUTPUT STRINGS

Single Frequency: Tag Depth

et 575
 et 575
 et 574

Dual Frequency: Tag Depth1 Depth2

et B 575 548
 Et B 574 548
 Et B 575 548
 Et B 574 548

NOTE: Capitalized “ET” Tag indicates decimeter accuracy, while lowercase indicates centimeter accuracy. Values are converted to meters via a multiplier of 0.1 or 0.01 respectively.

5th Character	Device Type
[Space]	Single Frequency
H	Dual bottom tracking-High Freq.
L	Dual bottom tracking-Low Freq
B	Dual bottom tracking-Dual Freq

DRIVER OUTPUT STRINGS

DEVICE WINDOW

Writes original line.

If the 4th char. is E, writes “Error”.

Device Type	Output
Single Frequency	Formats depth to 1 dec. and writes: "dep= <i>depth</i> ", ("dep=%5.1f")
Dual bottom tracking-High Freq.	Formats depth to 1 dec and writes: "dep high= <i>depth</i> " (dep high=%5.1f)

Device Type	Output
Dual bottom tracking- Low Freq	Formats depth to 1 dec and writes: "dep low= <i>depth</i> " (dep low=%5.1f)
Dual bottom tracking- Dual Freq	Formats depths to 1 dec and writes: "dep low= <i>depth0</i> high= <i>depth1</i> ", "dep low=%5.1f high=%5.1f",

SERIAL PORT:

"006": Event mark sent to serial port.

Annotation string: If "Don't Annotate" option is *not* selected, it sends "\001" then:

- **If it's a Start Line event:**
"EventNumber *S* filename time high freq depth distance made good\004"
- **If it's an End Line event:**
"EventNumber *E* time high freq depth distance made good\004"
- **If it's a Manual Event**
"EventNumber *M* filename time high freq depth distance made good\004"
- **If it's an Automatic Event:**
"EventNumber filename time high freq depth distance made good\004"

SPECIAL NOTES

ECHOTRACGLDD.DLL

Version Number: 10.0.2.5

Device Name: Odom Echotrac Mark I, Mark II and MARK III driver for Great Lakes and Dredges

DEVICE SETUP

Depth: Logs soundings or magnetometer data from this device.

Use for matrix update: Color-codes a matrix based on the data received from this device.

Paper Annotation: Annotates each event on the sounder's paper roll. (See Driver Output.)

DRIVER SETUP

FIGURE 1. Setup Dialog

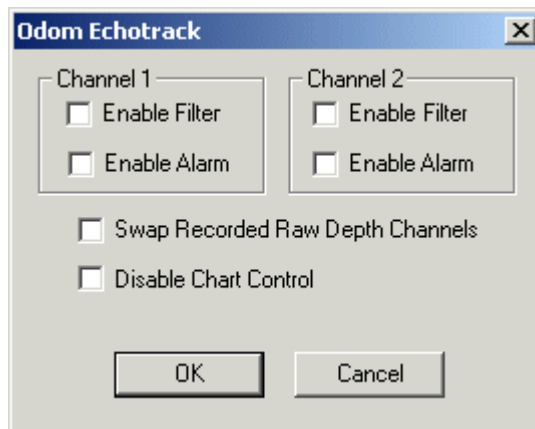

For each depth channel:

- **Enable Alarm:** If unchecked the driver does not report error conditions on that channel.

Swap Recorded Raw Depth Channels: Swaps the two depth channels. The first channel is reported as low frequency depth and the second is reported as high frequency.

Disable Chart Control: If unchecked the driver turns on the paper chart at start of line and turn it off at end of line.

DEVICE OUTPUT STRINGS

`_etEBC_ddd_ddd<CR>`

where:

`_` : space

et: tag. If it's lower-case, the depth is in centimeters. Capital letters indicate decimeters. Driver converts to meters via a multiplier.

E: Error tag. 'E' - error, otherwise ''

B: Channels tracked. 'B'- dual frequency, 'H' - High Freq., 'L'-Low Freq.

C: Heave compensator flag. 'C' or ''

ddd: Depths, high frequency first, then low frequency

SAMPLE SINGLE FREQUENCY:

```
ET H 176
ET H 175
ET H 175
ET H 176
ET H 177
```

DUAL FREQUENCY

```
ET B 565 604
ET B 564 604
ET B 564 604
ET B 565 604
ET B 565 605
```

DRIVER OUTPUT STRINGS

DEVICE WINDOW:

Writes the original string.

Parses string, formats values and writes:

```
"dep ch1=depth1 ch2=depth2 heave=heave",
("Ch1=%5.2f Ch2=%5.2f heave=%5.2f")
```

SERIAL PORT:

To generate the event mark, the driver sends the hex character '06' (control-F) followed by the annotation string:

```
\x01 EventNumber Date Time LineName | DMG | XTE | Depth1 |
Depth2 \x04
(\x01%4.4E %D %h %L | %.1M | %.1t | %.2Z | %.2z \x04)
```

SPECIAL NOTES

BUGS:

- Filter Options are not used
- Chart control is “flaky”. Chart is turned on even if the control is checked, but then it’s never turned off.
- Uses “annotation delay” but the actual value is not set.

ELAC4300.DLL

Version Number: 6.2.1.1

Device Name: Elac MKII Hydrostar 4300

DEVICE SETUP

Depth: Logs soundings or magnetometer data from this device.

Use for matrix update: Color-codes a matrix based on the data received from this device.

Paper Annotation: Annotates each event on the sounder's paper roll. (See Driver Output.)

NOTE: If this option is not selected, no annotation will be sent regardless of annotation selection in the driver setup.

DRIVER SETUP

FIGURE 1. Elac4300 Driver Setup

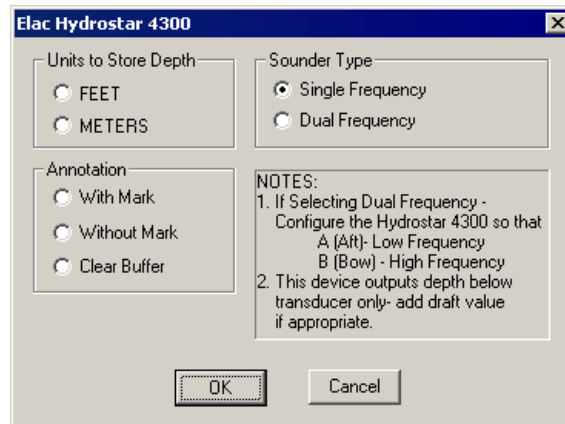

Units to Store Depth: Choose either feet or meters.

Sounder Type: Select according to your system type.

Annotation: determines what is sent to the device and device window at each event for the annotation. (See Driver Output Strings.)

DEVICE OUTPUT STRINGS

Original output string has 8 comma delimited fields
(EX \$PELACSDS,A,0013.10,00.0,-00.0,S,2,*13) where:

Field 1	sentence identifier, mnemonic code (\$PELACSDS)
Field 2	transducer location (s=Starboard, p=Port, b=Bow, A=Aft, o=N/A)
Field 3	depth in meters
Field 4	draft (distance transducer below surface)
Field 5	trim (distance transducer below keel)
Field 6	depth below (κ=Keel, s=Surface, τ=Transducer)
Field 7	depth quality
Field 8	checksum

DRIVER OUTPUT STRINGS

DEVICE WINDOW:

Writes original line.

If the device is Single Frequency:

Reads depth to 2 decimals and writes it as

```
"Depth=depth units=units"  
("Depth=%5.2f units=%s")
```

If the device is Dual Frequency the same sentence is preceded by "(Low)" or "(High)" depending on whether 2nd char in the string is "A" or "B" respectively.

On event, sends one of the following according to Driver Setup selection:

- If **"With Mark"** option is selected, writes:
"\$PELATM, EventNumber_Time_LineName_Mobile.X_Mobile.Y"
where Event Number is formatted as: "%05d_" and the rest as:
("%s_%8s_%11.2lf_%11.2lf*")
- If **"Without Mark"** is selected, writes:
"\$PELAT, Time_LineName_Mobile.X_Mobile.Y" @S
("%s_%8s_%11.2lf_%11.2lf*")
- If **"Clear"** is selected, writes:
"\$PELATC, "

EVENT MARK:

Sends same line as seen in the Device Window on event, appended with CR/LF, out Serial Port.

SPECIAL NOTES

Error "**No sentence start – ignored**" is written to the Device Window if the data string does not start with "\$".

Error "**Missing subfield-ignored**" is written to the Device Window if the driver does not count 8 fields in the original string.

Error "**Unsupported Sentence Type - ignored**" is written to the Device Window if the sentence doesn't begin with \$PELACSDS.

Error "**Depth Not From Surface!!! – Ignored**" is written to the Device Window if 6th field is not "s" indicating Surface.

E-SEA.DLL

Version Number: 9.0.0.4

Device Name: Marimatech E-sea Echosounder

DEVICE SETUP

Depth: Logs soundings or magnetometer data from this device.

Heave: Logs heave, pitch and roll data from this device.

Use for matrix update: Color-codes a matrix based on the data received from this device.

Paper Annotation: Annotates each event on the sounder's paper roll. (See Driver Output.)

DRIVER SETUP

FIGURE 1. E-Sea Driver Setup

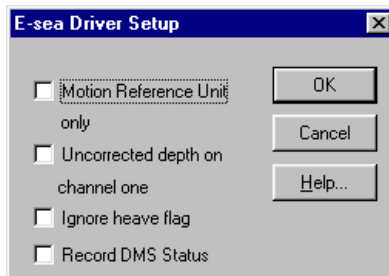

MRU Only means that you do not have the MRU connected through an echosounder. In this case, your Device Setup should select the Heave function and clear the Depth and Paper Annotation functions.

Uncorrected Depth On Channel One refers to the echosounder.

Ignore heave flag disarms the alarm in SURVEY when heave data is bad.

Record DMS Status: Does nothing at this time.

DEVICE OUTPUT STRINGS

2 comma-delimited strings at least 20 characters long.

- If it begins with "HR", it expresses Heave, Pitch and Roll
- If it begins with "E", it expresses Depth from channel 1.

DEPTH STRING

3rd Char	E	Error Flag
4th Char.	L	Followed by low frequency data
	H	Followed by high frequency data
22nd Char	H or L	2nd depth frequency follows

High Frequency is saved to Depth 1. Low Freq. is saved to Depth 2.

HPR STRING

Heave is read from 3rd char. and the value divided by 100.

Roll is read after the 1st comma and the value divided by 1000.

Pitch is read after the 2nd comma and the value divided by 1000.

DRIVER OUTPUT STRINGS

DEVICE WINDOW:

If doesn't read data, writes "Comm Error".

Writes original line, regardless of which line type.

Formats depth(s) to 2 dec. and writes:

Ch1=*HiFreqDepth* Ch2= *LoFreqDepth*

(Ch1=%5.2f Ch2=%5.2f)

Formats HPR data, each value to 2 dec. and writes:

"Heave=*Heave* Roll=*Roll* Pitch=*Pitch*"

("Heave=%5.2f Roll=%5.2f Pitch=%5.2f")

SERIAL PORT:

On Event sends "MP1<LF>".

Annotation String depends on event type:

Event Type	Annotation String
Start line	TA LineNameDBL MobileWaterDepth EventNumber, EventType<LF>
End Line or Manual Event	TA DBL MobileWaterDepth EventNumber, EventType<LF>

SPECIAL NOTES

EOL = <LF>

High and Low Freq. Depth can be displayed in the Data Display window.

Alarm: "Depth Error" caused by:

- Data String does not contain 2 commas.
- 3rd character of the depth string is "E" [error flag].

GENECHO.DLL

VERSION NUMBER

14.0.2.1

DEVICE NAME

HYPACK® Generic Echosounder Driver

DEVICE SETUP

Depth: Logs soundings or magnetometer data from this device.

Use for matrix update: Color-codes a matrix based on the data received from this device.

Paper Annotation: Annotates each event on the sounder's paper roll. (See Driver Output.)

Record device specific messages: Logs additional data related to the device to the Raw file. Each record will be identified by a driver-specific, 3-character tag.

DRIVER SETUP

FIGURE 1. Driver Setup Dialog

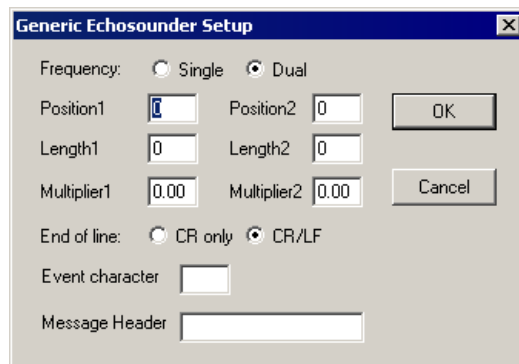

Frequency: Choose **Single** or **Dual** according to your device.

- **Position:** Enter the position in the string where the depth data begins.
- **Length:** The Length fields tell the driver how many characters to read for each depth value.
- **Multiplier:** Some echosounders output data in different units. Enter a multiplier that will convert the units of your output to survey units. (For example: if your echosounder outputs in centimeters and you are surveying in meters, your multiplier will be 100.) We recommend that you test for accuracy before you survey.

For Single Frequency, check the Single Frequency option and enter the first position, length and multiplier set.

For Dual Frequency, check the Dual Frequency option and enter 2 position, length and multiplier sets. It doesn't matter which frequency is described first.

End of Line: Indicate what appears at the end of each line of data—carriage return only or carriage return, line feed.

Event Character: Echosounders require a certain character to trigger an event. Find the character in the literature from the manufacturer and enter that character here.

Message Header specifies the start tag of the string to be read. This allows the driver to distinguish between multiple output strings.

DEVICE OUTPUT STRINGS

This is a generic driver. It should be able to handle any ASCII device output string with depth data.

DRIVER OUTPUT STRINGS

DEVICE WINDOW:

Writes original line.

Is Single Frequency, formats depth and writes:

```
"dep = Depth",  
("dep = %7.2f")
```

If Dual Frequency, formats depths and writes:

```
"dep1 = Depth1"  
dep2 = Depth2"  
("dep1 = %7.2f"  
"dep2 = %7.2f")
```

SERIAL PORT:

On Event: Outputs Event Character

INN455.DLL

Version Number: 9.0.4.3

Device Name: Innerspace 455 (and dual frequency 456)

DEVICE SETUP

Position: Logs position data from this device.

Only possible if you are using the *1PPS* option in the Driver Setup. In this case, the driver outputs position read from a GGA string.

Depth: Logs soundings or magnetometer data from this device.

Use for matrix update: Color-codes a matrix based on the data received from this device.

Paper Annotation: Annotates each event on the sounder's paper roll. (See Driver Output.)

Check both this one and the Send Event Mark option in the driver setup.

DRIVER SETUP

FIGURE 1. Driver Setup

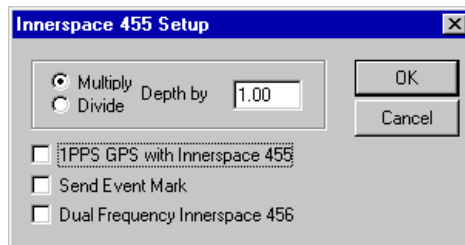

Multiply/Divide Depth by: The driver reads depth from the beginning of string (or after initial 10) to 5th char. and divides by 10. It then divides or multiplies by the user-defined factor.

1PPS GPS with Innerspace 455 instructs driver to read GGA string. If you want position from this driver, this must be selected.

Send Event Mark: Only works if *Paper Annotation* option is selected. *Paper Annotation* triggers the event, this option affects the annotation string. (See Driver Output Strings.)

Dual Frequency Innerspace 456 check if you are using this device.

DEVICE OUTPUT STRINGS

- If you are using it *with* the GPS, Inn455 and Inn456 should output IT-Multiple.
- If you are using it *without* the GPS, the device should output IT .

DRIVER OUTPUT STRINGS

DEVICE WINDOW:

If 456 is selected:

Formats depths to 2 dec. and writes:

```
"Hdepth=HiDepth Bad/OK"  
("Hdepth=%5.2lf %s")  
"Ldepth= LoDepth Bad/OK ",  
("Ldepth=%5.2lf %s")
```

If 456 is not selected, but 1PPS is selected.

Writes original line.

If the line read parses as a GGA, writes:

```
"Easting: X Northing: Y ",  
("Easting: %.2lf Northing: %.2lf ")  
"Time:Time HDOP=HDOP, N.sat=#Sats., GPSTime",  
("Time:%lu HDOP=%4.1lf, N.sat=%2i, %s")
```

If it doesn't parse successfully, writes "Unable to use this message".

If neither 456 nor 1PPS is selected:

Multiply/Divide Depth by: The driver reads depth from the beginning of string (or after initial 10) to 5th char. and divides by 10. It then divides or multiplies by the user-defined factor.

1PPS GPS with Innerspace 455 instructs driver to read GGA string. If you want position from this driver, this must be selected.

Send Event Mark: Only works if *Paper Annotation* option is selected. *Paper Annotation* triggers the event, this option affects the annotation string.

Dual Frequency Innerspace 456 check if you are using this device.

Regardless of 456 and 1PPS selections:

- **If Event Mark option and Paper Annotation options are selected:**
 - **If using Planned Lines writes:**
"\$E Line: *LineName* Depth: *Depth* Event: *-Event#* \015\012"
("\$E Line: %s Depth: %.2lf Event: %-5lu \015\012")
 - **If no Planned Lines, writes:**
"\$E Depth: *Depth* Event: *-Event#* \015\012"
"\$E Depth: %.2lf Event: %-5lu \015\012",
- **If Paper Annotation is selected but Event Mark is not,**
writes same as no planned lines.

SERIAL PORT:

Sends whatever you see on the device window *at Events*.

SPECIAL NOTES

Position only read from GGA which is only read when 456 is not selected and 1PPS is selected.

ERROR MESSAGE:

"Unable to use this message": When reading GGA strings, driver looks for <CR> and reads what's after. If there's nothing there, it displays this message.

"Bad Data": When neither 456 nor 1PPS is selected and the 6th char&1 indicates it's bad.

The following is an excerpt from the Innerspace manual regarding a annotation change:

"The string will be called the "EVENT" string and will consist of a start of string "\$" Hex 24 followed by an identifier "E" Hex 45 and then up to 40 ASCII characters followed by a CR LF pair Hex OD,OA.

"The Event string will generate a vertical line on the chart and the data will start at the bottom and will print vertically to the right of the event line. The printing will be left justified from the bottom of the chart and will vary in length."

INN448.DLL

Version Number: 15.0.0.0

Device Name: Innerspace 448

DEVICE SETUP

Depth: Logs soundings or magnetometer data from this device.

Use for matrix update: Color-codes a matrix based on the data received from this device.

Paper Annotation: Annotates each event on the sounder's paper roll. (See Driver Output.)

DRIVER SETUP

FIGURE 1. Device Setup

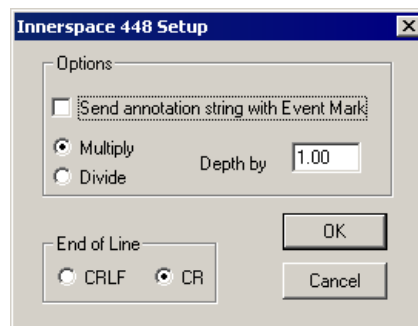

Send Annotation String with Event Mark includes a textual label with the annotation mark on your echosounder. The content of this string varies slightly according to the driver and whether you are using planned survey lines. If this option is not selected, your event mark will be unlabeled.

Multiply/Divide Depth by enables you to multiply or divide your depth readings by a constant number. Some devices output depths in units other than meters. In this case, enter a multiplier or divisor that will convert your depths to meters. If your device outputs meters, enter 1.00.

End of Line indicates whether lines end with a carriage return or carriage return and line feed.

DEVICE OUTPUT STRINGS

_DDDDDB

where:

D = (Depth)10

B = Bad Data flag (1=bad data)

Ex.:

```
_00300
_00300
_00310
_00310
```

DRIVER OUTPUT STRINGS

Sends event mark and, if the annotation string option is chosen in the driver setup, follows with textual annotation string.

DEVICE WINDOW:

“Depth=*Depth*” followed by “Bad” (if 6th character of the string is “1”) or “OK”

Depth is formatted to 2 decimals.

```
("depth=%5.2lf %s", depth, (bad_data)?"Bad":"Ok" )
```

On events:

- **No survey line:** writes

```
"\002\001NO LINE<CR>
\002\002<CR>
\002\003Event#<CR>
\002\005EventChar<CR>
\003"
```
- **With survey line,** writes:

```
002\001LineName<CR>
002\002Depth<CR>
002\003Event#<CR>
002\005Type<CR>
003
```

where:

Event Type Char	Event Type #	Defines
S	1	Start Logging
E	2	End Logging
M	3	Manual Event

SERIAL PORT:

On Event:

\006 out the serial port to mark the event.

If Annotation string option is chosen:

And if Start Line Event, writes Header:

- **No survey Line_writes:**
"\002\014LINE AZ:???? DATE: *mm-dd-yyyy*<CR>
\002\015JOB: *JobName*<CR>
\002\016PROJECT: *ProjectName*<CR>
\003"
- **With survey line**
"\002\014LINE AZ:*LineAzimuth* DATE: *mm-dd-yyyy*<CR>
\002\015JOB: *JobName*<CR>
\002\016PROJECT: *ProjectName*<CR>
\003"

Where Job Name and Project Name are read from Survey32.ini (after the user has defined them in SURVEY through OPTIONS-PROJECT INFORMATION).

For all event types, also includes same lines written to the Device Window.

SPECIAL NOTES

Annotation is an additional option on your echosounder. If you did not purchase this option, HYPACK® cannot annotate your echosounder. Before calling Technical Support about your annotation (or lack thereof), please check to make sure that option was actually purchased for your echosounder.

Saves last reading only.

GNU320MS.DLL

Version Number: 14.0.1.5

Device Name: Knudsen 320M Echosounder (Serial)

DEVICE SETUP

Position: Logs position data from this device.

Saves position data. Enables the echosounder to take position data directly from the GPS and outputs it with the depth reading. Compatible with all popular GPS units. Contact Knudsen for this configuration.

Depth: Logs soundings or magnetometer data from this device.

Reads depth data from \$PKEL99 strings or a numeric string (see Dev. Output)

Heave: Logs only heave from this device.

Enables the echosounder to take heave data directly from a Motion Reference Unit and outputs heave corrected depths. Compatible with TSS and Seatex units.

Reads heave data from \$PKEL99 strings or a numeric string (see Dev. Output)

NOTE: These are not our favorite options. If there is any problem with your raw data, we can probably help you if you have stored all of your raw data. If you select these and the echosounder has "pre-processed" the data, we may not be able to help.

DRIVER SETUP

None

DEVICE OUTPUT STRINGS

This driver supports any of the following:

- \$PKEL99, 50.50, 51.50, 55: First 2 fields after tag are depth1 and depth2. If the 18th char. Is not a "?", it reads heave starting at 13th character.

- 04.61,00.00,-----:First 2 fields are depth1 and depth2. If there's a 3rd field, it's heave.
- \$GPGGA,202838,4911.576113,N,12255.228339,W,2,06,1.3,0.63,M,-16.75,M,2,0305*47—position and quality data (latitude, longitude, utc, height, dop, sat, mode)

DRIVER OUTPUT STRINGS

DEVICE WINDOW:

If *Position* option is selected, formats to 2 decimals and writes:

X = X, Y = Y"

("X = %.2lf, Y = %.2lf")

If *Echosounder* is selected, formats to 2 decimals and writes:

"dep=Depth1, Depth2", ("dep=%5.2f, %5.2f")

If *Heave Comp.* is selected, formats to whole number and writes:

"heave=Heave" ("heave=%4.0f")

If *Paper Annotation* is selected:

- **With planned lines** writes:
"\$PKEL02,EventNumber TypeLineNumber Time
MobileWaterDepth<CR><LF>",
("\$PKEL02,%4.4lu %c%3.3i %s %4.1lf\r\n")
- **Without planned lines**, *LineNumber* is always "0".
- \$PKEL02,0001 M000 09:00:02 0.0

SERIAL PORT:

Device Open sends header:

\$PKEL26,Project: ProjectName Area: ProjectArea

\$PKEL27,Surveyor: Surveyor Boat: VesselName

"\$PKEL26,Project Job Area"<CR><LF>

"\$PKEL27,Boat, Surveyor"<CR><LF>

("\$PKEL26,% .20s % .20s % .20s\r\n") and ("\$PKEL27,% .30s
% .30s\r\n")

If *Paper Annotation* is selected:

- **With planned lines** writes:
LineName, EventNumber, Date, Time,
HighFrequencyDepth, LowFrequencyDepth, Easting,
Northing<CR><LF>",
("\$PKEL02,%4.4lu %c%3.3i %s %4.11f\r\n")
- **Without planned lines**, *LineNumber* is always "0".

KONGSBERGHPR410.DLL

Version Number: 9.0.1.6

Device Name: Kongsberg HPR410P

DEVICE SETUP

Position: Logs position data from this device.

Depth: Logs soundings or magnetometer data from this device.

Heading: Logs heading data from this device.

Speed: Displays speed data from this device.

Use for matrix update: Color-codes a matrix based on the data received from this device.

DRIVER SETUP

FIGURE 1. Driver Setup

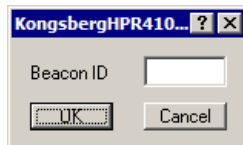

Beacon ID: Enter the Beacon Number you want to track.

DEVICE OUTPUT STRINGS

```
$PSIMSSB, time, beaconID, status, error_code,  
coordinate_system, orientation, sw_filter, x_coordinate,  
y_coordinate, depth, expected_accuracy, additional info,  
first_add_value, second_add_value, checksum, termination  
<CR><LF>
```

```
$PSIMSSB,130656.05,B48,A,Mi2,C,H,F,0.67,2.59,1.69,0.46,N<C  
R><LF>
```

The driver requires the coordinate system in Cartesian format.

DRIVER OUTPUT STRINGS

DEVICE WINDOW:

Writes the original string.

Formats depth, X and Y to 2 decimals and writes:

x=X y=Y dpt=*Depth*

SPECIAL NOTES

KNOWN SUPPORTED DEVICES

- Kongsberg/Simrad HPR/HiPAP
- Sonardyne USBL
- AAE Easytrak USBL

KONGSBERGNETWORK.DLL

Version Number: 16.1.2.0

Device Name: Kongsberg Network

DEVICE SETUP

Depth: Logs soundings or magnetometer data from this device.

Use for matrix update: Color-codes a matrix based on the data received from this device.

Paper Annotation: Annotates each event on the sounder's paper roll. (See Driver Output.)

Record device specific messages: Logs additional data related to the device. In this case, it logs bin files.

DRIVER SETUP

FIGURE 1. Driver Setup Dialog

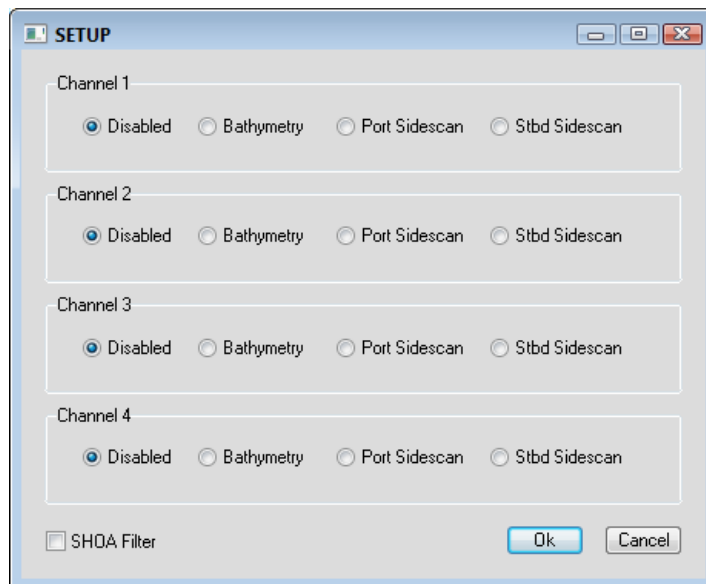

The Setup dialog of the Kongsberg Network driver allows you to select the information coming from each channel (Bathymetry, Port Sidescan, Starboard Sidescan, Disabled). There can only be one Port/Starboard Sidescan channel as well as two bathymetry

channels. If you has more than two bathymetry channels then the driver must be used twice with two channels assigned to bathymetry in each instance.

Once a channel is selected for sidescan the option will be unavailable for any other channel until the channel selected for that sidescan is disabled.

The software will get the range automatically from the RAW datagram for the sidescan and the maximum depth of the chart from the Surface Range set in the Network Interface for the depth echograms.

DEVICE OUTPUT STRINGS

Binary

DRIVER OUTPUT STRINGS

DEVICE WINDOW:

Scrolling Echogram.

SPECIAL NOTES

The system uses UDP packets to transmit data across the network. The port in the connect dialog of HARDWARE must be the same as the port in the Raw Data Interface in the EA400 software. This is the same port that is set in the Network Interface dialog in the EA400 software.

ver 11.1.0.8: User input changed from sampleRate to Range. The system outputs a message but doesn't tell us the range, so the user has to enter it. Also changed the HSCANTRANSFER to transfer only side scan channels eliminating the static in the side scan display.

NAUTRONIX.DLL

Version Number: 14.0.1.4

Device Name: Nautronix ATS Acoustic System

DEVICE SETUP

Position: Logs position data from this device.

Depth: Logs soundings or magnetometer data from this device.

Heading: Logs heading data from this device.

SURVEY uses the Course Made Good from the VTG, RMC or HDT message, or calculates the vessel orientation based on the change in position over time.

Use for matrix update: Color-codes a matrix based on the data received from this device.

DRIVER SETUP

FIGURE 1. Driver Setup

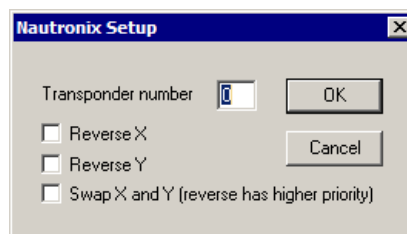

Transponder Number: Enter the transponder device number.

Reverse X: X is positive to port.

Reverse Y: Y is positive aft.

Swap X and Y: A Reverse option overrides the swap option.

DEVICE OUTPUT STRINGS

ATSII ASCII string:

Format	d t B E X Y D H P R	
	D	Date: dd mmm yyyy (month is 3 letters)
	T	Time: hh:mm:ss:sss
	B	B:5
	E	E:0
	X	X:X
	Y	Y:Y
	D	D:Depth
	H	H:Heading
	P	P:Pitch
	R	R:Roll
Sample Line	10 Jul 2008 15:15:39:621 B:5 E:0 X:50 Y:-100 D:749.0 H:0.0 P:0.0 R:0.0	

DRIVER OUTPUT STRINGS

DEVICE WINDOW:

Writes the original string.

Formats X, Y, and Z to 2 dec. and Heading to 1 dec. place, then writes:

"x=X y=Y z=Z hdg=*Heading*"

NAVISOUND210.DLL

Version Number: 17.1.0

Device Name: Navisound210

DEVICE SETUP

Depth: Logs soundings or magnetometer data from this device.

Use for matrix update: Color-codes a matrix based on the data received from this device.

Paper Annotation: Annotates each event on the sounder's paper roll. (See Driver Output.)

DRIVER SETUP

For dual frequency models, enter the offsets for the second transducer. In this case, HYPACK® SURVEY records ECM records.

DEVICE OUTPUT STRINGS

Maximum string length of 255 chars..

Contains "DA" and/or "DB", each immediately followed by a depth.

```
DA00000.00 m *****Channel 1*****
DB00000.51 m *****channel 2*****
BC00.0dB
*
DA00000.00 m
DB00000.50 m
BC00.0dB
*
DA00000.00 m
DB00000.51 m
BC00.0dB
*
DA00000.00 m
DB00000.51 m
BC00.0dB
*
```

DRIVER OUTPUT STRINGS

DEVICE WINDOW:

Writes original line.

If either depth is non-zero, formats depth(s) to 2 dec. and writes:

```
"dep=Dep1 dep2=Dep2",  
("dep=%5.2f dep2=%5.2f")
```

On Event, formats depth to 2 dec. and writes:

```
"TX$LineNo: LineNumber DotNo: EventNumber Depth: Depth  
Time<CR><LF>EM3EM1<CR><LF>"  
("TX$LineNo: %d DotNo: %lu Depth: %0.2f %s\r\nEM3EM1\r\n")
```

SERIAL PORT:

On Event, formats depth to 2 dec. and writes:

```
"TX$LineNo: LineNumber DotNo: EventNumber Depth: Depth  
Time<CR><LF>EM3EM1<CR><LF>"  
("TX$LineNo: %d DotNo: %lu Depth: %0.2f %s\r\nEM3EM1\r\n")
```

SPECIAL NOTES

DEVICES SUPPORTED

- Navisound 210
- Navisound 215

NAVISOUND515.DLL

The RESON Navisound 515 is a dual frequency echosounder that comes equipped with both Ethernet and serial interfaces. The appealing aspects of the Ethernet interface are:

- One less need for hard-to-find serial ports
- Faster data rates
- Ability to output and log the acoustic echogram which allows you to re-digitize the depths in the 32-bit SINGLE BEAM EDITOR.

Version Number: 14.0.1.3

Device Name: Navisound515

DEVICE SETUP

Depth: Logs soundings or magnetometer data from this device.

Use for matrix update: Color-codes a matrix based on the data received from this device.

Paper Annotation: Annotates each event on the sounder's paper roll. (See Driver Output.)

DRIVER SETUP

FIGURE 1. Driver Setup

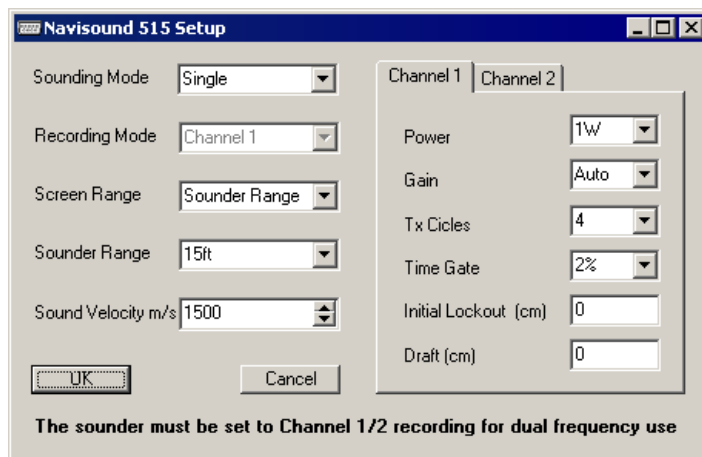

Sounding Mode:

- **Single:** Reads one channel.
- **Multiplexing:** Reads 2 channels.

(The NaviSound 515 echosounder is basically a single channel echosounder, but it has been enhanced with a range of functions and an extra transmit section.

By switching between two sets of parameters and at the same time switching between two transducers, the echosounder alternates its measurements. While this alternation reduces the effective sounding rate at each transducer to half, it also provides all the benefits of dual-frequency measurements.)

Recording Mode:

- **Single:** Select 'Channel 1' or 'Channel 2'.
- **Multiplexing:** Reads 2 channels. Select 'Channel 1/2'.

Screen Range: Depth range for display only.

Sounder Range: Select the maximum depth in your project area. For optimum performance, the echosounder will automatically alter the number of soundings per second for the selected depth value.

Sound Velocity controls both the HYPACK® and navisound box display.

- **In shallow water** (less than 20 meters) the sound velocity may be determined using the built-in bar check calibration facility (see Technical Settings menu). If a bar check has already been carried out, the velocity of sound value will have been entered automatically.
- **In deeper water** (greater than 20 meters) an average value for the velocity of sound must be computed, and then entered manually.

For Each Channel:

- **Power:** Level at which the sounder transmits
- **Gain:** Receiver amplifier. Device manual suggests using 7 and adjusting to find the best results for your project conditions.
- **TX Cycles** (Transmit Cycles): Length of the transmitting pulse.
 - For hard bottoms, use 4.
 - For soft bottoms use 16.
 - If the bottom type is unknown, begin with 16 and adjust if necessary.
- **Time Gate:** A percentage of the selected depth range. The time gate essentially acts as a quality control 'window' with soundings labelled as 'good quality' if they fall within the time gate, the position of which is determined by the last measured depth. If a sounding falls outside the time gate it is not rejected, but the quality is automatically adjusted and the depth is considered to be of 'poorer quality'. The quality factor is output

to external devices together with the depth data when using the NaviSound format. The time gate is selected according to the seabed type.

- **For a gentle undulating seabed** the time gate should be set very small.
- **For a mountainous seabed** the time gate should be set large.

FIGURE 2. Time Gate Diagram

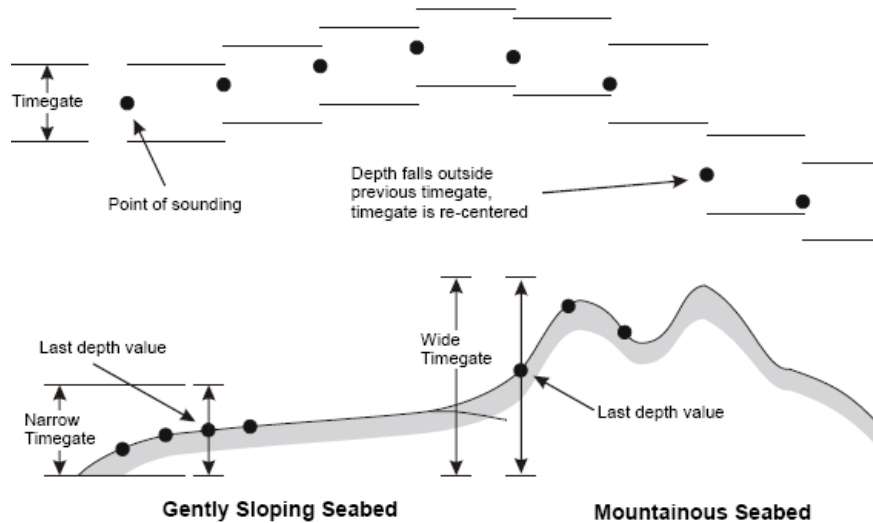

- **Initial Lockout** filters out false depths the water column. It can be used in two ways:
 - To filter out false depth values due to turbulence and reflections from the ship’s hull.
 - To force the echo sounder to track the true bottom in areas where the bottom may be covered by liquid mud or sea grass.

FIGURE 3. Initial Lockout Diagram

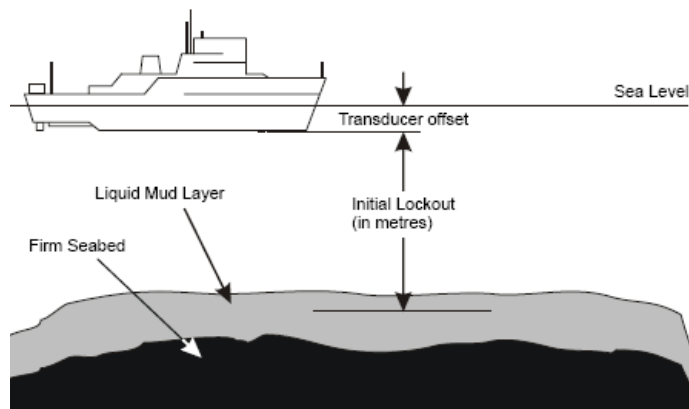

NOTE: **NOTE:** The initial lockout should only be used to force the echosounder to track the true bottom if the bottom conditions are known, e.g. the area that is being re-surveyed. Otherwise it may mask out shallow water readings.

Tip:

To determine the proper setting, set to 20cm and test. If you get false depth readings increase the value in 0.1 meter steps until the false readings are rejected.

- **Draft:** Always in centimeters. Distance from the water line to the transducer.

DEVICE OUTPUT STRINGS

The sounder must be set to channel 1/2 recording for dual frequency use.

GT xDDDDDDddddddshhhhoorrm!sss...up to 200 bytes...ss<cr><lf>

Where:

x	Section number
DDDDDD	Channel 1 instant depth with heave (cm) (Max 640m)
dddddd	Channel 2 instant depth with heave (cm) (Max 640m)
shhhh	Heave (cm) where s is the sign = + or -
ooo	Image Offset (m)
rr	Paper range in meters: 01-11 where: 1=5 2=10 3=20 4=50 5=100 6=200 7=400 8=800m 9=1200m 10=2000m 11=2500m

m	Recorder mode 0-4 where: 0=Ch1 1=Ch2 2=Ch1 + 2 3=Ch1/2 4=Ch-1/2
!	Separator
sss-sss	Up to 213 sample bytes, each with pixels.

DRIVER OUTPUT STRINGS

Acoustic echogram data (*.bin files) in addition to the digitized depths in the HYPACK® RAW format files.

DEVICE WINDOW:

Shows scrolling graph of the echogram w/ text box on the right. (In the 32-bit SINGLE BEAM EDITOR, you can also display the data in the Echogram window.)

FIGURE 4. Sample Device Window

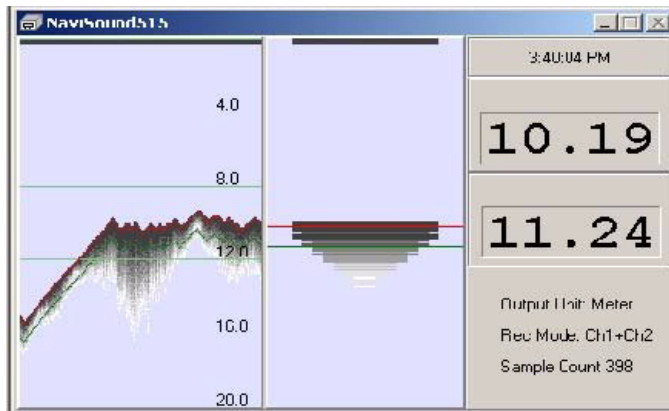

To turn the individual beam display on/off, right-click in the display and select 'Beam'.

To turn the text display on/off, right-click in the display and select 'Status'.

To access the driver setup dialog, right-click in the graph and select 'Setup'.

NOTE: You may change your settings *only when you are not logging*.

IMPORTANT: Modifying your configuration from SURVEY is less reliable than configuring in the device and from HYPACK® HARDWARE. *If you change your options from SURVEY, verify that they have taken effect.*

SERIAL PORT:

Event# Time DBL

SPECIAL NOTES

ADDED INFORMATION

http://www.hypack.com/new/portals/1/PDF/sb/07_09/Navisound%20515.pdf

CONNECTION INFORMATION

NAVISOUND SETUP

When using Ethernet communication, run a network cable from the LAN card on your PC to LAN Port 1 on the 515 as shown here.

Using the Menu button on the Navisound box, select Communication and choose COM 1 or Ethernet.

NOTE: COM1 is the *only* serial port that works.

The driver initially provides the most common network settings by default.

COM1 SETTINGS:

- Select Baud rate, parity, etc..
- Set COM1 Input Type: to Remote or All. Remote is best because it eliminates GGA and GGL messages.
- COM1 Output Type: Graphic Trace
- Com1 Data When : Power On (recommended) or First Command

ETHERNET SETTINGS:

On your device, select COMMUNICATION-LAN-LOCAL and set your IP address to 192.168.0.6,

- Local Address: Accept default settings and use them in HYPACK® Driver Connection:
 - LAN Tx Port: 1036
 - LAN Rx Port: 1037
 - Set LAN Output Remote IP4=6
 - LAN Input Type=Remote
 - LAN Output type =Graphics Trace
 - LAN Data When: power On
 - LAN Loop th. = None
- Remote Address:
 - LAN RemoteIP1-3; Same as the Local Address.
 - LANRemoteIP4: 11

GRAPHIC SETTINGS:

Select COMMUNICATION-LAN-LAN Format menu and set the Lan Output type as 'Graphics trace'.

- Numeric Units: Survey Distance Units.
- Graphic Units: Display purposes only, but suggest it should match numeric units.
- Serial: The PC COM port where the Navisound is connected and same Baud Rate, etc. as set in the Navisound box.
- Network:
 - Protocol: UDP
 - Role: Server
 - LAN Tx Port: 1036
 - LAN RxPort: 1037

**HYPACK®
CONNECTION
SETTINGS**

**SURVEY
COMPUTER
SETTINGS**

Disable FIFO buffer for the COM Port connected to the Navisound.

1. Select My Computer-Properties [Dev Mgr]-Ports
2. Rt-click on the COM port HYPACK® is using to connect and select Properties.
3. Go to the FIFOs tab and clear “Use FIFO buffers” option.
4. Click [OK] and exit the Device Manager.
5. Click [OK] to return to HYPACK®.

ODOMCV3.DLL

REPLACES ODOM_CV3 AND ODOMCV_3 4/23/15

Version Number: 17.1.1

Device Name: Teledyne Odom CV Series

DEVICE SETUP

Depth: Logs soundings or magnetometer data from this device.

Heave: Logs only heave from this device.

Record device specific messages: Logs additional data related to the device to the Raw file. Each record will be identified by a driver-specific, 3-character tag.

This driver stores the raw datagrams from the sounder. Since the datagrams contain so much information the data is stored in a separate binary file (*.BIN) with the same Prefix as the RAW file name.

Use for matrix update: Color-codes a matrix based on the data received from this device.

Paper Annotation: Annotates each event on the sounder's paper roll. (See Driver Output.)

DRIVER SETUP

FIGURE 1. Driver Setup

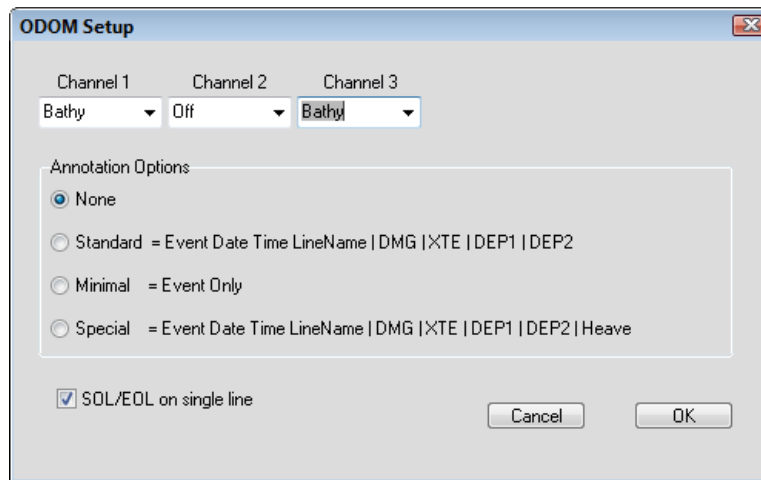

Channel 1-3:

- **MK3:** Can use channel 1 or 2 or both. One for the Bathy and the other for the Side Scan.
- **CV3:** Can use all 3 channels. Channel 2 should always be Bathy High or Low. Channels 1 or 3 can also be Port or Starboard Side Scan.

(The driver defaults to Channel 1 = Bathy.)

Annotation Options: Choose the annotation string (if any) as defined in the setup dialog.

Start of Line/ End OR Line on a single line:

DEVICE OUTPUT STRINGS

Reads the GGA message coming in from the ODOM and removes the header. Once the header is removed the data is sent back out a UDP port so that the GPS driver can be used to read in the GGA message.

DRIVER OUTPUT STRINGS

Sends annotation across the network according to the selection in the Setup dialog.

DEVICE WINDOW:

Scrolling echogram display.

FIGURE 2. Sample Echogram Display

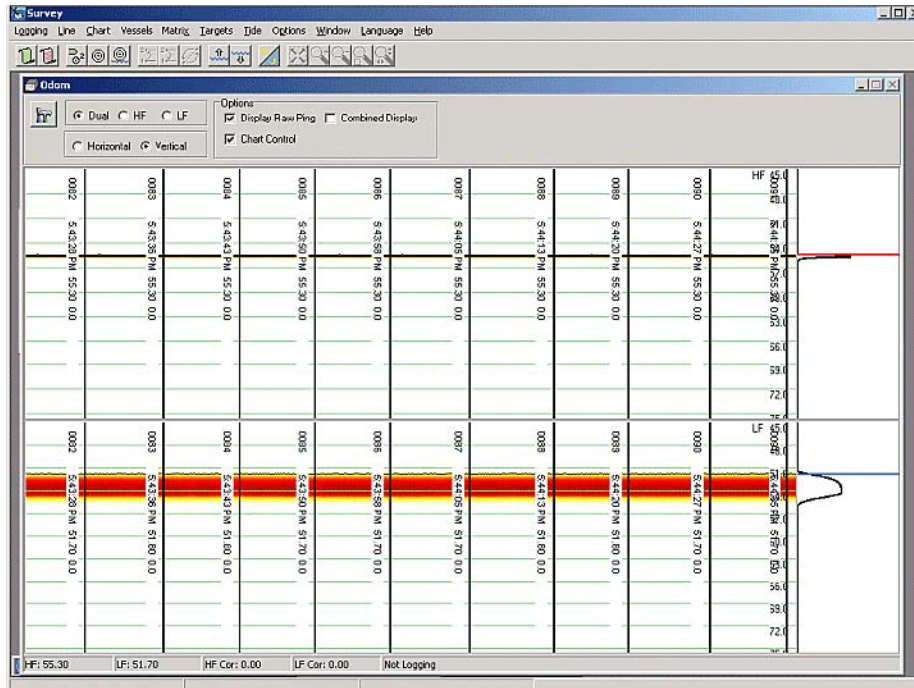

If you have selected dual in the Driver Setup, you can choose to display either frequency or both in the Device Window. (You cannot choose to display a frequency in SURVEY that you have excluded in your hardware configuration.)

Horizontal/Vertical: If you are displaying both frequencies (Dual is selected) they can be tiled vertically or horizontally in the window.

Display Raw Ping displays the current ping to the right.

Combined Display displays the current ping from both frequencies.

Chart Control automatically starts and stops the chart in coordination with the logging function of HYPACK® SURVEY.

The tool icon calls a second display showing the status of each frequency.

SPECIAL NOTES

CONNECTIONS

This device passes very large amounts of data over a network cable. In the HARDWARE Connect dialog:

- Connect = **Network Port** (Make sure Windows Firewall is Disabled, especially in Vista)
- Protocol = **UDP**
- Role = **Server**
- Port = **1600**
- Write Port = **1601**

With this setup the echosounder constantly sends data over the CAT-5 network cable.

- **If the device is connected directly to the computer** the cable should be a crossover cable. This cable can be bought at any computer store.
- **If the device is connected to a hub** use a standard CAT-5 cable.

When configured to get GPS through the sounder, the driver adds one to the Write Port of the sonar and uses that number (in the normal case, 1602) for the GPS read port.

OTHER NOTES

- The 32-bit SINGLE BEAM EDITOR is enhanced to provide a display for this data.
- If the device is connected directly to the computer, use a cross-over cable. (Red cable from Echotrac.) If it is connected through a network hub, use a straight network cable between the device and the hub.
- **Reads** the GGA message coming in from the ODOM and remove the header. Once the header is removed the data is sent back out a UDP port so that the GPS driver can be used to read in the GGA message. The ODOM CV series sonars only pass the GGA message for now, but the driver will forward any valid NMEA message in this manner if in the future ODOM decides to send more across the Ethernet. This allows a serial GPS to be connected to the ODOM CV series sounder and passed to the computer in one network cable. Typically, the port settings are as follows:
 - **Sounder Read Port:** 1600
 - **Sounder Write Port:** 1601
 - **GPS Read Port:** 1602 (Driver uses sonar write port + 1.)

- **eChart** only annotates when there's only one enabled adapter and it is connected to the Odom.

ROSSSMART.DLL

Version Number: 14.0.1.6

Device Name: Ross Smart Echosounder (Serial)

DEVICE SETUP

Depth: Logs soundings or magnetometer data from this device.

Use for matrix update: Color-codes a matrix based on the data received from this device.

Paper Annotation: Annotates each event on the sounder's paper roll. (See Driver Output.)

DRIVER SETUP

FIGURE 1. Driver Setup

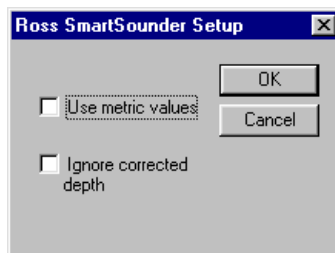

Use Metric values and **Ignore Corrected Depth:** Determines how to parse the string. The raw data string outputs meters and feet, corrected and uncorrected depths. It reads different fields of the string for the depths depending on which of these options are checked.

DEVICE OUTPUT STRINGS

```
$SDRSL,200,KH,11.4,fHC,11.4,f,3.47,MHC,3.46,M,28,KH,11.1,fHC,11.0,f,3.37,MHC,3.36,M
```

Depth	Field	Content
	1	\$SDRSL
Depth 1	3	foot, corrected
	5	foot, uncorrected
Depth 2	7	metric, corrected
	9	metric, uncorrected
	13	foot, corrected
	15	foot, uncorrected
	17	metric corrected
	19	metric, uncorrected

DRIVER OUTPUT STRINGS

DEVICE WINDOW:

Writes original string.

Formats depths to 1 decimal and writes:

"dep=dep1, dep2"

("dep=%5.1f, %5.1f")

Start log Event:

"\$R,dd,mm,yyyy,LineNumber_hhmm<CR><LF>" where

"dd,mm,yyyy" is the date and "hhmm" is the time in hrs. and min.

("\$R,%s,%s,%s,%3.3i_%c%c%c%c\r\n")

Formats *EventNumber* to 4 decimals.

End Log Event:

"\$E,EEventNumber,time<CR><LF>

("\$E,%c%4.4lu,%s\r\n")

Manual Event: Same as End Log Event except "M" in place of "E".

"\$E,MEventNumber,time<CR><LF>

SERIAL PORT:

Start Log Event:

"\$R,dd,mm,yyyy,LineNumber_hhmm<CR><LF>" where

"dd,mm,yyyy" is the date and "hhmm" is the time in hrs. and min.

("\$R,%s,%s,%s,%3.3i_%c%c%c%c\r\n")

Formats *EventNumber* to 4 decimals.

End Log Event:

"\$E,EEventNumber,time<CR><LF>

"\$S<CR><LF>"

("\$E,%c%4.4lu,%s\r\n"

"\$S\r\n")

Manual Event: Same as End Log Event except "M" in place of "E".

"\$E,MEventNumber,time<CR><LF>

SPECIAL NOTES

1/11/02: Works with 2 beams.

5/3/13: If the second depth is 0, the number of depths is set to 1.

SMARTSWP.DLL

Version Number: 15.0.0.1

Device Name: Ross SmartSweep

DEVICE SETUP

Depth: Logs soundings or magnetometer data from this device.

Record device specific messages: Logs additional data related to the device to the Raw file. Each record will be identified by a driver-specific, 3-character tag.

This driver logs the speed of sound in string with an SOS tag immediately following each EC2 or ECM record in the following format:

SOS dn t s

where:

SOS	Tag
dn	device number
t	time (sec. after midnight)
S	Speed of sound

Sample String: SOS 1 50310.044 4815.0

Record Raw Messages: Logs the data string to the raw file as it is originally received from the device.

Use for matrix update: Color-codes a matrix based on the data received from this device.

Paper Annotation: Annotates each event on the sounder's paper roll. (See Driver Output.)

DRIVER SETUP

FIGURE 1. Driver Setup

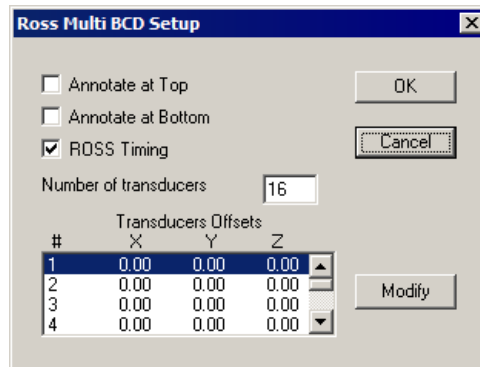

Annotate at Top and **Annotate at Bottom**: affects only manual events. The Event Number is written at the top or bottom of the roll.

Ross Timing (Default = on): The driver uses the time information from the RSW_T message. It ignores messages in the RSW format (no _T) and you get a device timeout in SURVEY.

If unselected, it uses time tags from the HYPACK® Veritime Clock model. (This is how the older SmartSweep.DLL worked).

Transducer offsets: Enter the number of transducers in your system, then the measured offsets of each one. *The order in which the information is entered must match the sequence in which the echosounder system reports the depths to the computer.* Select a transducer in the Driver Setup dialog and click [Modify]. The Offset Setup dialog will appear for you to enter the offsets for the selected transducer. Typically, you would begin with number 1, enter the offsets then click [Next] to proceed to the next transducer.

BEWARE!

Be careful with depth offsets. They are usually set as draft in the sounder and you should not compensate for draft twice. Typically, the hull-mounted transducer might have a depth offset of 0, indicating that draft is corrected at the sounder. The rest of the transducers (boom-mounted) would then have negative offsets, indicating they are slightly above the hull-mounted transducer.

DEVICE OUTPUT STRINGS

```
$SDRSW, cc, xxx.x, xxx.x, xxx.x, xxx.x, f, ssss.s<CR><LF
```

where:

\$SDRSW	Beginning of line
cc	Number of transducer soundings in string

xxx.x	Soundings—1 per transducer
ssss.s	Speed of Sound
F<CR><LF>	End of Line

DRIVER OUTPUT STRINGS

DEVICE WINDOW:

Graphs depths of each transducer.

SERIAL PORT:

*Before version
15.0.0.1:*

On events:

- **Start Line event** sends: `$R,dd,mm,yyyy,LineName<CR><LF>`
- **End Line event** sends: `$S<CR><LF>`
- **Manual event** sends:
 - Ann. Top only sends: `"$E,EventNumber, <CR><LF>"`
 - Ann. Bottom only sends: `"$E,, EventNumber <CR><LF>"`
 - Ann. Both sends: `"$E, EventNumber, EventNumber <CR><LF>"`
 - If neither checked, sends nothing.

*Beginning in Ver
15.0.0.1:*

Start Log Event:

`"$R,dd,mm,yyyy,LineNumber_hhmm<CR><LF>"` where
 "dd,mm,yyyy" is the date and "hhmm" is the time in hrs. and min.
 (`"$R,%s,%s,%s,%3.3i_%c%c%c%c\r\n"`)

Formats *EventNumber* to 4 decimals.

End Log Event:

`"$E,EventNumber,time<CR><LF>"`
`"$S<CR><LF>"`
 (`"$E,%c%4.4lu,%s\r\n"`
`"$S\r\n"`)

Manual Event: Same as End Log Event except "M" in place of "E".
`"$E,MEventNumber,time<CR><LF>"`

SPECIAL NOTES

- Supports as few as 2 transducers.
- If no line file is loaded, this driver doesn't annotate.

- Driver has a menu in SURVEY that expands and contracts the scale of the graph by a factor of 2 and allows you to reset the range.
- The time of your unit should be on local time, with minutes and seconds synched to UTC. If you are synching to UTC, then we need to add a time offset between UTC and local.

KNOWN SUPPORTED DEVICES:

Ross Labs. Smart Sweep

SONARMITE.DLL

Version Number: 16.1.2

Device Name: Sonar Mite Echosounders (Standard and DFX)

DEVICE SETUP

Depth: Logs soundings or magnetometer data from this device.

Heave: Logs heave, pitch and roll data from this device.

Use for matrix update: Color-codes a matrix based on the data received from this device.

DRIVER SETUP

None.

DEVICE OUTPUT STRINGS

Standard Sonar-Mite string:

ID Depth Roll Pitch Heave

```
(sscanf( &line[0], "%d %lf %lf %lf %lf", &id, &dep, &roll, &pitch, &heave);)
```

The driver expects an integer for the ID and doubles for the Depth, Pitch, Roll and Heave.

SonarMite DFX:

ID HDepth LDepth wtemp battery flags<cr><lf>

ID: The ID of the instrument (0..7)

HDepth: Current high frequency measured depth (m)

LDepth: Current low frequency measured depth (m)

wtemp: water temperature (deg. C)

battery: battery condition (v)

flags: binary data seen flags: 1=high, 2=low, 4=wtemp, 7=all seen

NOTE: If no transducer is seen or out of water, the output will appear as a string of ID + 5 nulls at 1 sec. timeouts. In

normal operation, the 5 numbers are reported at 0.5 sec. intervals.

DRIVER OUTPUT STRINGS

DEVICE WINDOW:

Scrolling display of:

"depth = *Depth*

Heave = *Heave*, Pitch = *Pitch*, Roll = *Roll*"

DATA DISPLAY WINDOW:

Configurable for Data Quality and Battery Voltage

SPECIAL NOTES

7/24/06: Added device open that contains geodesy and returns serial driver.

10/09: Converts depth from meters to project units.

3/5/14: Quality data stored in Depth 2 location of raw files.

Version16.1.2: supports SonarMite DFX (dual freq. SonarMite which outputs DFX strings.)

SONARLITE.DLL

Version Number: 15.0

Device Name: Sonar Lite Echosounder

DEVICE SETUP

Depth: Logs soundings or magnetometer data from this device.

Use for matrix update: Color-codes a matrix based on the data received from this device.

DRIVER SETUP

None

DEVICE OUTPUT STRINGS

SonarLite ASCII format: We read the 'M' record which is depth in meters.

M 1.65

DRIVER OUTPUT STRINGS

DEVICE WINDOW:

Writes the original string followed by:

Depth = *Depth*

SONTEK_M9.DLL

Version Number: 17.2.2

Device Name: Sontek M9 HS

DEVICE SETUP

Position: Required for DVL (Doppler Velocity Logging) positioning (bottom-tracking)

Depth: Logs sounding data. This driver logs the five active beams to multi-transducer (ECM) records in the Raw file.

Heading: Logs heading based on the change in position over time.

IMPORTANT: *Log heading from only one device.* If you are logging heading from your GPS, do not check this option for the M9 HS.

Heave: Logs pitch and roll data.

Generate Output Messages: Generates a YDFF file using the root name of the HYPACK® Raw file.

Record device specific messages: Required to record the sound velocity at the sensor depth.

Use for matrix update: Color-codes a matrix based on the data received from this device.

DRIVER SETUP

MAIN TAB

FIGURE 1. SonTek M9 HydroSurveyor Driver Setup

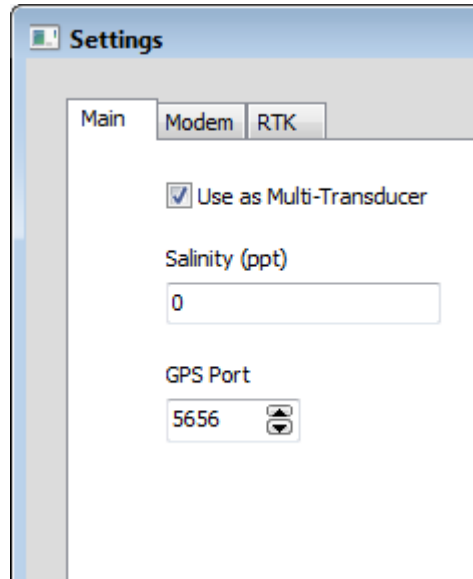

Use as Multi-transducer records all 5 beams as multi-transducer records (*.ECM) in the Raw files. Deselected, the driver reports only the nadir beam to an EC1 record.

Use for matrix update: Color-codes a matrix based on the data received from the five active beams.

Salinity (ppt) is used to calculate the speed of sound. The driver logs SVP records to the Raw file.

Tip:

The driver defaults to 0, which is appropriate for fresh water surveys. An appropriate default for seawater surveys is 35 ppt.

GPS Port: Required to connect the SonTek system with HYPACK®. This is the UDP Port from which your GPS driver reads the data. In this configuration, the GPS data comes through the base station. The SonTek M9 HS driver then broadcasts the GPS data *within Windows*®, to the GPS driver at this port.

NOTE: The GPS driver must be configured as a UDP Server on this port. (You can leave the Write Port blank.)

MODEM TAB

The **Wireless Radio Modem** configuration uses two base stations: one for connecting the HydroSurveyor and a GPS antenna, and the other for RTK tides. Additionally, a USB antenna on your computer registers as a serial device (COM port). The GPS data

comes through the base station, which then broadcasts the data back out the UDP GPS Port specified in the driver.

The Modem tab, enables you to configure your system, even if there are multiple HydroSurveyors.

FIGURE 2. SonTek Driver Setup—Modem Tab

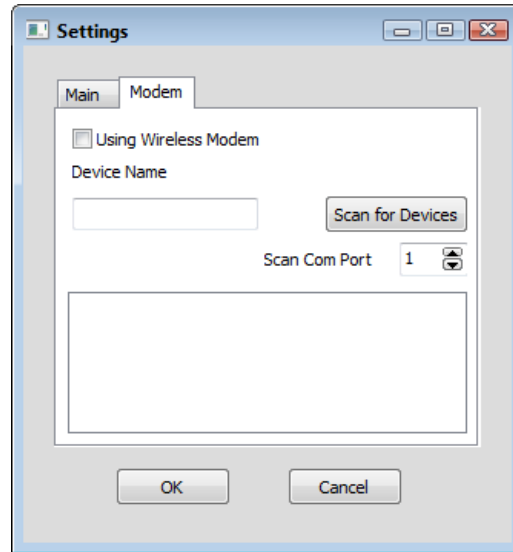

1. **Check Using Wireless Modem.**
2. **Set the COM Port** for the modem. (Use COM Query.)
3. **Click [Scan for Devices].** The HydroSurveyor(s) should appear in the list below.
4. **Select the HydroSurveyor** for this driver configuration to populate the Device Name.
5. **Click [OK].**

RTK TAB

For RTK positioning, enter the Latitude, Longitude and Ellipsoid Height of the RTK base station.

1. **Enter the COM Port for the base station.**
2. Click **[Read Position from Base]**. The base station coordinates populate from the base station signals.

BEWARE!

Due to HDOP error, these values are likely to be *less accurate than if you manually enter the known coordinates* of the base station. However, when the Read Position button populates the coordinate fields, it confirms communication with the base station.

3. **[Send to Device]** sends the base-station coordinate system to the HydroSurveyor where the RTK calculations occur.

FIGURE 3. SonTek Driver Setup—RTK Tab

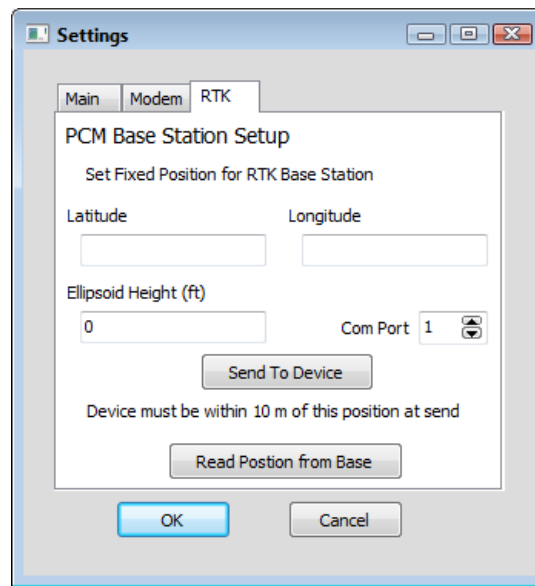

DEVICE OUTPUT STRINGS

SonTek HydroSurveyor outputs a standard network output message.

DRIVER OUTPUT

When you select the **Generate Output Messages** function, the driver generates a YDFF file using the root name of the raw file. YDFF is the native SonTek format.

DEVICE WINDOW

DEPTH TAB

A chart with the last 100 depths. In addition, the window displays the uncorrected depths in the sensor head diagram.

The graph can scale automatically, but you can also manually set the depth range. You may also modify the trace color for each beam. (Click its color box and choose the new color from the color dialog.)

To set vertical scale for the depth graph, use the Chart Scaling options.

1. **Click [Chart Scaling]** to access the configuration dialog.

FIGURE 4. Chart Scaling Dialog

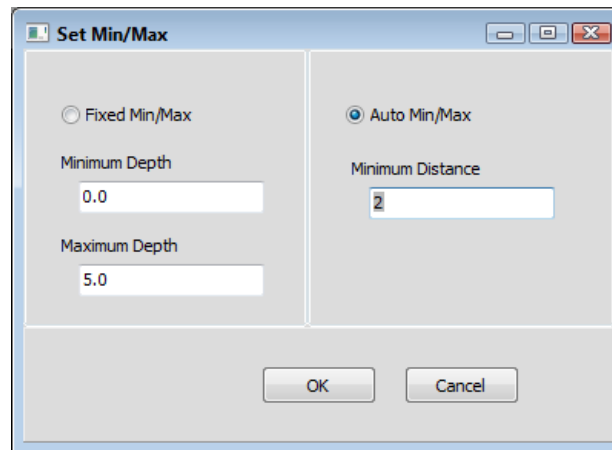

2. **Set your options and click [OK].**
 - **Autoscaling:** Select the Auto Minimum/Maximum option. The Minimum Distance option defines the smallest depth range you want to display.
 - **Manual Scaling:** Select the Fixed Minimum/Maximum option and enter the depth range you want to display.

FIGURE 5. SonTek M9 HS Device Window—Depths Tab

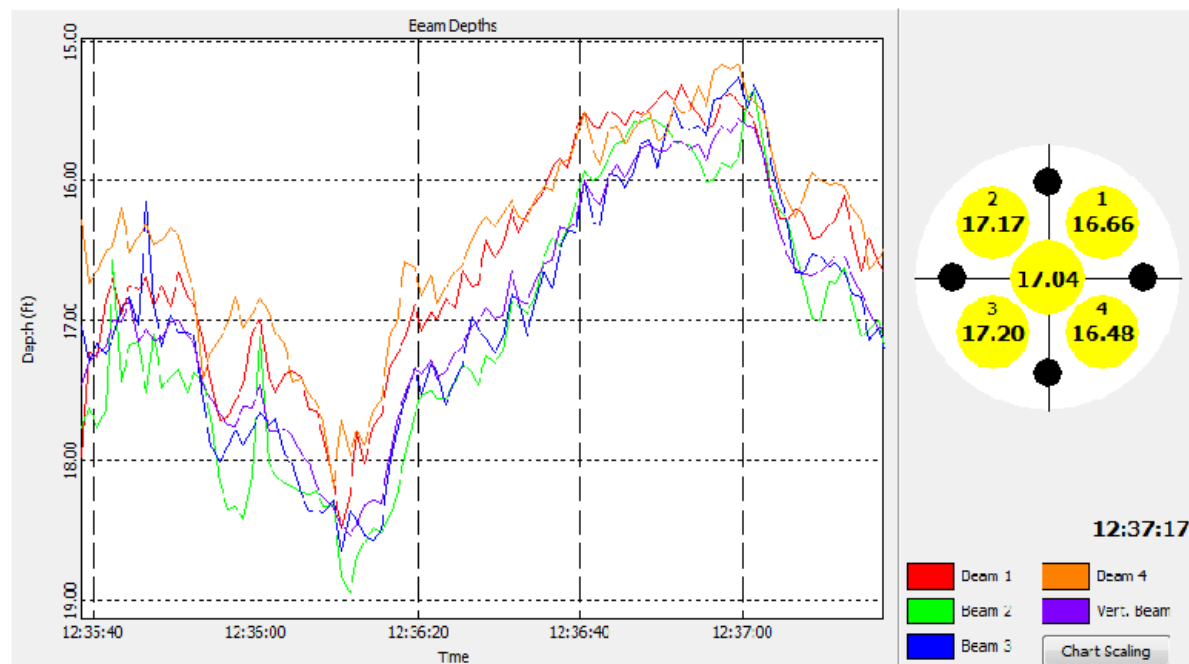

BEAM PROFILE TAB

The Beam Profile tab shows the current velocities (corrected for the bottom track velocity) and a beam amplitude profile along its path to the bottom.

On the right, the circular display shows the velocity of the current relative to the boat.

The optional amplitude profile display is useful to QC check your depths. The beams should descend smoothly together until they reach the bottom.

To show the amplitude profile, check the Show Beam Amplitude option.

To choose the value for the graph displays, select from the drop-down menu options.

To customize the color settings, the Colors icon accesses the standard Colors dialog. The colors configured from the Profile window affect only the Profile display.

FIGURE 6. SonTek M9 HS Device Window—Beam Profile Tab

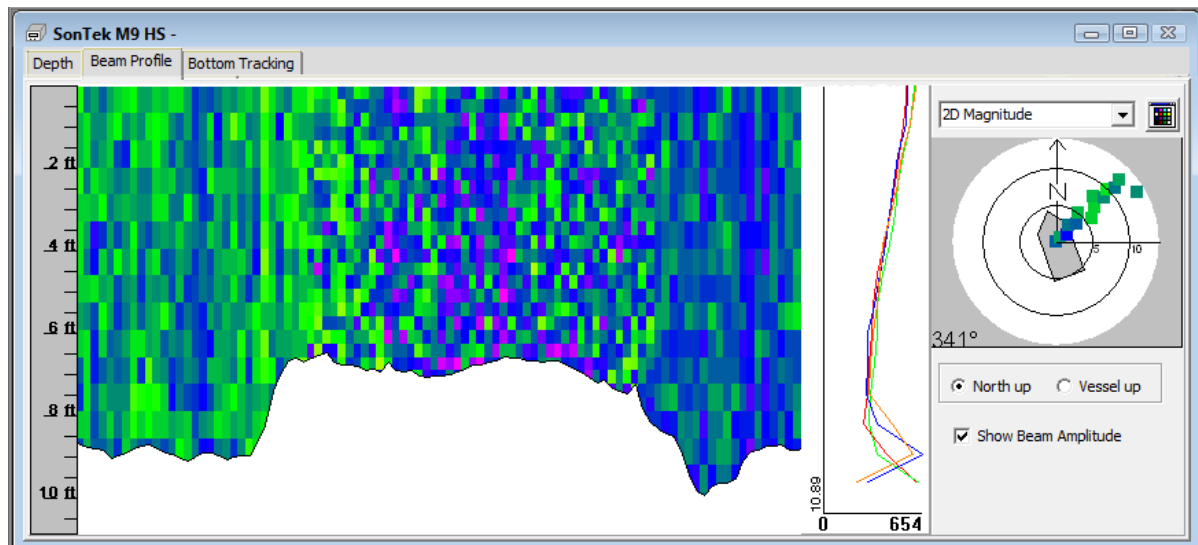

BOTTOM TRACKING TAB

You can use SonTek M9 HS bottom tracking for positioning in areas where you are likely to lose GPS signal.

Tip:

When using bottom tracking, it is useful to assign the HydroSurveyor and GPS to *separate mobiles*. This enables you to compare the positioning of each system and prevents the vessel display in the HYPACK® SURVEY Map window from jumping as you change systems.

During SURVEY, just before you lose GPS signal, check the **Use Bottom Tracking** check box in the Bottom Tracking tab of the Device window. When you regain GPS signal, clear the same check box.

IMPORTANT: We recommend using the bottom tracking only when you need it. Its position is relative to the last position allowing errors to propagate over extended periods of time.

The Device Window display in the Bottom Tracking tab shows the GPS position (blue) and the bottom tracking position (red).

FIGURE 7. SonTek M9 HS Device Window—Bottom Tracking Tab. GPS Position (blue) and the Bottom Tracking Position (red)

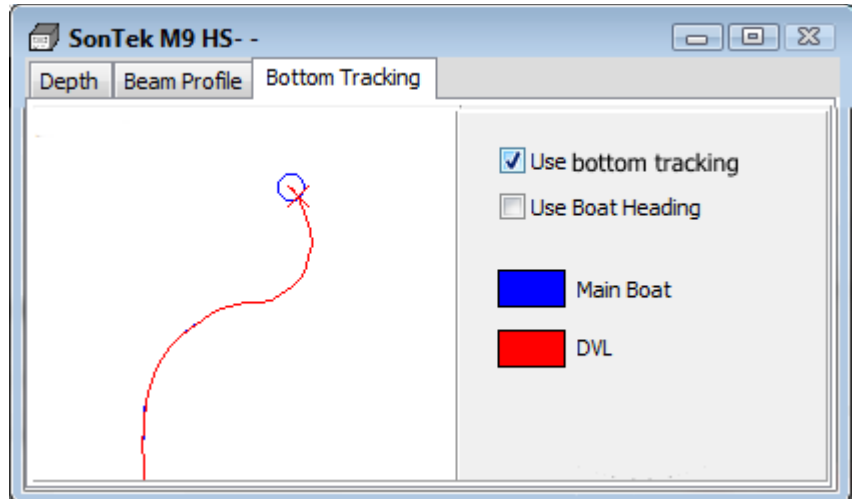

DATA DISPLAY:

Options to display the raw and corrected depths for each beam.

FIGURE 8. SonTek HydroSurveyor Data Display

Sontek M9 Corr. Depth[1]	14.20
Sontek M9 Depth[1]	20.06

SPECIAL NOTES

Data can be processed in either the 32-bit SINGLE BEAM EDITOR, 64-bit SINGLE BEAM EDITOR or 64-bit HYSWEEP® EDITOR.

IMPORTANT: The Sontek_M9 driver name *must* appear in the raw header file to be properly recognized by the editor programs.

You can view the edited LOG file from the 32-bit SINGLE BEAM EDITOR in the ADCP PROFILE program.

NOTE: ADCP PROFILE *does not generate discharge reports* from SonTek YDFF data.

CONNECTION OPTIONS

Two Methods:

- **Serial connections:** use a standard serial cable and, in HARDWARE, specify the port number. No need to specify baud, parity or stop bit; the driver automatically sets these.
- **Wireless Radio Modem:** This configuration uses two base stations: one for connecting the HydroSurveyor and a GPS antenna, and the other for RTK tides. Additionally, a USB antenna on your computer registers as a serial device (COM port). The GPS data comes through the base station, which then broadcasts the data back out in the driver.

In HARDWARE, setup your GPS as a UDP Server using the same port that you chose in the HydroSurveyor setup dialog. You can leave the Write Port blank.

SUBBOT.DLL

Version Number:17.1.6

Device Name: Sub-bottom Driver

DEVICE SETUP

Depth: Logs soundings or magnetometer data from this device.

This driver reports the bottom track depth to HYPACK® SURVEY for display and logging to the RAW and SEG/Y files.

Heading: Logs heading data from this device.

Only the Innomar device supports the Heading function. It will get the heading from the GPS and log it to the RAW file.

Tip:

If you are logging Heading in your GPS driver, this data will be redundant.

Heave: Logs heave, pitch and roll data from this device.

Only the Innomar supports this option.

Generate Output Messages: Generates messages or data outside of the Raw file.

This driver records a SEG Y file for each Raw file.

Use for matrix update: Color-codes a matrix based on the data received from this device.

Paper Annotation: Annotates each event on the sounder's paper roll. (See Driver Output.)

In this driver, this option facilitates event annotations in the sub-bottom device windows. Events are annotated in aqua with *Event Number* and *Time*.

DRIVER SETUP

FIGURE 1. Driver Setup



Choose your device from the drop-down list.

Analog Devices

Channel 2: For a dual channel analog device, Channel 2 enables the second analog channel. You must add a second instance of subbot.dll to your HARDWARE configuration.

This allows 2 channels of sub-bottom data to be acquired simultaneously, such as a pinger and a boomer. Currently, this mode will only passively listen for two trigger signals, it will not create them. Each channel has an independent display and logs to independent SEGY files: *LineName.seg* and *LineName_02.seg*.

Edgetech

Control Using Discover: Use the firmware to control the device.

DEVICE OUTPUT STRINGS

Binary data.

DRIVER OUTPUT STRINGS

DEVICE WINDOW

FIGURE 2. Sample Device Window

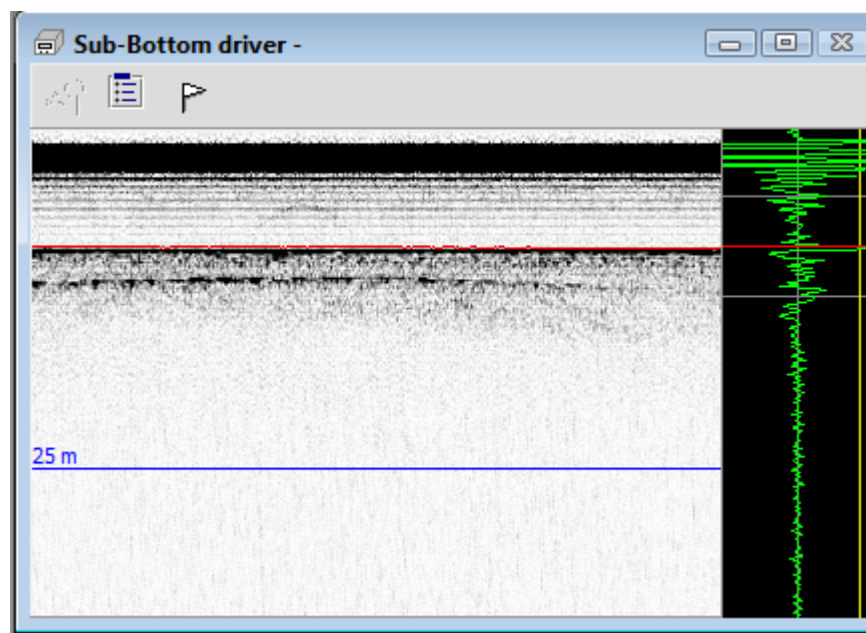

The SubBot device window shows the latest signal and a scrolling history.

Each panel display may also include a vertical grid at user-defined intervals, the bottom track as well as vertical target and event markers. Events are annotated in aqua with Event Number and

time. Targets are annotated in pink with the XY coordinates of the target.

The window may also include device-specific controls according to the sensor model you have selected.

To mark points of interest with targets, double-click on the scrolling portion of the display.

DISPLAY OPTIONS

To configure the device window display, click the Options icon.



FIGURE 3. *Configuring the Subbot Device Window*

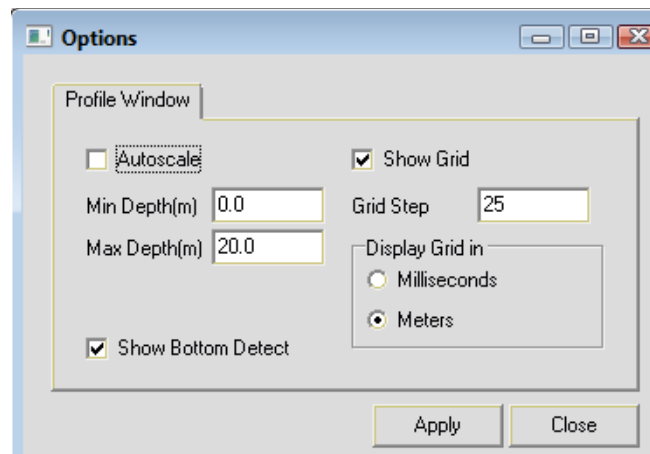

Autoscale: Sets the time range based on the current data.

To manually set the vertical scale, clear the **Autoscale** option and enter your desired **time or depth range** (according to the Display Grid in selection).

Show Grid: Toggles the display of horizontal lines at user-defined **Grid Step** intervals expressed in milliseconds or meters according to the **Display Grid in** setting.

Show Bottom Detect: Toggles the bottom detection line in the profile display.

ANALOG DEVICE SETTINGS

If you are using an analog device, the display includes an Analog Monitor window.

FIGURE 4. Analog Monitor Window

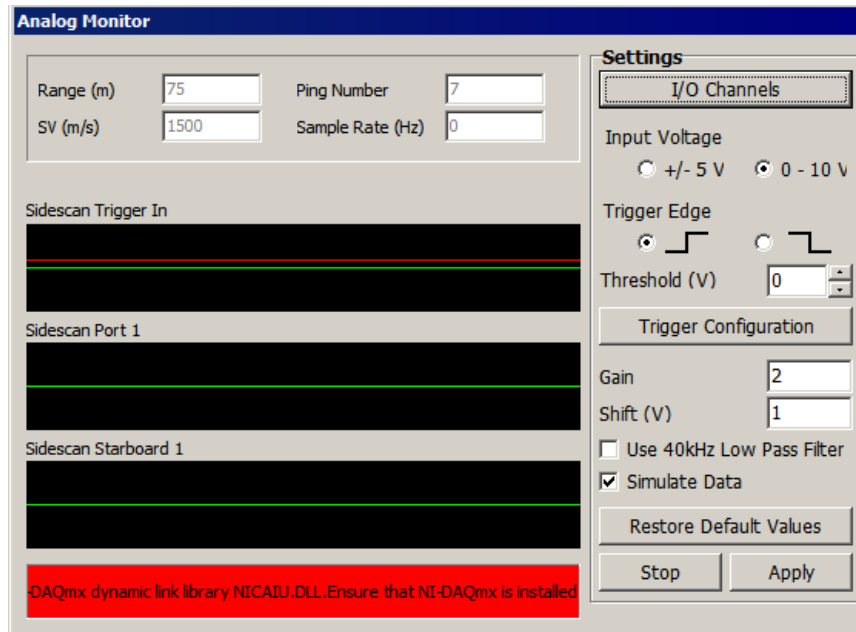

Input Voltage (Default = +/- 5V): Size of the trigger.

IMPORTANT: To provide optimal resolution, the A/D converter must be configured with a voltage range as close as possible to the device output peak without clipping your data. Use the Input/Output Configuration dialog for more powerful controls.

Trigger Edge (Low to high is the default): Low to High tells the driver to record data beginning at the start of the ping (when the voltage spikes). With a setting of High to Low, the driver logs data after the ping (when the voltage drops).

Threshold (V) (Default = 1): Minimum size recognized as a ping.

[Trigger Configuration] accesses the Trigger Configuration dialog:

FIGURE 5. Trigger Configuration Dialog

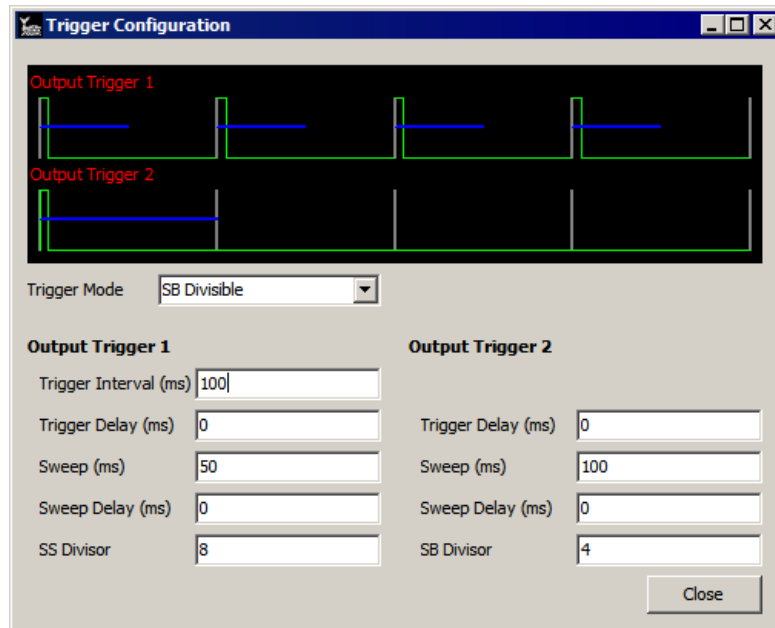

- **Trigger Mode** determines when the driver starts to listen.
 - **External:** The ping is generated outside HYPACK®. Set the Sweep and Sweep Delay.
 - **Internal:** Select this option when you log only sub-bottom data with this driver and HYPACK® generates the ping at time intervals defined by the Trigger Interval.
 - **SS Divisible:** Select this option when you log both side scan and sub-bottom data with this driver to manage conflicts between each type of ping. For each distance defined by the Side Scan Range, HYPACK® generates the evenly spaced sub-bottom pings according to the SS Divisor.
 - **SB Divisible:** Select this option when you log a second sub-bottom device. For each ping from Output Trigger 1, HYPACK® generates the number of evenly spaced sub-bottom pings according to the SB Divisor.

NOTE: Logging from 2 devices requires 2 instances of the subbot.dll. Configure the first using the Internal trigger mode and the second using SB Divisible Mode.

Additional options appear as they are applicable to the selected mode.

- **Trigger Interval (msec):** Time interval between Output Trigger 1 pings.
- **Sweep (msec):** Amount of time the driver logs data for each ping. Typically, less than the Trigger Interval.
- **Sweep Delay (msec):** How long after each ping before the driver logs data.
- **SS (side scan) Divisor:** Number of SS (side scan) Range Intervals for each sub-bottom ping. (Set the SS Range Interval in SURVEY.)
- **SB (sub-bottom) Divisor:** Number of pings from Output Trigger 1 for each ping from Output Trigger 2.

Gain (Default = 1. Recommended): Amplifies data.

Shift (V) (Default = 0): When there is no data, if the driver is registering slightly off the zero level, use this value to shift what the system is reading to zero. This is particularly important if you are getting both positive and negative data.

Use 40kHz Low Pass Filter (Default is "off".) Supported by high-end devices. This filter attempts to eliminate noise in the data.

Simulate Data (Default is "off".) For testing side scan only.

[Restore Default Values] resets the options to their default setting.

[Input/Output Channels] accesses the I/O Configuration dialog. Initially, this dialog defaults to our recommended settings.

- **If you are logging only Side Scan or Sub-bottom data**, clear the check box for the data type you are not logging to save power on the box.
- **Choose a channel and voltage range for each value applicable to your device.** Set the channel for all other values to 'None'.

FIGURE 6. I/O Configuration Dialog

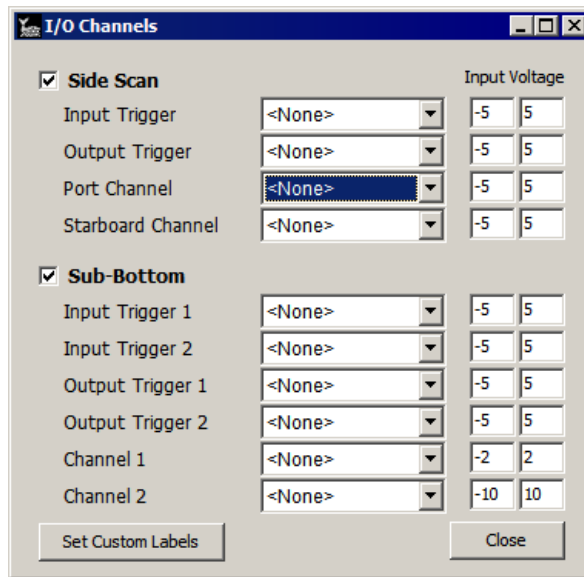

- **Input Triggers:** HYPACK® listens for a ping from an external source.
- **Output Triggers:** Trigger is generated by HYPACK®.
- **Port Channel** and **Starboard Channel:** Incoming side scan data.
- **Channel 1, Channel 2:** Incoming sub-bottom data.

NOTE: The Channel 1 and Channel 2 voltage values are synchronized with the [Base Gain](#) settings from the tool bar in either of the corresponding 'SB Channel 1' or 'SB Channel 2' device windows; changes in one cause the other to update.

- **[Custom Labels]** provides a dialog where you can rename your Input/Output options.

FIGURE 7. Custom Labels Dialog

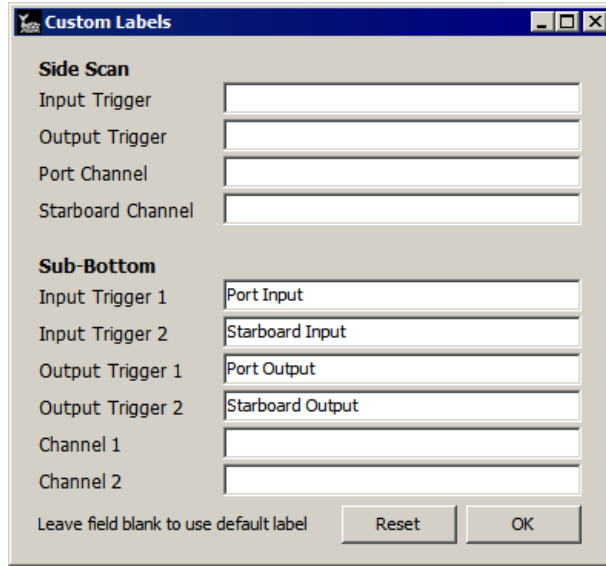

(See also [“Related Tech. Notes:”](#).)

FILTER AND GAIN CONTROLS

SURVEY also provides filter and gain controls *for display purposes only*.

Filter and Gain Controls provide flat gain, FFT band pass filtering and several color palette options. The dialog provides one tab for you to configure each channel individually.

IMPORTANT: These options should be set as accurately as you can for your data set. They directly affect the algorithms used to calculate your bottom track.

To access the controls, select VIEW-FILTER AND GAIN CONTROLS or click on the icon.



FIGURE 8. Filter and Gain Controls

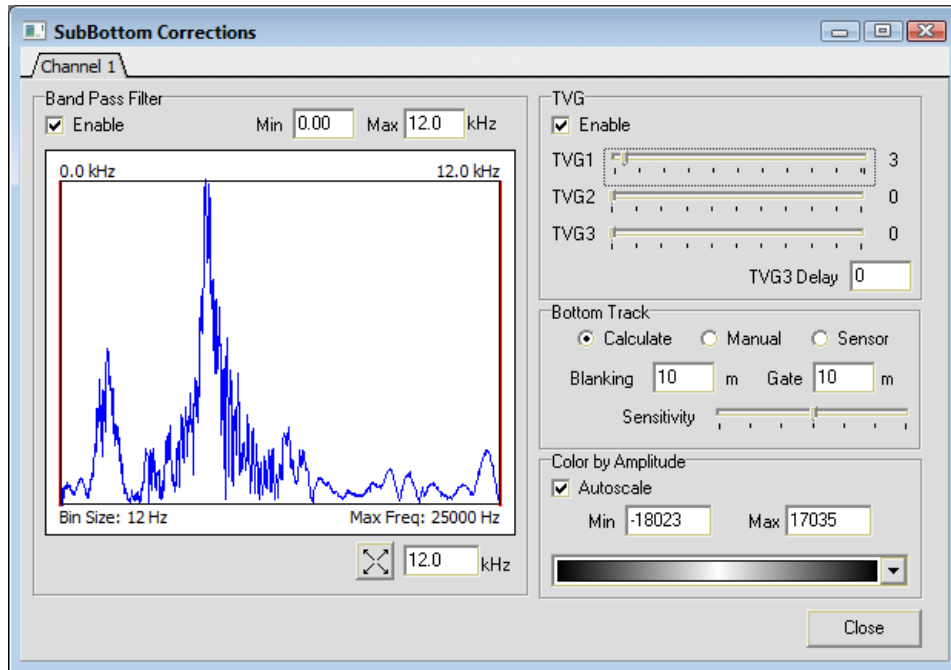

- **Band Pass Filter:** Defines the range of return data to be logged enabling you to avoid logging returns from the water column and from areas too far below the bottom.

Tip:

A typical range is from half the system frequency to double the system frequency.

- **TVG:** (Unavailable for Edgetech devices.) Three Time Varied Gain (TVG) windows can be specified to improve the displayed imagery. In each, the amount of gain applied to the signal increases with time and is in dB units over 1 second. For example, when TVG1 is set to 20, the TVG curve is configured so the sample 500 milliseconds down the signal trace will be amplified 10dBs, 1 second down by 20dBs, and so on.
 - **TVG1** begins at the start of the signal. Don't overdo this one as it will amplify the bang pulse and water column noise in addition to everything else. Sliding TVG1 all the way to the left will set it to 'B' (for blanking).
Blanking Mode hides water column data on the display.
 - The **TVG2** window begins at the bottom detect. It is the most useful since you can increase the gain of the imagery of the sediments without affecting the water column noise. Of course, for TVG2 to work correctly it is important that the bottom tracking be accurate.
 - **TVG3:** Finally, for deep surveys you can set a third TVG curve to begin at a specified time: the **TVG3 Delay** in milliseconds.

- **Color by Amplitude** option allows you to choose unipolar (negative amplitude is zeroed), bipolar (negative amplitude in red, positive in blue), or rectified (absolute value amplitude) viewing. Use the **Min.** and **Max.** settings to set the range of the palette or check the **Autoscale** option to let the program automatically scale the display to the data for you.
- **Bottom Track:**
 - **Calculate:** Detects the bottom from the observed signal. Specify Blanking, Gate and Sensitivity (all in msec).
 - **Blanking:** Anything before the specified time will be ignored. Set blanking to ignore, at least, the bang pulse.
 - **Gate and Sensitivity:** As data comes in, the gate follows along the detected depth and the algorithm looks within it for the observed signal to break the yellow Sensitivity level. When this occurs the driver logs the bottom depth, the gate shifts to center on that depth and the process begins again with the next ping. The gate values appear in gray in the voltage trace display during data collection, but not in post processing.

Tip:

Deeper water surveys require smaller Gate and lower Sensitivity for the program to accurately find the bottom.

- **Manual:** Sets the depth to a user-defined level.
To define the level, click in the echogram display at the required depth.
- **Sensor (Default):** The driver accepts the depth as reported by the profiler.

NI DEVICE:

Trigger spikes.

KNOWN SUPPORTED DEVICES:

- Analog Sub-bottom
- Older Benthos systems
- EdgeTech 2000 and 3000 Series
- Innomar SES 2000
- Klein K Chirp 3310
- Knudsen Pinger and Chirp
- SDI
- SyQwest B2010/SB3510HD
- SyQwest Stratabox
- Teledyne Chirp

SPECIAL NOTES

Data collected with the subbot.dll can be loaded to the SUB-BOTTOM PROCESSOR. There you can mark targets and digitize your layers.

When you mark targets in the SUB-BOTTOM PROCESSOR they are saved to the Sub-bottom target group and named using the date and time derived from its position in your data.

Each digitized layer is saved to an All format file, which can then be displayed and plotted in CROSS SECTIONS AND VOLUMES.

KNOWN SUPPORTED DEVICES

- Analog (NI USB)
- Benthos
- Edgetech 3000 Series
- Falmouth HMX-6XX
- GeoAcoustics GeoChirp
- Innomar SES 2000
- Knudsen Pinger and Chirp
- Older Benthos SBP systems
- Specialty Devices Inc.
- SyQwest B2010/SB3510HD
- SyQwest Stratabox
- Teledyne Odom Chirp

SUPPORT FOR MULTIPLE INSTANCES

- Recognizes systems with multiple subbot drivers and stores separate sets of configuration settings to the INI file.
- Playback supports systems with multiple instances of subbot.dll.

SEG-Y PLAYBACK

When you connect the subbot.dll to a SEG-Y file, the device window provides playback controls with which you replay the selected SEG-Y file.

FIGURE 9. Playback Controls

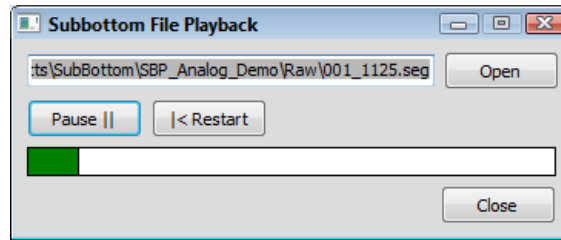

RELATED TECH. NOTES:

- *Advanced Analog Triggering* (<http://bit.ly/1RvI5Qd>)
- *Using the Analog USB Device in HYPACK® for Sub-Bottom or Side Scan* (<http://bit.ly/1UW8I4n>)
- *HYPACK® 2015 Tips for Analog Sub-Bottom Profilers* (<http://bit.ly/1eugYBH>)

SYQWEST.DLL

Version Number: 13.0.0.4

Device Name: Syqwest Hydrobox

DEVICE SETUP

Depth: Logs soundings or magnetometer data from this device.

Use for matrix update: Color-codes a matrix based on the data received from this device.

Paper Annotation: Annotates each event on the sounder's paper roll. (See Driver Output.)

DRIVER SETUP

None.

DEVICE OUTPUT STRINGS

EDT L 10.0 FT EDT H 10.0 FT

"H" and "L" denote High and Low Frequency respectively.

DRIVER OUTPUT STRINGS

Annotation Strings:

Start line annotation: *EventNumber 'S' LineFileName Time Depth*

End / pause annotation: *"EventNumber EorM Time Depth*

EorM means it writes E if its the end of line and M for a pause.

DEVICE WINDOW:

Scrolling graph of depth data from both frequencies, if present.
Status bar displays device output strings.

Motion Sensors

•

Motion sensors detect **heave** (vertical displacement), **pitch** (rotation about an axis that runs from port to starboard through the ship's center of mass) and **roll** (rotation about an axis that runs from stern to bow through the ship's center of mass).

The MRU should be placed as close as possible to the vessel's center of gravity.

The heave-pitch-roll data is saved in the Raw data files as HCP Records. These records contain the Device Number, Time Tag, Heave, Pitch, Roll and Status Flag. The HCP records are used when processing data in the SINGLE BEAM EDITOR for single and dual frequency data or the 32-bit HYSWEEP® EDITOR program for multiple transducer and multibeam data. Each program takes the exact time of the depth measurement and then interpolates heave-pitch-roll information for the exact time that the depth was measured.

FIGURE 1. *Heading-Pitch-Roll Data in the 32-bit HYSWEEP® EDITOR for Multibeam and Multiple Transducer Systems*

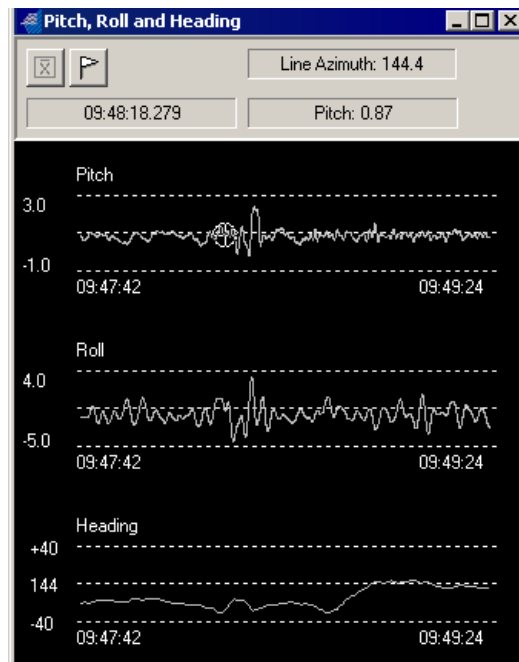
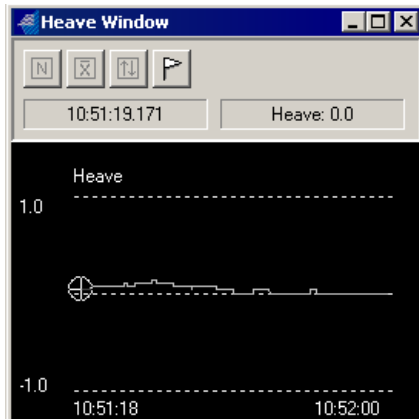

FIGURE 2. Heave Data in the 32-bit HYSWEEP® EDITOR



In the SINGLE BEAM EDITOR, it is possible to tell the program whether or not to apply heave, pitch and roll settings. The position of the echosounder beam can also be calculated, using the pitch and roll information. This is implemented by checking the Steer Sounding Beam box in the Advanced Read Parameters in the editor program.

Tip:

Some devices can be set to output data for its position at the pivot point of the boat or for the calculated position of the echosounder. In HYPACK®, always output data for the MRU position and let your HYPACK® programs do the necessary calculations.

FIGURE 3. Specifying corrections for Motion Reference Units

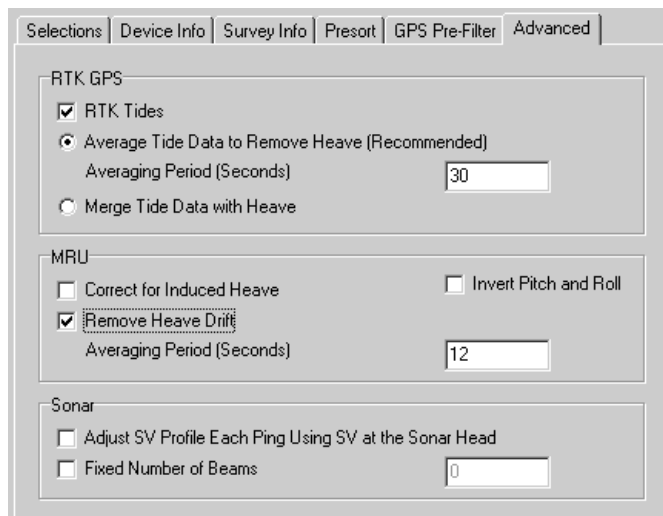

GENHPR.DLL

Version Number: 14.0.1

Device Name: Generic Heave Pitch and Roll

DEVICE SETUP

Heave: Logs heave, pitch and roll data from this device.

DRIVER SETUP

FIGURE 1. Driver Setup



Position determines the character position in the device output string for each value.

Length is the number of characters in each value.

Multiplier multiplies the value by this number. This is handy to properly place a decimal point in the output value.

End of Line tells the driver if the line ends with Carriage Return or Carriage Return, Line Feed.

Message Header: If your device outputs multiple strings, you can enter a string to distinguish which string should be read.

DEVICE OUTPUT STRINGS

Any device outputting ASCII HPR data.

DRIVER OUTPUT STRINGS

DEVICE WINDOW:

Writes original string.

Formats each value parsed to 2 dec. and writes:

```
"Heave=Heave  
Pitch=Pitch  
Roll=Roll"
```

HHPR.DLL

Version Number: 14.0.1

Device Name: Honeywell HP

DEVICE SETUP

Heading: Logs heading data from this device.

Heave: Logs pitch and roll data from this device.

Record device specific messages: Logs additional data related to the device to the Raw file. Each record will be identified by a driver-specific, 3-character tag.

Saves the original device output string preceded by the "HON" tag.

DRIVER SETUP

None.

DEVICE OUTPUT STRINGS

`$PTNTHPR,Heading,h,Pitch,p,Roll,r"`

where:

'h', 'p' and 'r' are single characters indicating data error for the preceding value.

Heading is expressed in radians.

If 'h', 'p' or 'r' is anything but 'N', SURVEY displays an alarm.

DRIVER OUTPUT STRINGS

DEVICE WINDOW:

Original Line

Converts heading to degrees, formats heading, pitch and roll to 2 decimals and writes:

```
"Hdg=Heading, Pitch=Pitch, Roll=Roll",  
("Hdg=%.21f, Pitch=%.21f, Roll=%.21f")
```

SPECIAL NOTES

Alarms:

If h, p or r is anything but 'N', Survey displays an alarm.

String char not 'N'	Alarm Displayed
h	"Hdg"
p	"Pitch"
r	"Roll"

OCTANS.DLL

Version Number: 15.0.1.4

Device Name: IXSEA Octans

DEVICE SETUP

Heading: Logs heading data from this device.

Heave: Logs pitch and roll data from this device.

DRIVER SETUP

None.

DEVICE OUTPUT STRINGS

\$PHTRO,3.20,P,2.22,T*56
\$HEHDT,24.08,T*21

DRIVER OUTPUT STRINGS

DEVICE WINDOW:

Formats parsed values to 2 decimal places and writes:

"Heading=*Heading*

Roll=*Roll* Pitch=*Pitch*"

NOTE: May write Heading or Pitch/Roll information, according to your function selections.

TSS320.DLL

This driver supports the TSS320 Motion Sensor. The device has two modes—MRU only and MRU/Echosounder combination mode.

VERSION NUMBER

14.0.1.5

DEVICE NAME

TSS Motion Reference Unit

DEVICE SETUP

Depth: Logs soundings or magnetometer data from this device.

Heave: Logs heave, pitch and roll data from this device.

NOTE: NOTE: This option is applicable only if you have selected the Depth option.

Record device specific messages: Logs additional data related to the device to the Raw file. Each record will be identified by a driver-specific, 3-character tag.

DRIVER SETUP

FIGURE 1. Driver Setup Dialog

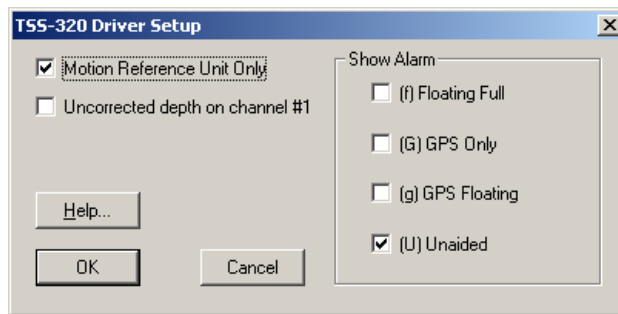

MRU Only means that you do not have the MRU connected through an echosounder. In this case, your Device Setup should have Heave Compensator checked and Echosounder and Annotation unchecked.

Uncorrected Depth On Channel One refers to the echosounder.

Show Alarms: Survey shows a “HEAVE” alarm if the user-defined status is not met. The options are listed in order from most to least restrictive:

- **Floating full:** GPS input, vessel going >2 knots and TSS getting VTG and HDT. Shows "F" in device window.
- **GPS only:** GPS input (VTG) but vessel going >2 knots so GPS. Shows "G" in device window.
- **GPS floating:** GPS input (VTG) but vessel going <2 knots so GPS. Shows "g" in device window.

NOTE: Testing by the dock, you'll likely get “g”, but once you start moving, it should change to “G”.

- **Unaided (U):** No GPS input. Shows "U" in device window

DEVICE OUTPUT STRINGS

If *MRU only* is not selected:

- The string must be at least 39 chars..
- Dep1 is read from char 16-21.
- Dep2 is read from char. 9-14.
- Heave is read from char 23.
- Roll is read from char 30.
- Pitch is read from char 36.

If *MRU only* is selected:

- The string must be at least 24 chars.
- Roll is read from char 15.
- Pitch is read from char. 21.
- Heave is read from char 9.

DRIVER OUTPUT STRINGS

The heave-pitch-roll data is saved in the Raw data files as **HCP Records**. These records contain the Device Number, Time Tag, Heave, Pitch, Roll and Status Flag.

DEVICE WINDOW:

Lists the following values:

- Heave
- Quality: This value is viewed only in real-time. It is not logged.
- Pitch
- Roll
- Error

SERIAL PORT:

On Event, sends DTR then "F" out serial port.

When Heave() is called:

If there's a heave error, it writes:

```
"Heave=????? Roll=roll Pitch=pitch",  
("Heave=????? Roll=%5.2f Pitch=%5.2f")
```

otherwise it writes:

```
"Heave=heave Roll=roll Pitch=pitch"  
("Heave=%5.2f Roll=%5.2f Pitch=%5.2f")
```

SPECIAL NOTES

Event Pulse sends both a character for old style event mark generators and a pulse over the DTR line (preferred method).

Also supports **MRU6** which you can set to output a TSS1 string.

Heading Devices

•

HYPACK® has the following options to determine the vessel orientation:

- Use the course made good of the GPS antenna.
- Use the course made good as calculated by the HYPACK® SURVEY program.
- Use a fluxgate compass.
- Use a survey quality gyro.
- Use a GPS system that uses an antenna array to provide orientation.
- Use two GPS systems with separated antennas to calculate the orientation.

Course Made Good: Almost any GPS device will calculate the course made good of the GPS antenna. If your GPS outputs a VTG message, you have access to the course made good. You can click on Heading in the Type box, and then the program will use the GPS course made good to orient the vessel.

Fluxgate Compasses provide accurate orientation information for most small survey launches. Care should be taken to determine whether the compass is outputting the magnetic heading or the true heading (magnetic plus deviation).

Survey Quality Gyros, such as the SR20, SR40, Robertson and Scandinavian Microsystems can be integrated using a device-specific driver or by using the GenGyro device driver.

GPS with Antenna Array: Certain GPS devices determine the vessel orientation (heading, pitch and roll) from an array of fixed GPS antennas. These devices provide both position and heading information.

Two GPS Systems: A special 'OTFGyro' (On-the-fly Gyro) option, is available in the GPS driver to determine the vessel orientation by using two GPS systems. By knowing the exact offset between these two devices, the driver compares the reported positions and computes the heading of the vessel. The most accurate calculations are attained from the most accurate GPS output and exact measurements of the separation between the two antennas.

BEWARE!

Without any 'Heading' device, the SURVEY or DREDGEPACK® program will default to using the calculated Course Made Good for the vessel orientation. If your transducer is located directly beneath your GPS antenna, this doesn't really matter and is only a matter of aesthetics. *If you have a significant separation between your GPS antenna and transducer, the presence of crosscurrents could provide error between the course made good and the actual vessel orientation.* The best solution is to make sure your transducer is mounted directly below your GPS antenna.

•

BEWARE!

Care should be taken not to have two heading devices. For example, some users absentmindedly check the Heading function in the GPS Device Setup dialog when they already have a gyro configured. The heading will update every time the gyro and GPS update. This can cause the boat to “Twitch” between the two different heading values.

ADGC.DLL

Version Number: 6.2.1.2

Device Name: KVH Digital Compass

DEVICE SETUP

Heading: Logs heading data from this device.

Heave: Logs pitch and roll data from this device.

DRIVER SETUP

None.

DEVICE OUTPUT STRINGS

%pitch,roll,heading<LF>, where each value is multiplied by 10.

DRIVER OUTPUT STRINGS

DEVICE WINDOW:

Writes original line.

If heading is found, it's formatted to 1 decimal and written:

```
"Heading=heading"  
("Heading=%.1f").
```

Formats pitch and roll to 1 decimal and writes:

```
"Pitch=pitch, Roll=roll"  
("Pitch=%.1f, Roll=%.1f").
```

SPECIAL NOTES

Sets eol to <LF>.

SGBROWN.DLL

Version Number: 14.0.1.2

Device Name: SGBrown Gyro

DEVICE SETUP

Heading: Logs heading data from this device.

DRIVER SETUP

None.

DEVICE OUTPUT STRINGS

Format	DegS<cr><lf>	
	Deg	Degrees
	S	1/6 degrees
Sample String		

DRIVER OUTPUT STRINGS

DEVICE WINDOW

If driver doesn't get a line, writes:

"Comm Error: Status = *Status*"

Formats heading to 2 decimals and writes:

"hdg=*Heading*"

("hdg=%5.2f")

SPECIAL NOTES

EOL is <LF>.

Tide Gauges

•

Telemetry tide gauge device drivers either interrogate the tide equipment at your specified intervals or simply record the values when the devices decide to send an update. The receiver records the data and may also broadcast the serial string through a radio connection to the survey computer.

The SURVEY or DREDGEPACK® program writes the initial tide correction in the header of each data file. Any time a new tide reading arrives, it is time tagged and written to the RAW data file as a TID record. TID records are decoded in the SINGLE BEAM EDITOR (for single and dual frequency data) or the 32-bit HYSWEEP® EDITOR (for multiple transducer and multibeam systems). A tide correction is determined for each sounding, based on the last available tide reading.

If you have multiple tide stations in the area, the tide value logged depends on the capabilities and settings in the tide device driver. Alternatively, in post-processing, you can use the MANUAL TIDES program to generate tide corrections files (*.TID) for each station, then use the Tide Adjustments feature in the editor program to interpolate the correction value based on the boat position relative to the tide stations.

HTG5000.DLL

Version Number: 14.0.2.1

Device Name: Hazen HTG-5000 Tide Gauge

DEVICE SETUP

Tide: Logs tide data from this device.

(Required)

DRIVER SETUP

None

DEVICE OUTPUT STRINGS

Line at least 15 chars.

Time: 5th – 8th char

Tide: 9th – 14th char. output in US feet.

Gauge ID: 15th char.

DRIVER OUTPUT STRINGS

DEVICE WINDOW

```
"Time: Time Tide corr: Tide"  
("Time: %4.4i Tide corr: %-6.2f")
```

NOTE: The tide value written here is positive, but the driver saves a negative value to raw data to conform with the HYPACK® methodology.

If device times out (no message in 5 msec.), writes "Polling Device" to signify it has sent the "R" to device again.

SERIAL PORT

Sends "R" after it reads each line and if no string comes from device for more than 5 msec.

TIDEDR.DLL

Version Number: 16.1.0.0

Device Name: Tide Gauge Driver

Supports several tide gauges, can be configured to read an ASCII text string or a HYPACK® Tide Correction file (*.TID), and allows you to change to manually entering the tide correction in HYPACK® SURVEY.

DEVICE SETUP

Tide: Logs tide data from this device.

DRIVER SETUP

Tide Source Tab:

FIGURE 1. Driver Setup -- Tide Source (left)

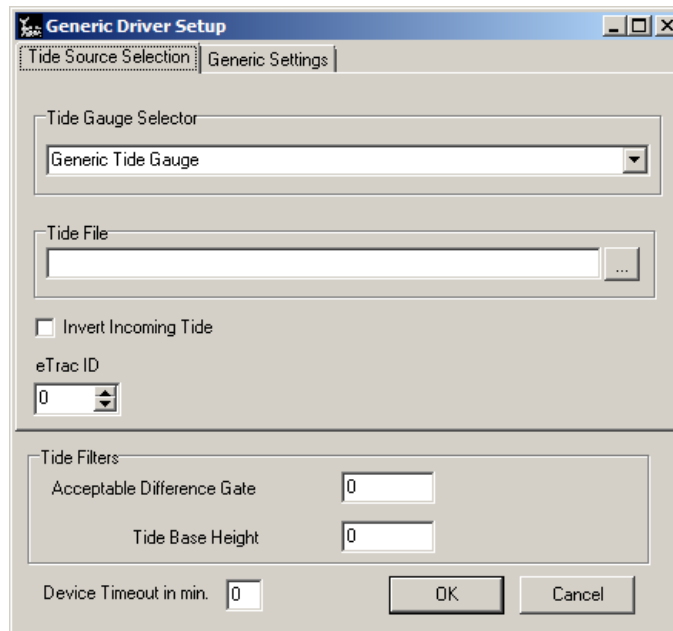

Tide Gauge Selector: Select the tide device you are using.

Tide File: Sets the TID file (single or multi-day TID) from which SURVEY will read tide data when Prediction File is selected in the Device window in .

Invert Incoming Tide: Reverses the sign for the tide correction value.

eTrac ID: Enter tide station ID for the station from which you want the driver to read data. Enter 0 to use data from all stations.

Tide Filters:

- **Acceptable Difference Gate:** Maximum difference from the last tide reading that will be accepted. A value of 0 disables the function.
- **Tide Base Height:** Added to the tide reading when you are working at elevations.
- **Device time-out (minutes)**

FIGURE 2. Driver Setup -- Tide Source (left), Generic Setup (right)

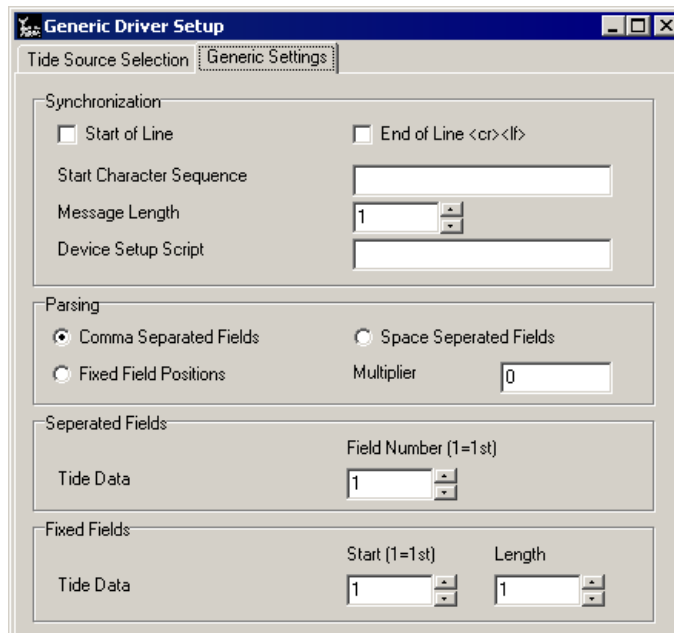

Start of Line should be checked if your device output string begins with a set character sequence. Define the sequence under Start Character Sequence.

End of Line check to indicate the end of the output string is carriage return, line feed. In this case, there's no need to define a message length.

Message Length is for those devices that do not end each record with carriage return, line feed. It tells the program how many characters are in 1 complete record.

Device Setup Script an initialization string that HYPACK® will send to the device when SURVEY is launched.

Parsing options describe the format in which the data is included in the string. Data values may be separated using commas or spaces, or they may occupy a constant position within the string.

Separated Field Options: If you have selected either comma or space separated fields in the Parsing options, define which field contains the tide information here.

Fixed Fields: If you have selected the Fixed Field Positions parsing option, define which character begins the tide data value and how many characters it includes.

DEVICE OUTPUT STRINGS

If Generic setup, none. This driver is designed to accommodate any ASCII string format.

TABLE 1. Supported Gauges and their Expected Output Strings

Device Selected	Output Stiiing
3011R Tide Gauge	Tide begins at the 6th character and is 6 characters long.
Aandera Auto TG	Tide begins at the 6th character and is 6 characters long. xxxxxxxTTTTTTxxxxxxx
Etrac Tide Gauge	time , date, tide, volt, checksum %11:47:39,07-18-2005,+07.45,14.06V,00001&
Ceetide	tide date time checksum -2.51 10-10-08 10:47:30 *3C
General Acoustics Tide Gauge	GATIDE_GAUGE L=%f

DRIVER OUTPUT STRINGS

DEVICE WINDOW:

The Device window graphs your tide source and recorded tide corrections over time. It also includes options that can be selected/changed at any time.

Tide Source:

- **Telemetry Gauge** reads from a tide gauge.
- **[Lock]** locks gate width to filter out spikes.
- **Prediction File** reads tides from the predicted tide file (single or multi-day TID) listed in the Driver Setup.
- **Manual Entry** allows you to manually set the tide value during Survey.

- **Show Prediction vs Reading:** Calculates and displays the difference between the tides from the tide file specified in the driver setup, and from the tide gauge.
- **Offset** allows you to offset the tide value recorded from the gauge at any time.

FIGURE 3. Sample Device Window

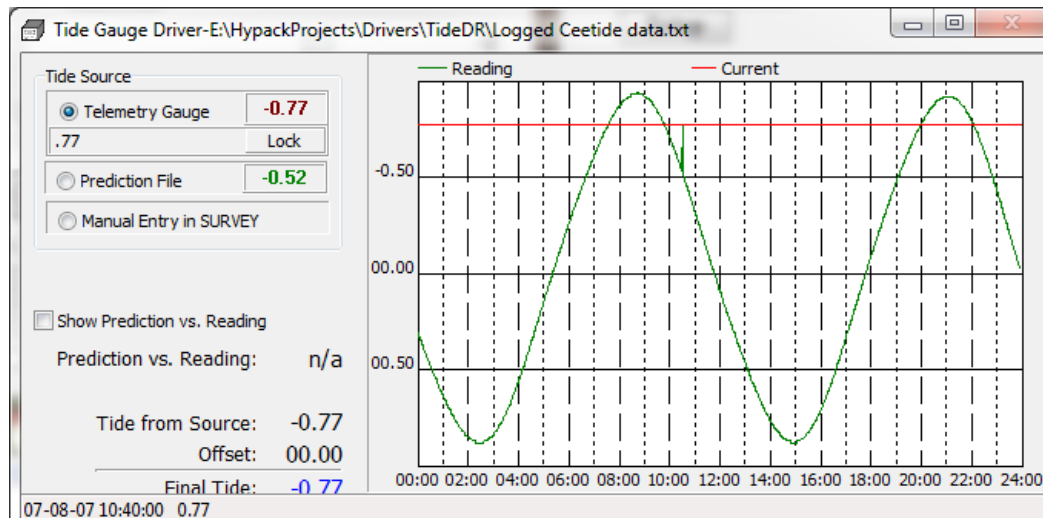

SERIAL PORT:

When SURVEY begins, the driver sends the user-defined Start Character Sequence.

DREDGEPACK®

Drivers

•

Dredge configurations vary widely depending on the type of dredge and the devices in use.

Dredge cutting tools are configured in the same manner as additional mobiles. For each cutting tool, add a mobile and assign to it the driver required to report its position to DREDGEPACK®. Precise measurements of offsets and arm or ladder lengths are essential to assure accurate positioning of your mobiles including your cutting tool.

CUTTER SUCTION DREDGE CONFIGURATIONS

Cutter suction configurations must generate data for the dredge position and heading, and for the cutter head position and depth.

FIGURE 1. Cutter Suction Dredge Diagram

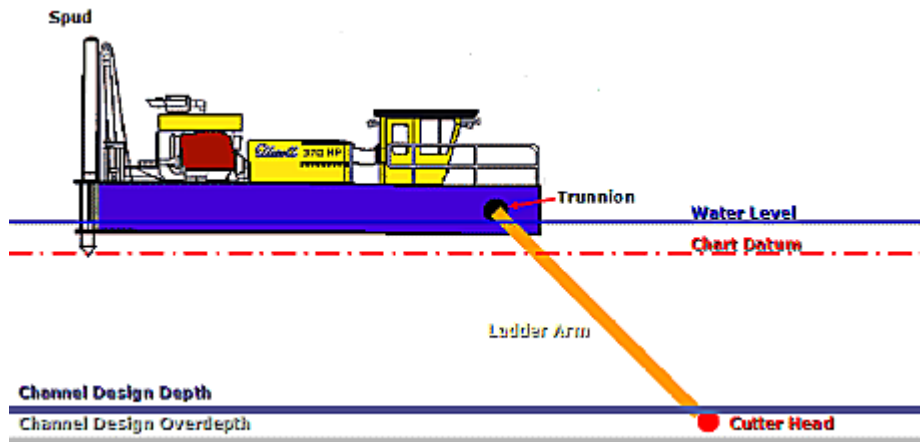

TABLE 1. Sample Cutter Suction Dredge Driver List

Data	Driver	Assigned to...
Dredge Position	GPS.dll	Boat
Dredge Orientation	Gyro or GPS	Boat
Cutter Head Position and Depth	Inclinometer.dll - several brands are built into the driver. Also includes manual configuration. OR Bubblers.dll (or other bubbler driver) for bubbler systems.	Arm
Cutter Display Graphics (Optional)	Cutter.dll	Arm
Spud Position	LRInd.dll	Spud

The HYPACK® Driver Interfacing Guides, located in your \HYPACK 2018\Help folder, includes detailed configuration information.

The Dredge:

The dredge position is the same as a simple survey boat with one exception: the dredge origin will be the trunnion position at the height of the static water line.

An 'Orientation GPS' system can provide both position and heading without the need of a gyro.

NOTE: Fluxgate compasses do not work well on dredges.

The Cutting Tool:

The cutting tool is configured as a separate mobile. The inclinometer driver uses a ladder length from the setup and the angle it measures to calculate the depth and position of the cutter head.

FIGURE 2. *Inclinometer.dll Driver Setup Dialog*

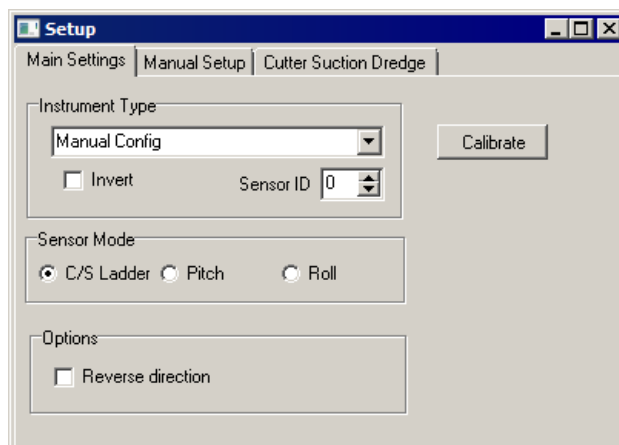

A short calibration routine assures accurate returns. While the setup dialog is open, set the cutter head on the waterline and click [Calibrate]. The driver calculates its depths using that height as 0.

Swing-ladder dredges also require the HD25A.dll assigned to the cutter head to measure horizontal motion of the arm.

Optional Settings

The **Ladder Arm** may also be configured as a separate mobile. Assign the cutter driver to this mobile to support more realistic graphics in its device window. Sample shape files for those required by this driver are included in the \HYPACK 2018\BoatShapes\Shapes for the Cutter folder. The driver will automatically adjust the scale to convert the dimensions in the shape file to the real-world sizes specified in this dialog. The results are seen in the Cutter Device window. This driver should be assigned to the arm that is designated as the main vessel.

FIGURE 3. Sample Cutter.dll Driver Setup

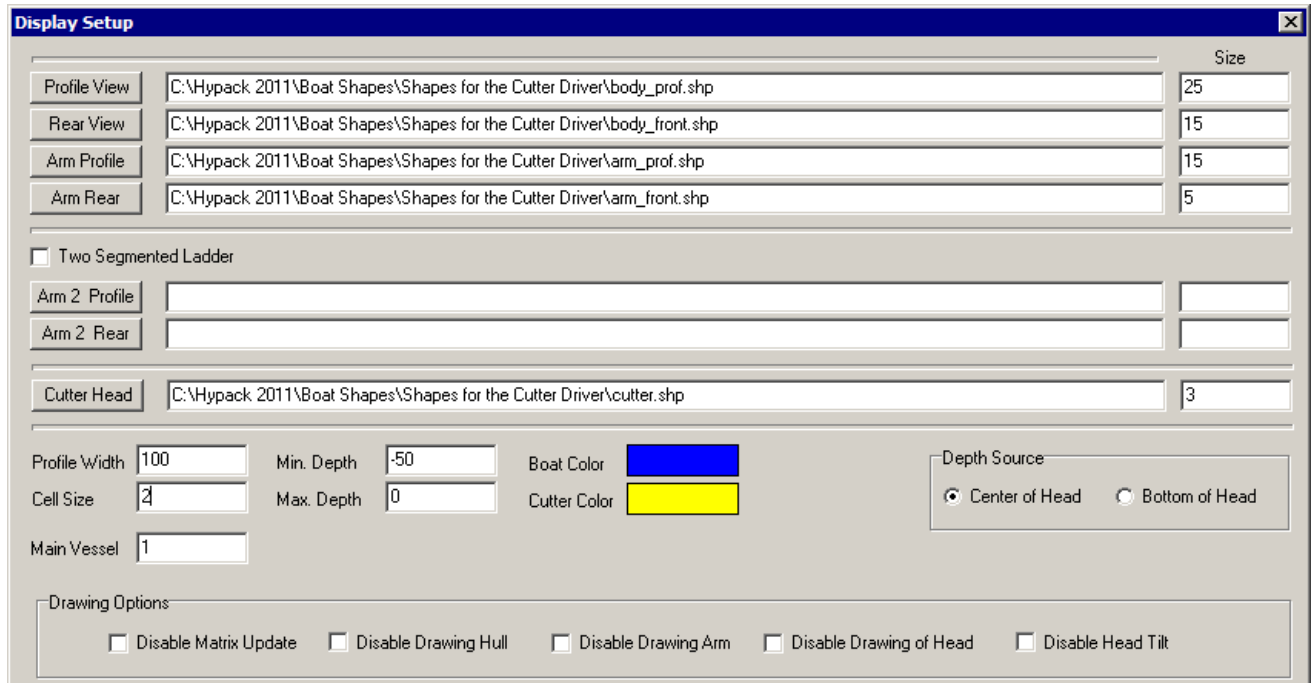
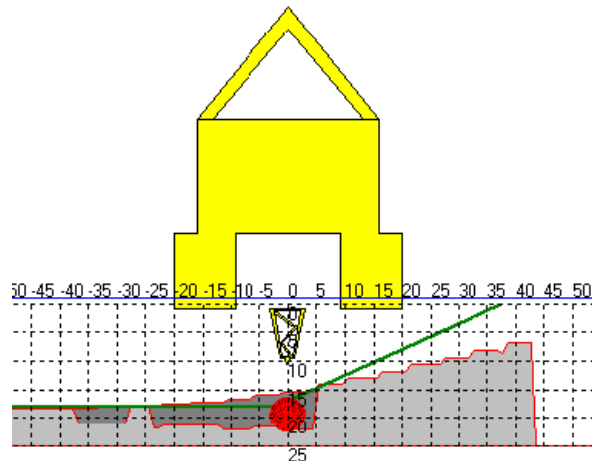

FIGURE 4. Sample Cutter Driver Device Window



The **Spud Position** can be configured as an additional mobile. This would be only for the sake of realism in 3DTV; it has no bearing on data collection. The position would be calculated using the GenOffset or Sim_rel driver.

HOPPER DREDGE CONFIGURATION

Hopper dredge configurations must generate data for:

- The dredge position and heading,
- The cutter head position and depth.

Your configuration should also include draft sensors to measure the significant change in draft as the load on your dredge increases.

FIGURE 5. *Hopper Dredge Diagram*

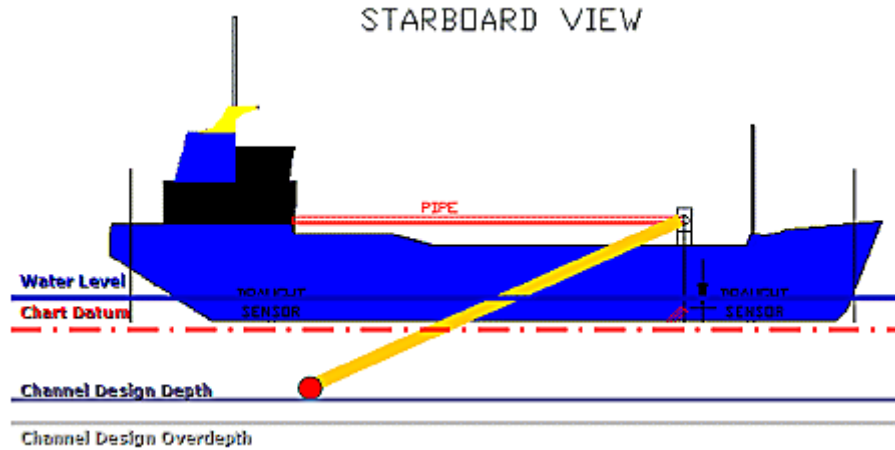

TABLE 2. *Sample Hopper Dredge Driver List.*

Data	Driver	Assigned to...
Dredge Position	GPS.dll (either DGPS or RTK)	Boat
Dredge Orientation	Any Heading system	Boat
Draft	Bubbler.dll (Pressure Transducers)	Boat
Hopper Position and Depth	Pressure Sensor or Bubbler—OPC Network	Arm
Hopper Display Graphics (Optional)	Hopper.dll	Boat

The HYPACK® Driver Interfacing Guides, located in your \HYPACK 2018\Help folder, includes detailed configuration information.

The Hopper driver, combined with boat shape files (*.SHP) representing the profile and rear views of the dredge and the cutter head, create detailed displays in the Hopper driver device window. When dredges have more than one hopper arm, each is represented by a mobile with its own hopper driver assigned to it. The Forward and Starboard Offsets indicate the relative position of the pinion points from the boat origin.

Most hopper dredges report their information via various OPC configurations. This requires a custom driver for each hopper dredge. Contact HYPACK Technical Support for assistance.

FIGURE 6. Hopper Dredge Diagram

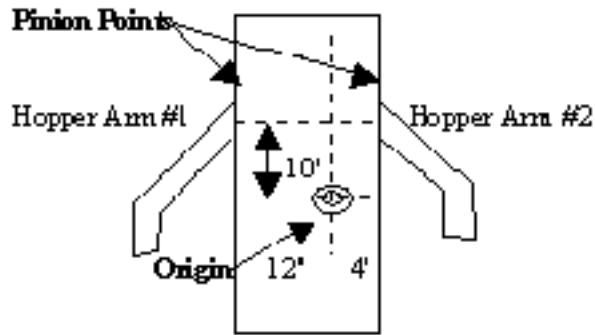

Devices	Offset Dialogs
Hopper Arm #1	X-Offset = -12 Y-Offset = -10
Hopper Arm #2	X-Offset = 4 Y-Offset = -10

FIGURE 7. Hopper Driver Setup

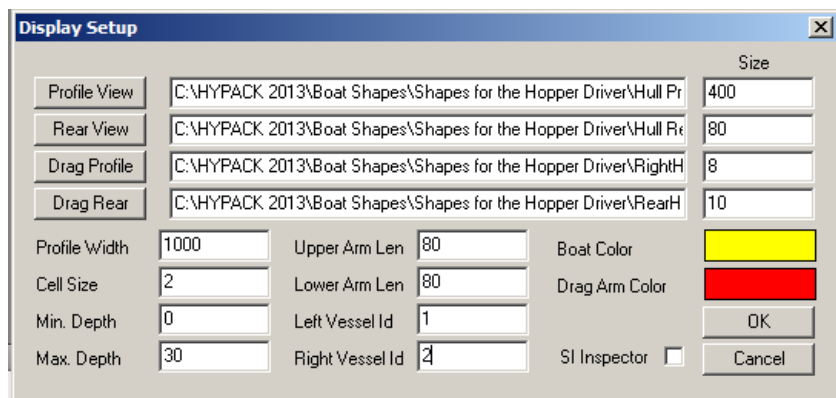
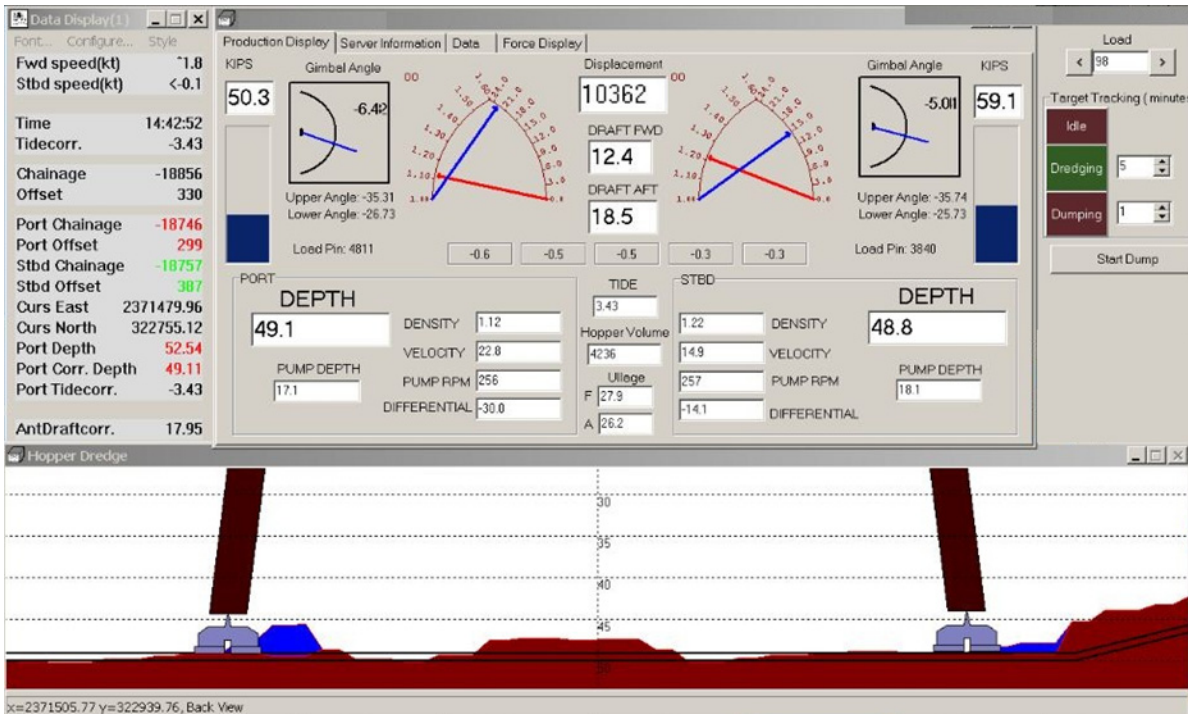

FIGURE 8. Sample Hopper Display



EXCAVATOR DREDGE CONFIGURATIONS

Excavator configurations must generate position and heading data for the excavator cab, and an include an inclinometer for each joint in the arm—cab to boom, boom to stick, stick to bucket. The barge position is optional.

TABLE 3. Sample Excavator Driver List.

Data	Driver	Assigned to...
Cab Position	GPS.dll (either DGPS or RTK)	Boat
Cab Orientation	Any Heading system	Boat
Bucket Position and Depth	Excavator.dll	Excavator
Barge Position (Optional)	GPS.dll using OTFGyro option	Barge
Tide	If GPS is not RTK.	Boat

The HYPACK® Driver Interfacing Guides, located in your \HYPACK 2018\Help folder, includes detailed configuration information.

The **Excavator** driver reads values for the angles and distances, and calculates the correct positions for the arm and bucket. This

driver supports multiple angle sensors. Select your sensor type at the top of the dialog.

FIGURE 9. Excavator Driver Setup

Excavator Type: US Digital T-7
 Use SEI Interface

Measurements

Boom Length	Stick Length	Stick 2	Bucket Length
10	10	5	5

Body Length ** 10

Sensor ID Assignment

Boom Sensor	Stick Sensor	Stick2 Sensor	Bucket Sensor
0	0	0	0

Sensor Override Values

<input type="checkbox"/> Boom	<input type="checkbox"/> Stick	<input type="checkbox"/> Bucket
0	0.0	0

BKT Matrix Angles

0	0
---	---

Set to 0.0 to disable

Auto Bucket Down Depth Increment

0

Set to 0.0 to disable

The driver then does the required calculations, stores the data to shared memory and provides a real-time graphical display of your excavator relative to your matrix and channel depths.

FIGURE 10. Sample Excavator Device Window

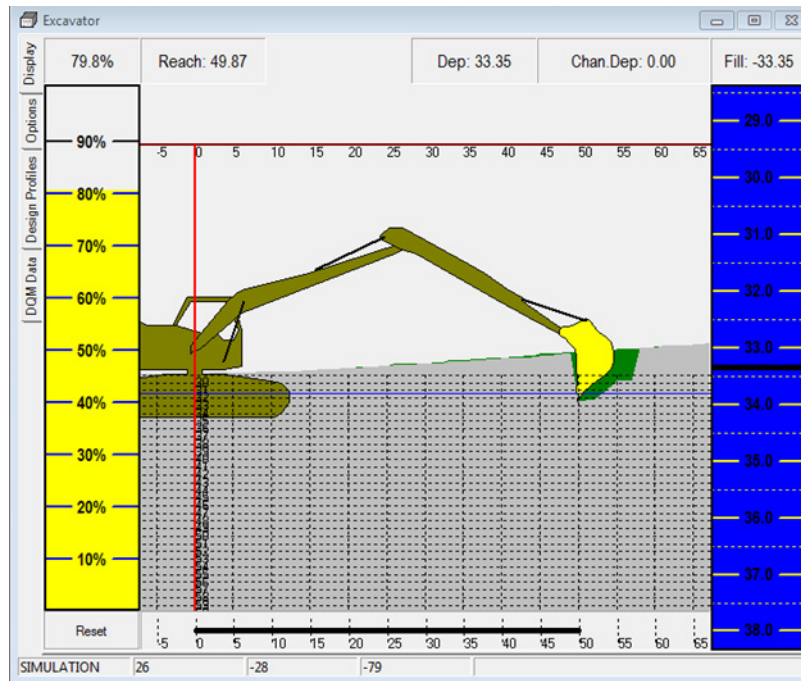

The barge position is for display purposes only. Using the OTFGyro option in the GPS driver, you can position the barge in your area map.

BUCKET DREDGE CONFIGURATIONS

Bucket dredges may be configured in either of two ways:

- **Get the Position and Heading of the cab then calculate the position of the boom** using cable length from the LCI90 driver and, if you vary your boom height, angle data from an inclinometers.

TABLE 4. Bucket Dredge Drivers.

Data	Driver	Assigned to...
Cab Position	GPS.dll (either DGPS or RTK)	Boat
Cab Heading	Any Heading system	Boat
Bucket Position and Depth	A2TS.dll – for variable boom heights LCI90.dll – for cable out	Bucket
Crane Heading	RelHdg.dll provides bucket position relative to the position of the cab.	Barge

The HYPACK® Driver Interfacing Guides, located in your \HYPACK 2018\Help folder, includes detailed configuration information.

FIGURE 11. A2TS Driver Setup Dialog

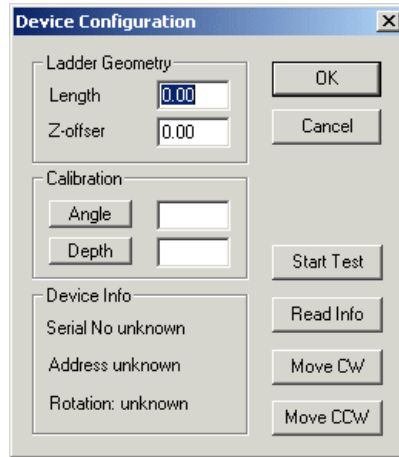

- Place a GPS on the boom.

Data	Driver	Assigned to...
Bucket Position and Depth	GPS.dll (RTK)	Bucket (Boat if cab omitted)
Cab Position (optional)	GPS.dll (DGPS or RTK)	Boat
Cab Heading (optional)	Any Heading system	Boat

FIGURE 12. Sample Bucket Dredge

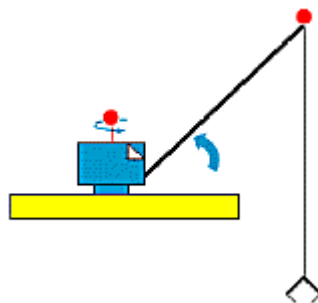

BEWARE!

Accurate bucket depths are very difficult to attain. A postdredge survey is required to measure final channel contours.

A2TSATT.DLL

Version Number: 13.0.10.10

Device Name: A2TS Pitch and Roll

DEVICE SETUP

Heave: Logs pitch and roll data from this device.

DRIVER SETUP

FIGURE 1. A2TSATT Driver Setup

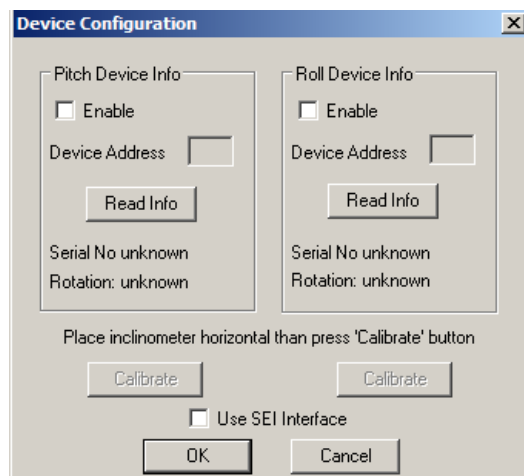

- **Pitch** and **Roll** options enable you to measure Pitch and Roll.
 - For **Pitch**, mount the device parallel to the keel.
 - For **Roll**, mount the device perpendicular to the keel.
- In either case, enter the **Device Address** displayed by the device manufacturer's software.

Calibration:

1. **[Read Info]** gets information from the device about Serial No., Address and Rotation and writes to Device Info. section of Driver Setup dialog.
2. **Check the serial number and address for each device** corresponds to the correct device used for each correction.
3. **Set your inclinometer in a horizontal position and press [Calibrate].** Sets current inclinometer position to Angle=0.

Use SEI Bus:

1. **Enter the Device Address** displayed by the device manufacturer's software.
2. **Click the Read Info box.** This will query the device and return the serial number and direction of rotation.
3. **Check the serial number and address for each device** corresponds to the correct device used for each correction.
4. **Position the sensors as level as possible and click [Calibrate].** This is the baseline reading from which the sensors will calculate the pitch and roll.
5. **Click [OK].**

DEVICE OUTPUT STRINGS

US Digital Proprietary format. Requires their converter to output analog string to HYPACK®.

DRIVER OUTPUT STRINGS

Device Window:

Scrolling display of pitch and roll values. Each value is preceded by its source: [SEI] or [RS232].

Serial Port:

Requests depth data by sending "\x1F".

(See also Special Notes.)

SPECIAL NOTES

Driver Setup:

Event	Message Sent	Message Rec'd	Results
[Read Info]	\xFF and \x03	8 txt members, 1st 2 are \xFF, \x03	Serial Number
	\xFF and \x06 and Serial Number	8 txt members: \xFF \x06 and Serial Number.	Address
	\xFF \x0B	4 txt[] members, 1st 2 are \xFF, \x0B	Rotation

The **A2T** is a single axis, digital gravity angle sensor. The A2T serves as a full 360° range absolute tilt sensor. Internally, a rotary bar coded disk is mounted to a weighted gravity driven wheel. A micro-controller strobes an LED to transfer the bar code image onto an optical linear array, then decodes the position every 4 mSec. Magnetic damping provides fast response and settling time while virtually eliminating overshoot and oscillations. When powered up, it does not require a home cycle, even if the shaft was rotated while the power was off. The **SEI** bus supports distances of up to 1000 feet long.

Connection:

9600, none, 8, 1

BUCKET.DLL

Manual switch to use instead of the F3 key to mark buckets, targets or events, or to start/stop logging.

Version Number: 15.5.0.2

Device Name: Bucket Manual Switch

DEVICE SETUP

Depth: Logs soundings or magnetometer data from this device.

Generate Output Messages: Generates messages or data outside of the Raw file.

This driver draws bucket marks at user-defined locations (F3 or bucket switch) and stores them in a *.BKT file. The location of the previous bucket gives you a visual reference with which to control the next placement.

A Bucket file (*.BKT) is automatically created in your project each day you work with bucket patterns. By default, bucket files are named Date.BKT which contains all of the bucket footprints created in that day.

Use for matrix update: Color-codes a matrix based on the data received from this device.

DRIVER SETUP

GENERAL TAB

FIGURE 1. Driver Setup—General Tab

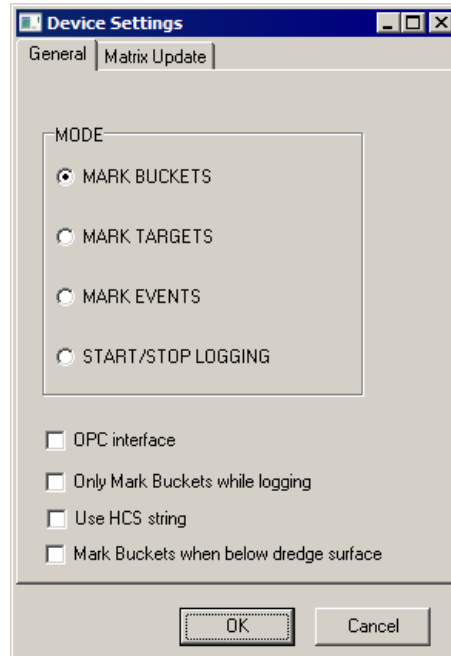

Mode: Tells DREDGEPACK® what operation you want the switch to perform:

- Mark Buckets
- Mark Targets
- Mark Events
- Start/Stop Logging

OPC Interface: Buckets received via OPC connection.

Only Mark Buckets while Logging prevents bucket mark generation when you are not logging data. This requirement (or lack of it) is reflected in the Device Window with the current logging status. This option also restricts targets and events according to your Mode selection.

Use HCS (HYPACK® Crane System) String: Buckets received from the Crane System box.

Mark buckets when below dredge surface: When you enter a matrix cell, the driver reads the dredge depth and marks buckets whenever the bucket is below that original cell dredge depth.

MATRIX UPDATE TAB

IMPORTANT: The depth device attached to the bucket mobile provides the depth to the button. *Its driver must have the Update Matrix function disabled* in the HARDWARE program.

FIGURE 2. Driver Setup—Matrix Update Tab

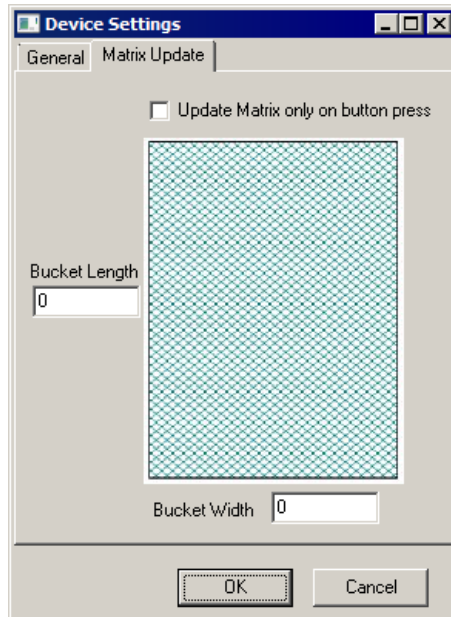

Update Matrix only on button press: Update the matrix when you mark the bucket.

IMPORTANT: Clear the "Update Matrix" option for the depth device.

Bucket Length and **Bucket Width** determine the dimensions of the footprint displayed.

Device Window

FIGURE 3. Options in the DREDGEPACK® Device Window

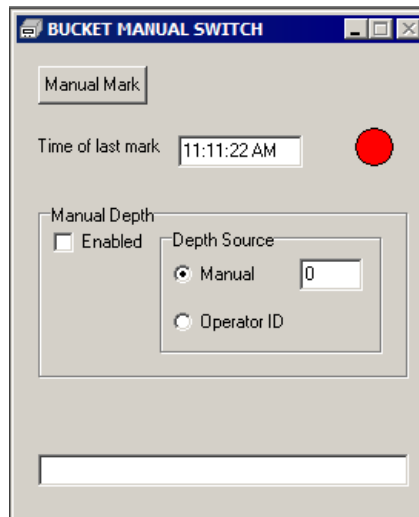

[Manual Mark]: Click the button to mark a bucket, target or event according to your selection in the Driver Setup dialog.

Manual Depth:

Enabled: Overrides depths calculated by the driver based on sensor data with the selected Depth Source value:

- **Manual Depth Source** Paints matrix with user-defined depth set in the Device Window.
- **Operator ID:**

**DREDGEPACK®
Options**

FIGURE 4. *Bucket Parameters*

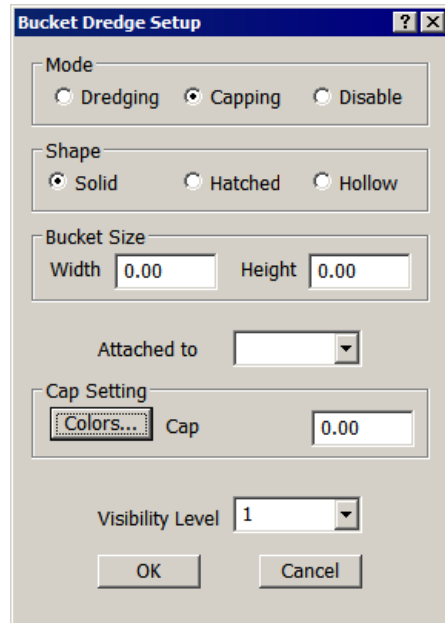

In the DREDGEPACK® interface (OPTIONS-BUCKET PARAMETERS), you can configure the following:

Shape: describes the fill pattern of the footprints displayed on the screen.

Attached to: Designates the mobile on which the digging tool resides. This tells DREDGEPACK® to mark the bucket at the bucket position rather than at the tracking point of the main vessel, which is typically the barge.

Cap Setting: In Capping mode, DREDGEPACK® tracks the number of drops at each location so you know you have achieved even coverage of an area. If you know the approximate change in depth for each drop, you can also estimate how much you have added to any location. It is also used in Capping mode to determine which color footprint to draw. The footprint colors at each location will be incremented with each drop according to the

colors in the Bucket Colors dialog and the user-specified Cap Threshold.

[Colors] accesses the Bucket Colors dialog. Select each color on the left and customize your color scheme using the sliders on the right.

Cap Threshold defines the amount one bucket footprint must overlap another before DREDGEPACK® will increment the color.

For example, we will use the settings Bucket Size = 10 x 10 and Cap Threshold = 0.7. The color will increment if the bucket center is less than 3 units ($1 - 0.7 = 0.3$ which is 30%) offset from the center of all previous bucket footprints in that area.

The first bucket dropped at any position will display a Color 1 footprint. After that, as long as the position of the bucket center for each drop is greater than 3 units (approximately 70% overlap of the bucket as indicated by the Bucket Threshold) away from any other, each of those footprints will also be Color 1. If any subsequent bucket is dropped less than the threshold distance of the bucket width away, the footprint will be Color 2. A third drop within a half-bucket width of the same location will draw in Color 3.

Bucket File Backup Time instructs DREDGEPACK® to automatically save your Bucket file at even time intervals as you work. This prevents loss of excessive data if, for some reason, your system goes down.

Visibility: If you generate bucket patterns regularly, over time, your display is likely to become cluttered with them. You can manage how much of the current day's bucket record is displayed on the screen using the visibility setting and the Clear Bucket icon.

For example: Imagine your display has layers. When you start to work at the beginning of the day, the bucket pattern you create draws to the screen on Layer 1. When you click the Clear Bucket Icon, they move down to layer 2, leaving Layer 1 clean. Each time you click the icon, your patterns all shift downward one layer leaving Layer 1 blank for subsequent patterns. The Visibility option determines how many layers remain displayed in DREDGEPACK®.

In the simplest scenario, Visibility=1. All of the bucket patterns are removed from the display by a simple click of the Clear Bucket icon. They are no longer drawn in your area map, but the records remain in the day's Bucket file.

Consider a more complex scenario. Let's say you are working long days, but you want to see only the patterns from the last three hours. A solution might be to set your Visibility to 3 and click the Clear Bucket icon at the start of each hour. By clicking the icon every hour, at the beginning of the fourth hour, the patterns from

the first hour will advance to the fourth layer. When Visibility is set to 3, it will no longer be displayed.

DEVICE OUTPUT STRINGS

F3 event.

DRIVER OUTPUT STRINGS

Bucket patterns in the SURVEY area map. Buckets for each day are stored, by default to *Date.BKT*.

SPECIAL NOTES

BUCKET DREDGE USES

There are two distinct uses for bucket dredges:

- **Dredging to remove material.** Click F3 each time your bucket reaches the bottom and your project depth colors will be used to color-code bucket foot-prints in the Area Map according to the depth and orientation of your bucket.
- **Capping puts material down.** Click F3 each time you drop material to track the number of drops at each position.

In both applications, the location of the previous bucket gives you a visual reference with which to control the next placement. A Bucket file (*.BKT) is automatically created in your project each day you work with bucket patterns. By default, bucket files are named *Date.BKT*. All of the bucket footprints created in any one day are saved to the day's file. It can be displayed in the area map of DREDGEPACK® and in HYPACK®. They can be automatically saved at even time intervals by setting a bucket file backup time in the Bucket Setup Dialog accessed in DREDGEPACK®.

BUCKET DISPLAY OPTIONS

To configure your bucket display, right-click on the Bucket Files folder in the Project Files list and select solid, hatched or hollow.

CRANE.DLL

The DREDGEPACK® solution for cranes includes a crane control box that integrates readings from a boom inclinometer and a cable counter to produce depth values. This driver does not support the second cable counter that shows the bucket open/close status as crane2.dll does. The bucket will always be displayed as closed.

Version Number: 13.0.1.6

Device Name: Crane Instrumentation System

DEVICE SETUP

Position: Logs position data from this device.

Depth: Logs soundings or magnetometer data from this device.

Heading: Logs heading data from this device.

SURVEY uses the Course Made Good from the VTG, RMC or HDT message, or calculates the vessel orientation based on the change in position over time.

Use for matrix update: Color-codes a matrix based on the data received from this device.

DRIVER SETUP

Setup accessed from DREDGEPACK®.

DEVICE OUTPUT STRINGS

Box reads data from the sensors (angle sensors, cable counter, etc.) and outputs \$CRN string.

\$CRN,0.07,0.67,8,0.00,140.00,0.0

\$CRN,Depth, BucketMark, BoomAngle, HolderLength,
BoomLength,%Open

DRIVER OUTPUT STRINGS

DEVICE WINDOW:

Displays Cable Out, Boom Angle and Depth.

FIGURE 1. Device Window

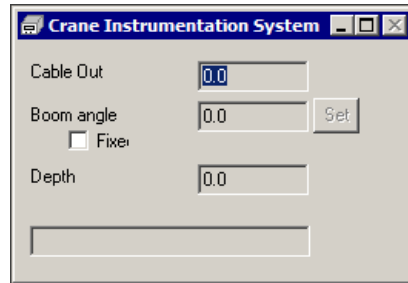

If the angle sensor on the boom breaks, you can manually set a constant angle: Check the Fixed check box and enter your chosen angle.

SPECIAL NOTES

This driver does not support the second cable counter that shows the bucket open/close status as crane2.dll does. The bucket will always be displayed as closed.

CRANE 2.DLL

The DREDGEPACK® solution for cranes includes a crane control box that integrates readings from a boom inclinometer and a cable counter to produce depth values. The new driver works with both the latest version of the Crane Control System and with the previous versions that were not equipped with a second cable counter. In this case, however, the bucket will always be displayed as closed.

Version Number: 14.0.2.4

Device Name: Crane Driver

DEVICE SETUP

Position: Logs position data from this device.

Depth: Logs soundings or magnetometer data from this device.

Heading: Logs heading data from this device.

Use for matrix update: Color-codes a matrix based on the data received from this device.

DRIVER SETUP

OPTIONS TAB

FIGURE 1. Driver Setup—Options Tab

Options | Display | Profile

Footprint File
 ...

Footprint Points Spacing

Bucket Closes in the Y Direction

Bucket Load Table
 ...

Bucket Dimensions

Use bucket mark button to stop painting

Footprint File: *In development.* A spreadsheet that contains information with which the driver calculates the X,Y,Z coordinates of each corner of the bucket for each percentage of bucket opening. This allows DREDGEPACK® to more accurately color-code the matrix based on more precisely calculated bucket size (based on % open) and position rather than a uniformly sized rectangle each time. Place the footprint file.csv in the project folder.

Footprint Points Spacing:

Bucket Closes in the Y Direction: Check when the bucket closes fore and aft vs from left and right.

Bucket Load Table: *In development.* Spreadsheet providing the volume of material in the bucket as a function of the bucket penetration. Place the load file.csv in the project folder.

Bucket Dimensions: Enter the distances indicated in the diagram (survey units).

Use Bucket Mark Button to Stop Painting: Check this option to start stop matrix painting instead of making bucket marks.

DISPLAY TAB

FIGURE 2. Driver Setup

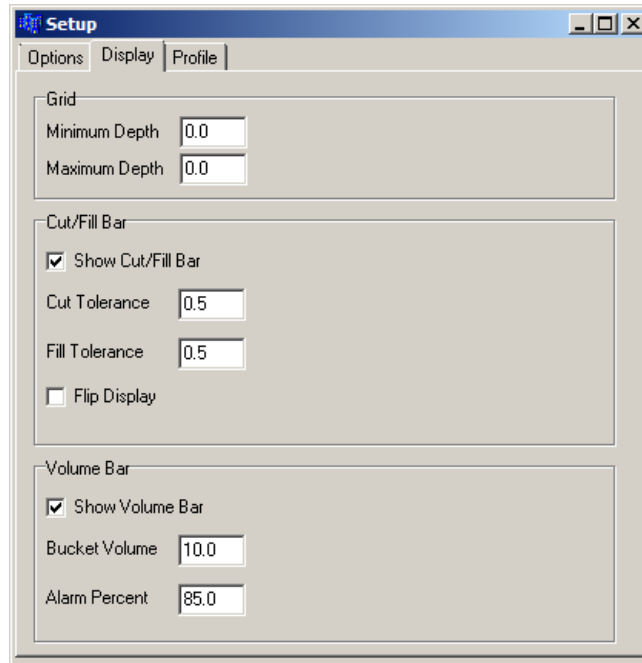

Grid Minimum and Maximum Depths

Cut/Fill Bar:

- **Show Cut/Fill Bar** enables/disables the Cut/Fill Bar display.
- **Cut Tolerance** allowable distance above grade.
- **Fill Tolerance** allowable distance below grade.

The Cut and Fill Tolerance levels define the blue range in the Cut/Fill Bar.

- **Flip Display** inverts the Cut/Fill Bar.

Volume Bar shows a load indicator showing the percentage of bucket capacity that is currently filled. This helps the operator avoid over-spilling of material when the bucket is lowered too much into the bottom.

- **Show Volume Bar** enables/disables the Volume Bar display.
- Bucket Volume
- Alarm Percent

PROFILE TAB

Configure up to three additional profile lines:

FIGURE 3. Driver Setup—Profile Tab

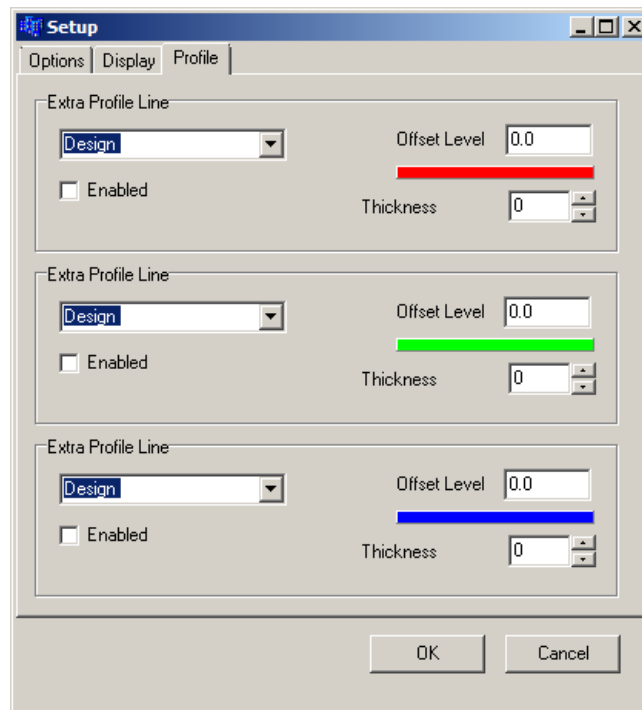

Enable an Extra Profile Line, select the level (Design or Survey) from which you want to offset the extra line, and the offset amount.

You can change the color of each by clicking the corresponding color bar and selecting your color from the colors dialog.

Set the thickness of the line in pixels.

DEVICE OUTPUT STRINGS

Box reads data from the sensors (angle sensors, cable counter, etc.) and outputs \$CRN string.

```
$CRN,0.07,0.67,8,0.00,140.00,0.0
```

```
$CRN,Depth, BucketMark, BoomAngle, HolderLength,  
BoomLength,%Open
```

DRIVER OUTPUT STRINGS

DEVICE WINDOW:

FIGURE 4. Crane2 Device Window

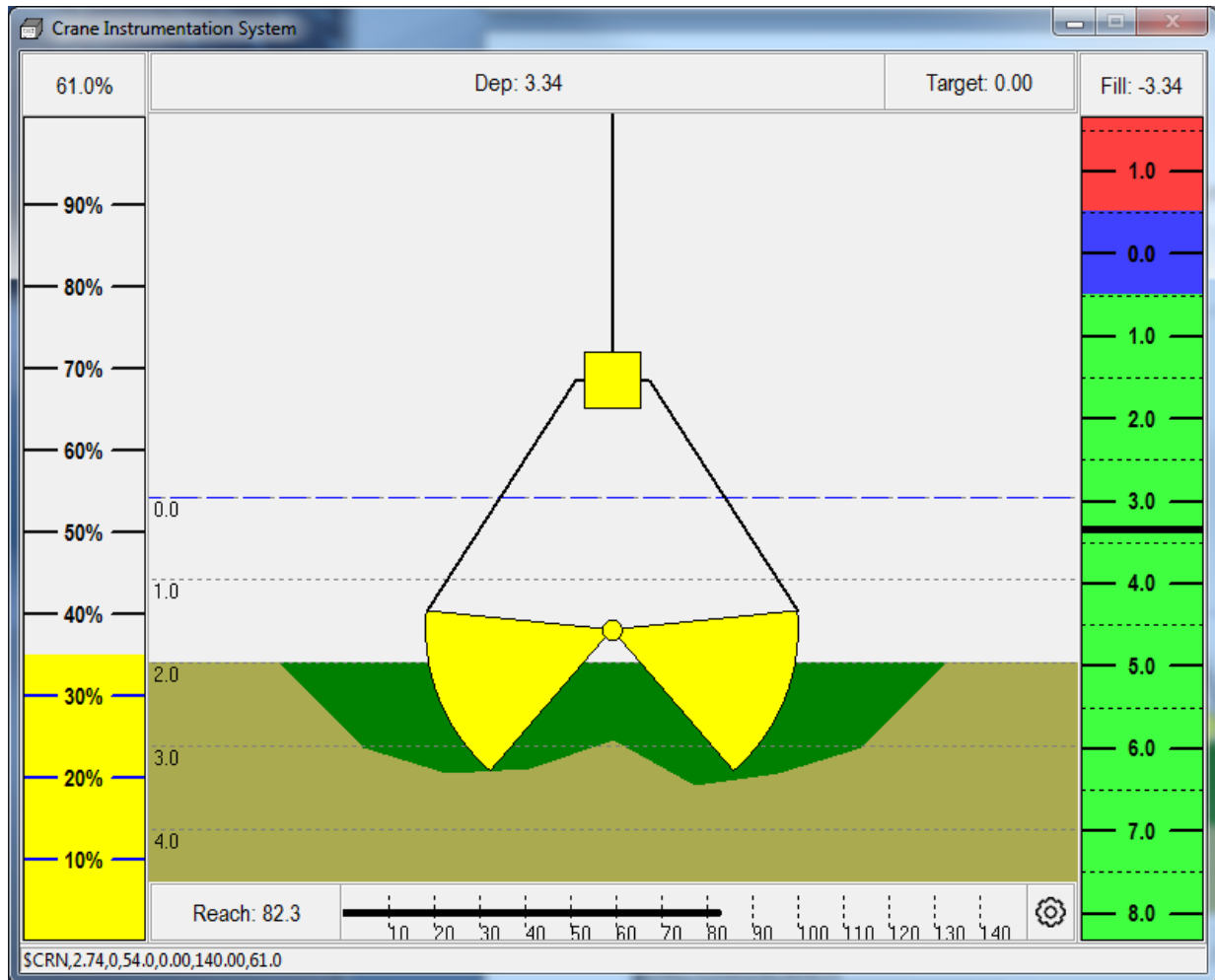

Load Indicator (left) shows the percentage of bucket capacity that is currently filled. This helps the operator avoid over-spilling of material when the bucket is lowered too much into the bottom.

The Cut/Fill Indicator (right):

- **Blue** range corresponds to the required grade,
- **Red** is shallower than grade
- **Green** is deeper than grade.

The **Reach Bar** (bottom) indicates the distance to the bucket from the boom trunnion.

Status bar displays the \$CRN string output from the crane box.

SPECIAL NOTES

See "[New Device Driver for DREDGEPACK Crane Operations](#)"

BOARD CONNECTIONS

- **Power:**
24 volt power and ground
- **Angle:**
Power=red,
ground=black,
=green
- Pitch/roll
- **Operator:**
reset = red
mark = green
black = ground
- **Cable 1 = Holder (up/down)**
Power=red,
ground=black
signal 1 return=green
signal 2 return = white
- **Cable 2 = open/close**
Power=red,
ground=black,
signal 1 return=green
signal 2 return = white

NOTE: Crane2.dll updates matrix based on bucket open/close. Not just a uniform rectangle based on bucket dimensions because the bucket doesn't remove bottom material uniformly; some left in the center (particularly if it doesn't fully close) and on the outside edge where bucket teeth curve in.

[Cutting tool display always shows bucket to show operator open/close status. May not agree with orientation of bucket (displayed in the map window).]

CUTTER.DLL

Version Number: 14.0.6.2

Device Name: Cutter Dredge

This driver reads data from Shared Memory and uses it to draw rear or right profile views of the dredge at work.

The advantages to using the cutter driver window in lieu of the standard Dredge Profile window while dredging:

- It allows you to Zoom and Pan within the profile window with simple keyboard commands.
- It allows you to import a custom shape that accurately depicts the shape and size of your dredge.

DEVICE SETUP

Generate Output Messages: Generates messages or data outside of the Raw file.

In this driver, it generates the improved profile view in the driver's device window.

NOTE: This driver inherits its position and depth information from the mobile to which it is assigned.

DRIVER SETUP

The device window is a profile view of your dredge. These options configure the device window display.

[Profile View]	<p>Load and scale a boat shape file (*.SHP) for each mobile view. A sample set of shapes may be found in the HYPACK® install folder under \Boat Shapes\Shapes for the Cutter Driver. The driver initially loads default sizes, but you should change them to match the measurements of your dredge.</p> <p>When you generate your own shape files:</p> <ul style="list-style-type: none"> It is important to make them accurately to scale so the display in DREDGEPACK® will be accurate. You can scale them by entering a percentage value under Size for each shape. (If there's no value, the program assumes 100%.) If you need to modify these default boat shapes beyond changing the scale, simply open them in the BOAT SHAPE EDITOR and make the necessary modifications as per your vessel's dimensions.
[Rear View]	
[Arm Profile]	
[Arm Rear]	
2-Segmented Ladder	
[Arm2 Profile]	
[Arm2 Rear]	
[Cutter Head]	

FIGURE 1. Driver Setup Dialog

Display Setup

	File Path	Size
Profile View	C:\Hypack 2011\Boat Shapes\Shapes for the Cutter Driver\body_prof.shp	25
Rear View	C:\Hypack 2011\Boat Shapes\Shapes for the Cutter Driver\body_front.shp	15
Arm Profile	C:\Hypack 2011\Boat Shapes\Shapes for the Cutter Driver\arm_prof.shp	15
Arm Rear	C:\Hypack 2011\Boat Shapes\Shapes for the Cutter Driver\arm_front.shp	5

Two Segmented Ladder

Arm 2 Profile:

Arm 2 Rear:

Cutter Head: C:\Hypack 2011\Boat Shapes\Shapes for the Cutter Driver\cutter.shp, Size: 3

Profile Width: Min. Depth: Boat Color:

Cell Size: Max. Depth: Cutter Color:

Main Vessel:

Depth Source: Center of Head Bottom of Head

Drawing Options:

Disable Matrix Update Disable Drawing Hull Disable Drawing Arm Disable Drawing of Head Disable Head Tilt

OK Cancel

FIGURE 2. Sample Cutter Head SHP File

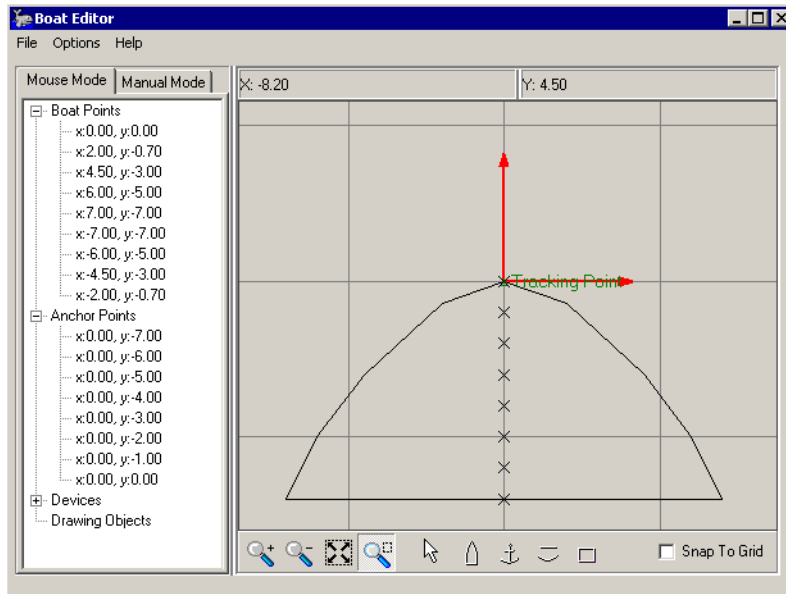

Size: Multiplier to scale the boat shape to real measurements.

Profile Width: Half of the specified width will extend on either side of the cutter head.

Cell Size: Determines how the Cutter driver will resize your matrix and display this surface in the Profile Window. If you are working with a very small resolution matrix, it may be necessary to scale back this Cell Size, but the default Cell Size of 1 works well.

Min. Depth and Max. Depth: Set the depth range for the Profile window display

Boat Color and Cutter Color: Set the fill colors for the shape files in the DREDGEPACK® Profile window.

Main Vessel ID: should define the barge. The Cutter position is *relative to* the main vessel.

Depth Source based on the radius of the head.

- **Center of Head**
- **Bottom of Head**

The driver knows that when you are in elevation to invert the display and show the higher number closer to the top of the display. When in depth mode the Min Depth will be closer to the top of the display.

The '**Drawing options** remove objects from the device window display.

- **Disable the Matrix Update:** Check this when the cutter head depth device is updating the matrix. DREDGEPACK® then calculates points in the shape a ring at each anchor point and

uses them for matrix update. If the 'Disable Matrix Update' option is cleared, DREDGEPACK® can update only one point at a time.

- **Disable the drawing of the HULL**
- **Disable the drawing of the ladder arm**
- **Disable the drawing of the cutter head**
- **Disable the tilt of the head in relation to the depth:** Draws the cutter head parallel to the horizon.

DEVICE OUTPUT STRINGS

None. The Cutter driver gets position and depth from the mobile to which it is assigned. It draws the device window display based on the driver setup options.

DRIVER OUTPUT STRINGS

DEVICE WINDOW

FIGURE 3. Sample Device Window

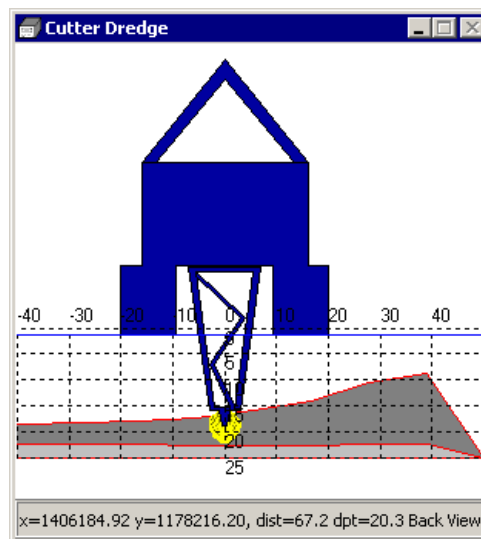

Some of the 'Disable options' from the driver setup, as well as some others, are also available from DREDGEPACK®.

To access the configuration dialog, right-click in the window and select 'Config'.

FIGURE 4. Device Window Configuration Dialog

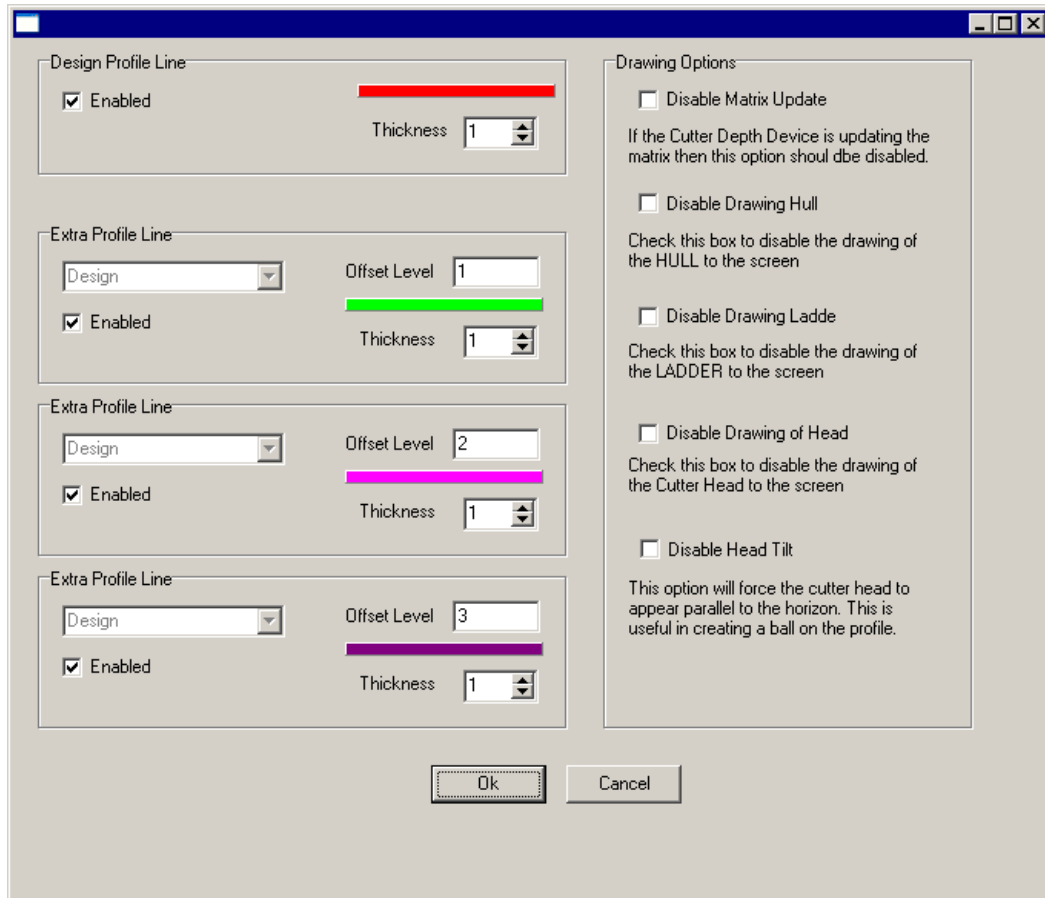

Choose to draw the design profile and up to 3 additional profiles, each offset from the design grade by its Offset Level amount to guide the operator in how much material to lift at a time and to avoid burying the cutter head. When setting an offset line above the design and you are in elevation the offset is entered as a negative number.

Select a **color** and **thickness** (pixels) for each enabled profile.

To choose a profile color, click on its color bar and select a new color in the colors dialog.

Drawing Options: Disable any part of the excavator you wish to omit from the display tab.

EXCAVATOR.DLL

Version Number: 15.0.1.1

Device Name: Excavator

DEVICE SETUP

Position: Logs position data from this device.

Depth: Logs soundings or magnetometer data from this device.

Heading: Logs heading data from this device.

SURVEY uses the Course Made Good from the VTG, RMC or HDT message, or calculates the vessel orientation based on the change in position over time.

Generate Output Messages: Generates messages or data outside of the Raw file.

Use for matrix update: Color-codes a matrix based on the data received from this device.

DRIVER SETUP

GENERAL TAB

FIGURE 1. Driver Setup - General Settings Tab

Excavator Type: US Digital T-7

Use SEI Interface

Measurements:

Boom Length	Stick Length	Stick 2	Bucket Length
10	10	5	5

Body Length** 10

Sensor ID Assignment:

Boom Sensor	Stick Sensor	Stick2 Sensor	Bucket Sensor
0	0	0	0

Sensor Override Values:

Boom	Stick	Bucket
0	0.0	0

BKT Matrix Angles: 0 0
Set to 0.0 to disable

Auto Bucket Down Depth Increment: 0
Set to 0.0 to disable

Excavator Type: Indicate whose system you are using.

- **RVG/Etrac:**
- **HYPACK®:**
- **Ocala Instruments:** The driver works with either Ocala output string.
- **US Digital T-7**
- **Custom:** Generates an additional 'Custom Parser' tab where you can describe how to parse a comma or space delimited text string containing the boom, stick and bucket angles. It also enables the Sensor Type options; choose the type of angle sensor you have installed.
- **Simulator:** Simulates excavator data for testing purposes.
- **Mixed Setup:** Supports the user of more than one sensor type.

Measurements:

The main part of the excavator that includes the engine and the operator cabin is referred to as the **body** of the excavator. The first

arm segment is the **boom**, the second arm segment is the **stick** and the third arm segment is the **bucket**.

IMPORTANT: All measurements are between the pin centers.

Measurements:

- **Boom Length:** Distance from boom pin to stick pin
- **Stick Length:** On a 3-segment arm, the distance from stick pin to bucket pin.
- **Stick 2:**
- **Bucket Length:** Distance from the boom pin to the bucket teeth when the teeth of the bucket are resting on the barge deck.
- **Body Length:** *For presentation purposes only. Accuracy is not required.*

Sensor ID Assignment: For each sensor, enter the sensor ID number from the hardware configuration.

Tip:

To display the sensor ID in HARDWARE, select OPTIONS-SHOW DEVICE ID. The ID precedes the device name in the configuration tree.

Sensor Override Values: For each sensor, you can override the sensor value by checking the corresponding box and entering the override value. This would typically be used for testing purposes only. The driver can also make partial calculations with only boom and stick angles so, if you're bucket sensor is not working correctly, you can enter a bucket override value and continue to work on approximate bucket positions.

NOTE: The tip of the bucket should be on the deck of the dredge for calibration.

Bucket Matrix Angles: These values represent the angle between the bucket and the stick. Enter the range where DREDGEPACK® should update the matrix. This can be useful to update the matrix only when you are actively digging.

AutoBucket Down Depth Increment: The driver adds the depth increment to the matrix depth at that location to calculate the projected bucket depth. When the bucket reaches the calculated depth, it automatically marks a bucket at that location.

BUCKET GEOMETRY

FIGURE 2. Bucket Geometry Tab—Placing the Angle Sensor on the Bucket

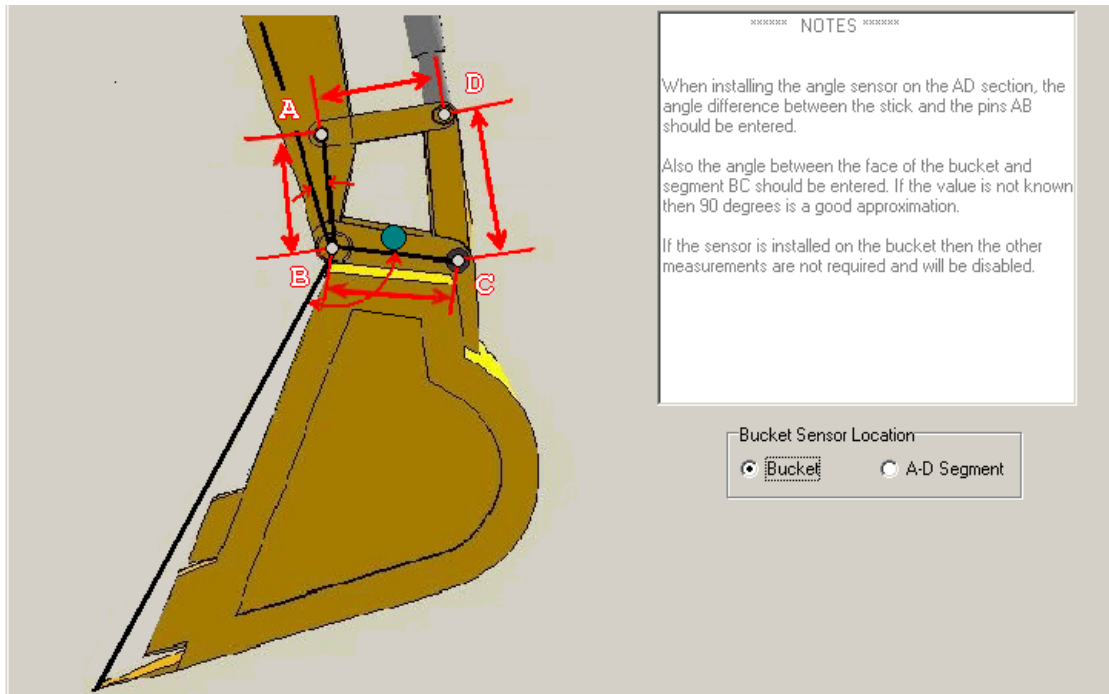
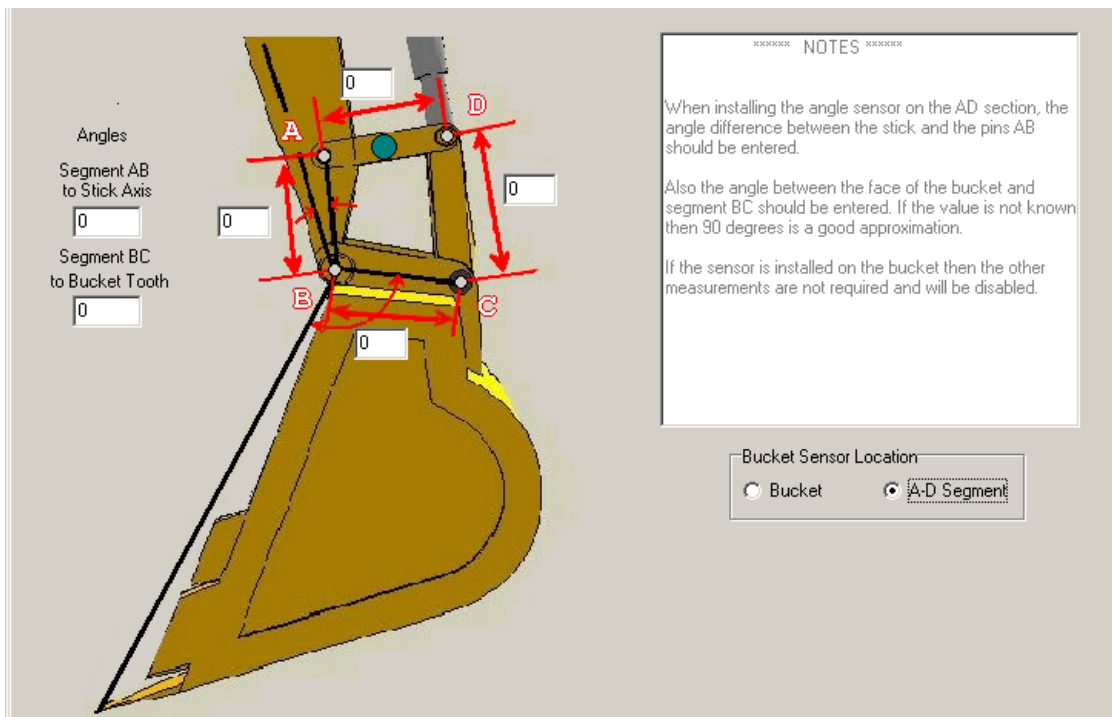

FIGURE 3. Bucket Geometry Tab—Placing the Angle Sensor Above the Bucket



Bucket Sensor: Indicate where the bucket sensor is mounted.

- **Bucket:** If the sensor is installed on the bucket the other measurements are not required and will be disabled.
- **A-D** refers to the labels on the diagram. When this option is selected, more fields appear for the distances and angles required.
 - The distances AB, BC, CD and DA.
 - The angle from the stick and the AB pins, and from the BC pins and the front edge of the bucket. If the angle is unknown, 90 degrees is a good estimate.

PROFILES/SHAPES

FIGURE 4. Profile/Shapes Tab

Grid Options:

- **Minimal Depth** and **Maximal Depth** set the vertical range.
- **Profile Width** sets the horizontal range in survey units.
- **Boat Position:** The distance (in survey units) from the left side of the Profile display where you want to view the barge.

Control Lines: Draw lines at user-defined positions in the device window display to provide visual reference.

- **Horizontal Mark 1 and 2** mark horizontal lines at the user-defined depths.
- **Overdredge** marks a the overdredge depth of your channel.

- **Pontoon Protector** places a vertical line forward of the cabin center. Use it to mark the pontoon position and keep your bucket from crossing the line. If the teeth are too close, an alarm sounds in DREDGEPACK®.

To customize the colors in the Profile display:

1. **Click the color square** corresponding to the object for which you want to choose a color. A Color Selection dialog will appear.
2. **Choose the new color and click [OK].**

Select the HYPACK® boat shape file (*.SHP) which will represent each part of the excavator. The driver defaults to a set of shapes provided with the HYPACK® install (\Hypack 20xx\Boat Shapes\Shapes for the Excavator Driver). However, you can use your own, custom shapes created in the BOAT SHAPE EDITOR. By design, the shapes connect to each other. The scale of the drawing does not matter; the size is controlled by the size entry in the device driver.

To load shapes other than the default shapes:

1. **Under ‘Select the Shapes for each element’, click the button corresponding to the shape you want to load.** A File Open dialog will appear.
2. **Select your new SHP file and click [Open].**

QUICK ATTACHMENT TAB

Designed for any Quick Disconnect installation.

FIGURE 5. Quick Attachment Tab

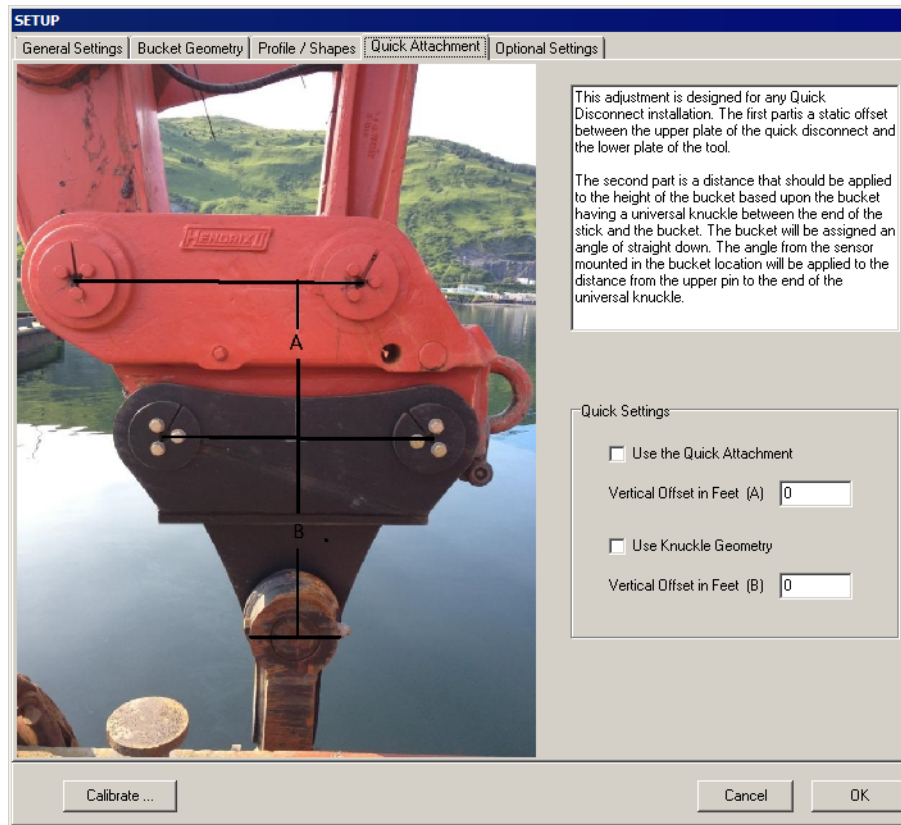

Use the Quick Attachment and Vertical Offset in Feet (A): The static offset between the upper plate of the quick disconnect and the lower plate of the tool.

Use Knuckle Geometry and Vertical Offset in Feet (B): The distance that should be applied to the height of the bucket based upon the bucket having a universal knuckle between the end of the stick and the bucket. The bucket will be assigned an angle of straight down. The angle from the sensor mounted in the bucket location will be applied to the distance from the upper pin to the end of the universal knuckle.

OPTIONAL SETTINGS TAB

FIGURE 6. Driver Setup—Optional Settings Tab

The screenshot shows the 'Optional Settings Tab' with the following sections:

- Sensor Adjustments - Used to offset angles received from the sensor:**
 - Boom Angle Offset: 0, Multiplier: 0,
 - Stick Angle Offset: 0, Multiplier: 0,
 - Bucket Angle Offset: 0, Multiplier: 0,
 - The method for calculating the offsets is: $\text{Angle} = (\text{raw angle} * \text{multiplier}) + \text{offset}$
- Grapple Settings:**
 - Distance: 5, Enable Grapple:
 - Direction in Degrees: 71, Fixed Angle:
 - Mark Bucket on Grapple Close
 - Distance Threshold: 0.2, Reach Threshold: 0.2, Time Threshold (ms): 2000
- Filtering:**
 - Filter factor: 0.8 (0.0 <= factor <= 1.0, 0 - minimum filtering, 1 - maximum filtering, 0.8 - recommended)
 - Boom Angle
 - Stick Angle
 - Bucket Angle
- Reach Adjustment:**
 - Reach: Minimum 0, Maximum 0
 - Adjustment: 0, 0
 - Enabled:

Enable each feature you want to apply with the corresponding the check box and enter the parameter value for your configuration:

Sensor Adjustments: Enables you to apply an offset and multiplier to the value from the angle sensor. Allows you to correct an erroneous angle value by a constant value.

To use the Sensor Adjustments feature, check the check box for the offsets you want to apply and enter the corresponding offset and multiplier values. If your sensor does not use the 360 degree convention to measure a circle, enter a multiplier to convert the measurements to 360 degrees. Enter a -1.0 multiplier to reverse the angle.

Filtering: A low-pass filter that enables you to dampen changes in the angles. The filters allow the angle jumps, caused by rough water, to be dampened, which allows you to better see where the tool is. The values in the Filter section range from 0 (minimum filtering) to 1.

NOTE: Filtering of angles is ignored during calibration.

Reach Adjustments: When you reach as far out as possible with the bucket on the surface, the depth should be zero. Likewise, when you bring the bucket as close to the barge as possible and touch water, it should read zero, but this doesn't account for the pitch caused by the arm moving out and back.

When you enable the reach adjustments, you must also enter the range of the reach from the trunnion to the teeth on the bucket, and the corresponding adjustment value.

Grapple Settings:

- **Enable Grapple** changes the calculations for the grapple design.
- **Distance:** Enter the distance from bucket pin to the tip of the stationary side of the grapple.
- **Direction:** The angle difference from the stick to the stationary side of the grapple.
- **Fixed Angle:** Check if the grapple is at a fixed angle from the stick.
 - **When this option is checked,** you must enter the angle between the stick and the grapple (on the side of the grapple away from the bucket) and the grapple length in the distance field.
 - **When this option is clear,** the angle comes from a sensor on a hydraulic connector, but you must enter the grapple length in the **distance** field.
- **Mark Bucket on Grapple Close:** The driver automatically generates a bucket mark when the grapple closes. The distance and reach thresholds define when a bucket is closed.
 - **Distance Threshold:** Difference between grapple and stick depths.
 - **Reach Threshold:** Difference between grapple and stick reaches.
 - **Time Threshold (ms):** Frequency of buckets marked while grapple is closed.

CUSTOM PARSER TAB

The Custom Parser tab appears only if you have selected the 'Custom' Excavator Type on the General Settings tab. Use the options to describe the string the driver will read from your device.

FIGURE 7. Custom Parser

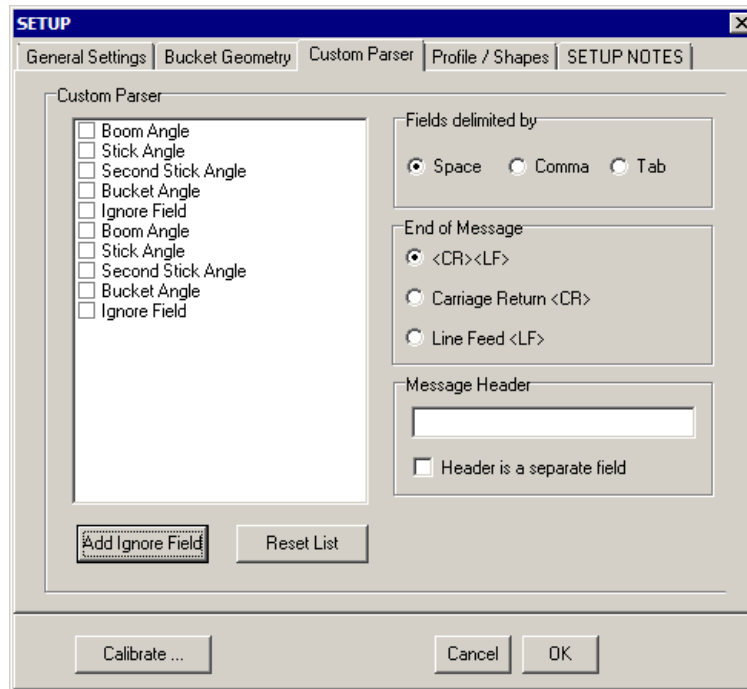

Custom Parser: Check the values the driver will parse. Put them in string order by dragging them in the list with your cursor. If you need to ignore more than one field in your string, use [Add Ignore Field] to generate additional 'Ignore Field' list items.

Fields delimited by: Set the item that separates values in your string.

End of Message: Set what indicates the end of a string.

Message Header: Device output messages often begin with a particular set of characters. If this is the case for your device, enter that string here and check '**Header is a separate field**'.

DEVICE OUTPUT STRINGS

Each according to the Excavator Type selected in the driver setup.

DRIVER OUTPUT STRINGS

DREDGEPACK® AREA MAP

FIGURE 8. Excavator With Bucket and Arm Drawn to the Map Window

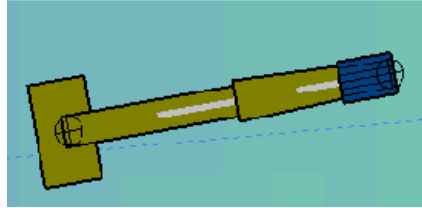

DEVICE WINDOW

DISPLAY TAB

The display tab shows the position of the excavator in real time as you work. You assign the boat shapes for each part of the excavator in the driver setup, but the remaining settings are controlled from the device window.

FIGURE 9. Display Tab

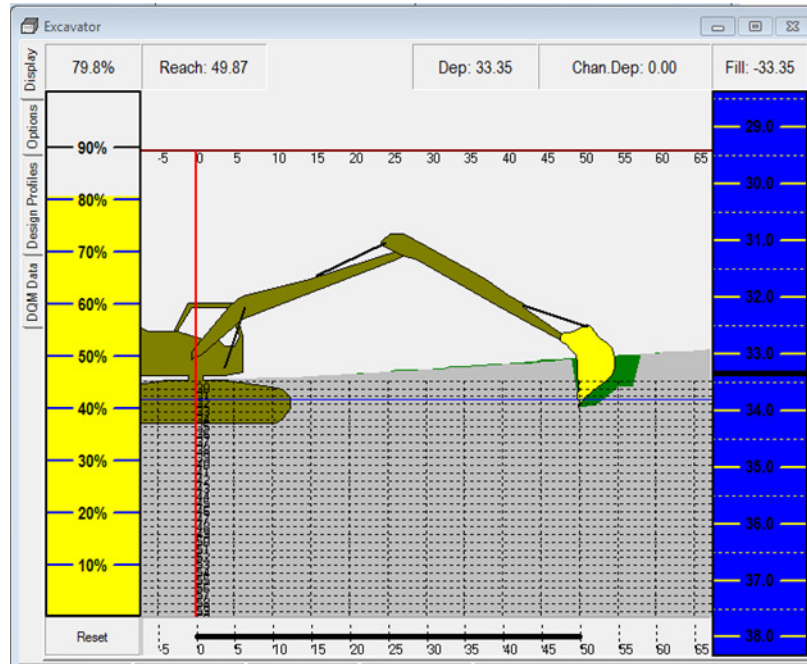

Volume Bar: Of the material that the pre-dredge survey shows to be above design grade, this is the percentage that remains.

Cut/Fill Bar: Monitor the bucket position relative to design grade (0). Configured in the [“Options Tab”](#).

Reach Bar (bottom): Horizontal reach of the bucket from the trunnion.

Pontoon Protection (red vertical line) marks pontoon position and triggers an alarm if the bucket gets to close.

Monitoring Angle Sensors: The status bar shows the current angle for each sensor. “Faulty” indicates sensor failure.

DATA TAB

The Data tab displays a table of the length and angle measurements for each segment of the excavator arm.

FIGURE 10. Data Tab

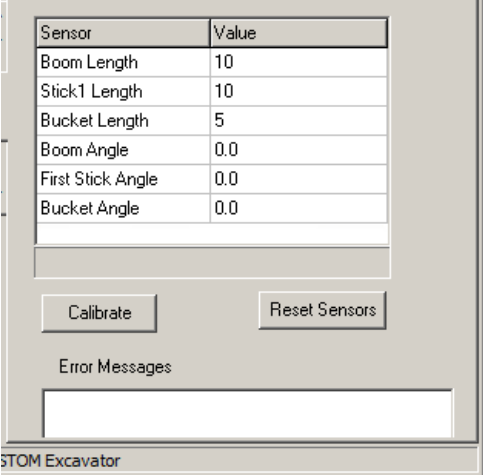

Sensor	Value
Boom Length	10
Stick1 Length	10
Bucket Length	5
Boom Angle	0.0
First Stick Angle	0.0
Bucket Angle	0.0

Calibrate Reset Sensors

Error Messages

STOM Excavator

[Calibrate]: See [“Calibration Procedure”](#).

[Reset Sensors]: If there’s a problem with the sensors, [Reset Sensors] turns the power to the sensors off then on in an attempt to restart the system.

OPTIONS TAB

The Options tab configures what you see in the Display tab.

Enable Cut/Fill Bar toggles the display of the Cut/Fill Bar.

Enable Reach Bar toggles the display of the Reach distance at the top of the display.

Enable Volume Bar toggles the display of the Volume Bar. It shows an estimate of the volume in the current bucket based on the calculated depth and the Bucket Volume specified on the Options tab.

Cut/Fill Bar Options:

- **Cut Tolerance:** Distance of the grade color below 0.
- **Fill Tolerance:** Distance of the grade color above 0
- **Source:**
The purpose of the Design Profiles is to allow you to use a survey surface as the basis for your dredging. In this case, the

goal is to remove material to a constant level below the original survey surface.

- **Channel Depth:** Channel template as defined by the predredge survey.
- **Mark 1 Depth:** A straight horizontal line at a user-defined depth.
- **Design Profile 1, 2 and 3:** Parallel below the channel depth.

Track Bucket centers the display on the bucket position. Otherwise, the display is centered on the cab.

Display Bucket Depth includes the bucket depth at the top of the display.

Draw Bucket on Map draws the bucket mobile in the DREDGEPACK® Area Map according to the dimensions supplied in the setup.

Draw Boom/Stick on Map draws the broom and stick between the excavator cab and bucket shapes in the DREDGEPACK® Area Map.

Colors and Grid Options are the same as in the Driver Setup. (See “Profiles/Shapes”.)

Volume Options:

- **Bucket Volume:** Amount the bucket will hold.
- **Volume Alarm:** Shows an alarm in the DREDGEPACK® window when the estimated volume of the material exceeds this percentage of the Bucket Volume.

SPECIAL NOTES

IMPORTANT: *Vessel origin is always at the boom pin.*

- **Vertical Offset:** The distance from the trunnion to the water as the vertical offset.
- The standard sensor type is a Gravity Based Inclinometer.
- If using Potentiometer, pitch correction is required.
- The Potentiometer is a relative angle to the previous attached segment.
 - The **boom** is relative to the horizontal level.
 - The **stick** is relative to the boom.
 - The **bucket** is relative to the stick.
- When using the RVG/eTrac Sensors you *must* have the SEI_EXPLORER software loaded from US Digital. It can be found in the \HYPACK 2018\Support\Utilities folder.

- Supports display of excavator in 3DTV. All you have to do is start Matrix-3DTV in DREDGEPACK® and the driver outputs the items required by the program to show the excavator in 3D.
- Does not send calibration data to the excavator box system.

SENSOR LOCATION:

Sensors are usually placed on the side of the excavator arm that the operator can see so he can monitor for damage.

- The **Boom** sensor is usually placed on the boom arm so that the sensor rotates with the axis of the boom, above the hydraulic ram attachment to minimize the possibility of damage.
- The **Stick** sensor is located just below the stick-to-boom pin on the stick, along the axis of the stick rotation. This allows the cable to be aligned with the hydraulic hoses in a way that will minimize damage.
- The **Bucket** sensor presents a new set of problems. The sensor is best used when it is placed on the top of the bucket. The cable requires enough slack to avoid damage to the cable when the bucket is rolled.

FIGURE 11. Angle Sensor Positions

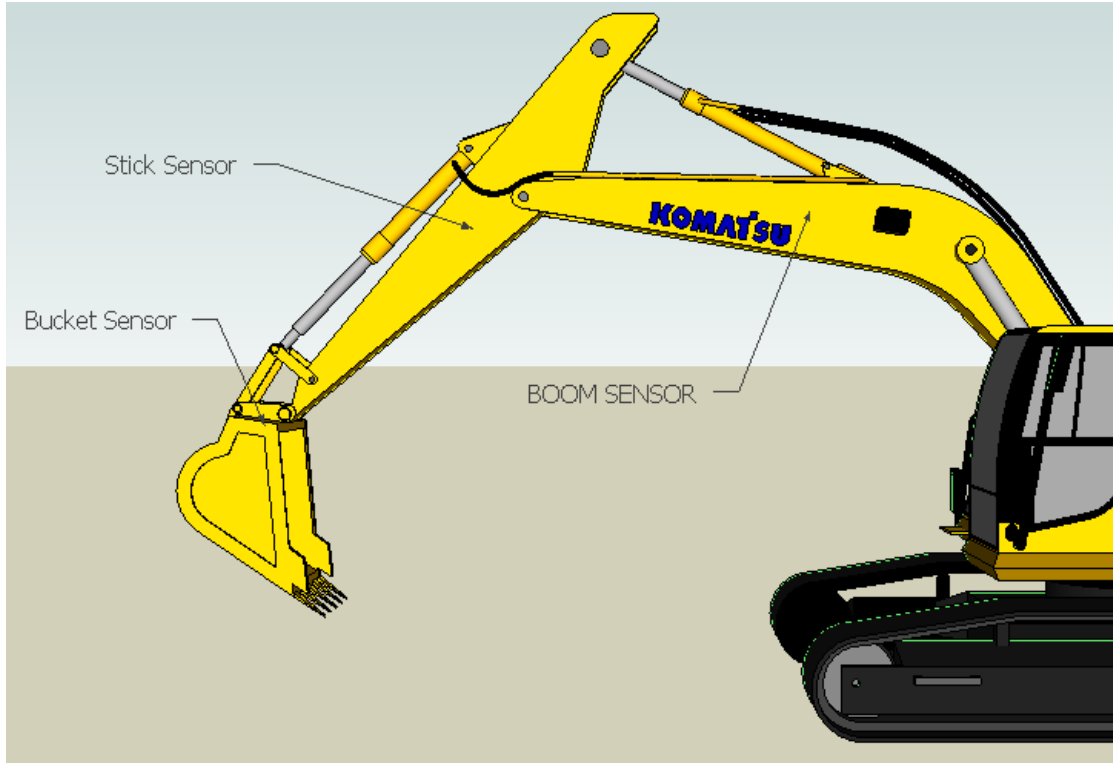

The excess cable should be located near the boom sensor to keep the slack out of the way.

CALIBRATION PROCEDURE

Click [Calibrate] to launch the Calibration dialog.

There are 2 methods, one on each tab:

- **3 Segment X Cal:**

FIGURE 12. Calibration Dialog—X Cal Tab

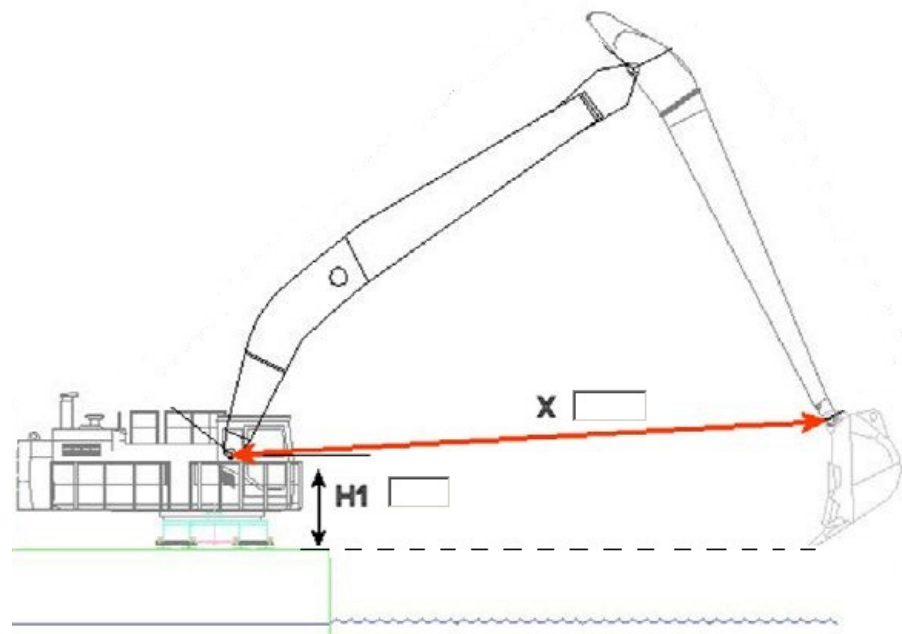

- Set the bucket vertical with the teeth directly beneath the bucket pin.
 - Measure the vertical difference between the tip of the bucket teeth to the center of the boom pin and enter it as **H1**. The bucket teeth may be at the level of the barge or water surface (or any other repeatable surface).
 - Measure the distance from the boom pin to the trunnion and enter it as **X**.
 - Click [Calibrate].
 - Click [Exit] to return to the Excavator Driver Setup.
- **Height Calculation:**

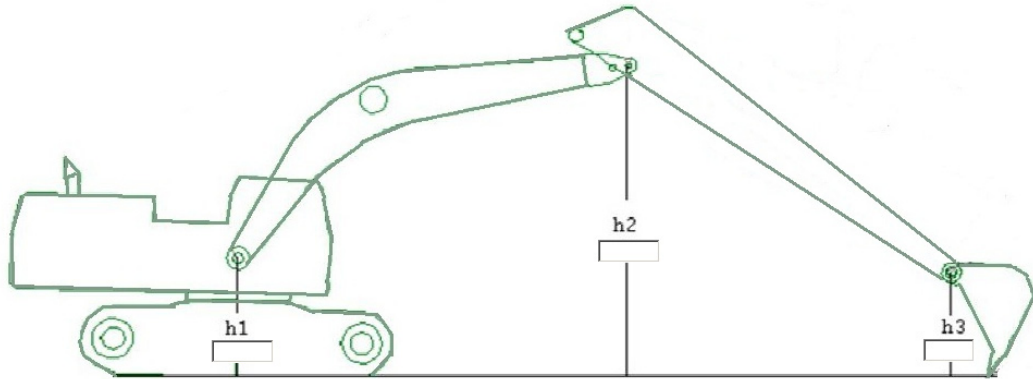
FIGURE 13. Calibration Dialog—Ht Cal Tab

- a. Set the tip of the bucket teeth on your vertical reference. You can use the barge deck, the water surface or any other horizontal surface you can accurately measure.
- b. Measure the height from the horizontal reference to each pin and enter the measurements in their corresponding fields (h1, h2, and h3).
- c. Click [Calibrate].

Either set of measurements enables the driver to calculate the bucket position and an adjustment constant for each sensor to arrive at a bucket depth of zero.

Tip:

When you calibrate with the teeth at the same vertical height as the excavator tracks, when the teeth are on the water surface, the corrected depth equals the tide.

HD25A.DLL

HD25a optical rotary position sensor. Reports the shaft angle within a 360 range to give us the heading of the cutter arm separate from heading of the barge.

Version Number: 14.0.2.4

Device Name: U.S. Digital HD-25A Horizontal Angle Sensor

DEVICE SETUP

Heading: Logs heading data from this device.

DRIVER SETUP

FIGURE 1. Driver Setup

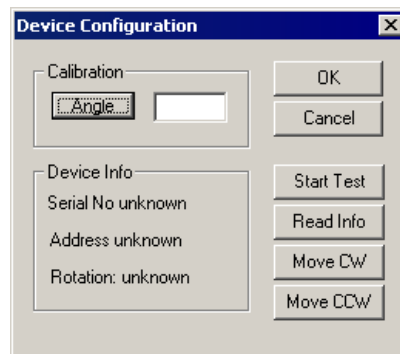

[Angle]: Put the sensor at a horizontal position pointing straight ahead, enter "0" in the Angle Calibration field and click [Angle] to set at angle=0.

[Start Test]: Verifies data is being received.

[Read Info]: Reads a string from the sensor and displays the Device Information.

[Move CW] and **[Move CCW]:** Reverses the angle of the sensor without having to remount the sensor in the opposite orientation. Can also be corrected in SEI Explorer.

DEVICE OUTPUT STRINGS

Proprietary hexadecimal string.

DRIVER OUTPUT STRINGS

DEVICE WINDOW:

Scrolling display of Heading data.

SERIAL PORT:

Initialization string queries the device for each record with:

\$1RD

SPECIAL NOTES

FIGURE 2. HD25A Angle Sensor

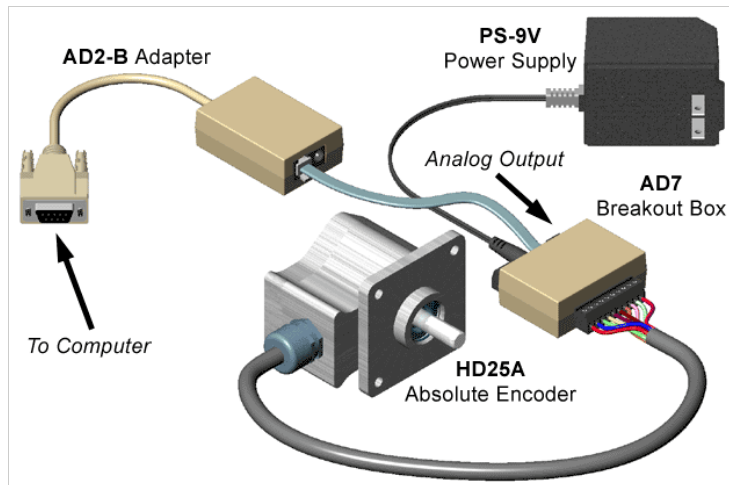

The **HD25A** is a rugged absolute encoder designed for heavy duty industrial use. This absolute encoder is a non-contacting optical rotary position sensor which reports the shaft angle within a 360° range. When powered up, it does not require a home cycle, even if the shaft was rotated while the power was off. The **SEI** bus supports distances of up to 1000 feet long.

The device is a heading sensor for a separate mobile in HYPACK®. Put the device at the attachment point of the cutter arm to the barge.

1. Configure the devices for the main vessel so that a heading and position are available.
2. Add a separate mobile for the object to be tracked.
3. Add the Genoffsets.dll to provide a position to the object. Remove the check mark in the Heading of the Genoffsets device. This frees the heading from main vessel heading.
4. Add the HD-25A driver.
5. Connect the driver to the proper port.
6. Calibrate the driver using the Angle button in the device Setup.

INNERSPACEBUBBLER.DLL

Version Number: 9.0.0.1

Device Name: Innerspace Bubbler Gauge

DEVICE SETUP

Position: Logs position data from this device.

Heading: Logs heading data from this device.

Depth: Logs soundings or magnetometer data from this device.

Use for matrix update: Color-codes a matrix based on the data received from this device.

DRIVER SETUP

FIGURE 1. Driver Setup in SURVEY

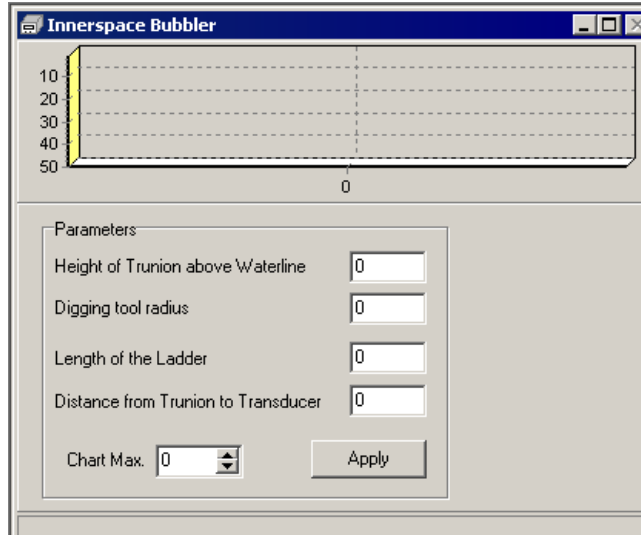

The driver setup is done in its Device Window in SURVEY.

Enter and apply the measurements (in survey units) for your dredge.

- **Height of Trunnion above Waterline**
- **Digging Tool Radius**
- **Length of the Ladder**

- **Distance from Trunnion to Transducer**

Chart Maximum: The Device Window in SURVEY shows a display of the cutting tool depths. The graph ranges from 0 to a user-defined depth--the Chart Maximum. The display will automatically increase the depth range to the maximum depth read plus one, if the current depth range is not sufficient to display the depths received.

These values can be adjusted, if necessary, during calibration. Any changes made here during SURVEY will not be used by the driver until you click **[Apply]**.

Status Bar displays:

- Time
- Depth Received
- Computed Depth
- Effective Ladder Length (EL)

DEVICE OUTPUT STRINGS

Measured depths formatted as:

*+nnnnn.nn

DRIVER OUTPUT STRINGS

DEVICE WINDOW:

The SURVEY screen shows the values used to compute the depth. The scrolling graph shows the last 50 readings.

SPECIAL NOTES

Designed for Cutter Suction dredges.

LCI90CS.DLL

Version Number: 9.0.1.4

Device Name: Line Control Instrument 90 Clam Shell

DEVICE SETUP

Depth: Logs soundings or magnetometer data from this device.

Use for matrix update: Color-codes a matrix based on the data received from this device.

DRIVER SETUP

FIGURE 1. Driver Setup9

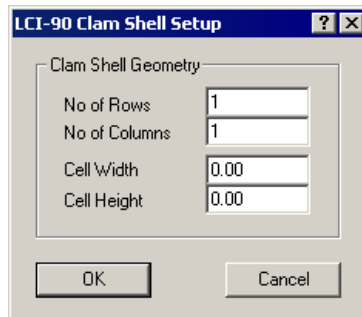

Clam Shell Geometry allows the device to paint more than one cell of a matrix. Imagine the bucket footprint is a grid of rows and columns.

No of Rows and **No. of Columns:** number of rows and columns in the bucket footprint.

Cell Width and **Cell Height:** Define the size (survey units) of each cell in the grid.

DEVICE OUTPUT STRINGS

```
RD,-TTTTT.TT,-SSSS.SSS,-PPP.PPPP,CCCC<CR><LF>  
(RD,Tension,Speed,Payload,checksum<CR><LF>
```

DRIVER OUTPUT STRINGS

DEVICE WINDOW:

Writes original line.

Writes "Calibration: tide=*Tide*, offset=*Offset*, height=*Height*" where:
Tide read from boat info.

Offset= ellipsoid ht.– payload.

Height = ellipsoid ht. from boat info.

Formats depth to 2 decimals and writes:

"depth(raw) =*Depth*".

If driver can't read any strings, it writes
"Calibration Error" to the device window.

SERIAL PORT:

Query device string: (for "polled" mode only)

<CR>

SPECIAL NOTES

Has its own menu with only a "Calibration" option.

Error Messages:

If driver can't read any strings, it writes "Calibration Error" to the device window.

SWINGIND.DLL

For Cutter Suction Dredges to show the relative swing of the ladder (in degrees) relative to the boat mobile. On a normal dredge this is taken from the planned line azimuth to the heading of the ladder, regardless if it is a swing ladder.

Version Number: 13.0.9.12

Device Name: Cutter Swing Indication

DEVICE SETUP

Generate Output Messages: Generates messages or data outside of the Raw file.

Strictly a display driver. There is no raw data recorded.

DRIVER SETUP

None.

DEVICE OUTPUT STRINGS

None.

DRIVER OUTPUT STRINGS

DEVICE WINDOW:

Controls both the amount of swing and the source from which it computes the angle.

The Settings Tab controls both the amount of swing and the source from which to compute the angle.

FIGURE 1. Settings Tab

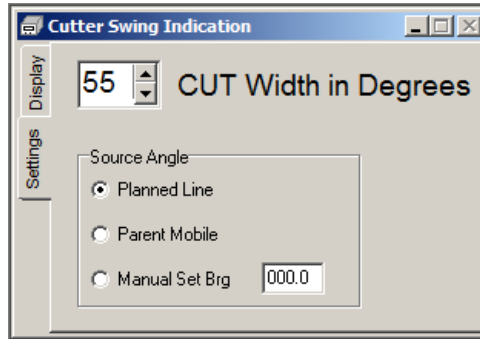

Cut Value is the total width of the swing (cut/2 on each side of center. Green in the display tab).

Source Angle:

- **Planned Line:** Reports difference between the heading of the line and the vessel.
- **Parent Mobile:** Reports angle relative to the dredge.
- **Manual Set Bearing (Brg):** Reports difference between the user-defined heading and the vessel heading.

FIGURE 2. Display Tab

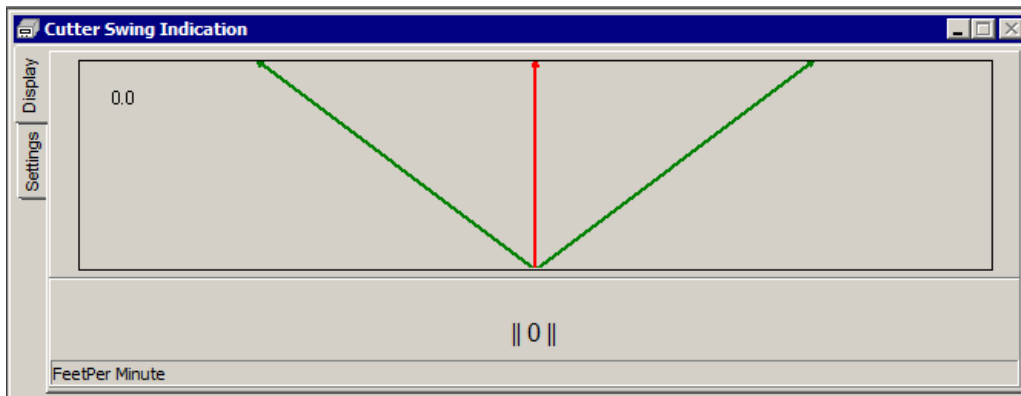

Green is the Cut Angle.

Red is the position of the cutter head.

Blue is the designated center line.

Value lower center shows speed and direction of the cutter head motion. The units are set by right-clicking on the status bar and selecting feet/min or feet/sec.. The right-click menu also includes an option for you to set the font of this part of the display.

[Set Center] updates the center line angle to the current vessel heading.

VULCAN.DLL

This driver uses the information in the driver setup to more accurately fill a matrix in DREDGEPACK®. The position and size of the bucket tells DREDGEPACK®, in more detail, what area is at the measured depth. The Vertical and Horizontal Spacing values create a grid (with nodes spaced according to these values) the size of the bucket footprint and places a sounding at each node in the grid rather than 1 sounding at the measured bucket position.

Version Number: 14.0.2

Device Name: Vulcan

DEVICE SETUP

Depth: Logs soundings or magnetometer data from this device.

Use for matrix update: Color-codes a matrix based on the data received from this device.

DRIVER SETUP

FIGURE 1. Driver Setup

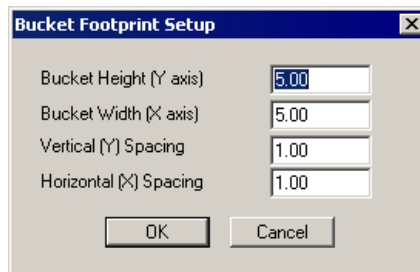

Bucket Height and **Bucket Width:** the dimensions of the bucket footprint.

Vertical Spacing and **Horizontal Spacing** interval between recorded depths.

Mobile # assigns mobile number to the bucket.

DEVICE OUTPUT STRINGS

None. Reads water depth data from Navinfo structure.

DRIVER OUTPUT STRINGS

DEVICE WINDOW:

On each depth , writes:

```
"Mobile#: BucketNumber Total: NumberOfDepthsInFootprint
```

SPECIAL NOTES

Footprint pattern is centered on tool position both for odd and even number of rows or columns.

Camera Drivers

•

Camera drivers may be used to take photographic images at regular intervals during your survey.

In HYSWEEP® surveys, the images can be coordinated with the survey data based on the time stamp in post-processing so you can see the captured topography side-by-side with your sounding data. This can be particularly useful to supplement the point cloud displays of LiDAR data.

Additionally, if you load the camera images to your project (in the JPEG Files folder) an icon appears in the map display at the position of each image, and you can view the image and its metadata from the Project Items list.

CANONINTF.DLL

Version Number: 17.2.0

Device Name: Canon EOS Image Capture

DEVICE SETUP

Generate Output Messages: Generates messages or data outside of the Raw file.

This driver outputs image files at user-defined picture interval. Each image is recorded with a time stamp to \HYPACK 2018\Projects*ProjectName*\Images\ImgLog.log, which facilitates the correct image display with the corresponding survey data in the 64-bit HYSWEEP® EDITOR.

DRIVER SETUP

FIGURE 1. Driver Setup

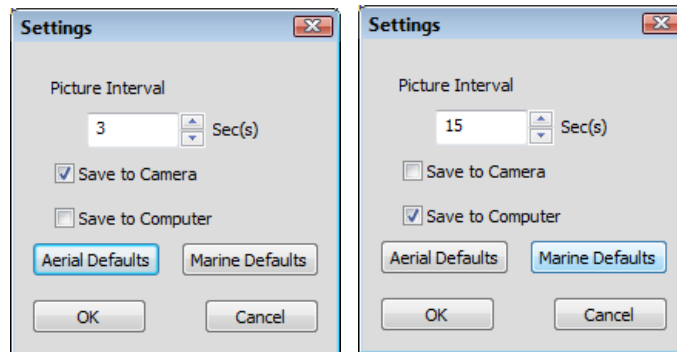

Picture Interval: The time interval between pictures taken automatically *while you log data* in HYPACK® SURVEY.

To take pictures manually, set the Picture Interval to 9999 Sec(s) then click [Take Picture] in the Device Window as needed.

Intermittent Manual Pictures: You can use [Take Picture] even when the driver is automatically taking pictures. In this case, the camera continues to capture images at the defined interval in addition to the added manual pictures.

Save to Camera/Save to Computer choose where the HYPACK® SURVEY stores the image files. You can choose one or both options.

- **Save to Camera:** Recommended for the short picture intervals typical on UAVs, because it is faster to write to the SD card in the camera.
- **Save to Computer** stores the images to the project \Images folder. (C:\HYPACK 2016\Projects\YourProjectName\Images.)

With one click, the defaults buttons set the Picture Interval and Save options to reasonable options for aerial or marine vessels:

- **[Aerial Defaults]:** Picture Interval of 3 Sec(s) and Saves to Camera
- **[Marine Defaults]:** Picture Interval of 15 Sec(s) and Saves to Computer

DEVICE OUTPUT STRINGS

None.

DRIVER OUTPUT

DEVICE WINDOW

Provides [Take Picture], for manual picture taking, and shows the last captured image with its associated timestamp.

SPECIAL NOTES

- Requires the Canon SDK file (EDSDK.dll) in the HYPACK® install folder.

SUPPORTED CANON DSLR CAMERAS IN HYPACK

- EOS 5DS / EOS 5DS R / EOS REBEL T6s / EOS 760D / EOS 8000D / EOS REBEL T6i /
- EOS 750D / EOS Kiss X8i / EOS M3
- EOS-1D C / EOS M / EOS 6D / EOS M2 / EOS 7D Mark II
- EOS-1D X / 1D Mark III / 1Ds Mark III / 1D Mark IV
- EOS 40D / 50D / 5D Mark II / 5D Mark III / 7D / 60D / 60Da / 70D
- EOS Kiss X2 (Rebel XSi/450D)
- EOS Kiss F (Rebel XS/1000D)
- EOS Kiss X3 (Rebel T1i/500D)
- EOS Kiss X4 (Rebel T2i/550D)

- EOS Kiss X5 (Rebel T3i/600D)
- EOS Kiss X6i (Rebel T4i/650D)
- EOS Kiss X50 (Rebel T3/1100D)
- EOS Kiss 7i (Rebel T5i /700D) / EOS Kiss 7 (Rebel SL1/100D)
- EOS Kiss X70(Rebel T5/1200D/Hi)
- EOS Kiss X70(Rebel T5/1200D/Hi)

PHYSICAL CANON DSLR CAMERA CONNECTION WITH HYPACK®

Connecting a supported Canon DSLR with HYPACK® is plug-and-play. Just plug a USB cable into the camera and the HYPACK® computer. Turn the DSLR camera on and let Windows® recognize it as a device (verified on Win7/8/10 64-bit platforms).

FIGURE 2. Connecting the Canon DSLR Camera via USB to the HYPACK Computer.



MANUAL FOCUS FOR SHORT PICTURE INTERVALS

If the Canon DSLR is programmed to take pictures with a short interval in between (e.g. Rapid Shooting Intervals < 5 seconds) it is *highly* recommended that you initially set your focal length, allow the camera to autofocus, *then switch to manual focus mode.*

BEWARE!

If the DSLR is set to Auto Focus while using a short interval, the camera *will not* release the shutter since it is actively and continually trying to focus the lens.

Depending on the Canon lens, you may find it necessary to operate in Manual Focus mode even at longer picture intervals (e.g. between 5 – 10 sec). Auto Focus speeds can vary on Canon lens models.

NOTE: You should monitor the “Last Pic” field of the camera window in HYPACK® SURVEY to confirm that pictures are being successfully taken at the specified interval.

IMAGES IN POSTPROCESSING

The images (photos) are time stamped via HYPACK® and can be correlated in MBMAX64 (64-bit HYSWEEP® EDITOR) for further review via the Image LOG File.

FLIR THERMAL.DLL

Version Number: 17.1.0

Device Name: FLIR Thermal Camera

DEVICE SETUP

Generate Output Messages: Generates messages or data outside of the Raw file.

Sends GPS, MRU and time syncing to camera. (See

DRIVER SETUP

FIGURE 1. Driver Setup

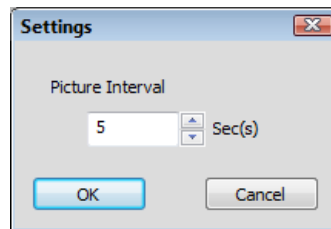

Picture Interval (sec.): Time interval between photos.

Until the required firmware upgrade, the FLIRThermal driver can only send the data to be embedded in the image files, but it cannot automate the image capture process nor generate the LOG file that enables the 64-bit HYSWEEP® EDITOR to display the image corresponding to the data at the cursor location during postprocessing.

Set the Picture Interval to 0, and start/end taking pictures using the Record button, both in the FlirThermal SmartPhone App.

CONNECTION SETTINGS

When connecting the camera, cut the MAVLink cable and connect it to a USB to TTL cable to communicate with device. (See [“FLIR Thermal Camera” article](#) appended to this document.)

On the Connect tab, set the COM port and baud rate of the TTL and camera.

DEVICE OUTPUT STRINGS

None.

DRIVER OUTPUT

A series of photos on the camera's micro-SD card with Latitude, Longitude, Altitude and Attitude embedded inside a JPG image.

DEVICE WINDOW:

The driver dialog will display a message every time the driver sends the position and attitude to the camera (once a second) and, when SURVEY controls the image interval, every time the driver sends the command to take a picture.

PORT

Sends GPS, MRU and time syncing to camera.

SPECIAL NOTES

POST-PROCESSING FLIRTHERMAL IMAGES

Copy your JPG images from the camera to the project \Images folder. HYPACK® places an icon in the Map window according to the positioning data embedded in each image.

When you query such an icon, HYPACK® displays the corresponding image in a pop-up window.

HOW TO CONNECT

You connect to the FLIR camera through its MAVLink connection. To do so, you need to do a bit of work to the accessory cable:

Cut the Mavlink end off the accessory cable and connect it to a TTL to USB cable as shown below in the pictures. (If the Rx and Tx are reversed (nothing appears in WCom32 test), you can fix this by using a double null connection.

Tip: Wiring both the accessory cable and TTL-to-USB cable with RS232 to plugs makes it easier to add a serial cable for extra length and maneuverability, if necessary.

While you can set the baud rate in the iOS or Android app., it's recommended to just leave it at its default of 56700.

FIGURE 2. FLIR Camera Connections—Connect A to B, then modify the MAVLink connector (1) with the RS232

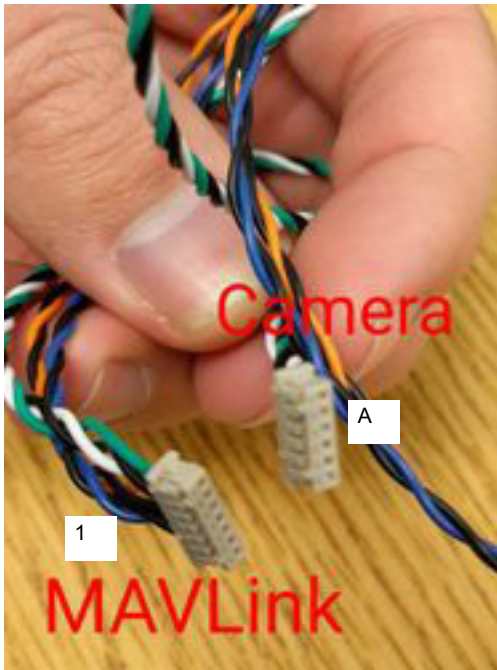
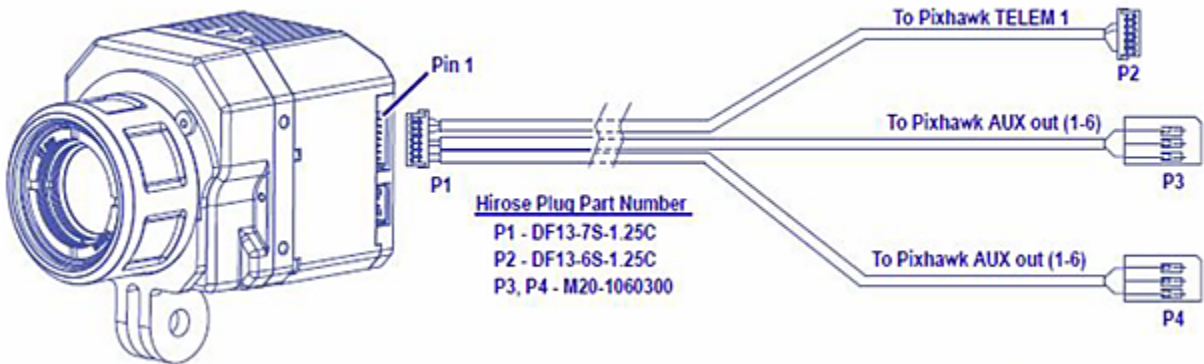

FIGURE 3. FLIR Wiring Information



P1 - Accessory Port		Wire color	P2 - TTL to USB		P3 - Not used		P4 - Not used	
PWM_1	1	green	RX in					
PWM_2	2	white	TX out					
GND	3	black	GND					
PWM_3	4	orange		→ PWM_3	1			
GND	5	black		→ GND	3			
PWM_4	6	blue				→ PWM_4	1	
GND	7	black				→ GND	3	

FIGURE 4. (1) FLIR Accessory wire wired to RS232 connector, (2) Serial cable (optional) provides length, (3) TTL-to-USB connects from the serial connection to the survey computer.

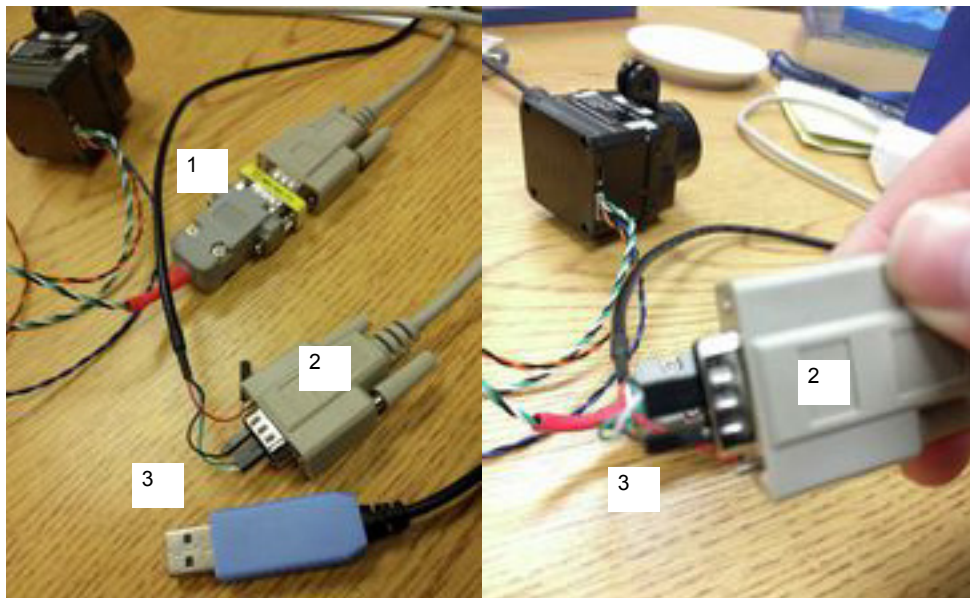
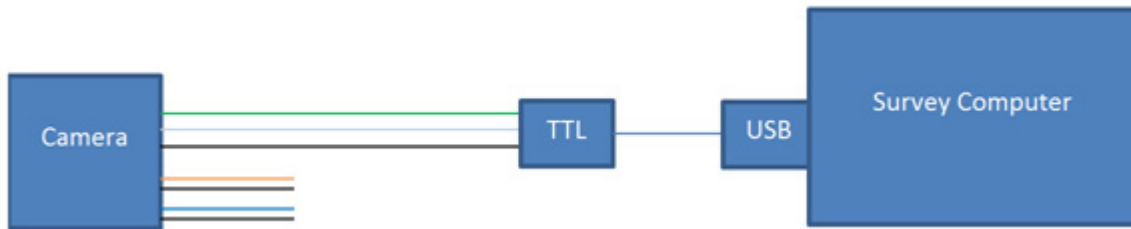

FIGURE 5. System Diagram



HARDWARE CONFIGURATION

In HARDWARE, add the FLIR Thermal Camera driver to the vessel from which you want to get the position.

Currently the FLIR firmware doesn't read the commands from SURVEY to take pictures; however it will still accept the position and attitude. In the Device Setup dialog, check the Generate Output Messages function for the driver to send the position and attitude to the camera. In the Driver Setup window set the Interval to 0 until the FLIR firmware can be updated.¹

On the Connect tab, set the COM port and baud rate of the TTL and camera.

FIGURE 6. FLIR Driver Setup

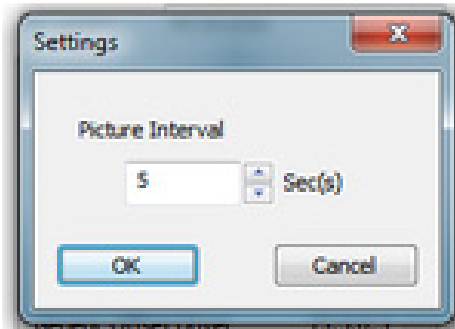

ANDROID/IOS APP SET UP

1. Install the FLIR UAS app.

1. When the FLIR firmware update is released, SURVEY will send the command to take pictures at the interval specified in the Driver Setup, and the `Imglog.log` file will store the image name, date and time. The `Imglog.log` is then used in the editor to coordinate the image display with the data in the editor windows.

- **Android:** <https://play.google.com/store/apps/details?id=com.flir.vuepro&hl=en>
 - **iOS:** <https://itunes.apple.com/us/app/flir-uas/id1051901140?mt=8>
2. **Connect to the camera through your phone or tablet.**
 - a. First you have to **start the camera's Bluetooth** by pressing the button on the side.

FIGURE 7. Starting the Bluetooth Connection on the Camera



- b. **Select SETTINGS-ACCY PORT, make sure MAVLink is selected as Serial Protocol.** This is also where you may change the baud rate. HYPACK supports all 3 choices, but 57600 is the default for the FLIR Vue Pro.
- c. **Back out of Settings to the main screen.**
- d. **Select the Still option.**
- e. **Set the Interval**, moving the slider toward the right until the desired interval (in seconds) appears at the right. (When SURVEY controls the interval, this option should be single (0) as in Figure 8.)
- f. **Select your color palette and scene.** Then you should be set up on the app.

FIGURE 8. Configuring the Camera in the FLIR Application

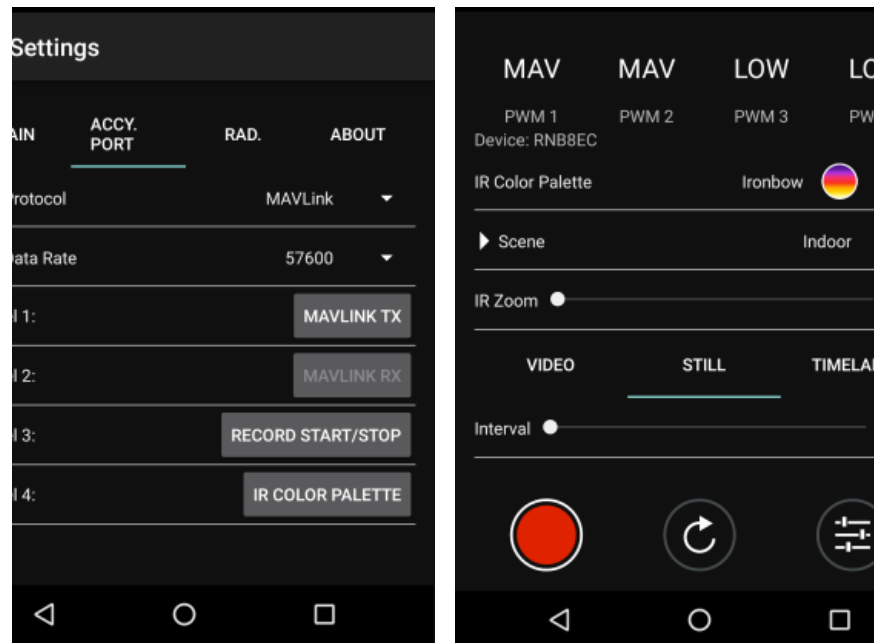

RUNNING IN SURVEY

The camera doesn't send images or video back to SURVEY, so you won't see anything the camera is seeing in the device window. Instead, the driver dialog will display a message every time the driver sends the position and attitude to the camera (once a second) and, when SURVEY controls the image interval, every time the driver sends the command to take a picture.

Until the firmware is upgraded, you'll need to trigger the photos to be taken yourself either pressing the rec button on the camera or the red record button in the app. You can stop the photos from being taken the same way.

Once the firmware update is released, SURVEY will control the picture taking and, with each picture while logging, it will display the time of the image in the Device Window.

RESULT

In the end you should end up with a series of photos on the camera's micro-SD card with Latitude, Longitude, Altitude and Attitude embedded inside a JPG image.

When the firmware is upgraded, SURVEY will also generate an image log (ImgLog.LOG) which is used to coordinate the images with the survey data in post-processing.

GoPro_CAPTURE.DLL

Version Number: 15.0.0.4

Device Name: GoPro Capture

DEVICE SETUP

Generate Output Messages: Generates messages or data outside of the Raw file.

Logs each photo to the goprolog.log. (See [“Driver Output Strings”](#).)

DRIVER SETUP

FIGURE 1. Driver Setup

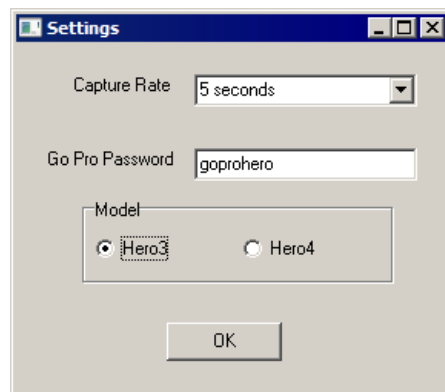

Capture Rate: Time interval between photos.

Go Pro Password: If you have not changed the camera's defaults the password will be "goprohero". It will be the same as its WiFi password.

Model: Camera Model

DEVICE OUTPUT STRINGS

None. Photos are stored in the camera and are coordinated with the LIDAR data based on the time-stamp in the goprolog.log.

DRIVER OUTPUT STRINGS

Logs photo name and time driver sent logging command to goprolog.log in the project \Images folder:

PhotoName Date msecPastMidnight

where the date is in MMDDYYYY format.

DEVICE WINDOW

- **Hero 3** shows the GoPro Video feed.
- **Hero 4** does not support video display. The device window shows when the last photo was taken.

SPECIAL NOTES

- Connect the WiFi of your computer to the camera. This is done like connecting to a wireless router.
- In the device test window the Go Pro Hero 3 shows a video feed from the camera if everything is working correctly. The Hero 4 does not support the video display.
- At the end of the survey, manually remove the photos from the camera either via a USB cable or by removing the Micro SD card from the camera and using a card reader.

Drivers with Other Functions

3DLRIND.DLL

The 3D Left/Right Indicator displays an interactive, 3D view of a boat shape and its position relative to the planned survey line.

Version Number: 16.1.1

Device Name: 3D LR Indicator

DEVICE SETUP

None.

DRIVER SETUP

FIGURE 1. Driver Setup

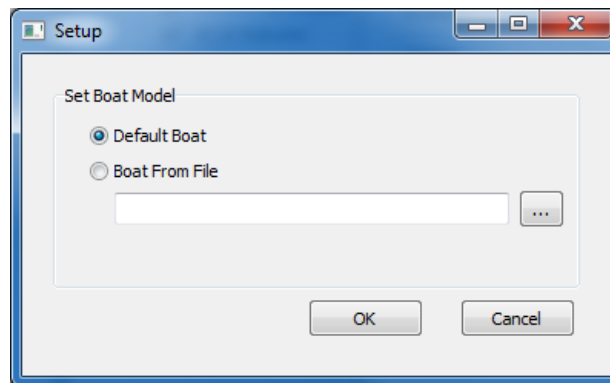

Use the default boat shape or select Boat From File and load a custom boat shape (*.3OD) generated in the 3D SHAPE EDITOR.

DEVICE OUTPUT STRINGS

None

DRIVER OUTPUT

DEVICE WINDOW:

FIGURE 2. Sample Device Window

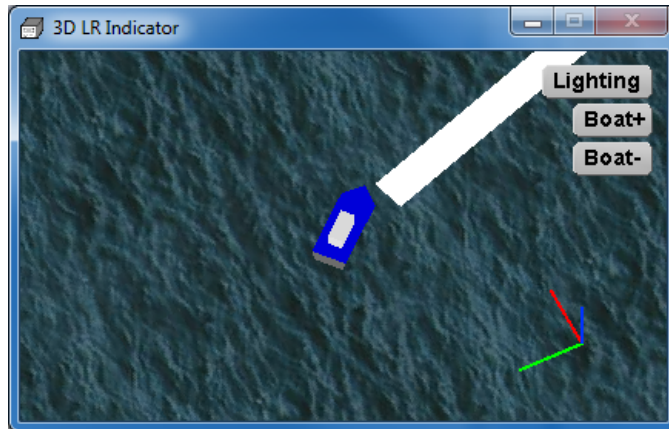

[**Lighting**] opens the Lighting Controls with which you control the color and position of the lighting for optimal viewing of your model. The lighting in the Light Control, as well as in your model window will update according to each setting change.

FIGURE 3. Light Control

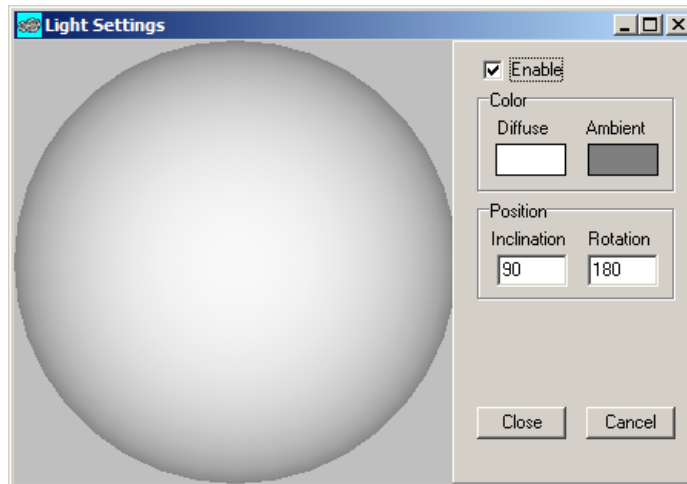

Color: Click on either color block to access a color dialog where you can select your favorite color for each option.

- **Diffuse** color comes from the light source.
- **Ambient** sets the color of the light that brightens the entire display. It is similar to the brightness setting in your favorite graphics program.

Position:

- **Inclination** is the angle of the light relative to the horizon.
- **Rotation** is the position around the Z-axis of the model.

Together they describe the exact position of the light source relative to the model.

Rather than puzzling out what the angles should be, you can imagine that the shape on the left is your vessel, then use your cursor to click where you would like the light source to be positioned relative to your model.

[Boat+] and [Boat-] adjust the scale of the boat shape.

SPECIAL NOTES

This display can significantly slow drawing performance in SURVEY.

ADCP.DLL

Version Number: 17.1.1

Device Name: ADCP

DEVICE SETUP

Position: Logs position data from this device.

Select position only when you intend to use bottom tracking.

Depth: Logs soundings or magnetometer data from this device.

Use for matrix update: Color-codes a matrix based on the data received from this device.

Generate Output Messages: Generates messages or data outside of the Raw file.

In this driver, it is required to generate the *. ADCP files that contain the binary ADCP data.

DRIVER SETUP

FIGURE 1. Driver Setup - SonTek Tab (left), RDI Tab (center), Rowe (right)

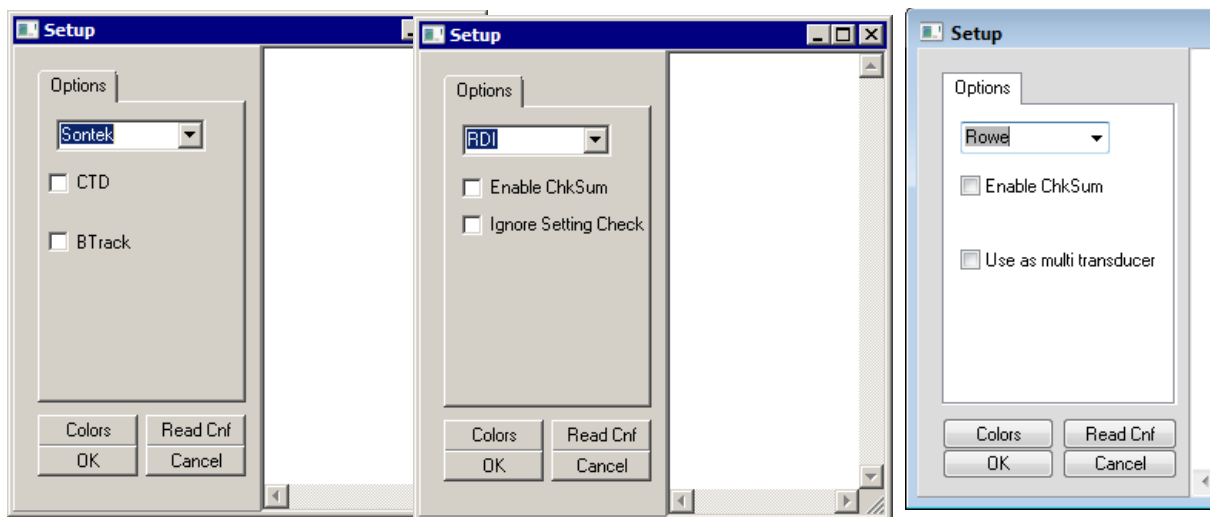

[Colors] accesses the standard HYPACK® Colors dialog.

[Read Cnf] reads and displays some of the options configured in the device itself.

SonTek Tab:

CTD: Logs conductivity, temperature and density in the SonTek format.

BTrace: Logs bottom tracking.

RDI Tab:

Enable ChkSum: Uses the checksum to verify data integrity in each record.

Ignore Setting Check: Check this option if you are using an RDI model other than the Workhorse. Other models use fewer settings, omitting some that are used in a validation process for the Workhorse.

DEVICE OUTPUT STRINGS

ADCP devices generally output in one of three formats:

- **ENU** (East, North, Up): RECOMMENDED. Speed along beams, corrected for pitch, roll and heading. (90% users use this option)
- **Boat Oriented** (stbd, fwd, up): Corrected for pitch and roll (not hdg). (2nd most commonly used)
- **Raw Beam Format:** Speed along beams, uncorrected. (rarely used)

DRIVER OUTPUT STRINGS

Logs HYPACK® *.ADP or *.000 (RDI format) ADCP data to the ADCP project folder.

DEVICE WINDOW:

Real-time display of current water velocity and direction at different depths, both in graphical and textual formats.

[Show Settings] enables you to access and modify the ADCP settings without leaving HYPACK® SURVEY

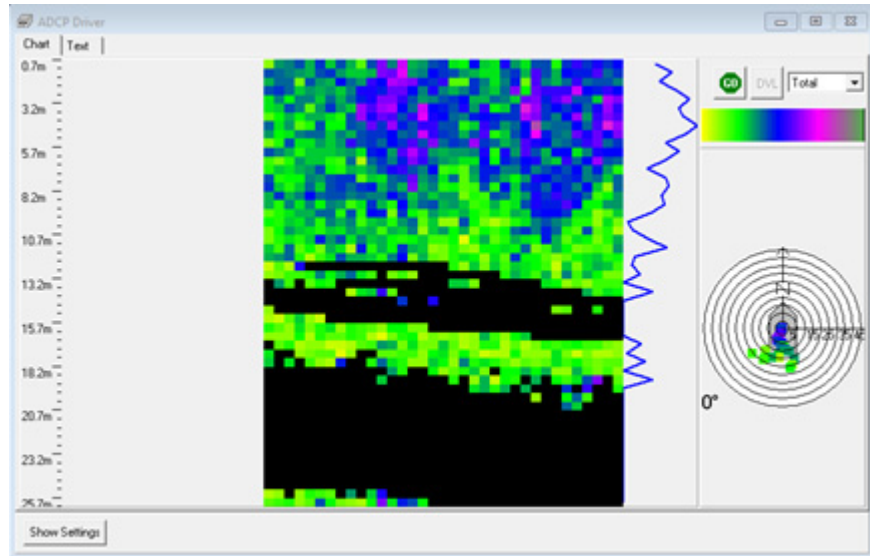
FIGURE 2. Sample Device Window

SERIAL PORT:

The Device window contains several options that you can change in SURVEY; you don't have to end logging and return to HARDWARE. It also includes a Go/Stop button.

- **When you click [Go]**, the driver sends the settings from the Device window to the device and begins logging.
- **When you click [Stop]**, the driver stops logging ADCP data, even though SURVEY may still be logging data from other drivers.

KNOWN SUPPORTED DEVICES

RDI Workhorse

SonTek ADP: firmware versions 5.0-7.1

SPECIAL NOTES

NORTEK DEVICES

Nortek devices supported by the ADCP In Situ program log their own data in the Nortek format. ADCP In Situ reads the Nortek format directly.

HEAVE, PITCH AND HEADING

At this time, HYPACK® does not have a way to correct ADCP data w/ pitch, roll and heading data from auxiliary devices (MRU, Gyro), primarily because there is no way to calibrate the rotation of the ADCP relative to the MRU and/or vessel. The best option, at this point, is to accept the pitch, roll, hdg data from the ADCP itself.

AIS.DLL

Version Number: 13.0.24

Device Name: AIS (Automated Identification Systems)

DEVICE SETUP

AIS Receiver (required)

DRIVER SETUP

CPA (Closest Point of Approach) distance alarm limit (nm) and **Time to CPA alarm limit:** Highlight vessels that could potentially become hazards. If the estimated trajectory of an AIS mobile comes closer to the estimated trajectory of own ship than the prescribed limit, the vessel in question is highlighted in the area map window. Estimated trajectories are constantly recalculated and the alarms are updated accordingly.

Hide vessels outside of (nm): The limit for displayed positions is significant only when you receive AIS updates over the Internet. There are a number of services like aishub.net or marinetraffic.com that provide AIS feeds over the Internet. If you are using one of these services, receiving position updates for 10 to 20 thousand ships might overload the computer. In most cases the default limit is high enough to cover updates received over the radio (typical VHF range is 30-50 miles).

Purge positions older than (days) and **Purge vessels older than (days)** control the retention period of the information in the database. The default values shown above should be adequate in most cases. However the database could be also used to implement some special reporting and, in that case, you might want longer retention periods

DEVICE OUTPUT STRINGS

Parses AIVDM messages received from an AIS receiver.

Interprets the AIS messages 1 and 5.

Recognizes Class B transceivers.

DRIVER OUTPUT STRINGS

The driver stores received messages into a database. It allows a rapid matching of positions to vessel information and also provides support for other tools to extract and plot that data. It is advantageous to quickly match positions with vessel name and voyage information because the vessel name is sent through a separate message (AIS message 5) less often than position information. Update frequencies of 1 to 5 minutes are typical for this information. In older versions, you had to have the survey program running for a few minutes before being able to see the vessel information. Now this is stored into a database and quickly searched whenever a new position report is received. Of course this scheme doesn't help in the case of a new vessel being picked up by the AIS, but this is not the most usual case.

HYPACK® SURVEY uses this data to display one symbol for each vessel in the Area Map display. Vessel symbols are displayed according to information from the AIS system and in compliance with IMO standards. This display includes rate of turn.

To activate/deactivate each vessel individually, right-click the vessel in SURVEY.

To view the AIS Mobile Name (if available) or the MMSI Number, hold the cursor over the mobile.

To view the AIS information on a mobile, right-click on it and select the Select option. The display in the Device window adjusts to display the selected vessel information.

SPECIAL NOTES

- No offsets required.
- **13.0.2.3:** The driver now stores received messages into a database. It allows a rapid matching of positions to vessel information and also provides support for other tools to extract and plot that data. It is advantageous to quickly match positions with vessel name and voyage information because the vessel name is sent through a separate message (AIS message 5) less often than position information. Update frequencies of 1 to 5 minutes are typical for this information.

In older versions, you had to have the SURVEY or DREDGEPACK® program running for a few minutes before being able to see the vessel information. Now this is stored into a database and quickly searched whenever a new position report is received. Of course this scheme doesn't help in the case of a new vessel being picked up by the AIS but this is not the most usual case.

AUTOLINES.DLL

Version Number: 17.0.0.0

Device Name: Auto Lines

Dynamically generates planned lines during acquisition.

DEVICE SETUP

Generate Output Messages: Generates messages or data outside of the Raw file.

In this case, it generates the planned lines.

DRIVER SETUP

FIGURE 1. Driver Setup

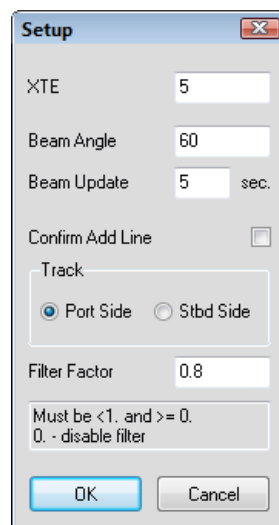

XTE: Driver ignores points less than the user-defined distance off line. The resulting line is smoother and has fewer waypoints. Enter the expected cross track error.

Beam Angle: Maximum angle of beams to use.

Beam Update: Frequency that the driver uses the current position to add a point to the new line.

Confirm Add Line: Only adds the line when you click [Add Line] in the Device Window in SURVEY.

Track: Choose **Port** or **Starboard Side**. The side of the vessel on which the new line is created.

Filter Factor: Strength to use when filtering width of beams.

Formula:

$$(EQ 1) \quad \text{new_val} = (\text{filter}-1)*\text{val} + \text{filter}*\text{prev_val}.$$

Filter = 1 uses the initial beam width.

CONNECTION SETTINGS

None. No device.

DEVICE OUTPUT STRINGS

None. No device.

DRIVER OUTPUT

Adds a new line to survey using previous path and beam positions.

DEVICE WINDOW

Provides controls for creating each line:

- **XTE:** Driver ignores points less than the user-defined distance off line. The resulting line is smoother and has fewer waypoints. Enter the expected cross track error.
- **Beam Angle:** Maximum angle of beams to use.
- **Confirm Add Line:** The driver only adds the line if you click [Add Line].
- **Track:** The side of the vessel on which the new line is created.
- **[Line Preview]:** Displays the new line in the Map window, before you create the line.
- **[Add Line]:** Generates the new planned line.

SPECIAL NOTES

AUTOPILOT.DLL

Outputs NMEA messages to the Autopilot which controls the vessel online. An update to the AutoP.DLL, the AutoPilot allows you to choose how aggressively the Autopilot steers to stay online. This driver was field tested on a boat with 600 feet of sonar cable in the water and held the vessel to within ~10 feet of the planned line for over a mile. It was repeated on several lines.

Version Number: 17.1.2

Device Name: AutoPilot

DEVICE SETUP

Generate Output Messages: Generates messages or data outside of the Raw file.

This driver generates the strings selected in the Setup dialog.

Record Raw Messages: Logs the data string to the raw file as it is originally received from the device.

This driver logs the NMEA string for the alarms.

DRIVER SETUP

FIGURE 1. Driver Setup

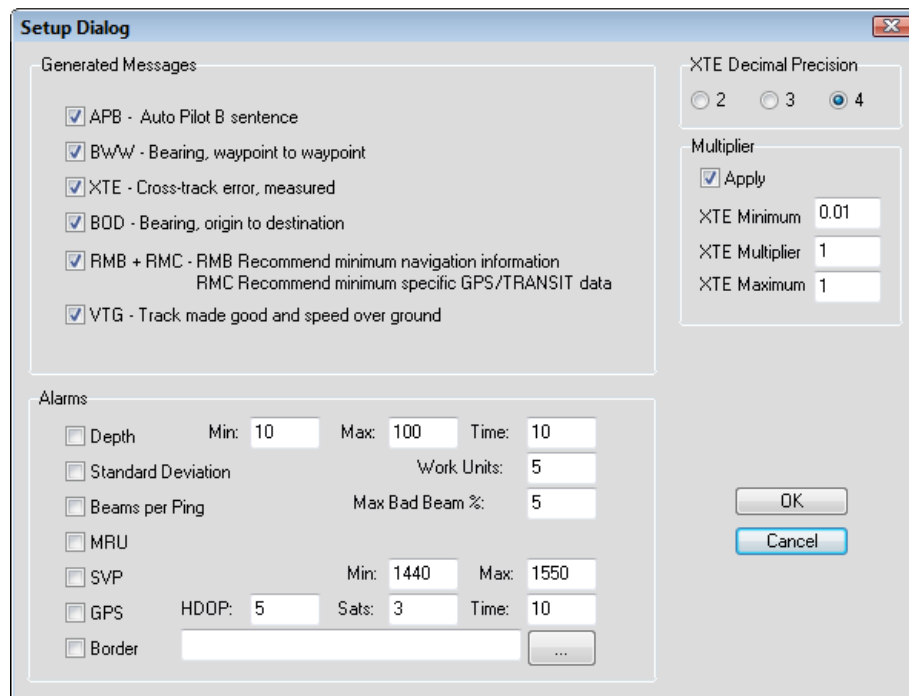

Sentences to Generate: Select your required output strings.

Decimal Precision: Select the number of decimal places required by your device.

Multipliers:

- **Apply:** Applies the multipliers to your device data.
- **XTE- Min./Max:** Scales the response slider which applies a multiplier to the cross track error value. This allows you to adjust the sensitivity of the driver.
- **XTE (Cross Track Error) Multiplier:** Most autopilots work in the Nautical Mile as a unit of distance and the minimum is 0.01 which equates to about 50 feet of accuracy. This means the autopilot wouldn't respond until the vessel was 50 feet off line and then it would make drastic turns to get on-line and cause a fishtail effect. The multiplier adjusts the signals sent out to the Autopilot. A typical multiplier would be in the 0.01-0.05 range.

Alarm Conditions:

- **Depth:** When the depth is outside of the range defined in the **Min** and **Max** options, or if a depth is not received in the specified Time (in seconds).
- **Standard Deviation:** When multibeam standard deviation is greater than specified standard deviation.

- **Beams per Ping:** When percentage of bad beams is greater than specified percentage.
- **MRU:** When MRU data is not received for over 15 seconds.
- **SVP:** When SVP data is out of range for over 10 seconds.
- **GPS:** When the HDOP is greater than defined in the HDOP field, the number of Satellites drops below the number specified in the Sats field, or if a position is not received in the specified Time.
- **Border:** When the vessel position is outside of the area defined by the specified border file (*.BRD).

You can also access driver configuration in SURVEY.

DEVICE OUTPUT STRINGS

None.

DRIVER OUTPUT STRINGS

NMEA strings specified in the Driver Setup. It records them to the Raw file, and sends them to the device.

Generated Messages:

- **\$GPAPB:** Auto Pilot B sentence
- **\$GPBWW:** Bearing, waypoint to waypoint
- **\$GPXTE:** Measured cross-track error
- **\$GPBOD:** Bearing of origin to destination
- **\$GPRMB:** Minimum navigation information
- **\$GPRMC:** Minimum specific GPS/TRANSIT data
- **\$GPVTG:** Track made good and speed over ground

Additionally, the driver reports the alarm states with a \$GPALR NMEA string:

Format	\$GPALR,t,xxx,A,B,c--c*hh<CR><LF>	
Where	\$GPALR	Tag
	t	Time (hhmmss.ss)
	xxx	ID number of alarm source
	A	Alarm condition = A; otherwise V
	B	Acknowledge state (unused)
	c--c	alarm description text

Format	\$GPALR,t,xxx,A,B,c--c*hh<CR><LF>	
	hh	Checksum
Sample string	\$GPALR,183923.29,203,A,,MRU bad data*0E	

DEVICE WINDOW:

FIGURE 2. Device Window

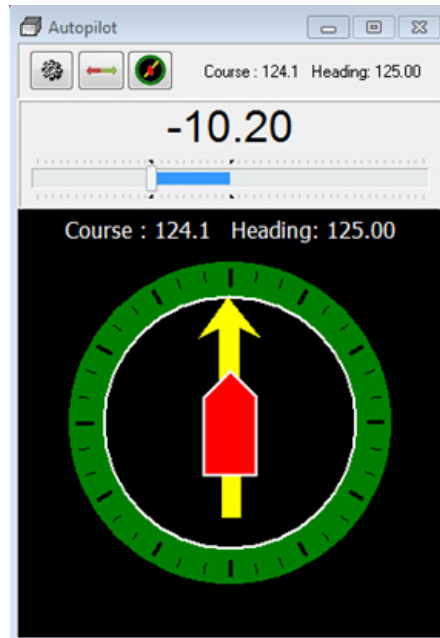

Choose from 2 displays using the icons in the toolbar:

- Left/Right Indicator
- Compass View

Access and adjust the setup and alarm options without leaving SURVEY. The Setup dialog also displays the generated messages in real time.

Use the slider in the setup options to adjust the signal multiplier for conditions on the water.

OUTPUT TO DEVICE:

NMEA messages selected in the Driver Setup:

- \$GPAPB
- \$GPBWW
- \$GPXTE
- \$GPBOD

- \$GPRMB
- \$GPRMC
- \$GPVTG
- \$GPALR

CONNECTION INFORMATION

Serial or UDP.

KNOWN SUPPORTED DEVICES

- SeaRobotics

CAPTURE.DLL

Version Number: 13.0.1.5

Device Name: Port Capture Device

DEVICE SETUP

Record device specific messages: Logs additional data related to the device to the Raw file. Each record will be identified by a driver-specific, 3-character tag.

This driver records the device output string defined by a CAP tag.

DRIVER SETUP

FIGURE 1. Driver Setup

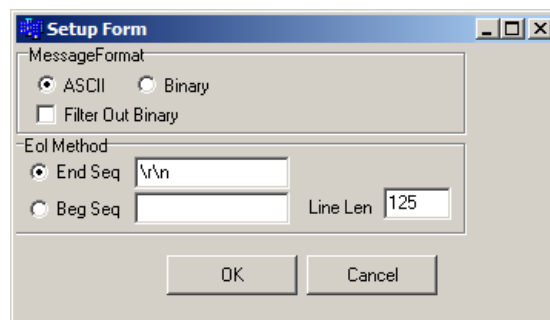

Message Format:

- **ASCII** or **Binary**: Tells the driver to expect ASCII or Binary input.
- **Filter Out Binary**: In ASCII mode, this option deletes anything that is not ASCII code 32-126.

EOL (End of Line) Method: Define the lines the driver should record using the following parameters:

- **End Sequence (End Seq)** captures all of the output, beginning each new record after the user defined character sequence.
- **Beginning of Sequence (Beg Seq)**: The program starts reading each line starting at the Beg Seq character string and reads until it either sees the same the character string again or reaches the **Line Len** (line length specified in number of characters) input.

DEVICE OUTPUT STRINGS

None specified. Reads the data from the device and saves to Raw file with a CAP ID tag.

DRIVER OUTPUT STRINGS

DEVICE WINDOW:

Writes line without the CAP tag.

SPECIAL NOTES

COVERAGE.DLL

The Coverage driver draws a series of contiguous polygons to a DIG chart file representing the area covered by your survey. This chart file is saved to your project folder.

Each time you start line, a colored swath draws to the Area Map according to the parameters in the Coverage Driver setup. Though you set these parameters initially in HARDWARE, the device window for the Coverage.dll in SURVEY enables you to modify your settings in real time during SURVEY.

Each time you end line, these swaths are saved in the project folder to a DIG chart file with the same root file name as the corresponding raw data file. The Area Map in SURVEY automatically displays each DIG chart.

Tip:

To minimize the number of files, you can periodically consolidate the DIG files into a DXF chart in the EXPORT program.

FIGURE 1. Coverage.dll Displays in the Area Map in SURVEY - Transparent Swath (left), Display Edges (right)

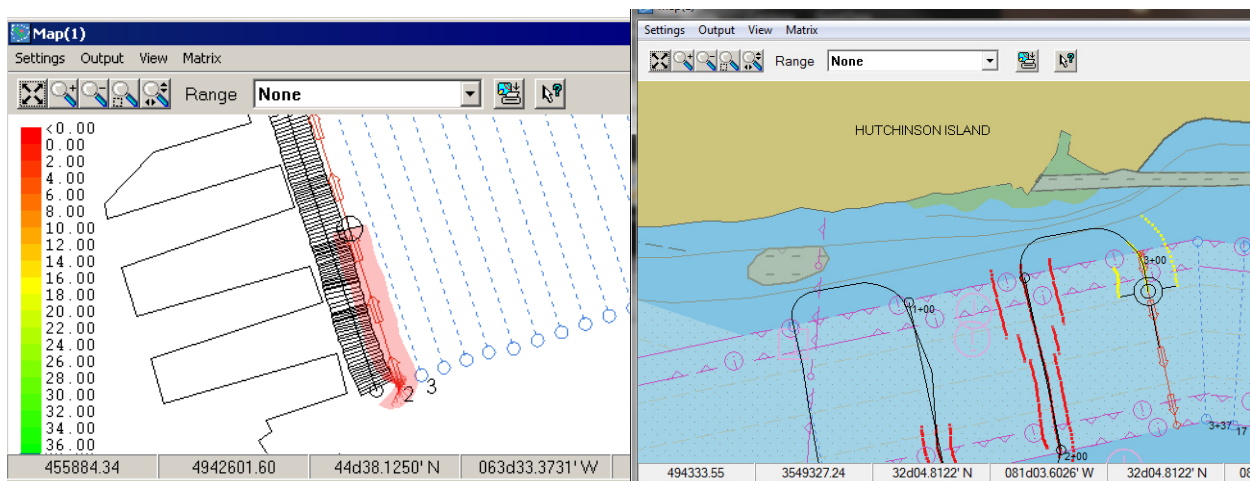

Version Number: 11.1.0.9

Device Name: HYPACK® Coverage Track

DEVICE SETUP

Generate Output Messages: Generates messages or data outside of the Raw file.

In this case, the driver generates the DIG charts. A rectangle centered on the vessel origin, as wide as the user-defined Swath

Width is generated for each position update where the vessel position has changed from the previous position record or at distance intervals defined in the Acceptance Gate option.

As with all drivers that generate output messages, the update frequency should be limited to 100 msec or more.

For this driver, a limit of 500 msec is sufficient in most cases and will further reduce screen flicker.

DRIVER SETUP

FIGURE 2. Coverage Driver Setup Dialog

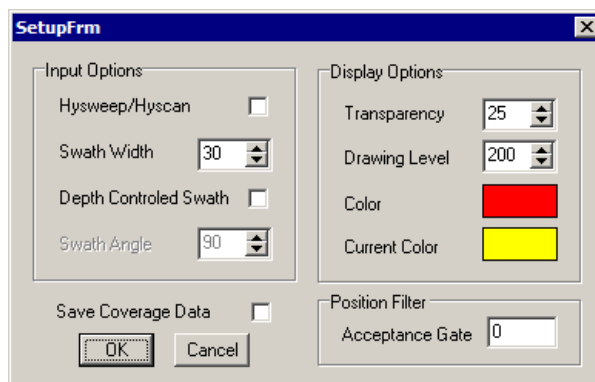

The **Input Options** determine the swath width drawn in the area map.

- **User-defined Swath Width:** Clear the Depth Controlled Swath option and enter a Swath Width. SIDE SCAN SURVEY draws polygons of user-defined width and centered on the vessel tracking point.
- **Calculated Swath Width:** Check the Depth Controlled Swath option and enter the Swath Angle. SIDE SCAN SURVEY draws the polygons based on depth information and the angle of your swath.
- **HYSWEEP® SURVEY/SIDE SCAN SURVEY:** The driver gets the swath width calculations from Shared Memory.

Current Color: Click in the color box and select a color for your current swath. When you end logging, the current color changes to the color defined with the **Color** option.

Transparency enables you to see features behind the swath (such as charts).

Tip:

If you set transparency to 50%, areas where you have achieved 200 percent coverage will show a blend of the overlapping swath colors.

Drawing Level allows you to adjust the draw order of the swath in the SIDE SCAN SURVEY display. (It is probably easier to accept the default and modify the draw order in SIDE SCAN SURVEY.)

Save Coverage Data stores the swath data for each line to a DIG chart file. The DIG files are named according to the line names and stored in the project folder.

Acceptance Gate determines the distance (in survey units) covered by each rectangle in the DIG (eg. a value of 10 tells the driver to generate rectangles 10 survey units x swath width). If the Acceptance Gate is '0', a new rectangle will begin at each position update. This provides the coverage information in DIG format without excessively covering other items drawn beneath it in the Area Map.

NOTE: Most of these options are available in the Coverage.dll Device Window in SURVEY.

Display Edges Only is only available in SURVEY. It changes the display from a solid, colored swath to outlines of the outer edges of the defined swath.

DEVICE OUTPUT STRINGS

None.

DRIVER OUTPUT STRINGS

Each time you end line, these swaths are saved in the project folder to a DIG chart file with the same root file name as the corresponding raw data file. The Area Map in SURVEY automatically displays each DIG chart.

SPECIAL NOTES:

As with all drivers that generate output messages, the update frequency should be limited 100 msec or more. For this driver, a limit of 500 msec is sufficient in most cases and will further reduce screen flicker.

DELPH.DLL

Version Number: 17.0.0

Device Name: NOAA Delph Output

DEVICE SETUP

Generate Output Messages: Generates messages or data outside of the Raw file.

(Required)

Paper Annotation: Annotates each event on the sounder's paper roll. (See Driver Output.)

DRIVER SETUP

None

DEVICE OUTPUT STRINGS

No device. Reads data stored in Shared Memory.

DRIVER OUTPUT STRINGS

DEVICE WINDOW AND SERIAL PORT

- **If logging:**

```
DD/MM/YYYY HH:MM:SS.SS LineName Event# MobileLat  
MobileLon BoatLat BoatLon MobileDepth WaterDepth  
CableLength MobileSpeed MobileSpeed MobileHeading  
LogStatus FileName <CR><LF>
```

- **If not logging:**

```
DD/MM/YYYY HH:MM:SS.ss LineName Event# MobileLat  
MobileLon BoatLat BoatLon MobileDepth WaterDepth  
CableLength MobileSpeed MobileSpeed MobileHeading  
0<CR><LF>
```

EVENTS

Start Logging: "START_LOGGING *FileName*<CR><LF>"

(If there's no FileName, prints same line without it.)

End Logging: "STOP_LOGGING<CR><LF>

Normal Events: The driver outputs a long string of space separated values as described below:

- Date (DD/MM/YYYY)
- Time (HH:MM:SS.SS)
- Line Name
- Event#
- Fish Latitude
- Fish Longitude
- Boat Latitude
- Boat Longitude
- Fish Depth
- Water Depth
- Cable Length
- Fish Speed
- Boat Speed
- Fish Heading
- Log Status (1=for logging, 0=not logging)
- FileName
- <CR><LF>

KNOWN SUPPORTED DEVICES

Triton Elics Delph system

SPECIAL NOTES

CableLength is read from Shared Memory. This part of shared memory is populated by the Towcable.dll associated with the mobile.

If Shared Memory has no cable out information, it reports the distance between the two mobiles.

EOL = <LF>

DIVER6.DLL

Version Number: 15.16.1.0

Device Name: Diver6

Reads network messages from the Diver6 tracking software and reports diver location to SURVEY.

DEVICE SETUP

Position: Logs position data from this device.

Depth: Logs soundings or magnetometer data from this device.

Use for matrix update: Color-codes a matrix based on the data received from this device.

DRIVER SETUP

FIGURE 1. Driver Setup

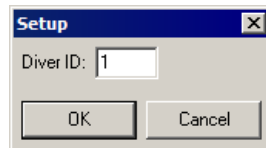

Diver ID: Set the diver ID to one of the divers you added in the Diver6 program.

NOTE: $\text{Diver ID}_{\text{HYPACK}} = \text{Diver Number}_{\text{Diver6}} - 1$
(eg. Diver #1: Diver ID=0).

DEVICE OUTPUT STRINGS

\$DIVER6, DiverNumber, DiverName, DirectRange, Azimuth, Depth, WaterTemperature, MaxDepth, Tank1Pressure, Tank2Pressure

DRIVER OUTPUT STRINGS

DEVICE WINDOW:

FIGURE 2. Sample Device Window

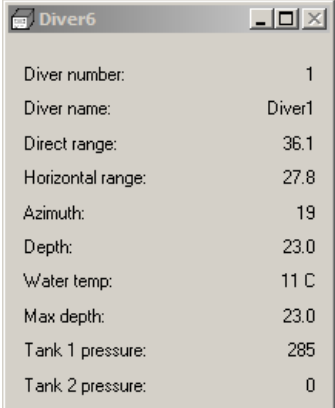

The screenshot shows a window titled "Diver6" with a list of diver parameters and their values:

Diver number:	1
Diver name:	Diver1
Direct range:	36.1
Horizontal range:	27.8
Azimuth:	19
Depth:	23.0
Water temp:	11 C
Max depth:	23.0
Tank 1 pressure:	285
Tank 2 pressure:	0

Displays the last received time in the status bar.

SPECIAL NOTES

Install one Dive6.dll / mobile.

The driver reads network messages from the Diver6 diver tracking software and reports diver location to SURVEY.

To set up Diver6 tracking software for testing:

1. Copy the Diver6 folder to C:\Program Files (x86)\
2. Copy diver6_doc to your documents folder, rename that folder to just diver6.
3. Run Diver6.exe from your program files folder
4. Choose Divemaster 1, password is "d1"
5. Choose "Configuration"
6. Choose "Data export"
7. Check "Broadcast Diver Data" and enter any address and port (I chose 224.0.0.2 and port 8001)
8. Click Back, then Back again
9. Choose Dive plan
10. Enter a value for "Max Depth" near the top right
11. Add a few divers from the list (ignore the warning message)
12. Click "Monitor Dive"

When you're in SURVEY, go to the Diver6 program, press "Shift+Z" to update diver positions. The position update should be reflected in SURVEY.

DRAFTTABLE.DLL

The Draft Table enables automatic updates of the draft values recorded in SURVEY that will be later used to correct the sounding depths.

Version Number: 13.0.10.11

Device Name: HYPACK® Draft Table

DEVICE SETUP

Draft: Logs draft data from this device.

DRIVER SETUP

FIGURE 1. DraftTable Driver Setup

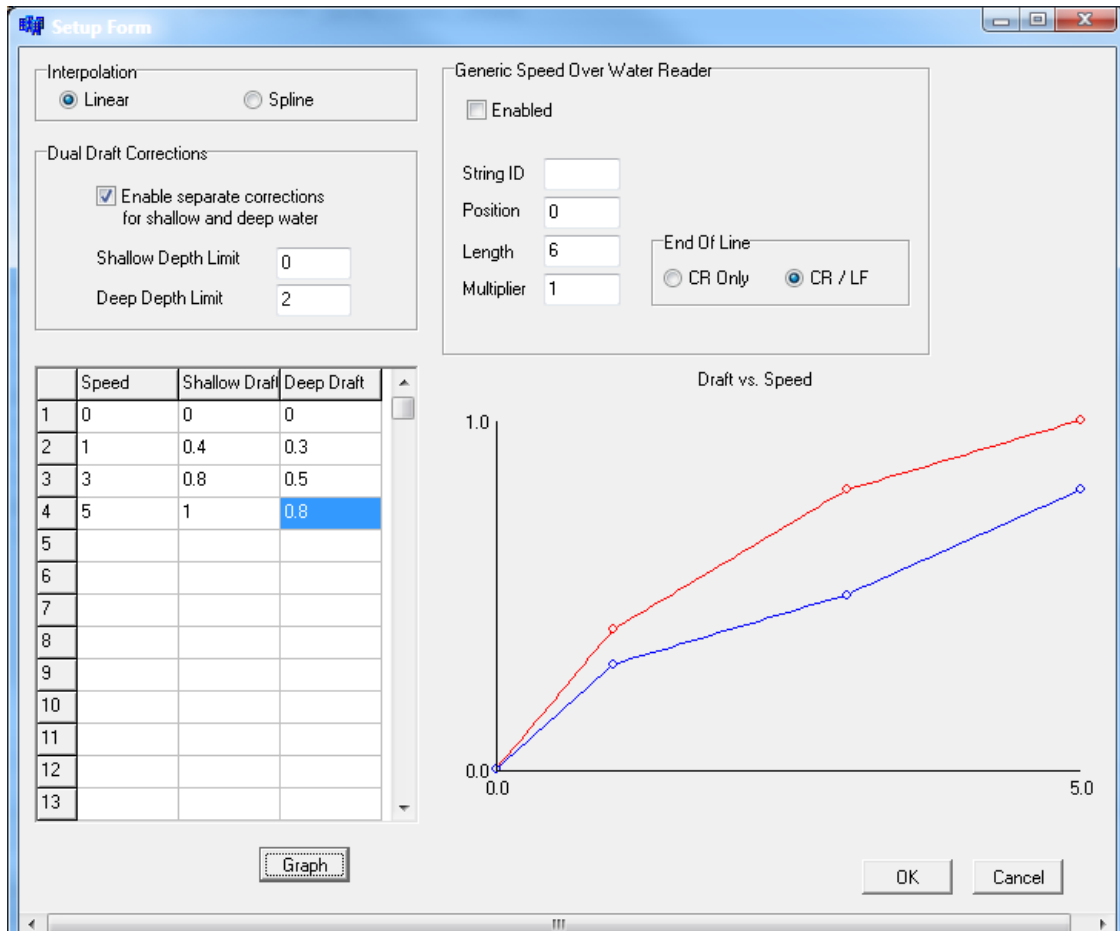

A table defines the draft values and their corresponding vessel speeds. SURVEY will use these values to store a draft correction value appropriate to the vessel speed with each sounding. It interpolates draft values according to the selected interpolation method and within the defined speed range.

Supports Shallow Water and Deep Water curves and interpolates when the depths are between the Shallow and Deep Depth Limits. Shallow depths can affect how the wake forms around the vessel and it has been shown that it can significantly affect the draft. If you are working in varying depths, enter different drafts for shallow and deep water.

- **If you enter both shallow water and deep water draft values:**
 - **When the depth is less than the shallow water definition,** the driver uses just the shallow water table.

- **When the depth is greater than the deep water definition**, the driver uses just the deep water table.
- **When the depth is between the shallow and deep water definitions**, the driver interpolates between the two table values.
- **If you only enter values in the shallow water column**, just use the shallow water values.
- **If you only enter values in the deep water column**, just use the deep water values.

NOTE: If there are soundings taken at speeds greater than those defined in the Draft Table, the driver will assign draft correction value that corresponds to the fastest speed in the draft table.

The graph options are used to configure the graph in the device window to suit your needs.

- **Shallow and Deep Depth Limits:** Determines the depth range where the draft corrections are interpolated based on the depth and speed. (For example, if the current depth in the middle of the specified depth range, the draft will be calculated as 1/2-way between the shallow and deep draft graphs.)
- **[Graph]** plots your corrections over speed on the right in the driver setup dialog. In SURVEY, the same graph appears in the device window with a pair of dotted lines indicating the draft and speed.
- **Generic Speed Over Water (SOW) Reader** options:
 - **Enabled:** Check if you are reading a speed log.
 - **String ID:** Start of line tag. The driver starts counting characters at the beginning of the tag.
 - **Position** character position in the string where speed is found.
 - **Length** defines length of speed value.
 - **Multiplier** default is 1. Multiplies value read. Driver “expects” that you are surveying in meters. If you are using another survey distance unit, you will need to use the multiplier to convert from meters.
 - **EOL** determines end of string.

DEVICE OUTPUT STRINGS

None. There is no device.

DRIVER OUTPUT STRINGS

DEVICE WINDOW:

Graphs the vessel speed (horizontal dotted line) and derives the draft based on the user-defined Shallow and Deep Depth Limits and the value of each sounding.

FIGURE 2. Sample DraftTable Device Window

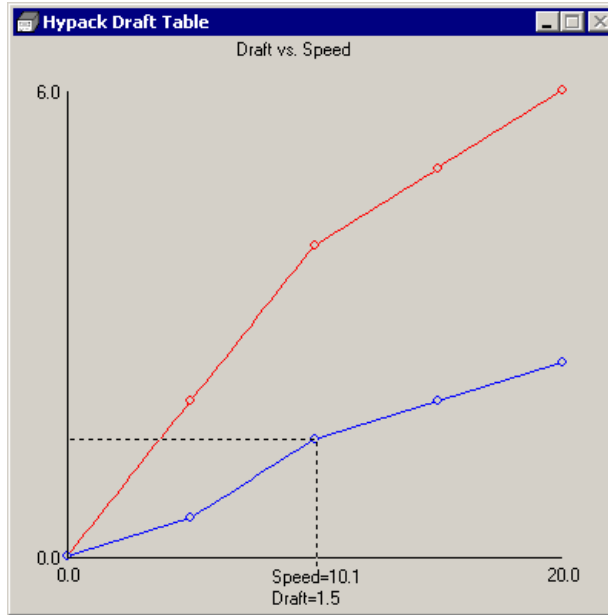

SPECIAL NOTES

- If you are surveying in a river surveying up and down the current, the drafttable.dll is not a good method to apply dynamic draft as your speed through the water column may differ drastically from your speed over ground.
- No connection settings are necessary.
- Displays draft to 2 decimal accuracy.

EELGRASS.DLL

Version Number: 16.1.0.

Device Name: Eelgrass Toggle Switch

DEVICE SETUP

Generate Output Messages: Generates messages or data outside of the Raw file.

This driver generates targets each time it receives a "\$PGRAS 1" message.

DRIVER SETUP

None

DEVICE OUTPUT STRINGS

\$PGRAS #

Where # is 0 or 1. If it's a 1, SURVEY marks a target.

DRIVER OUTPUT STRINGS

DEVICE WINDOW

The device window is configured in SURVEY from a tool bar in the device window.

FIGURE 1. Device Output Setup

Eel Grass Toggle Switch

Site Code

Transect

Select Items to be written to the output file

Time
 X
 Longitude
 Depth
 Sats
 Date
 Y
 Latitude
 HDOP
 Toggle State

Time	Date	X	Y	Latitude	Longitude	Depth	HDOP	Sats	Toggle State
03:36:37 PM	08/08/2016	0.00	0.00	34d14.6632'	073d39.0835'	0.00	0.00	0	0
03:36:37 PM	08/08/2016	0.00	0.00	34d14.6632'	073d39.0835'	0.00	0.00	0	0
03:36:37 PM	08/08/2016	0.00	0.00	34d14.6632'	073d39.0835'	0.00	0.00	0	0
03:36:37 PM	08/08/2016	0.00	0.00	34d14.6632'	073d39.0835'	0.00	0.00	0	0
03:36:37 PM	08/08/2016	0.00	0.00	34d14.6632'	073d39.0835'	0.00	0.00	0	0

[Save to File] exports the selected output items to a CSV (comma separated values) file.

The **Site Code** and **Transect** are the first two values in each record of an exported CSV file.

SPECIAL NOTES

GENDEVALL.DLL

Version Number: 9.0.4.8

Device Name: HYPACK® Generic Device Driver

DEVICE SETUP

Position: Logs position data from this device.

Depth: Logs soundings or magnetometer data from this device.

Heading: Logs heading data from this device.

Tide: Logs tide data from this device.

Heave: Logs heave, pitch and roll data from this device.

Use for matrix update: Color-codes a matrix based on the data received from this device.

Paper Annotation: Annotates each event on the sounder's paper roll. (See Driver Output.)

DRIVER SETUP

FIGURE 1. GenDevAll Driver Setup

Generic (Configurable) Device Driver Setup

Message Term
 CR LF
 CR/LF
 OTHER

Pos: 1234567890123456789012345678901234567890
 << 1 2 3 4 >>

	1st Char.	Last Char.	Multi-plier	Event Char.
Depth 1	0	0	1.0000	0
Depth 2	0	0	1.0000	
X	0	0	1.0000	
Y	0	0	1.0000	
Lat (D)	0	0	1.0000	
Lat (M)	0	0	1.0000	
Long (D)	0	0	1.0000	
Long (M)	0	0	1.0000	
Tide	0	0	1.0000	
Heading	0	0	1.0000	
Heave	0	0	1.0000	
Pitch	0	0	1.0000	
Roll	0	0	1.0000	

Buttons: Test, GetNextLine, Apply Changes, Exit

Position Filter

Min. Easting: 0.00 Min. Northing: 0.00
 Max. Easting: 0.00 Max. Northing: 0.00

Message Term.: EOL signal.

[Pos] click with cursor in the displayed string at the right and the dlg displays the character position in the string. (Personally, I think you'll be more accurate if you print a copy of the string and count the characters manually.)

[<<] and **[>>]** scroll the sample string through the display area.

First and Last Characters: position of each listed item in the device output string.

Multipliers: multiply the value read from the corresponding field. Default value is 1.0000.

Position Filter rejects all positions that don't fall within the range defined by the **Minimum and Maximum Easting and Northing**.

Event Char. character to be sent to trigger event mark.

[GetNextLine] displays next device input line across top of dlg..

[Test] after you define the 1st and last characters, test to display what is read from those positions in the sample string.

[Apply Changes] begins enabled, disables if you use it, enables if you click [Get Next Line].

DEVICE OUTPUT STRINGS

This is a generic driver, designed to accommodate any ASCII string.

DRIVER OUTPUT STRINGS

DEVICE WINDOW:

If **Depth** is selected, you specify start and end for at least 1 depth. When driver reads a new depth, formats it to 1 dec. and writes:

```
"Depth 1 = Depth1 "  
("Depth 1 = %0.1f "  
and  
"Depth 2 = Depth2"
```

If **Position** or **Heading** is selected, and you specify start and end for X or Y or Heading, formats values to 1 dec. and writes whatever it has:

```
"X=X Y=Y Heading = HeadingDegrees "  
"X=%0.1f Y=%0.1f Heading = %0.1f "
```

(Only writes label and value for values that it has.)

If **Tide** is selected and has tide data, formats to 1 dec. and writes:

```
"Tide = Tide"  
("Tide = %0.1f")
```

If **Heave** is selected and has heave, pitch and/or roll data, for whatever data it has read, it formats it to 1 dec., labels it and writes:

```
"Heave: Heave Pitch: Pitch Roll: Roll "  
("Heave: %0.11f Pitch: %0.11f Roll: %0.11f ")
```

SERIAL PORT

If **Annotation** is selected, outputs event character at user-defined position in the string followed by null.

SPECIAL NOTES

Driver Setup procedure:

After you do the [Connect] setup, click [Setup]. In the setup dialog:

1. Enter Line Termination option.
2. Click [GetNextLine].
3. Enter 1st char. and Last char. positions for each item you want to read from the input string.

4. Click [Apply Changes] then [Test]. The driver will read the values from the string according to the character positions entered and display them in the dialog.
5. If the values are *not* correct, change the character position information then apply and test again.
6. If the values are correct, click [Exit].

Errors:

Cause	Error Message
1 st or last char. contains a space.	"The selected range is not a legal number,i.e, it contains spaces ","space between numerals"
1 st or last char contains a space or some other non-numeric char.	"The selected range is not a legal number,i.e, it contains characters like spaces, comma etc. ","Error - Selected Range Not A Legal Number"
Last position comes before the 1 st	"The '1st char.' is greater than 'Last Char.', which is illogical. ","Error - 1st Char. > Last Char."
Character ranges overlap	"The '1 st char.' of some variable falls in between the '1 st Char.' & 'Last Char.' of some other variable."
If Event Char. < 0	"Value typed in is negative","Error - Negative value entered"
If Event Char specified when no Depth positions were defined.	"Event Char. can't have a value when other Depth1 values are zero","Error - Non-zero value entered when other values are zero"
If a Multiplier is specified when no Depth positions are defined	"1st Char. and Last Char. being zero, the multiplier cannot have a value","Error - Non-zero value entered when other values are zero"
If negative value entered as Depth position.	"Value typed in is negative","Error - Negative value entered"

Cause	Error Message
If Depth position is greater than the length of the string read.	"Value typed in is greater than the buffer length", "Error - Value > Buffer Length"
If 1 st or last char. is a legal value, but the other is zero.	"Either the 1st char. or Last Char. is zero, one of them being a legal integer.", "Error - One value is zero error"

GENDEVPARSE.DLL

VERSION NUMBER

15.5.0.2

DEVICE NAME

Generic Device Parser

DEVICE SETUP

This driver can read most ASCII strings. Select the types of data that you want to view.

Position: Logs position data from this device.

Depth: Logs soundings or magnetometer data from this device.

Heading: Logs heading data from this device.

Speed: Displays speed data from this device.

Heave: Logs heave, pitch and roll data from this device.

Tide: Logs tide data from this device.

Draft: Logs draft data from this device.

Use for matrix update: Color-codes a matrix based on the data received from this device.

Record device specific messages: Logs additional data related to the device to the Raw file. Each record will be identified by a driver-specific, 3-character tag.

DRIVER SETUP

FIGURE 1. GenDevParse Driver Setup

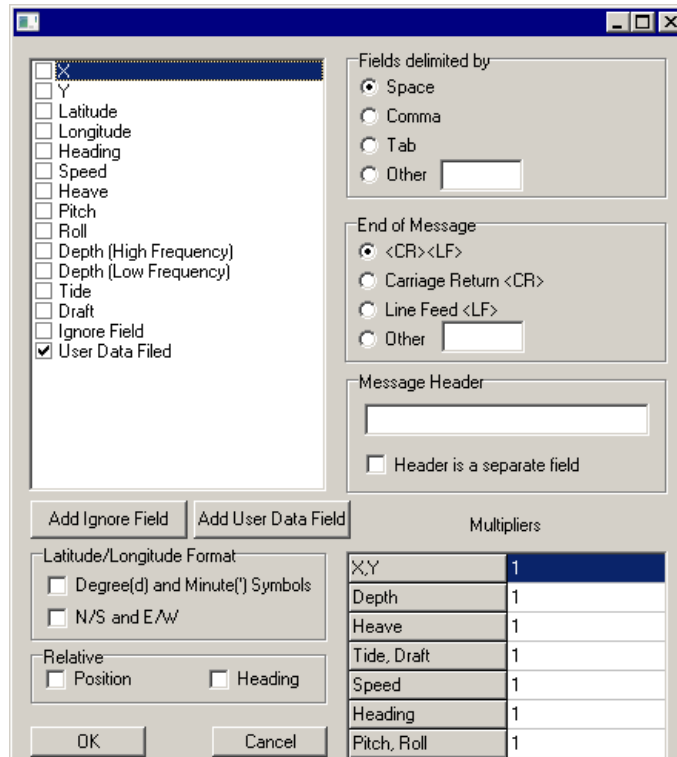

- On the left, select Driver Output items.
There must be a checked item for each item in the data string, in the order that it appears in the string. (You can click and drag the items in the list to reorder them.) If the string has data that you do not wish to view, select "Ignore Field".
 - **[Add Ignore Field]** will create additional "Ignore Field" selections if you need them.
 - **[Add User Data Field]** creates additional "User Data Fields" if you need them. User Data Fields are stored in a UDT record in the raw data.
 - **Latitude/Longitude Format:** Check if latitude and longitude are written with "d" for degrees and "" for minutes.
 - **Relative:** Check if the position or heading are relative to another mobile. Specify the mobile in the Advanced of Hardware under "Position relative to".
- On the right, define for the driver what to expect in the format of the incoming data string.
 - **Message Header** is the leading tag that begins each output string to be read. This enables the driver to select one

string type from multiple output string types of the same device.

- **End of Message** Indicate what designates the end of a device output string.
- **Multipliers:** Check the units in which your device is measuring each value and, if necessary, enter a multiplier to convert the value to HYPACK units as follows:
 - **X,Y:** Horizontal survey units
 - **Depth, Heave, Tide, Draft:** Vertical survey units
 - **Speed:** Horizontal survey units per second
 - **Heading:** Radians
 - **Pitch, Roll:** Degrees

DEVICE OUTPUT STRINGS

Must output the items that you chose and in whatever field order is described in your Driver Setup.

FIGURE 2. Sample Displays in SURVEY

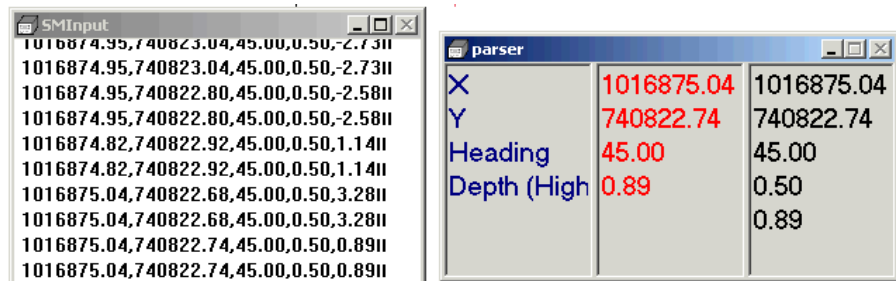

DRIVER OUTPUT STRINGS

DEVICE WINDOW:

On the left of Figure 2, shows a scrolling display of the data strings that the GenDevParse.dll is reading. On the right, we see a sample Device Window generated by GenDevParse. The first two columns show the items that you selected to display from the data string. The right-most column displays all data that is being read.

Note that the device output string contains one more value than has been selected for display.

SPECIAL NOTES

GENEVENT.DLL

Version Number: 9.0.2

Device Name: Generic Event Driver

DEVICE SETUP

Paper Annotation: Annotates each event on the sounder's paper roll. (See Driver Output.)

Generate Output Messages: Generates messages or data outside of the Raw file.

GenEvent outputs the annotation text.

DRIVER SETUP

FIGURE 1. Driver Setup

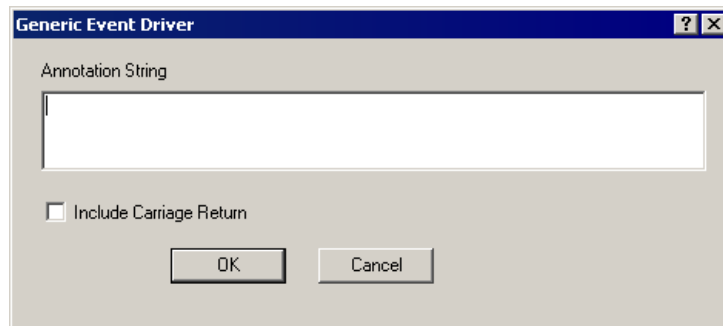

In the **Annotation String** box you have to write a template for your annotation. Everything that doesn't start with a '%' sign will be included in the annotation string. The "%..." sequences are replaced by numerical values.

Values you may display (only the most important ones – for the full list read on):

- %E – event number
- %L – line name
- %H – time
- %D – date
- %Z – depth

For example:

Annotation Definition	Sample Output...
Line %L Event %E Depth %Z	Line 00+50 Event 23 Depth 12.53

NOTE: Though the driver allows you to output almost anything, it does you no good if it is in a form your sounder cannot read. Check the echosounder manual and format your string to match what the manual says.

For example: For instance the BATHY1500 annotation string has to start with "\$GPANN," end with a <CR><LF> sequence and the annotation text must be included in quotation marks.

NON-PRINTING CHARACTERS:

Some sounders require characters that are not available on your keyboard. In this case, you must define them using the hex sequence which begins "\x" and is followed by the 2-digit code that defines the character.

For example: For a Bathy500, you need to start your annotation with two characters, the first one has the hex code 06 and the second one has a hex code 01. At the end of the annotation, you need to send a character with the hex code 04. You would then modify the above example as follows:

Annotation Definition	Sample Output...
\x0601Line %L Event %E Depth %Z\x04	Line 00+50 Event 23 Depth 12.53

FORMATTING NUMERICAL VALUES

You can control the width of each numeric field as well as the number of decimal places.

For example: Writing something like "%5.1Z" will allocate five characters for the depth value and will print it with one decimal. The default is 2 decimals for all fields that can have decimals.

DEVICE OUTPUT STRINGS

None

DRIVER OUTPUT STRINGS

User-defined in the Driver Setup.

SPECIAL NOTES:

- Use the same port setting for your echosounder.
- Omit the “Paper Annotation” option in your sounder’s setup as it is already covered by the GenEvent driver.
- Requires the genev.db (in the HYPACK® install folder) which lists supported devices. (Shared w/ other drivers. (eg stasto.dll.))

FORMAT CODES

Display Item	Required Code
X-position	%[l].[p]X
Y-position	%[l].[p]Y
Heading	%[l].[p]H
High freq. Depth	%[l].[p]Z
Low freq. Depth	%[l].[p]z
Time (hh:mm:ss)	%h
Date (mm-dd-yyyy)	%D
Event number	%[l].[p]E
Filename (with path)	%[l]F
Filename (without path)	%[l]f
Tide	%[l].[p]T
Event type ('s', 'e', 'm', ' ')	%e
Line name	%L
Line number	%l
Line azimuth	%[l].[p]A
Line segment	%S

In the above list [l] represents an optional file length specifier and [p] an optional precision (number of decimals) specifier.

GENLASER.DLL

Version Number: 9.0.1.0

Device Name: Generic Laser Device

DEVICE SETUP

Generate Output Messages: Generates messages or data outside of the Raw file.

This driver outputs the messages configured in the Driver Setup.

DRIVER SETUP

None. Configure the device to output the required Device Output sentences listed below.

DEVICE OUTPUT STRINGS

- Laser Atlanta's \$LA1KA string.
- Laser Technologies Criterion Series \$PLTIT string

DRIVER OUTPUT STRINGS

This driver will mark a target at the bearing and distance read from the device offset from the vessel's position.

SPECIAL NOTES

CONNECTION INFORMATION

- **Serial Connections:** 4800,N,8,1
- **Bluetooth:** Although the Bluetooth connection should work, it involves setting up the network parameters correctly

LASER ATLANTA DEVICE SETUP

To get Laser Atlanta's \$LA1KA message, use the menu sequence BBAB on that device.

HYSWEEP.DLL

Version Number: 12.0.2.8

Device Name: HYSWEEP® Interface

DEVICE SETUP

Depth: Logs soundings or magnetometer data from this device.

Heading: Logs heading data from this device.

Speed: Displays speed data from this device.

Use for matrix update: Color-codes a matrix based on the data received from this device.

This option is no longer necessary. The matrix is painted based on data in Shared Memory.

DRIVER SETUP

None

DEVICE OUTPUT STRINGS

None. Passes data between HYSWEEP® SURVEY or SIDE SCAN SURVEY and HYPACK® SURVEY.

DRIVER OUTPUT STRINGS

DEVICE WINDOW:

none

SERIAL PORT:

none

SPECIAL NOTES

The only time you need the Hysweep.dll is if you want to pass nadir depth, heading or motion from HYSWEEP® SURVEY or SIDE SCAN SURVEY to HYPACK® SURVEY. It does nothing for matrix painting anymore. It's mostly to display that data in the Data Display window.

HYSWEEP_PLAYBACK.DLL

Reads MB1 records in raw multibeam data files (*.HSX) and uses the data to replicate the multibeam survey in HYPACK® SURVEY and HYSWEEP® SURVEY together. If you log data during the simulation, the files you log will be the same as the files you are reading.

Version Number: 14.0.1.8

Device Name: HYSWEEP Playback

DEVICE SETUP

Position: Reads and logs position data from this driver.

Heading: Reads and logs heading data from this driver.

DRIVER SETUP

None

DEVICE OUTPUT STRINGS

None. Data read from Multibeam HSX

DRIVER OUTPUT STRINGS

DEVICE WINDOW:

Displays vessel X, Y and Heading as the simulation progresses.

FIGURE 1. Sample Device Window

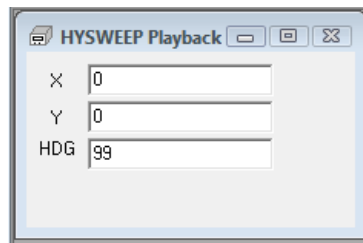

SPECIAL NOTES

Configuring the Simulation in HARDWARE

1. **Click on 'Boat'.**
2. **Select 'HYSWEEP Playback'** from the Survey Devices list.
3. **Click [Add].**
4. **Select the Position and Heading functions.**

There are no setup parameters, as it will be reading everything from the HSX file.

5. **Select 'HYPACK Configuration' and select 'Include' under HYSWEEP® SURVEY.**
6. **Select 'HYSWEEP® SURVEY'.**
7. **Select 'Simulation (Playback)' from the Manufacturer/ Model list and click [Add].**
8. **Click [Setup...].** The Simulation Setup window appears.
9. **Click [...] and navigate to the Raw folder containing the *.HSX files that you want to playback in the simulation.** The folder can be the Raw folder within your current project, the Raw folder in another project, or a specific folder somewhere else on your computer, or network. You may play an individual HSX file or a catalog (*.LOG) of HSX files.
10. **Select the *.LOG or *.HSX file to use in the simulation and click [Open].**
11. **Verify the path and file selected, and click [OK].**
12. **Save your hardware settings and close the HARDWARE program.**

You can now open HYPACK® SURVEY and HYSWEEP® SURVEY to view your simulation.

LCD3.DLL

Version Number: 9.0.1.3

Device Name: Parallel Helmsman Display

DEVICE SETUP

Generate Output Messages: Generates messages or data outside of the Raw file.

(Required) This driver outputs the data requested in the driver setup through the parallel port.

DRIVER SETUP

FIGURE 1. Driver Setup

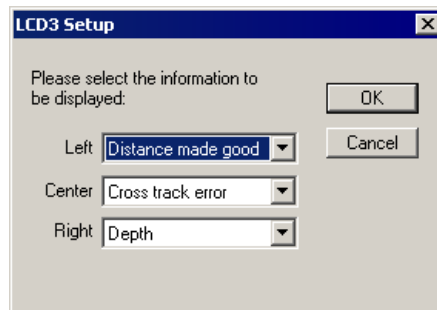

Two choices are available for each display field on the helmsman device.

Left: DMG (Distance Made Good) or Distance To Go

Center: XTE (Cross Track Error) or DMG (Distance Made Good)

Right: Depth or Line Number

DEVICE OUTPUT STRINGS

Acknowledges each time data is sent to the device by the driver. This triggers another response from the driver (see Driver Output Strings).

DRIVER OUTPUT STRINGS

12 character string to LPT port with data requested in the driver setup. String sent out LPT port backward, then reversed and written to device window.

Responds to device's "acknowledgement" signal through LPT port+2. The driver's response depends on the content of the device's acknowledgment.

Acknowledgement	Response
1	0
0	1

SPECIAL NOTES

"Bad Port" error: This device can be connected only to LPT1 or LPT2.

Code exists to calculate many more choices than what appears in the driver setup. Additional choices currently not implemented include:

- Line Segment
- Event #
- Line Azimuth
- Bearing of mobile
- Speed
- Heading
- XTE times 10
- Speed time 10

LCD4.DLL

Version Number: 9.0.1.2

Device Name: Serial Helmsman Display

DEVICE SETUP

Generate Output Messages: Generates messages or data outside of the Raw file.

REQUIRED

DRIVER SETUP

Reverse XTE: A jumper inside the box controls the direction of the reported cross-track error (XTE). This option changes XTE direction without changing the jumper inside the box.

DEVICE OUTPUT STRINGS

None.

DRIVER OUTPUT STRINGS

Outputs 4 lines of data:

1. "1Time: *Time* Date: *Date* Line *LineNumber*<CR><LF>"
("1Time: %s Date: %s Line %i\r\n")
2. Formats mobile DTG to 1 dec, Line Azimuth to nearest integer and Depth to 2 dec and writes:
"2DTG:*MobileDTG* Line az.: *LineAzimuth* Depth:*Depth*"
("2DTG:%6.1f Line az.: %3.0f Depth:%6.2f")
3. Formats speed and XTE to 1 dec. and Scale to integer and writes:
"3SPD:%4.1f XTE:%5.1f Scale:%3.0f"
("3SPD:%4.1f XTE:%5.1f Scale:%3.0f")
4. Creates electronic L/R indicator. Indicates XTE with "----- on either side of center (marked by ◦). If XTE exceeds the range of the display, the end of the line will show a < or > on the end of the dashes to indicate that.

LINEOFFSET.DLL

Version Number: 17.1.0

Device Name: LineOffset

The Line Offset driver is used to generate parallel lines at a user-determined offset during a survey. The driver is similar to the AutoLines driver, but instead of the driver determining the line offset, the surveyor is allowed to make the choice.

The Line Offset driver works under specific conditions:

- It requires a planned line file (*.LNW) that contains one, single-segment line that will be used as a base line.
- This LNW must be the only LNW selected in the HYPACK® Project Items list.
- The planned line (LNW) is also loaded into SURVEY, which happens automatically as it is enabled in the Project Items.

The driver generates an offset line when a vessel successfully traverses a line or when logging is stopped. Lines are generated such that a rectangle could always be formed by connecting the offset lines. That is, if perpendicular lines were drawn on the top and bottom points of the original line, all offset lines would be parallel to the original line and end at the perpendicular lines that were just drawn. (The lines are drawn on the normal of the original line.)

The generated lines are stored in the base line LNW file.

DEVICE SETUP

None.

DRIVER SETUP

None.

CONNECTION SETTINGS

None

DEVICE OUTPUT STRINGS

None

DRIVER OUTPUT

Additional survey lines offset by a user-defined amount and direction starting from the original base line.

DEVICE WINDOW:

The **offset distance** (in survey units) is determined in the text box in the middle of the driver window and it can be changed at any time.

The **direction of the offset line** is determined by the direction buttons surrounding the text box. The lines are drawn parallel to the original base line (LNW); thus the line is only ever offset in one of two directions, left or right to the original line. Because left or right could mean left or right of the vessel or left or right of the line, the Line Offset driver uses cardinal directions in the Device window to determine which way the offset line is placed:

- Either **North** or **East** would generate a line to the northeast of the original line.
- Either **South** or **West** would generate a line to the south-west of the original line.

SPECIAL NOTES

LPT EVT.DLL

Version Number: 9.0.1.1

Device Name: HYPACK® Event Mark Generator

DEVICE SETUP

Generate Output Messages: Generates messages or data outside of the Raw file.

Paper Annotation: Annotates each event on the sounder's paper roll. (See Driver Output.)

DRIVER SETUP

FIGURE 1. Driver Setup

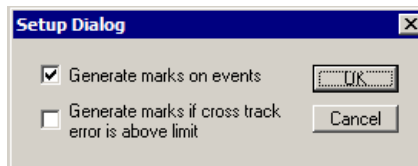

Define when events should be generated.

Generate marks on events.

Generate marks if cross track error is above limit: Generates 1 mark when boat passes cross track limit set in Survey's navigation parameters.

DEVICE OUTPUT STRINGS

None.

DRIVER OUTPUT STRINGS

DEVICE WINDOW:

- **If you are marking events**, on event writes “Event”, marks event then writes “Mark”.
- **When the boat passes the XTE limit and you are generating marks** when this occurs, writes “XTE”, marks event then writes “Mark”.

SERIAL PORT:

Sends 0xff, waits 100msec and sends 0x0.

SPECIAL NOTES

KNOWN SUPPORTED DEVICES

Serial and USB-to-Serial Event boxes.

ERROR MESSAGES

TABLE 1. Error Messages

Cause	Message
Device port connection setting is not LPT1: or LPT2	"This device can be connected only to LPT1 or LPT2"
Initialization of driver with device fails	"Can not open Smpport"

SETTING THE DWELL DELAY

The dwell delay is the time that the relay contacts remain closed when an event has been triggered. The dwell delay may need to be changed to suit the type of instrument that is attached to it. For a fast updating echo sounder in shallow water a short contact closure will be sufficient to make the echo sounder. On the other hand a seismic or sub-bottom profiler running in deep water will require a much longer contact closure. The length of the delay is generated by a digital timer inside the microprocessor and set by the position of 4 jumpers located inside the Event Interface. The 4 jumpers are configured as a BCD counter with each count corresponding to a delay value of 200mS or 0.2 Seconds.

FIGURE 2. Device Diagram

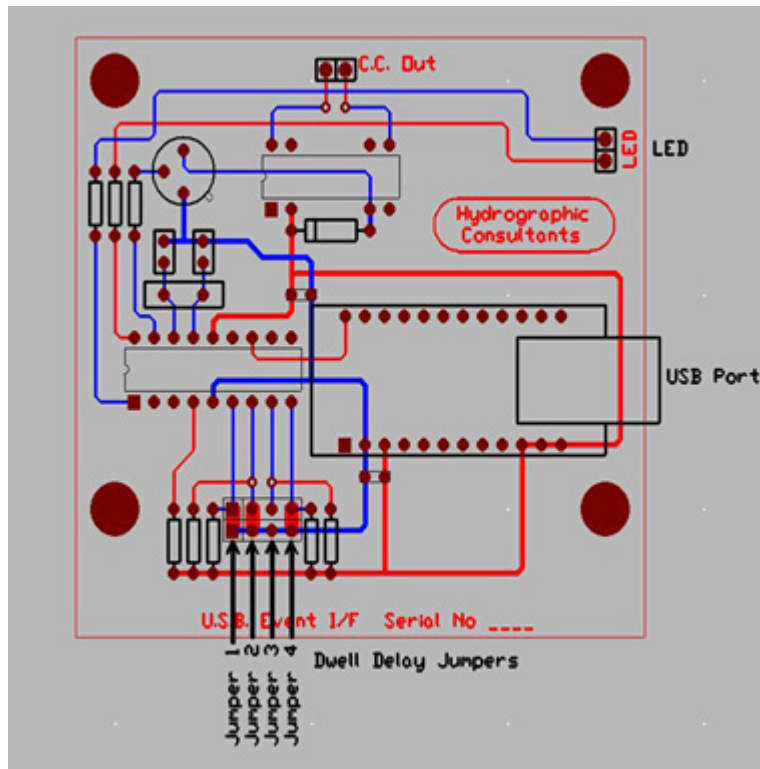

TABLE 2. Jumper Setting to Dwell Delay

Delay	J1	J2	J3	J4
20 mS	X	X	X	X
200 mS	-	X	X	X
400 mS	X	-	X	X
600 mS (default)	-	-	X	X
800 mS	X	X	-	X
1.0 sec	-	X	-	X
1.2 sec	X	-	-	X
1.4 sec	-	-	-	X
1.6 sec	X	X	X	-
1.8 sec	-	X	X	-
2.0 sec	X	-	X	-
2.2 sec	-	-	X	-
2.4 sec	X	X	-	-
2.6 sec	-	X	-	-
2.8 sec	X	-	-	-
3.0 sec	-	-	-	-

X indicates link in place - indicates link removed There are no other operator controls or settings. The contact closure output are isolated relay contacts with no connection to the USB port or host computer.

TROUBLESHOOTING

In the case of problems it is useful to inspect the Windows Device Manager settings.

1. Click - Start – Control Panel
2. Click - System then select the Hardware Tab at the top of the page.
3. Click - The Device Manager Icon
4. Click - The + sign next to (Ports & LPT) to expand the menu.
5. Double Click - USB Serial Port (Com?)
6. Click - The Port Settings Tab at the top of the page
7. Click - The Advanced button
8. Change - The Com Port Number to the required port number.

Often the USB / Com Port number can change in Windows if an additional USB device is added, if the USB Event Interface will not trigger, go back and check the settings using the above procedure.

NOTE: The virtual com port drivers used with the USB Event Interface are identical to those used with the USB Helmsman Display and are interchangeable.

SERIAL SENDER

A simple, troubleshooting program allows you to check the operation of the USB Event Interface without the need to run a Navigation Program.

To Run Serial Sender (supplied on the CD)

1. Select 9600 baud and the Com Port to which the USB Event Interface is connected.
2. Type EVENT into the text box and press SEND. The sentence EVENT<cr><lf> is sent to the appropriate com. port and the USB Event Interface should trigger (the Green LED will change to Red and the relay will energize).

LRIND.DLL

Version Number: 14.0.11.1

Device Name: LR Indication

DEVICE SETUP

Generate Output Messages: Generates messages or data outside of the Raw file.

DRIVER SETUP

None.

DEVICE OUTPUT STRINGS

None. No device.

DRIVER OUTPUT STRINGS

DEVICE WINDOW:

Another left/right indicator specific for the mobile to which it is assigned.

FIGURE 1. Sample Device Window

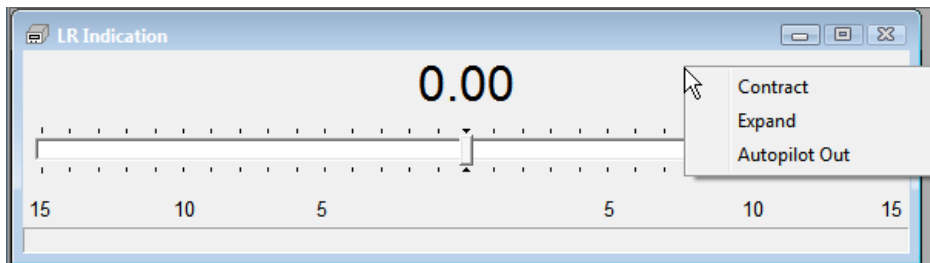

SPECIAL NOTES

To contract or expand the scale right-click on the driver and select the option you want.

KP.DLL

Version Number: 11.1.1.1

Device Name: KP Shared Memory Output

DEVICE SETUP

Generate Output Messages: Generates messages or data outside of the Raw file.

DRIVER SETUP

None.

DEVICE OUTPUT STRINGS

None. No device.

DRIVER OUTPUT STRINGS

DEVICE WINDOW:

Displays Kilometer Point (distance along line in km) in real time.

SPECIAL NOTES

EXPORT PROGRAM

KP Options: Select the 'KP' export item, you must enter the information in the KP Options section. For each sounding in an XYZ or All format file, the KP item exports the distance from the beginning or end of a user-defined center line.

- **Center Line File:** The line file (*.LNW) defining the center line. It should contain only the center line.
- **Offset:** The distance either side of the defined center line where EXPORT should include.

- **Start with Last Point:** Select this option to export distance from the *end* of the center line.
- **Kilometers:** The default unit of measure is meters. Check this option to output kilometers instead.

The program will take the selected information from each record in the Input file and send it to the specified Output file. Lat/Lon formatting is determined by your settings in the HYPACK® Control Panel.

M3.DLL

Version Number: 16.0.0.1

Device Name: Kongsberg M3

DEVICE SETUP

Generate Output Messages: Generates messages or data outside of the Raw file.

This driver generates an automosaic of the side scan data when you close HYPACK® SURVEY.

DRIVER SETUP

FIGURE 1. Driver Setup

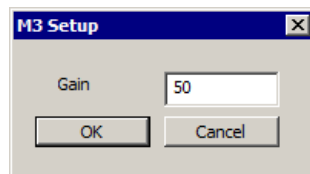

Gain: Affects brightness. Default = 50

DEVICE OUTPUT STRINGS

Side scan data.

DRIVER OUTPUT

DEVICE WINDOW:

The Device window in HYPACK® SURVEY shows the real-time imaging, and allows you to change the gain, or connect/disconnect the data flow.

SIDE SCAN SURVEY

In SIDE SCAN SURVEY, select the CHART-SIDE SCAN menu item to activate the Side Scan Settings dialog where you can enable the side scan and select the appropriate cell size. Additionally, you can select the update mode and mosaic transparency.

FIGURE 2. SS Survey Settings

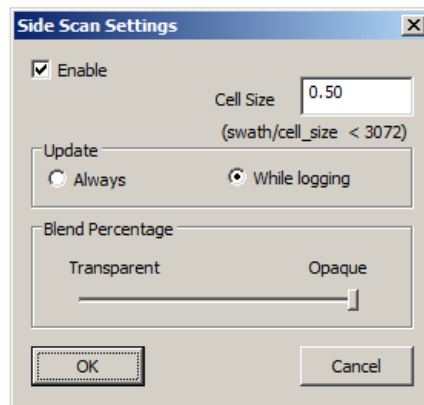

- **Cell Size** determines the resolution of the mosaic. A smaller pixel size increases the resolution, as well as the file size of the finished mosaic.
- **Update**
- **Blend Percentage Slider:** Affects the blending based on the relative weights of overlapping data. Once each value in each swath is weighted by your style option, the program compares the weights of the overlapping data. Logically, if the overlapping data is weighted equally, you would want both sets reflected in the blend. If, however, the data is weighted very differently, you would want the program to use the better data.
 - **With the slider far to the right**, blending will almost always occur, even though their weighting is quite different.
 - **With the slider far to the left**, the program will usually present the data from the data set with the greater weight.
 - **With the slider at a mid-range position**, the two methods are combined.

SPECIAL NOTES

- The M3 must be connected to port 20001 using TCP network protocol.

MVP.DLL

ODOM MVP Sound Velocity Profiler: MVP (Moving Vessel Profiler) has the ability to track sound velocity values over a range of depths. The HYPACK® driver displays sound velocity vs. depth profiles and records the data to HYPACK® sound velocity files. The driver will also feed the device with navigation data through a serial port and send the sound velocity information to shared memory for use by other programs like HYSWEEP®.

Version Number: 10.0.0.3

Device Name: Odin MVP Sound Velocity Driver

DEVICE SETUP

Generate Output Messages: Generates messages or data outside of the Raw file.

This driver sends the navigation data from shared memory in NMEA 0183 messages to the device.

DRIVER SETUP

FIGURE 1. MVP Driver Setup

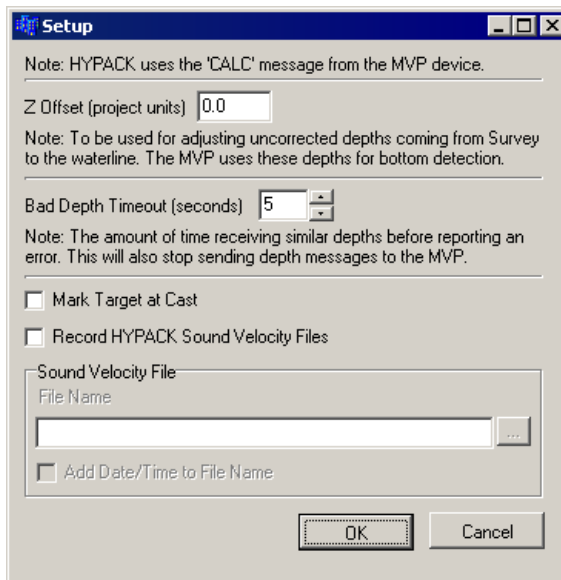

Z Offset: This is the distance from the waterline to the echosounder transducer. The MVP device applies this draft

correction value to the uncorrected depth data sent by the driver (See “Driver Output Strings”.) to determine the cable out for the MVP cast.

Bad Depth Time out: The amount of time receiving depths before reporting an error. At this time, the driver also stops sending depths.

Mark Target at Cast: Generates a target at each cast site. Select this option if you feel it is useful to know each cast location.

Record HYPACK® Sound Velocity Files: Creates VEL files on each update to the user-specified file name for use in post-processing.

NOTE: Though HYSWEEP® reads the profile data in real time, it only records the data in the data file header at the start of each line. Therefore, for the best accuracy in the final data, the profile data should be recorded to multiple VEL files, which should then all be loaded into the HYSWEEP® EDITOR during post-processing.

Sound Velocity File: Name the VEL file to be generated.

Add Date/Time to File Name: Select this option to record data to multiple VEL files by adding the date and time the readings were taken to the file name.

DEVICE OUTPUT STRINGS

CALC message

DRIVER OUTPUT STRINGS

Writes SV Profile information to Shared Memory. HYSWEEP® SURVEY reads and displays the values in Shared Memory in real time.

Optionally, it creates HYPACK® sound velocity files on each update.

DEVICE WINDOW:

FIGURE 2. Sample Device Window

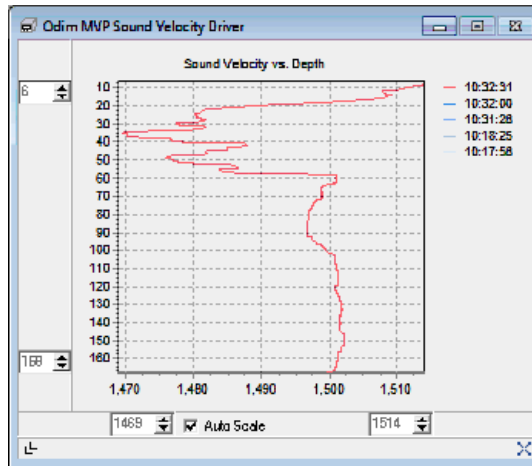

The graph will show the last five profiles, with the latest in red and the older ones in increasingly lighter shades of blue.

You can autoscale the graph window to the extents of the readings or manually setting the extents via the text boxes on the corners of the graph. If autoscaling is not being used, the button on the bottom right can be used to zoom to the extents of your data.

The button on the bottom left will hide or show the extents frames. You can set it to autoscale then hide the extents frames to get more graph space in the window.

SERIAL PORT:

Outputs GGA, VTG, DBT, ZDA strings to the device based on Shared Memory information.

KNOWN DEVICES SUPPORTED

Odin MVP Sound Velocity Profiler

SPECIAL NOTES

NMEA.DLL

Version Number: 13.0.8.6

Device Name: NMEA 0183

DEVICE SETUP

Depth: Logs soundings or magnetometer data from this device.

Heading: Logs heading data from this device.

SURVEY will use that as the primary orientation information; you should not click the GPS heading on, as your boat will switch between gyro and GPS orientation as each device updates.

NOTE: If you are using the Line Azimuth as Heading option in the Driver Setup, do not check this box.

Speed: Displays speed data from this device.

In this case, it tells SURVEY to use the speed information from the VTG message for the vessel speed. The GPS speed is much smoother and more accurate than the speed SURVEY will calculate.

Heave: Logs pitch and roll data from this device.

This option is for units that output both heading and pitch-roll data. *The device must output a PNTLR,ATT message.*

Use for matrix update: Color-codes a matrix based on the data received from this device.

Paper Annotation: Annotates each event on the sounder's paper roll. (See Driver Output.)

Applicable only to echosounders with annotation capability.

Record Raw Messages: Logs the data string to the raw file as it is originally received from the device.

Generate Output Messages: Generates messages or data outside of the Raw file.

Tip:

We suggest that you try the NMEAOutput driver.

Record device specific messages: Logs additional data related to the device to the Raw file. Each record will be identified by a driver-specific, 3-character tag.

DRIVER SETUP

FIGURE 1. Driver Setup

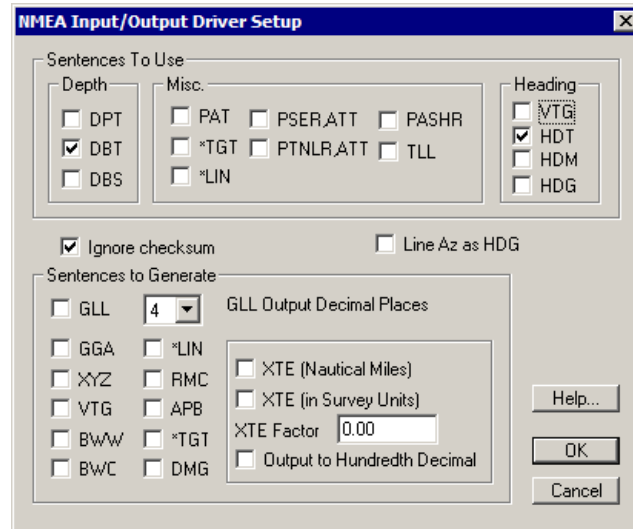

Sentences to Use: Select device input strings the driver will read for each type of data.

NOTE: HYPACK® tends to work more reliably if you choose no more than one sentence type/data type.

Ignore checksum: Some devices output NMEA strings that include a checksum digit to verify good data. Some devices did not follow industry standards when computing their checksum. The result would be no data and constant “Bad Checksum” messages in the I/O TEST and SURVEY programs. If this happens to you, return to the HYPACK® HARDWARE program and click on the Ignore Checksum box in the Driver Setup dialog.

Line AZ as HDG requires a planned line file. Uses the azimuth of the current survey line as the heading. *If you are using this option, clear the heading check box in the Device Setup.*

The **Sentences to Generate** option is only applicable if you have selected the ‘Generate Output Sentences’ option in the Device Setup dialog. Select the messages you want to export.

Tip: We suggest you use the NMEAOutput driver for this purpose.

TABLE 1. *Strings and Their Output Data*

Selected String	Output Data
GLL	Position Information (Lat/Long/Time only)
GGA	Position/Status Information
XYZ	Position and Depth Information
VTG	Velocity & Heading
BWW	Bearing–Weigh point-to-weigh point
BWC	Bearing and Distance
*LIN	DOS ver. HYPACK® Line File
RMC	Recommended Minimum specific GPS/transit data– Time, date, position, course and speed
APB	Autopilot sentence B (nautical miles)
*.TGT	HYPACK® Target Information (non-NMEA)
DMG	Distance Made Good
XTE (Nautical Miles)	Outputs Cross Track Error in Nautical Miles
XTE (Survey Units)	Outputs Cross Track Error in Survey Units
XTE Factor	Multiplies the Cross Track Error by a user-defined constant.
Output to Hundredth Decimal	Outputs Cross Track Error to 2 decimals. If this is not selected, the output will be to 1 decimal.

DEVICE OUTPUT STRINGS

Depends on the device. This driver reads any of the strings listed under ‘Sentences to Use’ in the Driver Setup.

DRIVER OUTPUT STRINGS

DEVICE WINDOW:

Writes original string.

Formats the parsed value to 2 dec. places and writes:

ValueName=Value.

SERIAL PORT:

Strings selected in 'Sentences to Generate' option of the driver setup.

SPECIAL NOTES

- You can use the NMEA.dll for multiple devices by installing the driver once for each device and assigning different ports.
- When outputting the XTE (Cross Track Error) to autopilots, you can elect to have the output in nautical miles or in survey units (meters/feet). Many autopilots were intended to receive XTE information in 0.1nm resolution. Sending it metric/foot information will cause it to over-steer.
- Beginning w/ the 2011 release, nmea.dll no longer supports position.

NOTE: Users w/ nmea.dll included in their configurations will have to update their setup configuration as *the new driver is not compatible with older configuration files.*

NMEAOUTPUT.DLL

Version Number: 16.1.1

Device Name: NMEA-Output

DEVICE SETUP

Generate Output Messages: Generates messages or data outside of the Raw file.

This driver generates and sends user-defined NMEA sentences out the serial port.

Paper Annotation: Annotates each event on the sounder's paper roll. (See Driver Output.)

DRIVER SETUP

FIGURE 1. Driver Setup

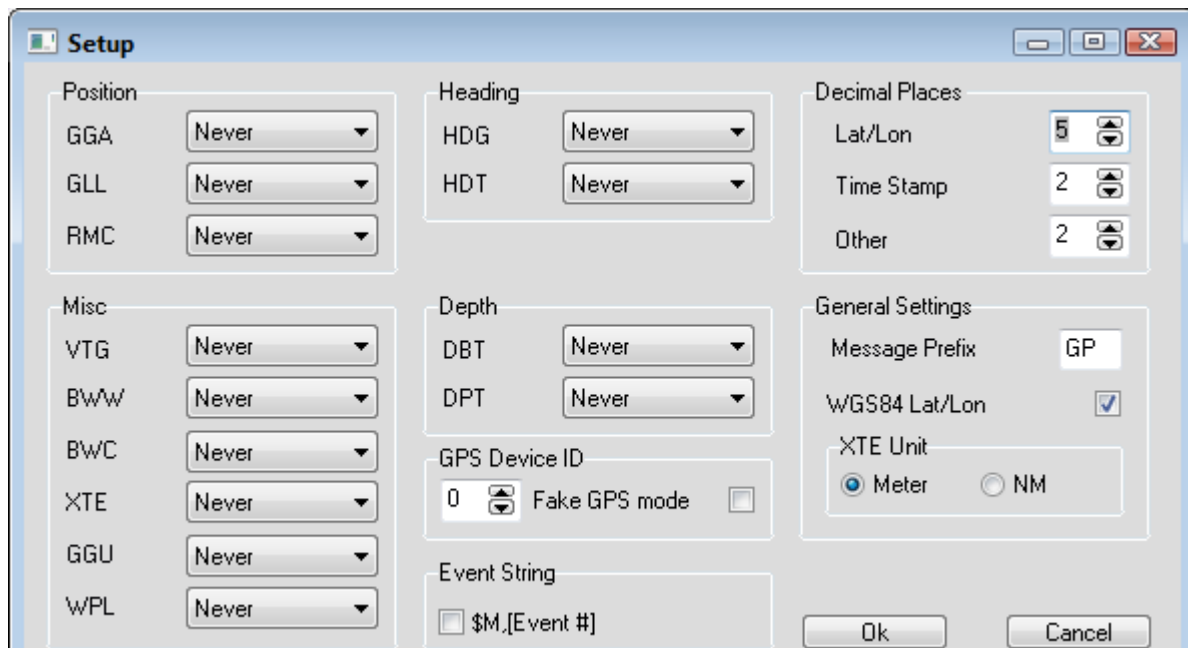

Select which NMEA sentences the driver should generate. They will be output at the Driver Update Rate. Sentence formats supported include the following:

Depth	DBT, DPT
Heading	HDG, HDT
Position	GGA, GLL, RMC
Miscellaneous	VTG, BWB, BWC, XTE, GGU, WPL

GPS Device ID: The device number of the GPS from which the driver should read data.

Fake GPS mode: The following GPS details are hard-coded in the GGA sentence:

- Mode = 2
- # Satellites = 7
- HDOP = 0
- Ellipsoid Height = 0

When unselected, these values are taken from a GPS driver.

Event String: For each event, the driver includes the \$M, EventNumber string in the output.

Decimal Places: Configure the number of places after the decimal for each value listed: Lat/Lon, Time Stamp, all Other numeric values.

Message Prefix: Tag that begins each output string from this driver.

WGS84 Lat/Lon: Check this option to output Lat/Lon in WGS84. Otherwise, it is output in local coordinates.

XTE Unit: If you are generating XTE strings, choose the distance units: Meters or Nautical Miles

DEVICE OUTPUT STRINGS

None.

DRIVER OUTPUT STRINGS

DEVICE WINDOW:

Designated output is shown in a scrolling display.

The output sentence choices can be changed in the Device Window in SURVEY.

SERIAL PORT:

NMEA strings based on the selections made in the [Driver Setup](#) and the information in Shared Memory.

SPECIAL NOTES

13.0.4.5: Output applies offsets to position messages without needing the genoffset.dll.

NOAACo-OPS.DLL

Version Number: 17.0.0

Device Name: NOAA MyPorts

Displays real-time information from the NOAA CO-OPS system.

DEVICE SETUP

Generate Output Messages: Generates messages or data outside of the Raw file.

This driver reads the station data from the NOAA web site and displays the user-defined product values in the device window.

DRIVER SETUP

FIGURE 1. Driver Setup

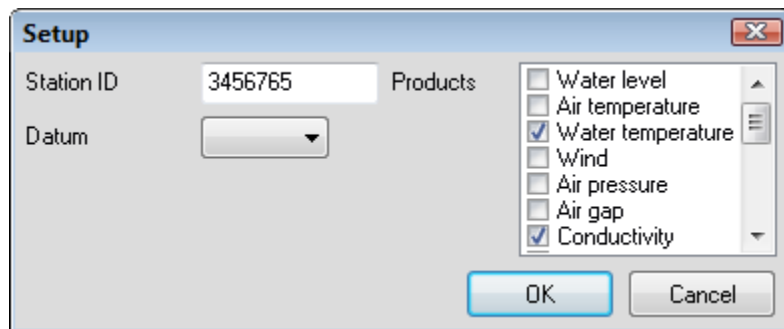

Station ID: A 7-digit number unique to the NOAA tide station.

Datum: Required for all water level Product selections. Use the same datum as specified in your project geodesy.

Products: Choose from these values to display in the device window:

TABLE 1. Product Display Options.

Product	Definition
Water Level	Preliminary or verified water levels, depending on availability.
Air Temperature	Air temperature as measured at the station.
Water Temperature	Water temperature as measured at the station.

Product	Definition
Wind	Wind speed, direction, and gusts as measured at the station.
Air Pressure	Barometric pressure as measured at the station.
Air Gap	Air Gap (distance between a bridge and the water's surface) at the station.
Conductivity	The water's conductivity as measured at the station.
Visibility	Visibility from the station's visibility sensor. A measure of atmospheric clarity.
Humidity	Relative humidity as measured at the station.
Salinity	Salinity and specific gravity data for the station.
Hourly Height	Verified hourly height water level data for the station.
High/Low	Verified high/low water level data for the station.
Daily Mean	Verified daily mean water level data for the station.
Monthly Mean	Verified monthly mean water level data for the station.
One Minute Water Level	One minute water level data for the station.
Predictions	6 minute predictions water level data for the station.
Datums	Datums data for the stations.
Currents	Currents data for currents stations.

NOTE: All stations do not provide all of these products.

DEVICE OUTPUT STRINGS

No device. This driver polls station for the selected data (products) in the Driver Setup.

DRIVER OUTPUT

DEVICE WINDOW

Displays the station name and a 2-column table with your selected data. The driver updates the display at 1-minute intervals, and shows the last update time in the status bar.

NOTE: Stations update only once every 6 minutes.

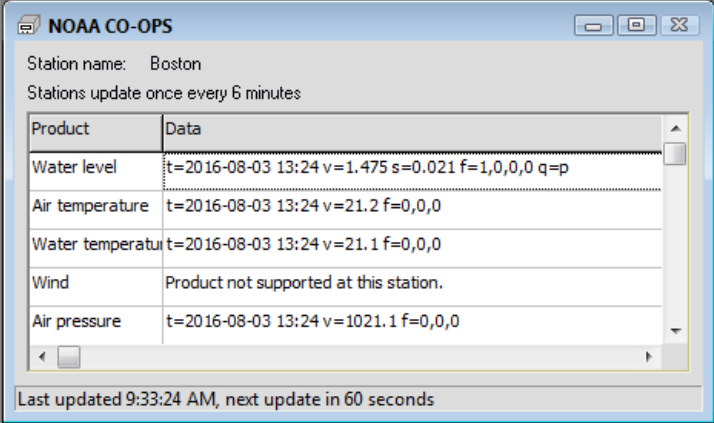
FIGURE 2. Sample Device Window

The screenshot shows a window titled "NOAA CO-OPS" with the following information:

- Station name: Boston
- Stations update once every 6 minutes

Product	Data
Water level	t=2016-08-03 13:24 v=1.475 s=0.021 f=1,0,0,0 q=p
Air temperature	t=2016-08-03 13:24 v=21.2 f=0,0,0
Water temperature	t=2016-08-03 13:24 v=21.1 f=0,0,0
Wind	Product not supported at this station.
Air pressure	t=2016-08-03 13:24 v=1021.1 f=0,0,0

At the bottom of the window, it states: "Last updated 9:33:24 AM, next update in 60 seconds"

SPECIAL NOTES

Information about data accessed by this driver: <http://co-ops.nos.noaa.gov/api/>

NOAAWEATHER.DLL

Version Number: 16.1.0

Device Name: NOAA Weather Display

DEVICE SETUP

Generate Output Messages: Generates messages or data outside of the Raw file.

DRIVER SETUP

None

DEVICE OUTPUT STRINGS

No device. Polls data from NOAA/NWS XML output at <http://forecast.weather.gov/MapClick.php?lat=41.5933&lon=-72.7241&unit=0&lg=english&FcstType=dwml>

DRIVER OUTPUT

DEVICE WINDOW

A three-tabbed display with current and forecast weather for the weather station nearest your current vessel position, as well as the Area Forecast Discussion, all from the National Weather Service website.

FIGURE 1. Sample Device Window Displays

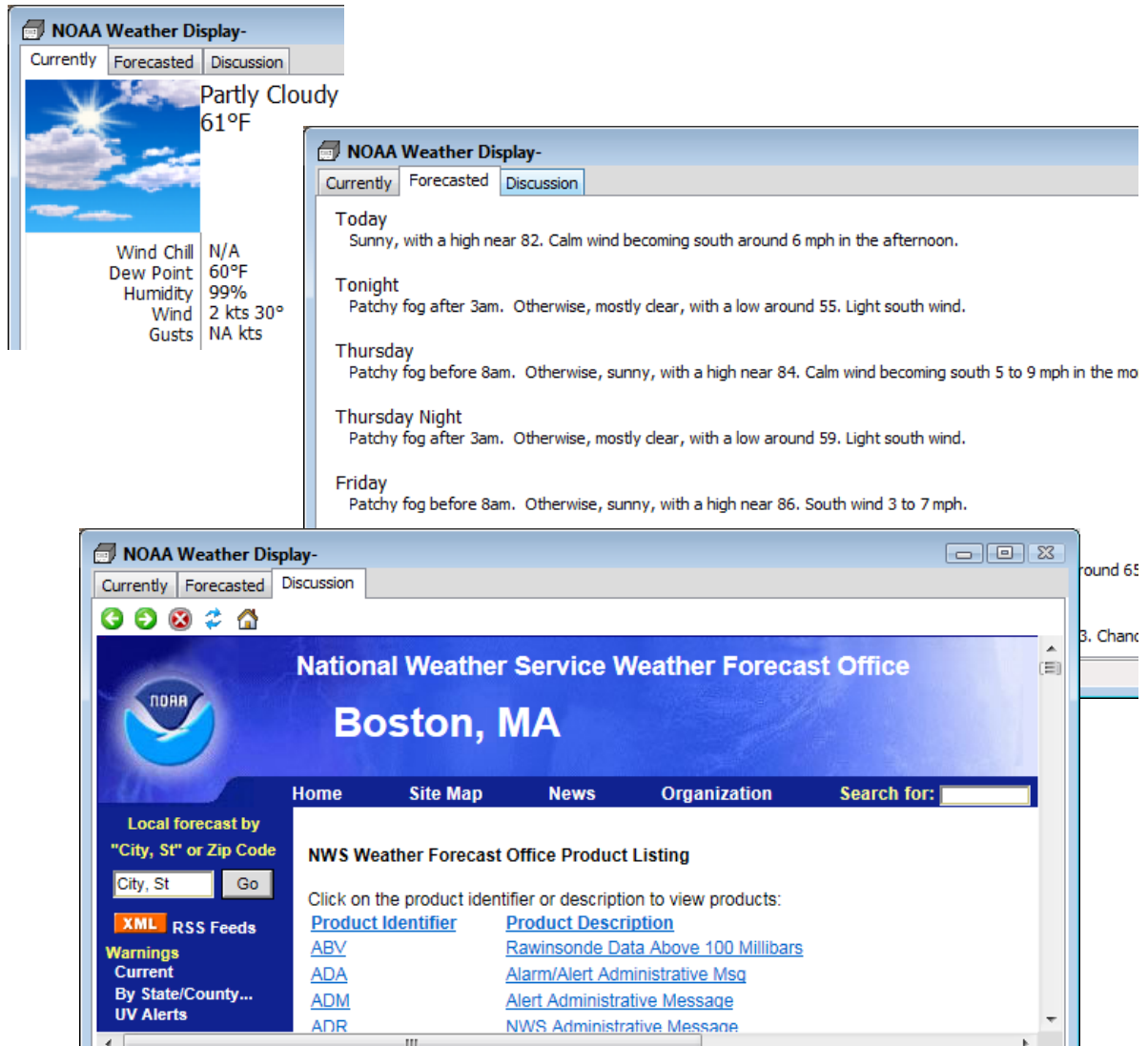

SPECIAL NOTES

Requires active positioning device to determine the nearest weather station.

This driver can only populate the display in HYPACK® SURVEY. The driver test display in HARDWARE provides no position.

PLAYBACK.DLL

Used to recreate a survey by replaying *.RAW data files in HYPACK® SURVEY. It can read individual files or catalog files.

Version Number: 15.0

Device Name: HYPACK® Playback Driver

DEVICE SETUP

Check data that the driver should attempt to read from the raw data file(s).

Position

Depth

Heading

Tide

Heave [for heave pitch and roll]

Draft

Use for matrix update: Color-codes a matrix based on the data received from this device.

NOTE: The Depth option must be selected to provide data for this option to update the matrix.

DRIVER SETUP

FIGURE 1. Driver Setup

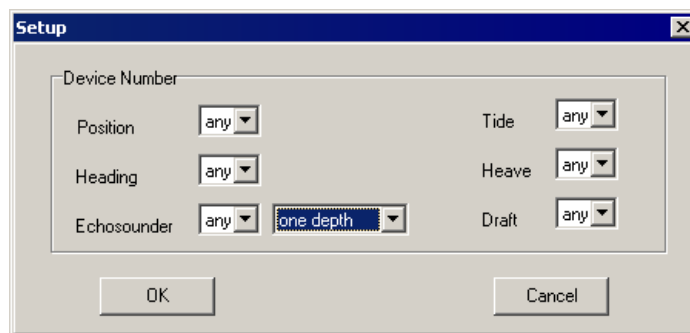

Select the device number for each string type selected in the device setup. This allows you to specify which data should be read from the RAW file selected in the Playback.dll Connection settings, even if there are multiple devices logging the same type of data.

DEVICE OUTPUT STRINGS

Data from raw file(s) indicated in the Connection setting.

DRIVER OUTPUT STRINGS

DEVICE WINDOW:

Playback controls:

FIGURE 2. Playback Device Window

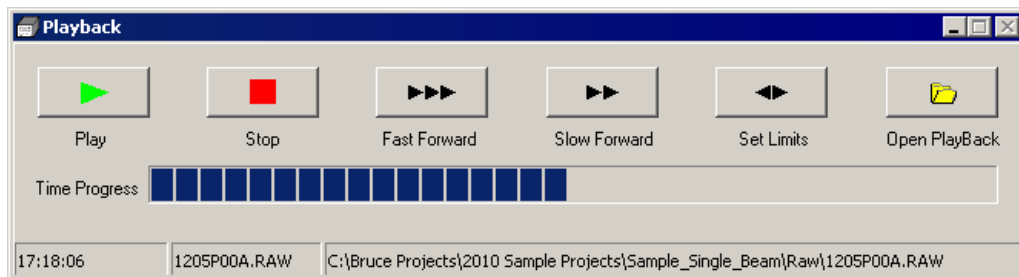

- **[Set Limits]:** Set a time range in the file from which the driver should read.
- **[Open Playback]:** Use this to select a raw file to replay.

SPECIAL NOTES

- Has its own dialog in SURVEY which allows you to select a different data file.
- In addition to the values types read, it displays time and date in the data display.

SEABEDID.DLL

Version Number: 13.0.1

Device Name: Seabed Identification Devices

DEVICE SETUP

Depth: Logs soundings or magnetometer data from this device.

Use for matrix update: Color-codes a matrix based on the data received from this device.

Record Raw Messages: Logs the data string to the raw file as it is originally received from the device.

Record device specific messages: Logs additional data related to the device to the Raw file. Each record will be identified by a driver-specific, 3-character tag.

The SeabedID.dll tags its message with ROX.

DRIVER SETUP

FIGURE 1. SeabedID Setup Dialog

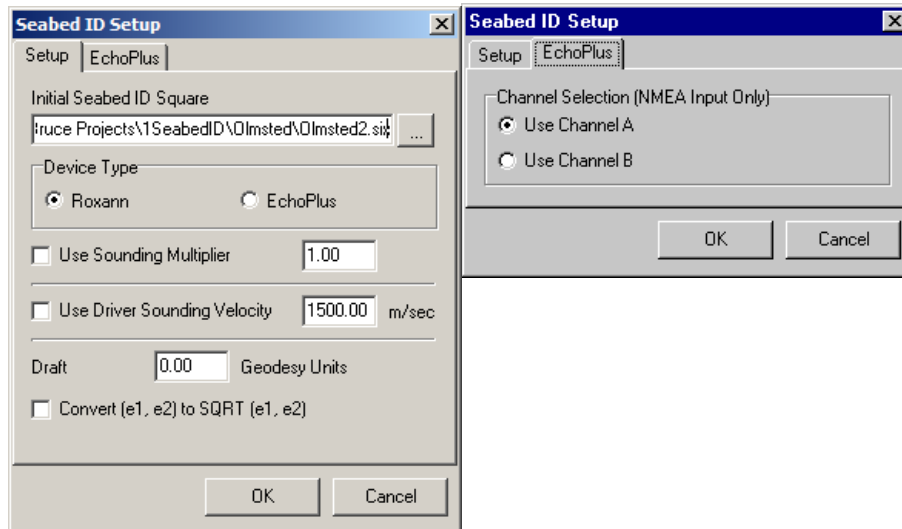

Setup Tab:

Initial Seabed ID Square sets the ID square first displayed in the device window. The Device Window includes a File Open icon from which you can select a different one.

Device Type indicate which seabed device you are using.

For Roxann devices only. These options are used to calculate depth:

- **Use Sounding Multiplier:** It multiplies the depth reading by this factor.
- **Use Driver Sounding Velocity:** Roxann stand-alone unit defaults to 1500 m/sec.. Your system uses another setting, check the box and enter your setting here. The sound velocity is also recorded to the Raw data files.

Draft:

Convert (e1, e2) to SQRT (e1, e2): Makes it easier to plot Seabed ID areas when e1 and e2 are less than 1. It also helpful where 3rd party systems require the square root value.

Echoplus Tab:

Channel Selection set which channel you want to read

DEVICE OUTPUT STRINGS

ECHOPLUS:

\$PSAP,?,xx,D,dddd.dd,M,R,r.rrr,H,h.hhh,C,csss<CR><LF>

\$PSAP	Tag
I	message type header
xx	00: Depth message 20: Lost signal message
D	Depth label
d	
M	Depth Units Depth is represented by a fixed length (seven characters, two decimal places) ASCII string including leading zeros and is measured in meters. Depth is measured from the transducer and not the sea surface. The valid range of depths is from 0.01m to 9999.99m
R	Roughness label
r	Roughness is represented by a fixed length (five characters, three decimal places) ASCII string measured on a scale such that a sandy seabed has a nominal roughness of 1. The valid range of hardness is from 0.000 to 9.999.
H	Hardness label

h	Hardness is represented by a fixed length (five characters, three decimal places) ASCII string measured on the scale such that a sandy seabed has a nominal hardness of 1. The valid range of hardness is from 0.000 to 9.999.
C	Channel Code label
c	The frequency channel code is used to indicate the source of the data. Channel A or Channel B.
ss	Checksum delimiter () and checksum.
Sample String:	
\$PSAP,I,00,D,0069.91,M,R,0.979,H,1.627,C,A*4A<CR><LF>	

ROXANN:

D0075F0107S0036

DRIVER OUTPUT STRINGS

Saves a ROX string as follows:

ROX 0 39282.252 2 0.070 0.072

ROX *DevNo TimeTag NumValsFollowing E1 E2*

For each incident of this device, there are 2 graphical displays.

Seabed ID Square Display:

The Seabed ID Square display plots each E1/E2 pair against your SeabedID Square. This window includes a control panel to customize the display setting.

FIGURE 2. *Seabed ID Square Display*

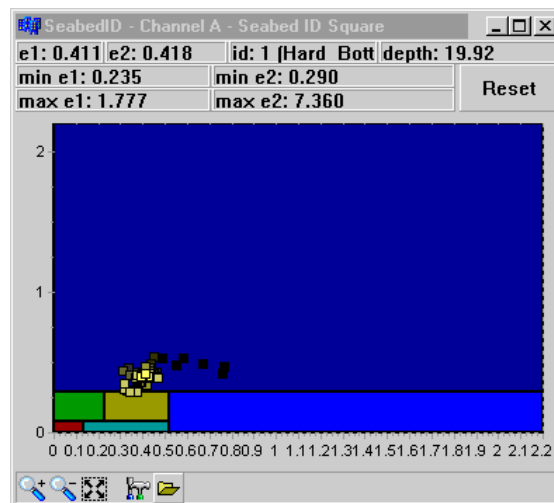

The range of the display matches the range of the Seabed ID Square, but you can specify a range by checking the "**Override SIX Min/Max**" box and setting the E1 and E2 ranges.

FIGURE 3. Setup Dialog for the SeabedID Square Window

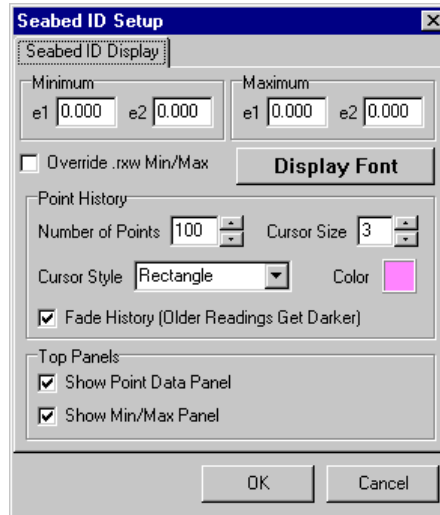

[Display Font] affects the text in the top panel.

Point History:

- **Number of Points:** The number of points that can be plotted.
- **Cursor Size, Style and Color** determines the appearance of each reading.
- **Fade History** darkens the earlier points in the display to help distinguish the newer data from the older which can be particularly helpful if a lot of the data overlays.

Top Panel settings toggle the text displays at the top of the dialog on/off.

Echosounder Display:

The Echosounder Display plots the depths over time.

FIGURE 4. SeabedID Echosounder Display

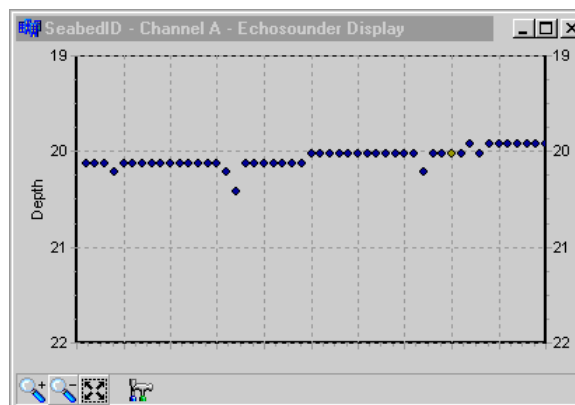

To access the view options for the Echosounder Display, click the Control Panel icon.



FIGURE 5. Setup for the SeabedID Echosounder Display

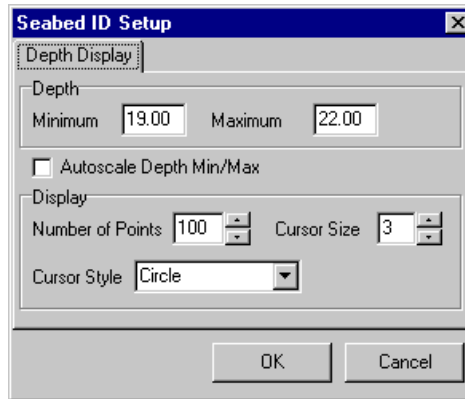

Depths:

- **Minimum and Maximum** fixes the graph range.
- **Auto-scale Depth Min./Max.** sets the graph range according to the range of the depths in the display.

Display:

- **Number of Points** is the maximum number of points that will appear in the graph at any one time.
- **Cursor Size and Style** determines the appearance of each reading. These are always black.

SPECIAL NOTES

KNOWN SUPPORTED DEVICES

- Roxann
- Echoplus

ROXANN CALCULATION

The Depth data in the ROXANN string is the two-way travel time (in milliseconds) of the echosounder pulse, so the Depth must be calculated by the driver.

Depth = (D-value * SV)/(2 * 76800) for Depths less than 100 m.

From the string "D0075F0107S0036" :

$(75 \text{ cycles} * 1500) / (2 * 76800 \text{ Hz}) = 0.732 \text{ m. in Depth}$

DRIVER CALCULATIONS

4/25/13 (ver 13.0) No longer gets geodesy from geo32.dll.

For informational purposes, here is the path that a depth reading travels in the SeabedID driver:

1. Reads the raw number.
2. If Roxann then it multiplies that number by 0.098. If Echoplus, then it multiplies that number by 0.100. (This step is skipped with the "new," NMEA-like Echoplus string.)
3. Then multiplies the new number by either the sound velocity specified in the driver divided by 153600, or the sound velocity specified in Survey (Setup Option) divided by 153600.
4. Then it optionally multiplies the new number by a multiplier specified in the device setup.
5. Then, assuming the number it has is in meters, adjusts the reading for geodesy.

SEABED IDENTIFICATION SURVEYS IN HYPACK®

Seabed Identification (Seabed ID) surveys have long been supported in the standard HYPACK® package. They require a specialized echosounder to record the data required to determine the bottom types and, although most routines used to process the data are centered in the SEABED STATISTICS program, some are less obvious.

The SeabedID device driver refers to a user-defined table of E1-E2 ranges and bottom classifications—the Seabed ID Square—to assign a Seabed ID number for each sounding record during SURVEY. The E1 and E2 values are time tagged saved with the Seabed ID number to an ROX record in the raw data file. If this driver is used to paint the matrix, SURVEY will fill the matrix using Seabed ID colors based on the Seabed Square created in SEABED STATISTICS for your survey area and designated in the driver setup. (You can also create a seabed matrix in post-processing using the SEABED MAPPER program.)

You may use Seabed ID colors to display your seabed matrix, soundings and track lines in HYPLOT. A TIN Model drawn with an XYZid file will draw to the screen using Seabed ID colors. You may also export your soundings in limited formats.

SEABED ID SYSTEMS

Certain echosounders record two echo return values (E1 and E2) in addition to the depth. These values vary according to the roughness and hardness of the bottom composition. This enables you to define various bottom types by a specific range of E1 and E2 values from the echosounder.

To do all of this requires a little preparation:

1. **Do your bottom truthing** in your survey area to determine the echo return values that correspond with each bottom type in your area.
2. **Use SEABED STATISTICS to create a Seabed ID Square.** This (*.SIX) file contains the classifications for your project area and their corresponding E1 and E2 ranges.
3. **Use the SeabedID device driver (SeabedID.dll) in your Hardware Setup**, specifying your Seabed ID Square (*.SIX) in the Driver Setup dialog.

NOTE: NOTE You can log data with no SIX file specified in the driver setup, but no Seabed IDs will be logged in the RAW data. (Obviously, you can not display them in

SURVEY either.) In this case, when you *do* have a SIX file, you can assign the Seabed IDs in either the RAW or edited ALL format files using the SEABED STATISTICS program.

SEABED STATISTICS

SEABED STATISTICS includes most routines used in Seabed ID surveys:

- **Generate the Seabed ID Square:** You can define a set of classifications for your project area in a Seabed ID Square and generate statistical data from the logged data. The Seabed ID Square includes:
 - A list of bottom types
 - Their corresponding E1 and E2 ranges from the echosounder data. (You have to have a Seabed ID system.)
 - A Seabed Identification color and number for each bottom type.

All of the data is saved to your project in an *.SIX file. The Seabed ID device driver uses the Seabed ID Square during SURVEY to apply classification numbers for each sounding record according to the E1-E2 range in which it falls. You can use these Seabed ID numbers to color your matrix in SURVEY or HYPACK®, or plot your soundings and track lines in HYPLOT. A TIN Model drawn with an XYZid file will draw to the screen using Seabed ID colors. You may also export your soundings in limited formats.

- **Reassigning Seabed IDs:** SEABED STATISTICS can read your logged data and assign new Seabed ID numbers according to a SIX file other than the one named in the SeabedID driver setup during logging. Use this routine if you logged without a SIX file named in the driver or if you need to correct the data logged with an incorrect SIX file.
- **Statistical Reporting:** SEABED STATISTICS reads All format data containing Seabed ID information (the E1 and E2 data), and graph the distribution of each set of data. The graph also indicates the return ranges within which 68% and 95% of the returns fall.
- **Export related files** for use outside of SEABED STATISTICS.
 - **A HYPACK® Colors file** (*.HCF) with your Seabed ID colors. You will need such a file to properly display your data using Seabed ID colors.
 - **A Color Bar graphic** with your Seabed IDs and colors for use in HYPLOT.

- **Text files** containing a selection of user-defined position coordinates and E1/E2 values.

CREATING A SEABED SQUARE IN SEABED STATISTICS

Before you can define the square, you must collect some sample data in various parts of your survey area where the bottom compositions differ to determine what bottom types exist and what their corresponding E1 and E2 ranges are. The number of readings necessary will vary depending on how much your survey area varies.

If you are working in the same general area of the world where the geological conditions are similar, it may be possible to use the same square for several projects. However, if the bottom types are significantly different, you will have to create a seabed ID square appropriate to each project area. (You wouldn't use the same square file in the Mississippi delta as you would on the rocky coast of Maine.)

Once you have gathered this information, you are ready to build your Seabed ID Square.

1. **Launch the SEABED STATISTICS** by selecting UTILITIES-SEABED -SEABED ID.
The Seabed ID window displays five resizable windows that can be toggled on and off through the View menu.
2. **Select FILE-NEW SEABED ID SQUARE.** The screen will clear, ready for the new information.
3. **Load calibration data (optional).** You can load your data files or just representative "calibration points" from each bottom type area to guide you.
4. **Define your bottom types with their corresponding E1 and E2 ranges.** You can load your data files or just a representative "calibration point" from each bottom type area to guide you.

FIGURE 1. *Seabed ID Square in Seabed Statistics*

5. **Modify the seabed identification colors (optional).** SEABED STATISTICS automatically assigns colors to each color range, but you can change them by double-clicking on the sample color to the left of each range

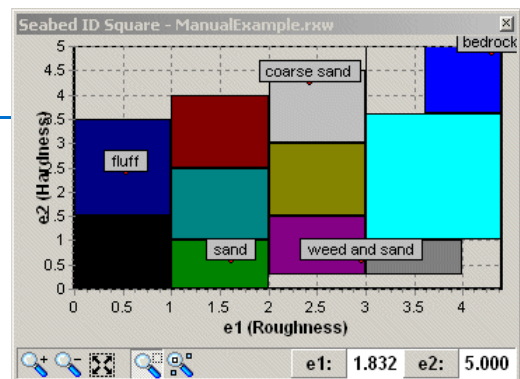

description. A color dialog will appear for you to select your desired color.

6. **Save the square** by selecting FILE-SAVE SEABED ID SQUARE and naming the file. The file will be saved with a SIX extension in the project directory.

NOTE: You can also save the same colors and ranges to the project's HYPACK® Color File (*.HCF) which will allow you to display your data using your seabed identification colors.

**LOADING
CALIBRATION
DATA TO SEABED
STATISTICS**

You can enter your sample data files, or manually enter information derived from them, to be displayed in the Seabed ID Square window. This data is useful to guide you while you define your E1 and E2 ranges for each bottom type.

LOADING DATA FILES TO SEABED STATISTICS

Select FILE-ADD MATERIAL then the Raw or All format files from the file selection dialog. When you do this the files are listed on the tree view file list at the left of the main window and displayed in the Seabed ID Square window.

Ideally, there would be one file for each bottom type. Whether you load them individually or using a LOG file, each file will display in a different color (up to 15) in the Seabed ID Square window.

To assign colors manually to each file or to all of the files in the catalog:

1. **Right-click on the file or catalog** in the tree view.
2. **Select 'Choose Color' and select your color** from the color dialog.

If you have right-click on a catalog, all files contained in the catalog will all be assigned the same color.

FIGURE 2. *Tree View File List*

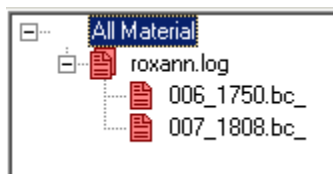
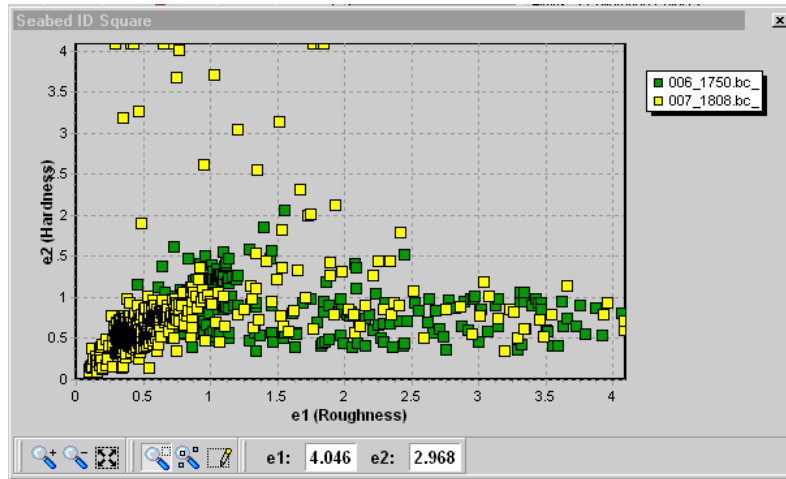

FIGURE 3. Viewing Sample Data



If some of your data files overlap, you can bring one set forward in the display by right clicking on the name in the tree view and selecting the "Highlight" option.

To unload data files from SEABED STATISTICS, right click on the name in the tree view and select the "Remove" option.

ENTERING FIELD SAMPLES TO SEABED STATISTICS

To enter a list of field samples, open the Calibration Points tab of Spreadsheet window and enter your bottom types with approximate E1 and E2 values. In this spreadsheet, the Notes field names the sample; it is not the seabed identification.

FIGURE 4. Entering Calibration Points

Spread Sheet				
Limits		Calibration Points		
Num	ID	e1	e2	Notes
1	1	.5	2	fluff
2	2	1.5	.5	sand
3	3	2.25	3.5	coarse sand
4	4	4.00	4.00	bedrock
5	5	2.75	.5	weed and sand
*				

Add Insert Delete

FIGURE 5. A blank Seabed ID Square with Calibration Points displayed

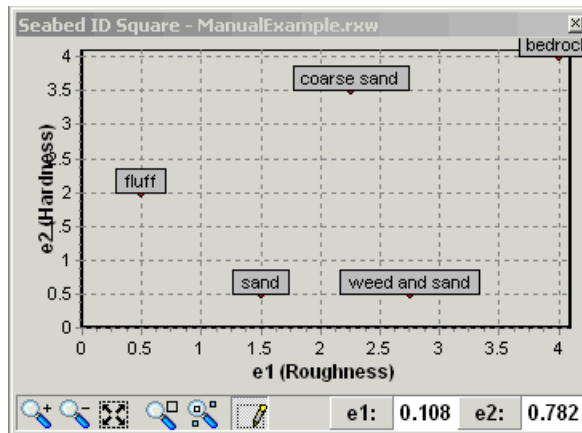

**ENTERING
SEABED
CLASSIFICATION
RANGES IN
SEABED
STATISTICS**

In the previous versions of Seabed Statistics, the defined ranges for the roughness (e1) and hardness (e2) identification were rectangular.

FIGURE 6. Seabed ID Square in Seabed Statistics

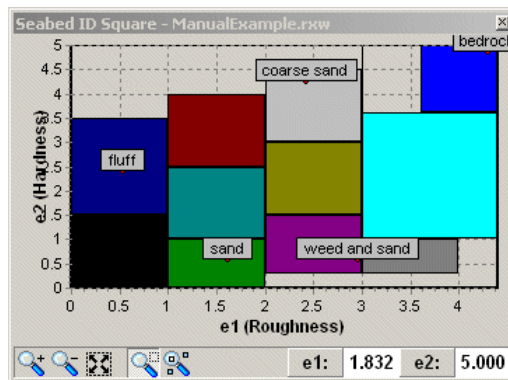

Because the scatter from the roughness and hardness readings on a particular surface are not square, we now support “polygon” ranges to better “fit” the scatter areas.

You can define the ranges using one or both of the following methods.

- **Manually type the information to the Limits tab of the Spreadsheet window.**
 - a. **Create a new range name** by pressing the “Add” button on the *left* side of the Spreadsheet window and typing the name into the space created in the spreadsheet.
 - b. **Define your range** by pressing the “Add” button on the *right* side of the window, once for each point needed to define your range, then manually entering the hardness/roughness (e1/e2) levels that define the range.

As each classification is defined, the corresponding area will be drawn in the Seabed ID Square window.

FIGURE 7. The Edit Ranges Spreadsheet



ID	Name	e1 (Roughness)	e2 (Hardness)
0	Rock	2.545	0.251
1	Sand	2.521	0.730
2	Mud	2.036	0.866
3	Coral	1.243	0.741
4	Shell	1.195	0.285
5	Seaweed	*	*
6	Eel Grass		
7	Unidentified 1		
8	Unidentified 2		

Seabed ID Square

Minimum e1	0.000	Minimum e2	0.000
Maximum e1	4.095	Maximum e2	5.000

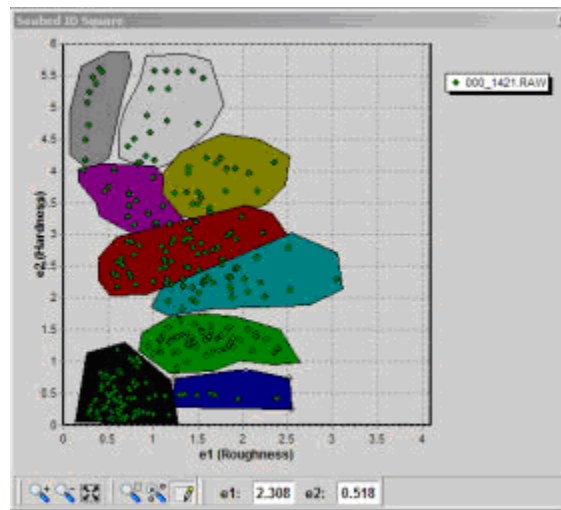
FIGURE 8. The resulting Seabed ID Square



- Use the cursor to draw the ranges in the Seabed ID Square window.
 - a. Click the Range Edit Icon on the bottom of the Seabed ID Square window. This will change the cursor to the Range Edit cursor.  
 - b. Define the polygon.
 - i. Press the “Shift” button. When you press the Shift button the cursor changes to let you know you are adding points. *Keep it pressed as you click all the points in the range perimeter.* 
 - ii. Click the points around the perimeter of your polygon. As you click on the screen the polygon will be built.
 - iii. Close the polygon by releasing the Shift key.

EDITING SEABED SQUARES

To create another new range, press the Shift button again and click the points for the new range.

As you are developing the Seabed Square for your project area, you may need to modify your settings or add new ranges.

1. **Load the seabed square into SEABED STATISTICS** by selecting FILE-OPEN and choosing the SIX file you wish to edit.
2. **Modify your square.**
 - Define additional ranges.
 - Change your current range settings. You can enter new values in the spreadsheet or use the cursor in the Seabed ID Square window.

To change existing range settings:

1. Select the range.
2. When a range is selected, you can add nodes to the border or move the existing nodes.

SELECTING A SEABED RANGE



1. **Enter Range Edit Mode.** (Press the Range Edit Icon.)
As you move over an unselected range with the mouse you will see a Range Select cursor. 
2. **Click on any range in the Seabed ID Square window.**
The cursor will change to the Node Edit Cursor while it is within the selected range and the nodes defining the selected range will be displayed (shown below). 

FIGURE 9. The range on the right is selected (active/current range).



A range can also be selected by clicking on it in the Spreadsheet window.

ADDING A NODE TO THE SELECTED RANGE

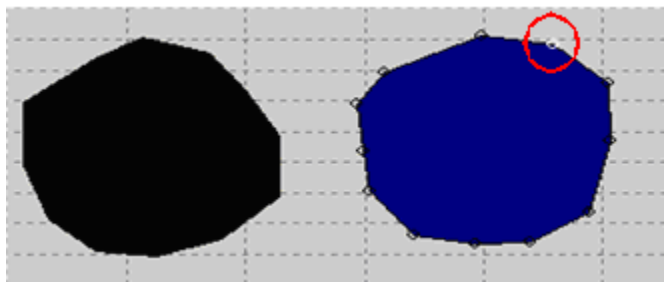
A new node must be added on an existing edge.

1. **Press the Shift key.** (Remember, new points can only be added with the Shift button pressed.)

2. **Move the cursor** (with the Shift key pressed) over an edge of the selected range. You will notice the Node Addition cursor. 
3. **Click on the point where you want to add a node on that edge.**

Nodes can also be added by using the Spreadsheet window.

MOVING A NODE ON THE SELECTED RANGE

To move a node:

- **In the Seabed Square**, move the cursor over a node point on the selected range. When the cursor changes to the Node cursor, click and drag the node to the new position. 
- **In the Spreadsheet** by changing the roughness/hardness (e1/e2) values for that node in the Spreadsheet window. When you select a node either by the Node tool or the spreadsheet window, that node is drawn in white (circled in the previous image) on the Seabed ID Square window.

CREATING SEABED STATISTICS

The second function of SEABED STATISTICS is to read and analyze the E1 and E2 values in the survey data you have loaded to the program, then present statistical information about it. **Four windows display the data statistics.**

When you load survey data to SEABED STATISTICS:

- **The file names are listed in the tree view on the left.**
- **The statistics are automatically calculated and displayed.**

BEWARE!

If you have loaded data files that should not be included in the statistical analysis, you must omit them from your display and statistical calculations by right clicking on the name in the tree view and clearing the "Enable" option.

- **E1 Distribution and E2 Distribution windows:** The distribution of the E1 and E2 values are graphed in the two distribution windows.

FIGURE 10. E1 Distribution Graph

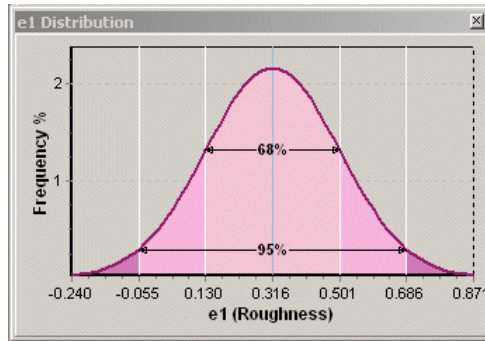
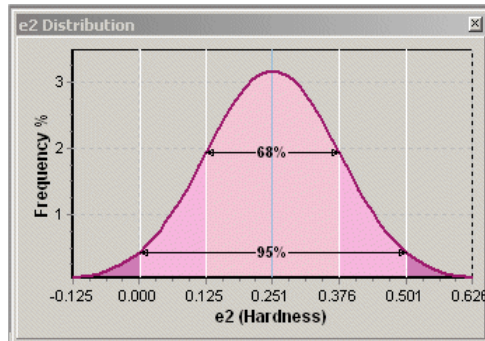

FIGURE 11. E2 Distribution Graph



- The **Material Statistics** display presents the same data in numeric form.

FIGURE 12. Material Statistics

	Points	Min	Max	Sigma	-2	-1	Mean	+1	+2
					Sigma	Sigma		Sigma	Sigma
e1	1395	0.100	4.090	0.734	-0.741	-0.007	0.727	1.461	2.195
e2	1395	0.090	4.090	0.418	-0.145	0.273	0.691	1.109	1.528

- The **Seabed ID Square** overlays the E1 and E2 data on the classification squares.

FIGURE 13. E1 and E2 overlays the Seabed ID Square

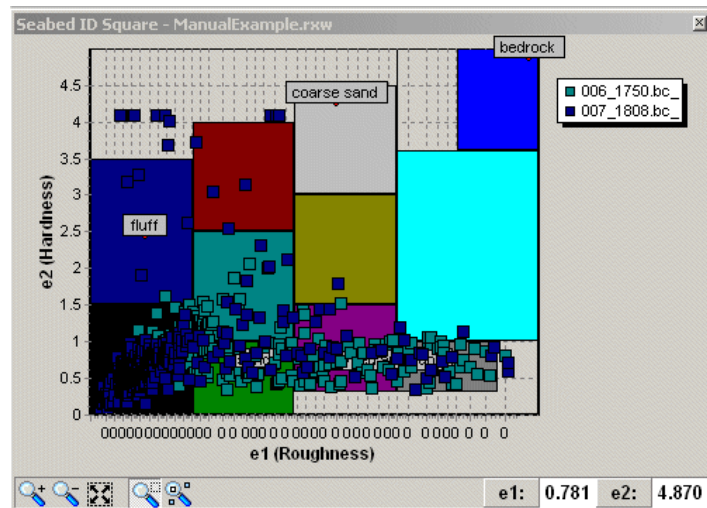

The tools in the Seabed ID Square window enable you to remove any data from the statistical analysis. You can omit selected data points or entire files from your display and statistical calculations.

To omit select data points:

1. **Click on the Material Selection Icon** (right-most on the toolbar).
2. **Drag an area around the data** you want to remove with your cursor. The selected points will turn white. If you are not satisfied with the selection, you can:
 - **Make a new selection** by dragging a new area.
 - **Deselect the data** by selecting EDIT-CLEAR SELECTION.
3. **Select EDIT-DELETE SELECTED MATERIALS** or hit the Delete key. The Material Statistics and the E1 and E2 Distribution displays will all update accordingly.

To omit entire data files:

Right-click on the name in the tree view and clear the "Enable" option.

NOTE: This does *not* delete the data from the data files.

REASSIGNING SEABED IDENTIFICATION VALUES

The Seabed Square is used by the SeabedID.dll to assign Seabed Identification values to each sounding record. In SEABED STATISTICS, you can reassign these values based on a different Seabed Square. When you do this, SEABED STATISTICS creates a new set of data files with the modified identification numbers.

1. **Open the new Seabed Square** by selecting FILE-OPEN SEABED ID SQUARE.
2. **Load your sounding files** by selecting FILE-ADD MATERIAL then the Raw or All format files from the file selection dialog.
3. **Select FILE-REMAP MATERIAL**. A dialog will appear with a number of options for naming the remapped files.

FIGURE 14. Seabed Statistics Remap Dialog

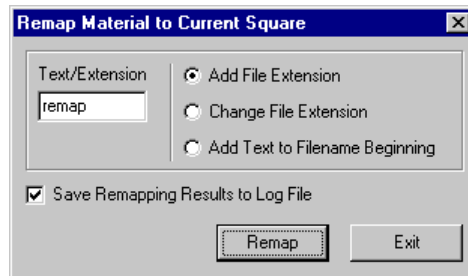

- **Text Extension** sets the extension to be used in naming the files. There are three ways this text can be used. The following table describes each option. The sample names result from using "new" as the text to reassign 041_322.edt which is listed in the FirstOne.log.
 - **Add File Extension** adds a "." followed by your text to the end of your text name. Ex. 041_1322.edt.new, FirstOne.log.new.log
 - **Change File Extension** replaces the original extension with the text. Ex. 041_1322.new, FirstOne.new.log
 - **Add Text to Filename Beginning** begins each file name with your text. Ex. new041_1322.edt, newFirstOne.log
 - **Save Remapping Results to Log File** creates a catalog file listing all remapped files.
4. **Enter your settings and click [Remap]**. A window will appear with a line-by-line accounting of the conversion and the converted files will be saved to the same folder as the original data files.

EXPORTING FROM SEABED STATISTICS

Once you have configured your seabed square and loaded your survey data to the SEABED STATISTICS program, you can export the information to formats that may be useful in other modules or outside of HYPACK®.

TABLE 1. SEABED STATISTICS Export Formats

Seabed Data	Output
Selected Sounding and ID data	Text
Seabed ID Colors	HYPACK® Colors File (*.HCF)
Legend	Graphic (*.BMP)

EXPORTING SEABED DATA TO A TEXT FILE

SEABED STATISTICS can reassign the seabed identification values in your survey data and export selected data to a text file. This does *not* affect the input data files.

For each record, it reads the E1 and E2 values, refers to the currently loaded Seabed Square to determine the ID number and writes the requested information to the exported XYZ file.

Values available for output include the following data:

TABLE 2. Output Options from SEABED STATISTICS

• ID	• Z1	• E1
• X	• Z2	• E2
• Y		

To export your seabed data to text:

1. **Load your seabed square.** The identification numbers exported will be based on this square.
2. **Load your edited data files.** The depths, E1 and E2 data will come from these files.
3. **Select FILE-EXPORT MATERIAL** and the XYZ/ID Export dialog will appear for you to choose your export options.

FIGURE 15. XYZ ID Export Dialog

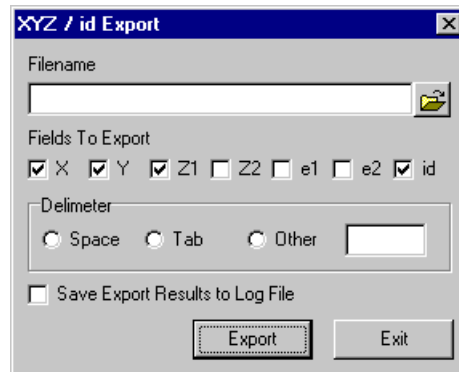

- **Filename:** Click the File Open icon and define the path and name for the exported file.

CONVERTING SEABED IDENTIFICATION COLORS TO PROJECT COLORS

- **Fields to Export** provides a series of check boxes, one for each type of data that may be included in the resulting text file. Check those that you wish to export along with the **Delimiter** that will separate each value.
4. **Click [Export]** and the text file will be created according to your choices.

You can export your Seabed Identification colors from SEABED STATISTICS to your project colors. By doing this:

- SURVEY can color-code the matrix using Seabed ID colors.
- HYPACK® can display a seabed matrix using seabed colors.

To export your colors:

- **When you save your SIX file**, SEABED STATISTICS asks you if you would like to save the color codes to an HCF file (HYPACK® Color File) and transfer the seabed color coding to the project color settings. The new HCF file will be named *SixFileName_six.HCF*.
- **Select FILE-EXPORT ID SQUARE TO HYPACK® COLOR FILE** and naming the file.

In either case, the new HCF file will be saved to the project directory. When you exit SEABED STATISTICS, it will be implemented in the HYPACK® display.

In order to avoid confusion, a brief explanation about how this works with seabed identification data is in order.

Each cell in a matrix file actually has space in the matrix code for two depths. (This is what allows us to show the survey depth, dredge depth or the difference between the two values in dredge projects.) When you are collecting seabed identification data, the SeabedID device driver stores the seabed identification number in the first memory space, and the depth in the second.

The HCF file normally specifies the color that goes with each depth range. When SEABED STATISTICS exports the seabed colors to the HCF, it saves a range for each seabed identification number (plus and minus 0.5) with its corresponding color. Since the seabed identification numbers are stored in the first "depth" memory, SURVEY reads it as a depth and colors the matrix accordingly.

To display a seabed matrix using Seabed ID colors in HYPACK®:

1. **Load your seabed colors HCF file to your project.**
2. **Right-click on the Matrix folder in the Project Files list and select 'Seabed ID'.**

GENERATING A SEABED LEGEND IN BMP FORMAT

The colors and bottom types defined in a seabed square may be exported to a labeled BMP file. This graphic may then be imported to HYPLOT for use as a legend in the smooth sheet plot.

Once you have loaded the seabed square to SEABED STATISTICS, select FILE-EXPORT ID SQUARE TO IMAGE (Ctrl+I) and name your output file in the dialog that appears. The file will be saved, by default, to the project directory.



SEABED ID IN MAPPER

If you have an echosounder that provides seabed identification data, you can create a Seabed Identification Square in SEABED STATISTICS then use SEABED MAPPER to:

- **Map your seabed identification (seabed ID) colors into a matrix** for display in MAPPER.
- **Export an X, Y, Z, ID file.**

The interface is much the same as MAPPER, but includes the enhancements necessary for the seabed identification features.

1. **Create a Seabed Identification Square** in the SEABED STATISTICS program.
2. **Launch SEABED MAPPER** by selecting UTILITIES-SEABED-SEABED MAPPER.
3. **Load the Seabed Identification Square** by selecting FILE-OPEN SEABED ID SQUARE.
4. **Open your Matrix file and, if it is a filled matrix, the data that should be included.** Set:
 - Load Soundings from Matrix = No
 - Add Soundings to Matrix = Yes and click [Update with Catalog File] to select your files that include the seabed identification information.
5. **If you have opened an empty matrix, load your soundings** by selecting FILE-LOAD SOUNDINGS and choosing your files that include the seabed identification information.
6. **Set your file options.** SEABED MAPPER includes an additional "Use Seabed ID" option. This tells the program to fill the matrix with seabed ID colors based on the seabed ID

information in each record and your seabed ID square, rather than with depth data.

FIGURE 16. SEABED MAPPER File Options

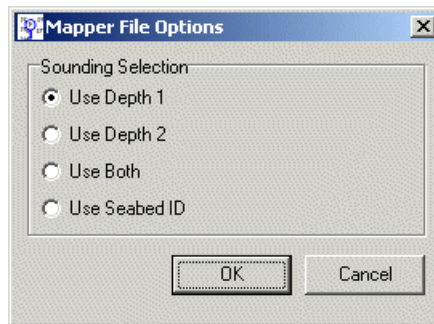

7. **Set your data selection options.**

FIGURE 17. Data Selection Options

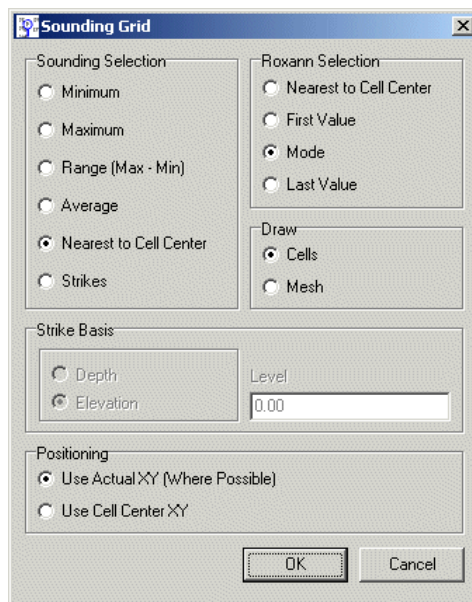

- **Nearest to Cell Center**
 - **First Value** in the file positioned in each matrix cell.
 - **Last Value** in the file positioned in each matrix cell.
 - **Mode** colors the cell according to the Seabed ID that occurs most often within the cell.
8. **Save your results.** SEABED MAPPER can store data in two formats:
- **Matrix files filled with seabed identification colors.** (Select FILE-SAVE SOUNDINGS-SAVE MTX FORMAT and name your file.)
A Seabed ID matrix can be displayed in the HYPACK® window by:

- i. Enabling them in the project files list.
- i. Setting HYPACK® to display seabed identification colors.
- ii. Loading the correct seabed identification square in the Soundings Tab of the HYPACK® Control Panel.
- **X, Y, Z, ID files: (Select FILE-SAVE SOUNDINGS-SAVE XYZID FORMAT and name your file.)**

Both of these file types can be used as the input file in TIN MODEL to model the seabed types in the terrain. and export matrix files and DXF files color-coded with seabed ID colors. TIN MODEL uses the seabed ID to color the model.

MODELING SEABED IDENTIFICATION VALUES

If you build a TIN model using an X, Y, Z, ID file or a seabed matrix, TIN MODEL will draw the model using seabed identification values..

To display your data using seabed identification colors:

1. **In SEABED STATISTICS, SEABED MAPPER, or GEOCODER™, export your data to XYZId format.** (SEABED MAPPER also exports a Seabed Matrix, color-coded using the seabed ID numbers.)

NOTE: The SeabedID numbers generated by GEOCODER™ range from 0-19 where 0 is the most coarse classification and 19 is clay. They are *not the same* as the classification numbers assigned in SEABED STATISTICS and SEABED MAPPER.

2. **Create a HYPACK® Colors file (*.HCF) to represent your Seabed ID colors.**

Tip:

In SEABED STATISTICS, you can export the seabed ID colors defined there to a HYPACK® color file. Use the COLOR EDITOR to create a color file to represent the 20 identification numbers generated by GEOCODER™.

3. **In HYPACK®, load the Seabed HCF file as your project color file.**
4. **In HYPACK®, set the matrix to display either Survey Depths or Seabed ID.** Either will work.
5. **In TIN MODEL, TIN your seabed ID values by using your XYZId (or Seabed Matrix file) as the input file.**

Since you have loaded your seabed colors as your project colors, your color TIN models should draw in seabed colors. Likewise, if

you export your TIN data and display it in the HYPACK® map, it will be color-coded according to your seabed colors.

SIM32.DLL

Version Number: 9.0.3.5

Device Name: HYPACK® Generic Simulator

DEVICE SETUP

Position: Logs position data from this device.

Depth: Logs soundings or magnetometer data from this device.

Heading: Logs heading data from this device.

Use for matrix update: Color-codes a matrix based on the data received from this device.

Paper Annotation: Annotates each event on the sounder's paper roll. (See Driver Output.)

DRIVER SETUP

FIGURE 1. Driver Setup

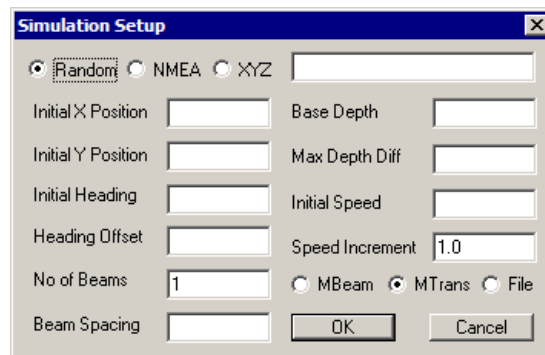

Random: Depths are generated randomly either side of the base depth within the range defined by the Maximum Depth Difference.

Initial X and Y Positions: Enter the coordinates for the position where the vessel should begin the simulation.

Initial Heading: The direction the vessel will travel at the start of the simulation. The Sim32 device window contains controls with which you can turn left and right.

Heading Offset: Number of degrees the vessel is rotated from the direction of travel.

Number of Beams and Beam Spacing: If you are simulating a multibeam or multiple transducer survey, enter the number of beams and the distance between them.

Base Depth: The median depth to be simulated.

Maximum Depth Difference: Depths generated will be: Base Depth +/- Maximum Depth Difference.

Initial Speed: The speed at which the simulated vessel will travel at the start of the simulation.

Speed Increment: The Sim32 device window contains controls with which you can increase/decrease the speed by this amount.

Multibeam simulates a survey with a multibeam transducer. Records ECM records with different depths for each transducer.

Tip:

To simulate a single beam survey, select the multibeam option and set the number of beams to '1'.

Multiple Transducer simulates a survey with multiple transducers. Records ECM records with same depth for each transducer.

File simulates a single beam survey.

DEVICE OUTPUT STRINGS

None. This driver simulates device data.

DRIVER OUTPUT STRINGS

DEVICE WINDOW:

FIGURE 2. Device Window

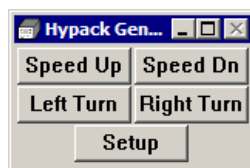

[Speed Up], [Speed Down]: Increments/Decrements the vessel speed by the user-defined Speed Increment.

[Left Turn], [Right Turn]: Modifies the vessel heading.

[Setup]: Accesses the Driver Setup dialog.

SONARWIZ.DLL

Version Number: 9.0.1.2

Device Name: Chesapeake Technologies, Sonar Wiz Output

DEVICE SETUP

Generate Output Messages: (required) custom string.

Paper Annotation: Annotates each event on the sounder's paper roll. (See Driver Output.)

DRIVER SETUP

None

DEVICE OUTPUT STRINGS

N/A

DRIVER OUTPUT STRINGS

DEVICE WINDOW AND SERIAL PORT

- **If logging:**

```
DD/MM/YYYY HH:MM:SS.SS LineName Event# MobileLat  
MobileLon BoatLat BoatLon MobileDepth WaterDepth  
CableLength MobileSpeed MobileSpeed MobileHeading  
LogStatus FileName <CR><LF>
```

- **If not logging:**

```
DD/MM/YYYY HH:MM:SS.ss LineName Event# MobileLat  
MobileLon BoatLat BoatLon MobileDepth WaterDepth  
CableLength MobileSpeed MobileSpeed MobileHeading  
0<CR><LF>
```

EVENTS

Start Logging: "START_LOGGING FileName<CR><LF>"

(If there's no FileName, prints same line without it.)

End Logging: "STOP_LOGGING<CR><LF>"

SPECIAL NOTES

CableLength is read from Shared Memory. This part of shared memory is populated by the Towcable.dll associated with the mobile.

EOL = <LF>

WINDDRIVER.DLL

Version Number: 16.1.2

Device Name: Wind Speed Driver

Reads a comma delimited string from a weather station and displays the absolute wind speed and direction.

DEVICE SETUP

Record device specific messages: Logs additional data related to the device to the Raw file. Each record will be identified by a driver-specific, 3-character tag.

This driver records a WND string to the raw file:

WND DevNumber TimeStamp RawMessage

DRIVER SETUP

FIGURE 1. Driver Setup

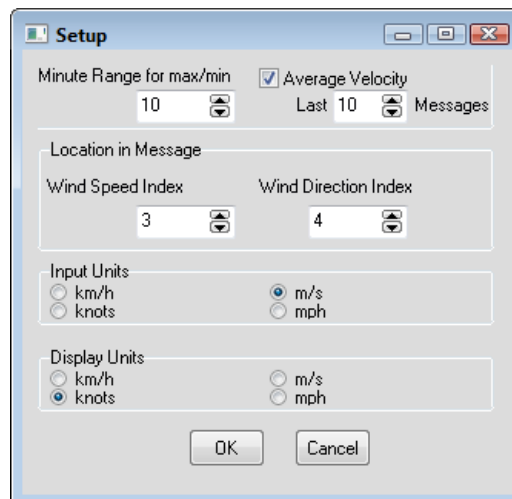

Minute Range for Maximum/Minimum: Time span over which SURVEY determines the Maximum and Minimum wind speed displayed in the device window.

Average Velocity: Select this option and enter the number of records the driver should use to average the wind speed.

Location in Message: Enter which value in the string represents Wind Speed and Wind Direction.

Input Units: Wind speed units in the device output string.

Display Units: Wind speed units for your display.

DEVICE OUTPUT STRINGS

User-configurable driver. Comma-delimited ASCII text.

DRIVER OUTPUT

DEVICE WINDOW:

FIGURE 2. Sample Device Window

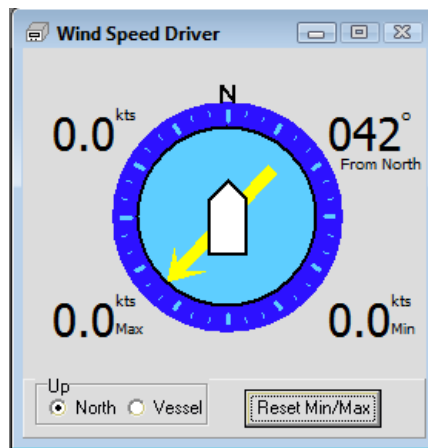

Displays the current wind speed (top left) and direction (top right), and the minimum and maximum speeds over the most recent time span (Minute Range) defined in the driver setup.

Up options determine the orientation of the graphic: North up or Vessel up.

[Reset Min/Max]: Sets the minimum and maximum wind speeds to the current wind speed and begins a new Minute Range over which to track the minimum and maximum wind speeds.

SPECIAL NOTES

User-configurable.

Tip:

Limit the update rate in the Survey Connect tab to something slow enough so you can easily read the text as the values update.