

a xylem brand

### ULTRA-MAX

#### FEATURES

Fully Assembled water pressure set with pump, pressure switch, accumulator tank and Pumpgard™ strainer.

- Ideal for up to four outlets
- All units mounted on one board for rapid and easy installation by boatbuilder and boat owner alike
- Self-priming to 10 ft. (3m)
- Runs dry without damage
- Smooth even flow
- Simple and low cost installation
- Thermal overload protection
- Pressure switch cut-in 20 psi (1.4 bar) cut-out 40 psi (2.8 bar)
- Meets USCG Regulation 183.410 and EN ISO8846 Marine (Ignition Protection)
- Port adapter for 1/2" (13 mm) I.D. hose barb and 1/2"-14 pipe thread fittings
- Flow of 3.8 GPM (14.4 LPM)
- Accumulator tank is pre-pressurized to 20 psi
- Shipping weight 6.6 lb. (3 kg)
- **CE**

#### INSTALLATION INSTRUCTIONS

The Ultra-Max should be bolted securely to a flat surface in any suitable location within the vessel where it remains accessible for routine maintenance, taking care not to over compress the mounting feet. The unit should be installed within the system after the water tank and before the pipeline divides to serve the water heater or other outlets. Connect the supply from the water tank to the inlet port on the Pumpgard™. Connect the outlet plumbing to the discharge port on the Accumulator Tank.

 <b>WARNING</b>	<b>Explosion hazard. Do not pump gasoline, solvents, thinners or other flammable liquids. To do so can cause an explosion resulting in injury or death.</b>
---	---

#### ELECTRICAL CONNECTIONS

Using the table below select the correct cable size. Cable run is the total length of the cable from the positive battery terminal to the pump and back to the negative terminal.

Model No.	Voltage	Amp Draw	Maximum Fuse Size	Cable Length	Minimum Wire Size
59451-1012	12V	8 Amp	12 Amp	10-15 ft. (3-5 m)	12 AWG (2.5 mm <sup>2</sup> )
59451-1024	24V	4 Amp	6 Amp	10-15 ft. (3-5 m)	14 AWG (1.5 mm <sup>2</sup> )

The electrical circuit should be protected with an over current protection device in the positive lead. The red terminal on the board is positive, the black terminal is negative.



Model 59451-1012/24

#### OPERATION INSTRUCTIONS

Check level of water in tank.

Open all faucets hot and cold.

Switch pump on and wait for hot water tank and water lines to fill.

Close each faucet as flow becomes steady and free of air (Close cold water faucet first). Pump should shut off soon after closing last faucet.

Pump is now ready for automatic operation. It will start when faucet is opened and stop when faucet is closed.

If pump will be inoperative for a considerable time, turn off circuit to pump and bleed system by opening a faucet.

It is advisable to run the pump for 2 minutes on first installation to flush fresh water through the pump.

**CAUTION** Motor case will get hot. Prolonged contact during operation may cause a burn.

**CAUTION** Do not overpressurize tank, maximum working pressure is 125 psi (8.6 bar).

## EXPLODED VIEW

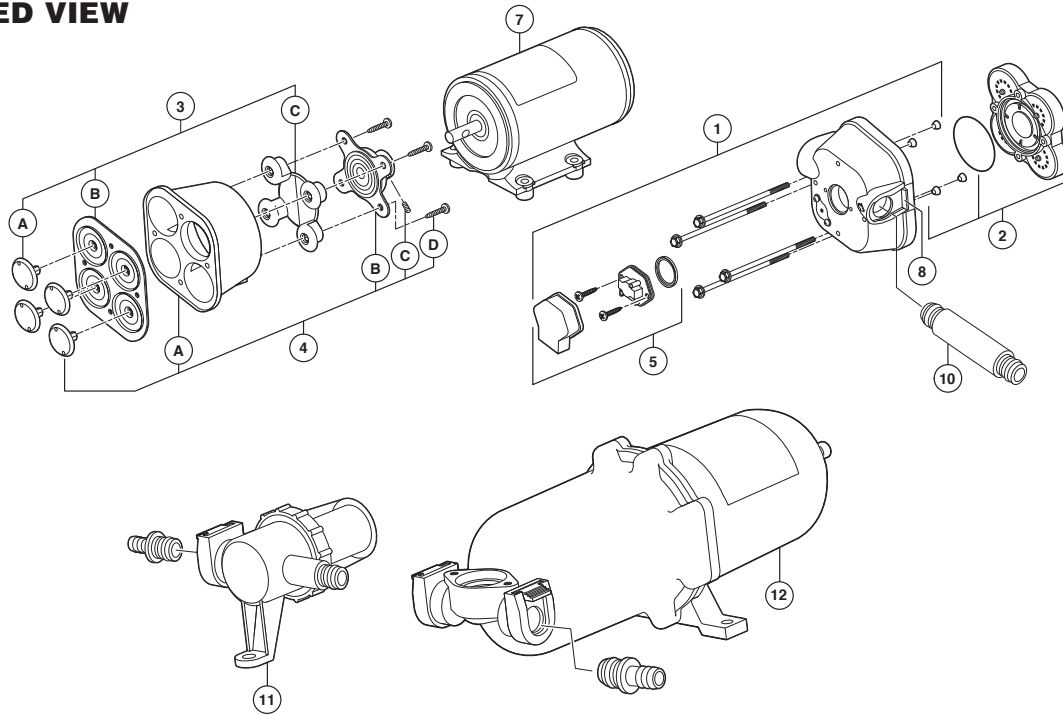

## PARTS LIST

Key	Description	Qty.	Part Number
1	Upper Housing	1	18910-4040
2	Valve Kit	1	18911-4040
3	Diaphragm Kit	1	18910-7030
4	Lower Housing Kit	1	18912-3040
5	Pressure Switch	1	18915-9002
6*	Service Kit	1	18916-0040
7	Motor Kit 12 Volt 24 Volt	1	18919-0150 18919-1067
8	Slide Clip	1	30648-1000
9**	Pumphead Assembly	1	18914-6340
10	Connector Kit	1	59410-1000
11	Pumpgard™ Strainer	1	36400-9000
12	Accumulator Tank	1	30573-0000
13	Mounting Tray (not shown)	1	59411-0000

\* Service Kit includes Keys 2, 3, 4B, 4C, 4D and 8

\*\* Pumphead Assembly includes Keys 1, 2 and 4

THE PRODUCTS DESCRIBED HEREIN ARE SUBJECT TO THE JABSCO THREE YEAR LIMITED WARRANTY, WHICH IS AVAILABLE FOR YOUR INSPECTION UPON REQUEST.

[www.jabSCO.com](http://www.jabSCO.com)

**JabSCO**, 17942 Cowan Irvine, CA 92614  
Tel: +1 949 608 3900 Fax: +1 949 608 3887

**JabSCO**, Bingley Road, Hoddesdon, Hertfordshire, EN11 0BU  
Tel: +44 (0) 1992 450 145 Fax: +44 (0) 1992 467 132

**NHK JabSCO Co Ltd**, 3-21-10, Shin - Yokohama Kohoku-ku, Yokohama 222  
Tel: +81 (0) 45 475 8906 Fax: +81 (0) 45 475 8908

**JabSCO GmbH**, Oststraße 28, 22844 Norderstedt  
Tel: +49 (0) 40 53 53 73 0 Fax: +49 (0) 49 53 53 73 11

**JabSCO Italia, s.r.l.**, Via Tommaseo, 6, 20059 Vimercate, Milano  
Tel: +39 039 685 2323 Fax: +39 039 666 307

USA

UK

JAPAN

GERMANY

ITALY



a xylem brand