

### SELF-PRIMING PUMPS MANUAL CLUTCH UNIT

#### FEATURES

|                         |                           |
|-------------------------|---------------------------|
| <b>Body:</b>            | Bronze                    |
| <b>Impeller:</b>        | Nitrile Compound Standard |
| <b>Shaft:</b>           | Brass                     |
| <b>Ports:</b>           | 1-1/4" NPT                |
| <b>Seal:</b>            | Carbon-Ceramic, Face-Type |
| <b>Bearings:</b>        | Shielded Ball Bearings    |
| <b>Shipping Weight:</b> | 17 lb (7,7 kg)            |

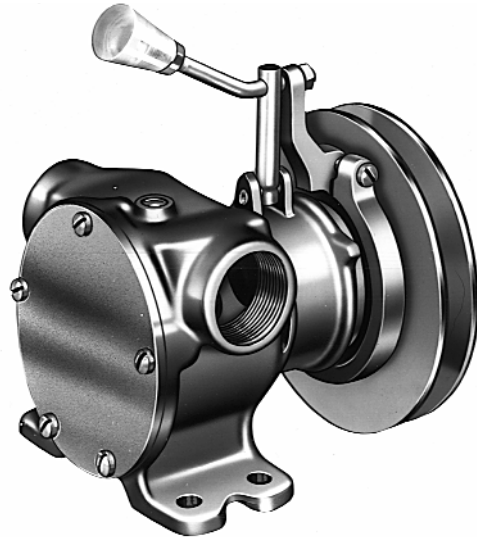

Model 6590-Series

#### APPLICATIONS

**MARINE:** Pumping bilges, Washdowns, Circulating water in bait tanks, Utility dock-side pump.

**INDUSTRIAL:** Circulating and transferring, Velocity-mixing, Pumping machine tool coolants, Return spill, Sump drainage, Chemicals, Pharmaceuticals, Soap, Liquors, Ink, Dyes, Alcohol, Various acids, Tanning Liquors, Glycerine, Brine, etc.

**FARMING:** Pumping water for stock, Pumping water from shallow wells and cisterns.

**PLUMBING & HOME EMERGENCY USE:** Pumping out flooded basements, Cesspools, Sumps, Water heaters and water closets, Drains and sinks, Draining fishponds and pools.

**PUBLIC UTILITIES AND MUNICIPALITIES:** De-watering and draining meter boxes and excavations, Dust Control and sampling

#### OPERATING INSTRUCTIONS

- 1. NOTICE** – Pump must be mounted to run in a clockwise direction when looking at the end cover. Failure to install for clockwise rotation can damage clutch.
- 2. DRIVE BELT** – Overtight belt load will reduce pump bearing and clutch face life. 1/2" deflection of belt midway between pulleys is generally considered normal. Use a B section belt.
- 3. SPEEDS** – 100 RPM to 1750 RPM. Consult factory for operation at speeds above 1750 RPM. For longer pump life, operate at lowest possible speed.
- 4. SELF-PRIMING** – Primes at low or high speed. For vertical dry suction lift of 10 feet, a minimum of 800 RPM is required. Pump will produce suction lifts up to 22 feet when wetted. "Be sure suction connections are airtight or pump will not self prime."

- 5. RUNNING DRY** – Unit depend on liquid pumped to lubrication. Do not run dry for more than 30 seconds. lack of liquid will burn impeller.
- 6. NOTICE** – If pumping light fraction petroleum derivatives, solvents, thinners, highly concentrated or organic acids consult Jabasco Chemical Resistance Table (which is available upon request from Jabasco) for proper body materials and impeller compounds. If corrosive fluids are handled, pump life will be prolonged if pump is flushed with water after each use or after each work day.
- 7. PRESSURES** – Consult Head/Capacity Table for recommended maximum for continuous operation. Consult factory if pressures might exceed those shown.
- 8. TEMPERATURES** – Neoprene impeller—45° to 180°F (7° to 82°C). Nitrile impeller—50° to 180°F (10° to 82°C).
- 9. FREEZING WEATHER** – Loosen and cover screws to drain unit.
- 10. GASKET** – Use standard pump part. Thicker gasket will reduce priming ability—thinner gasket will cause impeller to bind. Standard gasket is 0.015".
- 11. SPARE PARTS** – To avoid costly shutdown, keep a Jabasco Service Kit on hand.

#### WARNING



**Injury hazard. Exposed pulleys and belts can cause injury. Install shield around pulleys and belts. Stay clear while machinery is operating.**

## EXPLODED VIEW

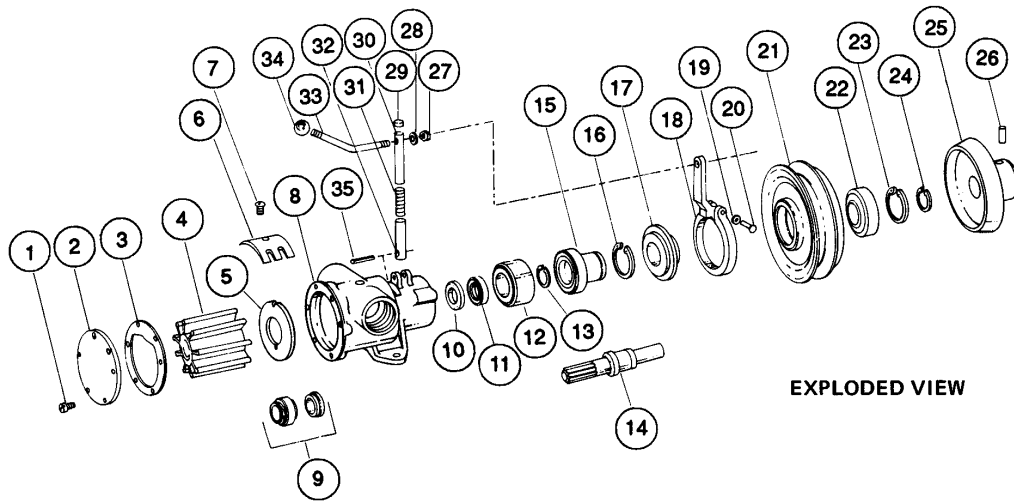

EXPLODED VIEW

## PARTS LIST

| KEY | DESCRIPTION               | QTY. | 6590-SERIES<br>PART NO. |
|-----|---------------------------|------|-------------------------|
| 1   | Screw (End Cover)         | 6    |                         |
|     | Screw (End Cover)         | 5    | 91005-0040              |
| 2   | End Cover                 | 1    | 12062-0000              |
| 3   | *Gasket                   | 1    | 816-0000                |
| 4   | *Impeller Neo. Brass Ins. | 1    | 17935-0001              |
|     | Impeller Nit. Brass Ins.  |      | 836-0003                |
| 5   | Wearplate                 | 1    | 2574-0000               |
| 6   | Cam - Brass               | 1    | 834-0001                |
| 7   | Screw (Cam)               | 1    | 91005-0040              |
| 8   | Body                      | 1    | 18753-0118              |
| 9   | *Seal (Shaft)             | 1    | 6407-0010               |
| 10  | Slinger                   | 1    | 3181-0000               |
| 11  | Seal (Brg.)               | 1    | 817-0000                |
| 12  | Ball Bearing (Pump)       | 1    | 92600-0040              |
| 13  | Ret. Ring (Brg. to Shaft) | 1    | 18711-0000              |
| 14  | Shaft                     | 1    | 824-0010                |
| 15  | Body Plug & Eng. Sleeve   | 1    | 3856-0000               |
| 16  | Ret. Ring (Plug to Body)  | 1    | 18712-0000              |
| 17  | Adaptor Ring              | 1    | 2471-0000               |
| 18  | Lever Ring                | 1    | 2470-0000               |

| KEY | DESCRIPTION                   | QTY. | 6590-SERIES<br>PART NO. |
|-----|-------------------------------|------|-------------------------|
| 19  | Lock Washer (Lever Ring)      | 1    | 91602-0060              |
| 20  | Screw (Lever Ring)            | 1    | 91005-0060              |
| 21  | Clutch Pulley                 | 1    | 2472-0010               |
| 22  | Ball Bearing (Pulley)         | 1    | 92600-0330              |
| 23  | Ret. Ring (Brg. to Clutch)    | 1    | 18718-0000              |
| 24  | Ret. Ring (Brb. to Sleeve)    | 1    | 18707-0000              |
| 25  | Clutch Cone                   | 1    | 2473-0000               |
| 26  | Roll Pin (Cone)               | 1    | 93100-0010              |
| 27  | Hex Nut (Handle)              | 1    | 91085-0090              |
| 28  | Lock Washer (Handle)          | 1    | 91602-0080              |
| 29  | Plug (Rubber)                 | 1    | 3530-0000               |
| 30  | Spring Guide Tube             | 1    | 3525-0000               |
| 31  | Spring (Handle)               | 1    | 3528-0000               |
| 32  | Guide Tube                    | 1    | 3526-0000               |
| 33  | Handle (Clutch)               | 1    | 2415-0000               |
| 34  | Knob (Handle)                 | 1    | 92330-0010              |
| 35  | Roll Pin (Tube)               | 1    | 93100-0020              |
|     | Clutch Kit (Keys No. 15-34)   |      | 4387-0000               |
|     | Service Kit Neoprene Impeller |      | 90062-0001              |
|     | Service Kit Nitrile Impeller  |      | 90062-0003              |

\* Parts Supplied with Service Kit.

## SERVICE INSTRUCTIONS

**Impeller Replacement:** Remove end cover gasket. Pull impeller out by grasping hub with pliers. With a rotary motion in the direction the pump will be turning, push the new impeller into the impeller bore. A light coating of grease in the impeller bore will protect the impeller during initial dry start up. Install gasket and end cover.

**Shaft Seal Replacement:** Remove end cover, gasket and impeller as outlined above. Loosen cam screw several turns and give it a couple of sharp raps with the handle of the screwdriver to loosen the cam from the impeller bore. Remove the cam screw and cam (clean sealant from cam and impeller bore). Remove wearplate with hooked wire.

In this pump, either a wave washer seal or coil spring seal may be used. The wave washer is used only if the carbon portion of the seal does not have a coil spring attached.

Using a hooked wire, and taking care not to scratch shaft or seal seat bore, remove all components of seal assembly. Inspect shaft and seal seat bore to be sure sealing surfaces are free of nicks or scratches. Clean shaft surface behind splines to insure proper O-ring seal on shaft.

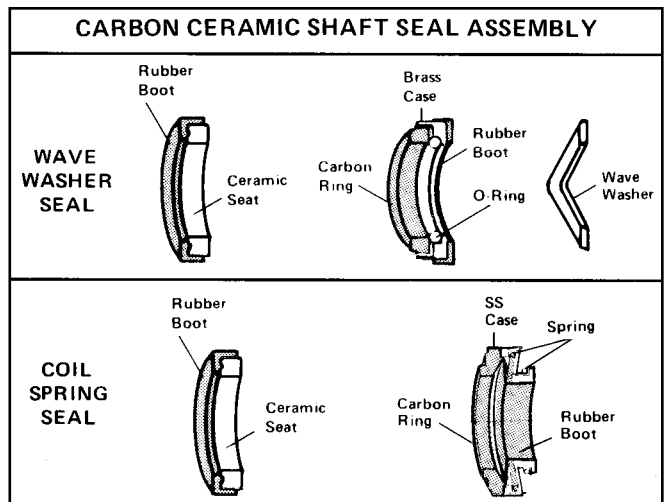

Apply light film of grease on shaft surface behind spline area. Thoroughly clean seal faces (carbon and ceramic) of all grease, oil or particles—this will insure that seal faces will turn freely on startup. Place ceramic seat assembly in body with boot first. Use care not to damage ceramic surface. Be sure ceramic and boot are bottomed squarely in body bore. Slide carbon ring assembly, with carbon facing ceramic, over the shaft and firmly up against the ceramic seat. If carbon portion of seal does not have an integral coil type tensioning spring, slide wave washer over the shaft and against the rubber boot on metal case containing O-ring and carbon. Replace wearplate aligning notch with dowel pin in body. Apply sealant to top surface of cam and cam screw threads and install cam in impeller bore. Snug up but do not tighten cam screw. Replace impeller, gasket and end cover as outlined above. Tighten end cover screws. Tighten cam screw.

**Clutch Adjustment for Wear (Clutch Slippage):** The Jabsco clutch engages and disengages by means of internal threads in the body plug and external threads on the engaging sleeve. When adjustment is made, the engaging sleeve is “backed out” of the body plug. Therefore, the adjustment is limited to the position beyond which the threads are not sufficiently engaged to provide a sturdy support for the belt load. If over-adjustment is made, the pulley wobbles and causes more wear and slippage. The following procedure is recommended.

- A. Move the clutch handle to fully engaged position (on the extreme left when looking at the pulley end of unit). If there is a rubber ring gasket between the lever ring and body, pry it out and discard it.
- B. Loosen screw (key 17) on lever ring (key 15).
- C. Hold adaptor ring (key 14) in place with a screwdriver to prevent it from turning and simultaneously rotate lever ring to the right, towards the disengaged position, approximately half way between the left hand stop lug and the center line of the pump (the lever ring will slide on the adaptor ring more easily if a screwdriver is used to hold the split in the lever ring apart).
- D. Tighten lever ring screw, and check to see if clutch is engaged when handle is moved to the left as far as it will go.
- E. Repeat if necessary. However, if it becomes necessary to move lever ring more than twice (1-1/2" or 45° from its original position on the adaptor ring) the cone is badly worn and should be replaced to prevent damage to the engaging sleeve and body plug threads.

## MAJOR REPAIR

Remove pump from installation for major repair.

**Clutch Replacement:** Remove roll pin (key 23) from clutch cone (key 22). Using a wheel puller, grip notches in clutch cone and pull it from the shaft. Remove clutch handle (key 33) spring guide tube (key 30) and spring (key 29). The pulley, bearing, engaging sleeve, adaptor ring and lever ring are removed by unscrewing the engaging sleeve from the body plug as follows:

1. Facing the pulley end of the pump, turn lever ring (key 15) counterclockwise (left to the stop lug on body).
2. Loosen screw (key 17) on lever ring.
3. Hold the engaging sleeve in place with a screwdriver placed between shaft and engaging sleeve and simultaneously rotate lever ring clockwise (right) to the opposite stop lug on body.
4. Tighten screw.
5. Repeat above steps until engaging sleeve is unscrewed and pulley assembly comes loose from the pump. Individual parts may be replaced in the pulley and clutch mechanism or the complete clutch may be replaced using clutch kit.

**NOTE:** To assist in repairs the clutch kit contains the adaptor ring, ball bearing and pulley pressed on to the engaging sleeve with retaining rings in place and the lever ring assembled to the adaptor ring. The body plug and engaging sleeve are selective fit and should be replaced as a set. Remove retaining ring (key 13) from body. Remove retaining ring (key 21) from engaging sleeve. Support pulley assembly on adaptor ring and press engaging sleeve out of pulley bearing and adaptor ring.

Use the engaging sleeve to remove the body plug by threading the engaging sleeve into the body plug and using a pipe wrench to force the body plug away from the bearing and out of the body. To assemble the clutch kit to the pump, remove the body plug from the engaging sleeve and press it into the bearing bore firmly against ball bearing. Install retaining ring in body with flat side against body plug. Grease threads of body plug. Place assembled pulley, bearing, engaging sleeve and lever ring mechanism over shaft and against body plug. With lever ring in the “up” position, rotate lever ring clockwise to start threads of engaging sleeve into body plug. Thread engaging sleeve into body plug as follows:

1. Facing pulley end of the pump, turn lever ring clockwise (right) to the stop on the body.
2. Loosen Screw on lever ring.
3. Hold engaging sleeve in place with a screwdriver placed between the engaging sleeve and shaft, and simultaneously rotate lever ring counterclockwise (left) to the stop on the body.
4. Tighten screw in the lever ring.
5. Repeat above steps until engaging sleeve is completely threaded in body plug. With engaging sleeve threaded and bottomed in body plug, loosen screw in lever ring and rotate lever ring clockwise to stop on body. Tighten lever ring screw. Rotate lever ring counterclockwise and hold in place 15 degrees to the left of top center. Slide clutch cone onto shaft and push it tight against pulley. With pilot hole at 90° to hole in shaft and using pilot hole in clutch cone hub as a guide, drill 3/16" (4,76 mm) diameter hole through the shaft and straight through the clutch cone hub. Insert roll pin into drilled hole. With clutch fully engaged, lever ring should be approximately 30 degrees to the left of top center (facing pulley end of pump). Check clutch engagement and perform any required adjustments using the “clutch adjustment” procedure. Install control handle hardware.

## SHAFT & BEARING REPLACEMENT

Remove pump from installation for major repair.

**Disassembly:** Remove end cover, impeller, cam, wearplate and seal as outlined in “shaft seal replacement” instructions. Remove retaining ring from body. Support body on arbor press platen and press on impeller end of shaft to remove the body plug and bearing/shaft assembly from body. Slinger can be removed through drain slot. Use a screwdriver to pry inner bearing seal from bearing bore. Check condition of bearing and shaft. Replace if bearing turns roughly or has grating feel. Replace shaft if worn in seal area or if splines are worn. Remove retaining ring from shaft and press on clutch end of shaft with supporting bearing inner race.

**Assembly:** Support inner race of ball bearing, insert clutch drive end of shaft through bearing, press on splined end until bearing is seated firmly against shaft shoulder. Install retaining ring on shaft. Lubricate bearing seal and press body bearing bore with lip facing impeller end. Place slinger in drain slot and insert splined end of shaft into bearing bore, through bearing seal and press on outer race of bearing until bearing bottoms firmly against shoulder in body. Center slinger in drain area. Press body plug into body firmly against bearing. Install retaining ring in body with flat side against body plug. Dip in water and push carefully over shaft splines with gasket side down until it bottoms firmly against shaft shoulder. With carbon face of seal towards ceramic seal seat, locate seal squarely in seal bore and using a tube of suitable diameter to press on outside edge of seal, press seal bore flush with bottom face of impeller bore. Install wearplate, can, impeller gasket and end cover as outlined in “seal replacement” instructions.

When installing pump, do not overtighten belt. Belt tension is normally considered sufficient when belt can be depressed 1/2" midway between pulleys. Over tight belt can cause wear between clutch cone and pulley.

## DIMENSIONAL DRAWING

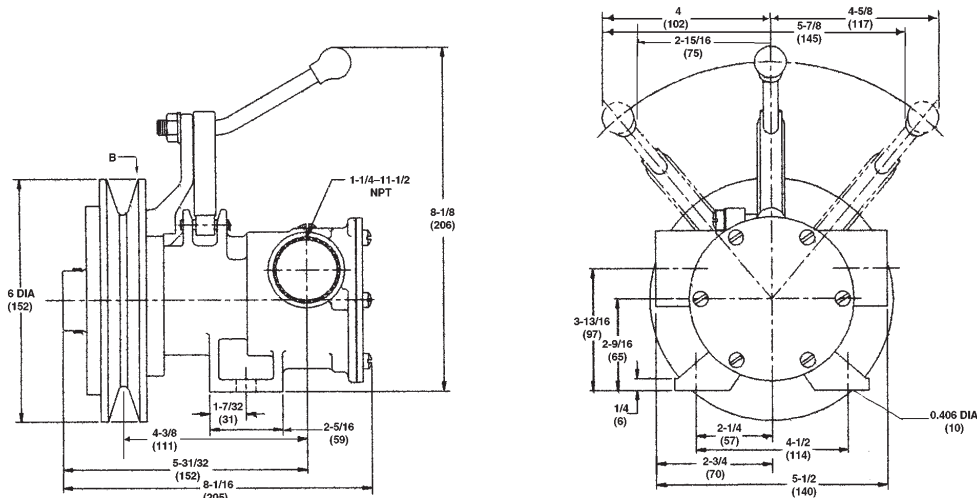

TABULATIONS FOR ABOVE MODEL Inches (Millimeters)

| Model       | A               | B              | C                | D              | E               | F                   | G               | H              | I             | J              | K              | L                   | M                     |
|-------------|-----------------|----------------|------------------|----------------|-----------------|---------------------|-----------------|----------------|---------------|----------------|----------------|---------------------|-----------------------|
| 6590-Series | 8-1/16<br>(205) | 8-1/8<br>(206) | 5-31/32<br>(152) | 4-3/8<br>(111) | —               | —                   | 1-7/32<br>(31)  | 2-5/16<br>(59) | 2-1/4<br>(57) | 4-1/2<br>(114) | 2-3/4<br>(70)  | 5-1/2<br>(140)      | 0.406<br>Dia.<br>(10) |
| Model       | N               | O              | P                | Q              | R               | S (Port Size)       | T               | U              | V             | W              | X              | Y (Drive Belt Size) |                       |
| 6590-Series | 1/4<br>(6)      | 2-9/16<br>(65) | 3-13/16<br>(97)  | 5-7/8<br>(149) | 2-15/16<br>(75) | 1-1/4-11-1/2<br>NPT | 6 Dia.<br>(152) | 13/16<br>(21)  | 1-1/2<br>(38) | 4<br>(102)     | 4-5/8<br>(117) | B                   |                       |

## HEAD / CAPACITY TABLE

|                    | Total Head |              |               |                 | 500 RPM |       |     | 1160 RPM |       |       | 1750 RPM |       |       |
|--------------------|------------|--------------|---------------|-----------------|---------|-------|-----|----------|-------|-------|----------|-------|-------|
|                    | psi        | kg per sq cm | feet of water | meters of water | GPM     | L/Min | HP  | GPM      | L/Min | HP    | GPM      | L/Min | HP    |
| <b>6590-Series</b> | 4.3        | 0,3          | 10            | 3,0             | 18      | 68,1  | 1/2 | 41       | 155,2 | 1     | 62       | 234,7 | 1-1/2 |
|                    | 8.7        | 0,6          | 20            | 6,1             | 17      | 64,3  | 1/2 | 40       | 151,4 | 1     | 60       | 227,1 | 1-1/2 |
|                    | 17.3       | 1,2          | 40            | 12,2            | 14      | 53,0  | 1/2 | 37       | 140,0 | 1-1/2 | 55       | 208,2 | 2     |
|                    | 26.0       | 1,8          | 60            | 18,3            | —       | —     | —   | 32       | 121,1 | 1-1/2 | 50       | 189,3 | 2     |
|                    | 34.6       | 2,4          | 80            | 24,4            | —       | —     | —   | —        | —     | —     | 44       | 166,5 | 3     |



**xylem**  
Let's Solve Water

[www.xyleminc.com](http://www.xyleminc.com)

**UK**  
**Xylem**  
Bingley Road, Hoddesdon  
Hertfordshire EN11 0BU  
Tel: +44 (0) 1992 450145  
Fax: +44 (0) 1992 467132

**USA**  
**Xylem**  
100 Cummings Center Drive  
Suite 535-N, Beverly, MA 01915  
Tel: +1 978 281-0440  
Fax: +1 978 283-2619

**ITALY**  
**Xylem**  
Via Tommaseo, 6  
20059 Vimercate, Milano  
Tel: +39 039 685 2323  
Fax: +39 039 666 307

**GERMANY**  
**Xylem**  
Oststrasse 28  
22844 Norderstedt  
Tel: +49-40-53 53 73-0  
Fax: +49-40-53 53 73-11

**JAPAN**  
**Xylem**  
3-21-10, Shin-Yokohama  
Kohoku-Ku, Yokohama, 222-0033  
Tel: +81-045-475-8906  
Fax: +81-045-477-1162

**Warranty:** All products of the company are sold, and all services of the company are offered subject to the company's warranty and terms of sale, copies of which will be furnished upon request. Details correct at time of printing. We reserve the right to change specifications without prior notice.