

e-SV Series SPECIAL VERSIONS

ErP 2009/125/CE

Xylect

Xylect is a pump selection software with an extensive online database of product information across the entire range of pumps and related products, with multiple search options and helpful project management facilities. The system holds up-to-date product information on thousands of products and accessories.

Xylect is available:
On the website – www.xylect.com

For more information, please, see page 219-220.



Ecodesign Directive 2009/125/CE

The **Directive 2005/32/EC** on energy-using products (**EuP**) and the subsequent **Directive 2009/125/EC** on energy-related products (**ErP**) established the ecodesign requirements for products to reduce their energy consumption and consequently their environmental impact.

These requirements apply to products placed and used in the European Economic Area (European Union plus Iceland, Liechtenstein and Norway) as a stand-alone unit or as integrated parts in other products.

The table shows the Regulations that define the requirements for Lowara products:

Product	Regulations	From	Target
Pumps*	(EU) N. 547/2012	1 January 2015	MEI ≥ 0,4
Circulators**	(EC) N. 641/2009, (EU) N. 622/2012 e (EU) 2019/1781	1 August 2015	EEI < 0,23
Electric motors	(EU) 2019/1781 e 2021/341	1 July 2021	IE2 : three-phase motors with a rated output ≥ 0,12 and < 0,749 kW IE3 : three-phase motors with a rated output ≥ 0,75 and < 1000 kW
Variable speed drives (VSD)***	(EU) 2019/1781 e 2021/341	1 July 2021	IE2

* some types of pump, used for pumping clean water.

** circulators with a rated hydraulic output power of between 1 and 2500 W, designed for use in heating systems or in secondary circuits of cooling distribution systems.

*** variable speed drives with three-phase input and rated output power from 0,12 kW up to 1000 kW, rated for operating with motor included in the same regulations.

From 1 July 2023 it will be introduced additional requirements.

CONTENTS

INTRODUCTION	5
COMPATIBILITY MATRIX	7
PUMPS (ErP 2009/125/EC).....	8
ELECTRIC PUMP CROSS SECTION AND MAIN COMPONENTS.....	9
MECHANICAL SEALS, ACCORDING TO EN 12756.....	13
HIGH PRESSURE (50/60 Hz)	15
TECHNICAL CHARACTERISTICS	17
BALANCED MECHANICAL SEALS, ACCORDING TO EN 12756.....	18
DIMENSIONS AND WEIGHTS AT 50 Hz, 2-POLE	20
OPERATING CHARACTERISTICS AT 50 Hz, 2-POLE	21
DIMENSIONS AND WEIGHTS AT 60 Hz, 2-POLE	42
OPERATING CHARACTERISTICS AT 60 Hz, 2-POLE	43
LOW NPSH (50/60 Hz)	65
TECHNICAL CHARACTERISTICS	68
IDENTIFICATION OF GRAPH	69
DIMENSIONS AND WEIGHTS AT 50 Hz, 2-POLE	70
OPERATING CHARACTERISTICS AT 50 Hz, 2-POLE	71
DIMENSIONS AND WEIGHTS AT 60 Hz, 2-POLE	90
OPERATING CHARACTERISTICS AT 60 Hz, 2-POLE	91
HIGH TEMPERATURE ...150°C (50/60 Hz)	109
ELECTRIC PUMP CROSS SECTION AND MAIN COMPONENTS.....	112
BALANCED MECHANICAL SEALS, ACCORDING TO EN 12756.....	114
DIMENSIONS AT 50/60 Hz	115
HIGH TEMPERATURE "BOILER" ...180°C (50/60 Hz)	117
ELECTRIC PUMP CROSS SECTION AND MAIN COMPONENTS.....	120
BALANCED MECHANICAL SEALS, ACCORDING TO EN 12756.....	122
DIMENSIONS AT 50/60 Hz	123

4-POLE VERSIONS (50/60 Hz)	125
DIMENSIONS AND WEIGHTS AT 50 Hz, 4-POLE	130
OPERATING CHARACTERISTICS AT 50 Hz, 4-POLE	131
DIMENSIONS AND WEIGHTS AT 60 Hz, 4-POLE	156
OPERATING CHARACTERISTICS AT 60 Hz, 4-POLE	157
REDUCED OVERALL DIMENSIONS (50/60 Hz).....	179
HORIZONTAL INSTALLATION (50/60 Hz)	183
MOTORS (50/60 Hz)	189
MOTORS AT 50 Hz (ErP 2009/125/EC)	190
MOTORS AT 60 Hz (ErP 2009/125/EC)	195
REPORTS AND DECLARATIONS.....	201
ACCESSORIES	203
TECHNICAL APPENDIX.....	213

INTRODUCTION

e-SV SERIES - SPECIAL VERSIONS

Introduction

Our customers are central to our business.

Many years of collaboration with them across the different markets and all over the world has taught us that specifically designed pumps are required to handle special applications or to fulfill particular installations. It is essential to ensure top performance of the systems and continuous quality of the production.

Therefore Lowara has developed a wide range of special versions of its vertical multistage e-SV to give an appropriate and dedicated solution to special applications and installations in the industry or in the building services market.

Pump design

Non-self priming, vertical multistage, high pressure centrifugal pump, with suction inlet and outlet of the same identical nominal diameters, coupled to a standard motor. Horizontal installation also available, see specific section.

Drive

Without speed control: Short circuit squirrel cage motor, totally enclosed, fan-cooled (TEFC), three-phase, 2 and 4 poles, efficiency class **IE2** (0,12-0,749 kW), **IE3** (three-phase 0,75 to 1000 kW). (IEC 60034-30). Single-phase version up to 2,2 kW (built-in automatically resettable overload protection up to 1,5 kW).

With HYDROVAR™ speed control system: A special version of e-SV which becomes an intelligent, variable speed system. Ideal for single pumping solution or multiple pumping set solution (up to 8 pumps).

With e-SM drive speed control system: e-SV Smart series is equipped with an intelligent control that optimizes hydraulic performance while minimizing waste. Ideal for single pumping solution or multiple pumping set solution (up to 3 pumps).

Consult the specific section for further motor options.



Special versions and options index

The first part of this booklet will cover the following special versions:

- High Pressure
- Low NPSH
- High Temperature (150°C)
- High Temperature (180°C)
- 4-pole version
- Reducing footprint
- Horizontal Installation

The second part of this booklet will cover the following sections:

- Motors configuration and standard options
- Protection sensor against dry running
- Reports and declarations
- Accessories

Documentation and support

Pump selection software, visit:

<http://www.xylect.com>

Documentation is also available on:

<https://www.xylem.com/en-uk/brands/lowara/>

Visit us for information including video, commercial leaflet, brochure, other technical catalogues, 2D and 3D drawings, IOM.

e-SV SERIES - SPECIAL VERSIONS COMPATIBILITY MATRIX

The two highlighted digits identify the version (**F** = version, **L** = special version):

22SV0**FL**110T

The following table describes the recommended compatibility between the special versions of e-SV.

Material: AISI 304

Round flanges (PN25) - F

	H	B	L	E	L+E
H	FH	-	FW	-	-
B		-	-	-	-
L			FL	-	-
E				FE*	-

Oval flanges (PN25) - T

	H	B	L	E	L+E
H	-	-	-	-	-
B		-	-	-	-
L			TL*	-	-
E				TE*	-

**Discharge port above suction,
round flanges (PN 25) - R**

	H	B	L	E	L+E
H	RH*	-	-	-	-
B		-	-	-	-
L			RL	-	-
E				RE*	-

Legend

H = High temperature version (150°C)

B = High temperature version (180°C)

L = Low NPSH version

E = Passivated and electropolished version

L+E = Low NPSH version, passivated and electropolished version

* = Customizable, feasible as custom product

- = Not feasible

The following table describes the electrical and positioning possible configuration mix:

High temperature version (150°C) - H

	Hydrovar	e-SM drive	Horizontal	4 poles
Hydrovar	Y	N	*	N
e-SM drive		N	N	N
Horizontal			*	N
4 poles				N

High temperature version (180°C) - B

	Hydrovar	e-SM drive	Horizontal	4 poles
Hydrovar	Y	N	N	N
e-SM drive		N	N	N
Horizontal			N	N
4 poles				N

Material: AISI 316

Round flanges (PN25) - N

	H	B	L	E	L+E
H	NH	-	NW	NI	NA
B		NB	NY	NS	ND
L			NL	NU	-
E				NE	-

Victaulic Couplings (PN25) - V

	H	B	L	E	L+E
H	-	-	-	-	-
B		-	-	-	-
L			VL*	VU	-
E				VE	-

High Pressure Victaulic Couplings (PN 40) - P

	H	B	L	E	L+E
H	-	-	-	-	-
B		-	-	-	-
L			PL*	PU	-
E				PE	-

Clamp Couplings DIN 3676 (PN 25) - C

	H	B	L	E	L+E
H	-	-	-	-	-
B		-	-	-	-
L			CL*	CU	-
E				CE	-

Threaded Couplings DIN 11851 (PN 25) - K

	H	B	L	E	L+E
H	-	-	-	-	-
B		-	-	-	-
L			KL*	KU	-
E				KE	-

Low NPSH version - L

	Hydrovar	e-SM drive	Horizontal	4 poles
Hydrovar	Y	N	Y	Y
e-SM drive		Y	Y	N
Horizontal			Y	Y
4 poles				Y

Passivated and electropolished version - E

	Hydrovar	e-SM drive	Horizontal	4 poles
Hydrovar	Y	N	Y	Y
e-SM drive		Y	Y	N
Horizontal			Y	Y
4 poles				Y

As a global supplier, Lowara can design specific solutions according to the requirements of the application or of the installation. For example, Lowara's custom-built solutions can handle more aggressive liquids or heavy duty applications. For more information, refer to the sales network.

e-SV SERIES PUMPS (ErP 2009/125/EC)

With the “Energy using Products” (EuP 2005/32/EC) and “Energy related Products” (ErP 2009/125/EC) directives, the European Commission has established requirements for promoting the use of products with low power consumption.

Among the various products considered there are also some typologies of pumps with the characteristics defined by the specific **Regulation (EU) n. 547/2012** implementing the requirements of Directives EuP and ErP.

For vertical multi-stage pumps (MS-V for the Regulations), the efficiency evaluation refers to:

- just the pump and not the pump and motor assembly (electric or combustion);
- pumps with a nominal pressure PN not higher than 25 bar (2500 kPa);
- pumps designed to operate at a speed of 2900 min⁻¹ (for electric pumps this means 50 Hz 2-pole electric motors);
- pumps with a maximum flow of 100 m³/h;
- use with clean water at a temperature ranging from -10°C to 120°C (the test is performed with cold water at a temperature not higher than 40°C).

The Regulation also establishes the following deadlines:

from	minimum efficiency index (MEI)
1st January 2015	MEI ≥ 0,4

Regulation (EU) n. 547/2012 – Annex II – point 2 (Product information requirements)

1) Minimum efficiency index (50 Hz):

- e-SV High Pressure: not included in the sphere of application of the Regulations.
- e-SV Low NPSH: see the MEI column in the tables in the *Weights and dimensions at 50 Hz, 2 poles* section.
- e-SV High Temperature (...150°C or ...180°C): see the MEI column in the tables in the *Hydraulic Performance at 50 Hz, 2 poles* section.
- e-SV 4-pole version: not included in the sphere of application of the Regulations.
- e-SV Reducing Footprint: see the MEI column in the table in the *Hydraulic performance at 50 Hz, 2 poles* section.
- e-SV Horizontal installation: see NOTE (50 Hz) in the *Operating characteristics* section.

2) “The benchmark for most efficient water pumps is MEI ≥ 0,70”.

3) Year of manufacture: from January 2013.

4) Manufacturer: Xylem Service Italia srl - Reg. No. 07520560967 - Montecchio Maggiore, Vicenza, Italy.

5) Product type identification:

- e-SV High Pressure: not included in the sphere of application of the Regulations.
- e-SV Low NPSH: see the PUMP TYPE column in the tables in the *Weights and dimensions at 50 Hz, 2 poles* section.
- e-SV High Temperature (...150°C or ...180°C): see the PUMP TYPE column in the tables in the *Hydraulic Performance at 50 Hz, 2 poles* section.
- e-SV 4-pole version: not included in the sphere of application of the Regulations.
- e-SV Reducing Footprint: see the PUMP TYPE column in the table in the *Hydraulic Performance at 50 Hz, 2 poles* section.
- e-SV Horizontal Installation: see the NOTE (50 Hz) in the *Operating characteristics* section.

6) Hydraulic pump efficiency with trimmed impeller: not applicable to these products.

7) Pump performance curves, including the performance curve:

- e-SV High Pressure: not included in the sphere of application of the Regulations.
- e-SV Low NPSH: see the *Operating Characteristics at 50 Hz, 2 poles* graphs.
- e-SV High Temperature (...150°C or ...180°C): see the table in the *Hydraulic Performance at 50 Hz, 2 poles* section.
- e-SV 4-pole version: not included in the sphere of application of the Regulations.
- e-SV Reducing Footprint: see the table in the *Hydraulic Performance at 50 Hz, 2 poles* section.
- e-SV Horizontal Installation: see the NOTE (50 Hz) in the *Operating characteristics* section.

8) “The efficiency of a pump with a trimmed impeller is usually lower than that of a pump with the full impeller diameter. The trimming of the impeller will adapt the pump to a fixed duty point, leading to reduced energy consumption. The minimum efficiency index (MEI) is based on the full impeller diameter”.

9) “The operation of this water pump with variable duty points may be more efficient and economic when controlled, for example, by the use of a variable speed drive that matches the pump duty to the system”.

10) Information relevant for disassembly, recycling or disposal at end-of-life: observe the current laws and by-laws governing sorted waste disposal. Consult the product operating manual.

11) “Designed for use below – 10 °C only”: note not applicable to these products.

12) “Designed for use above 120 °C only”: note not applicable to these products.

13) Specific instructions for pumps as per points 11 and 12: not applicable to these products.

14) “Information on benchmark efficiency is available at”: www.europump.org (Ecodesign section).

15) The benchmark efficiency graphs with MEI = 0.7 and MEI = 0.4 are available at www.europump.org/efficiencycharts (refer to “Multistage Vertical 2900 rpm”).

1, 3, 5SV SERIES and 10, 15, 22SV SERIES ≤ 4 kW
ELECTRIC PUMP CROSS SECTION AND MAIN COMPONENTS

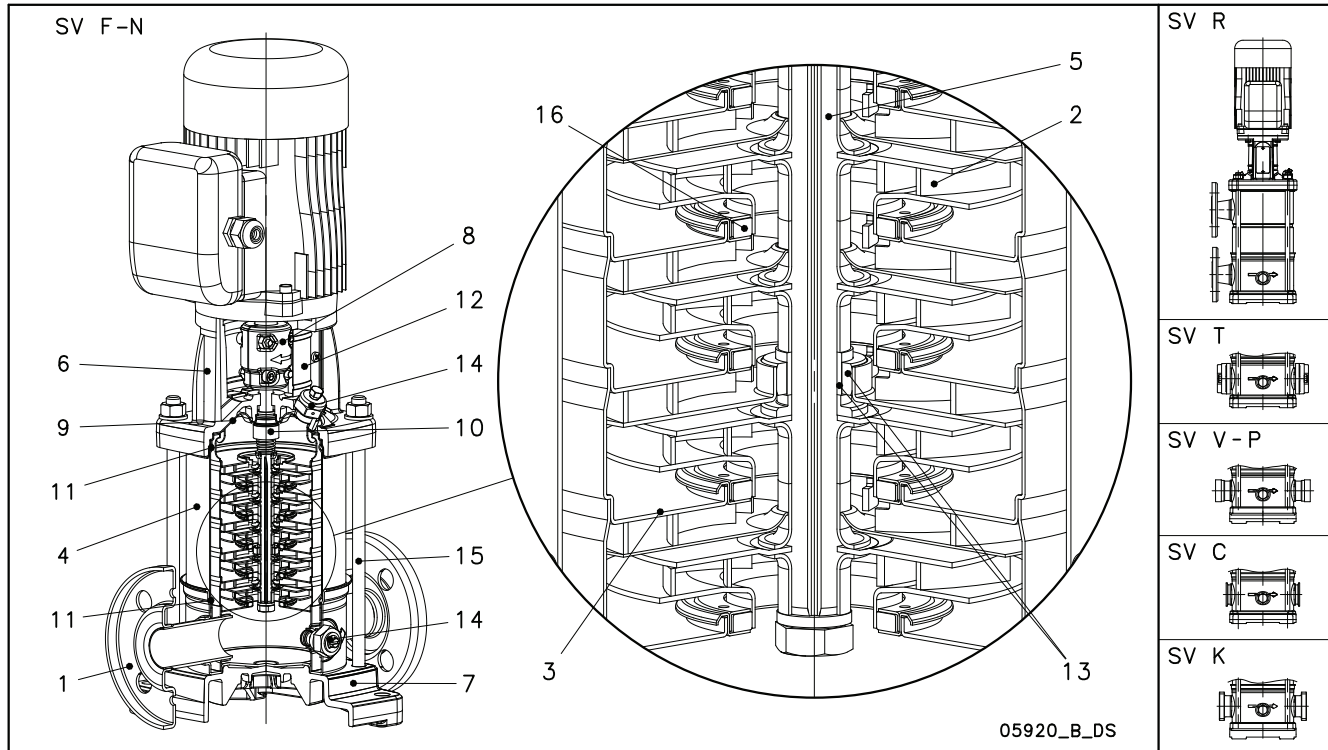

F, T, R VERSIONS

REF. N.	NAME	MATERIAL	REFERENCE STANDARDS	
			EUROPE	USA
1	Pump body	Stainless steel	EN 10088-1-X5CrNi18-10 (1.4301)	AISI 304
2	Impeller	Stainless steel	EN 10088-1-X5CrNi18-10 (1.4301)	AISI 304
3	Diffuser	Stainless steel	EN 10088-1-X5CrNi18-10 (1.4301)	AISI 304
4	Outer sleeve	Stainless steel	EN 10088-1-X5CrNi18-10 (1.4301)	AISI 304
5	Shaft	Stainless steel	EN 10088-1-X5CrNi18-10 (1.4301)	AISI 304
6	Adapter	Cast iron	EN 1561-GJL-250 (JL1040)	ASTM Class 35
7	Base	Aluminium	EN 1706-AC-AISI11Cu2 (Fe) (AC46100)	-
8	Coupling	Aluminium	EN 1706-AC-AISI11Cu2 (Fe) (AC46100)	-
9	Seal housing	Stainless steel	EN 10088-1-X5CrNi18-10 (1.4301)	AISI 304
10	Mechanical seal	Silicon carbide / Carbon / EPDM		
11	Elastomers	EPDM		
12	Coupling protection	Stainless steel	EN 10088-1-X5CrNi18-10 (1.4301)	AISI 304
13	Shaft sleeve and bushing	Tungsten carbide		
14	Fill / drain plugs	Stainless steel	EN 10088-1-X5CrNi18-10 (1.4301)	AISI 304
15	Tie rods	Galvanized steel	EN 10277-3-36SMnPb14 (1.0765)	
16	Wear ring	Technopolymer PPS		

N, V, C, K VERSIONS

1-22sv-frm-en_a_tm

REF. N.	NAME	MATERIAL	REFERENCE STANDARDS	
			EUROPE	USA
1	Pump body	Stainless steel	EN 10088-1-X2CrNiMo17-12-2 (1.4404)	AISI 316L
2	Impeller	Stainless steel	EN 10088-1-X2CrNiMo17-12-2 (1.4404)	AISI 316L
3	Diffuser and upper spacer	Stainless steel	EN 10088-1-X2CrNiMo17-12-2 (1.4404)	AISI 316L
4	Outer sleeve	Stainless steel	EN 10088-1-X2CrNiMo17-12-2 (1.4404)	AISI 316L
5	Shaft	Stainless steel	EN 10088-1-X5CrNiMo17-12-2 (1.4401)	AISI 316
6	Adapter	Cast iron	EN 1561-GJL-250 (JL1040)	ASTM Class 35
7	Base	Aluminium	EN 1706-AC-AISI11Cu2 (Fe) (AC46100)	-
8	Coupling	Aluminium	EN 1706-AC-AISI11Cu2 (Fe) (AC46100)	-
9	Seal housing	Stainless steel	EN 10088-1-X2CrNiMo17-12-2 (1.4404)	AISI 316L
10	Mechanical seal	Silicon carbide / Carbon / EPDM		
11	Elastomers	EPDM		
12	Coupling protection	Stainless steel	EN 10088-1-X5CrNi18-10 (1.4301)	AISI 304
13	Shaft sleeve and bushing	Tungsten carbide		
14	Fill / drain plugs	Stainless steel	EN 10088-1-X5CrNiMo17-12-2 (1.4401)	AISI 316
15	Tie rods	Stainless steel	EN 10088-1-X17CrNi16-2 (1.4057)	AISI 431
16	Wear ring	Technopolymer PPS		

1-22sv-nvck-en_a_tm

10, 15, 22SV SERIES ≥ 5,5 kW

ELECTRIC PUMP CROSS SECTION AND MAIN COMPONENTS

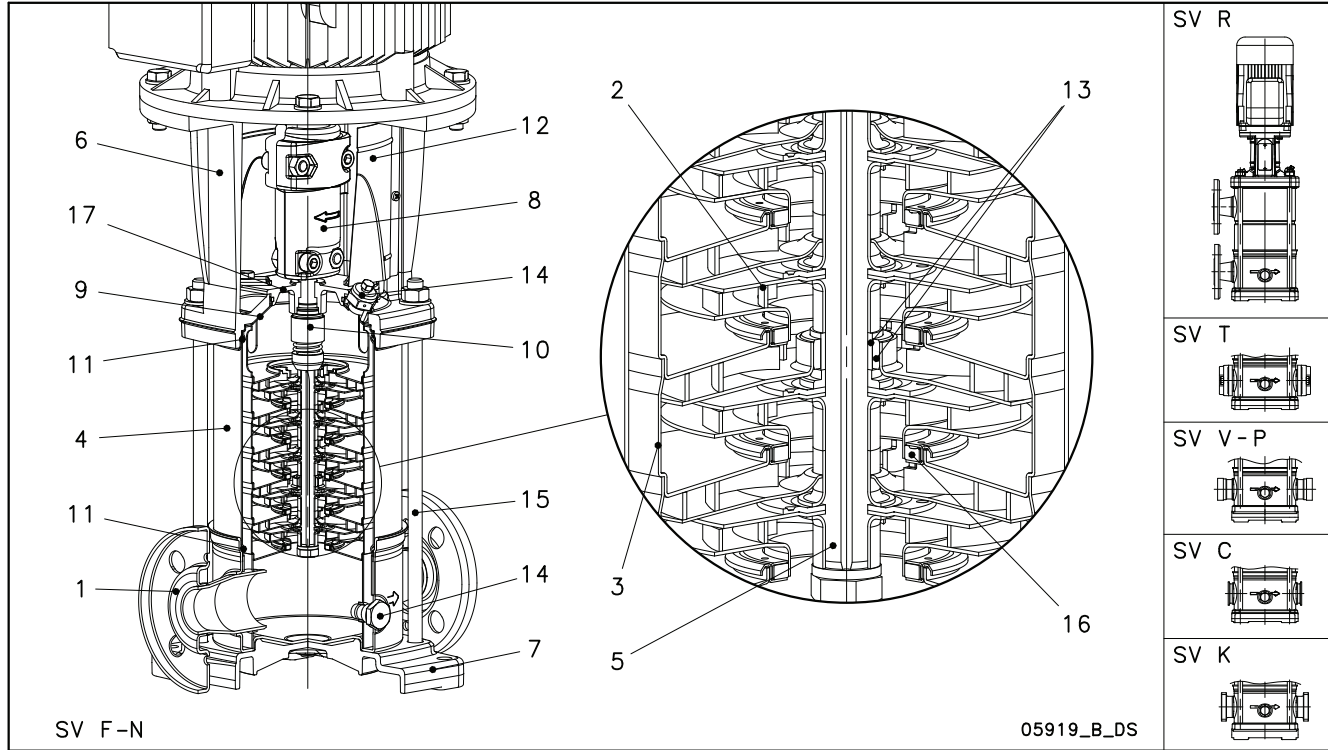

F, T, R VERSIONS

REF. N.	NAME	MATERIAL	REFERENCE STANDARDS	
			EUROPE	USA
1	Pump body	Stainless steel	EN 10088-1-X5CrNi18-10 (1.4301)	AISI 304
2	Impeller	Stainless steel	EN 10088-1-X5CrNi18-10 (1.4301)	AISI 304
3	Diffuser	Stainless steel	EN 10088-1-X5CrNi18-10 (1.4301)	AISI 304
4	Outer sleeve	Stainless steel	EN 10088-1-X5CrNi18-10 (1.4301)	AISI 304
5	Shaft	Stainless steel	EN 10088-1-X5CrNi18-10 (1.4301)	AISI 304
6	Adapter	Cast iron	EN 1561-GJL-250 (JL1040)	ASTM Class 35
7	Base	Aluminium	EN 1706-AC-AISI11Cu2 (Fe) (AC46100)	-
8	Coupling	Aluminium	EN 1706-AC-AISI11Cu2 (Fe) (AC46100)	-
9	Seal plate	Stainless steel	EN 10088-1-X5CrNi18-10 (1.4301)	AISI 304
10	Mechanical seal	Silicon carbide / Carbon / EPDM		
11	Elastomers	EPDM		
12	Coupling protection	Stainless steel	EN 10088-1-X5CrNi18-10 (1.4301)	AISI 304
13	Shaft sleeve and bushing	Tungsten carbide		
14	Fill / drain plugs	Stainless steel	EN 10088-1-X5CrNi18-10 (1.4301)	AISI 304
15	Tie rods	Galvanized steel	EN 10277-3-365MnPb14 (1.0765)	
16	Wear ring	Technopolymer PPS		
17	Seal gland	Stainless steel	EN 10213-4-GX5CrNi19-10 (1.4308)	AISI 304

N, V, C, K VERSIONS

10-22sv-ftr-en_b_tm

REF. N.	NAME	MATERIAL	REFERENCE STANDARDS	
			EUROPE	USA
1	Pump body	Stainless steel	EN 10088-1-X2CrNiMo17-12-2 (1.4404)	AISI 316L
2	Impeller	Stainless steel	EN 10088-1-X2CrNiMo17-12-2 (1.4404)	AISI 316L
3	Diffuser	Stainless steel	EN 10088-1-X2CrNiMo17-12-2 (1.4404)	AISI 316L
4	Outer sleeve	Stainless steel	EN 10088-1-X2CrNiMo17-12-2 (1.4404)	AISI 316L
5	Shaft	Stainless steel	EN 10088-1-X5CrNiMo17-12-2 (1.4401)	AISI 316
6	Adapter	Cast iron	EN 1561-GJL-250 (JL1040)	ASTM Class 35
7	Base	Aluminium	EN 1706-AC-AISI11Cu2 (Fe) (AC46100)	-
8	Coupling	Aluminium	EN 1706-AC-AISI11Cu2 (Fe) (AC46100)	-
9	Seal plate	Stainless steel	EN 10088-1-X2CrNiMo17-12-2 (1.4404)	AISI 316L
10	Mechanical seal	Silicon carbide / Carbon / EPDM		
11	Elastomers	EPDM		
12	Coupling protection	Stainless steel	EN 10088-1-X5CrNi18-10 (1.4301)	AISI 304
13	Shaft sleeve and bushing	Tungsten carbide		
14	Fill / drain plugs	Stainless steel	EN 10088-1-X5CrNiMo17-12-2 (1.4401)	AISI 316
15	Tie rods	Stainless steel	EN 10088-1-X17CrNi16-2 (1.4057)	AISI 431
16	Wear ring	Technopolymer PPS		
17	Seal gland	Stainless steel	EN 10213-4-GX5CrNiMo19-11-2 (1.4408)	AISI 316

10-22sv-nvck-en_a_tm

33, 46, 66, 92SV SERIES

ELECTRIC PUMP CROSS SECTION AND MAIN COMPONENTS

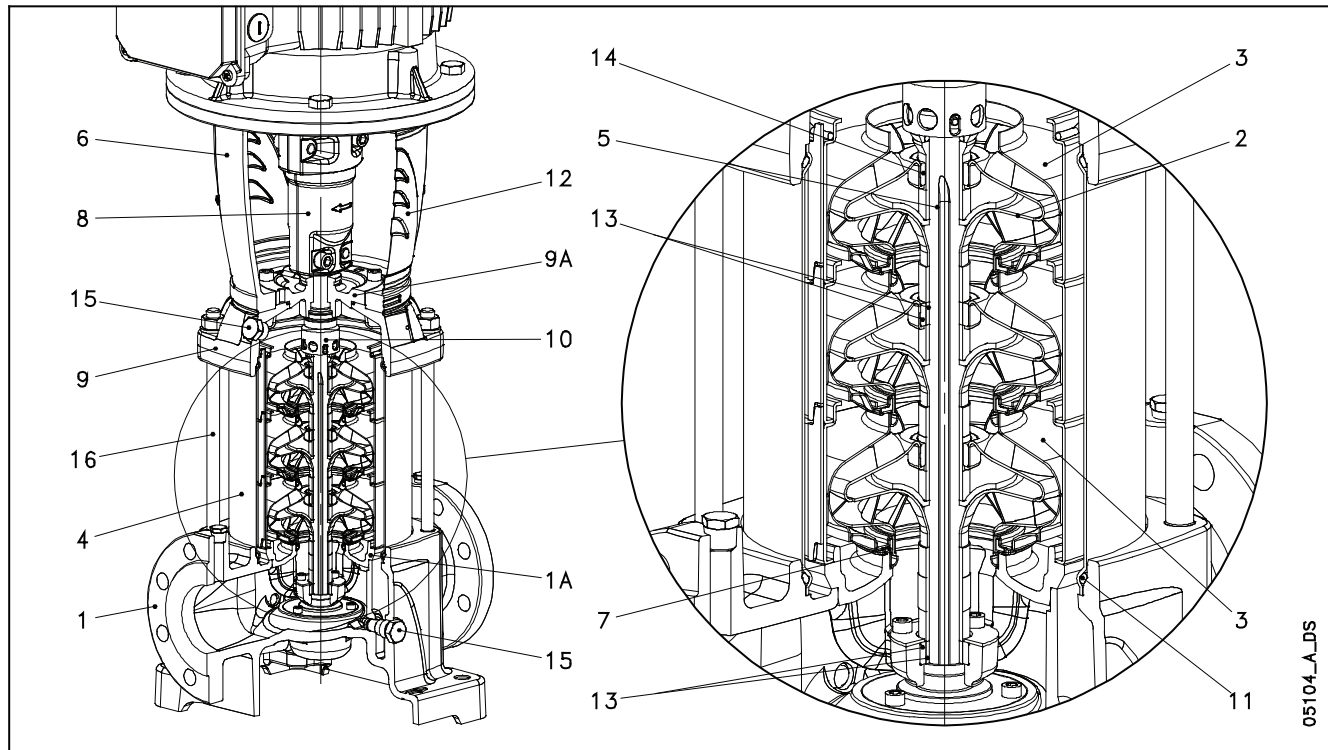

05104_A_DS

G VERSIONS

REF. N.	NAME	MATERIAL	REFERENCE STANDARDS	
			EUROPE	USA
1	Pump body	Cast iron	EN 1561-GJL-250 (JL1040)	ASTM Class 35
1A	Lower support	Cast iron	EN 1561-GJL-250 (JL1040)	ASTM Class 35
2	Impeller	Stainless steel	EN 10088-1-X2CrNiMo17-12-2 (1.4404)	AISI 316L
3	Diffuser	Stainless steel	EN 10088-1-X5CrNi18-10 (1.4301)	AISI 304
4	Outer sleeve	Stainless steel	EN 10088-1-X5CrNi18-10 (1.4301)	AISI 304
5	Shaft	Stainless steel	EN 10088-1 - X17CrNi16-2 (1.4057)	AISI 431
6	Adapter	Cast iron	EN 1561-GJL-200 (JL1030)	ASTM Class 25
7	Wear ring	Technopolymer PPS		
8	Coupling	Cast iron	EN 1561-GJL-200 (JL1030)	ASTM Class 25
9	Upper head	Cast iron	EN 1561-GJL-250 (JL1040)	ASTM Class 35
9A	Seal housing	Cast iron	EN 1561-GJL-250 (JL1040)	ASTM Class 35
10	Mechanical seal	Silicon carbide / Carbon / EPDM		
11	Elastomers	EPDM		
12	Coupling protection	Stainless steel	EN 10088-1-X5CrNi18-10 (1.4301)	AISI 304
13	Shaft sleeve and bushing	Tungsten carbide		
14	Bushing for diffuser	Carbon		
15	Fill / Drain plugs	Stainless steel	EN 10088-1-X5CrNiMo17-12-2 (1.4401)	AISI 316
16	Tie rods	Galvanized steel	EN 10277-3-36SMnPb14 (1.0765)	-

33-92sv-g-en_a_tm

N VERSIONS

REF. N.	NAME	MATERIAL	REFERENCE STANDARDS	
			EUROPE	USA
1	Pump body	Stainless steel	EN 10213-4-GX5CrNiMo19-11-2 (1.4408)	ASTM CF8M (AISI 316 cast)
1A	Lower support	Stainless steel	EN 10213-4-GX5CrNiMo19-11-2 (1.4408)	ASTM CF8M (AISI 316 cast)
2	Impeller	Stainless steel	EN 10088-1-X2CrNiMo17-12-2 (1.4404)	AISI 316L
3	Diffuser	Stainless steel	EN 10088-1-X2CrNiMo17-12-2 (1.4404)	AISI 316L
4	Outer sleeve	Stainless steel	EN 10088-1-X2CrNiMo17-12-2 (1.4404)	AISI 316L
5	Shaft	Duplex stainless steel	EN 10088-1-X2CrNiMoN22-5-3 (1.4462)	UNS S 31803
6	Adapter	Cast iron	EN 1561-GJL-200 (JL1030)	ASTM Class 25
7	Wear ring	Technopolymer PPS		
8	Coupling	Cast iron	EN 1561-GJL-200 (JL1030)	ASTM Class 25
9	Upper head	Stainless steel	EN 10213-4-GX5CrNiMo19-11-2 (1.4408)	ASTM CF8M (AISI 316 cast)
9A	Seal housing	Stainless steel	EN 10213-4-GX5CrNiMo19-11-2 (1.4408)	ASTM CF8M (AISI 316 cast)
10	Mechanical seal	Silicon carbide / Carbon / EPDM		
11	Elastomers	EPDM		
12	Coupling protection	Stainless steel	EN 10088-1-X5CrNi18-10 (1.4301)	AISI 304
13	Shaft sleeve and bushing	Tungsten carbide		
14	Bushing for diffuser	Carbon		
15	Fill / drain / air plugs	Stainless steel	EN 10088-1-X5CrNiMo17-12-2 (1.4401)	AISI 316
16	Tie rods	Stainless steel	EN 10088-1-X17CrNi16-2 (1.4057)	AISI 431

33-92sv-n-en_a_tm

125SV SERIES ELECTRIC PUMP CROSS SECTION AND MAIN COMPONENTS

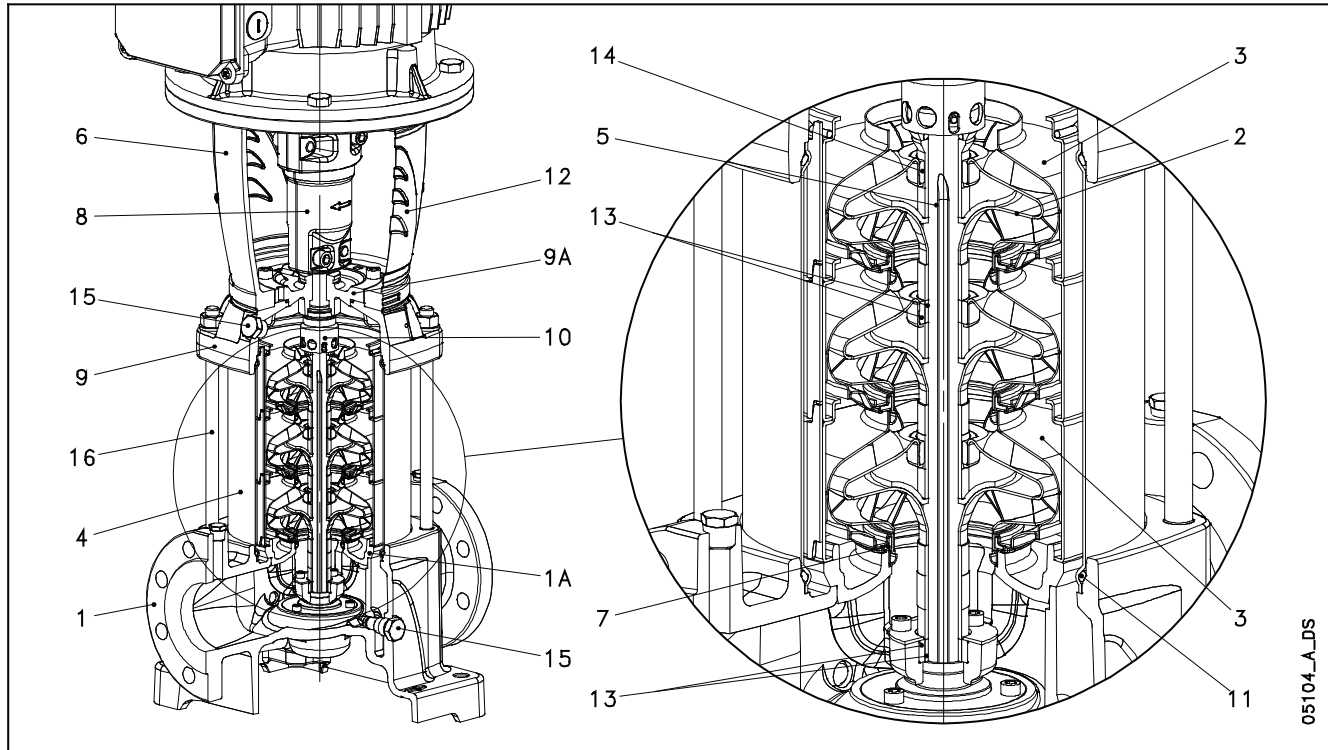

G VERSIONS

REF. N.	NAME	MATERIAL	REFERENCE STANDARDS	
			EUROPE	USA
1	Pump body	Cast iron	EN 1561-GJL-250 (JL1040)	ASTM Class 35
1A	Lower support	Stainless steel	EN 10213-GX5CrNi19-10 (1.4308)	AISI 304
2-3	Impeller, Diffuser	Stainless steel	EN 10213-GX5CrNi19-10 (1.4308)	AISI 304
4	Outer sleeve	Stainless steel	EN 10088-1-X5CrNi18-10 (1.4301)	AISI 304
5	Shaft	Stainless steel	EN 10088-1 - X17CrNi16-2 (1.4057)	AISI 431
6	Adapter (up to 45kW)	Cast iron	EN 1561-GJL-200 (JL1030)	ASTM Class 25
	Adapter (for higher powers)	Cast iron	EN 1563-GJS-500-7 (JS1050)	ASTM A 536 80-55-06
7	Wear ring	Technopolymer PPS		
8	Coupling (up to 45kW)	Cast iron	EN 1561-GJL-200 (JL1030)	ASTM Class 25
	Coupling (for higher powers)	Cast iron	EN 1563-GJS-500-7 (JS1050)	ASTM A 536 80-55-06
9-9A	Upper head, Seal housing	Cast iron	EN 1561-GJL-250 (JL1040)	ASTM Class 35
10	Mechanical seal	Silicon carbide / Carbon / EPDM		
11	Elastomers	EPDM		
12	Coupling protection	Stainless steel	EN 10088-1-X5CrNi18-10 (1.4301)	AISI 304
13	Shaft sleeve and bushing	Tungsten carbide		
14	Bushing for diffuser	Carbon		
15	Fill / drain / air plugs	Stainless steel	EN 10088-1-X5CrNiMo17-12-2 (1.4401)	AISI 316
16	Tie rods	Galvanized steel	EN 10277-3-365MnPb14 (1.0765)	-
17	Adapter ring	Stainless steel	EN 10213-GX5CrNi19-10 (1.4308)	AISI 304

N VERSIONS

125sv-g-en_a_tm

REF. N.	NAME	MATERIAL	REFERENCE STANDARDS	
			EUROPE	USA
1	Pump body	Stainless steel	EN 10213-4-GX5CrNiMo19-11-2 (1.4408)	ASTM CF8M (AISI 316)
1A	Lower support	Stainless steel	EN 10213-4-GX5CrNiMo19-11-2 (1.4408)	ASTM CF8M (AISI 316)
2-3	Impeller, Diffuser	Stainless steel	EN 10213-4-GX5CrNiMo19-11-2 (1.4408)	ASTM CF8M (AISI 316)
4	Outer sleeve	Stainless steel	EN 10088-1-X2CrNiMo17-12-2 (1.4404)	AISI 316L
5	Shaft	Duplex stainless steel	EN 10088-1-X2CrNiMoN22-5-3 (1.4462)	UNS S 31803
6	Adapter	Cast iron	EN 1561-GJL-200 (JL1030)	ASTM Class 25
	Adapter	Cast iron	EN 1563-GJS-500-7 (JS1050)	
7	Wear ring	Technopolymer PPS		
8	Coupling	Cast iron	EN 1561-GJL-200 (JL1030)	ASTM Class 25
	Coupling	Cast iron	EN 1563-GJS-500-7 (JS1050)	
9-9A	Upper head, Seal housing	Stainless steel	EN 10213-4-GX5CrNiMo19-11-2 (1.4408)	ASTM CF8M (AISI 316)
10	Mechanical seal	Silicon carbide / Carbon / EPDM		
11	Elastomers	EPDM		
12	Coupling protection	Stainless steel	EN 10088-1-X5CrNi18-10 (1.4301)	AISI 304
13	Shaft sleeve and bushing	Tungsten carbide		
14	Bushing for diffuser	Carbon		
15	Fill / drain / air plugs	Stainless steel	EN 10088-1-X5CrNiMo17-12-2 (1.4401)	AISI 316
16	Tie rods	Stainless steel	EN 10088-1-X17CrNi16-2 (1.4057)	AISI 431
17	Adapter ring	Stainless steel	EN 10213-4-GX5CrNiMo19-11-2 (1.4408)	ASTM CF8M (AISI 316)

125sv-n-en_a_tm

**e-SV SERIES
MECHANICAL SEALS, ACCORDING TO EN 12756**

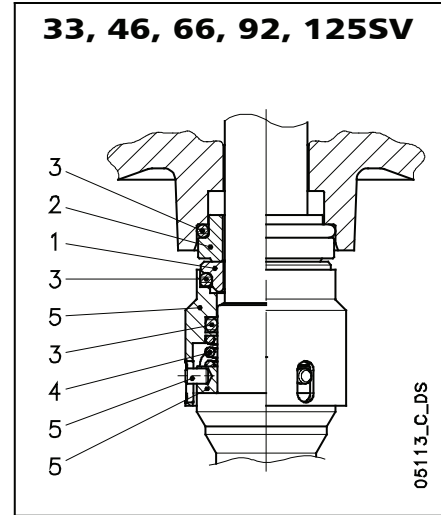
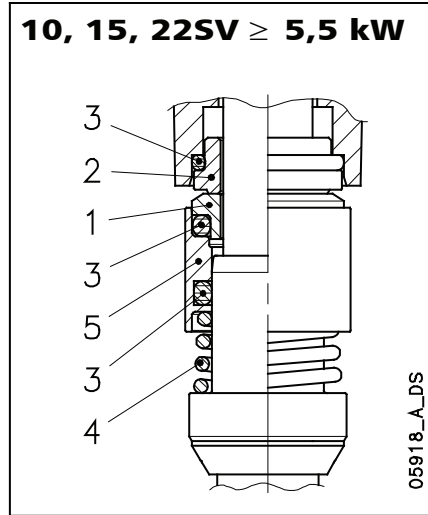
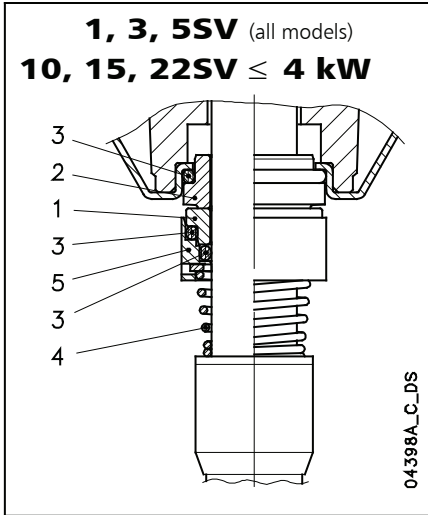

LIST OF MATERIALS

POSITION 1 - 2	POSITION 3	POSITION 4 - 5
Q ₁ : Silicon Carbide	E : EPDM	G : AISI 316
B : Resin impregnated carbon	V : FKM (FPM)	
C : Special resin impregnated carbon	T : PTFE	

TYPE OF SEAL

sv_ten-mec-en_b_tm

TYPE	POSITION					TEMPERATURE (°C)
	1 ROTATING PART	2 STATIONARY PART	3 ELASTOMERS	4 SPRINGS	5 OTHER COMPONENTS	
STANDARD MECHANICAL SEAL						
Q ₁ B E G G	Q ₁	B	E	G	G	-30 +120
OTHER TYPES OF AVAILABLE MECHANICAL SEAL						
Q ₁ Q ₁ E G G	Q ₁	Q ₁	E	G	G	-30 +120
Q ₁ B V G G	Q ₁	B	V	G	G	-10 +120
Q ₁ Q ₁ V G G	Q ₁	Q ₁	V	G	G	-10 +120
*Q ₁ C T G G	Q ₁	C	T	G	G	0 +120
*Q ₁ Q ₁ T G G	Q ₁	Q ₁	T	G	G	0 +120

* Versions with anti-rotation lock pin of the fixed part.

sv_tipi-ten-mec-en_b_tc

PRESSURE/TEMPERATURE APPLICATION LIMITS FOR COMPLETE PUMP

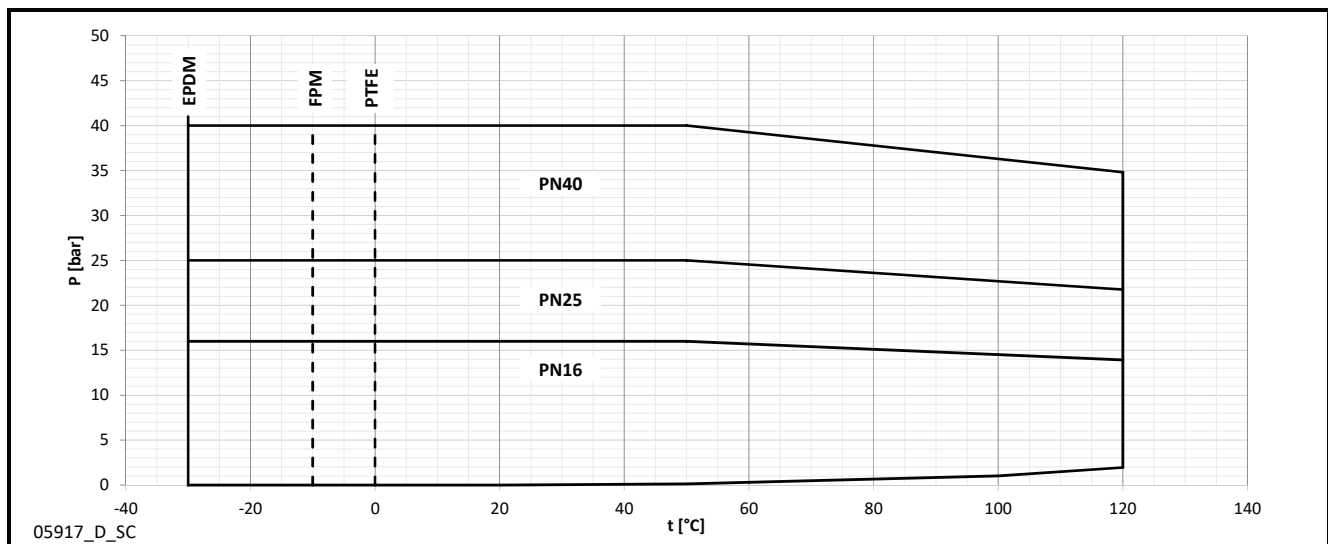

COMPATIBILITY CHART FOR MATERIALS IN CONTACT WITH MOST COMMONLY USED LIQUIDS

LIQUID	CONCENTRATION (%)	TEMPERAT. MIN/MAX (°C)	VERSIONE			ELASTOM.
			PLASTIC	AISI 304	AISI 316	
Acetone	10	-10 +90		•	•	E
Ammonia	10	-10 +40	•	•	•	E
Benzene	10	-10 +50		•	•	V
Citric acid	10	-10 +70	•	•	•	E
Cutting oil	100	-5 +110		•	•	V
Deionized, demineralized water	100	10 +110	•	•	•	V
Denatured alcohol	100	-5 +70	•	•	•	E
Diathermic oil	100	-5 +110		•	•	V
Diesel	100	-10 +80	•	•	•	V
Ethyl alcohol	100	-30 +50	•	•	•	E
Ethylene glycol	50	-30 +120		•	•	E
Glycerine	100	20 +90	•	•	•	E
Hydraulic oil	100	-5 +110		•	•	V
Hydrochloric acid	2	-10 +25	•		•	V
Methyl alcohol	100	-30 +50	•	•	•	E
Mineral oil	100	-5 +110		•	•	V
Mixture of water, detergents	20	10 +100	•	•	•	E
Phosphates-polyphosphates	10	-5 +90	•	•	•	V
Propyl alcohol (Propanol)	100	-5 +80		•	•	E
Propylene Glycol	50	-30 +120		•	•	E
Sea water (max 1000 ppm Chlorides)	100	-10 +30			•	V
Sodium bicarbonate	saturated		•	•	•	E
Sodium hydroxide	20	10 +70	•	•	•	E
Sodium hypochlorite	1	-10 +25	•		•	V
Sulfuric acid	2	-10 +25	•	•	•	V
Toluene	10	-10 +50		•	•	V
Uric acid	80	-10 +80		•	•	E
Vegetable oil	100	10 +110		•	•	V
Water and oil emulsion	all	-5 +90		•	•	V
Waterfall	100	10 +120	•	•	•	E

tab-comp-en_a_tm

The above table indicates the compatibility of materials depending on the pumped liquid. Check the specific weight of the liquid or the viscosity as this could affect the power input of the motor and hydraulic performance. For further details, please contact the sales network.

HIGH PRESSURE (50/60 Hz)

e-SV SERIES - HIGH PRESSURE, DUAL PUMP SYSTEM 50/60 Hz

Background and context

In the water treatment industry (Ultra or Nano filtration, reverse osmosis) in the washing and cleaning industry (High pressure washdown systems) or with boiler-feed application, high pressure is mandatory to ensure consistency in the performance of the systems. Therefore Lowara has developed e-SV High Pressure: a wide range of pumps and pump systems able to deliver robust and durable performances up to 40 bar.

Benefits of e-SV HIGH PRESSURE

Versatile range: e-SV High Pressure is available in two different configurations: single pump solution or tandem pump solution (two pumps in series). If the inlet pressure value is already high, Lowara delivers a single pump able to withstand the high inlet pressure and deliver up to 40 bar pressure at the outlet. With applications where the high pressure has to be delivered starting from atmospheric pressure in the inlet, Lowara delivers the tandem solution able to deliver up to 40 bar pressure at the outlet of the system.

Long lasting performances: e-SV High Pressure benefits of a particular design of the sleeve to withstand the internal pressure without any limitation in the inlet pressure but with maximum 40 bar measured at the outlet. The specific balanced mechanical seal and the balanced design of the impeller and the hard material intermediate bush bearing allows e-SV withstanding up to 40 bar without stressing the motor and the pump components, with a direct consequence on the reduction of the life cycle cost.

Easy installation and maintenance: e-SV High Pressure in tandem system is composed of two identical standard e-SV High Pressure pumps making replacement easy and cost-effective. e-SV High Pressure in tandem has to be ordered as two single e-SV High Pressure pumps together with the specific accessories for the installation (see specific accessories section).

Code identification

e-SV High Pressure design is identified with a "**P**" in the product codification of the whole e-SV range.

Example: 3SV13**P**015T

P = High Pressure version.



Special features / product benefits

- **Double sleeve design** to withstand high pressure up to 40 bar.
- **Balanced standard mechanical seal** (EN12756) on all models. **Easy to replace, without removing the motor** from 5,5 kW.
- **Hard material intermediate bush bearing** (Tungsten Carbide) to improve lifetime and capacity of working in extreme conditions, available on all sizes.
- **Balanced impeller design** to reduce axial thrust for longer standard motor bearing life.
- Wide range of size to cover all requested duty points: from 1SV to 125SV.
- **IE2** efficiency level (three-phase 0,12-0,749 kW), **IE3** efficiency level (three-phase 0,75 to 1000 kW) **standard motors**, 2-poles with blocked bearing **to support maximum thrust without limiting inlet pressure.**

Special configurations

e-SV High Pressure offers a wide range of configurations:

- Materials used: see the Materials section.
- Options for mechanical seals and gaskets: see the mechanical seals and gaskets section.
- Options for motors and configuration: see the motors section.
- HYDROVAR™ system included

e-SV SERIES - HIGH PRESSURE 50/60 Hz

Technical characteristics - Design

1: Double sleeve design for optimized resistance to pressure up to 40 bar.

2: Balanced mechanical seal to withstand high pressure.

Operating characteristics for single pump

For the hydraulic performances of the single pump, please refer to the standard catalogue of e-SV.

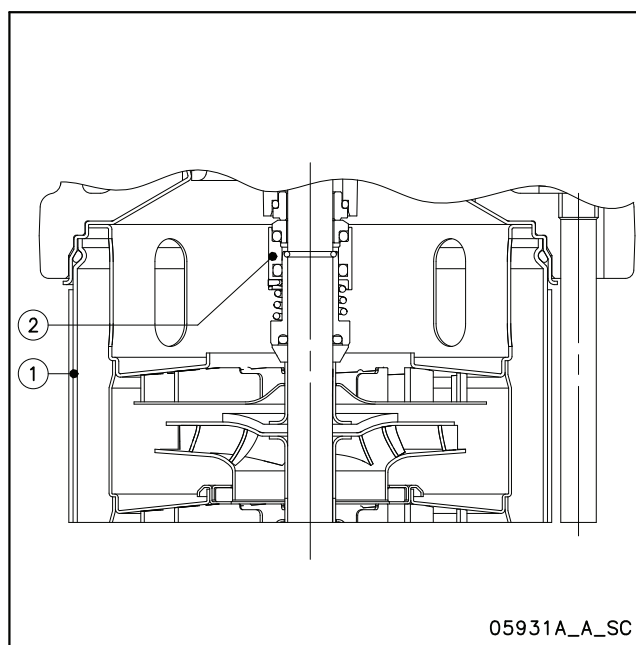

TECHNICAL CHARACTERISTICS

P VERSIONS - 50 Hz	1SV	3SV	5SV	10SV	15SV	22SV	33SV	46SV	66SV	92SV	125SV
Max efficiency flow (m ³ /h)	1.7	3	5.5	10.5	16.5	20.5	31	43	72	90	120
Flow range (m ³ /h)	0,7÷2,4	1,2÷4,4	2,4÷8,5	5÷14	8÷24	11÷29	15÷40	22÷60	30÷85	45÷120	60÷160
Maximum head (m)	400	380	400	385	380	400	380	400	380	400	370
PN (bar)	40										
Motor power (kW)	0,37÷2,2	0,37÷3	0,37÷5,5	0,75÷11	1,1÷15	1,1÷18,5	2,2÷30	3÷45	4÷45	5,5÷55	7,5÷55
Max η (%) of pump	50	60	70	71	72	73	77	79	78	80	78
Standard temperature of pumped liquid (°C)	-30 +120										
Material execution	No variation according to e-SV N version (AISI 316)										
Mechanical seal configuration	Balanced mechanical seal. Standard materials: Silicon Carbide / Carbon / EPDM										
Flange configuration	Victaulic® coupling (1, 3, 5, 10, 15, 22SV versions) Round flange (33, 46, 66, 92, 125SV versions)										

svp-50-en_c_tg

P VERSIONS - 60 Hz	1SV	3SV	5SV	10SV	15SV	22SV	33SV	46SV	66SV	92SV	125SV
Max efficiency flow (m ³ /h)	2	3.6	7	12.4	21.8	24.5	40	50	87	108	144
Flow range (m ³ /h)	0,8÷2,8	1,4÷5,2	3÷10	6÷17	10÷29	13÷34	18÷48	27÷72	36÷102	54÷144	60÷160
Maximum head (m)	400	400	400	385	390	400	380	390	400	330	360
PN (bar)	40										
Motor power (kW)	0,37÷3	0,37÷4	0,55÷5,5	0,75÷11	1,5÷18,5	2,2÷18,5	3÷37	5,5÷45	7,5÷45	11÷45	15÷55
Max η (%) of pump	50	60	70	71	72	73	77	79	78	80	78
Standard temperature of pumped liquid (°C)	-30 +120										
Material execution	No variation according to e-SV N version (AISI 316)										
Mechanical seal configuration	Balanced mechanical seal. Standard materials: Silicon Carbide / Carbon / EPDM										
Flange configuration	Victaulic® coupling (1, 3, 5, 10, 15, 22SV versions) Round flange (33, 46, 66, 92, 125SV versions)										

svp-60-en_c_tg

**e-SV SERIES - HIGH PRESSURE
BALANCED MECHANICAL SEALS, ACCORDING TO EN 12756**

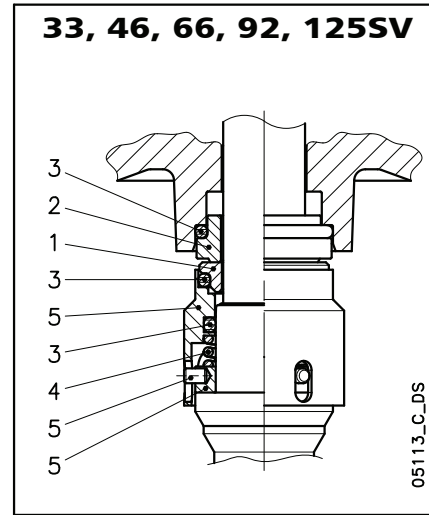
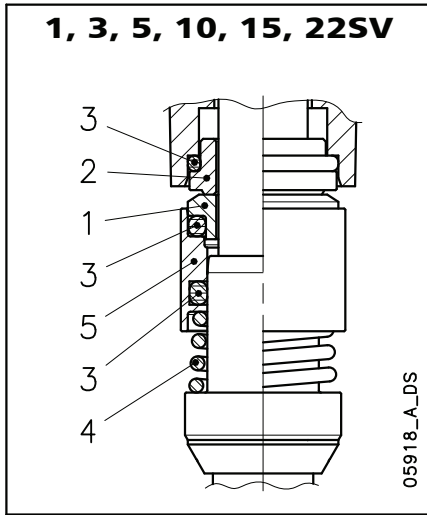

LIST OF MATERIALS

POSITION 1 - 2	POSITION 3	POSITION 4 - 5
Q ₁ : Silicon Carbide	E : EPDM	G : AISI 316
B : Resin impregnated carbon	V : FPM	

1-125sv-p_ten-mec-en_a_tm

TYPE OF SEAL

TYPE	POSITION					TEMPERATURE (°C)
	1 ROTATING PART	2 STATIONARY PART	3 ELASTOMERS	4 SPRINGS	5 OTHER COMPONENTS	
STANDARD MECHANICAL SEAL						
Q ₁ B E G G	Q ₁	B	E	G	G	-30 +120
OTHER TYPES OF AVAILABLE MECHANICAL SEAL						
Q ₁ Q ₁ E G G	Q ₁	Q ₁	E	G	G	-30 +120
Q ₁ B V G G	Q ₁	B	V	G	G	-10 +120
Q ₁ Q ₁ V G G	Q ₁	Q ₁	V	G	G	-10 +120

1-125sv-p_tipi-ten-mec-en_a_tc

PRESSURE/TEMPERATURE APPLICATION LIMITS FOR COMPLETE PUMP

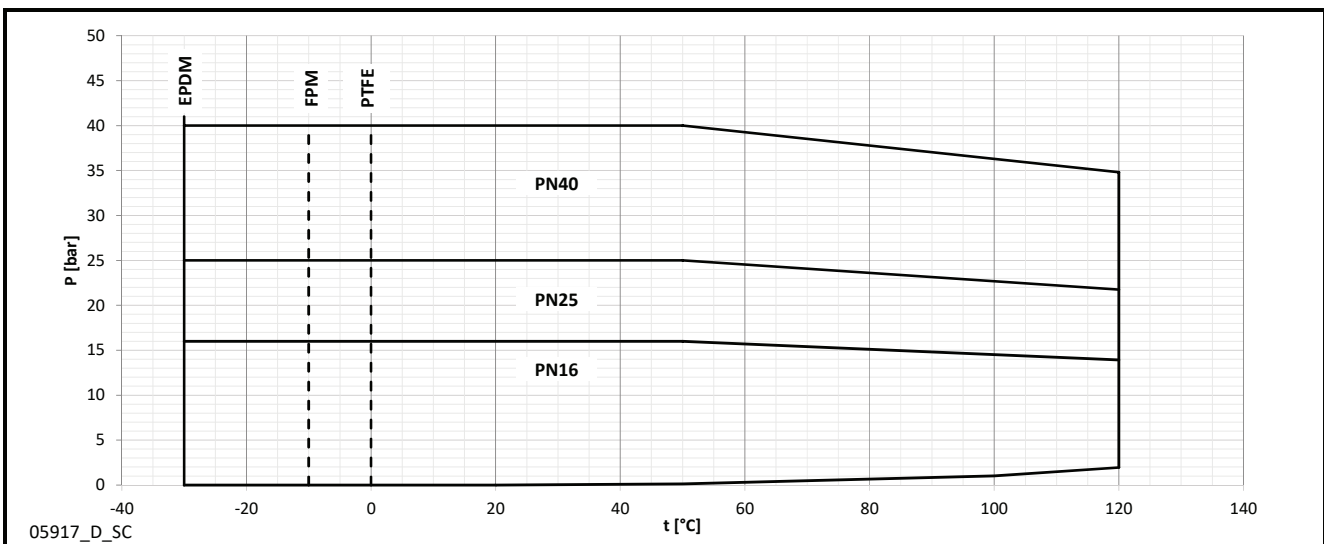

05917_D_SC

**SV..P SERIES - HIGH PRESSURE
HYDRAULIC PERFORMANCE RANGE AT 50 Hz**

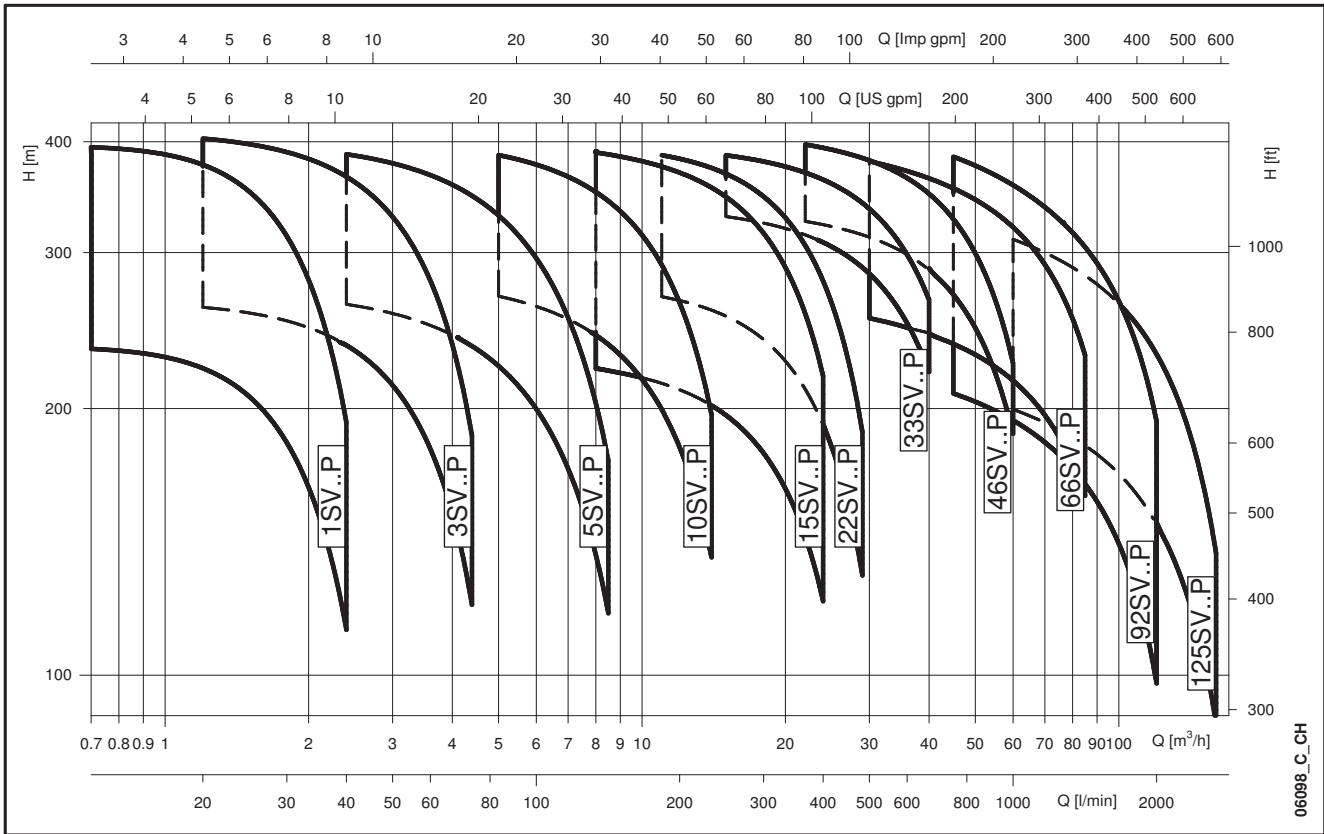

**SV..P SERIES - HIGH PRESSURE
HYDRAULIC PERFORMANCE RANGE AT 60 Hz**

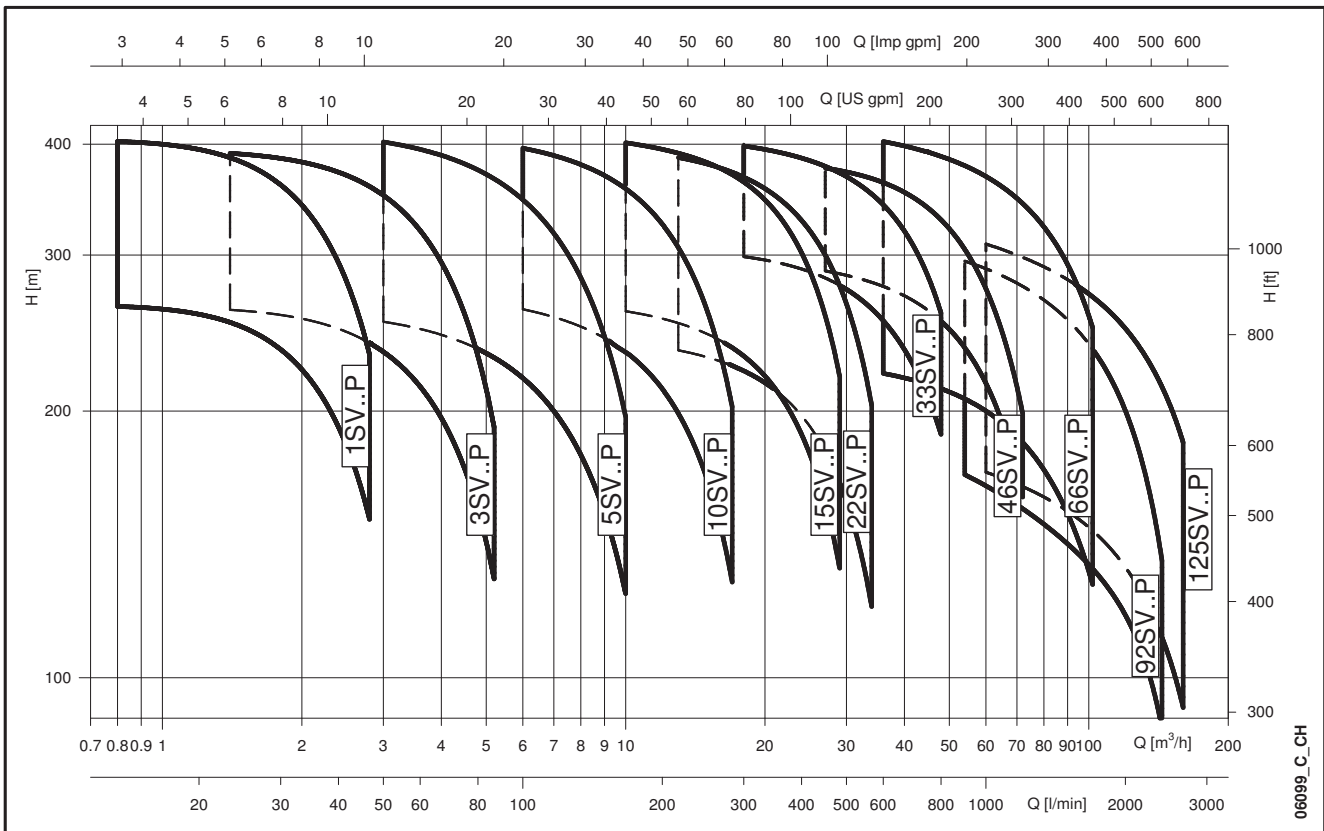

1SV..P SERIES - HIGH PRESSURE DIMENSIONS AND WEIGHTS AT 50 Hz, 2-POLE

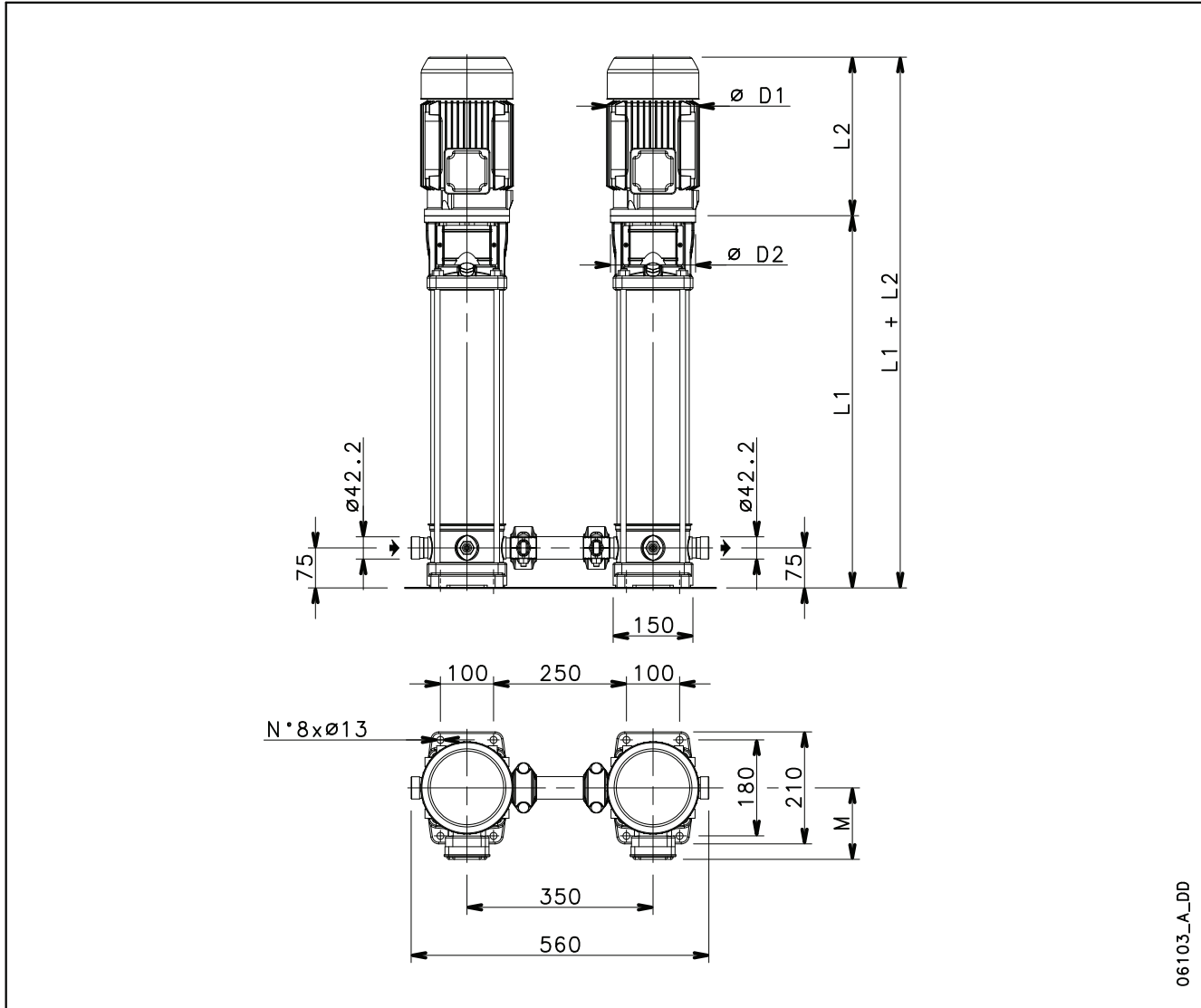

PUMP TYPE	MOTOR		DIMENSIONS (mm)					WEIGHT (Kg)	
	kW	Size	L1	L2	M	D1	D2	PUMP	ELECTRIC PUMP
1SV19P../D	1,1	80	628	263	129	155	120	17,5	29,1
1SV22P../D	1,1	80	688	263	129	155	120	19	30,6
1SV25P../D	1,5	90	758	263	129	155	140	21,2	34,2
1SV27P../D	1,5	90	798	263	129	155	140	22,2	35,2
1SV30P../D	1,5	90	858	263	129	155	140	23,6	36,6
1SV32P..	2,2	90	898	298	134	174	140	24,6	42,8

Dimensions and weights are related to one electric pump.

1sv-p-2p50-en_d_td

**1SV..P SERIES - HIGH PRESSURE
OPERATING CHARACTERISTICS AT 50 Hz, 2-POLE**

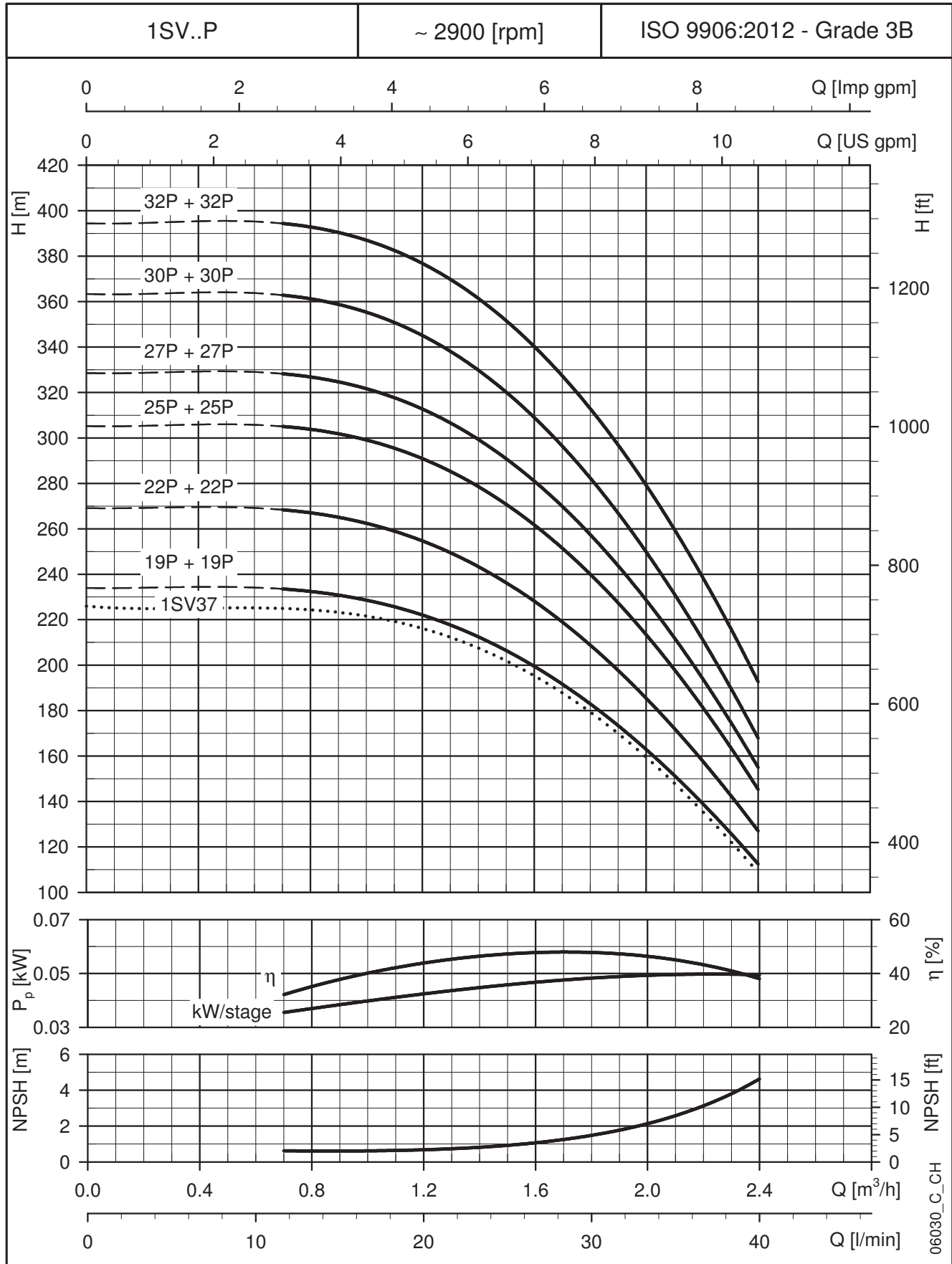

These performances are valid for liquids with density $\rho = 1.0 \text{ Kg/dm}^3$ and kinematic viscosity $\nu = 1 \text{ mm}^2/\text{sec}$.

3SV..P SERIES - HIGH PRESSURE DIMENSIONS AND WEIGHTS AT 50 Hz, 2-POLE

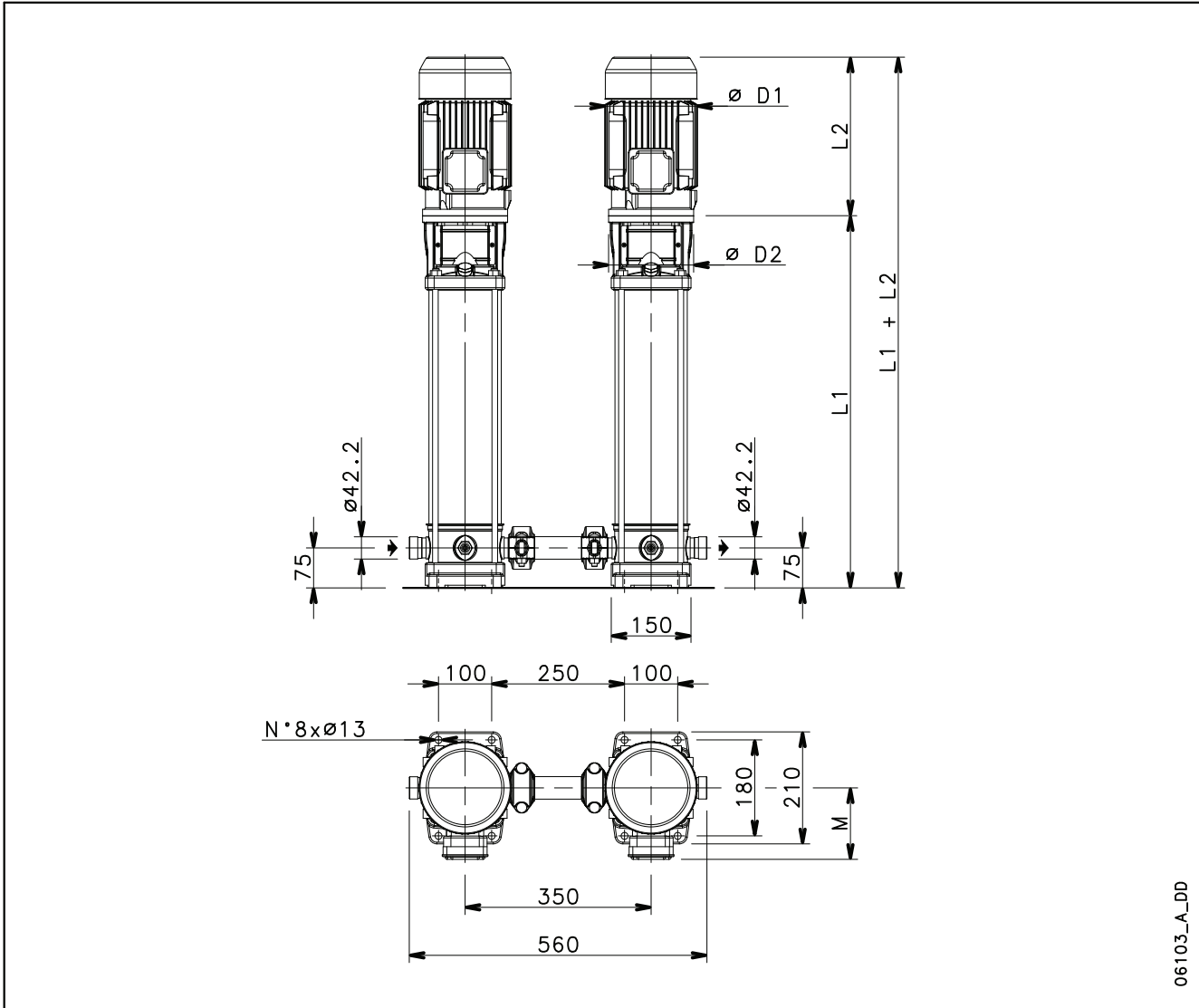

06103_A_DD

PUMP TYPE	MOTOR		DIMENSIONS (mm)					WEIGHT (Kg)	
	kW	Size	L1	L2	M	D1	D2	PUMP	ELECTRIC PUMP
3SV16P../D	1,5	90	578	263	129	155	140	17	30
3SV19P..	2,2	90	638	298	134	174	140	18,4	36,6
3SV21P..	2,2	90	678	298	134	174	140	19,4	37,6
3SV23P..	2,2	90	718	298	134	174	140	20,3	38,5
3SV25P..	2,2	90	758	298	134	174	140	21,4	39,6
3SV27P..	3	100	808	298	134	174	160	23,4	38,5

Dimensions and weights are related to one electric pump.

3sv-o-2b50-en d td

**3SV..P SERIES - HIGH PRESSURE
OPERATING CHARACTERISTICS AT 50 Hz, 2-POLE**

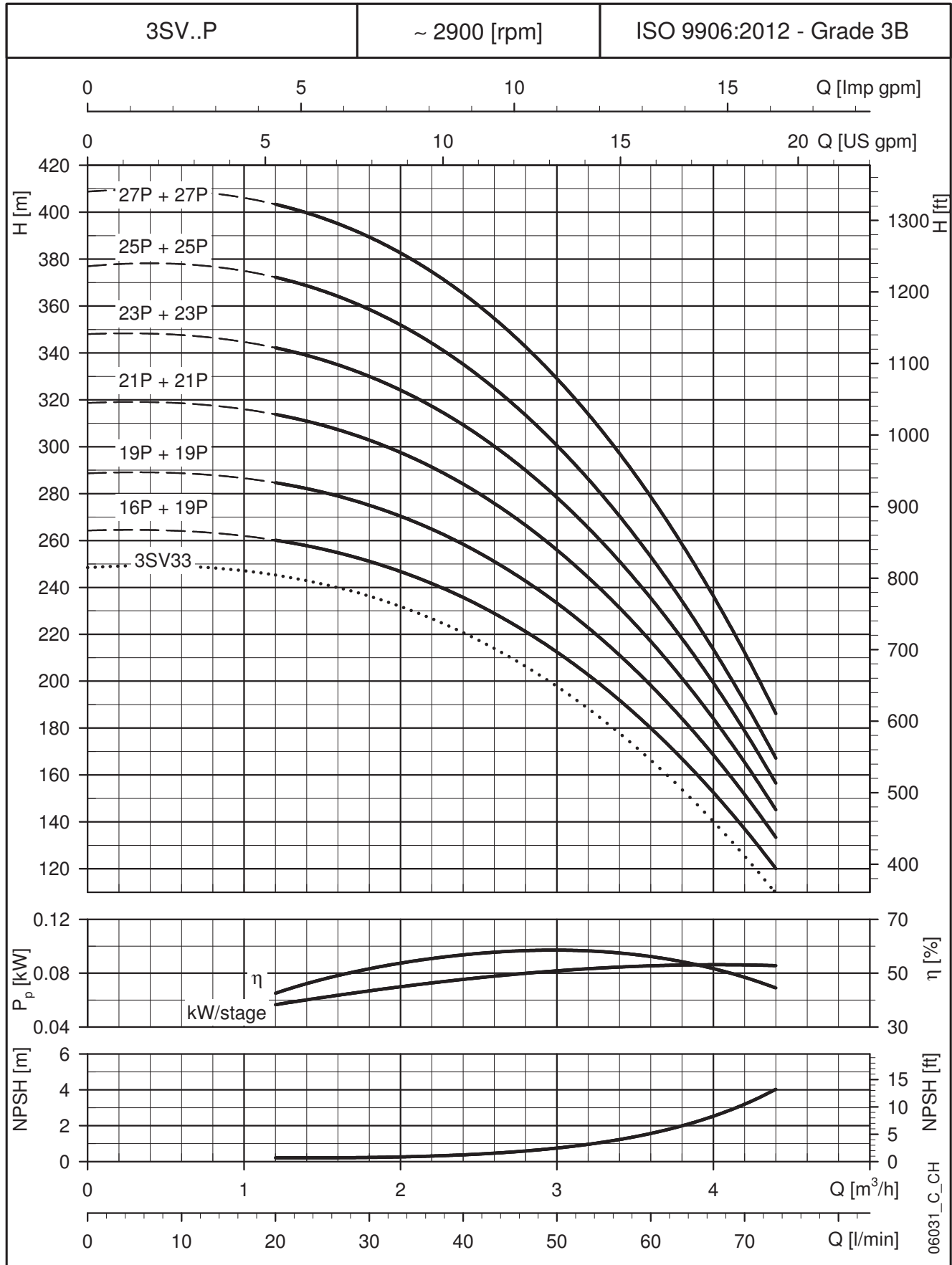

These performances are valid for liquids with density $\rho = 1.0 \text{ Kg/dm}^3$ and kinematic viscosity $\nu = 1 \text{ mm}^2/\text{sec}$.

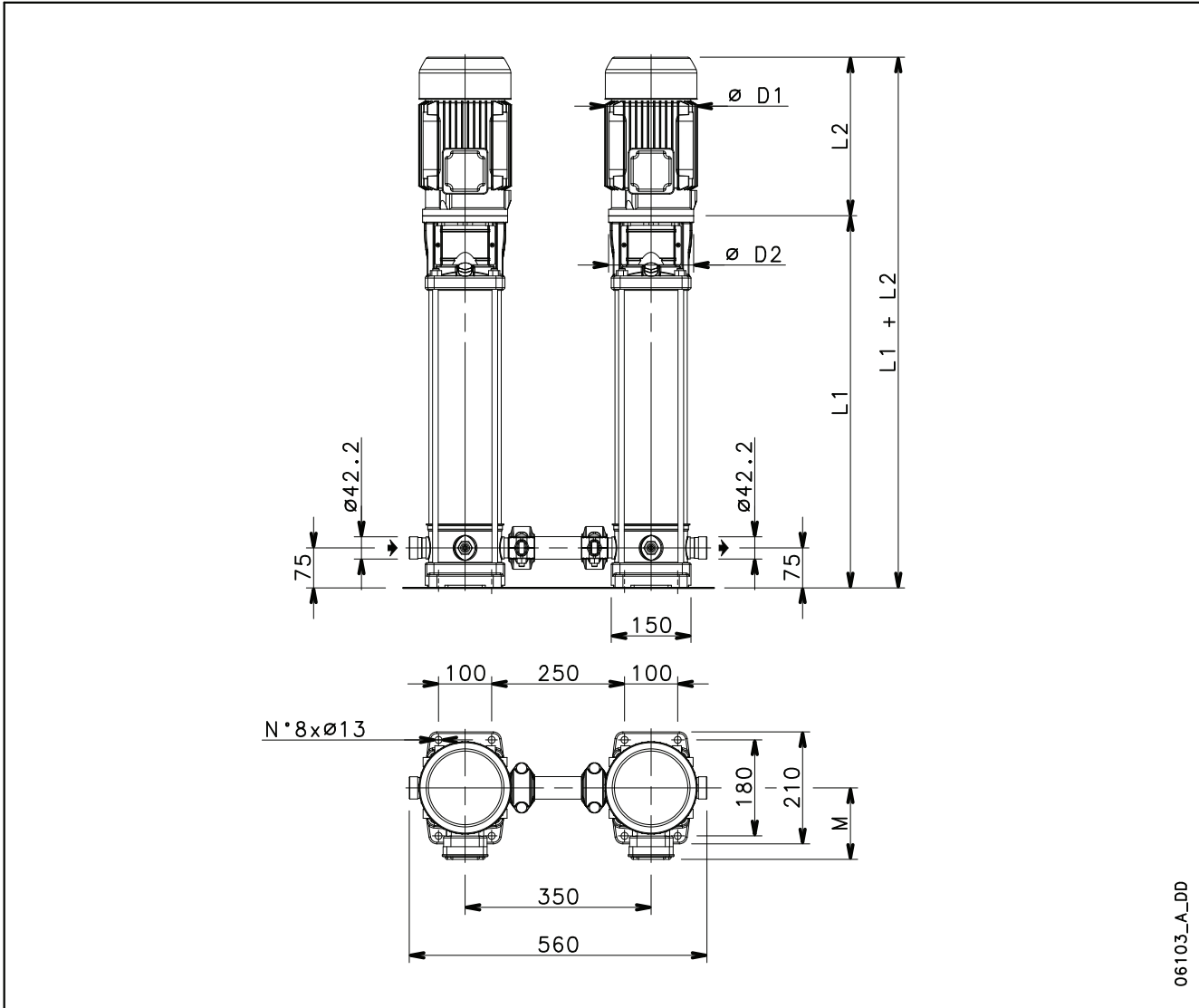
**5SV..P SERIES - HIGH PRESSURE
DIMENSIONS AND WEIGHTS AT 50 Hz, 2-POLE**

PUMP TYPE	MOTOR		DIMENSIONS (mm)					WEIGHT (Kg)	
	kW	Size	L1	L2	M	D1	D2	PUMP	ELECTRIC PUMP
5SV18P..	3	100	723	298	134	174	160	20,4	41,4
5SV21P..	3	100	798	298	134	174	160	22,1	43,1
5SV23P..	4	112	848	319	154	197	160	23,3	49,7
5SV25P..	4	112	898	319	154	197	160	24,4	50,8
5SV28P..	4	112	973	319	154	197	160	26,4	52,8

Dimensions and weights are related to one electric pump.

5sv-p-2p50-en_d_td

**5SV..P SERIES - HIGH PRESSURE
OPERATING CHARACTERISTICS AT 50 Hz, 2-POLE**

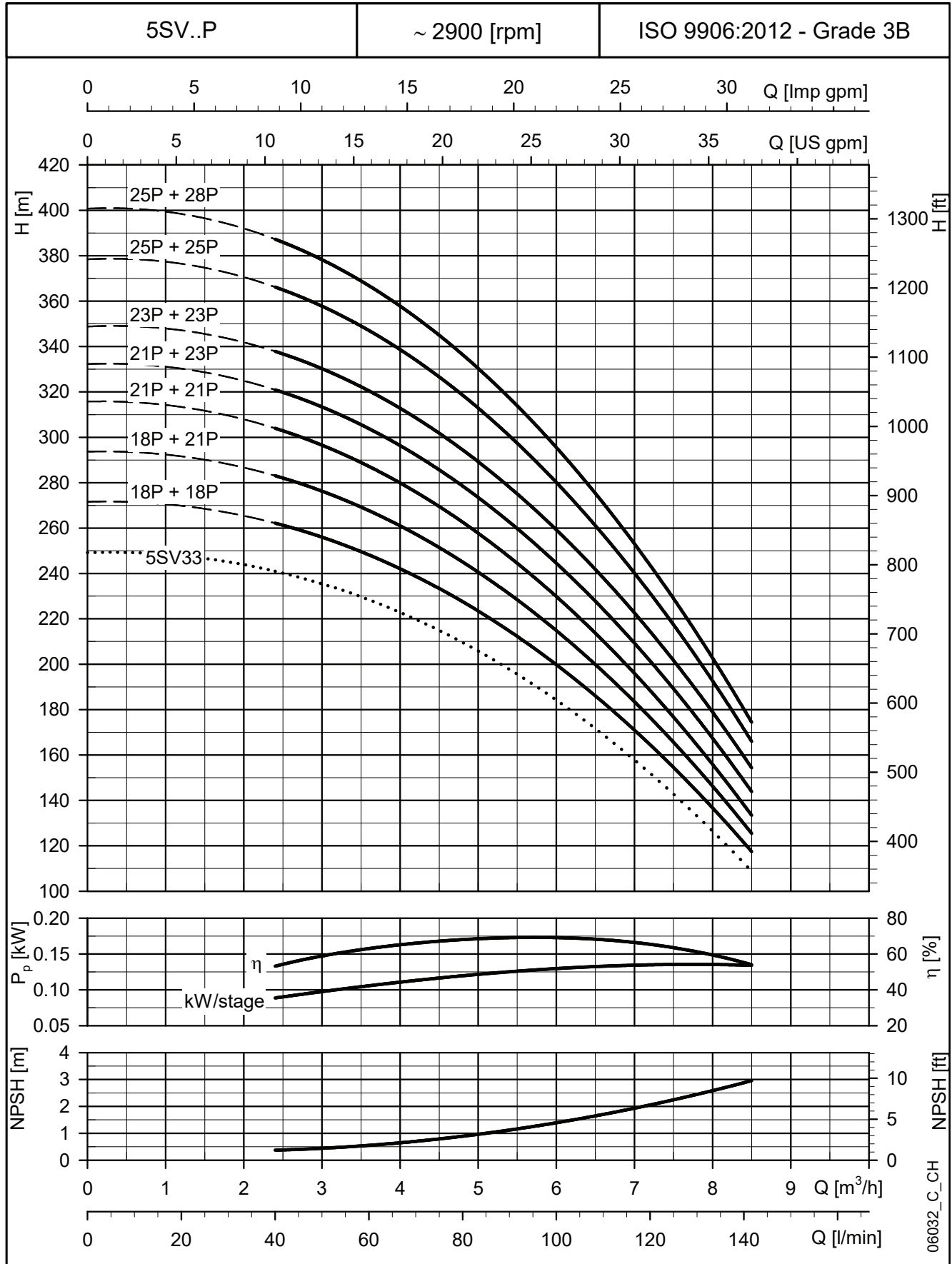

These performances are valid for liquids with density $\rho = 1.0 \text{ Kg/dm}^3$ and kinematic viscosity $\nu = 1 \text{ mm}^2/\text{sec}$.

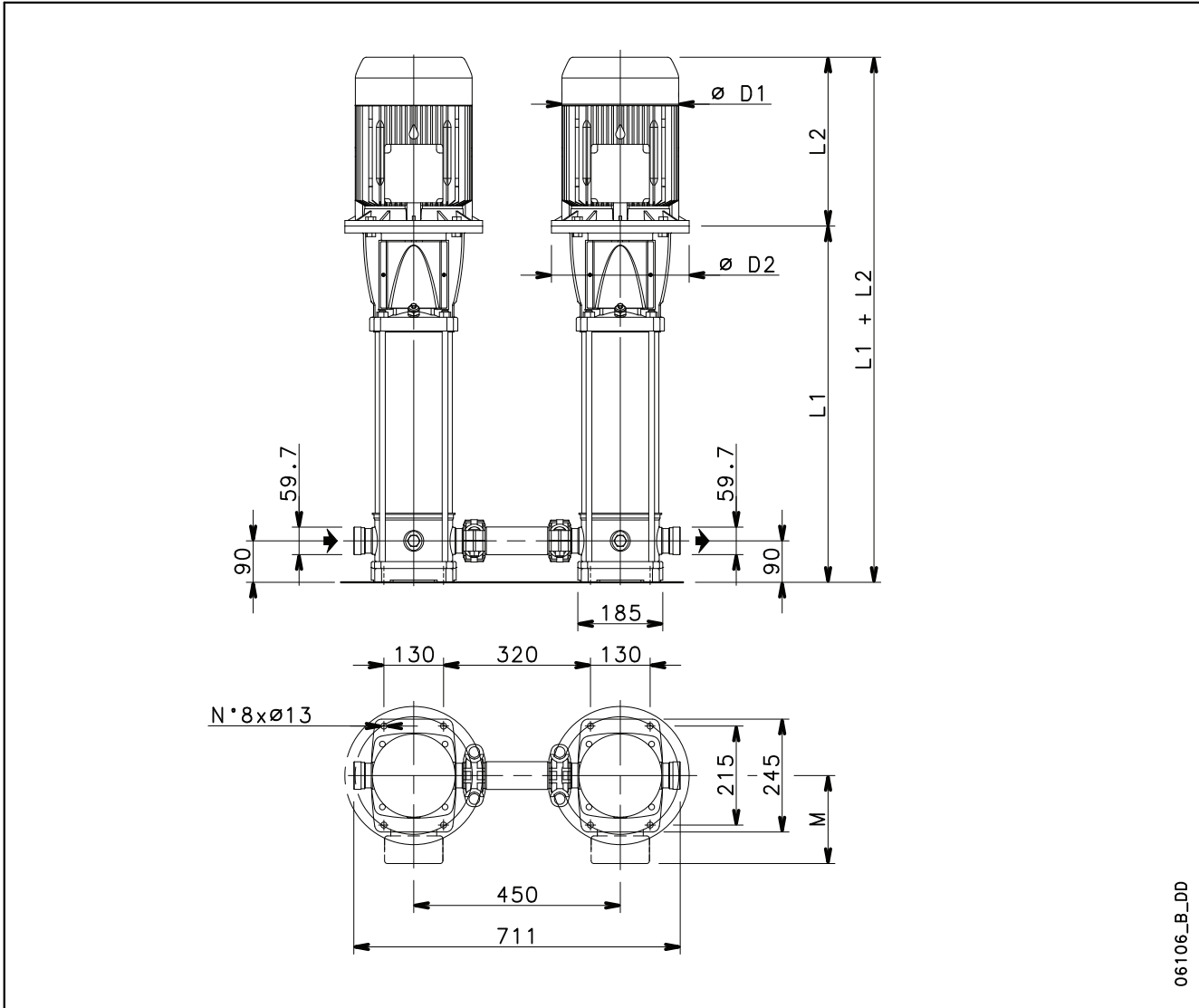
**10SV..P SERIES - HIGH PRESSURE
DIMENSIONS AND WEIGHTS AT 50 Hz, 2-POLE**

06106_B_DD

PUMP TYPE	MOTOR		DIMENSIONS (mm)					WEIGHT (Kg)	
	kW	Size	L1	L2	M	D1	D2	PUMP	ELECTRIC PUMP
10SV11P..	4	112	675	319	154	197	160	27,5	54
10SV13P..	5,5	132	806	375	168	214	300	35,8	74
10SV15P..	5,5	132	870	375	168	214	300	38,1	76
10SV17P..	7,5	132	934	367	191	256	300	40,4	97

Dimensions and weights are related to one electric pump.

10sv-p-2p50-en_d_td

**10SV..P SERIES - HIGH PRESSURE
OPERATING CHARACTERISTICS AT 50 Hz, 2-POLE**

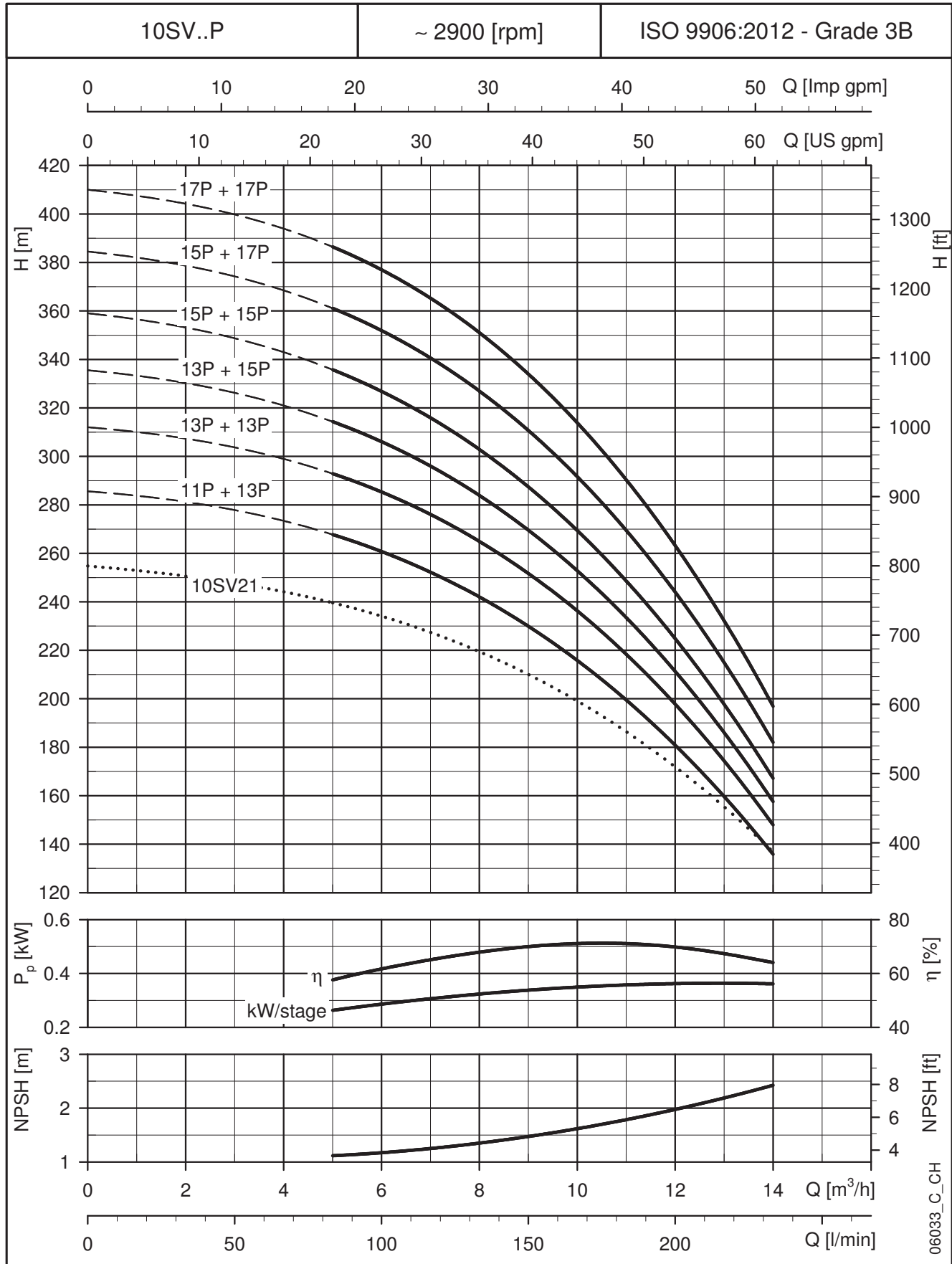

These performances are valid for liquids with density $\rho = 1.0 \text{ Kg/dm}^3$ and kinematic viscosity $\nu = 1 \text{ mm}^2/\text{sec}$.

**15SV..P SERIES - HIGH PRESSURE
DIMENSIONS AND WEIGHTS AT 50 Hz, 2-POLE**

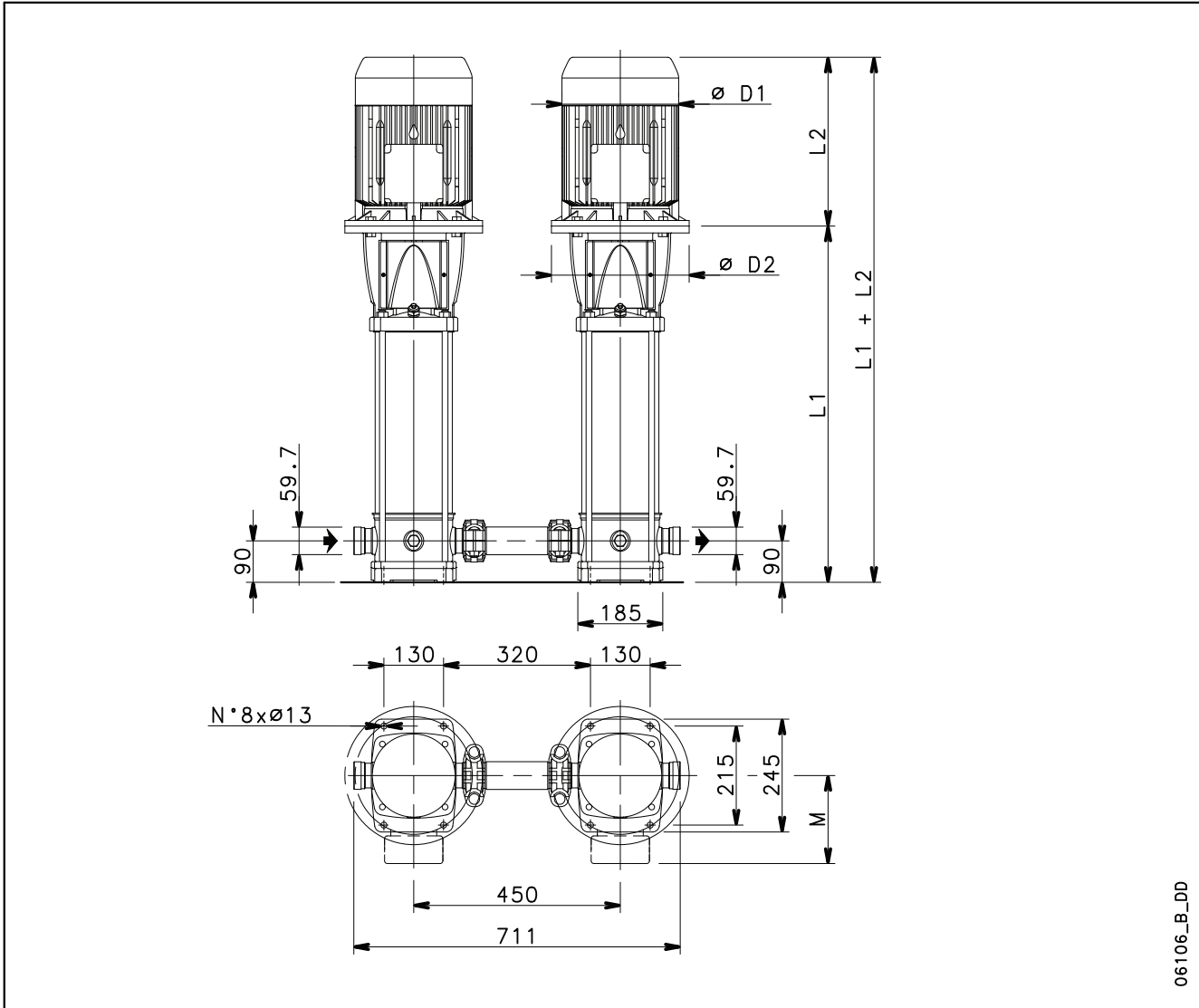

06106_B_DD

PUMP TYPE	MOTOR		DIMENSIONS (mm)					WEIGHT (Kg)	
	kW	Size	L1	L2	M	D1	D2	PUMP	ELECTRIC PUMP
15SV09P..	7,5	132	822	367	191	256	300	35,6	92
15SV10P..	11	160	900	428	191	256	350	40,1	111
15SV11P..	11	160	948	428	191	256	350	41,7	113
15SV13P..	11	160	1044	428	191	256	350	45	116
15SV15P..	15	160	1140	494	240	313	350	48,4	151

Dimensions and weights are related to one electric pump.

15sv-p-2p50-en_d_td

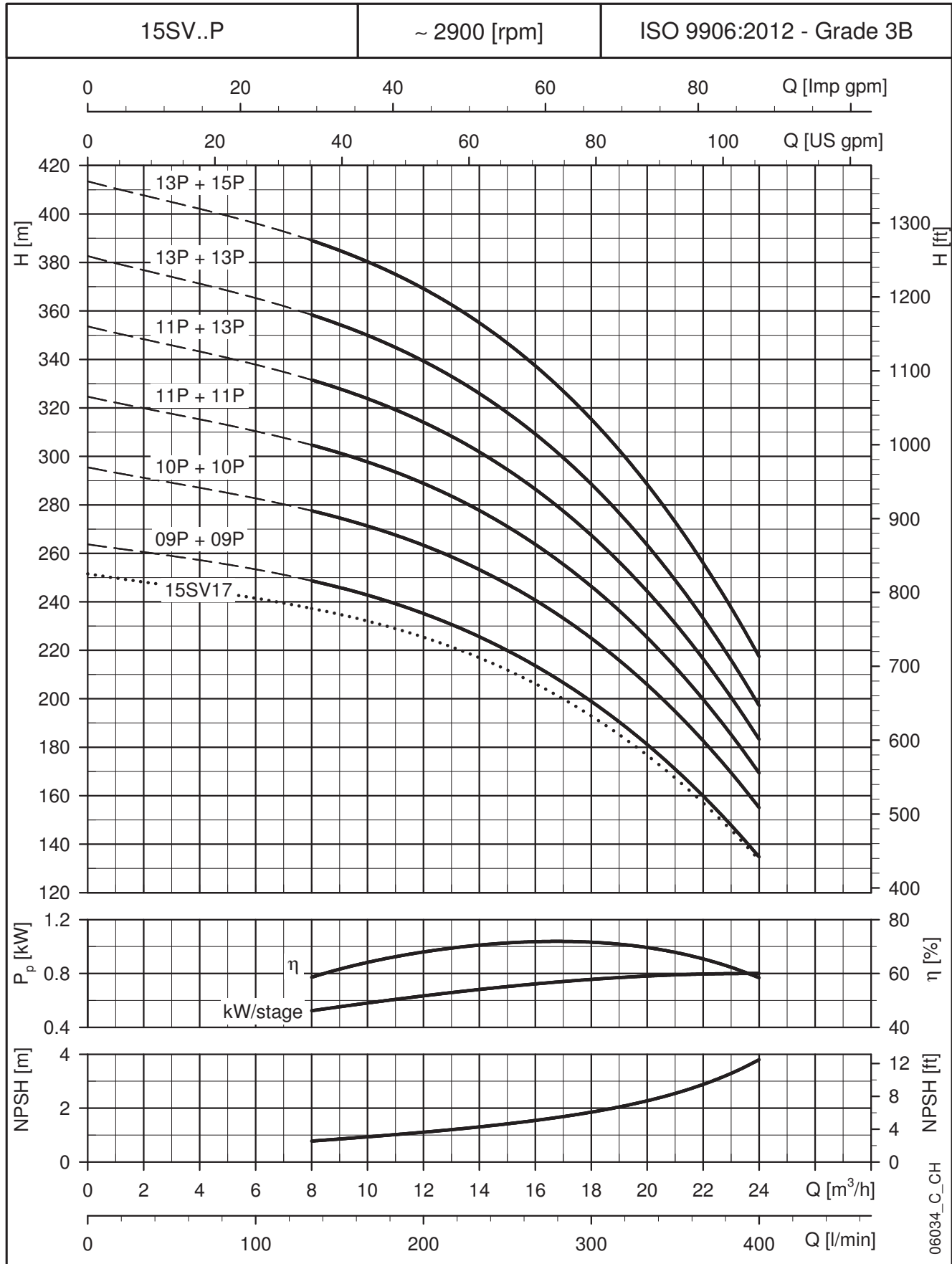
**15SV..P SERIES - HIGH PRESSURE
OPERATING CHARACTERISTICS AT 50 Hz, 2-POLE**

 These performances are valid for liquids with density $\rho = 1.0 \text{ Kg/dm}^3$ and kinematic viscosity $\nu = 1 \text{ mm}^2/\text{sec}$.

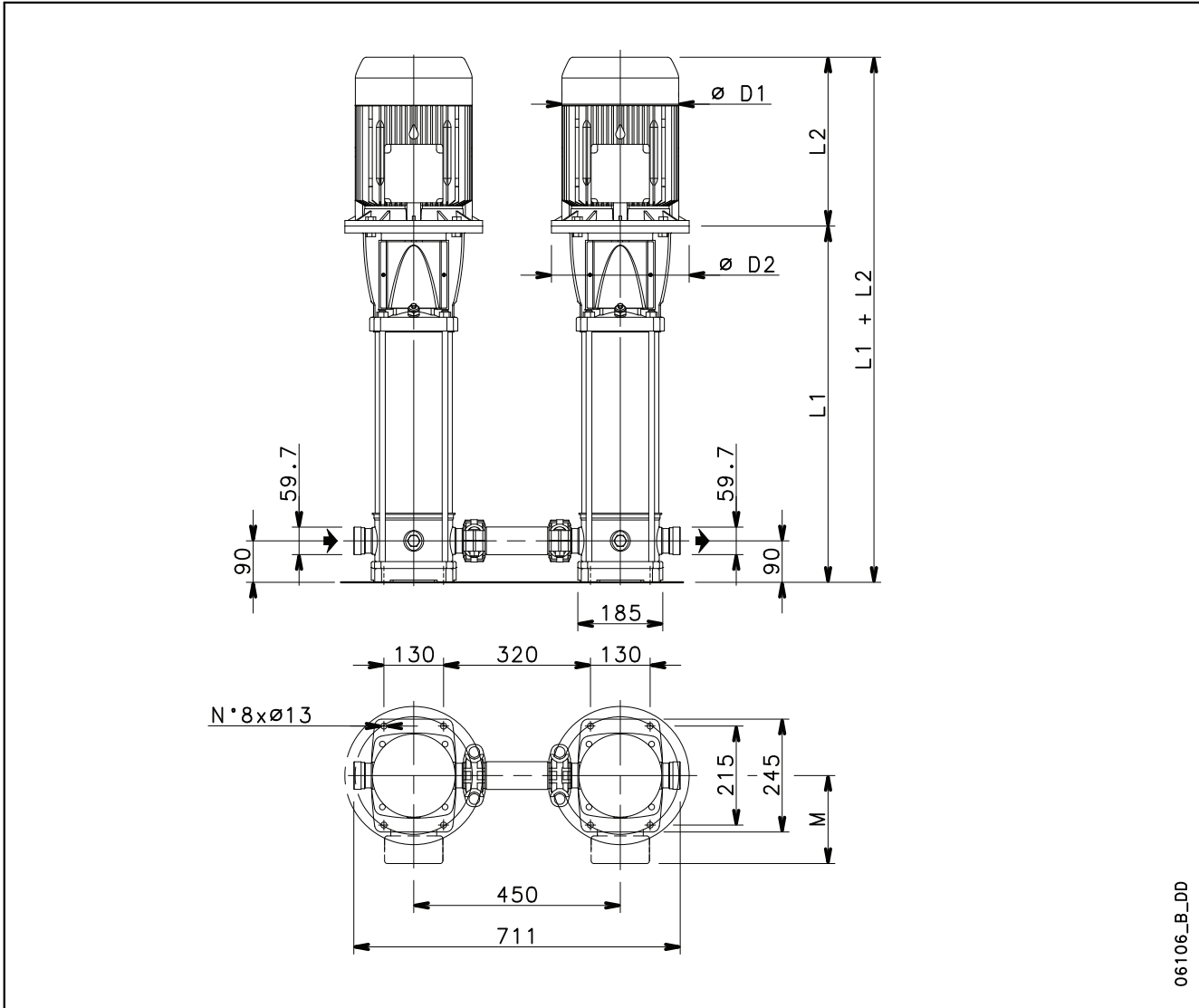
22SV..P SERIES - HIGH PRESSURE DIMENSIONS AND WEIGHTS AT 50 Hz, 2-POLE



06106_B_DD

PUMP TYPE	MOTOR		DIMENSIONS (mm)					WEIGHT (Kg)	
	kW	Size	L1	L2	M	D1	D2	PUMP	ELECTRIC PUMP
22SV09P..	11	160	852	428	191	256	350	37,2	108
22SV10P..	11	160	900	428	191	256	350	40	111
22SV12P..	15	160	996	494	240	313	350	42,2	145
22SV14P..	15	160	1092	494	240	313	350	45,5	148

Dimensions and weights are related to one electric pump.

22sv-p-2p50-en_b_td

**22SV..P SERIES - HIGH PRESSURE
OPERATING CHARACTERISTICS AT 50 Hz, 2-POLE**

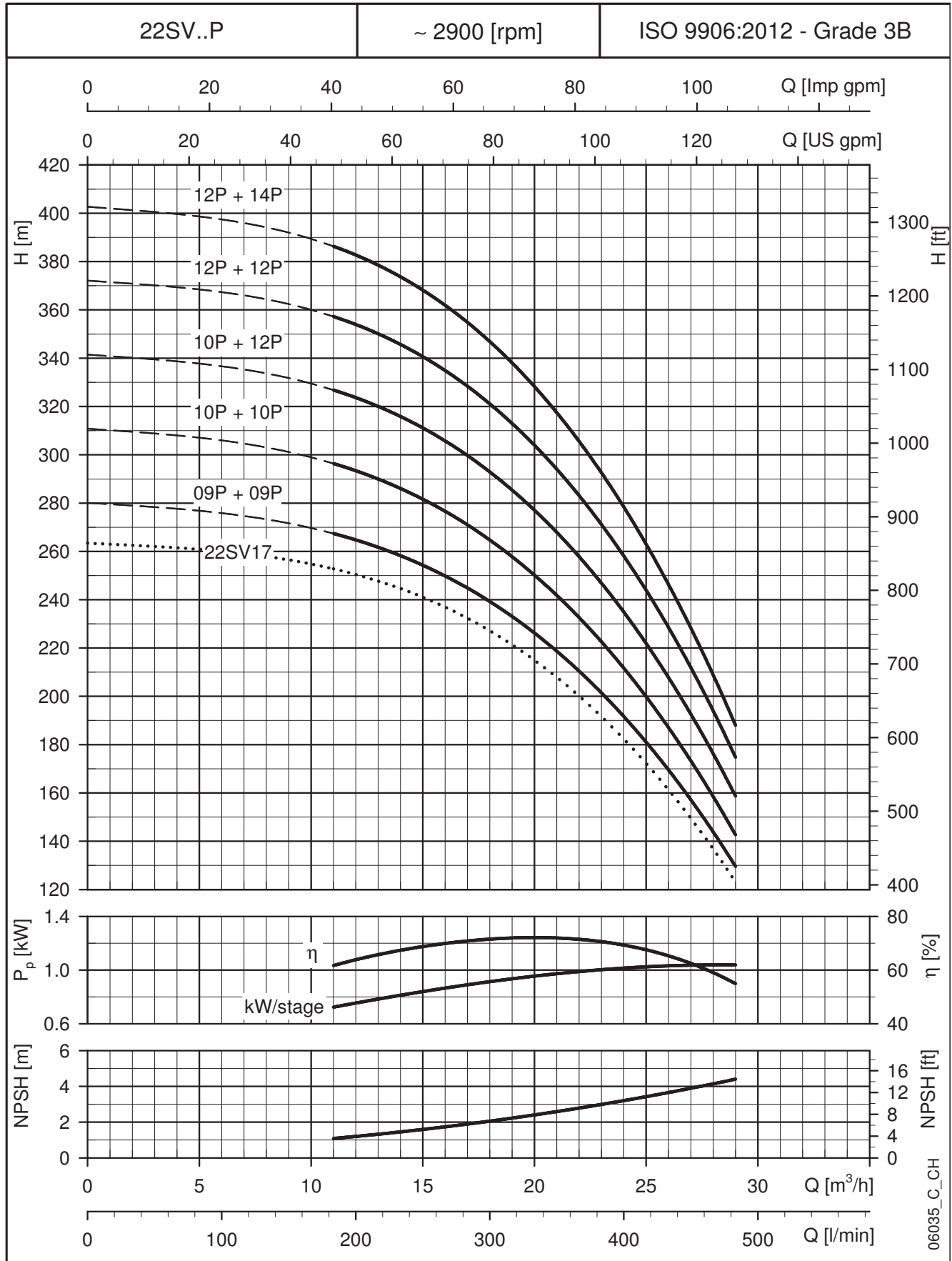

These performances are valid for liquids with density $\rho = 1.0 \text{ Kg/dm}^3$ and kinematic viscosity $\nu = 1 \text{ mm}^2/\text{sec}$.

33SV..P SERIES - HIGH PRESSURE DIMENSIONS AND WEIGHTS AT 50 Hz, 2-POLE

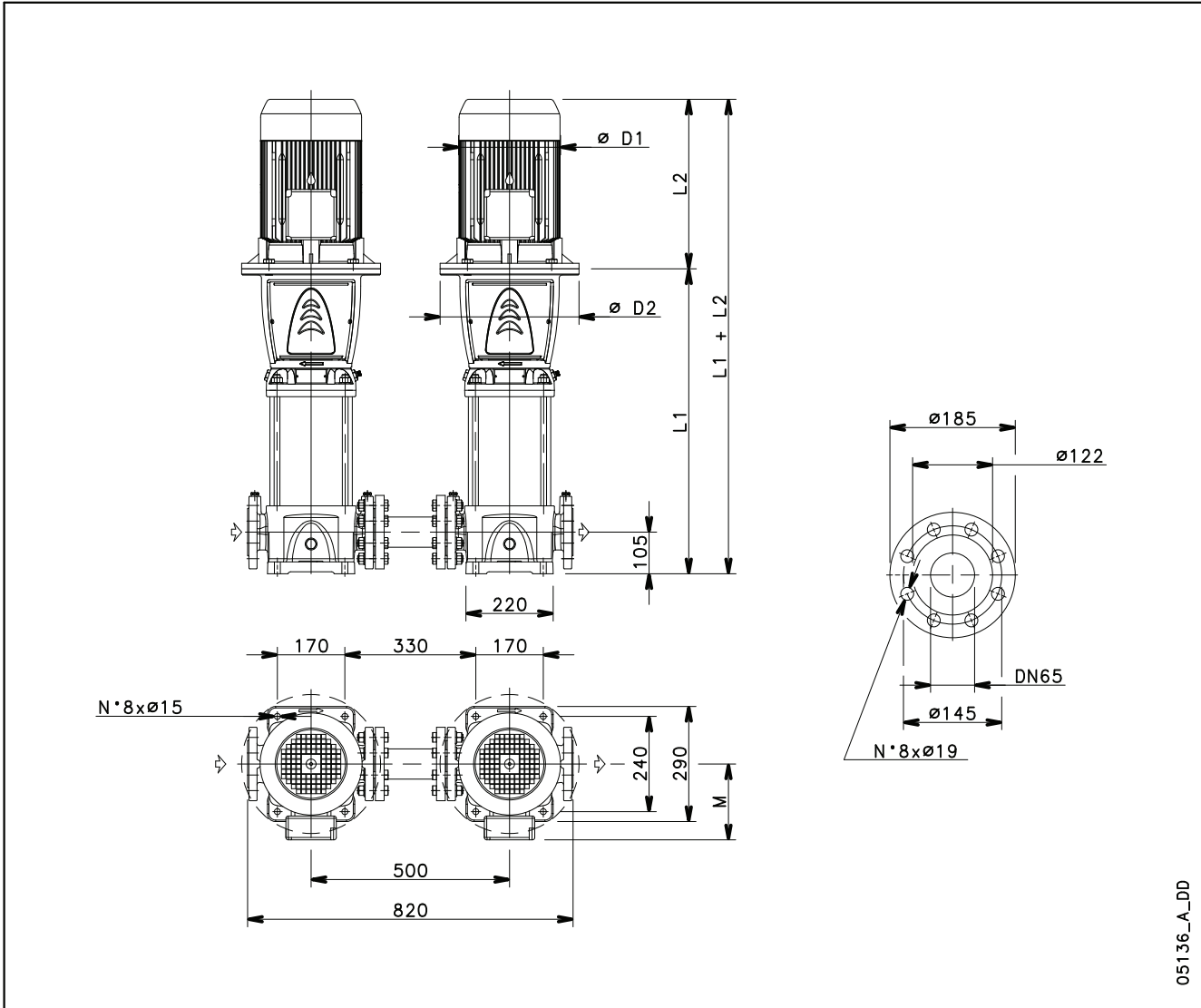

05136_A_DD

PUMP TYPE	MOTOR		DIMENSION (mm)					WEIGHT (Kg)	
	kW	Size	L1	L2	M	D1	D2	PUMP	ELECTRIC PUMP
33SV7/2AP..	15	160	994	494	240	313	350	88	190
33SV8/1AP..	18,5	160	1069	494	240	313	350	93	204
33SV9P..	22	180	1144	494	240	313	350	98	219

Dimensions and weights are related to one electric pump.

33sv-p-2p50-en_c_td

**33SV..P SERIES - HIGH PRESSURE
OPERATING CHARACTERISTICS AT 50 Hz, 2-POLE**

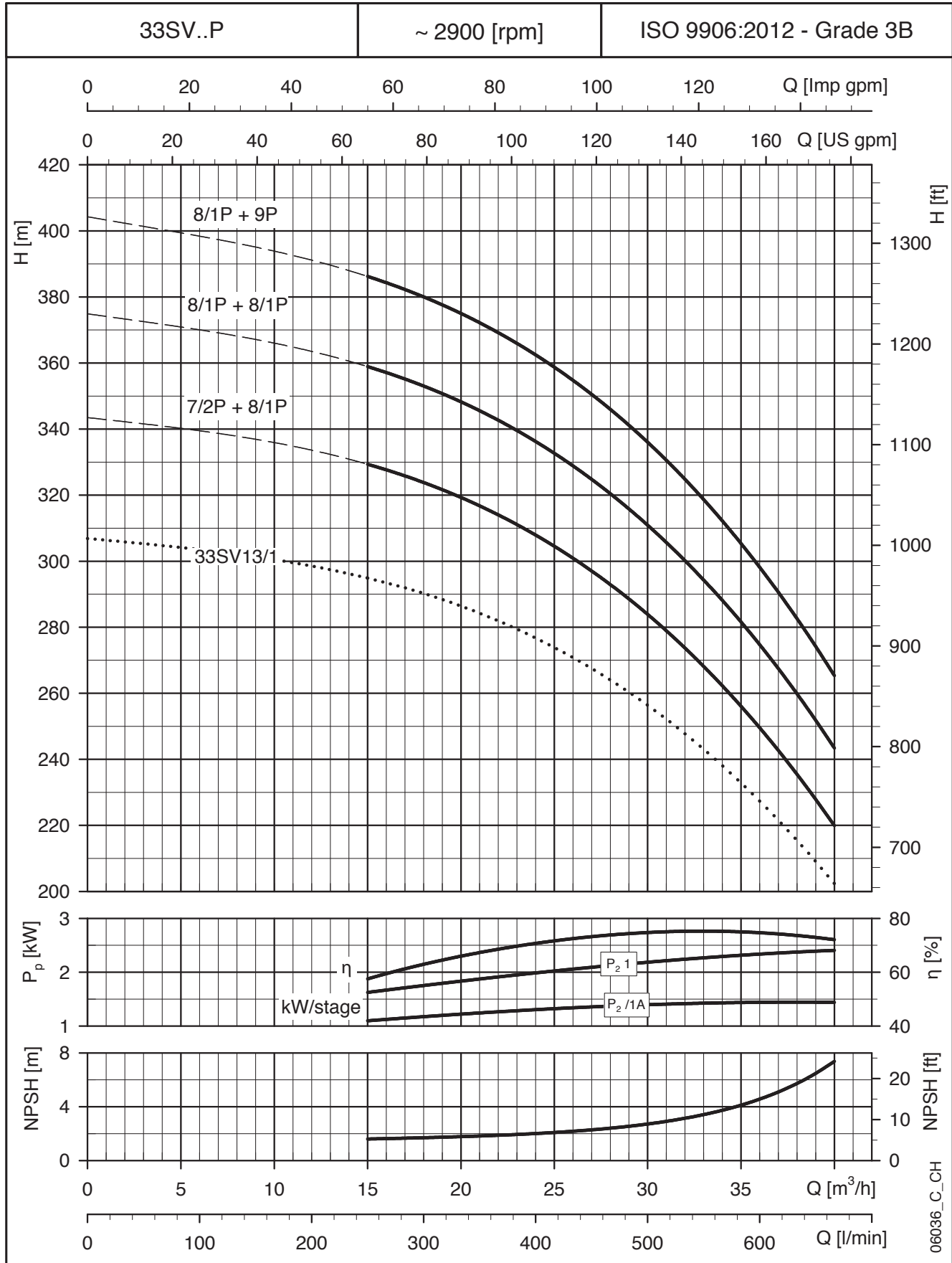

These performances are valid for liquids with density $\rho = 1.0 \text{ Kg/dm}^3$ and kinematic viscosity $\nu = 1 \text{ mm}^2/\text{sec}$.

**46SV..P SERIES - HIGH PRESSURE
DIMENSIONS AND WEIGHTS AT 50 Hz, 2-POLE**

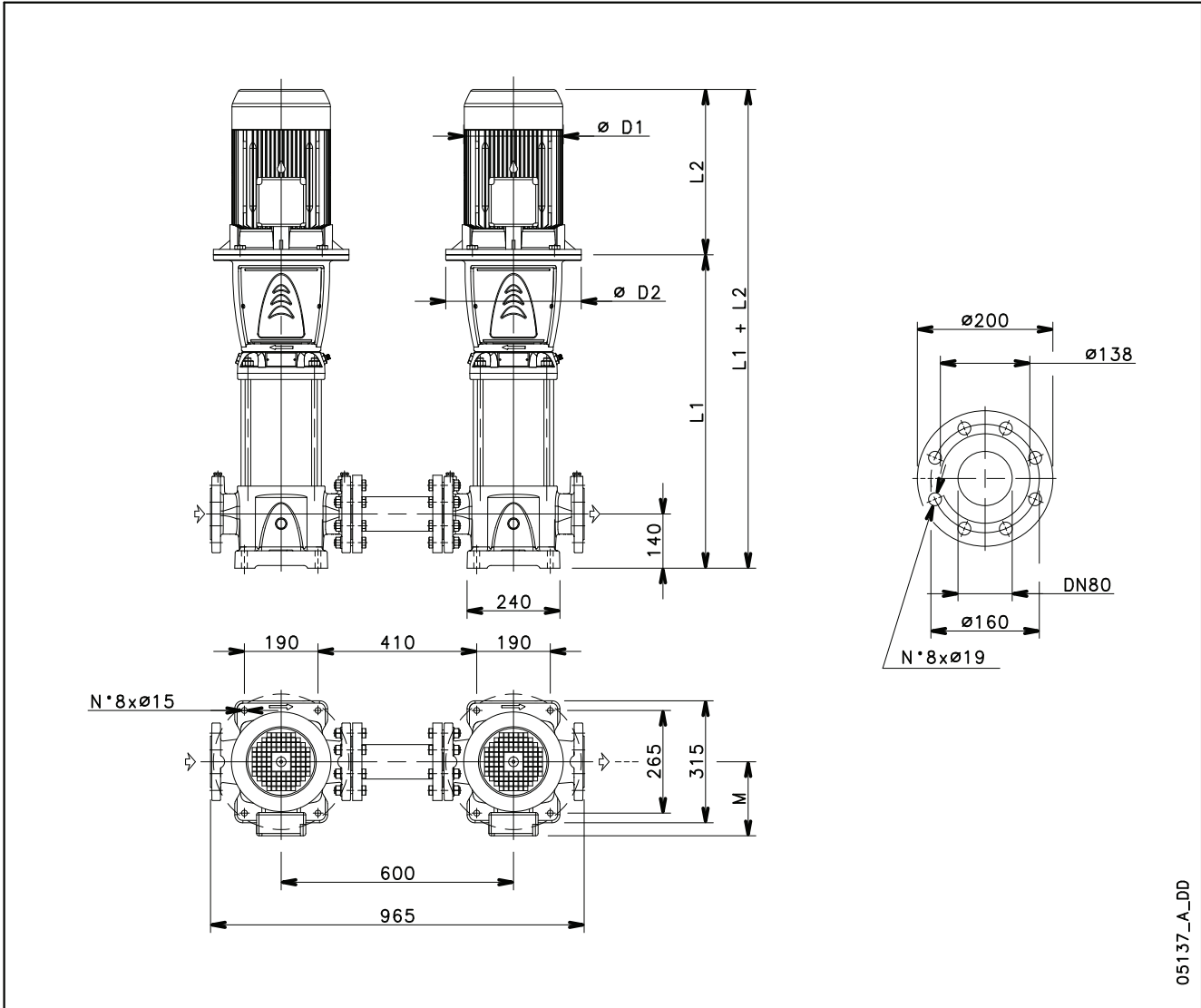

05137_A_DD

PUMP TYPE	MOTOR		DIMENSION (mm)					WEIGHT (Kg)	
	kW	Size	L1	L2	M	D1	D2	PUMP	ELECTRIC PUMP
46SV6P..	22	180	959	494	240	313	350	91	179
46SV7P..	30	200	1034	671	285	408	400	101	309
46SV8P..	30	200	1109	671	285	408	400	106	314

Dimensions and weights are related to one electric pump.

46sv-p-2p50-en_c_td

**46SV..P SERIES - HIGH PRESSURE
OPERATING CHARACTERISTICS AT 50 Hz, 2-POLE**

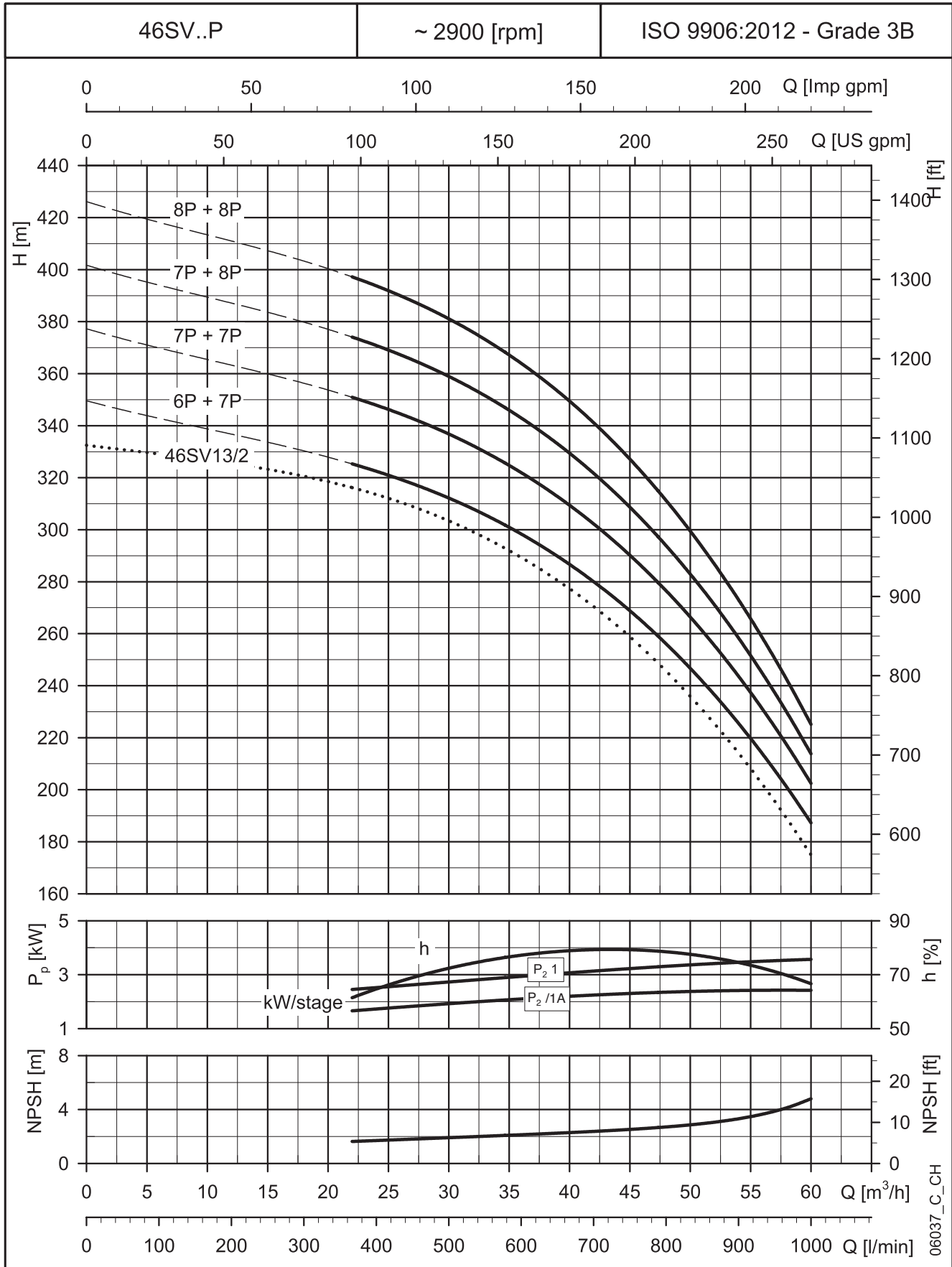

These performances are valid for liquids with density $\rho = 1.0 \text{ Kg/dm}^3$ and kinematic viscosity $\nu = 1 \text{ mm}^2/\text{sec}$.

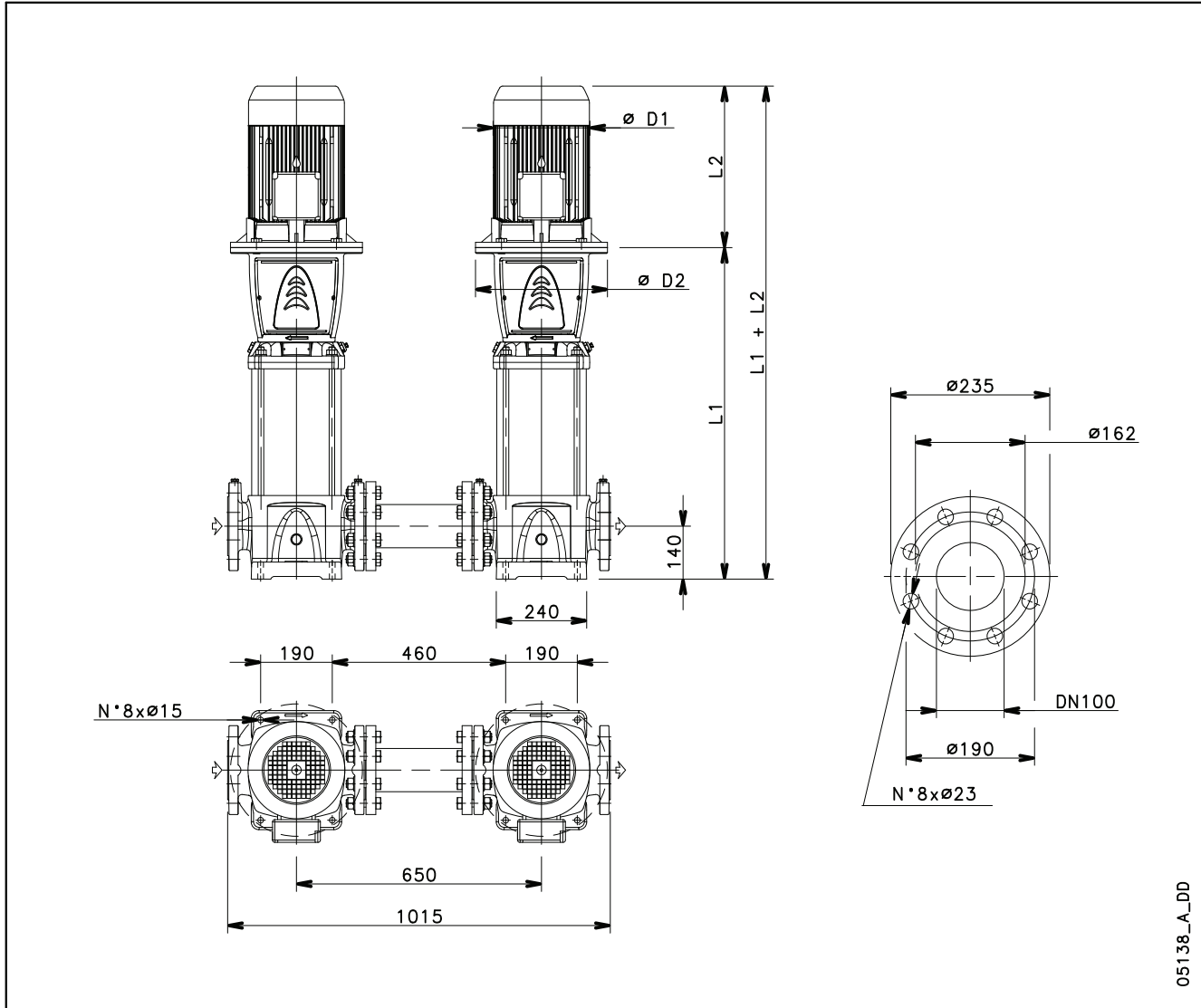
**66SV..P SERIES - HIGH PRESSURE
DIMENSIONS AND WEIGHTS AT 50 Hz, 2-POLE**

05138_A_DD

PUMP TYPE	MOTOR		DIMENSION (mm)					WEIGHT (Kg)	
	kW	Size	L1	L2	M	D1	D2	PUMP	ELECTRIC PUMP
66SV4P..	22	180	879	494	240	313	350	97	218
66SV5P..	30	200	969	671	285	408	400	110	318
66SV6/1AP..	30	200	1059	671	285	408	400	119	327
66SV7/1AP..	37	200	1149	671	285	408	400	125	349

Dimensions and weights are related to one electric pump.

66sv-p-2p50-en_c_td

**66SV..P SERIES - HIGH PRESSURE
OPERATING CHARACTERISTICS AT 50 Hz, 2-POLE**

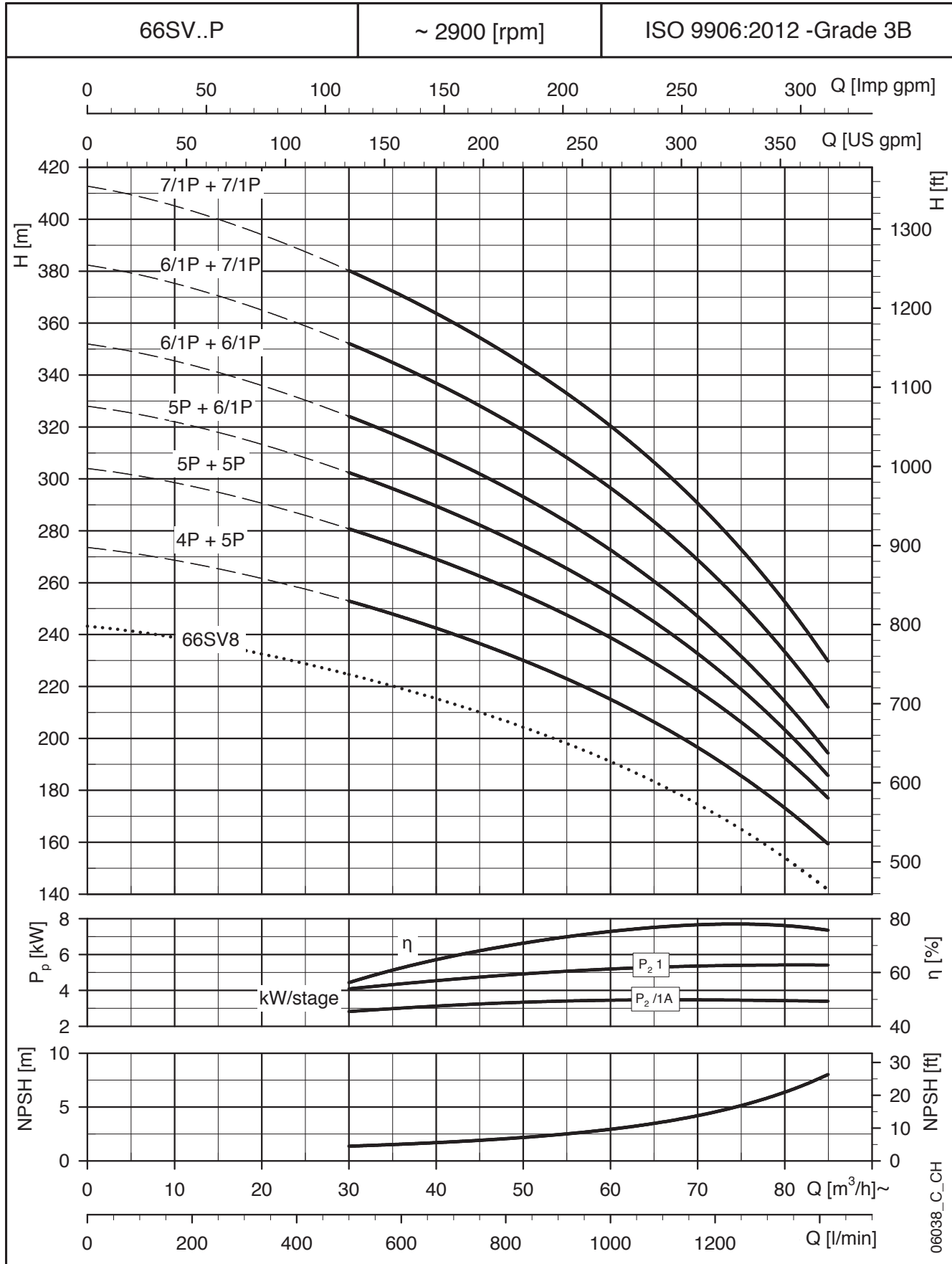

These performances are valid for liquids with density $\rho = 1.0 \text{ Kg/dm}^3$ and kinematic viscosity $\nu = 1 \text{ mm}^2/\text{sec}$.

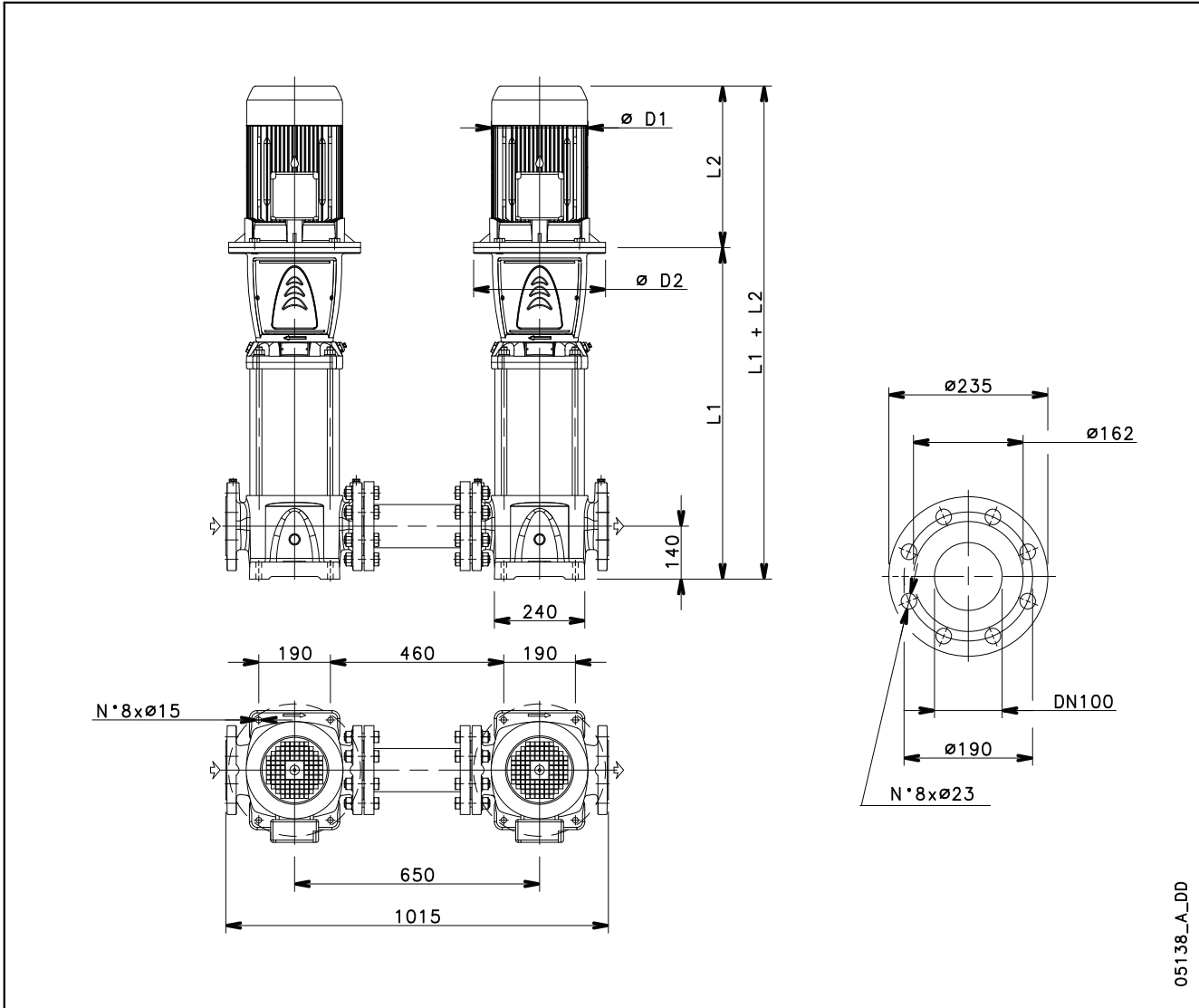
**92SV..P SERIES - HIGH PRESSURE
DIMENSIONS AND WEIGHTS AT 50 Hz, 2-POLE**

05138_A_DD

PUMP TYPE	MOTOR		DIMENSION (mm)					WEIGHT (Kg)	
	kW	Size	L1	L2	M	D1	D2	PUMP	ELECTRIC PUMP
92SV4/2AP..	30	200	879	671	285	408	400	103	311
92SV4P..	30	200	879	671	285	408	400	103	311
92SV5P..	37	200	969	671	285	408	400	112	336
92SV6P..	45	225	1059	701	309	460	450	122	414
92SV7/2AP..	55	250	1149	767	362	502	505	128	570

Dimensions and weights are related to one electric pump.

sj92sv-p-2p50-en_c_td

**92SV..P SERIES - HIGH PRESSURE
OPERATING CHARACTERISTICS AT 50 Hz, 2-POLE**

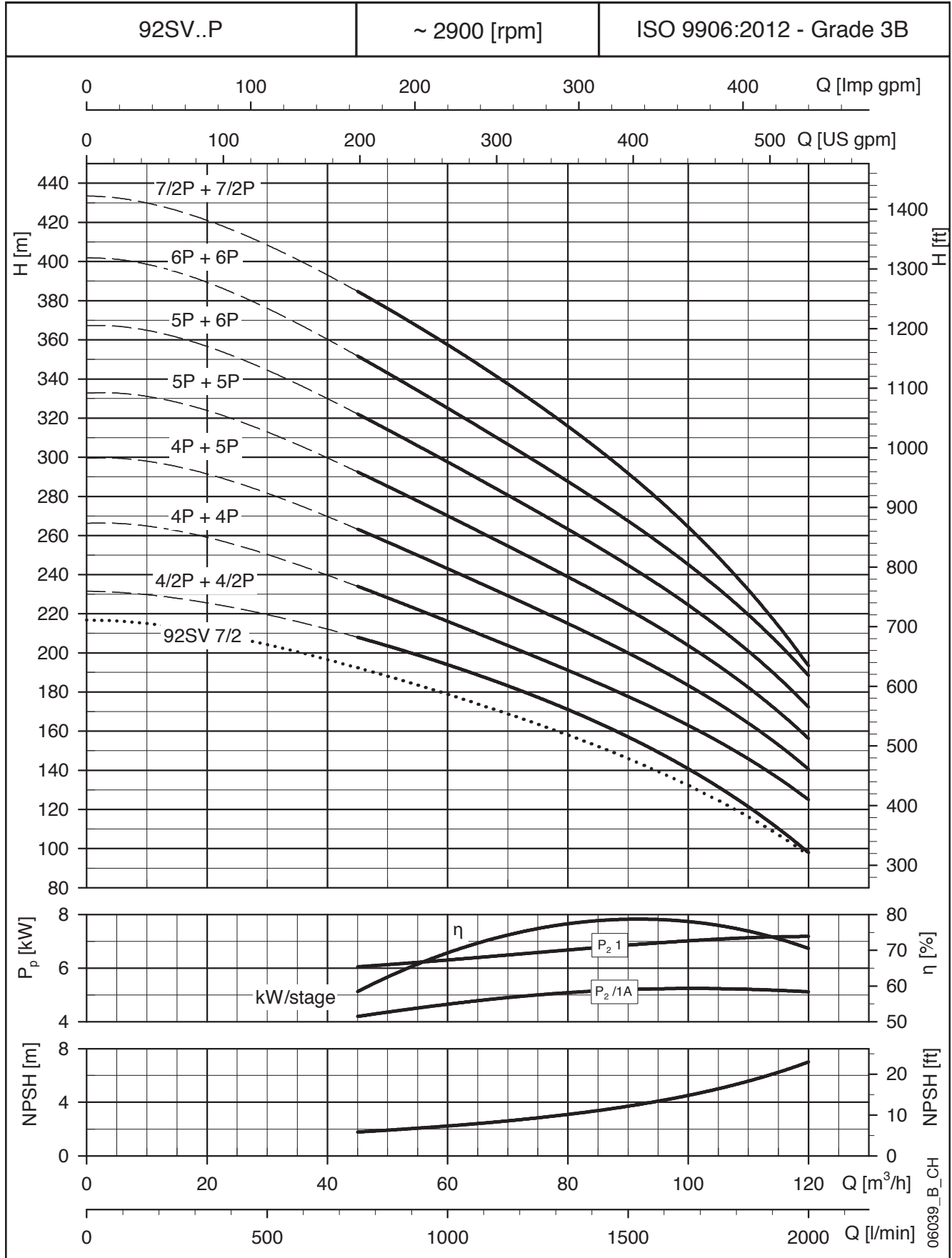

These performances are valid for liquids with density $\rho = 1.0 \text{ Kg/dm}^3$ and kinematic viscosity $\nu = 1 \text{ mm}^2/\text{sec}$.

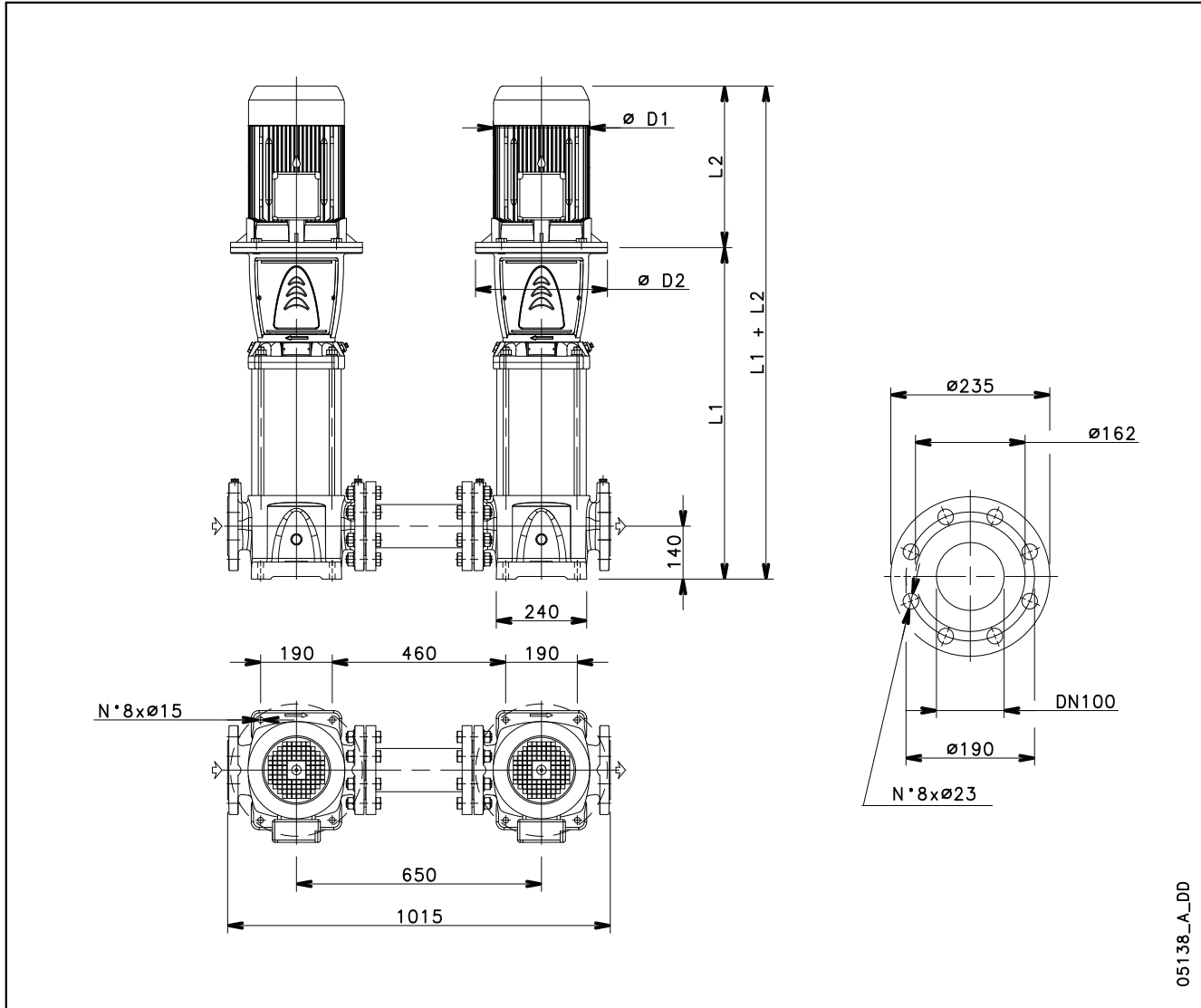
**125SV..P SERIES - HIGH PRESSURE
DIMENSIONS AND WEIGHTS AT 50 Hz, 2-POLE**

05138_A_DD

PUMP TYPE	MOTOR		DIMENSION (mm)					WEIGHT (Kg)	
	kW	Size	L1	L2	M	D1	D2	PUMP	ELECTRIC PUMP
125SV4P..	30	200	1178	671	285	408	400	168	376
125SV5P..	37	200	1328	671	285	408	400	181	405
125SV6P..	45	225	1478	701	309	460	450	198	490
125SV7P..	55	250	1658	767	362	502	550	228	670

Dimensions and weights are related to one electric pump.

125sv-p-2p50-en_c_td

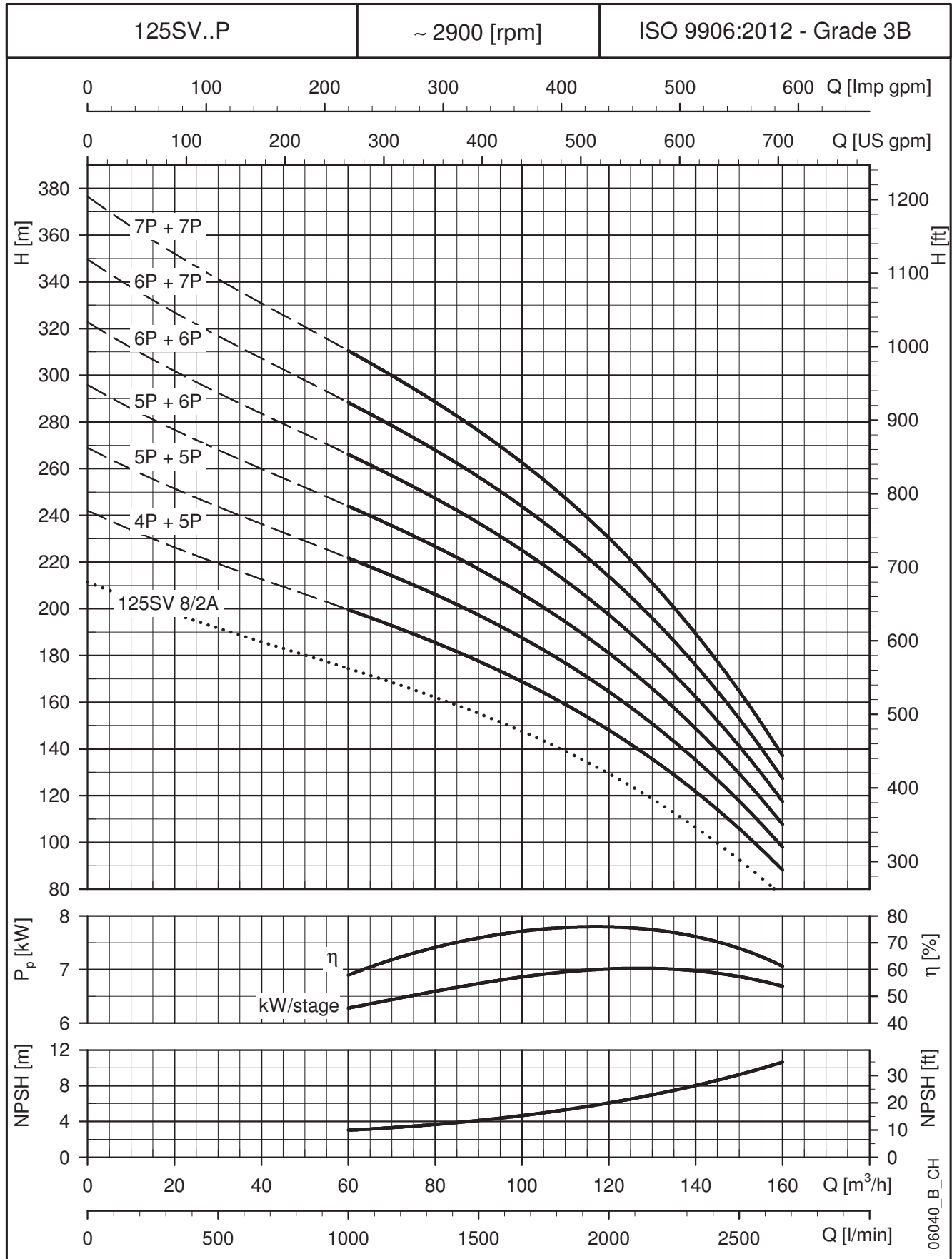
**125SV..P SERIES - HIGH PRESSURE
OPERATING CHARACTERISTICS AT 50 Hz, 2-POLE**

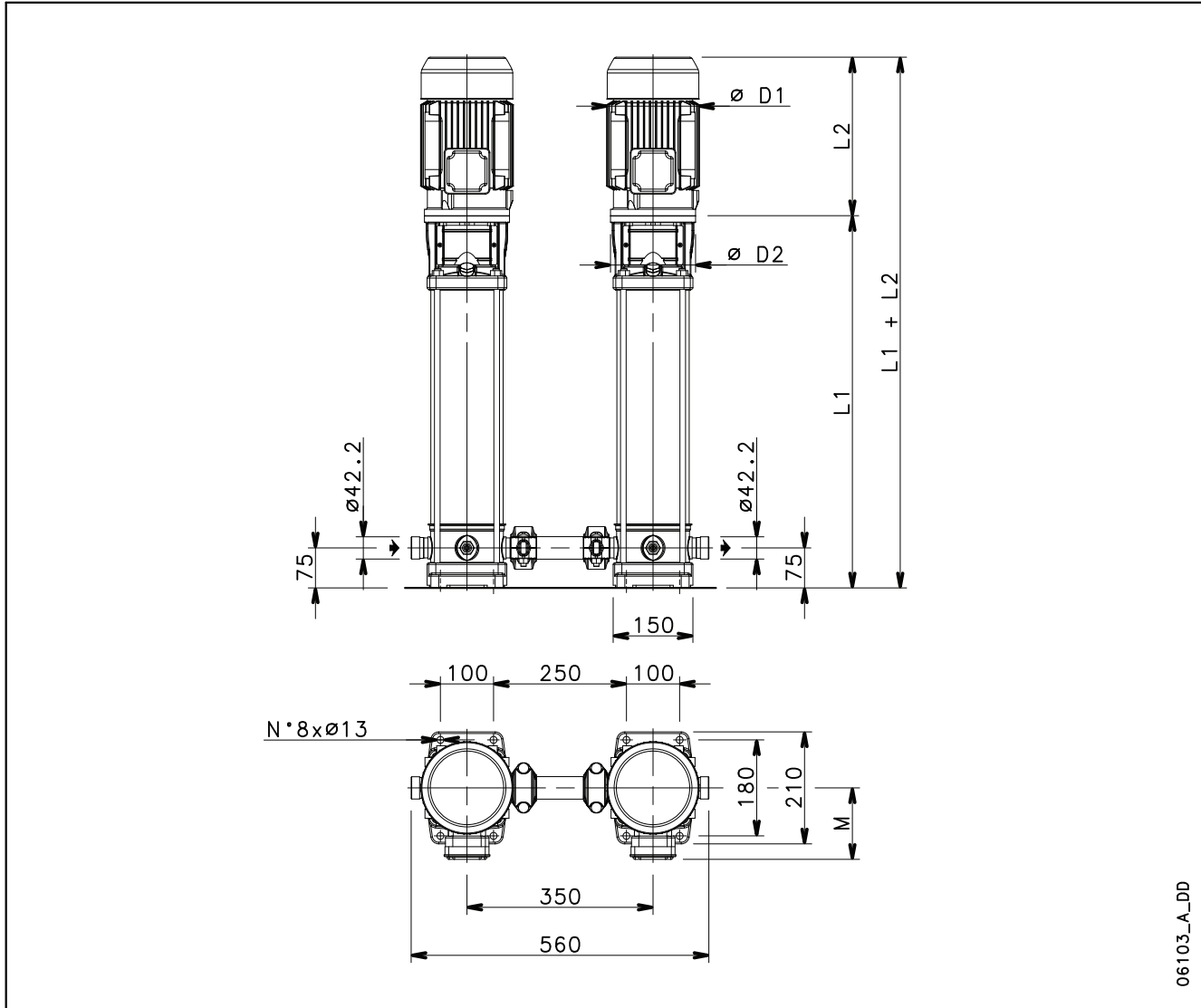
 These performances are valid for liquids with density $\rho = 1.0 \text{ Kg/dm}^3$ and kinematic viscosity $\nu = 1 \text{ mm}^2/\text{sec}$.

**1SV..P SERIES - HIGH PRESSURE
DIMENSIONS AND WEIGHTS AT 60 Hz, 2-POLE**

06103_A_DD

PUMP TYPE	MOTOR		DIMENSIONS (mm)					WEIGHT (Kg)	
	kW	Size	L1	L2	M	D1	D2	PUMP	ELECTRIC PUMP
1SV15P../D	1,5	90	558	263	129	155	140	15,8	28,8
1SV17P../D	1,5	90	598	263	129	155	140	16,8	28,8
1SV18P..	2,2	90	618	298	134	174	140	17,2	35,4
1SV20P..	2,2	90	658	298	134	174	140	18,2	36,4
1SV22P..	2,2	90	698	298	134	174	140	19,2	37,4
1SV24P..	2,2	90	738	298	134	174	140	20,1	38,3

Dimensions and weights are related to one electric pump.

1sv-p-2p60-en_d_td

**1SV..P SERIES - HIGH PRESSURE
OPERATING CHARACTERISTICS AT 60 Hz, 2-POLE**

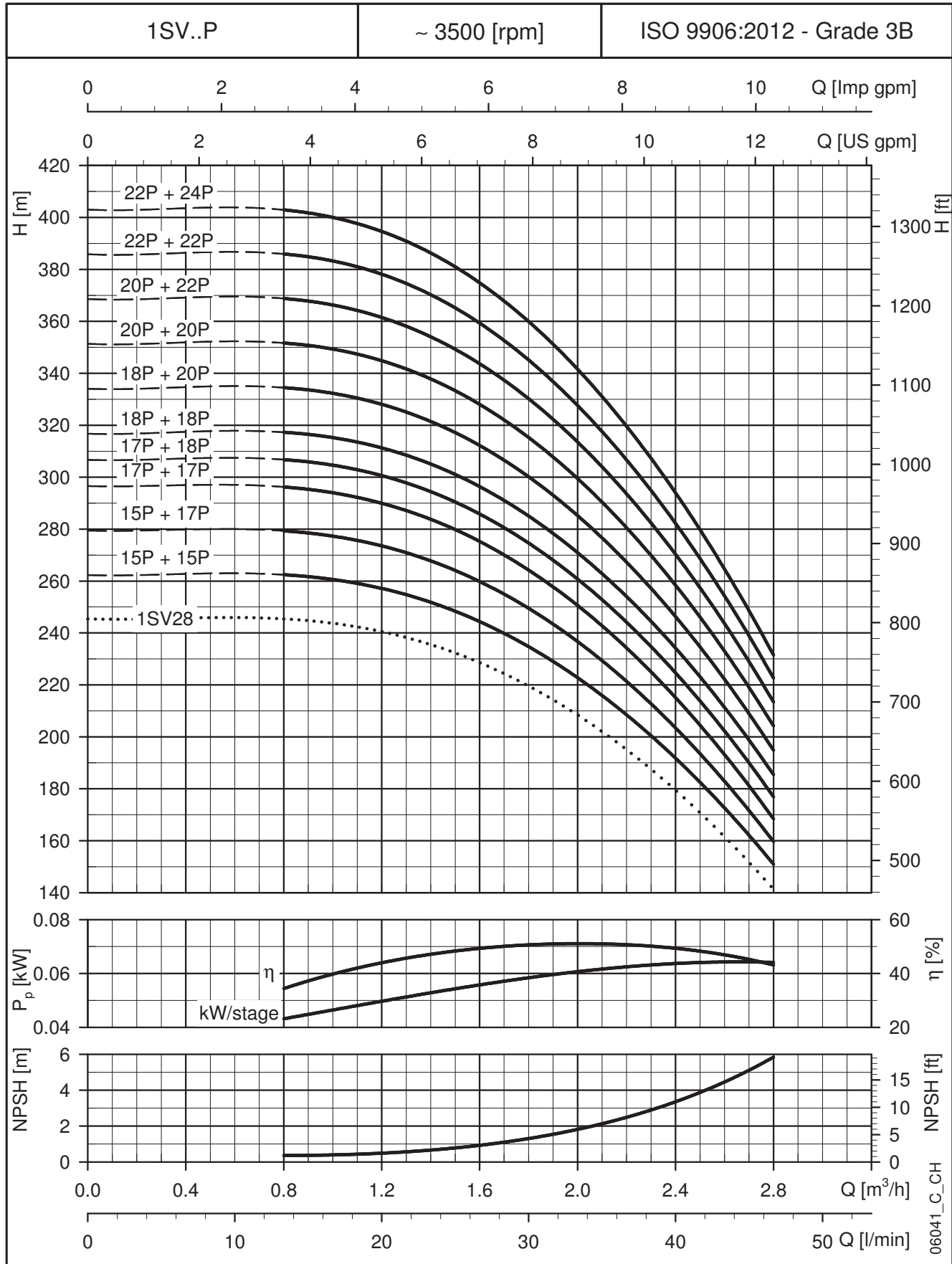

These performances are valid for liquids with density $\rho = 1.0 \text{ Kg/dm}^3$ and kinematic viscosity $\nu = 1 \text{ mm}^2/\text{sec}$.

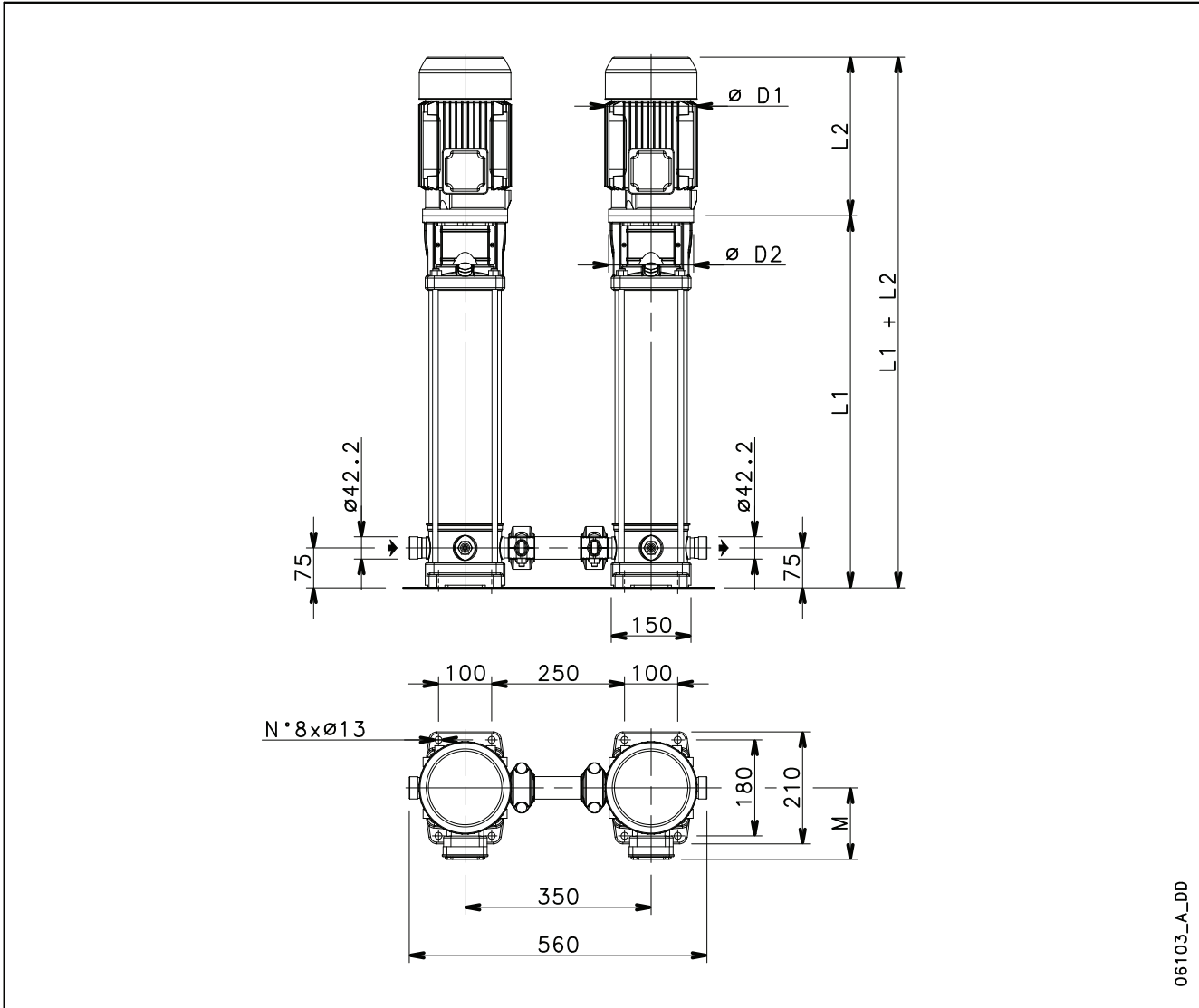
**3SV..P SERIES - HIGH PRESSURE
DIMENSIONS AND WEIGHTS AT 60 Hz, 2-POLE**

PUMP TYPE	MOTOR		DIMENSIONS (mm)					WEIGHT (Kg)	
	kW	Size	L1	L2	M	D1	D2	PUMP	ELECTRIC PUMP
3SV12P..	2,2	90	498	298	134	174	140	14,2	32,4
3SV13P..	2,2	90	518	298	134	174	140	14,7	32,9
3SV14P..	2,2	90	538	298	134	174	140	15,2	33,4
3SV15P..	3	100	568	298	134	174	160	16,1	37,1
3SV17P..	3	100	608	298	134	174	160	17	38
3SV19P..	3	100	648	298	134	174	160	18	39

Dimensions and weights are related to one electric pump.

3sv-p-2p60-en_d_td

**3SV..P SERIES - HIGH PRESSURE
OPERATING CHARACTERISTICS AT 60 Hz, 2-POLE**

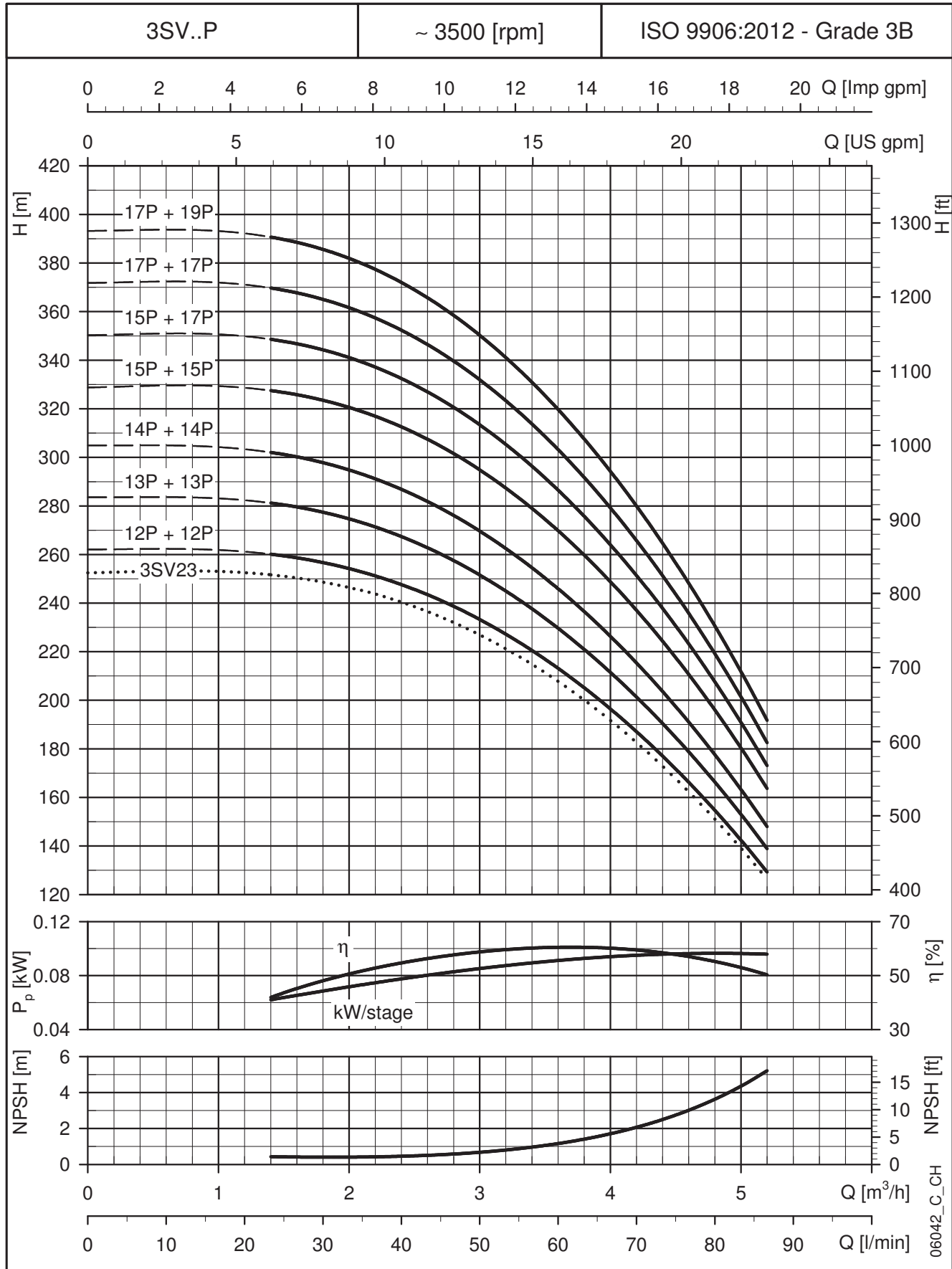

These performances are valid for liquids with density $\rho = 1.0 \text{ Kg/dm}^3$ and kinematic viscosity $\nu = 1 \text{ mm}^2/\text{sec}$.

5SV..P SERIES - HIGH PRESSURE DIMENSIONS AND WEIGHTS AT 60 Hz, 2-POLE

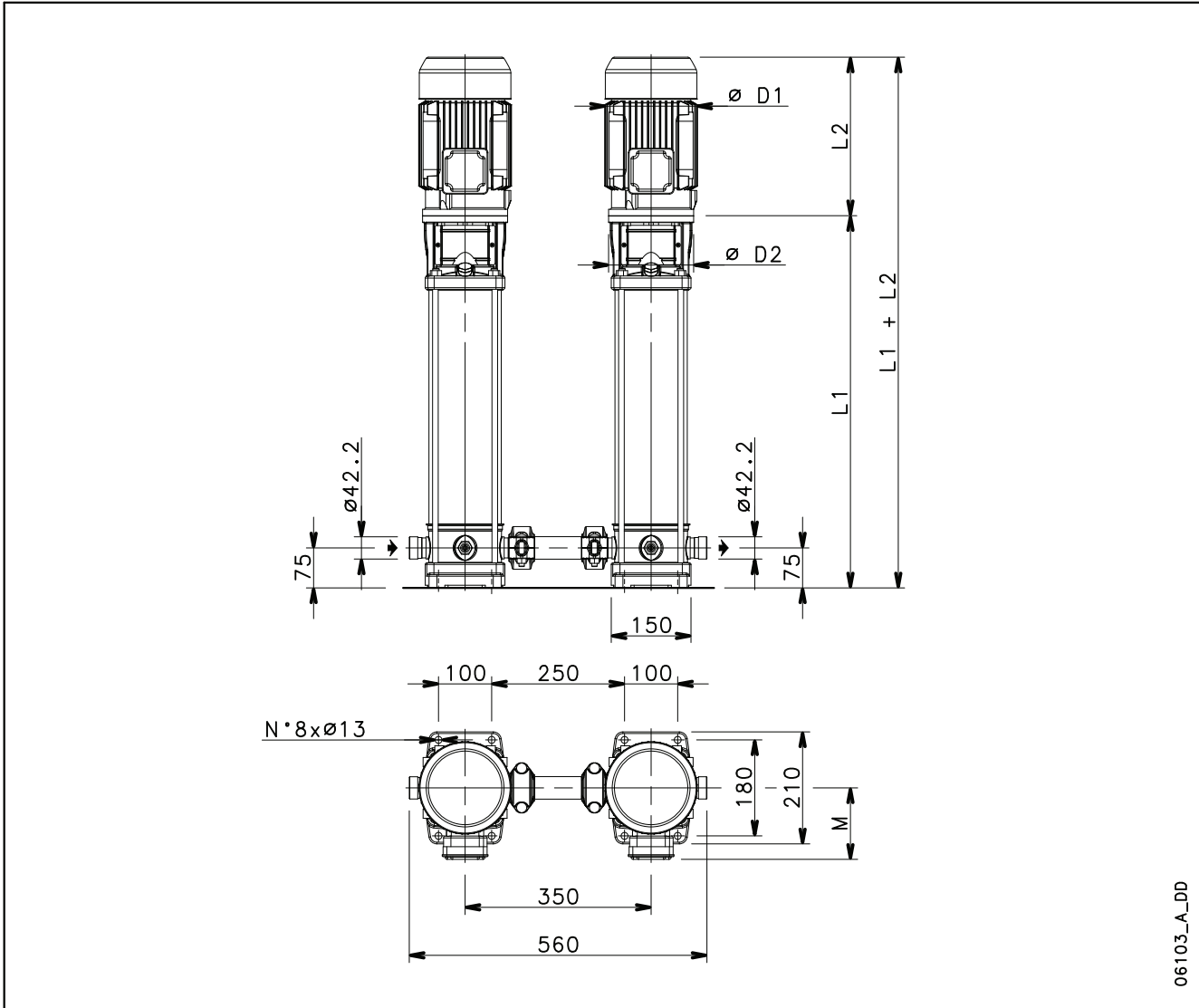

06103_A_DD

PUMP TYPE	MOTOR		DIMENSIONS (mm)					WEIGHT (Kg)	
	kW	Size	L1	L2	M	D1	D2	PUMP	ELECTRIC PUMP
5SV12P..	3	100	573	298	134	174	160	16,2	37,2
5SV13P..	4	112	598	319	154	197	160	16,8	43,2
5SV14P..	4	112	623	319	154	197	160	17,3	43,7
5SV15P..	4	112	648	319	154	197	160	17,9	44,3
5SV16P..	4	112	673	319	154	197	160	18,5	44,9
5SV17P..	5,5	132	718	375	168	214	300	23	61
5SV19P..	5,5	132	768	375	168	214	300	24	62

Dimensions and weights are related to one electric pump.

5sv-p-2p60-en_d_td

**5SV..P SERIES - HIGH PRESSURE
OPERATING CHARACTERISTICS AT 60 Hz, 2-POLE**

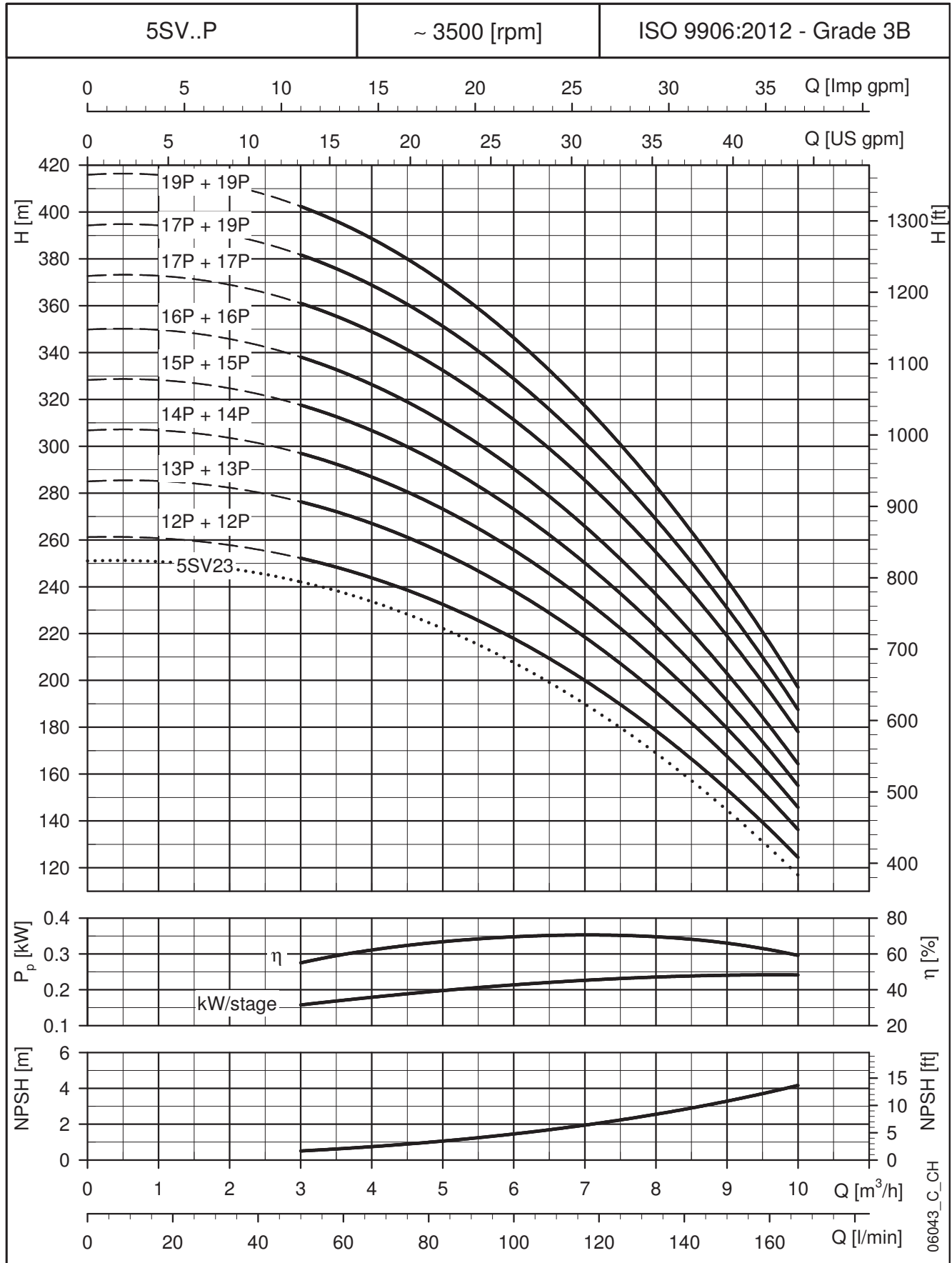

These performances are valid for liquids with density $\rho = 1.0 \text{ Kg/dm}^3$ and kinematic viscosity $\nu = 1 \text{ mm}^2/\text{sec}$.

10SV..P SERIES - HIGH PRESSURE DIMENSIONS AND WEIGHTS AT 60 Hz, 2-POLE

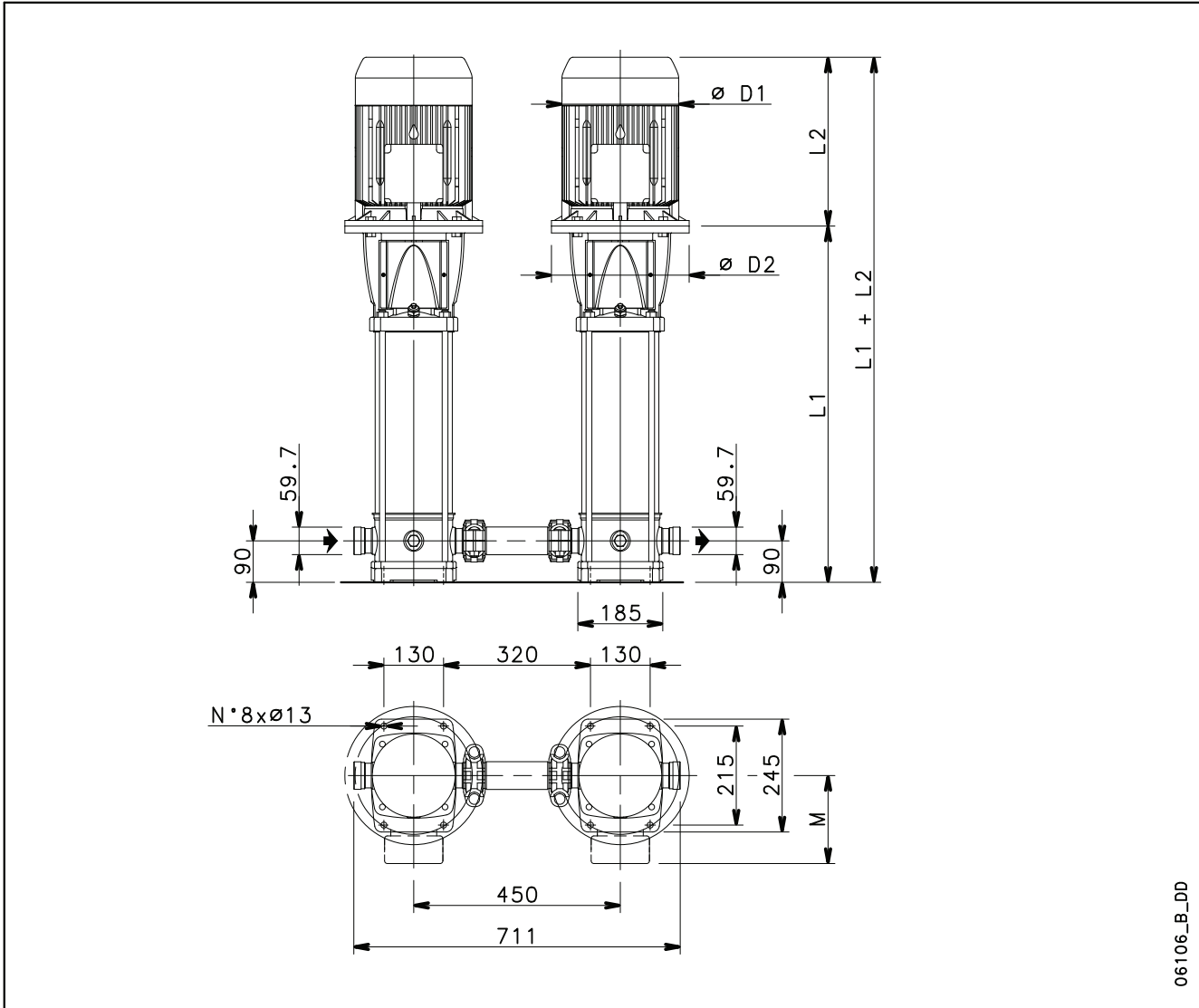

06106_B_DD

PUMP TYPE	MOTOR		DIMENSIONS (mm)					WEIGHT (Kg)	
	kW	Size	L1	L2	M	D1	D2	PUMP	ELECTRIC PUMP
10SV08P..	5,5	132	646	375	168	214	300	28,6	66
10SV09P..	7,5	132	678	367	191	256	300	29,8	86
10SV10P..	7,5	132	710	367	191	256	300	30,9	87
10SV11P..	7,5	132	742	367	191	256	300	32	88
10SV13P..	11	160	836	428	191	256	350	37,1	108

Dimensions and weights are related to one electric pump.

10sv-p-2p60-en_c_td

**10SV..P SERIES - HIGH PRESSURE
OPERATING CHARACTERISTICS AT 60 Hz, 2-POLE**

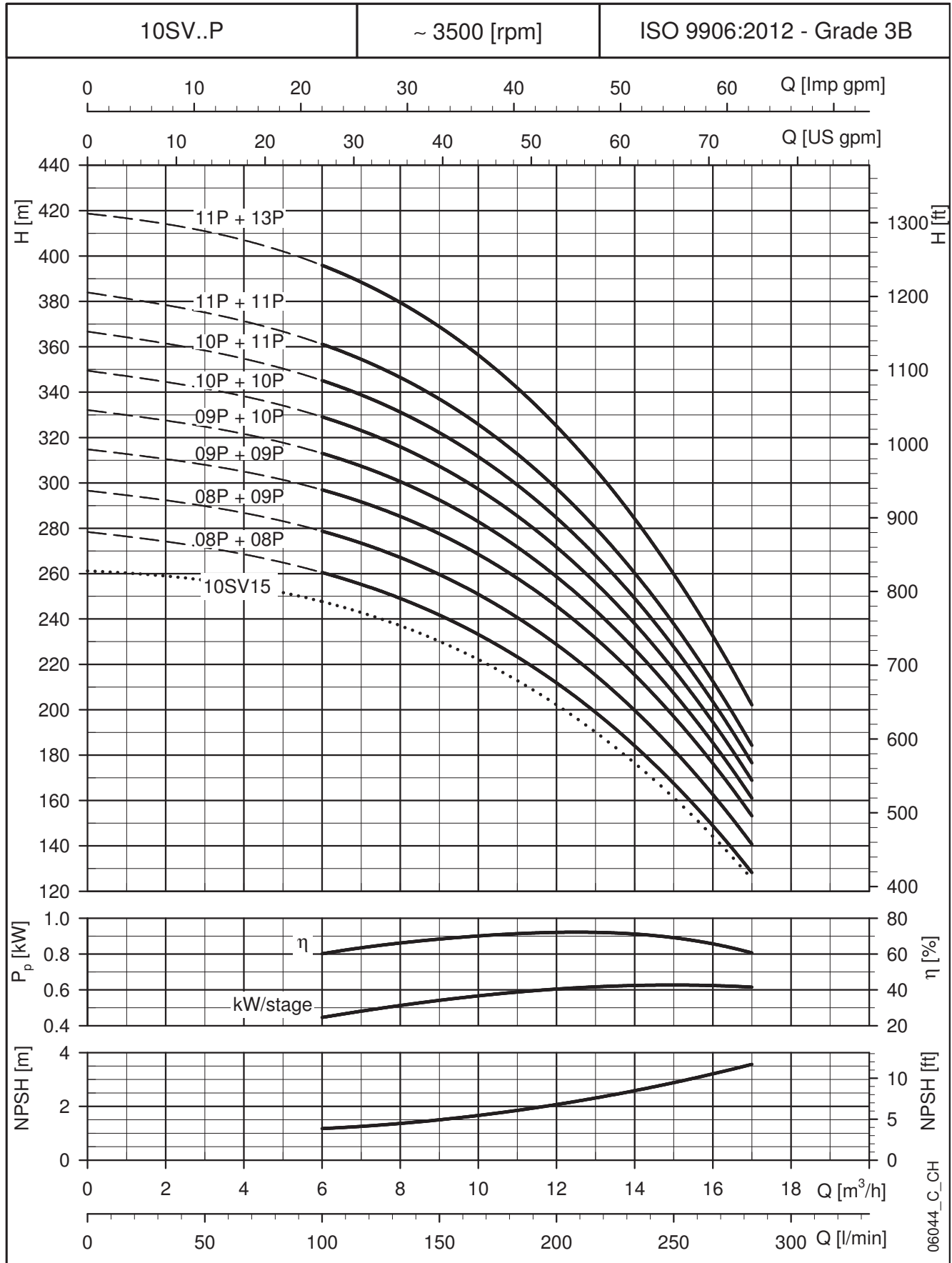

These performances are valid for liquids with density $\rho = 1.0 \text{ Kg/dm}^3$ and kinematic viscosity $\nu = 1 \text{ mm}^2/\text{sec}$.

**15SV..P SERIES - HIGH PRESSURE
DIMENSIONS AND WEIGHTS AT 60 Hz, 2-POLE**

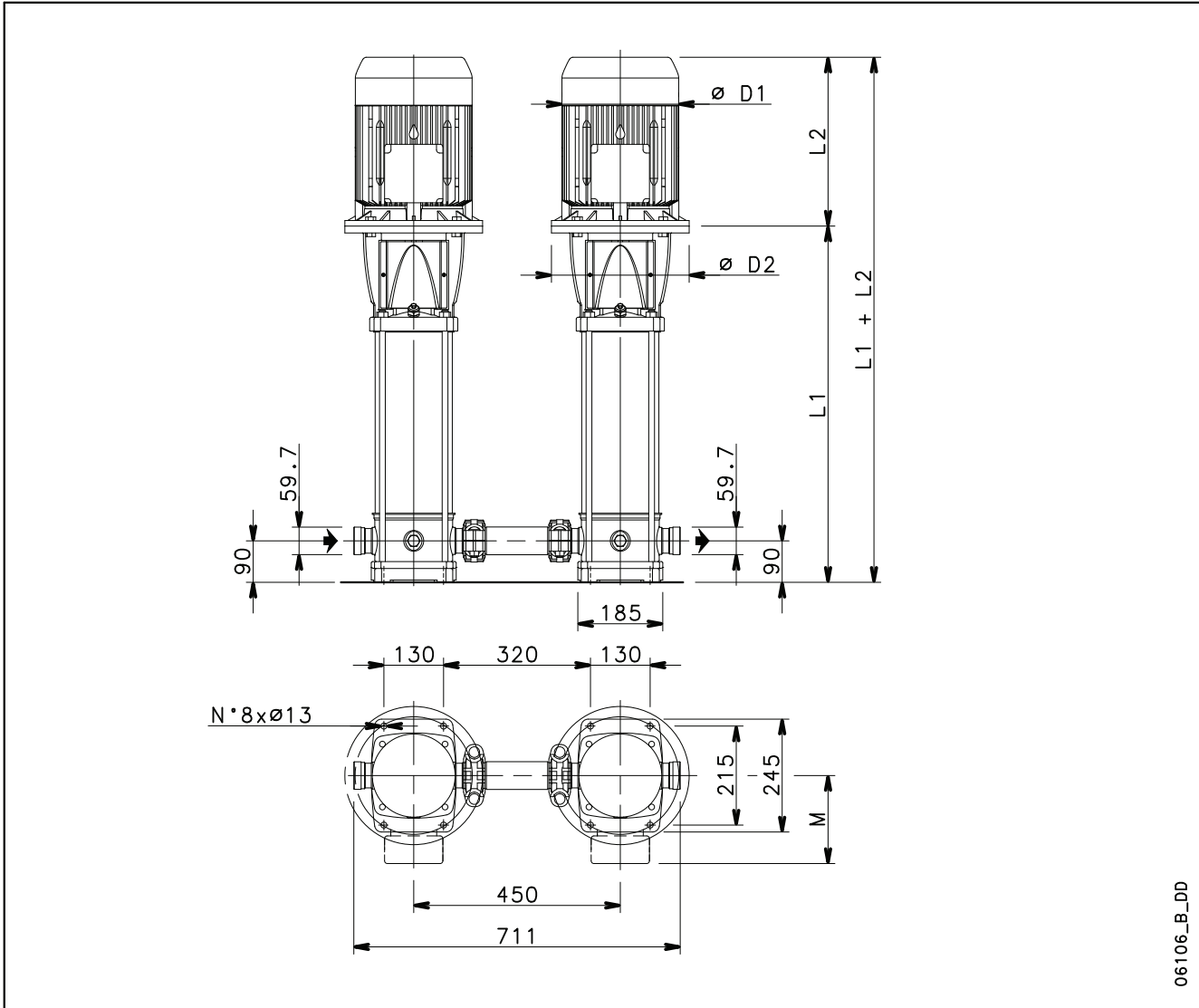

06106_B_DD

PUMP TYPE	MOTOR		DIMENSIONS (mm)					WEIGHT (Kg)	
	kW	Size	L1	L2	M	D1	D2	PUMP	ELECTRIC PUMP
15SV06P..	11	160	708	428	191	256	350	32,5	103
15SV07P..	11	160	756	428	191	256	350	34,5	105
15SV08P..	15	160	804	494	240	313	350	36	139
15SV09P..	15	160	852	494	240	313	350	37,5	140
15SV10P..	15	160	900	494	240	313	350	39,5	141

Dimensions and weights are related to one electric pump.

15sv-p-2p60-en_c_td

**15SV..P SERIES - HIGH PRESSURE
OPERATING CHARACTERISTICS AT 60 Hz, 2-POLE**

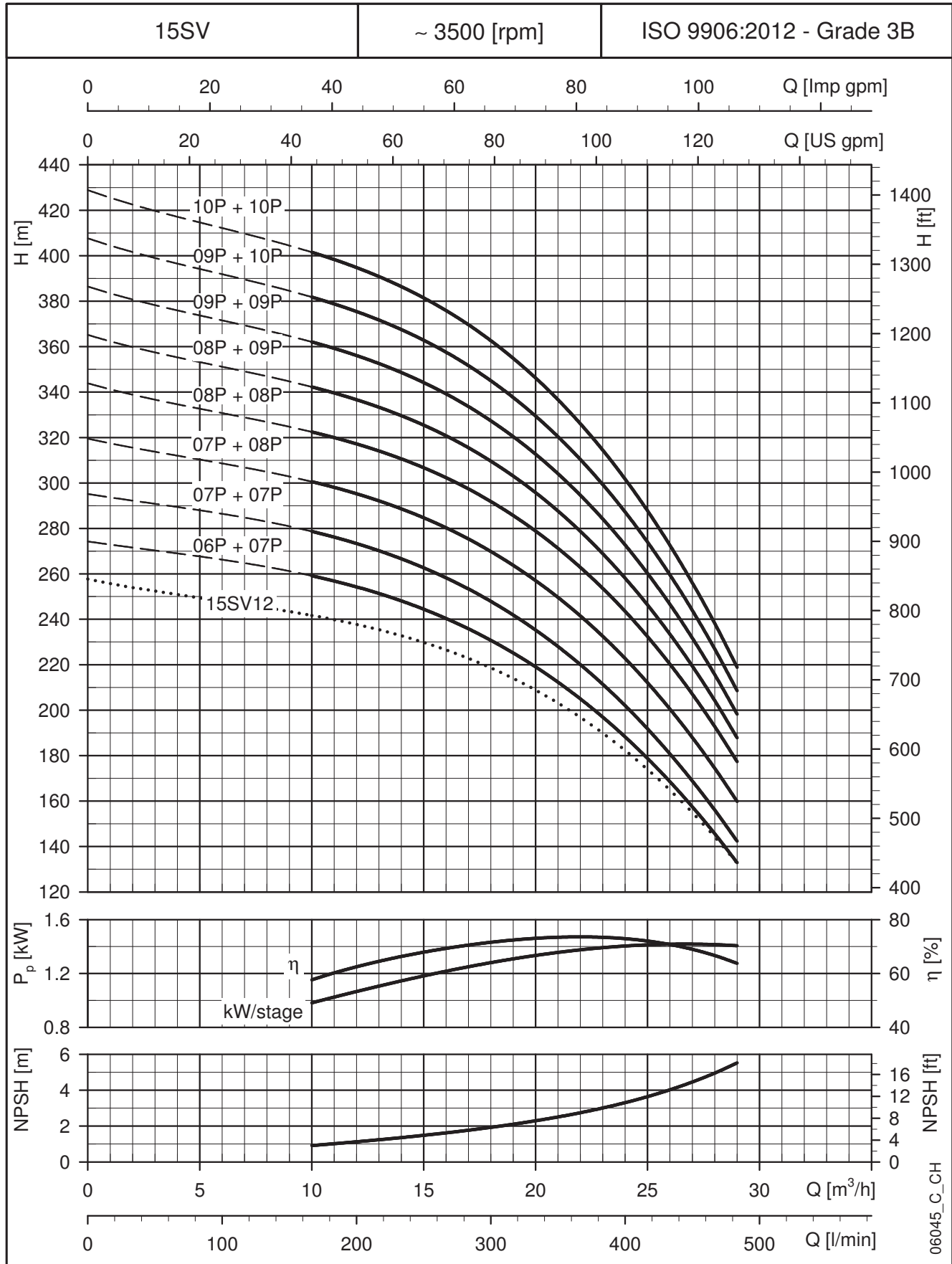

These performances are valid for liquids with density $\rho = 1.0 \text{ Kg/dm}^3$ and kinematic viscosity $\nu = 1 \text{ mm}^2/\text{sec}$.

22SV..P SERIES - HIGH PRESSURE DIMENSIONS AND WEIGHTS AT 60 Hz, 2-POLE

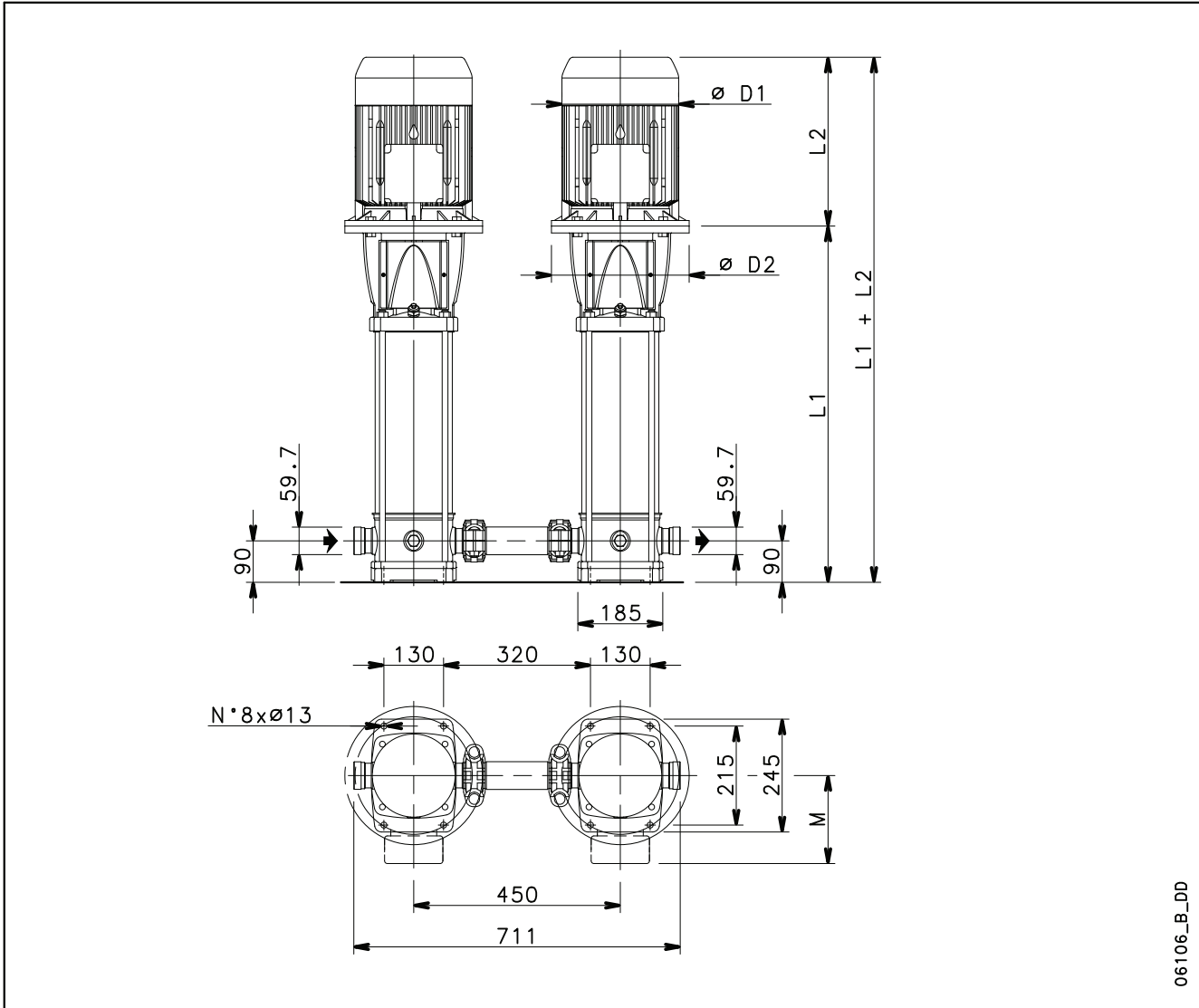

06106_B_DD

PUMP TYPE	MOTOR		DIMENSIONS (mm)					WEIGHT (Kg)	
	kW	Size	L1	L2	M	D1	D2	PUMP	ELECTRIC PUMP
22SV05P..	11	160	660	428	191	256	350	31,5	102
22SV06P..	11	160	708	428	191	256	350	33	104
22SV07P..	15	160	756	494	240	313	350	35	137
22SV08P..	15	160	804	494	240	313	350	36,5	139
22SV09P..	18,5	160	852	494	240	313	350	38	149

Dimensions and weights are related to one electric pump.

22sv-p-2p60-en_c_td

**22SV..P SERIES - HIGH PRESSURE
OPERATING CHARACTERISTICS AT 60 Hz, 2-POLE**

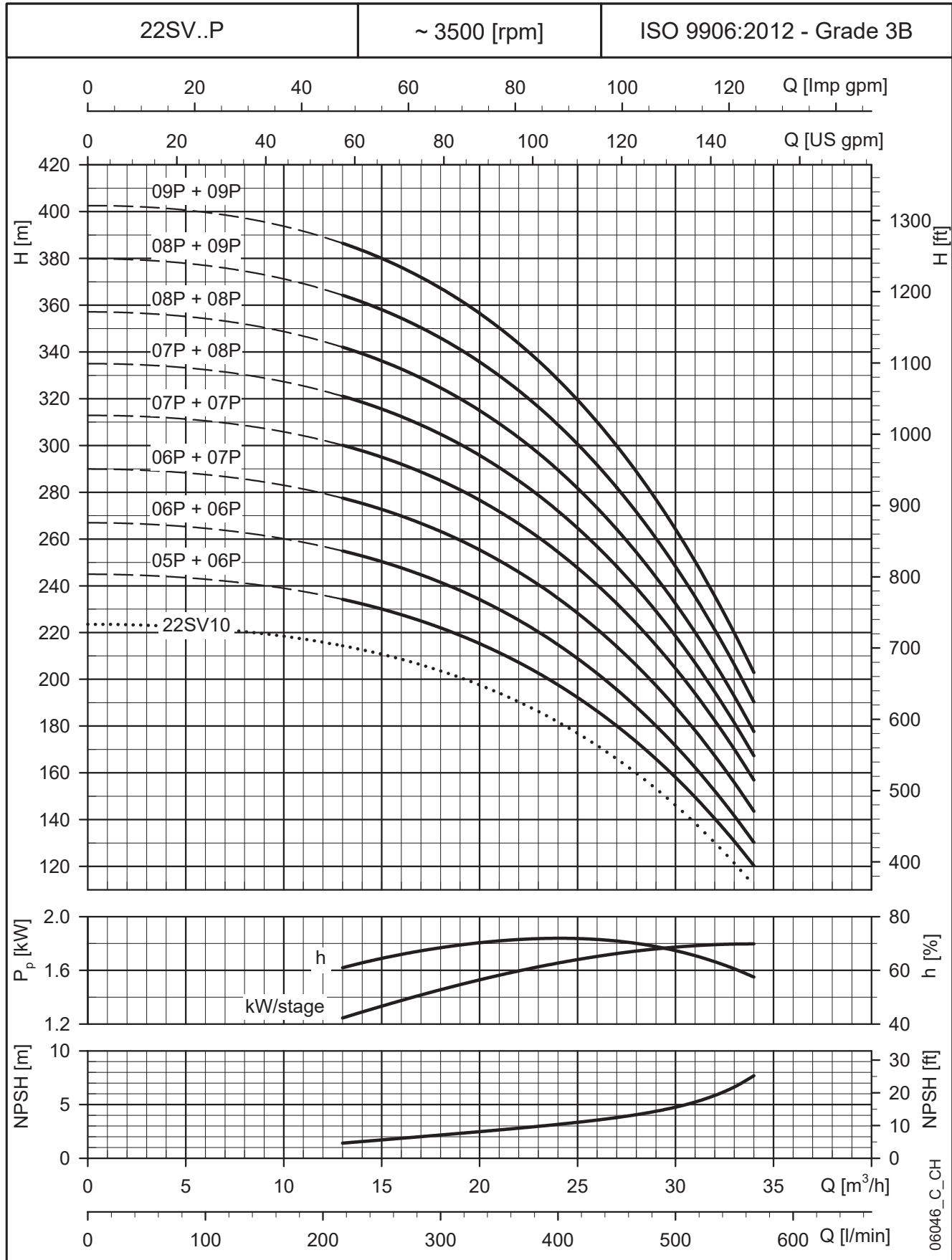

These performances are valid for liquids with density $\rho = 1.0 \text{ Kg/dm}^3$ and kinematic viscosity $\nu = 1 \text{ mm}^2/\text{sec}$.

**33SV..P SERIES - HIGH PRESSURE
DIMENSIONS AND WEIGHTS AT 60 Hz, 2-POLE**

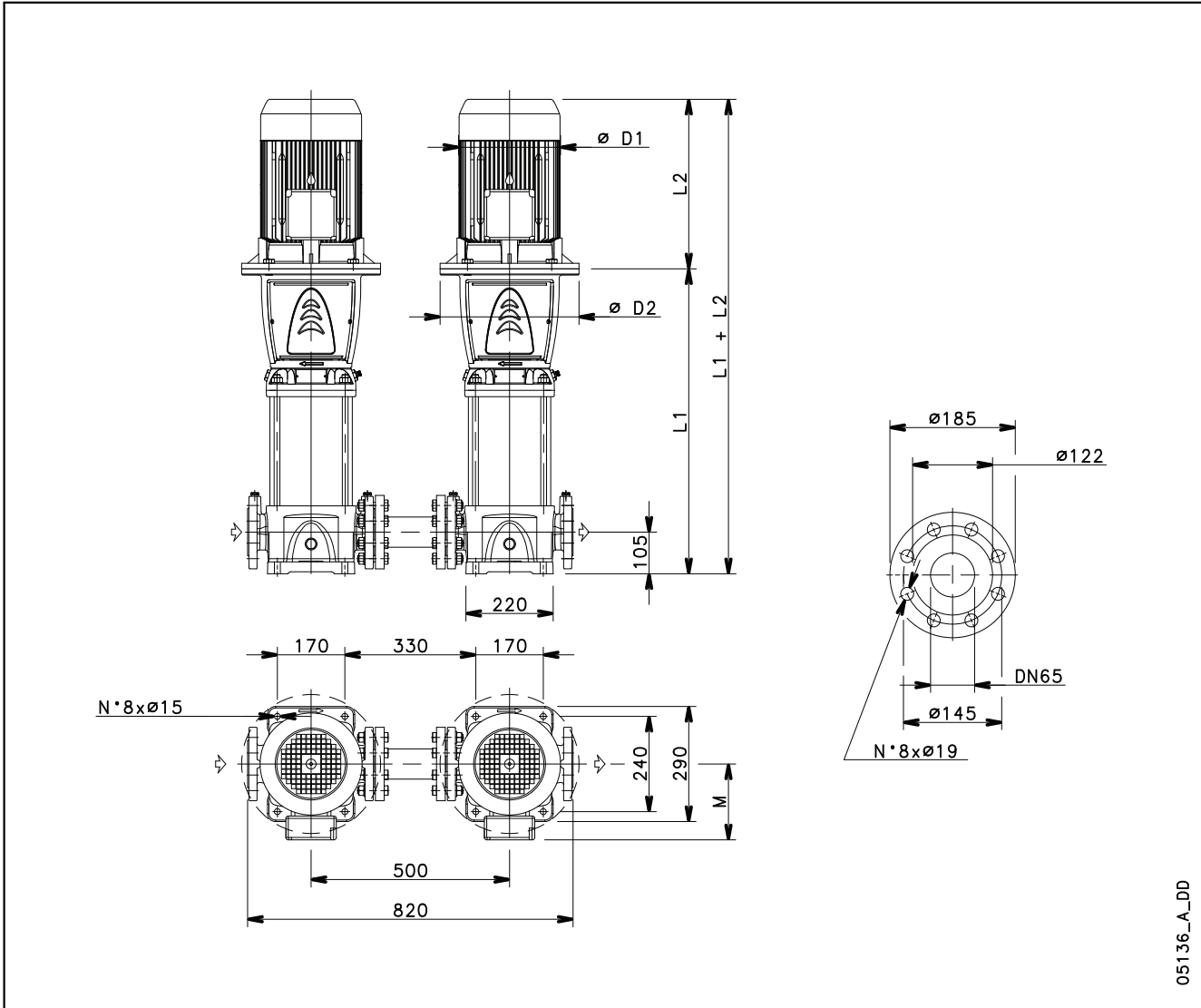

05136_A_DD

PUMP TYPE	MOTOR		DIMENSIONS (mm)					WEIGHT (Kg)	
	kW	Size	L1	L2	M	D1	D2	PUMP	ELECTRIC PUMP
33SV5/2AP..	18.5	160	844	494	240	313	350	80	191
33SV6/2AP..	22	180	919	494	240	313	350	86	208
33SV7/2AP..	30	200	994	671	285	408	400	96	304

Dimensions and weights are related to one electric pump.

33sv-p-2p60-en_c_td

**33SV..P SERIES - HIGH PRESSURE
OPERATING CHARACTERISTICS AT 60 Hz, 2-POLE**

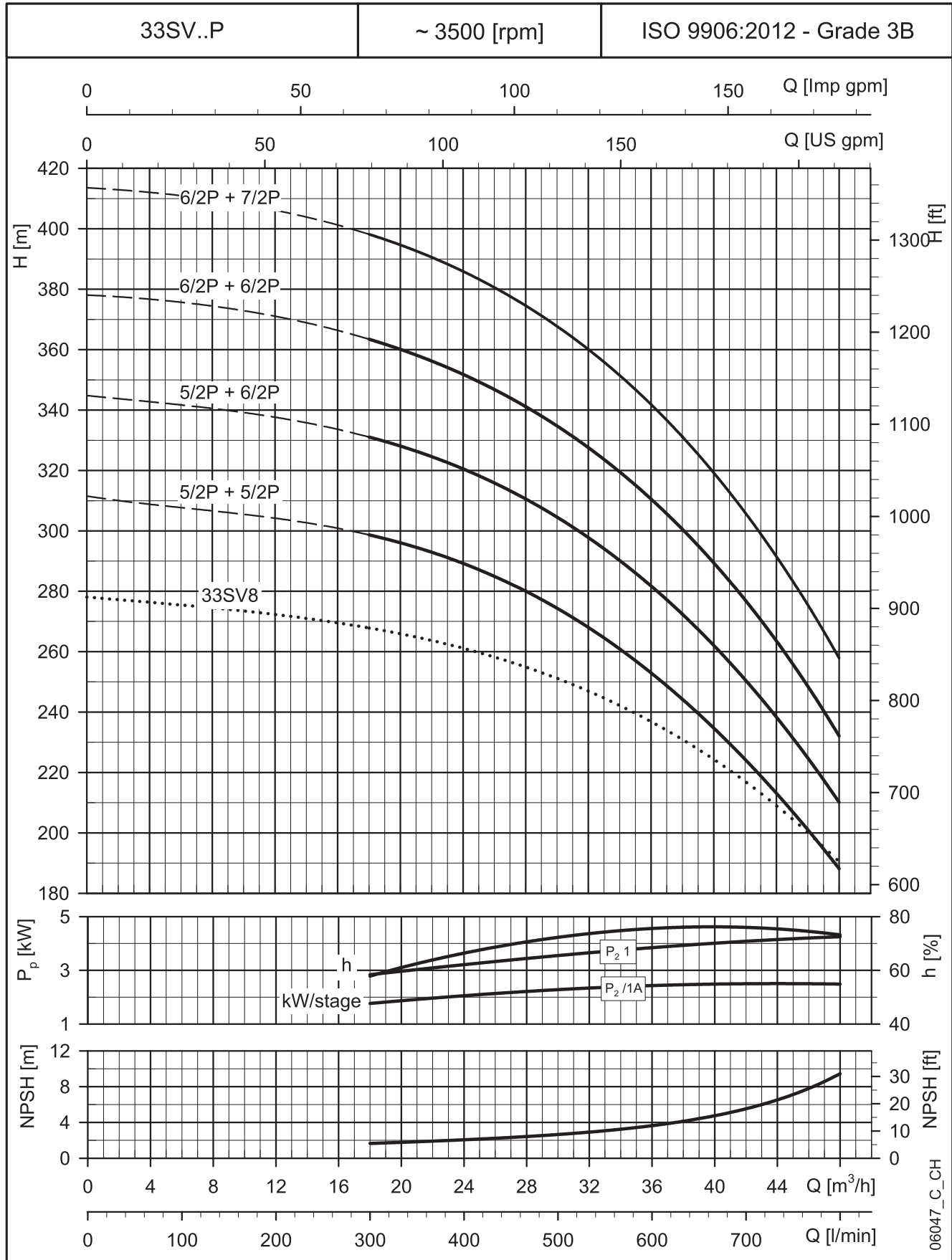

These performances are valid for liquids with density $\rho = 1.0 \text{ Kg/dm}^3$ and kinematic viscosity $\nu = 1 \text{ mm}^2/\text{sec}$.

**46SV..P SERIES - HIGH PRESSURE
DIMENSIONS AND WEIGHTS AT 60 Hz, 2-POLE**

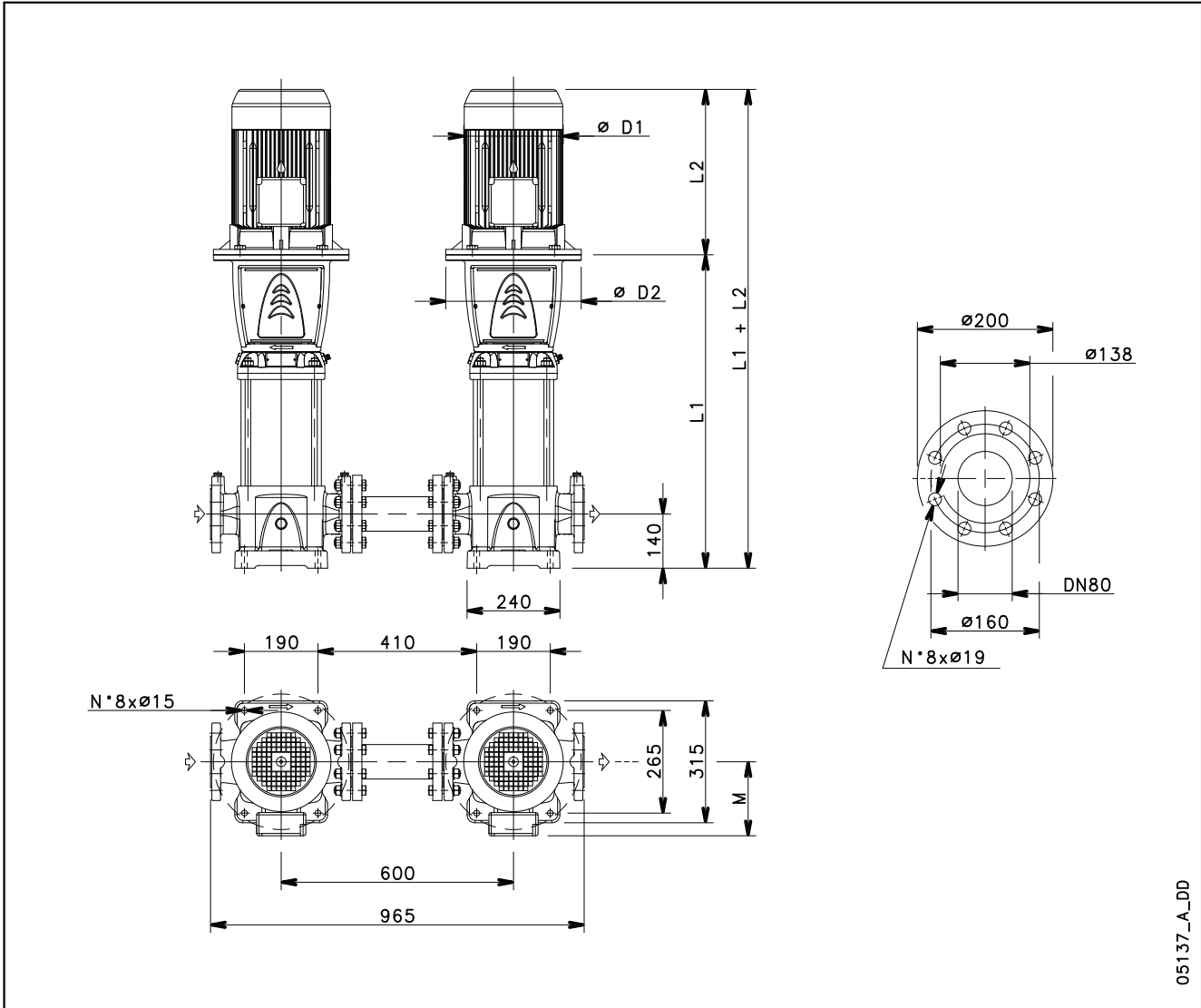

05137_A_DD

PUMP TYPE	MOTOR		DIMENSIONS (mm)					WEIGHT (Kg)	
	kW	Size	L1	L2	M	D1	D2	PUMP	ELECTRIC PUMP
46SV4P..	30	200	809	671	285	408	400	88	296
46SV5/1AP..	30	200	884	671	285	408	400	93	301
46SV6/2AP..	37	200	959	671	285	408	400	98	322

Dimensions and weights are related to one electric pump.

46sv-p-2p60-en_c_td

**46SV..P SERIES - HIGH PRESSURE
OPERATING CHARACTERISTICS AT 60 Hz, 2-POLE**

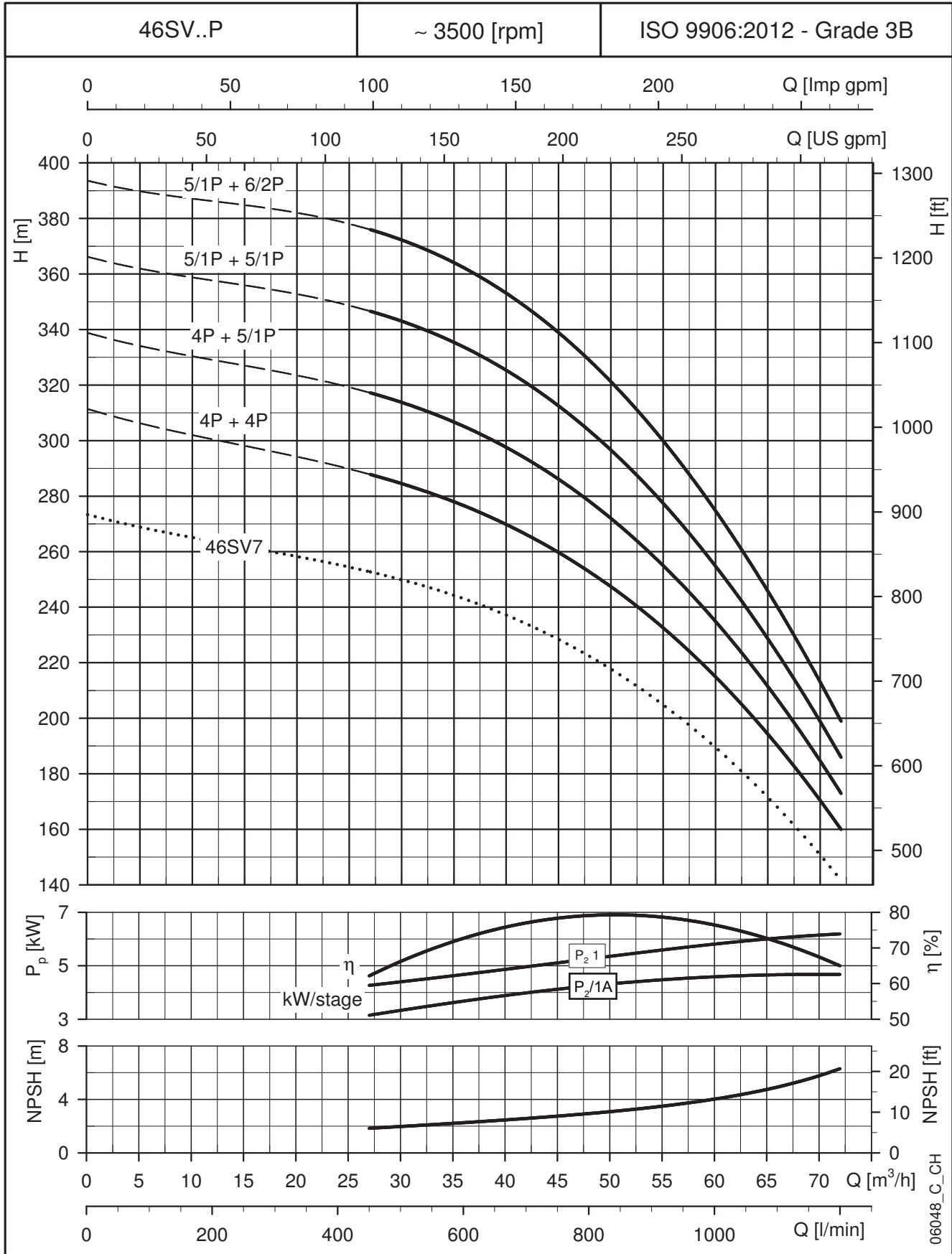

These performances are valid for liquids with density $\rho = 1.0 \text{ Kg/dm}^3$ and kinematic viscosity $\nu = 1 \text{ mm}^2/\text{sec}$.

66SV..P SERIES - HIGH PRESSURE DIMENSIONS AND WEIGHTS AT 60 Hz, 2-POLE

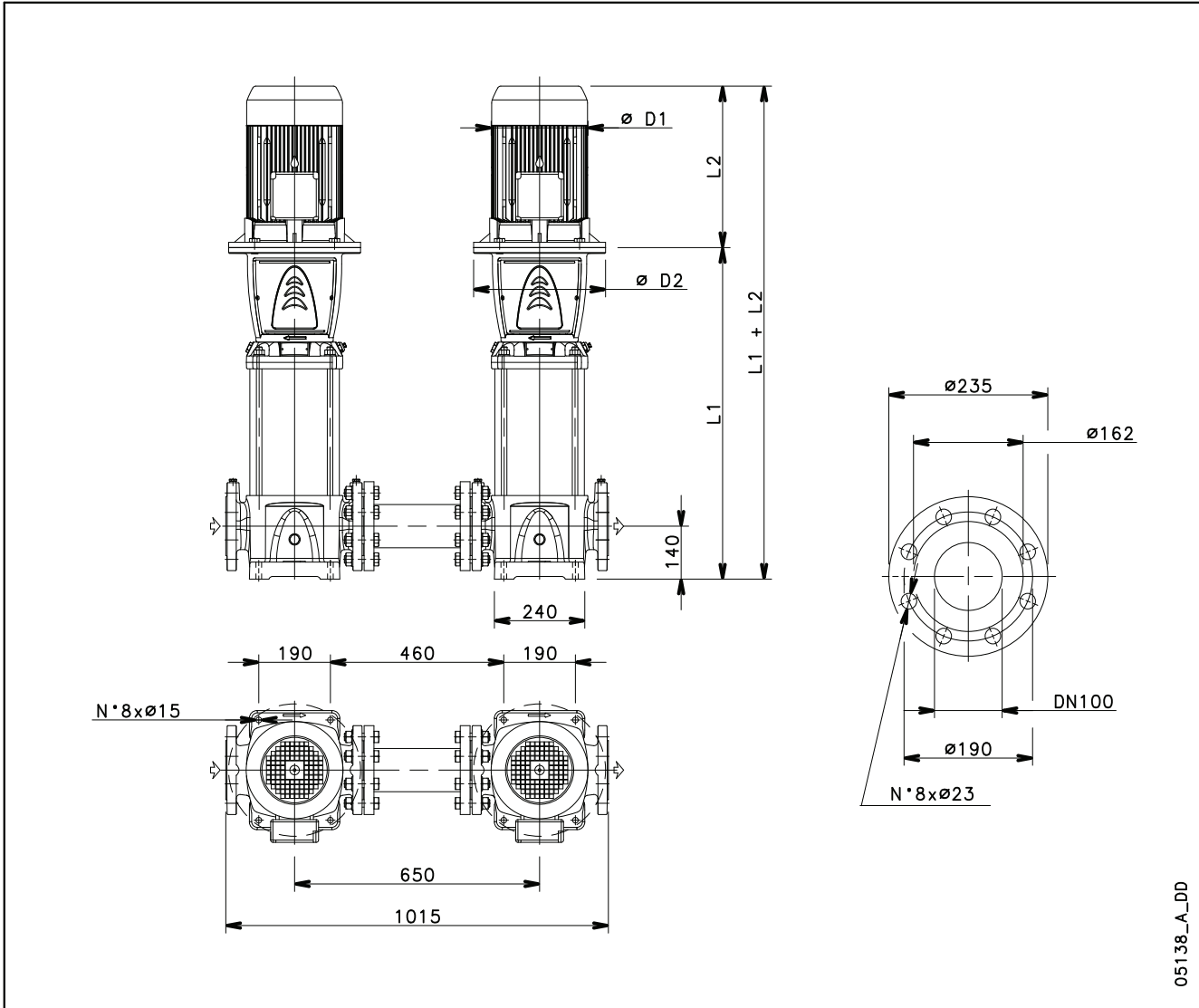

05138_A_DD

PUMP TYPE	MOTOR		DIMENSIONS (mm)					WEIGHT (Kg)	
	kW	Size	L1	L2	M	D1	D2	PUMP	ELECTRIC PUMP
66SV3/1AP..	30	200	789	671	285	408	400	97	305
66SV4/2AP..	37	200	879	671	285	408	400	104	328
66SV4P..	37	200	879	671	285	408	400	106	330
66SV5/2AP..	45	250	969	701	309	460	450	116	408
66SV5P..	45	250	969	701	309	460	450	116	408

Dimensions and weights are related to one electric pump.

66sv-p-2p60-en_c_td

**66SV..P SERIES - HIGH PRESSURE
OPERATING CHARACTERISTICS AT 60 Hz, 2-POLE**

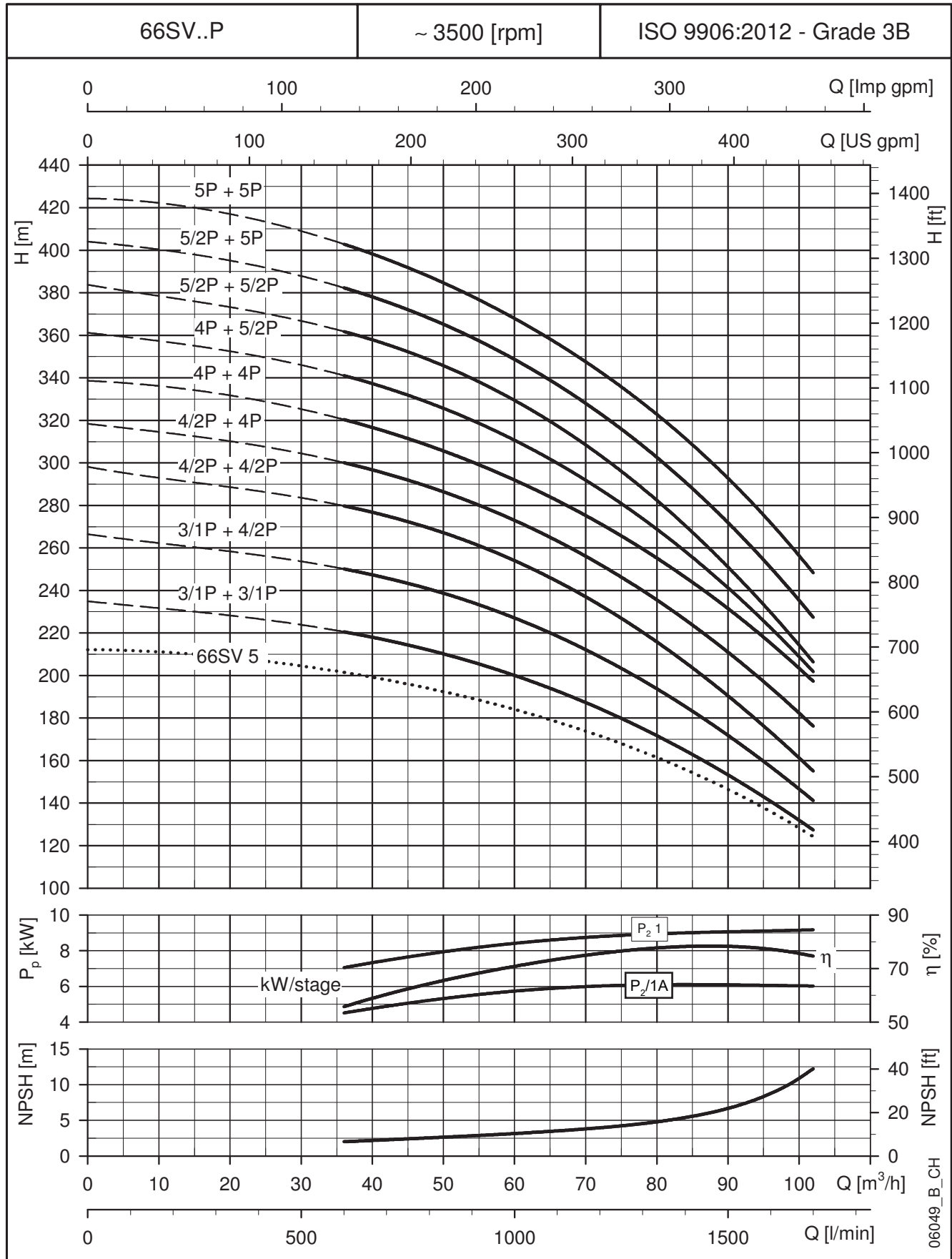

These performances are valid for liquids with density $\rho = 1.0 \text{ Kg/dm}^3$ and kinematic viscosity $\nu = 1 \text{ mm}^2/\text{sec}$.

**92SV..P SERIES - HIGH PRESSURE
DIMENSIONS AND WEIGHTS AT 60 Hz, 2-POLE**

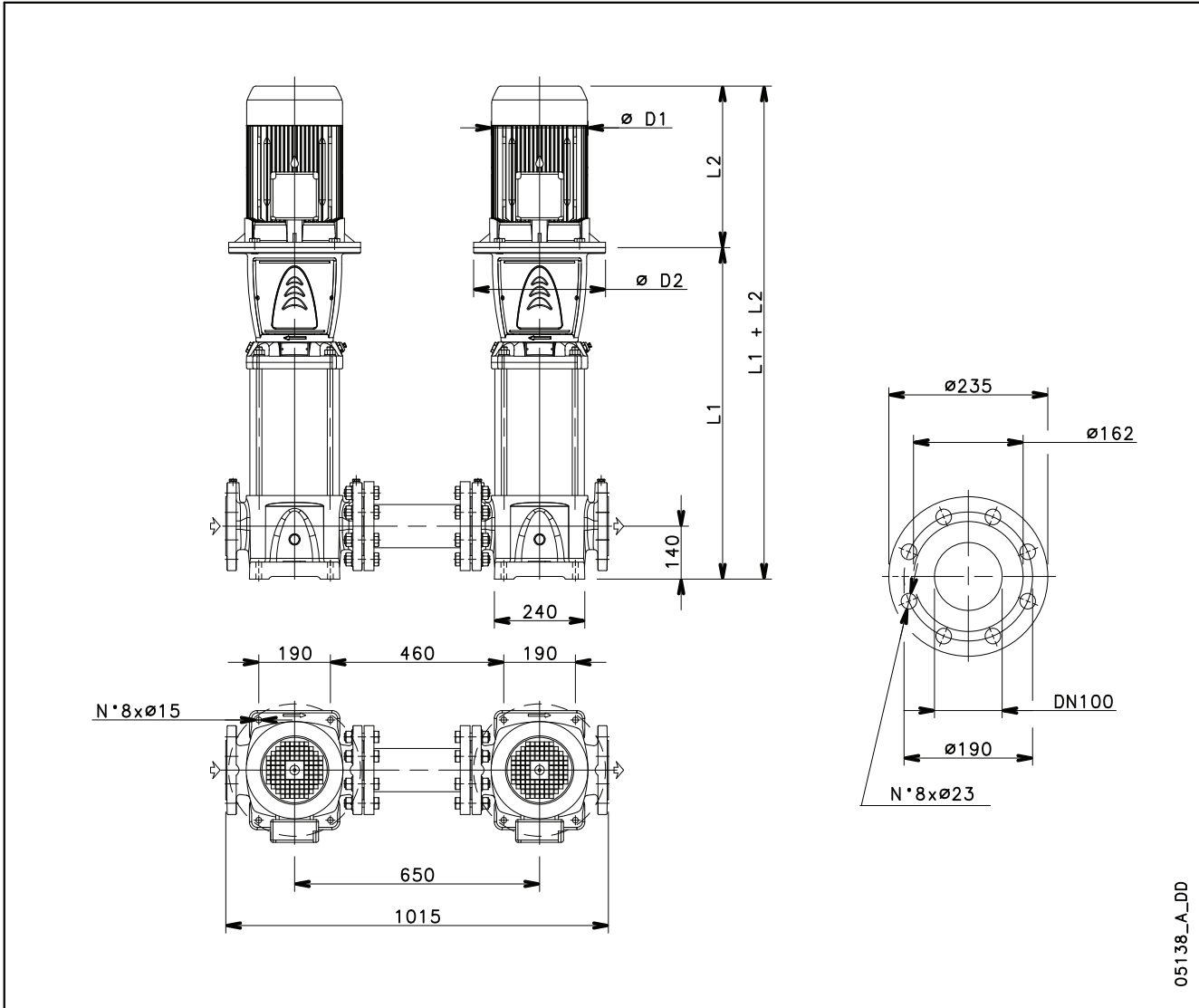

05138_A_DD

PUMP TYPE	MOTOR		DIMENSIONS (mm)					WEIGHT (Kg)	
	kW	Size	L1	L2	M	D1	D2	PUMP	ELECTRIC PUMP
92SV2P..	30	200	699	671	285	408	400	91	299
92SV3/2AP..	37	200	789	671	285	408	400	97	321
92SV3/1AP..	37	200	789	671	285	408	400	97	321
92SV3P..	45	250	789	701	309	460	450	100	392
92SV4/2AP..	45	250	879	701	309	460	450	103	395

Dimensions and weights are related to one electric pump.

92sv-p-2p60-en_c_td

**92SV..P SERIES - HIGH PRESSURE
OPERATING CHARACTERISTICS AT 60 Hz, 2-POLE**

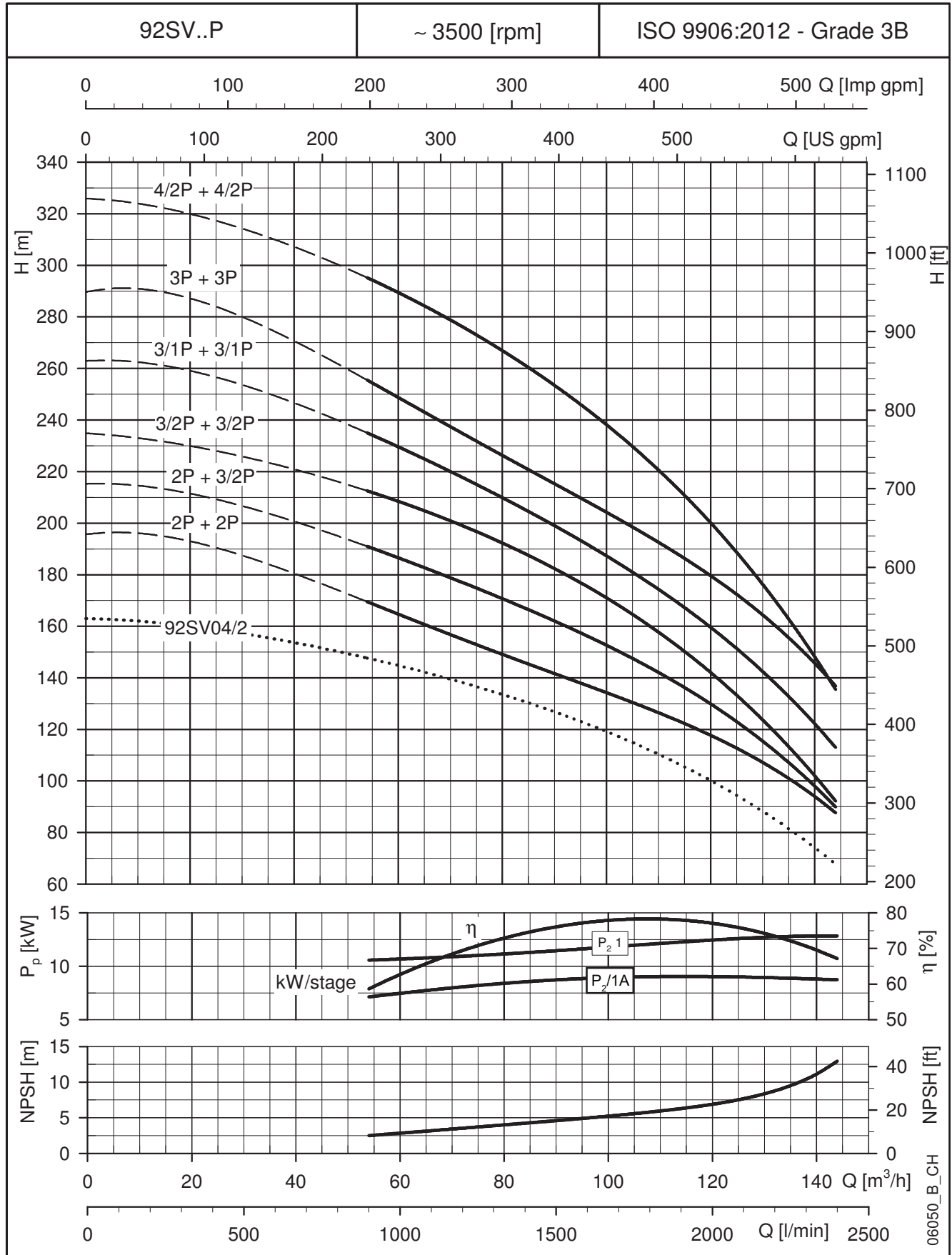

These performances are valid for liquids with density $\rho = 1.0 \text{ Kg/dm}^3$ and kinematic viscosity $\nu = 1 \text{ mm}^2/\text{sec}$.

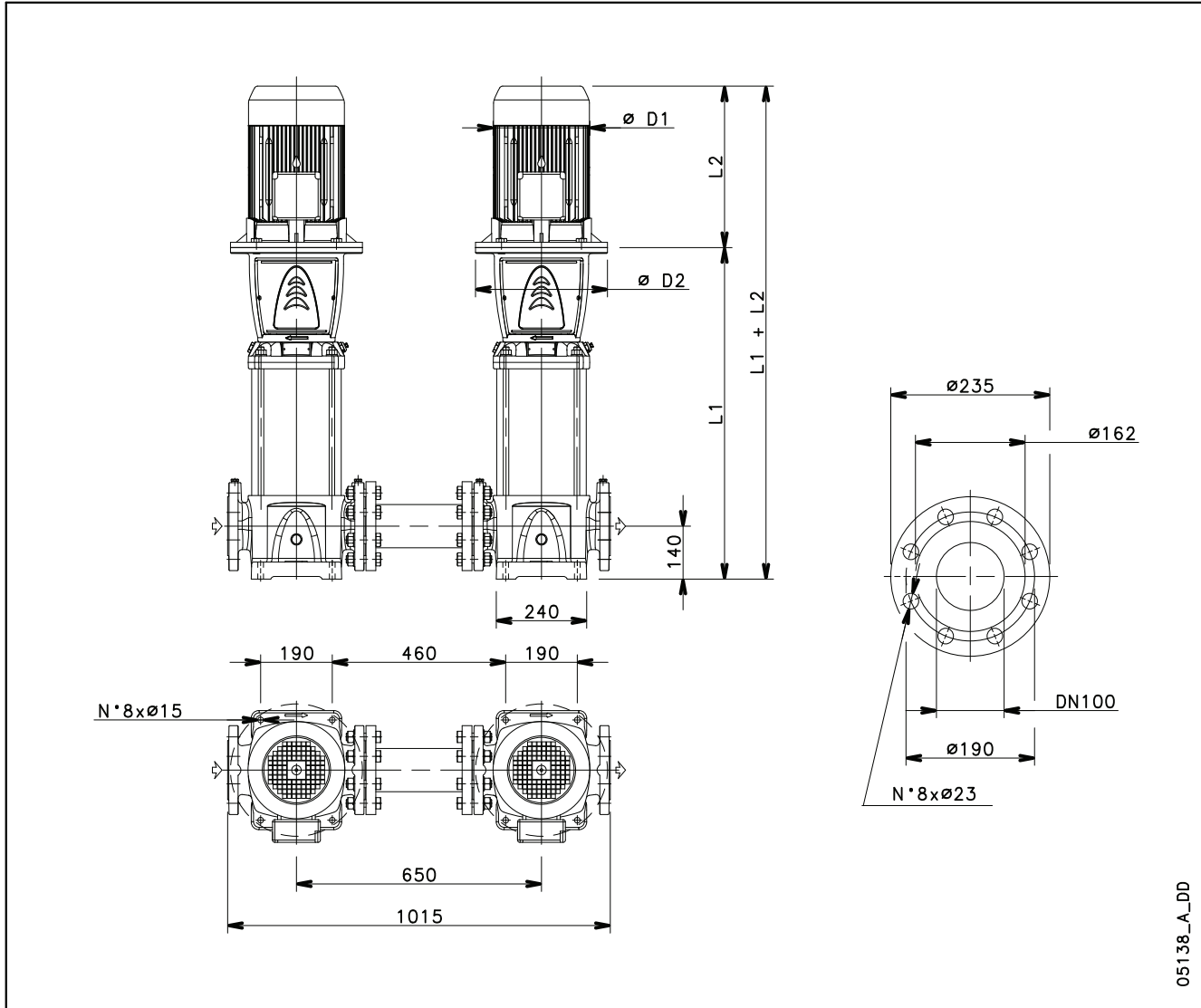
**125SV..P SERIES - HIGH PRESSURE
DIMENSIONS AND WEIGHTS AT 60 Hz, 2-POLE**

05138_A_DD

PUMP TYPE	MOTOR		DIMENSIONS (mm)					WEIGHT (Kg)	
	kW	Size	L1	L2	M	D1	D2	PUMP	ELECTRIC PUMP
125SV3/3BP..	30	200	1028	671	285	408	400	155	363
125SV3P..	37	200	1028	671	285	408	400	156	380
125SV4/4AP..	45	225	1178	701	309	460	450	172	464
125SV5/5AP..	55	250	1358	767	362	502	550	198	640

Dimensions and weights are related to one electric pump.

125sv-p-2p60-en_c_td

125SV..P SERIES - HIGH PRESSURE OPERATING CHARACTERISTICS AT 60 Hz, 2-POLE

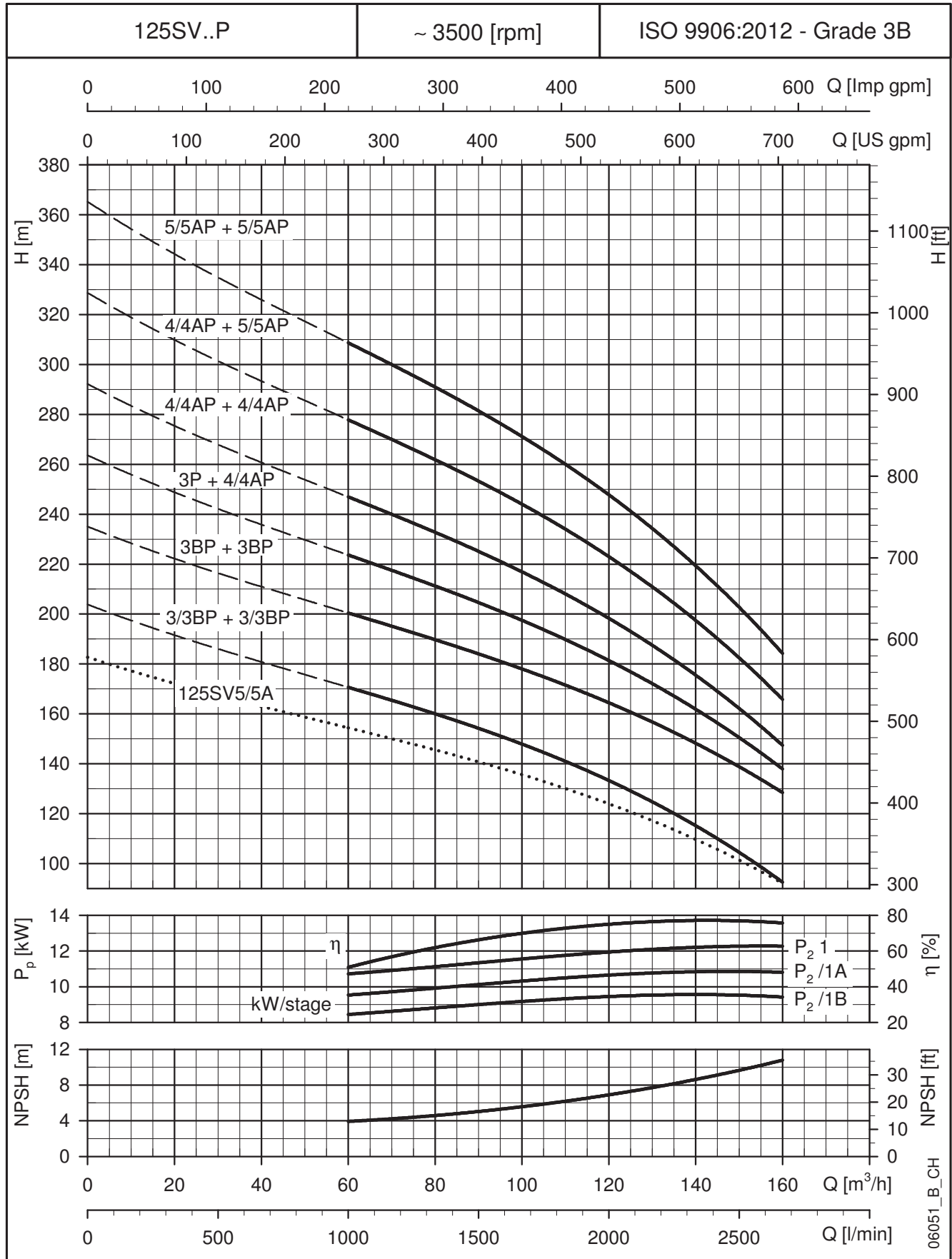

These performances are valid for liquids with density $\rho = 1.0 \text{ Kg/dm}^3$ and kinematic viscosity $\nu = 1 \text{ mm}^2/\text{sec}$.

LOW NPSH (50/60 Hz)

e-SV SERIES - LOW NPSH 50/60 Hz

Background and context

In industrial applications, often pumps are exposed to heavy duty installations and conditions, such as pumping high temperature liquids (boiler-feed), poor inlet pressure conditions or high flow rate applications. In these cases, constant and durable pump operation is often compromised by cavitation. Therefore Lowara has developed e-SV Low NPSH versions: a pump which delivers a definitive and valuable solution to solve cavitation issues in installation.

Benefits of e-SV Low NPSH

Consistent operation: the special design of the first initial stage together with a specific impeller design allows e-SV Low NPSH versions to improve its suction capacity. Even in critical suction conditions, the pump is able to deliver consistent and constant operation on the whole application range.

Long lasting performances: e-SV Low NPSH design ensures consistency in its operation. The specific design of e-SV Low NPSH versions saves the pump of the cavitation: the components in the pump are not submitted to stress, decreasing the need of repetitive maintenance and reducing the life cycle cost of the pump.

Easy installation: e-SV Low NPSH versions is easy to install and allows saving space. Where traditional pumps will need to have a tank to facilitate the suction conditions, the specific design of e-SV Low NPSH version allows installing the pumps without any additional accessories on the suction side. A compact design where reduced spaces are favored.

Code identification

e-SV Low NPSH design is identified with a "L" in the product codification of the whole e-SV range.

Example: 3SV13FL015T

L = Low NPSH version.



Special features / product benefits

- **Specific first stage design** to maximize suction conditions.
- **Standard mechanical seal** (EN12756) fitted on all models. **Easy to replace without removing the motor** from 5,5 kW.
- **Hard material intermediate bush bearing** (Tungsten Carbide) to improve lifetime and capacity of working in extreme conditions, available on all sizes.
- **Balanced impeller design** to reduce axial thrust for longer standard motor bearing life.
- **Wide range of sizes to cover all requested duty points:** from 1SV to 66SV.

Special configurations

- e-SV Low NPSH offers a wide range of configurations:
- Materials used: see the Materials section.
 - Options for mechanical seals and gaskets: see the mechanical seals and gaskets section.
 - Options for motors and configuration: see the motors section.
 - HYDROVAR™ system included

**e-SV SERIES - LOW NPSH
50/60 Hz**

Technical characteristics - Design

- 1: Specific initial impeller design to maximize suction abilities.
- 2: Specific initial stage design to enhance suction capabilities of the pump.

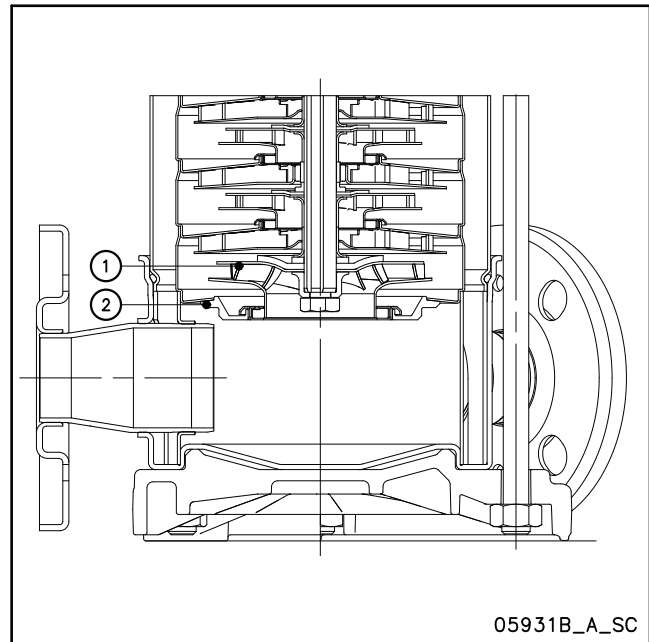

e-SV SERIES - LOW NPSH TECHNICAL CHARACTERISTICS

L VERSIONS - 50 Hz	1SV	3SV	5SV	10SV	15SV	22SV	33SV	46SV	66SV
Max efficiency flow (m ³ /h)	1.7	3.3	5.9	10.5	18	20.5	33	44	75
Flow range (m ³ /h)	0,7÷2,4	1,2÷4,4	2,4÷8,5	5÷14	8÷24	11÷29	15÷40	22÷60	30÷85
Maximum head (m)	230	250	250	250	250	250	310	320	240
Motor power (kW)	0,37÷2,2	0,37÷3	0,75÷5,5	1,5÷11	3÷15	3÷18,5	5,5÷37	7,5÷45	11÷45
Max η (%) of pump	50	62	67	71	70	71	77	76	78
Standard temperature of pumped liquid (°C)	-30 +120								
Min/max NPSHr value (m)	0,4÷0,6	0,5÷0,9	0,4÷1,5	0,5÷1,3	1÷2	1,1÷2,6	1÷2,4	1,8÷2,5	1,5÷3,3
Material execution	No variation according to e-SV versions: F (AISI 304), G (AISI 304/Cast Iron), N (AISI 316)								
Mechanical seal configuration	No variation according to e-SV series								
Flange configuration*	Round flange (F, G, N versions)								

svL-50-en_c_tg

L VERSIONS - 60 Hz	1SV	3SV	5SV	10SV	15SV	22SV	33SV	46SV	66SV
Max efficiency flow (m ³ /h)	2.2	3.9	7	12.8	22	25	39	53	85
Flow range (m ³ /h)	0,8÷2,8	1,4÷5,2	3÷10	6÷17	10÷29	13÷34	18÷48	27÷72	36÷102
Maximum head (m)	250	250	250	250	250	220	280	260	200
Motor power (kW)	0,37÷3	0,55÷4	1,1÷7,5	3÷11	4÷18,5	5,5÷22	7,5÷37	15÷45	18,5÷45
Max η (%) of pump	54	63	70	71	70	73	77	76	78
Standard temperature of pumped liquid (°C)	-30 +120								
Min/max NPSHr value (m)	0,5÷0,7	0,8÷1,3	0,9÷2,1	0,8÷1,8	1,3÷2,9	1,6÷3,4	1,3÷3,2	2,2÷3,3	3÷4,3
Material execution	No variation according to e-SV versions: F (AISI 304), G (AISI 304/Cast Iron), N (AISI 316)								
Mechanical seal configuration	No variation according to e-SV series								
Flange configuration*	Round flange (F, G, N versions)								

svL-60-en_c_tg

* Other flange configuration available for 1-22SV on request.

**e-SV SERIES - LOW NPSH
IDENTIFICATION OF GRAPH**

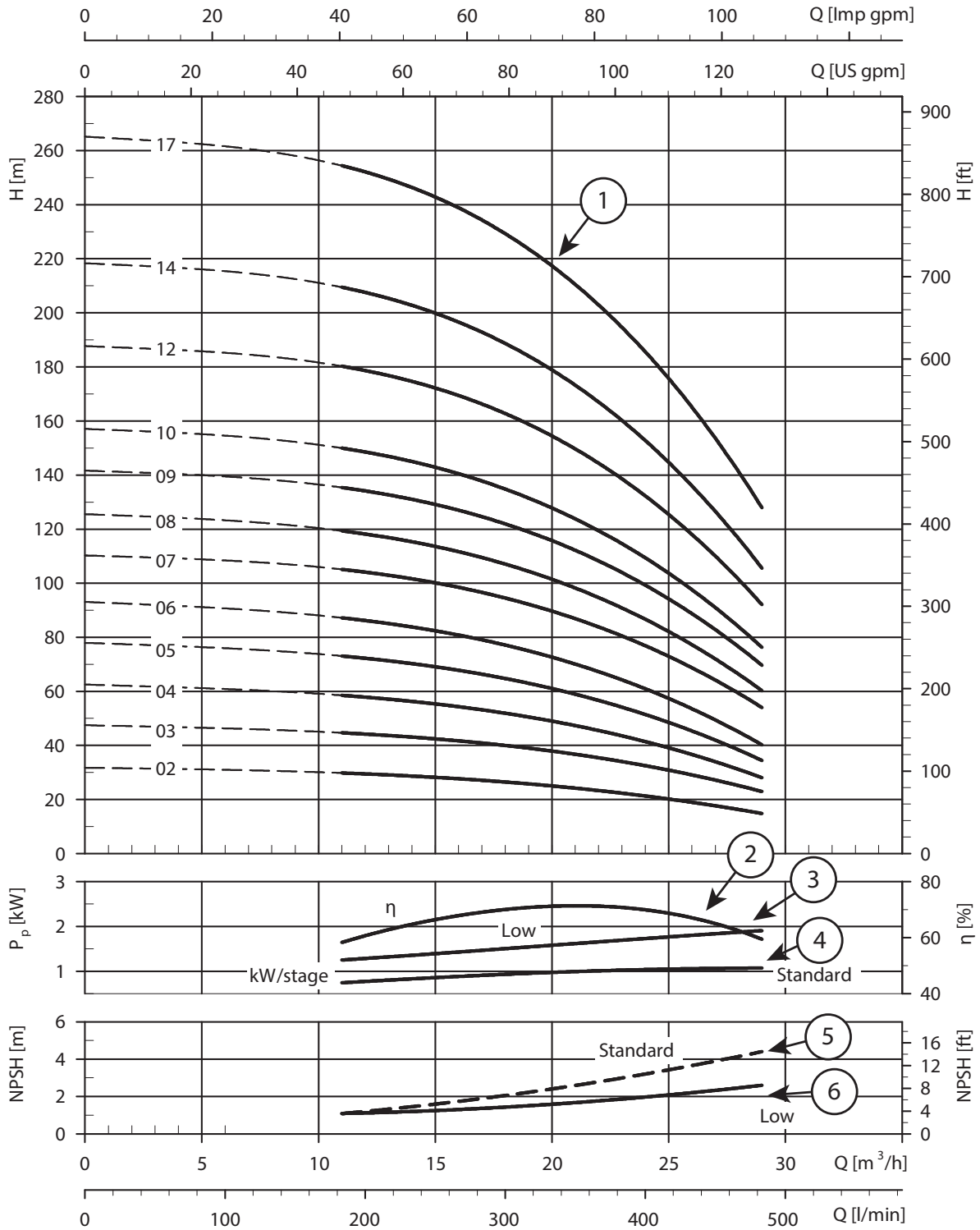

REF	DESCRIPTION
①	Operating characteristics
②	Pump Efficiency
③	Power absorbed by the LOW NPSH stage (PLow)

REF	DESCRIPTION
④	Power absorbed by the standard stage (PStandard)
⑤	NPSH curve of standard pump
⑥	NPSH curve of Low NPSH pump

The total absorbed power is calculated by the following formula:
 $P_{pump\ total} = P_{Low} + P_{standard} \times (n. \text{ of stage} - 1)$

1SV..L SERIES - LOW NPSH - 3 TO 15 STAGES DIMENSIONS AND WEIGHTS AT 50 Hz, 2-POLE

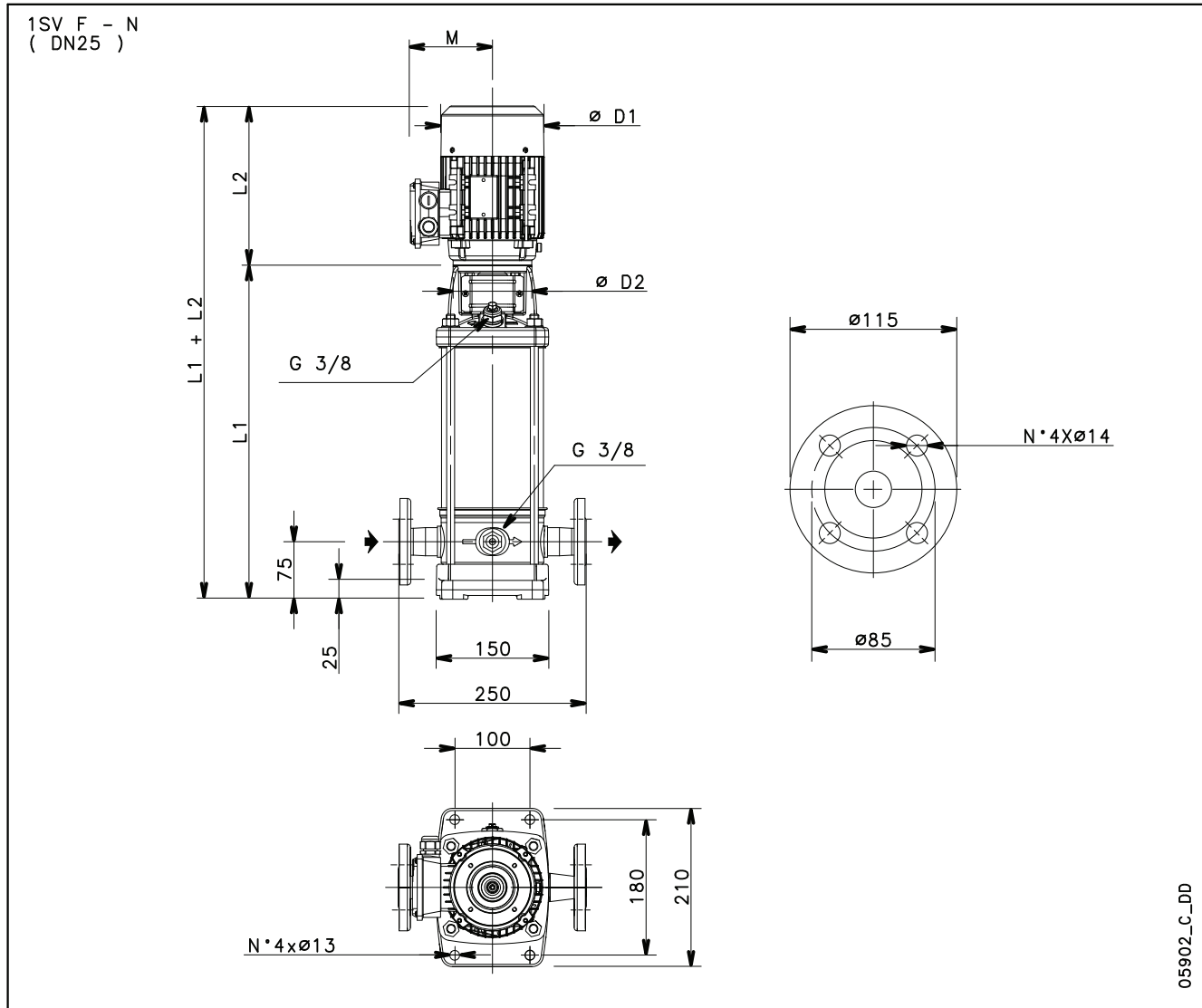

05902_C_DD

PUMP TYPE	MOTOR		DIMENSIONS (mm)								PN bar	MEI ≥ (1)	PESO kg	
	kW	SIZE	L1	L2		M		D1		D2			PUMP	ELECTRIC PUMP
1SV03..L..	0,37	71	278	209	209	111	111	120	120	105	25	0,70	8,6	13,4
1SV04..L..	0,37	71	298	209	209	111	111	120	120	105	25	0,70	9	13,8
1SV05..L..	0,37	71	318	209	209	111	111	120	120	105	25	0,70	9,4	14,2
1SV06..L..	0,37	71	338	209	209	111	111	120	120	105	25	0,70	9,8	14,6
1SV07..L..	0,37	71	358	209	209	111	111	120	120	105	25	0,70	10,2	14,9
1SV08..L..	0,55	71	378	231	231	121	121	140	140	105	25	0,70	10,5	15,2
1SV09..L..	0,55	71	398	231	231	121	121	140	140	105	25	0,70	10,9	15,6
1SV10..L..	0,55	71	418	231	231	121	121	140	140	105	25	0,70	11,3	16
1SV11..L..	0,55	71	438	231	231	121	121	140	140	105	25	0,70	11,7	16,4
1SV12..L./D	0,75	80	468	226	263	121	129	140	155	120	25	0,70	12,7	22,3
1SV13..L./D	0,75	80	488	226	263	121	129	140	155	120	25	0,70	13,1	22,7
1SV15..L./D	0,75	80	528	226	263	121	129	140	155	120	25	0,70	13,9	23,5

(1) Value referred to the F, N versions.

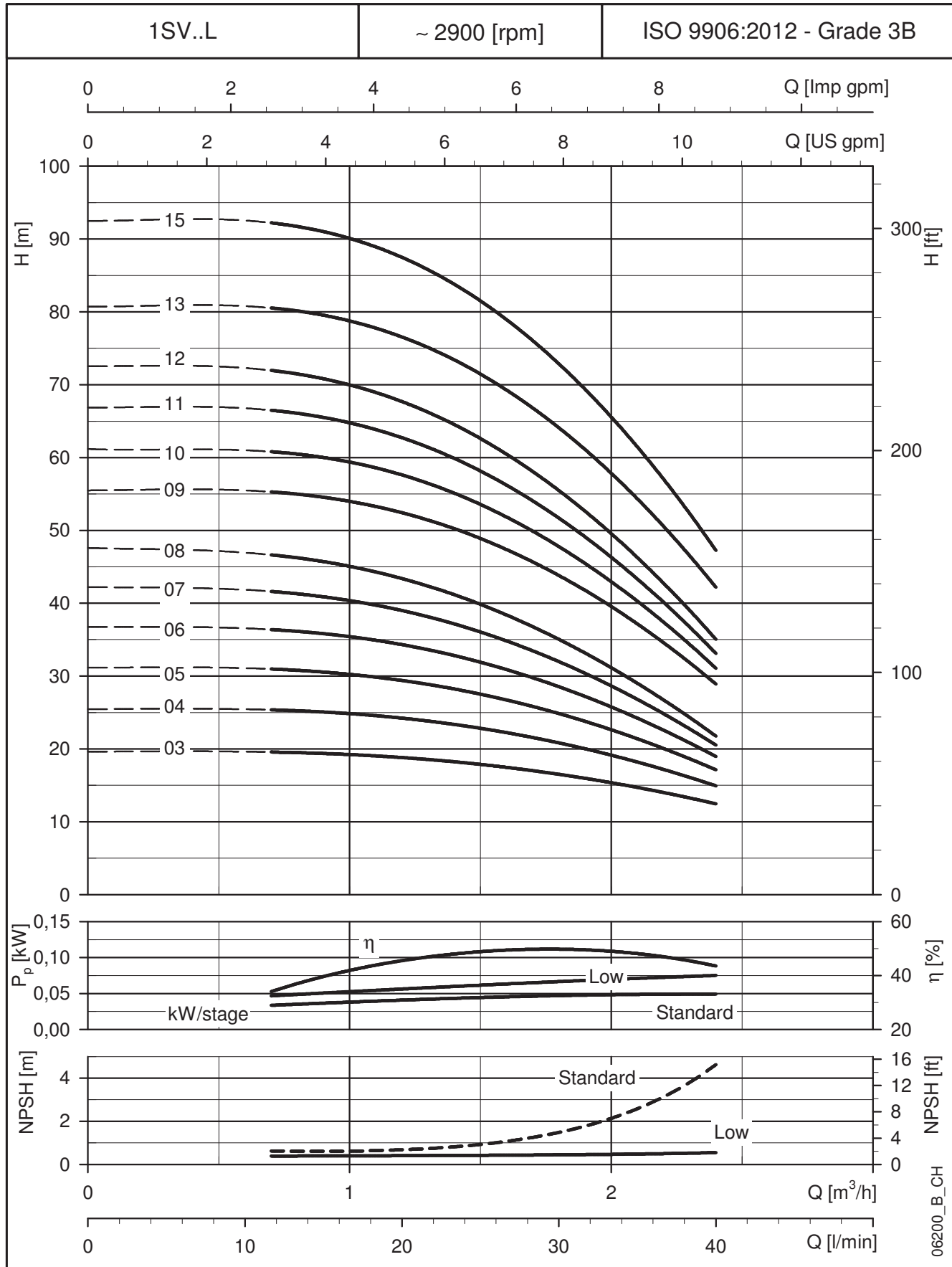
**1SV..L SERIES - LOW NPSH - 3 TO 15 STAGES
OPERATING CHARACTERISTICS AT 50 Hz, 2-POLE**

 These performances are valid for liquids with density $\rho = 1.0 \text{ Kg/dm}^3$ and kinematic viscosity $\nu = 1 \text{ mm}^2/\text{sec}$.

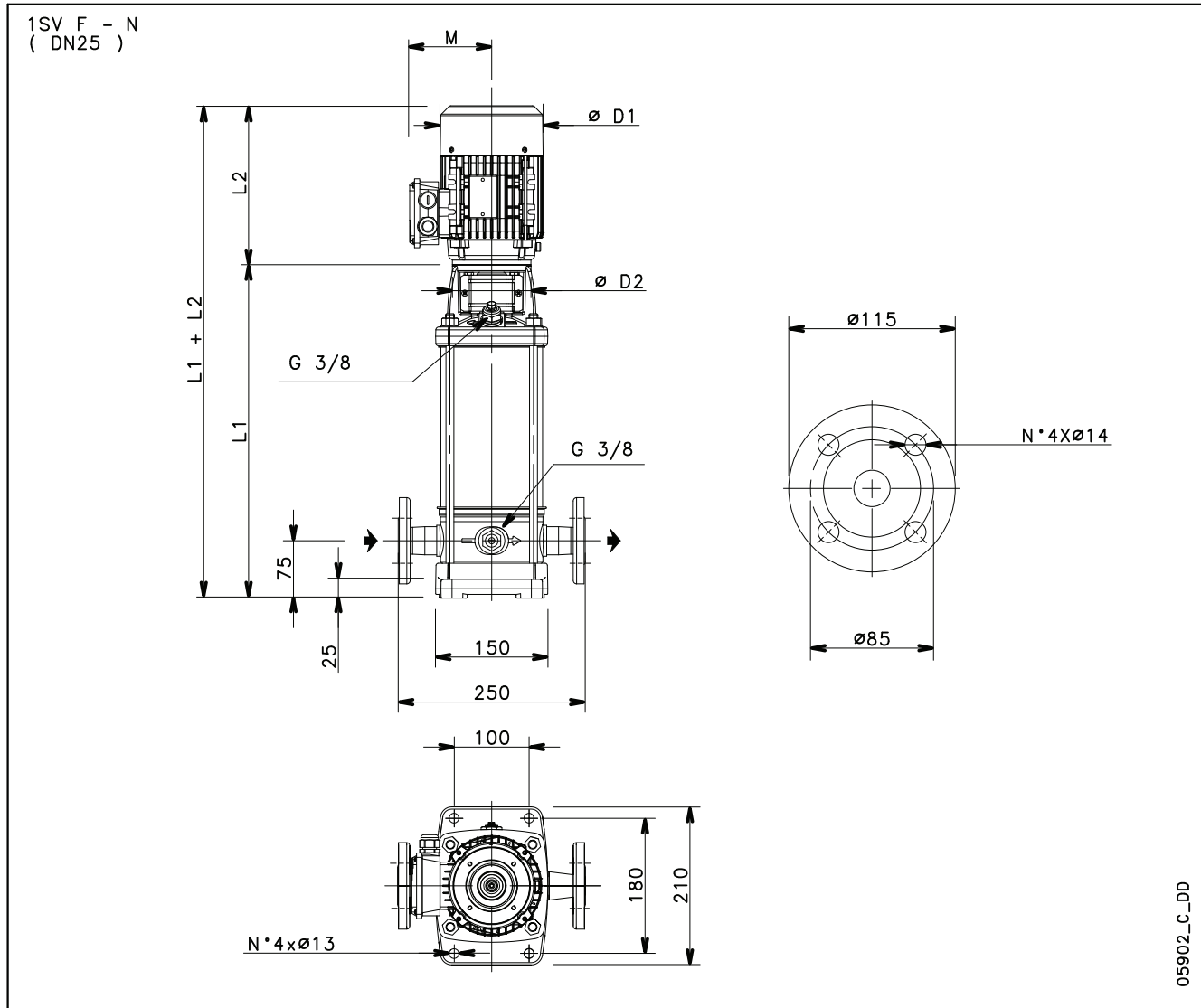
1SV..L SERIES - LOW NPSH - 17 TO 37 STAGES DIMENSIONS AND WEIGHTS AT 50 Hz, 2-POLE



PUMP TYPE	MOTOR		DIMENSIONS (mm)								PN bar	MEI ≥ (1)	WEIGHT kg	
	kW	SIZE	L1	L2		M		D1		D2			PUMP	ELECTRIC PUMP
1SV17..L./D	1,1	80	568	263	263	137	129	155	155	120	25	0,70	14,7	26,6
1SV19..L./D	1,1	80	608	263	263	137	129	155	155	120	25	0,70	15,5	27,4
1SV22..L./D	1,1	80	668	263	263	137	129	155	155	120	25	0,70	16,7	28,6
1SV25..L./D	1,5	90	738	263	263	137	129	155	155	140	25	0,70	18,7	31,7
1SV27..L./D	1,5	90	778	263	263	137	129	155	155	140	25	0,70	19,5	32,5
1SV30..L./D	1,5	90	838	263	263	137	129	155	155	140	25	0,70	20,7	33,7
1SV32..L..	2,2	90	878	298	298	151	134	174	174	140	25	0,70	21,5	37,8
1SV34..L..	2,2	90	918	298	298	151	134	174	174	140	25	0,70	22,3	38,6
1SV37..L..	2,2	90	978	298	298	151	134	174	174	140	25	0,70	23,5	39,8

(1) Value referred to the F, N versions.

1SV..L SERIES - LOW NPSH - 17 TO 37 STAGES
OPERATING CHARACTERISTICS AT 50 Hz, 2-POLE

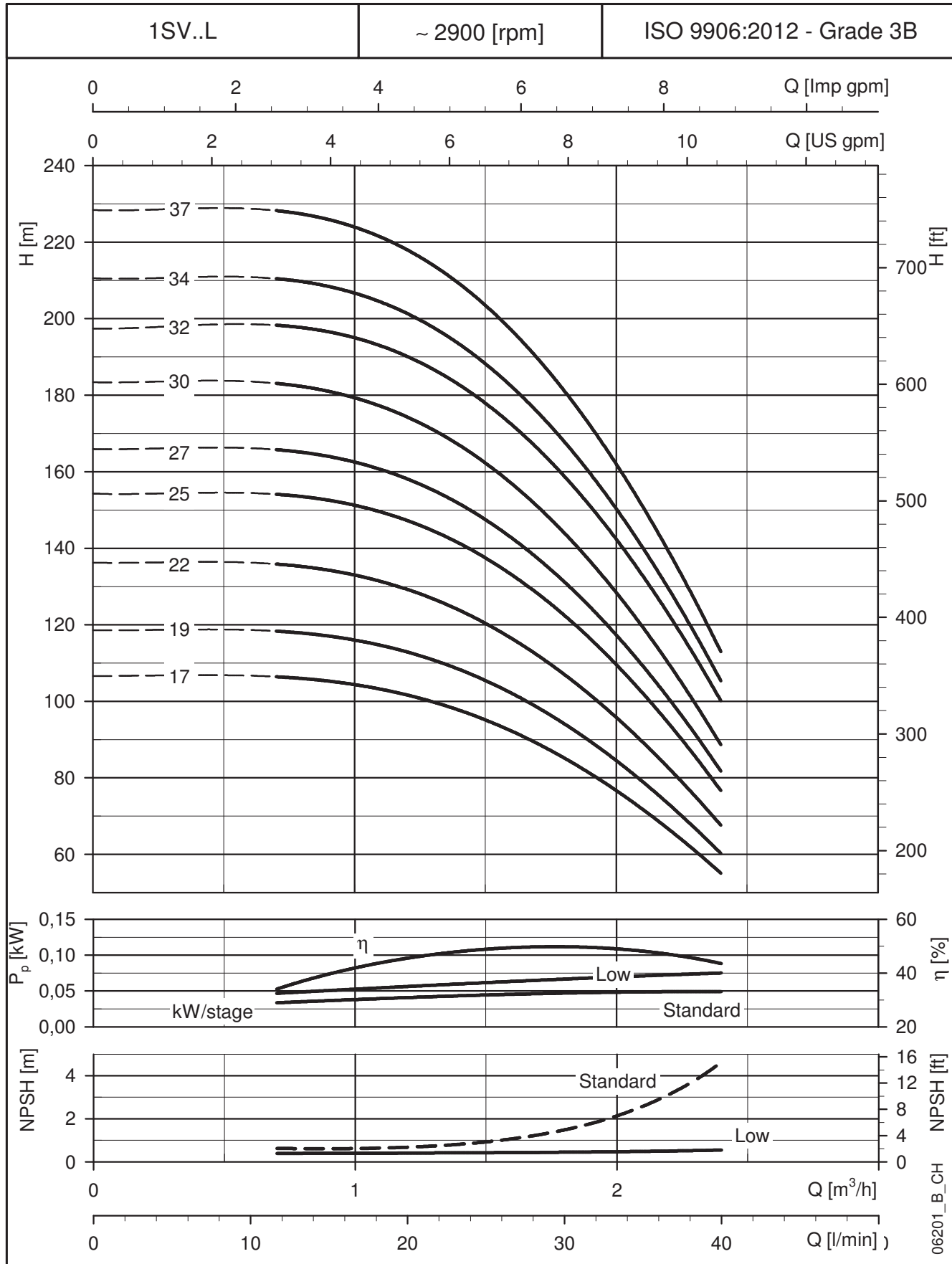

These performances are valid for liquids with density $\rho = 1.0 \text{ Kg/dm}^3$ and kinematic viscosity $\nu = 1 \text{ mm}^2/\text{sec}$.

3SV..L SERIES - LOW NPSH DIMENSIONS AND WEIGHTS AT 50 Hz, 2-POLE

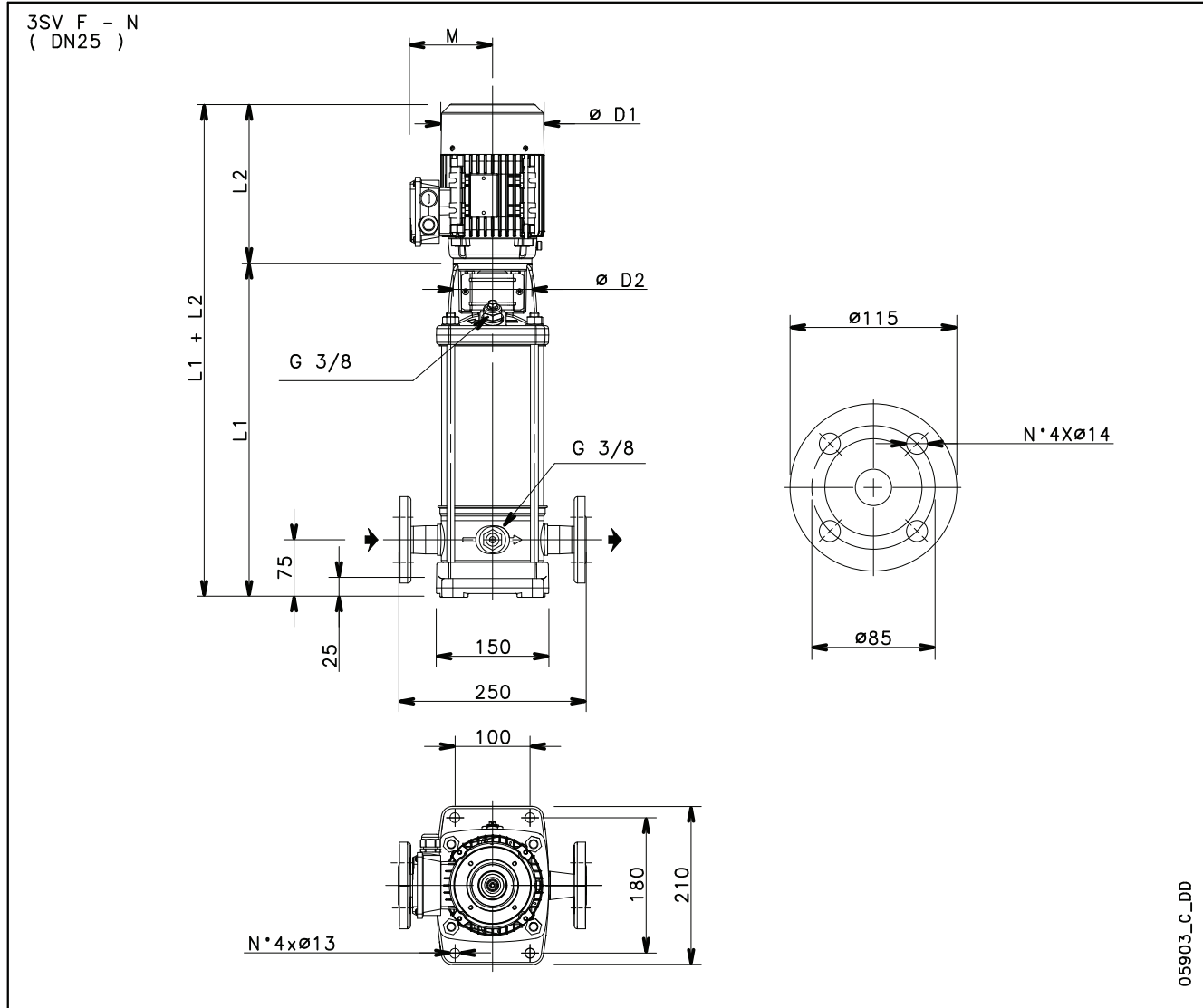

05903_C_DD

PUMP TYPE	MOTOR		DIMENSIONS (mm)								PN	MEI \geq	WEIGHT kg	
	kW	SIZE	L1	L2		M		D1		D2			bar	(1)
3SV03..L..	0,37	71	278	209	209	111	111	120	120	105	25	0,70	8,4	13,2
3SV04..L..	0,37	71	298	209	209	111	111	120	120	105	25	0,70	8,8	13,6
3SV05..L..	0,55	71	318	231	231	121	121	140	140	105	25	0,70	9,2	14
3SV06..L..	0,55	71	338	231	231	121	121	140	140	105	25	0,70	9,7	16,4
3SV07..L./D	0,75	80	368	226	263	121	129	140	155	120	25	0,70	10,9	20,5
3SV08..L./D	0,75	80	388	226	263	121	129	140	155	120	25	0,70	11,3	20,9
3SV09..L./D	1,1	80	408	263	263	137	129	155	155	120	25	0,70	11,7	23,1
3SV10..L./D	1,1	80	428	263	263	137	129	155	155	120	25	0,70	12,1	23,5
3SV11..L./D	1,1	80	448	263	263	137	129	155	155	120	25	0,70	12,5	23,9
3SV12..L./D	1,1	80	468	263	263	137	129	155	155	120	25	0,70	13,3	24,7
3SV13..L./D	1,5	90	498	263	263	137	129	155	155	140	25	0,70	14	27
3SV14..L./D	1,5	90	518	263	263	137	129	155	155	140	25	0,70	14,4	27,5
3SV16..L./D	1,5	90	558	263	263	137	129	155	155	140	25	0,70	15,2	28,2
3SV19..L..	2,2	90	618	298	298	151	134	174	174	140	25	0,70	16,4	34,4
3SV21..L..	2,2	90	658	298	298	151	134	174	174	140	25	0,70	17,2	35,2
3SV23..L..	2,2	90	698	298	298	151	134	174	174	140	25	0,70	18	36
3SV25..L..	2,2	90	738	298	298	151	134	174	174	140	25	0,70	18,9	36,8
3SV27..L..	3	100	788	-	298	-	134	-	174	160	25	0,70	20,7	42,6
3SV29..L..	3	100	828	-	298	-	134	-	174	160	25	0,70	21,5	43,4
3SV31..L..	3	100	868	-	298	-	134	-	174	160	25	0,70	22,3	44,2
3SV33..L..	3	100	908	-	298	-	134	-	174	160	25	0,70	23,1	45

(1) Value referred to the F, N versions.

**3SV..L SERIES - LOW NPSH
OPERATING CHARACTERISTICS AT 50 Hz, 2-POLE**

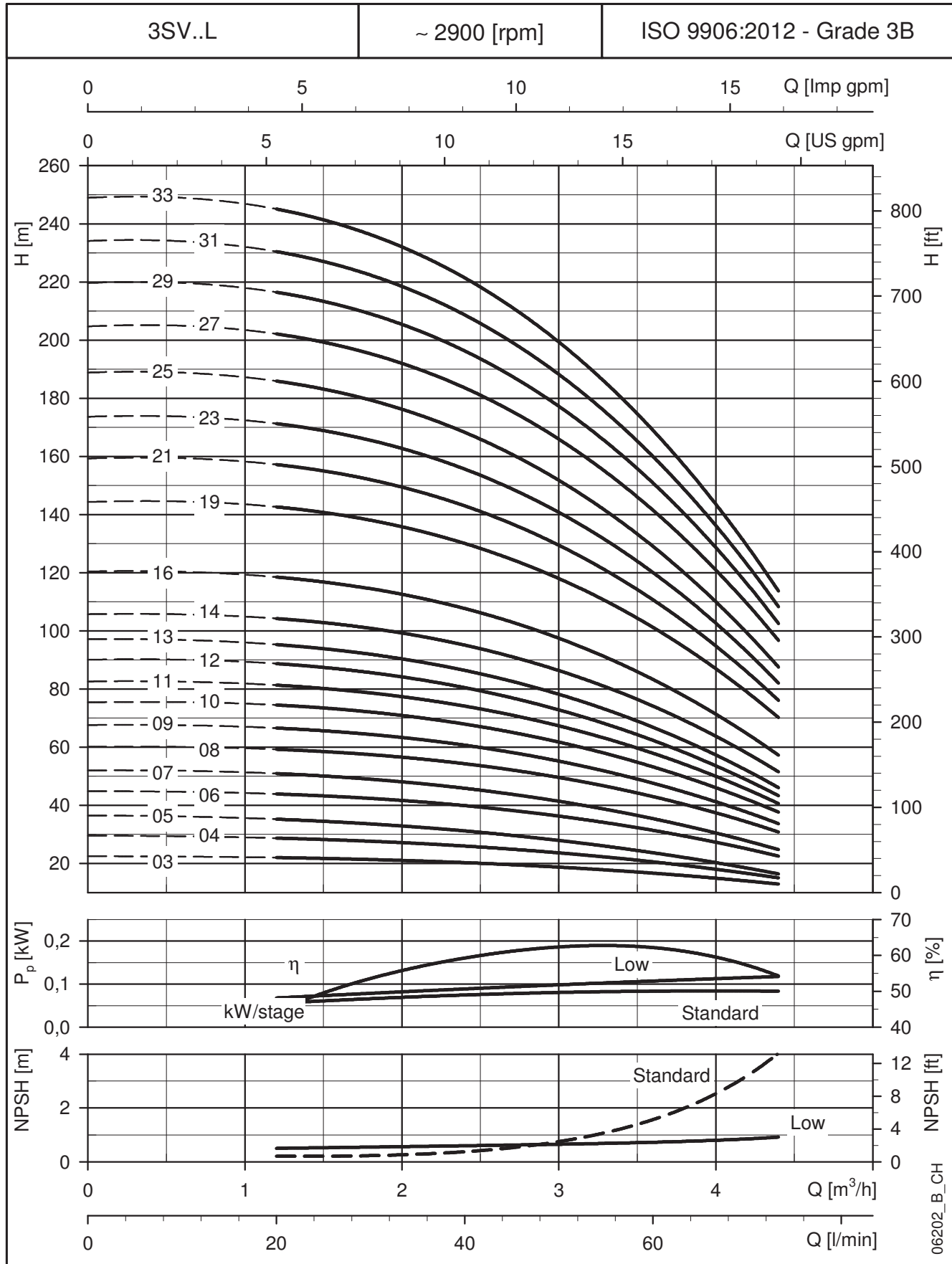

These performances are valid for liquids with density $\rho = 1.0 \text{ Kg/dm}^3$ and kinematic viscosity $\nu = 1 \text{ mm}^2/\text{sec}$.

5SV..L SERIES - LOW NPSH DIMENSIONS AND WEIGHTS AT 50 Hz, 2-POLE

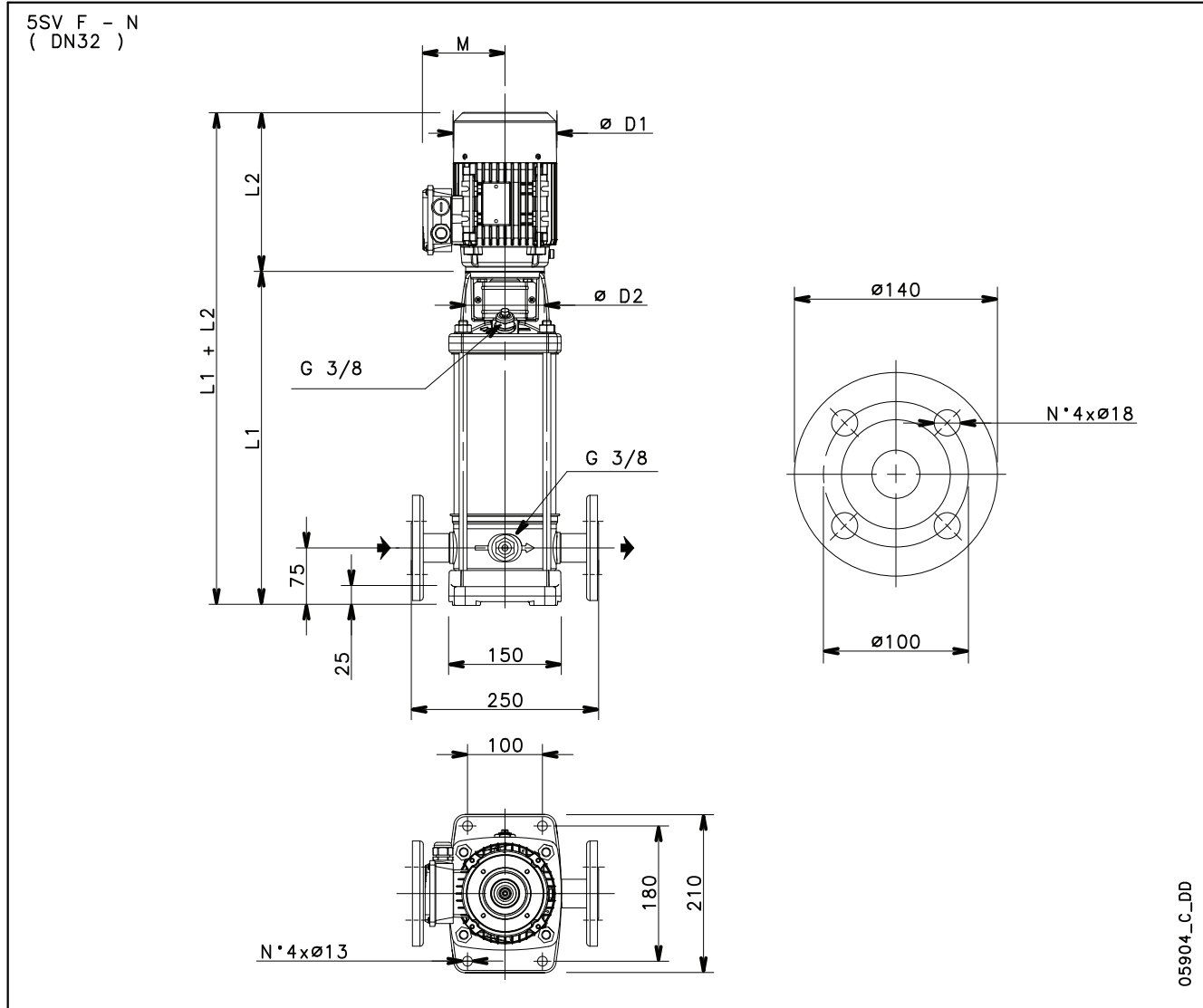

05904_C_DD

PUMP TYPE	MOTOR		DIMENSIONS (mm)								PN	MEI \geq (1)	WEIGHT kg	
	kW	SIZE	L1	1~	3~	1~	3~	1~	3~	D2			PUMP	ELECTRIC PUMP
5SV03..L../D	0,75	80	303	226	263	121	129	140	155	120	25	0,70	9,6	19,2
5SV04..L../D	0,75	80	328	226	263	121	129	140	155	120	25	0,70	10	19,6
5SV05..L../D	1,1	80	353	263	263	137	129	155	155	120	25	0,70	10,5	21,9
5SV06..L../D	1,1	80	378	263	263	137	129	155	155	120	25	0,70	11	22,4
5SV07..L../D	1,5	90	413	263	263	137	129	155	155	140	25	0,70	11,8	25
5SV08..L../D	1,5	90	438	263	263	137	129	155	155	140	25	0,70	12,3	25,6
5SV09..L../D	1,5	90	463	263	263	137	129	155	155	140	25	0,70	12,7	26
5SV10..L../D	1,5	90	488	263	263	137	129	155	155	140	25	0,70	13,2	26,5
5SV11..L..	2,2	90	513	298	298	151	134	174	174	140	25	0,70	13,7	31,9
5SV12..L..	2,2	90	538	298	298	151	134	174	174	140	25	0,70	14,1	32,3
5SV13..L..	2,2	90	563	298	298	151	134	174	174	140	25	0,70	14,6	32,8
5SV14..L..	2,2	90	588	298	298	151	134	174	174	140	25	0,70	15	33,2
5SV15..L..	2,2	90	613	298	298	151	134	174	174	140	25	0,70	15,5	33,7
5SV16..L..	3	100	648	-	298	-	134	-	174	160	25	0,70	17	38
5SV18..L..	3	100	698	-	298	-	134	-	174	160	25	0,70	18	39
5SV21..L..	3	100	773	-	298	-	134	-	174	160	25	0,70	19,4	40,4
5SV23..L..	4	112	823	-	319	-	154	-	197	160	25	0,70	20,4	47
5SV25..L..	4	112	873	-	319	-	154	-	197	160	25	0,70	21,3	48
5SV28..L..	4	112	948	-	319	-	154	-	197	160	25	0,70	23	49,4
5SV30..L..	5,5	132	1018	-	375	-	168	-	214	300	25	0,70	28,1	65,7
5SV33..L..	5,5	132	1093	-	375	-	168	-	214	300	25	0,70	29,5	67,1

(1) Value referred to the F, N versions.

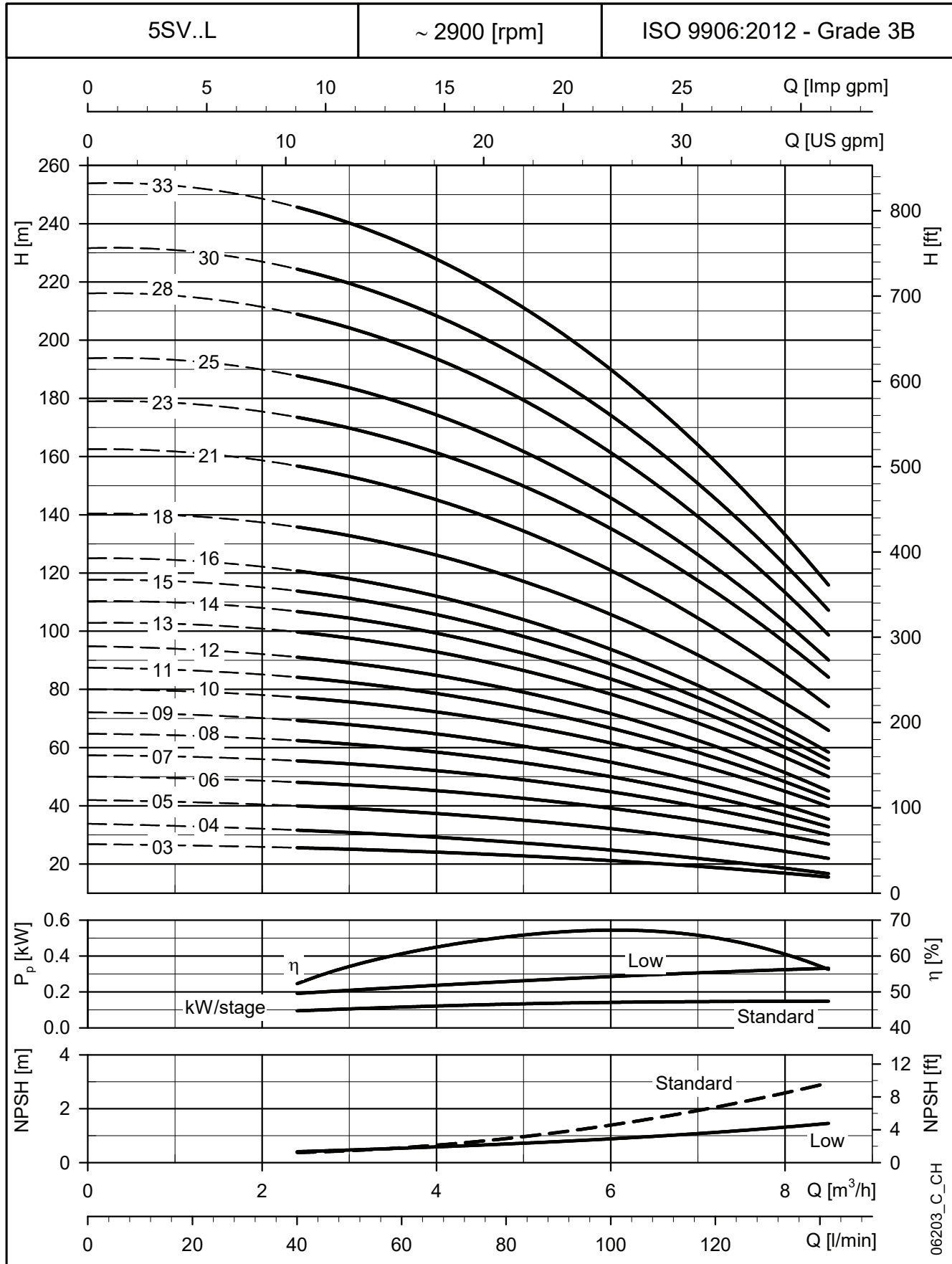
**5SV..L SERIES - LOW NPSH
OPERATING CHARACTERISTICS AT 50 Hz, 2-POLE**

These performances are valid for liquids with density $\rho = 1.0 \text{ Kg/dm}^3$ and kinematic viscosity $\nu = 1 \text{ mm}^2/\text{sec}$.

10SV..L SERIES - LOW NPSH DIMENSIONS AND WEIGHTS AT 50 Hz, 2-POLE

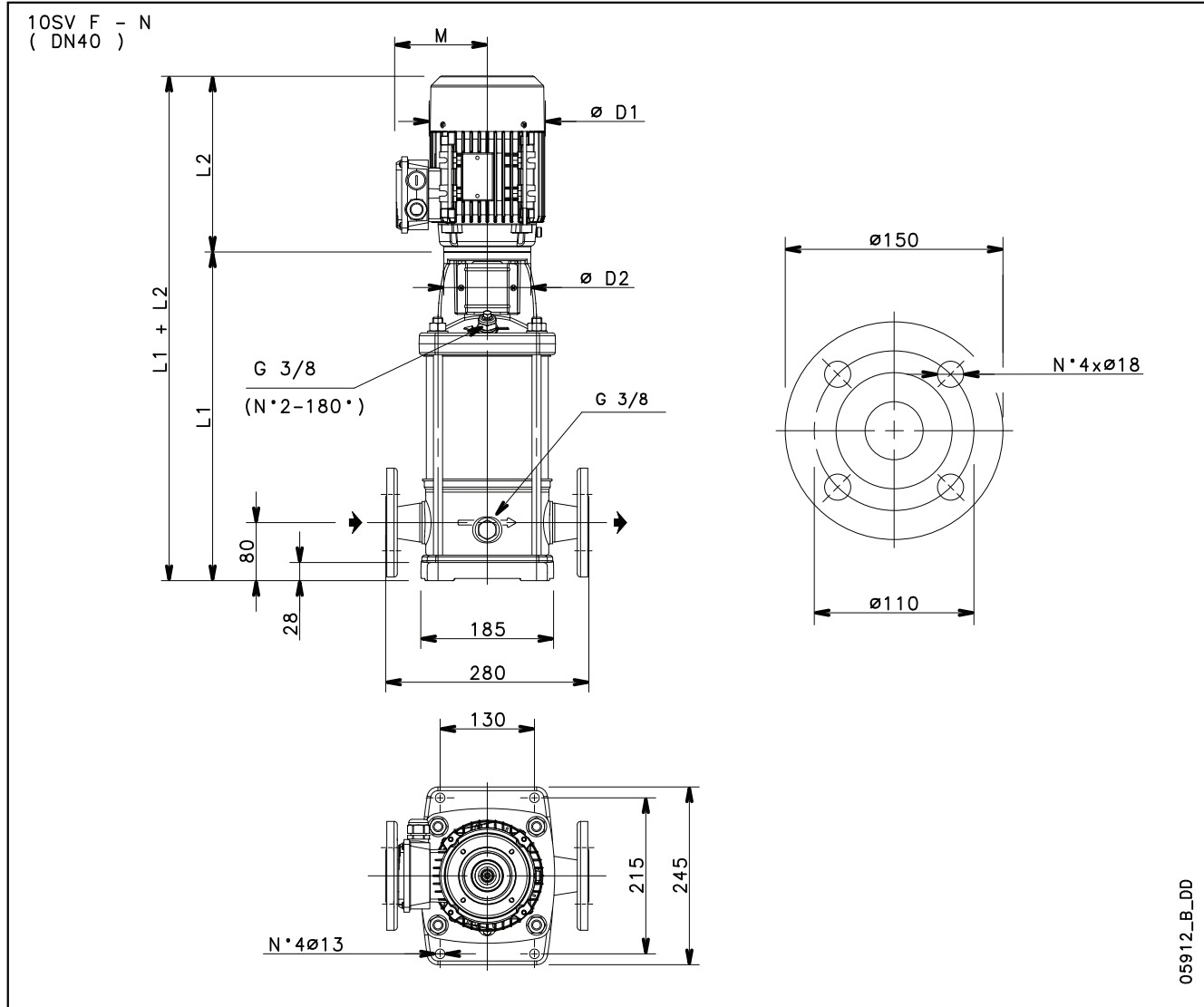

05912_B_DD

PUMP TYPE	MOTOR		DIMENSIONS (mm)								PN bar	MEI \geq (1)	WEIGHT kg	
	kW	SIZE	L1	L2		M		D1		D2			PUMP	ELECTRIC PUMP
10SV03..L../D	1,5	90	399	263	263	137	129	155	155	140	25	0,70	16,6	29,6
10SV04..L..	2,2	90	431	298	298	151	134	174	174	140	25	0,70	17,6	35,8
10SV05..L..	2,2	90	463	298	298	151	134	174	174	140	25	0,70	18,5	36,7
10SV06..L..	3	100	505	-	298	-	134	-	174	160	25	0,70	20,6	41,6
10SV07..L..	3	100	537	-	298	-	134	-	174	160	25	0,70	21,5	42,5
10SV08..L..	3	100	569	-	298	-	134	-	174	160	25	0,70	22,4	43,4
10SV09..L..	4	112	601	-	319	-	154	-	197	160	25	0,70	23,3	49,7
10SV10..L..	4	112	633	-	319	-	154	-	197	160	25	0,70	24,3	50,7
10SV11..L..	5,5	132	732	-	375	-	168	-	214	300	25	0,70	31,2	68,8
10SV13..L..	5,5	132	796	-	375	-	168	-	214	300	25	0,70	33,1	71
10SV15..L..	5,5	132	860	-	375	-	168	-	214	300	25	0,70	35	73
10SV17..L..	7,5	132	924	-	367	-	191	-	256	300	25	0,70	36,9	93
10SV18..L..	7,5	132	956	-	367	-	191	-	256	300	25	0,70	37,8	94
10SV20..L..	7,5	132	1020	-	367	-	191	-	256	300	25	0,70	39,6	96
10SV21..L..	11	160	1082	-	428	-	191	-	256	350	25	0,70	42,2	113

(1) Value referred to the F, N versions.

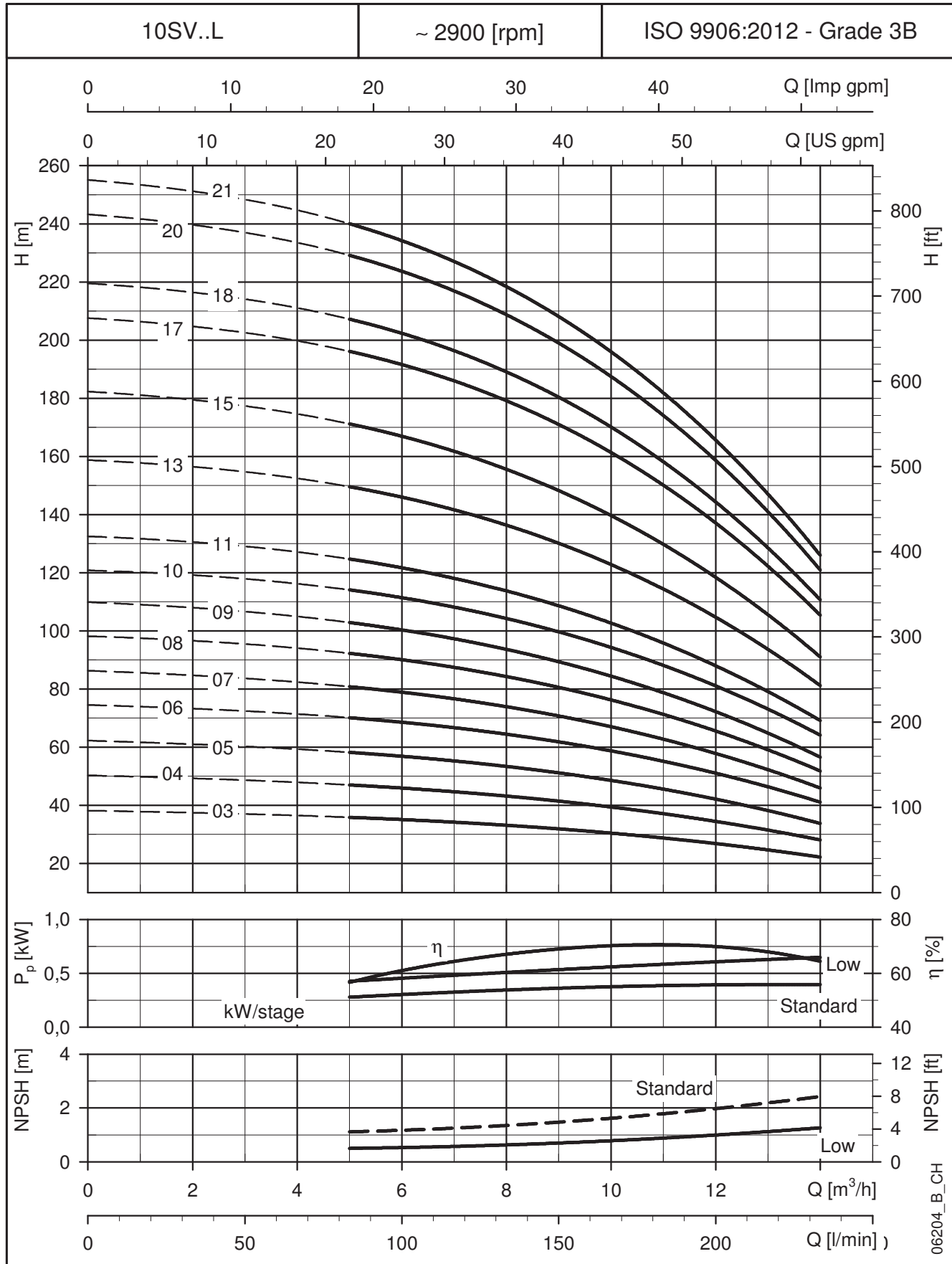
**10SV..L SERIES - LOW NPSH
OPERATING CHARACTERISTICS AT 50 Hz, 2-POLE**

These performances are valid for liquids with density $\rho = 1.0 \text{ Kg/dm}^3$ and kinematic viscosity $\nu = 1 \text{ mm}^2/\text{sec}$.

15SV..L SERIES - LOW NPSH DIMENSIONS AND WEIGHTS AT 50 Hz, 2-POLE

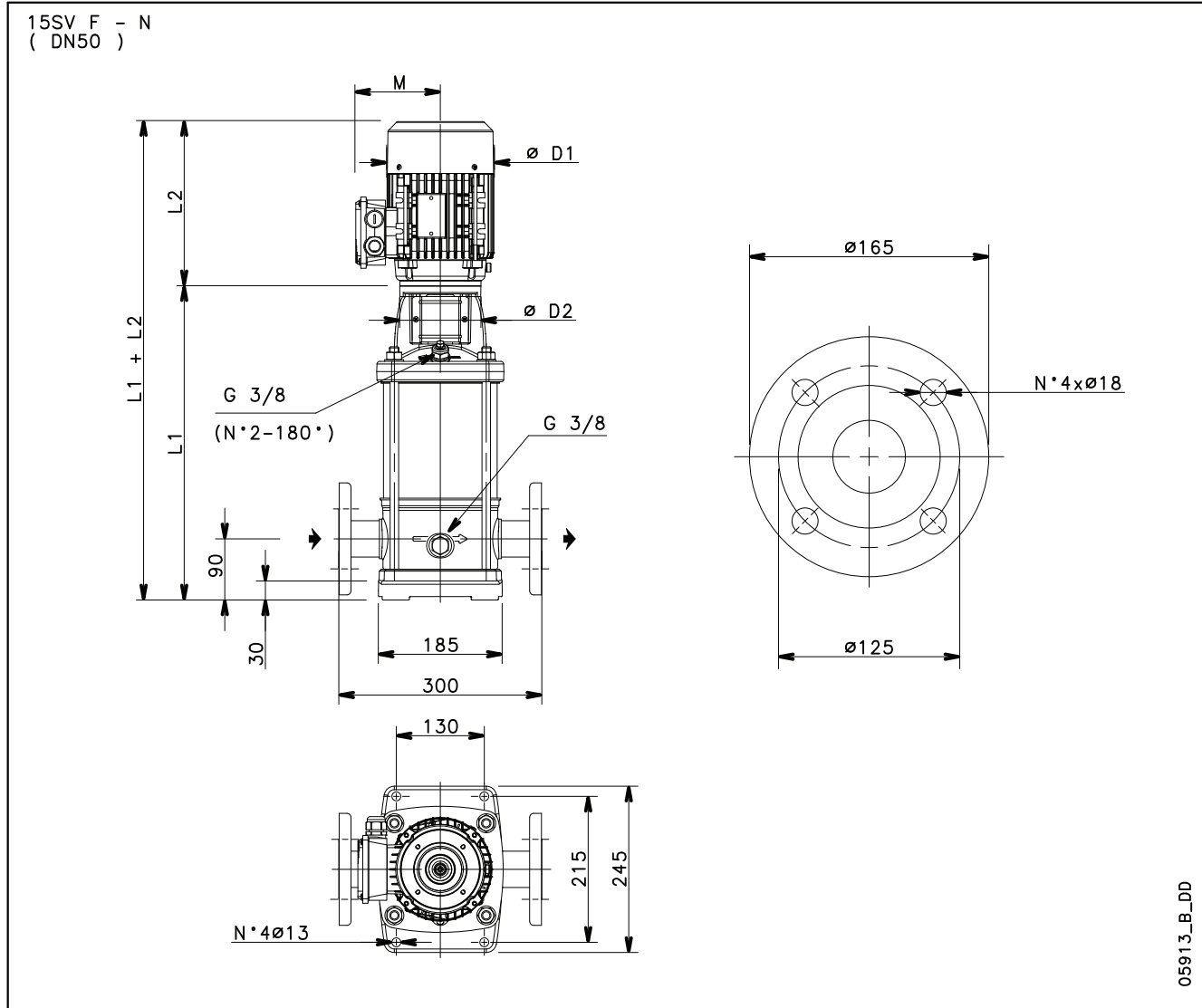

PUMP TYPE	MOTOR		DIMENSIONS (mm)					PN bar	MEI ≥ (1)	WEIGHT kg	
	kW	SIZE	L1	L2	M	D1	D2			PUMP	ELECTRIC PUMP
15SV02..L..	3	100	419	298	134	174	160	25	0,70	17,6	36,6
15SV03..L..	4	112	467	319	154	197	160	25	0,70	19	45,4
15SV04..L..	4	112	515	319	154	197	160	25	0,70	20,3	46,8
15SV05..L..	5,5	132	630	375	168	214	300	25	0,70	27,6	65,2
15SV06..L..	5,5	132	678	375	168	214	300	25	0,70	28,9	67
15SV07..L..	7,5	132	726	367	191	256	300	25	0,70	30,2	86
15SV08..L..	7,5	132	774	367	191	256	300	25	0,70	31,5	88
15SV09..L..	11	160	852	428	191	256	350	25	0,70	35,7	106
15SV10..L..	11	160	900	428	191	256	350	25	0,70	37	108
15SV11..L..	11	160	948	428	191	256	350	25	0,70	38,3	109
15SV13..L..	11	160	1044	428	191	256	350	25	0,70	41	112
15SV15..L..	15	160	1140	494	240	313	350	25	0,70	43,7	146
15SV17..L..	15	160	1236	494	240	313	350	25	0,70	46,7	149

(1) Value referred to the F, N versions.

**15SV..L SERIES - LOW NPSH
OPERATING CHARACTERISTICS AT 50 Hz, 2-POLE**

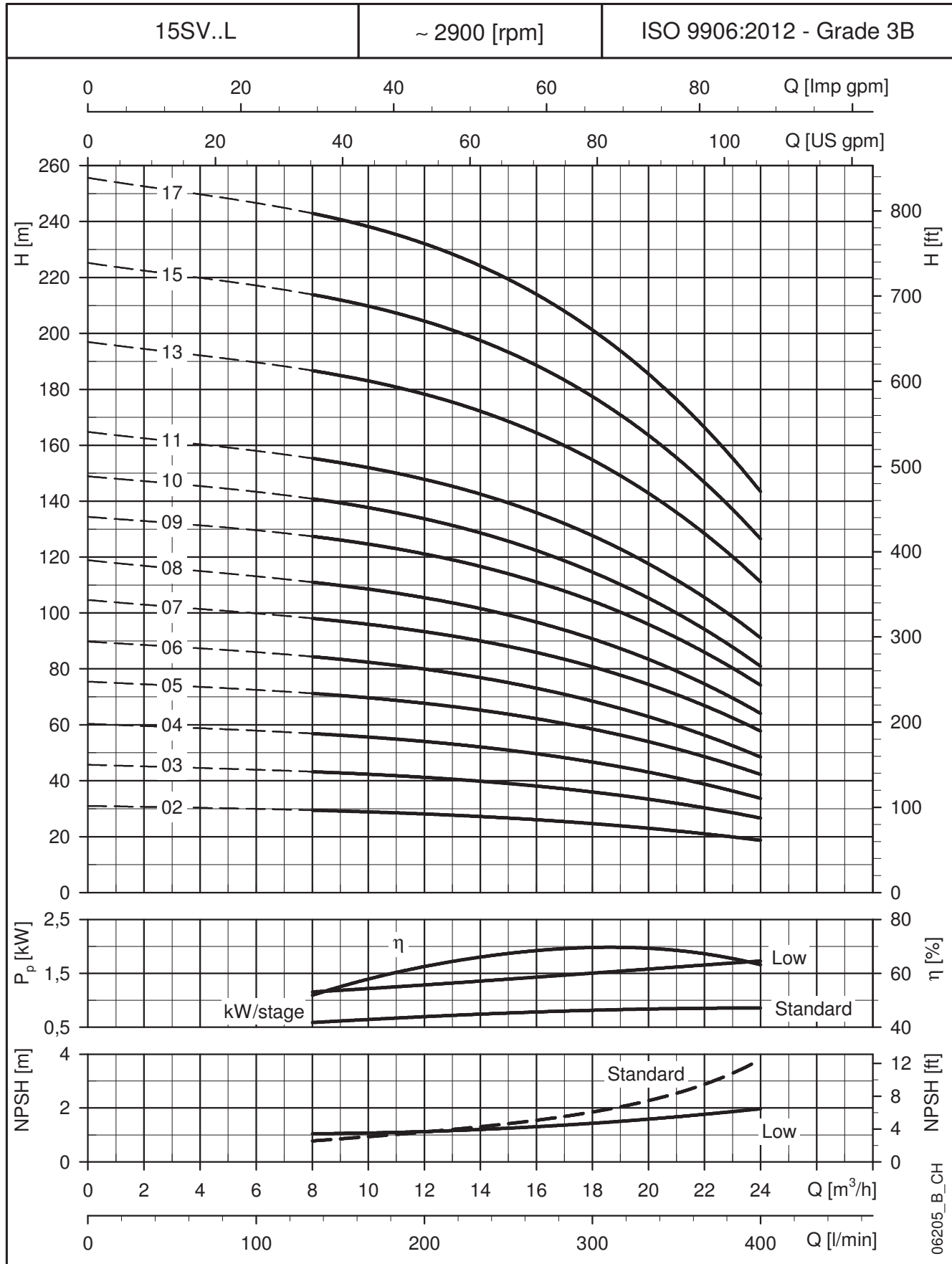

These performances are valid for liquids with density $\rho = 1.0 \text{ Kg/dm}^3$ and kinematic viscosity $\nu = 1 \text{ mm}^2/\text{sec}$.

22SV..L SERIES - LOW NPSH DIMENSIONS AND WEIGHTS AT 50 Hz, 2-POLE

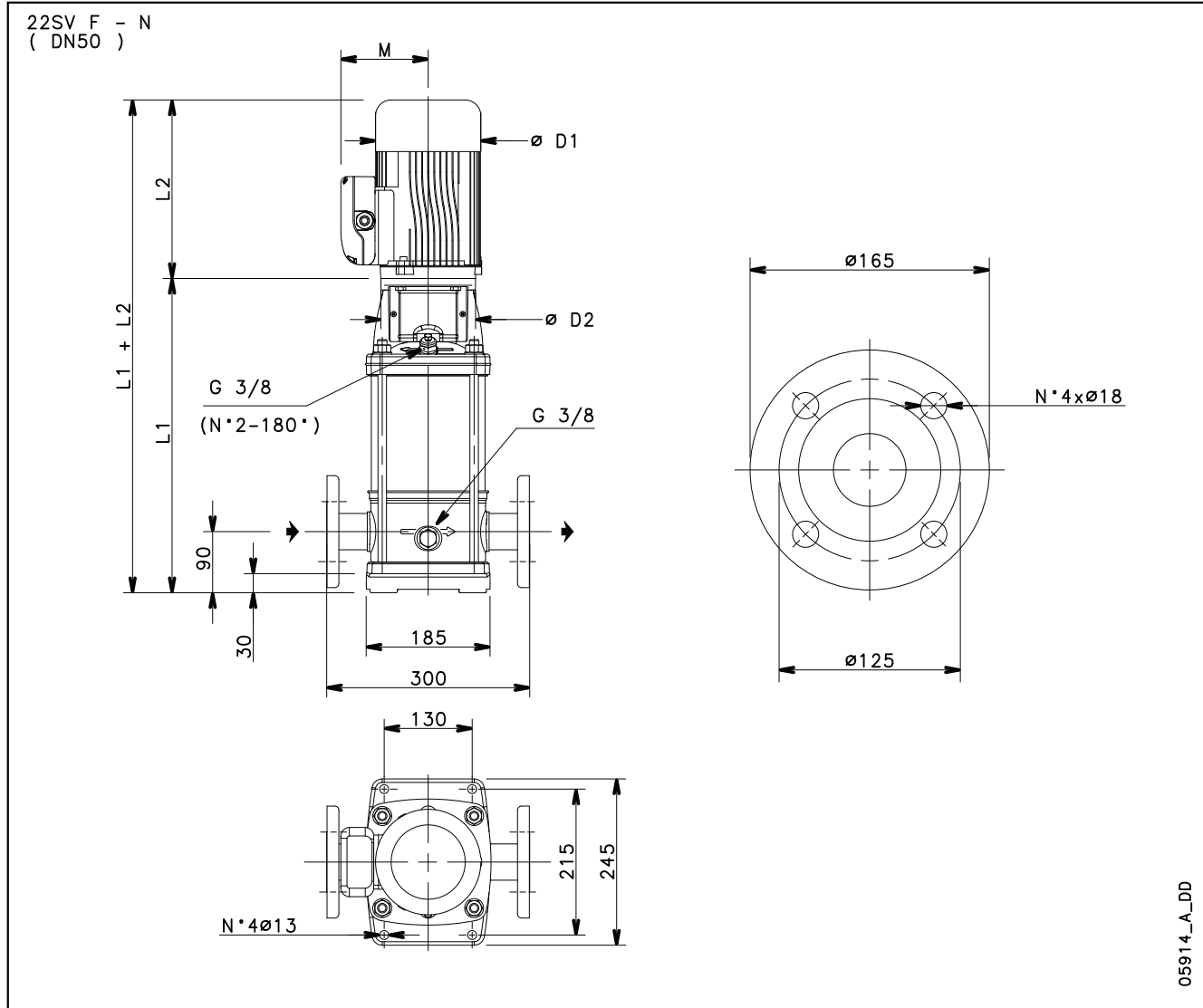

PUMP TYPE	MOTOR		DIMENSIONS (mm)					PN	MEI ≥ (1)	WEIGHT kg	
	kW	SIZE	L1	L2	M	D1	D2			PUMP	ELECTRIC PUMP
22SV02..L..	3	100	419	298	134	174	160	25	0,70	18	39
22SV03..L..	4	112	467	319	154	197	160	25	0,70	19,4	46
22SV04..L..	5,5	132	582	375	168	214	300	25	0,70	25,4	63
22SV05..L..	5,5	132	630	375	168	214	300	25	0,70	26,7	65
22SV06..L..	7,5	132	678	367	191	256	300	25	0,70	28	84
22SV07..L..	11	160	756	428	191	256	350	25	0,70	31,8	102
22SV08..L..	11	160	804	428	191	256	350	25	0,70	33,1	104
22SV09..L..	11	160	852	428	191	256	350	25	0,70	34,4	105
22SV10..L..	11	160	900	428	191	256	350	25	0,70	35,8	107
22SV12..L..	15	160	996	494	240	313	350	25	0,70	38,4	141
22SV14..L..	15	160	1092	494	240	313	350	25	0,70	41,1	144
22SV17..L..	18,5	160	1236	494	240	313	350	25	0,70	45,1	156

(1) Value referred to the F, N versions.

**22SV..L SERIES - LOW NPSH
OPERATING CHARACTERISTICS AT 50 Hz, 2-POLE**

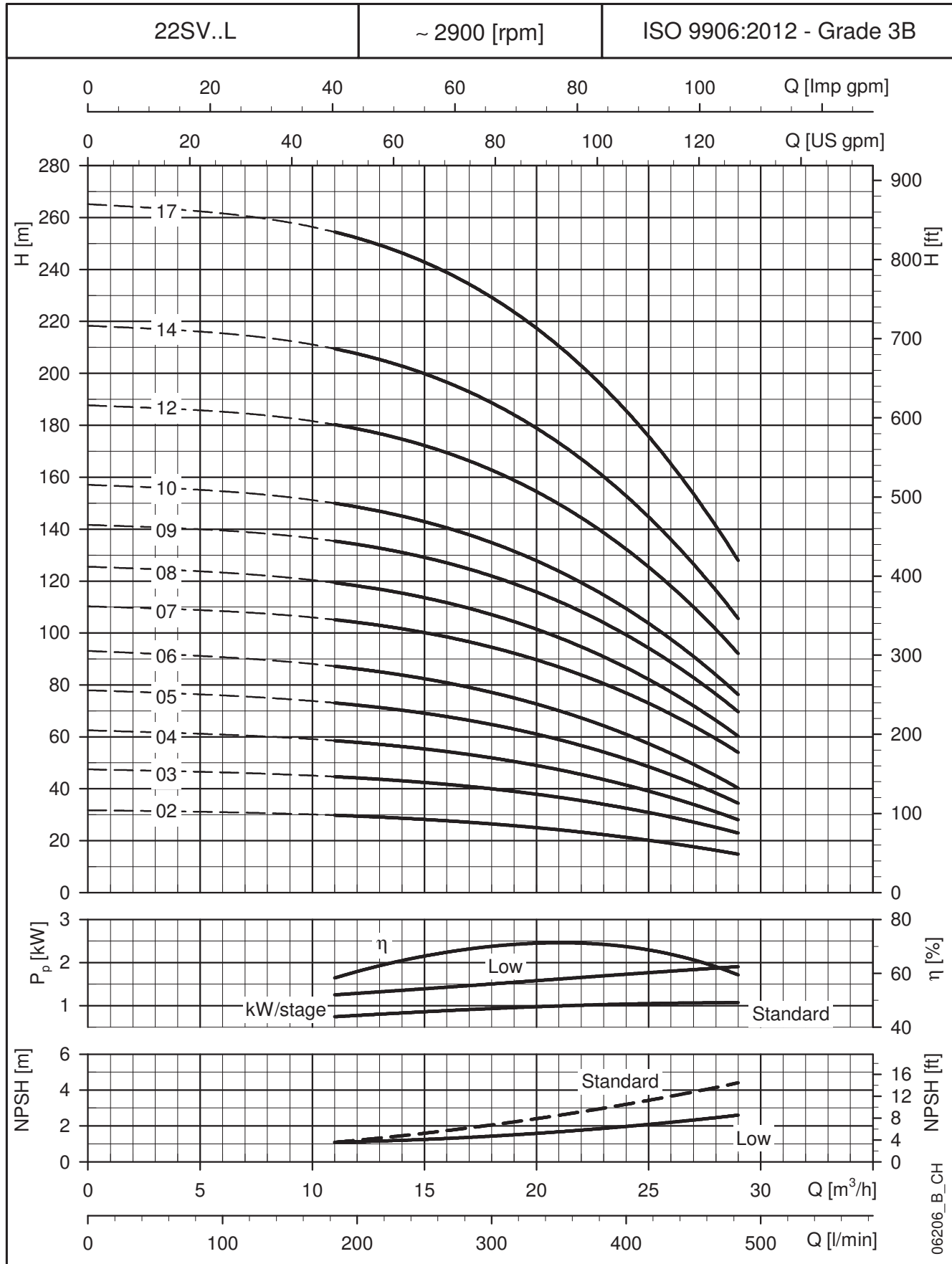

These performances are valid for liquids with density $\rho = 1.0 \text{ Kg/dm}^3$ and kinematic viscosity $\nu = 1 \text{ mm}^2/\text{sec}$.

**33SV..L SERIES - LOW NPSH
DIMENSIONS AND WEIGHTS AT 50 Hz, 2-POLE**

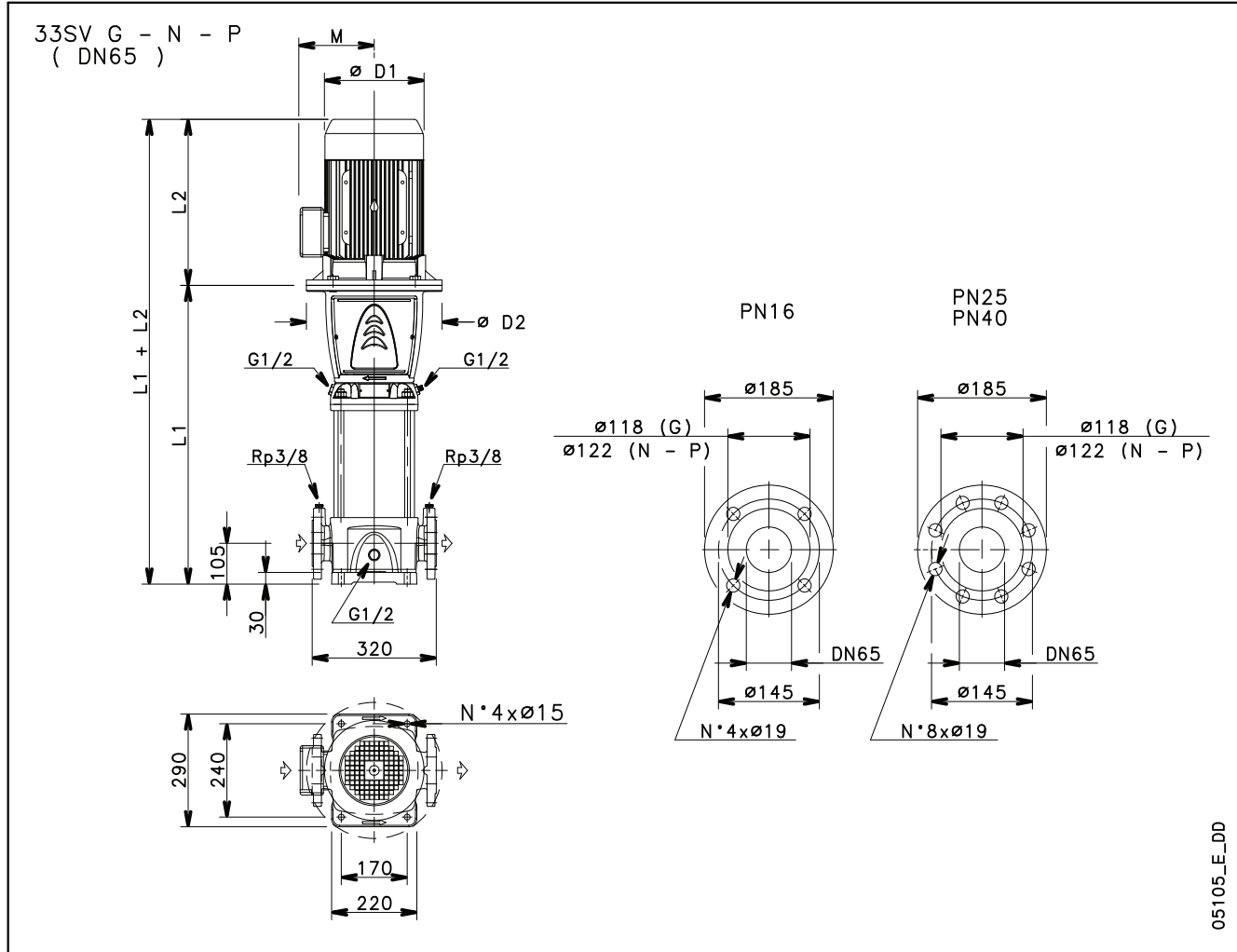

PUMP TYPE	MOTOR kW	MOTOR SIZE	DIMENSIONS (mm)							MEI ≥ (1)	WEIGHT kg		PUMP TYPE	MOTOR kW	MOTOR SIZE	DIMENSIONS (mm)							MEI ≥ (1)	WEIGHT kg	
			L1	L2	M	D1	D2	PN	PUMP		ELECTRIC PUMP	L1				L2	M	D1	D2	PN	PUMP	ELECTRIC PUMP			
33SV2/1A..L..	5.5	132	584	375	168	214	300	16	0.70	61	99	33SV8/2A..L..	18.5	160	1069	494	240	313	350	25	88	199			
33SV2..L..	5.5	132	584	375	168	214	300	16		61	99	33SV8/1A..L..	22	180	1069	494	240	313	350	25	89	211			
33SV3/2A..L..	7.5	132	659	367	191	256	300	16		65	121	33SV8..L..	22	180	1069	494	240	313	350	25	89	211			
33SV3/1A..L..	7.5	132	659	367	191	256	300	16		65	121	33SV9/2A..L..	22	180	1144	494	240	313	350	25	93	215			
33SV3..L..	7.5	132	659	367	191	256	300	16		65	121	33SV9/1A..L..	22	180	1144	494	240	313	350	25	93	215			
33SV4/2A..L..	11	160	769	428	191	256	350	16		73	144	33SV9..L..	22	180	1144	494	240	313	350	25	93	215			
33SV4/1A..L..	11	160	769	428	191	256	350	16		73	144	33SV10/2A..L..	30	200	1219	671	285	408	400	25	104	312			
33SV4..L..	11	160	769	428	191	256	350	16		73	144	33SV10/1A..L..	30	200	1219	671	285	408	400	25	104	312			
33SV5/2A..L..	11	160	844	428	191	256	350	16		77	148	33SV10..L..	30	200	1219	671	285	408	400	25	104	312			
33SV5/1A..L..	15	160	844	494	240	313	350	16		77	179	33SV11/2A..L..	30	200	1294	671	285	408	400	40	-	118	326		
33SV5..L..	15	160	844	494	240	313	350	16		77	179	33SV11/1A..L..	30	200	1294	671	285	408	400	40	-	118	326		
33SV6/2A..L..	15	160	919	494	240	313	350	16		81	183	33SV11..L..	30	200	1294	671	285	408	400	40	-	118	326		
33SV6/1A..L..	15	160	919	494	240	313	350	25		81	183	33SV12/2A..L..	30	200	1369	671	285	408	400	40	-	122	330		
33SV6..L..	15	160	919	494	240	313	350	25		81	183	33SV12/1A..L..	30	200	1369	671	285	408	400	40	-	122	330		
33SV7/2A..L..	18.5	160	994	494	240	313	350	25		84	195	33SV12..L..	30	200	1369	671	285	408	400	40	-	122	330		
33SV7/1A..L..	18.5	160	994	494	240	313	350	25		84	195	33SV13/2A..L..	30	200	1444	671	285	408	400	40	-	127	335		
33SV7..L..	18.5	160	994	494	240	313	350	25		84	195	33SV13/1A..L..	37	200	1444	671	285	408	400	40	-	127	351		

(1) Value referred to the G and N versions with PN ≤ 25 bar (2500 kPa). G and N versions with PN > 25 bar (2500 kPa) excluded.

**33SV..L SERIES - LOW NPSH
OPERATING CHARACTERISTICS AT 50 Hz, 2-POLE**

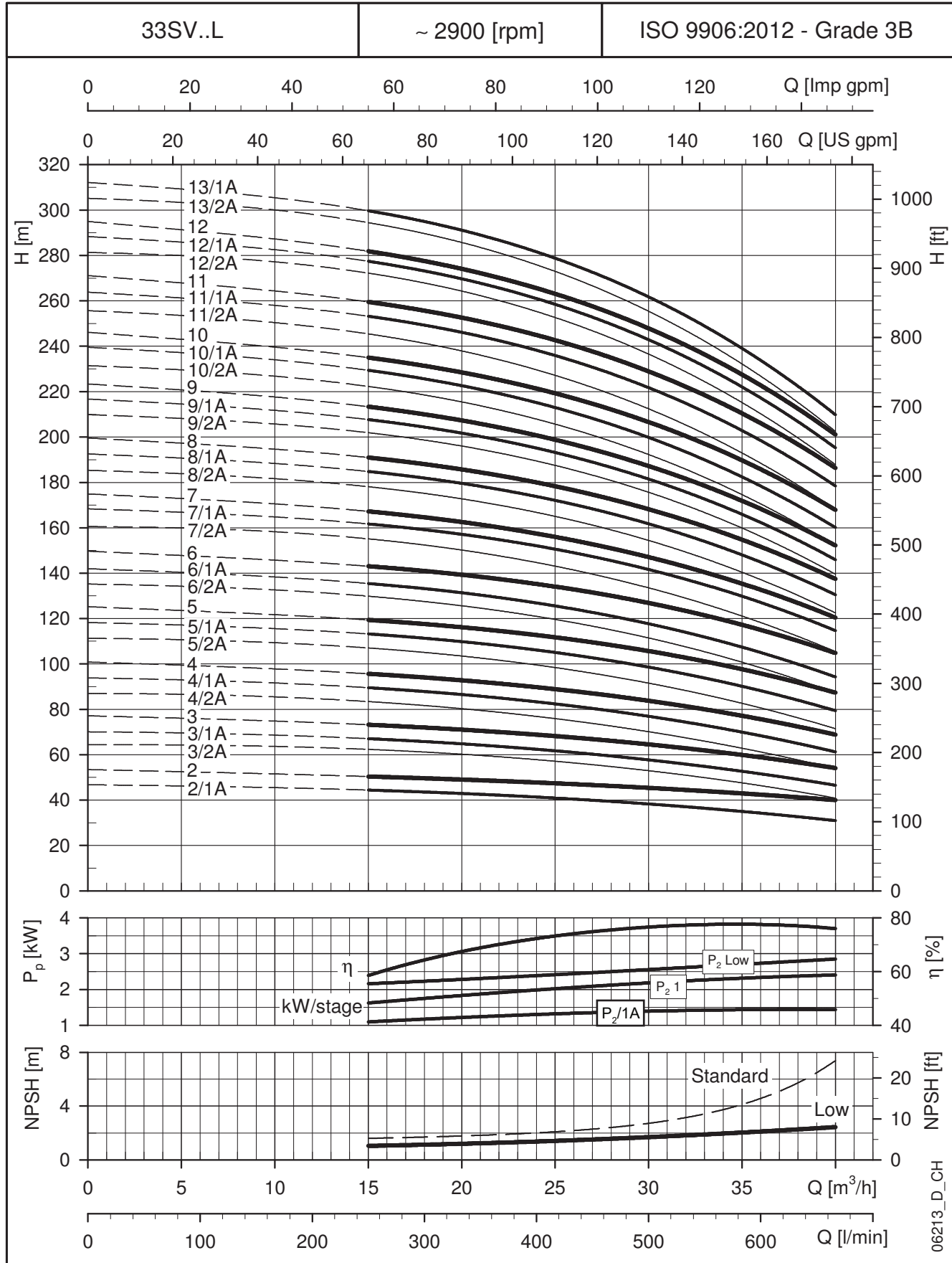

These performances are valid for liquids with density $\rho = 1.0 \text{ Kg/dm}^3$ and kinematic viscosity $\nu = 1 \text{ mm}^2/\text{sec}$.

46SV..L SERIES - LOW NPSH DIMENSIONS AND WEIGHTS AT 50 Hz, 2-POLE

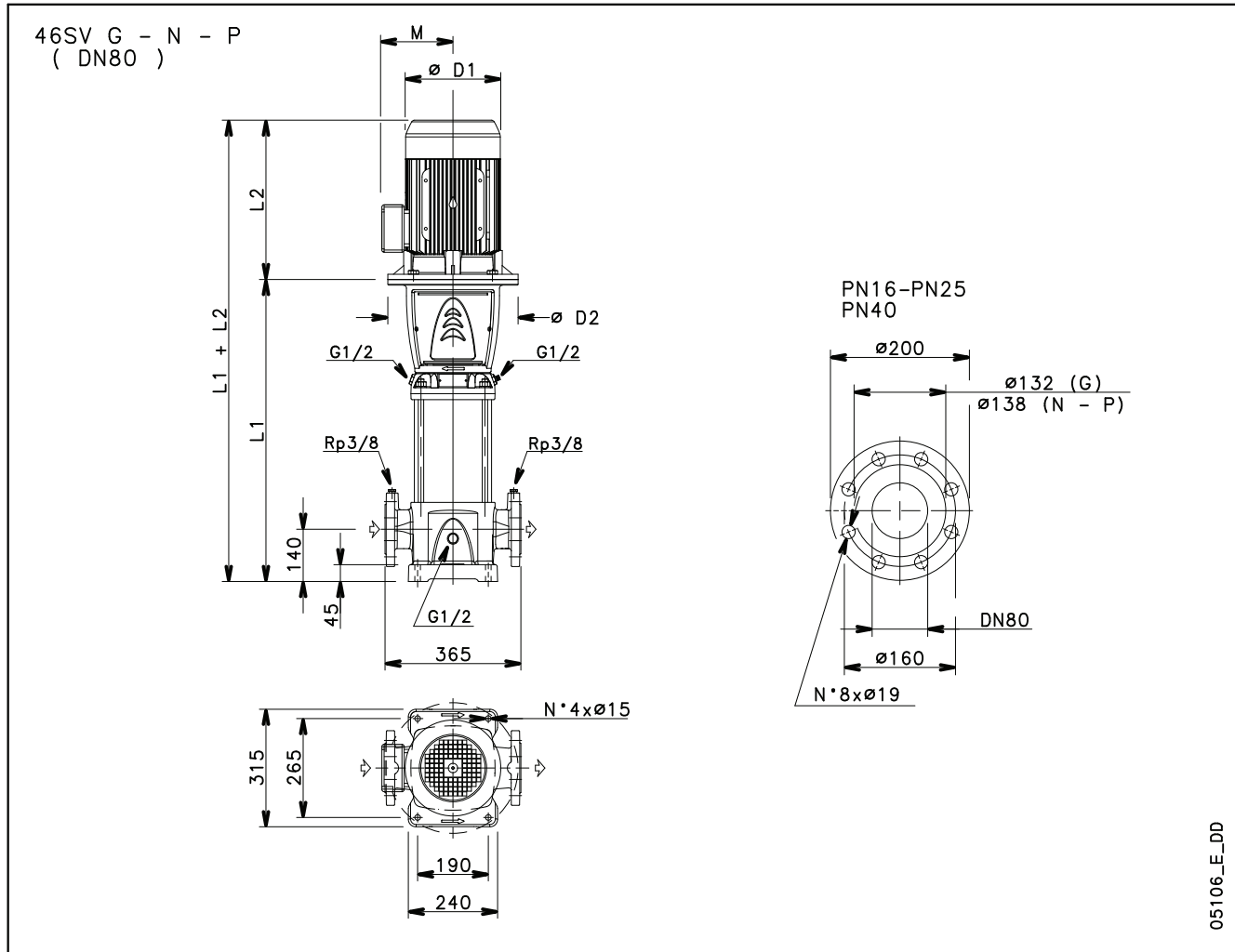

PUMP TYPE	MOTOR		DIMENSIONS (mm)							MEI ≥ (1)	WEIGHT kg		PUMP	ELECTRIC PUMP										
	kW	SIZE	L1	L2	M	D1	D2	PN	PUMP		ELECTRIC PUMP													
46SV2/1A..L..	7,5	132	624	367	191	256	300	16	0,70	66	122	46SV10..L..	37	200	1259	671	285	408	400	40	-	114	338	
46SV2..L..	11	160	659	428	191	256	350	16		70	141	46SV11/2A..L..	45	225	1334	701	309	460	450	40	-	126	418	
46SV3/2A..L..	11	160	734	428	191	256	350	16		74	145	46SV11..L..	45	225	1334	701	309	460	450	40	-	126	418	
46SV3..L..	15	160	734	494	240	313	350	16		74	176	46SV12/2A..L..	45	225	1409	701	309	460	450	40	-	131	423	
46SV4/2A..L..	15	160	809	494	240	313	350	16		78	180	46SV12..L..	45	225	1409	701	309	460	450	40	-	131	423	
46SV4..L..	15	160	809	494	240	313	350	16		78	180													
46SV5/2A..L..	18,5	160	884	494	240	313	350	16		82	193													
46SV5..L..	18,5	160	884	494	240	313	350	16		82	193													
46SV6/2A..L..	22	180	959	494	240	313	350	25		87	209													
46SV6..L..	22	180	959	494	240	313	350	25		87	209													
46SV7/2A..L..	30	200	1034	671	285	408	400	25		97	305													
46SV7..L..	30	200	1034	671	285	408	400	25		97	305													
46SV8/2A..L..	30	200	1109	671	285	408	400	25		101	309													
46SV8..L..	30	200	1109	671	285	408	400	25		101	309													
46SV9/2A..L..	37	200	1184	671	285	408	400	25		105	329													
46SV9..L..	37	200	1184	671	285	408	400	25		105	329													
46SV10/2A..L..	37	200	1259	671	285	408	400	40		-	114	338												

(1) Value referred to the G and N versions with PN ≤ 25 bar (2500 kPa). G and N versions with PN > 25 bar (2500 kPa) excluded.

46SV..L SERIES - LOW NPSH OPERATING CHARACTERISTICS AT 50 Hz, 2-POLE

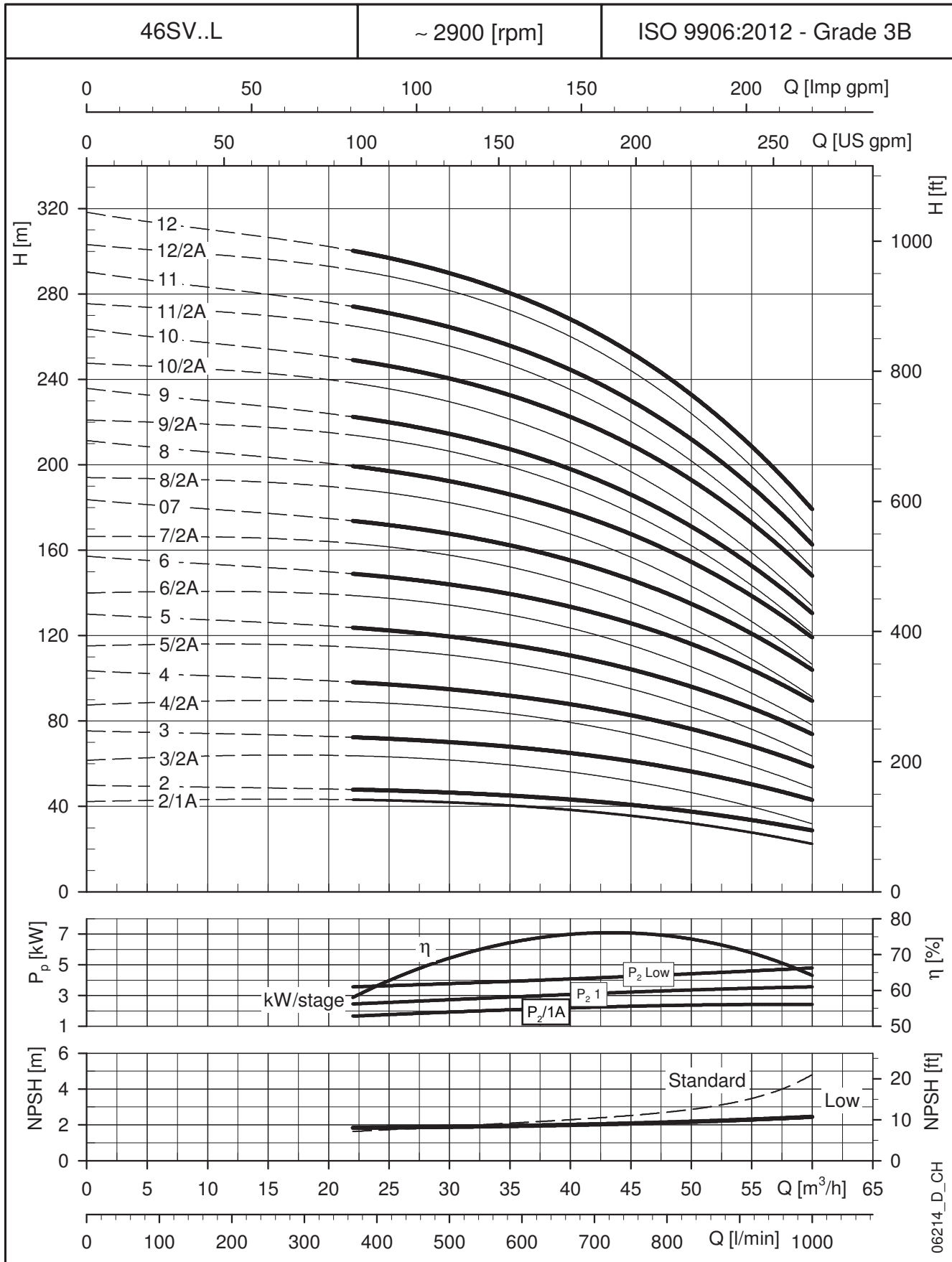

These performances are valid for liquids with density $\rho = 1.0 \text{ Kg/dm}^3$ and kinematic viscosity $\nu = 1 \text{ mm}^2/\text{sec}$.

66SV..L SERIES - LOW NPSH DIMENSIONS AND WEIGHTS AT 50 Hz, 2-POLE

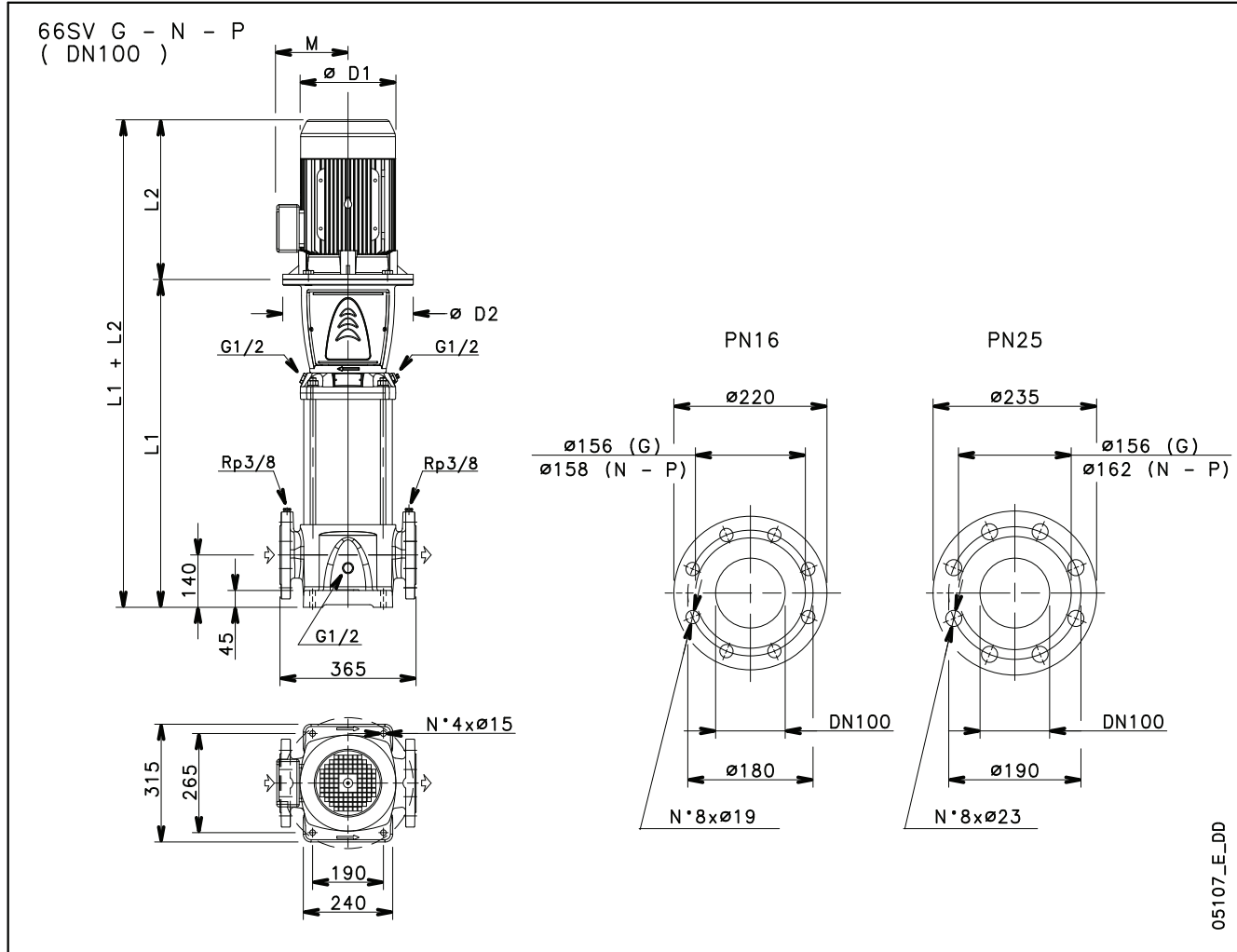

PUMP TYPE	MOTOR kW	MOTOR SIZE	DIMENSIONS (mm)						MEI \geq (1)	WEIGHT kg	
			L1	L2	M	D1	D2	PN		PUMP	ELECTRIC PUMP
66SV2/1A..L..	11	160	699	428	191	256	350	16	0,70	81	152
66SV2..L..	15	160	699	494	240	313	350	16		81	183
66SV3/2A..L..	15	160	789	494	240	313	350	16		86	188
66SV3/1A..L..	18,5	160	789	494	240	313	350	16		86	197
66SV3..L..	18,5	160	789	494	240	313	350	16		86	197
66SV4/2A..L..	22	180	879	494	240	313	350	16		93	215
66SV4/1A..L..	22	180	879	494	240	313	350	16		93	215
66SV4..L..	30	200	879	671	317	402	400	16		100	315
66SV5/2A..L..	30	200	969	671	285	408	400	16		105	313
66SV5/1A..L..	30	200	969	671	285	408	400	16		105	313
66SV5..L..	30	200	969	671	285	408	400	16		105	313
66SV6/2A..L..	30	200	1059	671	285	408	400	25		113	321
66SV6/1A..L..	37	200	1059	671	285	408	400	25		113	337
66SV6..L..	37	200	1059	657	317	402	400	25		113	337
66SV7/2A..L..	37	200	1149	657	317	402	400	25		118	342
66SV7/1A..L..	37	200	1149	657	317	402	400	25		118	342
66SV7..L..	45	225	1149	701	309	460	450	25	122	414	
66SV8/2A..L..	45	225	1239	701	309	460	450	25	0,70	127	419
66SV8/1A..L..	45	225	1239	701	309	460	450	25		127	419
66SV8..L..	45	225	1239	701	309	460	450	25		127	419

(1) Value referred to the G and N versions.

**66SV..L SERIES - LOW NPSH
OPERATING CHARACTERISTICS AT 50 Hz, 2-POLE**

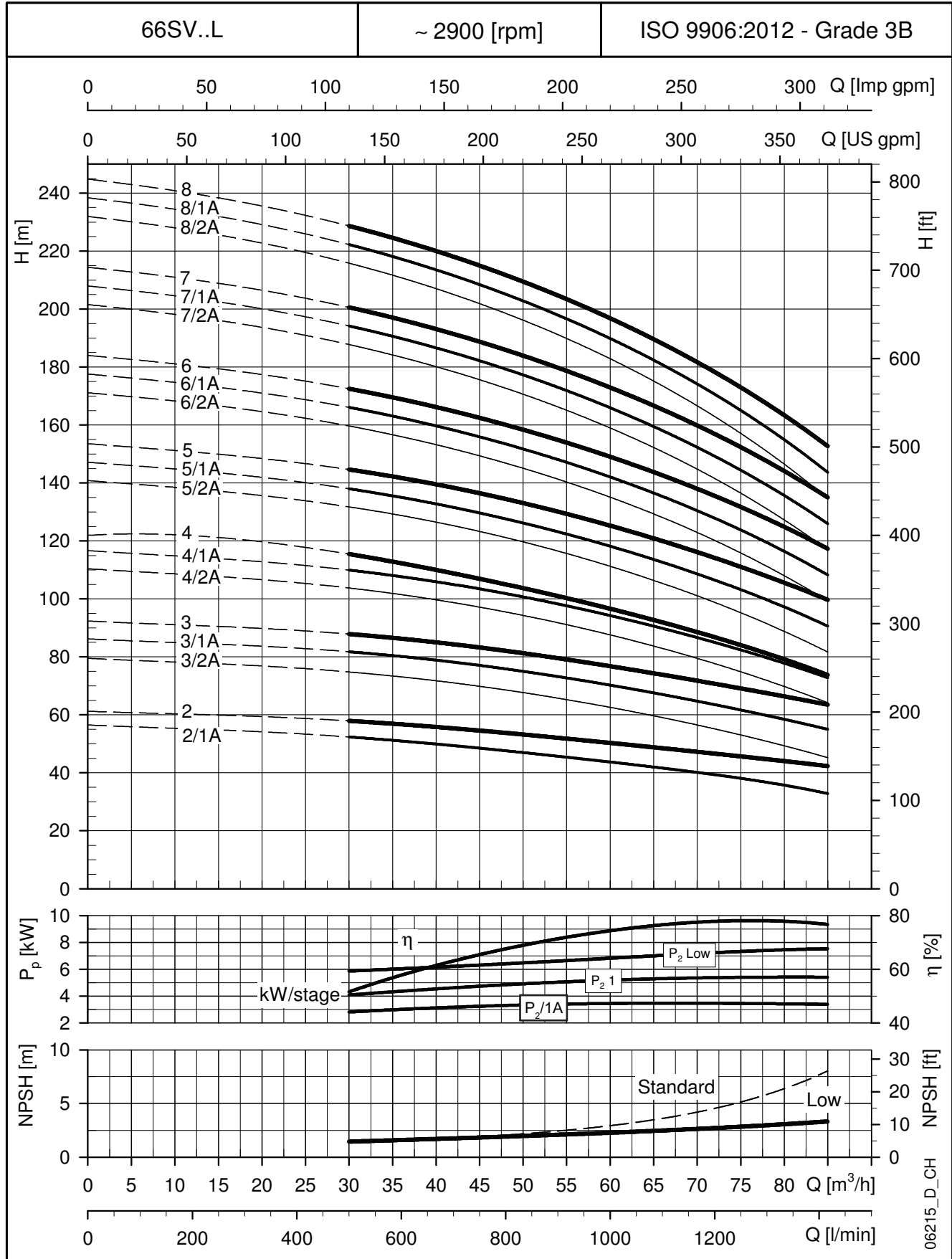

These performances are valid for liquids with density $\rho = 1.0 \text{ Kg/dm}^3$ and kinematic viscosity $\nu = 1 \text{ mm}^2/\text{sec}$.

1SV..L SERIES - LOW NPSH DIMENSIONS AND WEIGHTS AT 60 Hz, 2-POLE

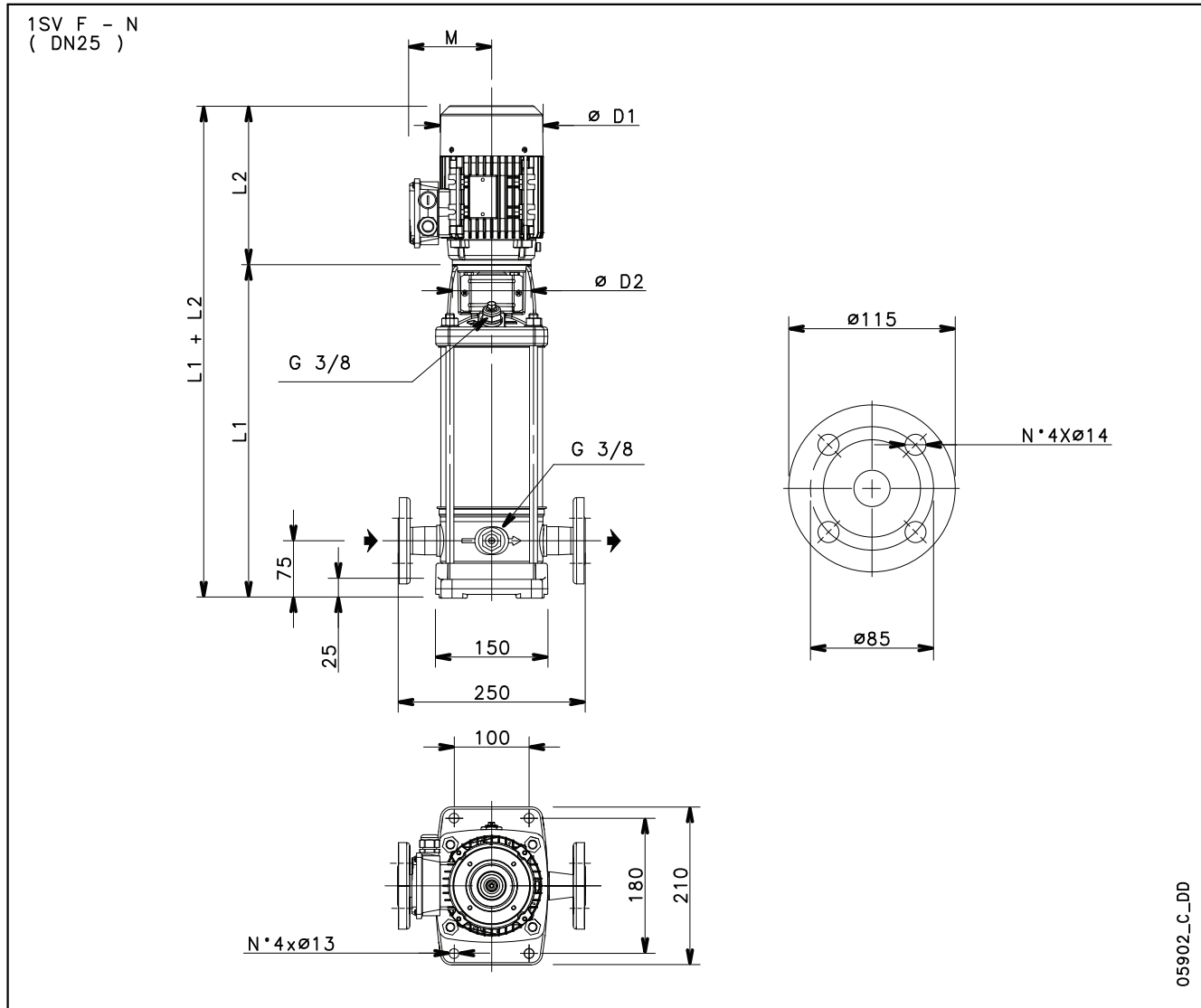

PUMP TYPE	MOTOR		DIMENSIONS (mm)								WEIGHT kg	
	kW	SIZE	L1	L2		M		D1		D2	PUMP	ELECTRIC
				1~	3~	1~	3~	1~	3~			
1SV03..L..	0,37	71	278	209	209	111	111	120	120	105	8,6	13,4
1SV04..L..	0,37	71	298	209	209	111	111	120	120	105	9	13,8
1SV05..L..	0,55	71	318	231	231	121	121	140	140	105	9,4	16,1
1SV06..L..	0,55	71	338	231	231	121	121	140	140	105	9,8	16,5
1SV07..L./D	0,75	80	368	226	263	121	129	140	155	120	10,6	20,2
1SV08..L./D	0,75	80	388	226	263	121	129	140	155	120	11	20,6
1SV09..L./D	1,1	80	408	263	263	137	129	155	155	120	11,4	21
1SV10..L./D	1,1	80	428	263	263	137	129	155	155	120	11,8	23,2
1SV11..L./D	1,1	80	448	263	263	137	129	155	155	120	12,2	23,6
1SV12..L./D	1,1	80	468	263	263	137	129	155	155	120	12,6	24
1SV13..L./D	1,1	80	488	263	263	137	129	155	155	120	13	24,4
1SV15..L./D	1,5	90	538	263	263	137	129	155	155	140	14,1	27
1SV17..L./D	1,5	90	578	263	263	137	129	155	155	140	14,9	28
1SV18..L..	2,2	90	598	298	298	151	134	174	174	140	15,3	33,5
1SV20..L..	2,2	90	638	298	298	151	134	174	174	140	16,1	34,3
1SV22..L..	2,2	90	678	298	298	151	134	174	174	140	16,9	35
1SV24..L..	2,2	90	718	298	298	151	134	174	174	140	17,7	35,8
1SV26..L..	2,2	90	758	298	298	151	134	174	174	140	18,5	36,6
1SV28..L..	3	100	808	-	298	-	134	-	174	140	19,7	40,7

**1SV..L SERIES - LOW NPSH
OPERATING CHARACTERISTICS AT 60 Hz, 2-POLE**

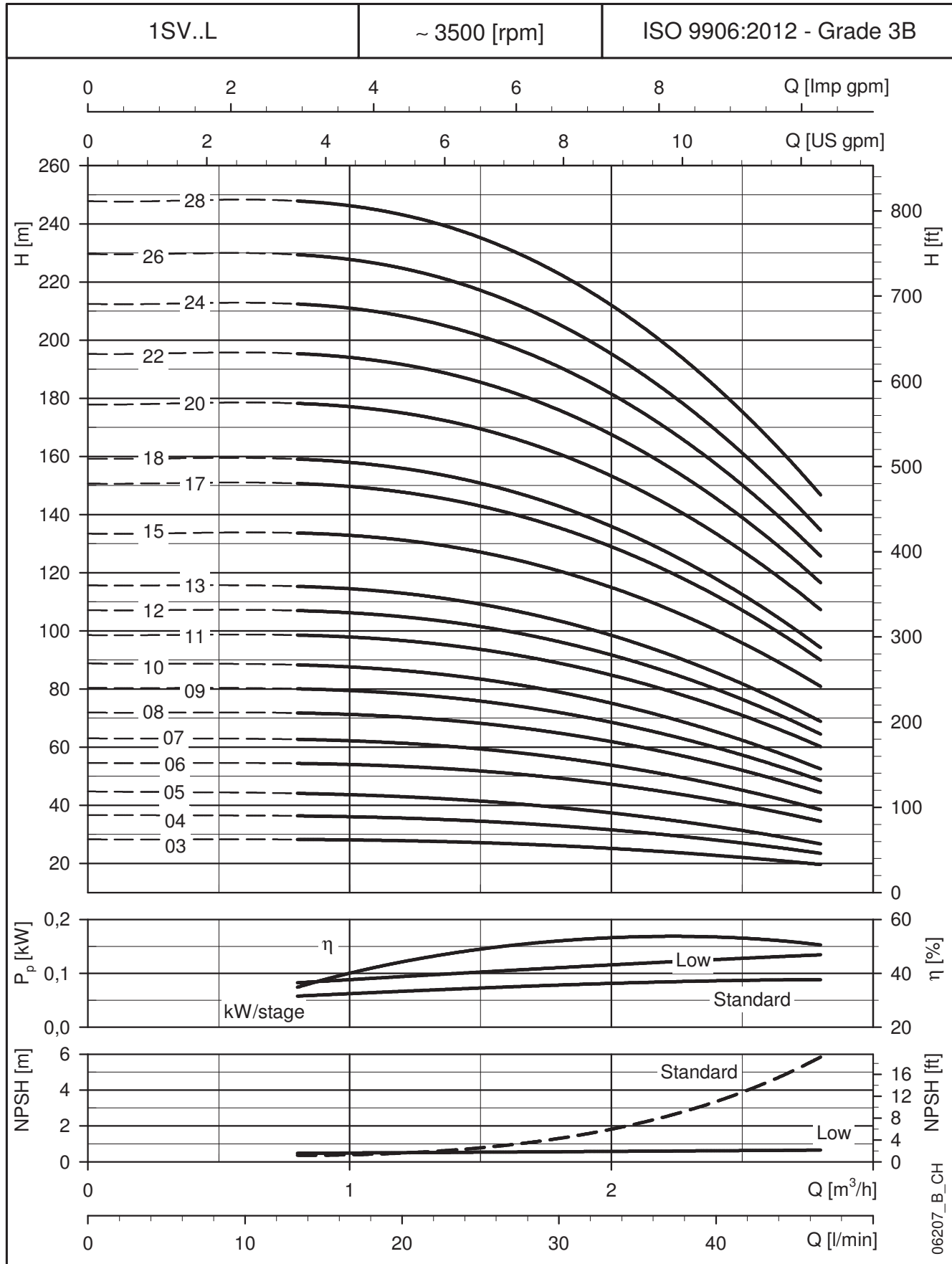

These performances are valid for liquids with density $\rho = 1.0 \text{ Kg/dm}^3$ and kinematic viscosity $\nu = 1 \text{ mm}^2/\text{sec}$.

3SV..L SERIES - LOW NPSH DIMENSIONS AND WEIGHTS AT 60 Hz, 2-POLE

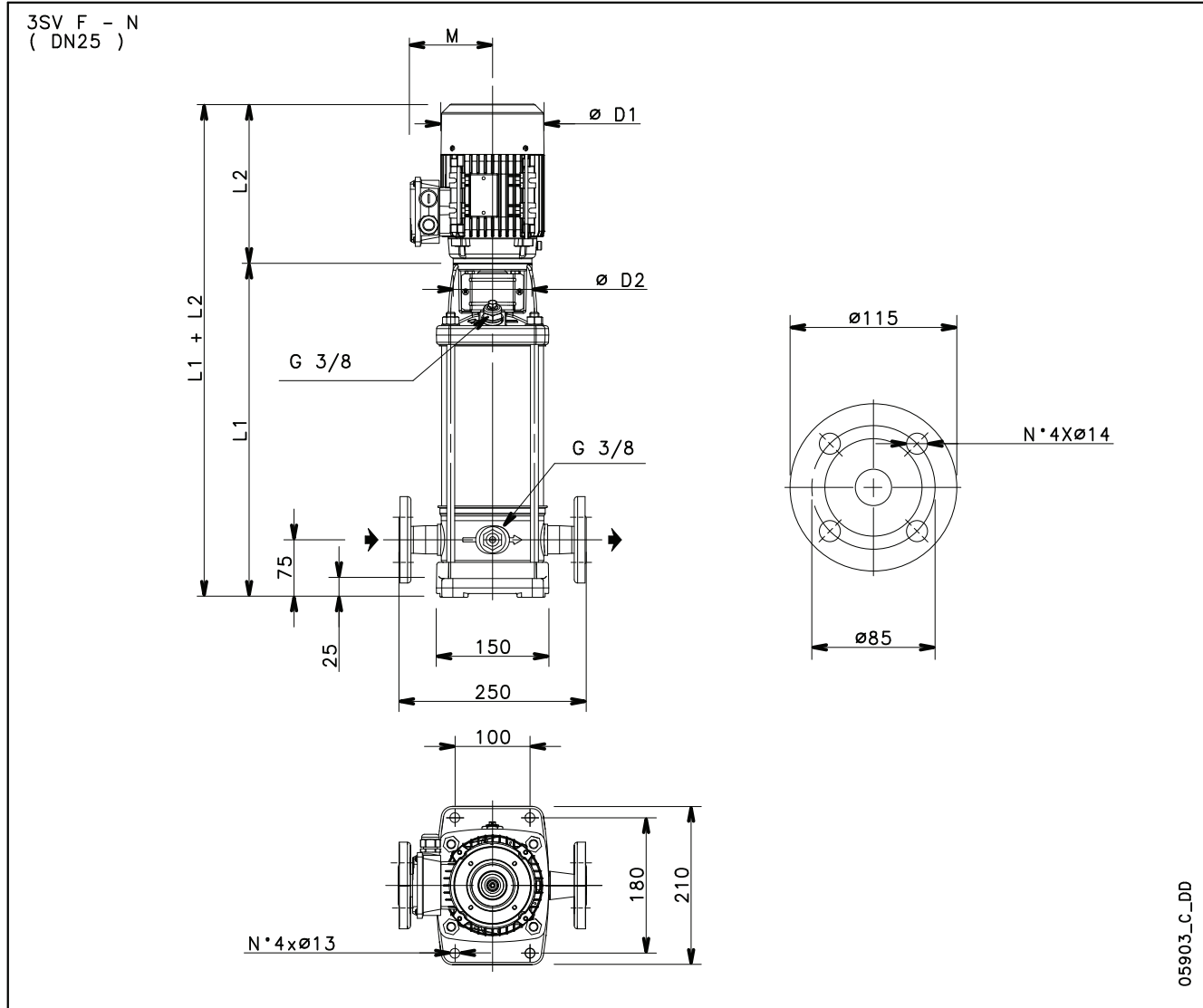

05903_C_DD

PUMP TYPE	MOTOR		DIMENSIONS (mm)								WEIGHT kg	
	kW	SIZE	L1	L2		M		D1		D2	PUMP	ELECTRIC
				1 ~	3 ~	1 ~	3 ~	1 ~	3 ~			
3SV03..L..	0,55	71	278	231	231	121	121	140	140	105	8,5	15,2
3SV04..L../D	0,75	80	308	226	263	121	129	140	155	120	9,3	18,9
3SV05..L../D	1,1	80	328	263	263	137	129	155	155	120	9,7	21,1
3SV06..L../D	1,1	80	348	263	263	137	129	155	155	120	10,1	21,5
3SV07..L../D	1,1	80	368	263	263	137	129	155	155	140	10,5	21,9
3SV08..L../D	1,5	90	398	263	263	137	129	155	155	140	11,2	24,5
3SV09..L../D	1,5	90	418	263	263	137	129	155	155	140	11,6	25
3SV10..L..	2,2	90	438	298	298	151	134	174	174	140	12	30,2
3SV11..L..	2,2	90	458	298	298	151	134	174	174	140	12,4	30,6
3SV12..L..	2,2	90	478	298	298	151	134	174	174	140	12,8	30,9
3SV13..L..	2,2	90	498	298	298	151	134	174	174	140	13,2	31,3
3SV14..L..	2,2	90	518	298	298	151	134	174	174	140	13,6	31,7
3SV15..L..	3	100	548	-	298	-	134	-	174	160	14,4	35,4
3SV17..L..	3	100	588	-	298	-	134	-	174	160	15,2	36,2
3SV19..L..	3	100	628	-	298	-	134	-	174	160	16	37
3SV21..L..	4	112	668	-	319	-	154	-	197	160	16,8	43,2
3SV23..L..	4	112	708	-	319	-	154	-	197	160	17,6	44

**3SV..L SERIES - LOW NPSH
OPERATING CHARACTERISTICS AT 60 Hz, 2-POLE**

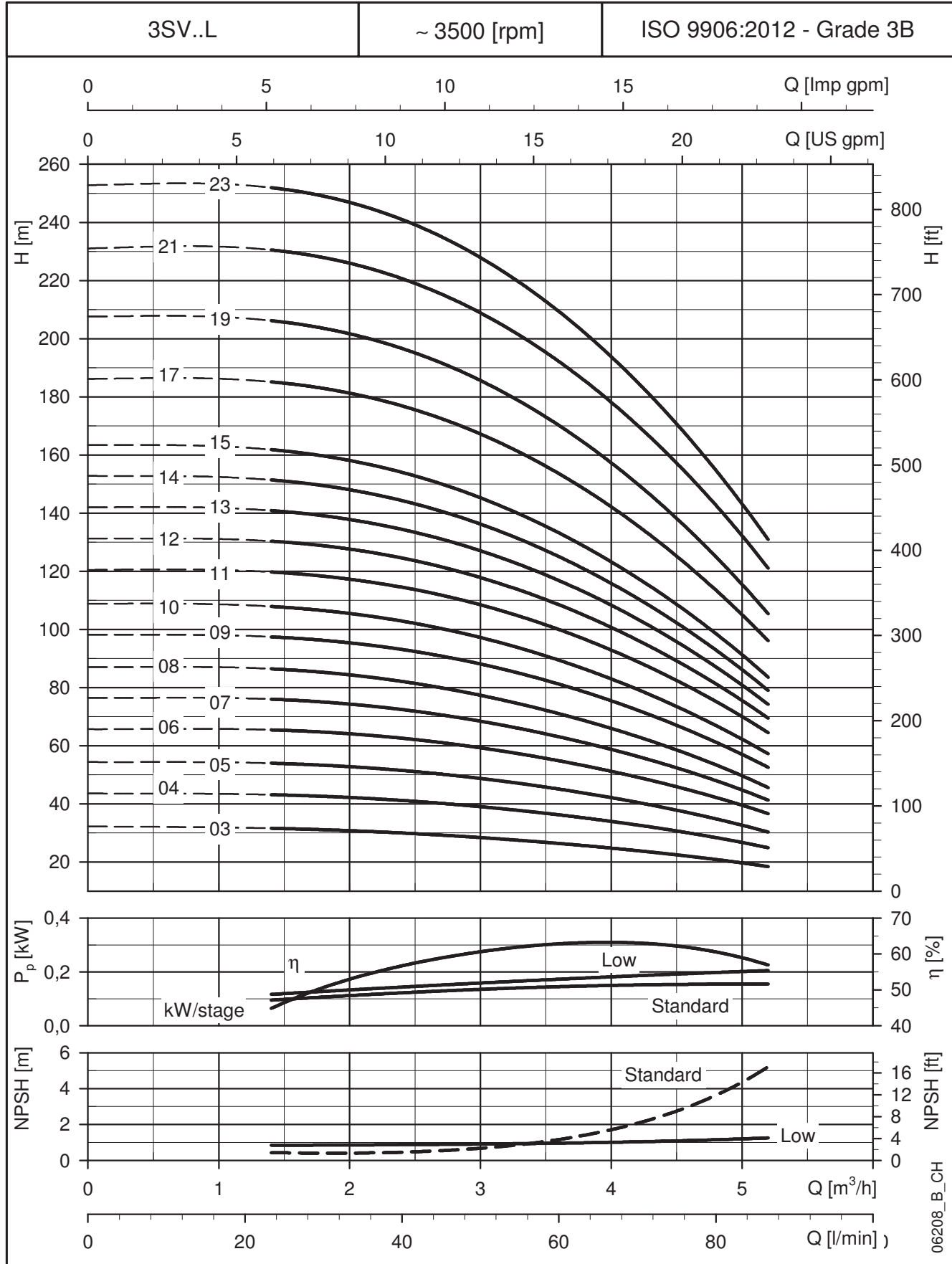

These performances are valid for liquids with density $\rho = 1.0 \text{ Kg/dm}^3$ and kinematic viscosity $\nu = 1 \text{ mm}^2/\text{sec}$.

5SV..L SERIES - LOW NPSH DIMENSIONS AND WEIGHTS AT 60 Hz, 2-POLE

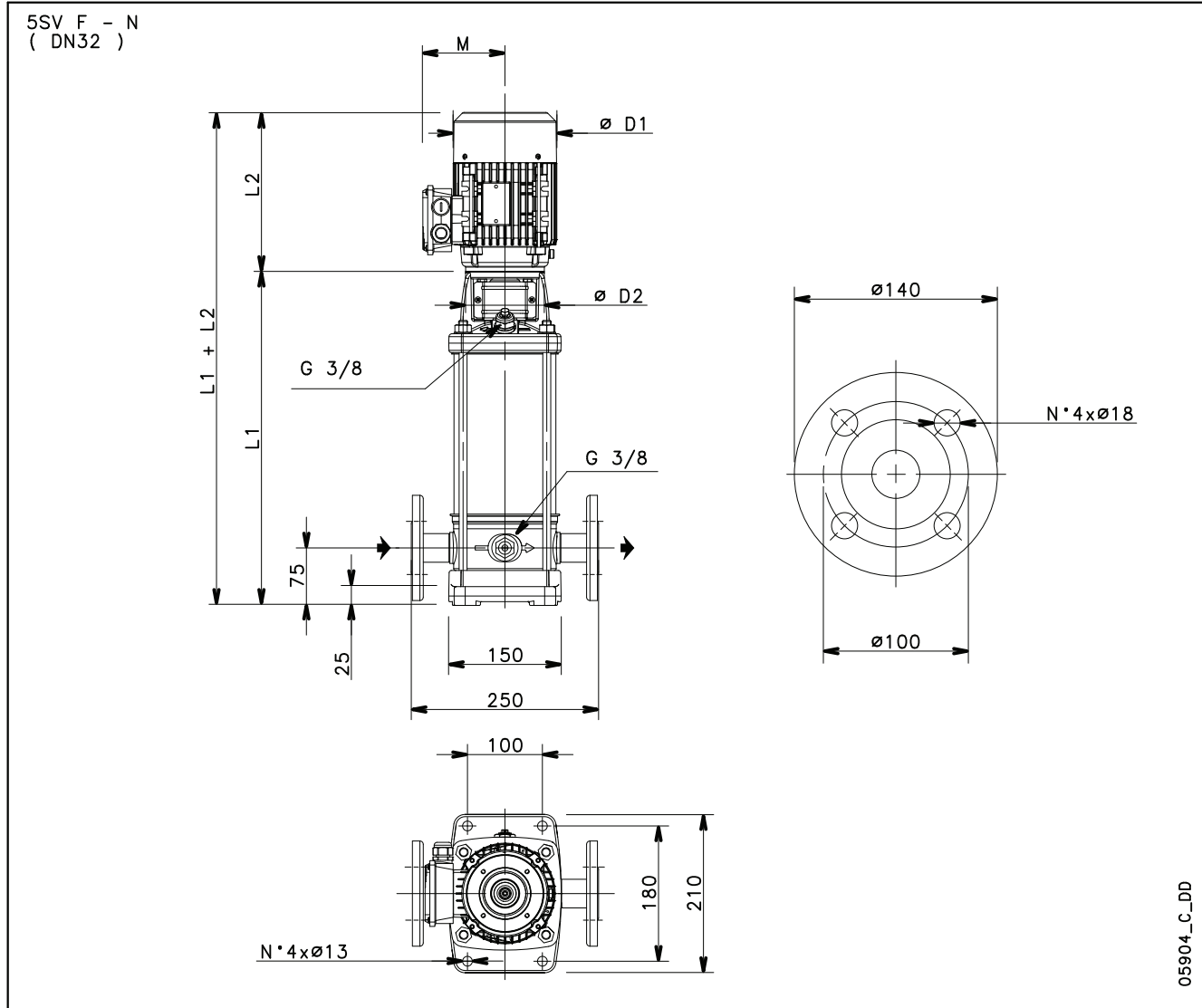

05904_C_DD

PUMP TYPE	MOTOR		DIMENSIONS (mm)								WEIGHT kg	
	kW	SIZE	L1	L2		M		D1		D2	PUMP	ELECTRIC PUMP
5SV03..L./D	1,1	80	303	263	263	137	129	155	155	120	9,4	20,8
5SV04..L./D	1,5	90	338	263	263	137	129	155	155	140	10,1	23,5
5SV05..L./D	1,5	90	363	263	263	137	129	155	155	140	10,6	24
5SV06..L..	2,2	90	388	298	298	151	134	174	174	140	11,1	29,3
5SV07..L..	2,2	90	413	298	298	151	134	174	174	140	11,6	29,8
5SV08..L..	2,2	90	438	298	298	151	134	174	174	140	12,1	30,2
5SV09..L..	3	100	473	-	298	-	134	-	174	160	13	34
5SV10..L..	3	100	498	-	298	-	134	-	174	160	13,5	34,4
5SV11..L..	3	100	523	-	298	-	134	-	174	160	13,9	34,9
5SV12..L..	4	112	548	-	319	-	154	-	197	160	14,4	40,8
5SV13..L..	4	112	573	-	319	-	154	-	197	160	14,9	41,2
5SV14..L..	4	112	598	-	319	-	154	-	197	160	15,3	41,7
5SV15..L..	4	112	623	-	319	-	154	-	197	160	15,8	42,2
5SV16..L..	4	112	648	-	319	-	154	-	197	160	16,3	42,6
5SV17..L..	5,5	132	693	-	375	-	168	-	214	300	20,7	58,2
5SV19..L..	5,5	132	743	-	375	-	168	-	214	300	21,6	59,2
5SV21..L..	5,5	132	793	-	375	-	168	-	214	300	22,6	60,1
5SV23..L..	7,5	132	843	-	367	-	191	-	256	300	23	79

**5SV..L SERIES - LOW NPSH
OPERATING CHARACTERISTICS AT 60 Hz, 2-POLE**

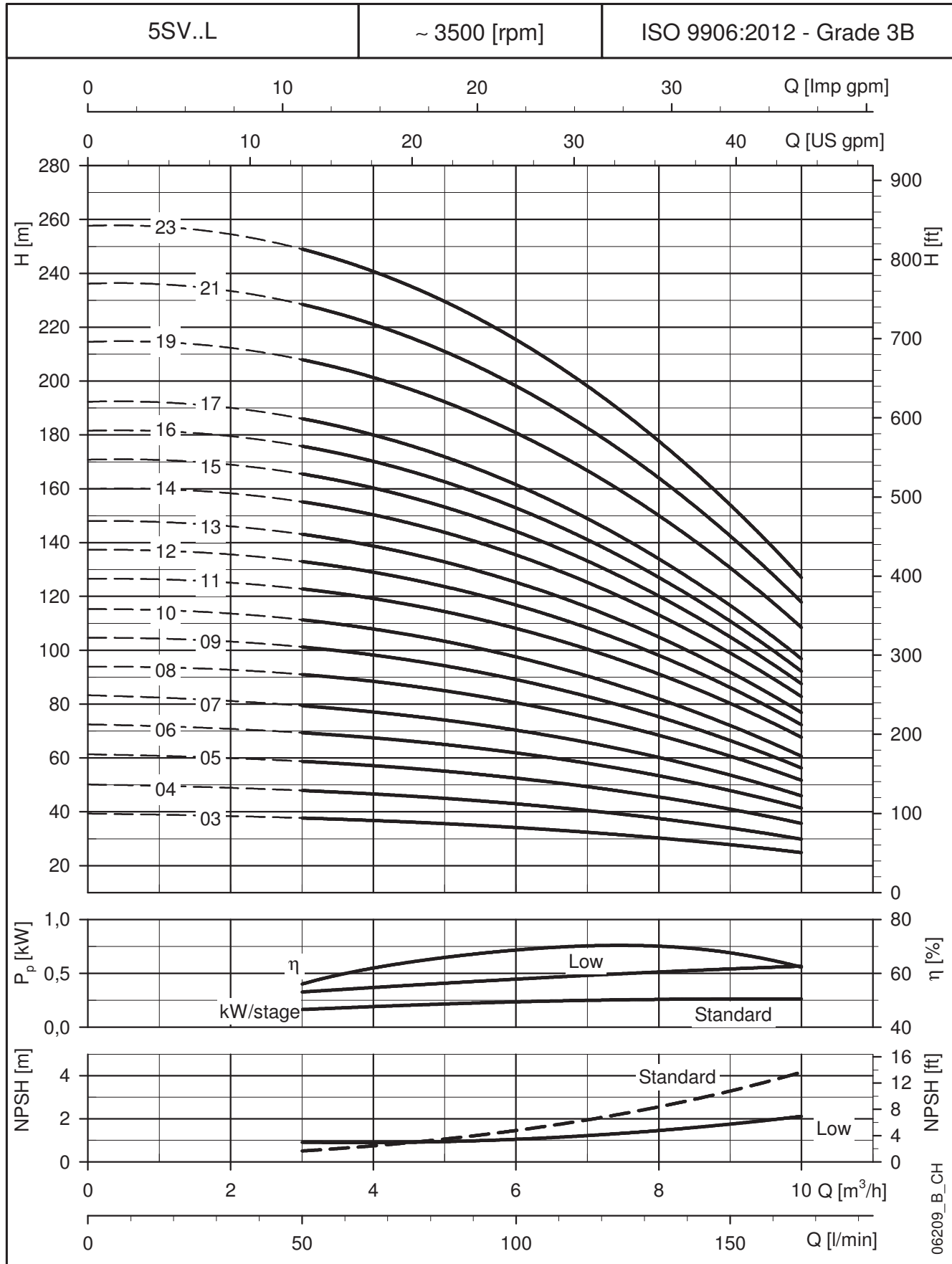

These performances are valid for liquids with density $\rho = 1.0 \text{ Kg/dm}^3$ and kinematic viscosity $\nu = 1 \text{ mm}^2/\text{sec}$.

10SV..L SERIES - LOW NPSH DIMENSIONS AND WEIGHTS AT 60 Hz, 2-POLE

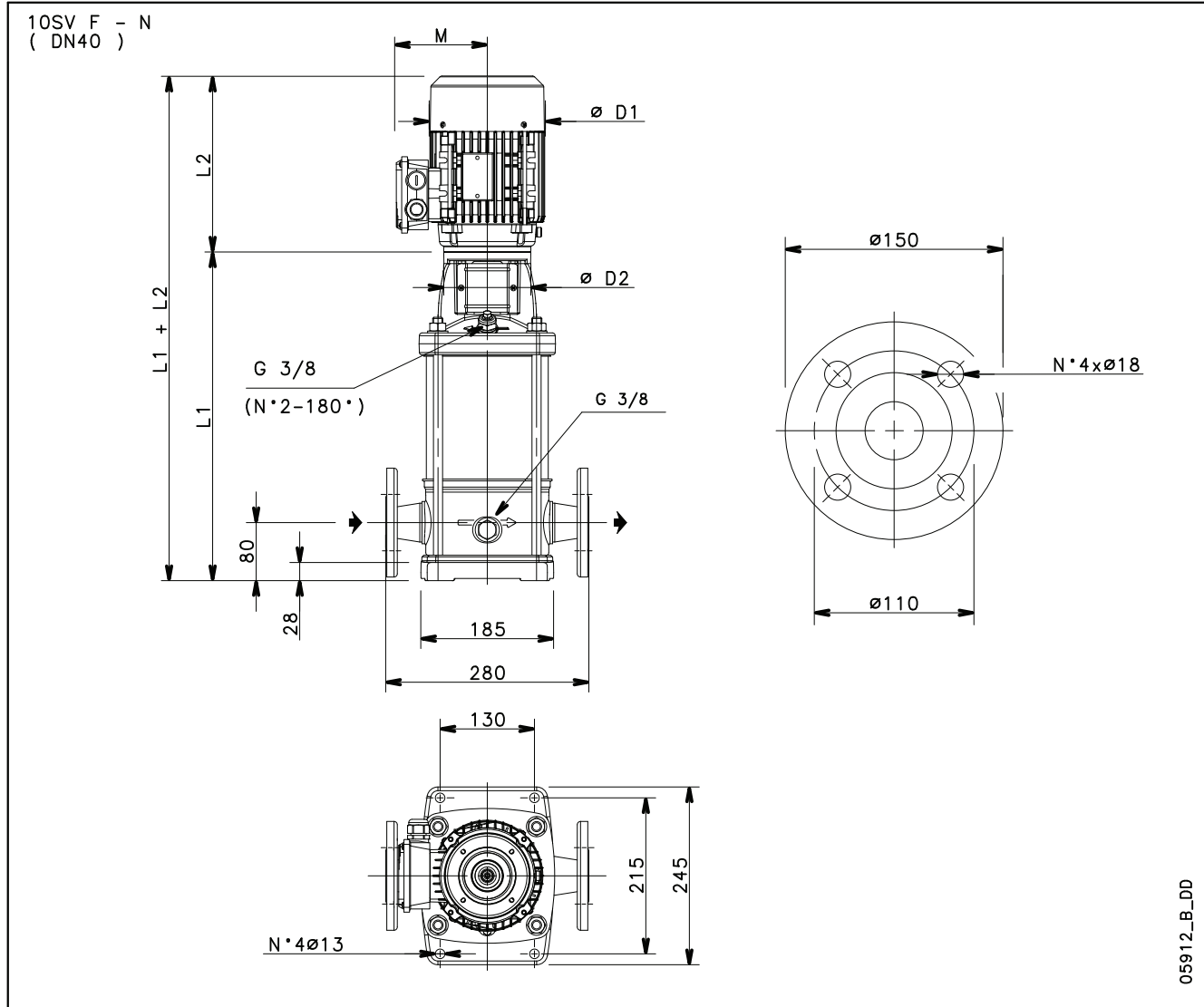

05912_B_DD

PUMP TYPE	MOTOR		DIMENSIONS (mm)								WEIGHT kg	
	kW	SIZE	L1	L2		M		D1		D2	PUMP	ELECTRIC
				1 ~	3 ~	1 ~	3 ~	1 ~	3 ~			
10SV03..L..	3	100	409	-	298	-	134	-	174	160	17,5	38,5
10SV04..L..	3	100	441	-	298	-	134	-	174	160	18,4	39,4
10SV05..L..	4	112	473	-	319	-	154	-	197	160	19,3	45,7
10SV06..L..	5,5	132	572	-	375	-	214	-	214	300	25	62,6
10SV07..L..	5,5	132	604	-	375	-	168	-	214	300	26	63,5
10SV08..L..	5,5	132	636	-	375	-	168	-	214	300	26,9	64,5
10SV09..L..	7,5	132	668	-	367	-	191	-	256	300	27,9	83,6
10SV10..L..	7,5	132	700	-	367	-	191	-	256	300	28,8	84,5
10SV11..L..	7,5	132	732	-	367	-	191	-	256	300	29,7	85,5
10SV13..L..	11	160	826	-	428	-	191	-	256	350	34,4	105
10SV15..L..	11	160	890	-	428	-	191	-	256	350	36,3	107

10sv-L-2p60-en_c_td

**10SV..L SERIES - LOW NPSH
OPERATING CHARACTERISTICS AT 60 Hz, 2-POLE**

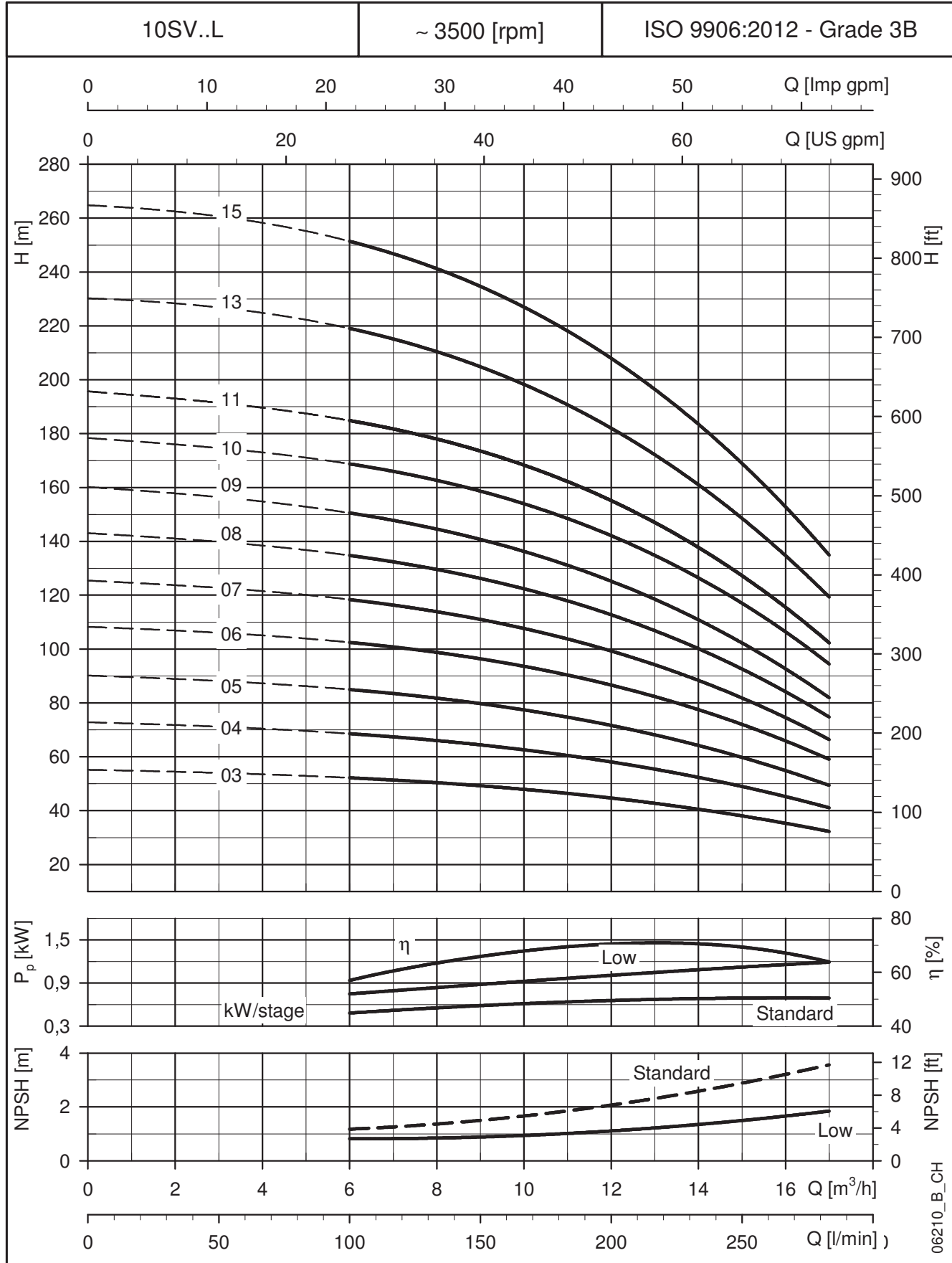

These performances are valid for liquids with density $\rho = 1.0 \text{ Kg/dm}^3$ and kinematic viscosity $\nu = 1 \text{ mm}^2/\text{sec}$.

**15SV..L SERIES - LOW NPSH
DIMENSIONS AND WEIGHTS AT 60 Hz, 2-POLE**

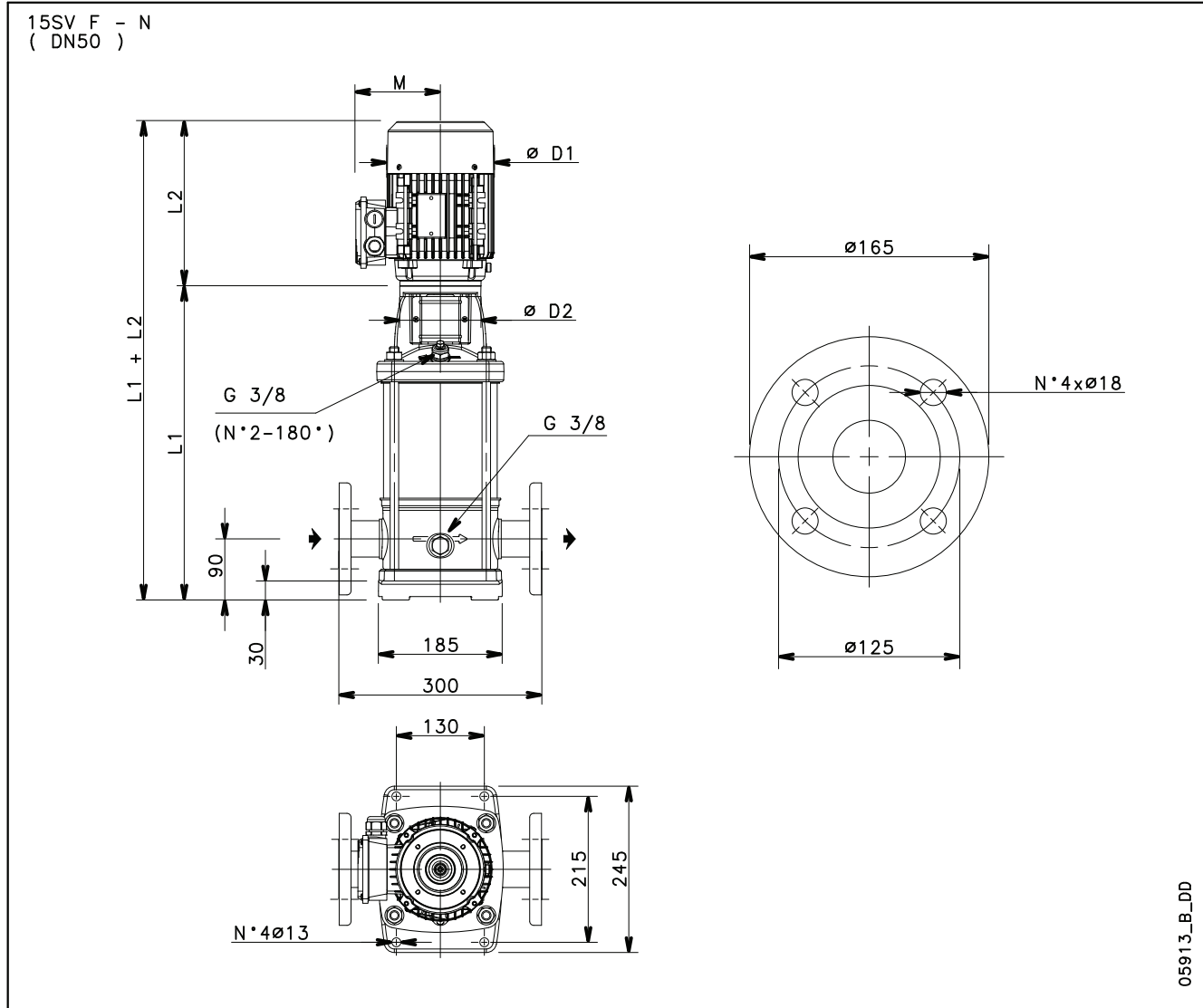

PUMP TYPE	MOTOR		DIMENSIONS (mm)					WEIGHT kg	
	kW	SIZE	L1	L2	M	D1	D2	PUMP	ELECTRIC PUMP
15SV02..L..	4	112	419	319	154	174	160	18	44,4
15SV03..L..	5,5	132	534	375	168	214	300	24	61,6
15SV04..L..	7,5	132	582	367	191	256	300	25,2	81
15SV05..L..	11	160	660	428	191	256	350	29,3	100
15SV06..L..	11	160	708	428	191	256	350	30,6	101
15SV07..L..	11	160	756	428	191	256	350	32	103
15SV08..L..	15	160	804	494	240	313	350	33,3	136
15SV09..L..	15	160	852	494	240	313	350	34,6	137
15SV10..L..	15	160	900	494	240	313	350	36	138
15SV11..L..	18,5	160	948	494	240	313	350	37,3	148
15SV12..L..	18,5	160	996	494	240	313	350	38,6	150

**15SV..L SERIES - LOW NPSH
OPERATING CHARACTERISTICS AT 60 Hz, 2-POLE**

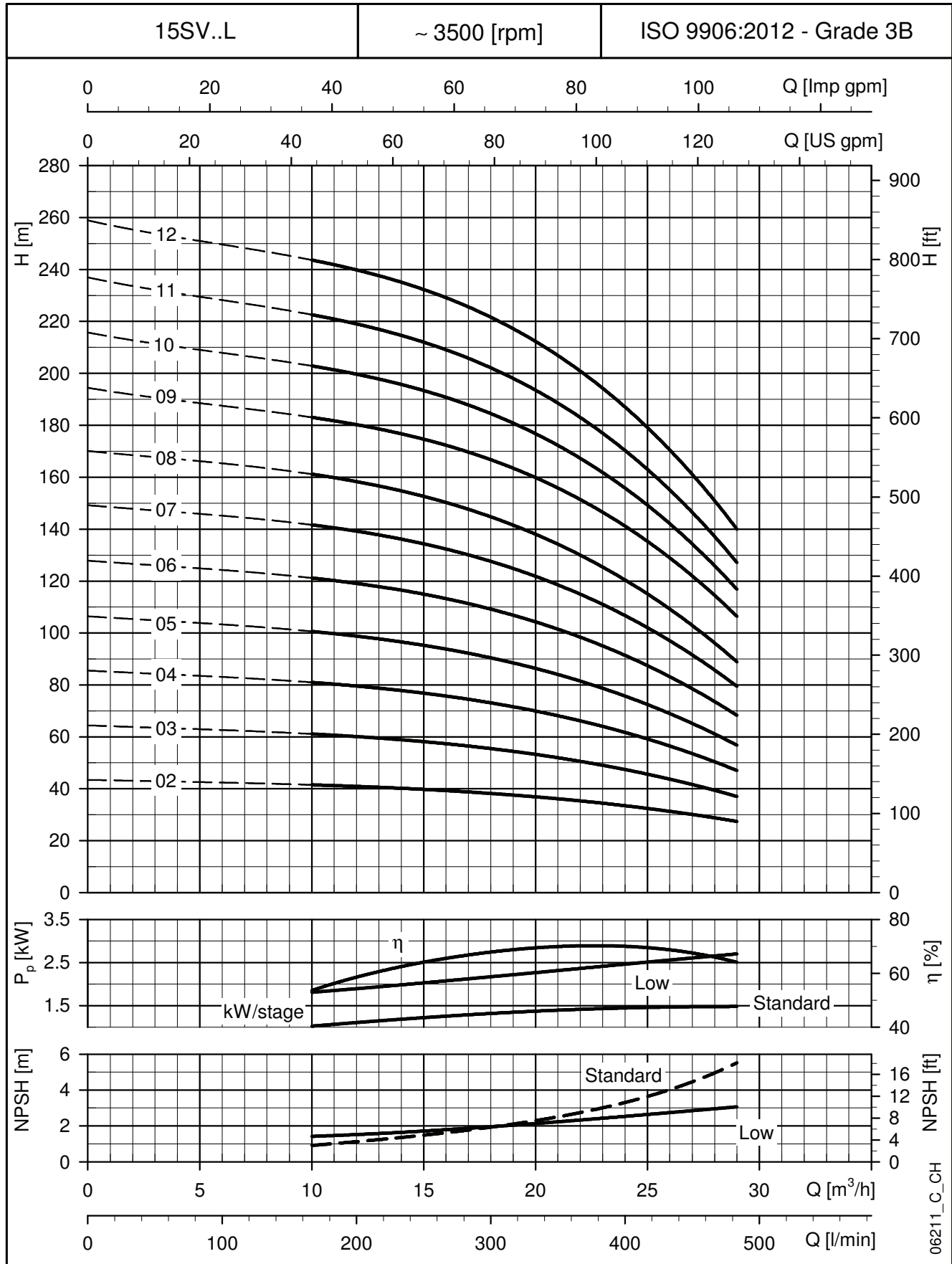

These performances are valid for liquids with density $\rho = 1.0 \text{ Kg/dm}^3$ and kinematic viscosity $\nu = 1 \text{ mm}^2/\text{sec}$.

22SV..L SERIES - LOW NPSH DIMENSIONS AND WEIGHTS AT 60 Hz, 2-POLE

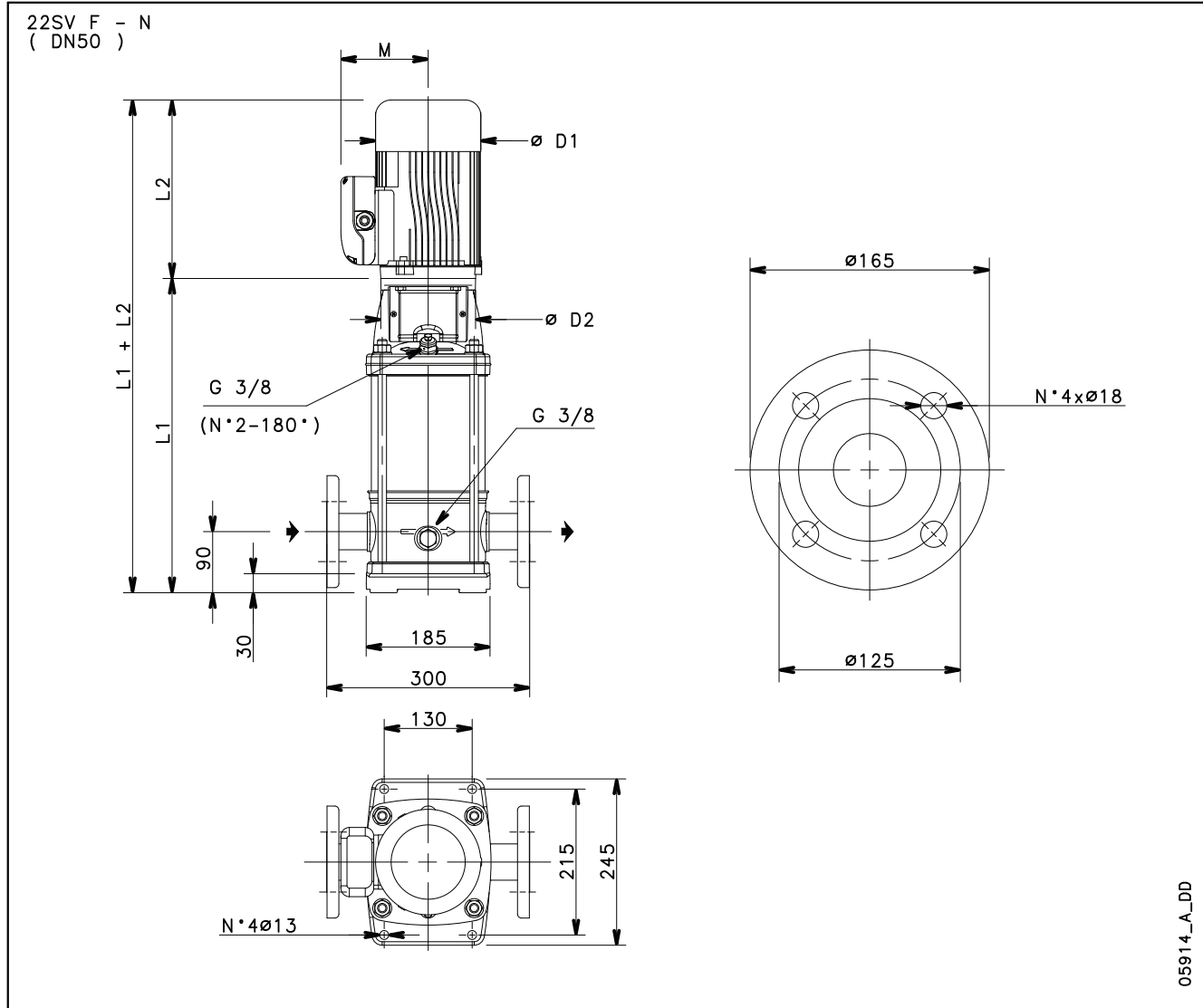

PUMP TYPE	MOTOR		DIMENSIONS (mm)					WEIGHT kg	
	kW	SIZE	L1	L2	M	D1	D2	PUMP	ELECTRIC PUMP
22SV02..L..	5,5	132	486	375	168	214	300	23	61
22SV03..L..	7,5	132	534	367	191	256	300	24,3	80
22SV04..L..	11	160	612	428	191	256	350	28,5	99
22SV05..L..	11	160	660	428	191	256	350	29,8	100
22SV06..L..	15	160	708	494	240	313	350	31,1	133
22SV07..L..	15	160	756	494	240	313	350	32,4	135
22SV08..L..	15	160	804	494	240	313	350	33,8	136
22SV09..L..	18,5	160	852	494	240	313	350	35,1	146
22SV10..L..	22	180	900	494	240	313	350	36,4	158

**22SV..L SERIES - LOW NPSH
OPERATING CHARACTERISTICS AT 60 Hz, 2-POLE**

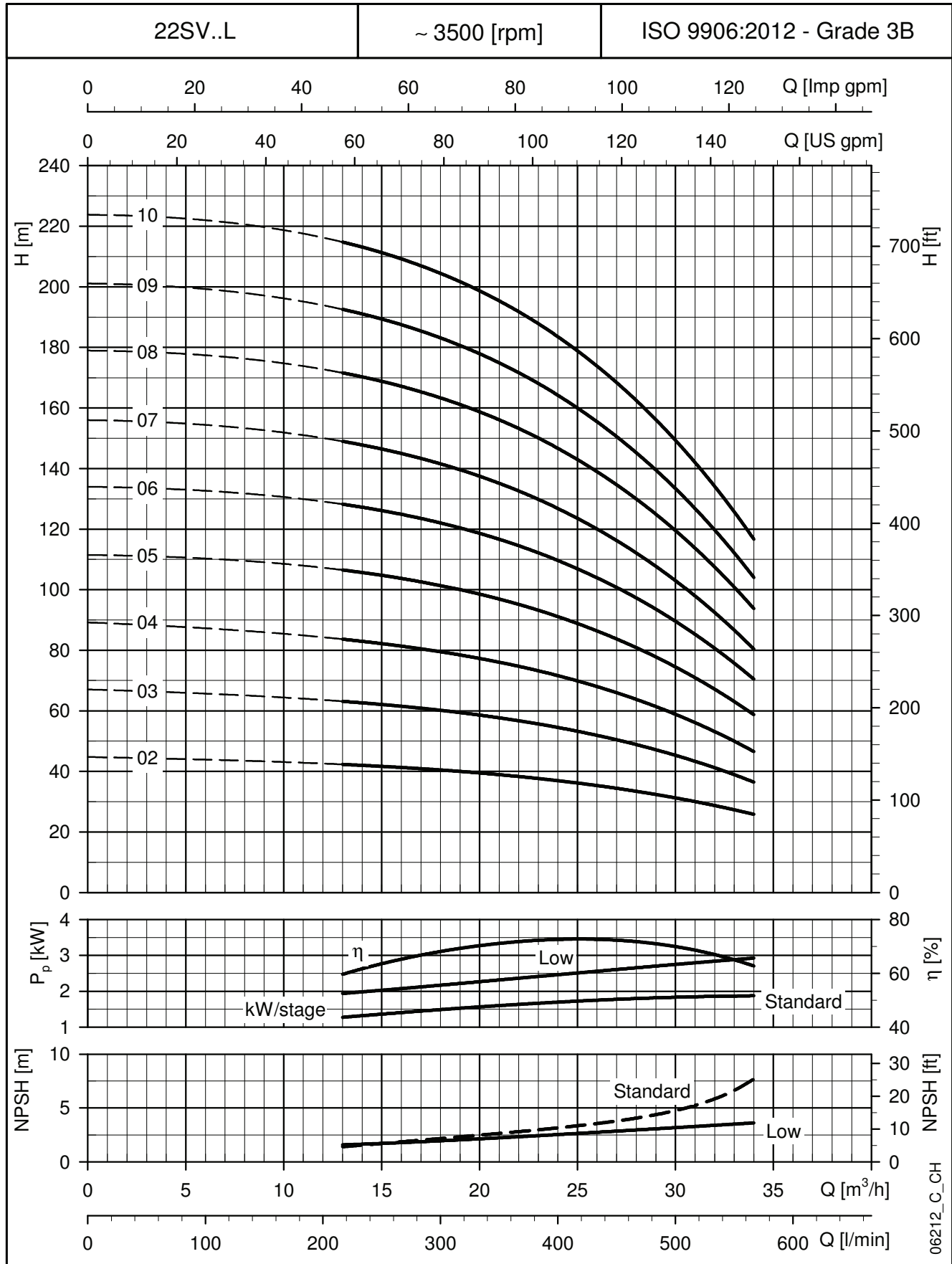

These performances are valid for liquids with density $\rho = 1.0 \text{ Kg/dm}^3$ and kinematic viscosity $\nu = 1 \text{ mm}^2/\text{sec}$.

33SV..L SERIES - LOW NPSH DIMENSIONS AND WEIGHTS AT 60 Hz, 2-POLE

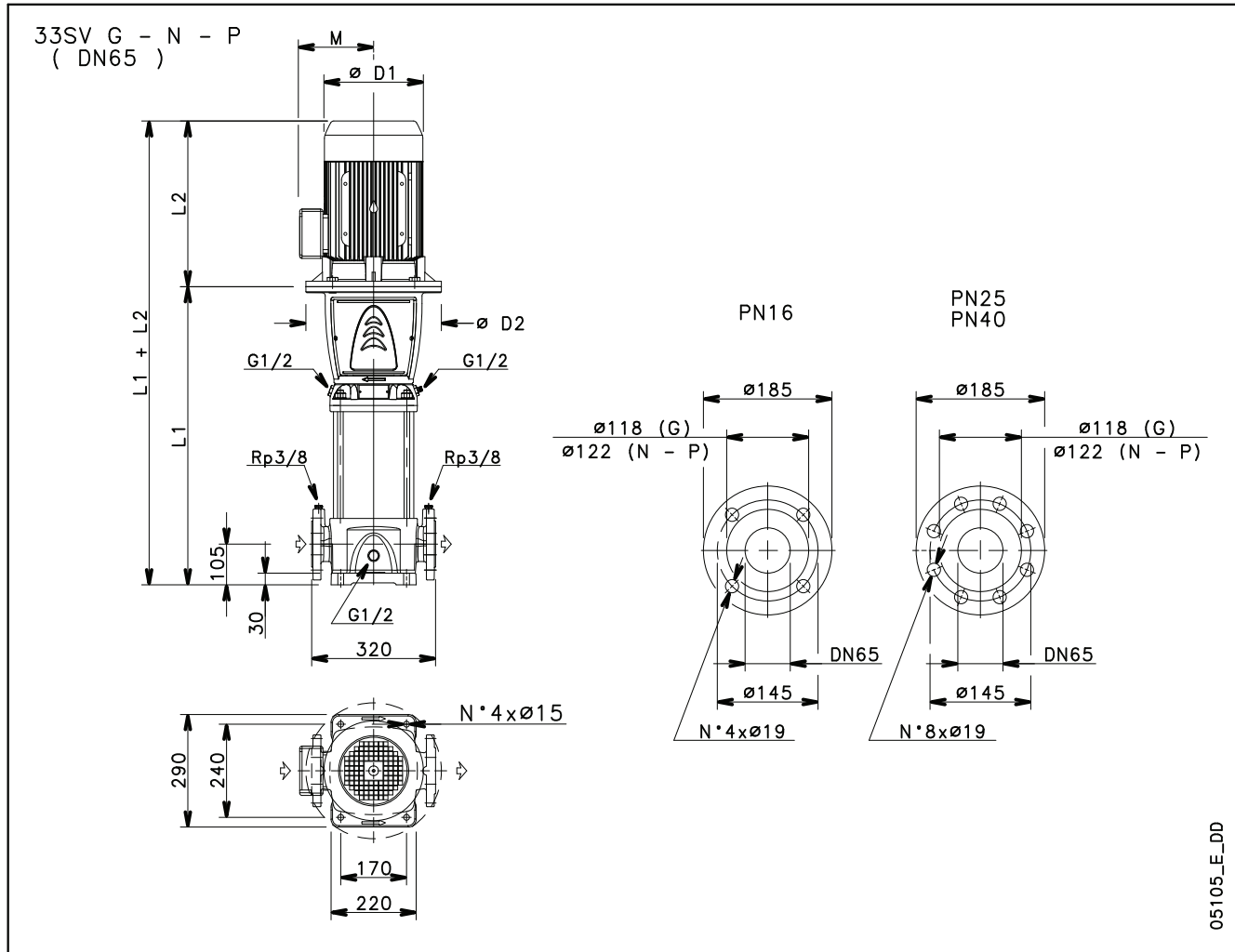

PUMP TYPE	MOTOR		DIMENSIONS (mm)						WEIGHT kg	
	kW	SIZE	L1	L2	D1	D2	M	PN	PUMP	ELECTRIC PUMP
33SV2/1A..L..	7,5	132	584	367	256	300	191	16	61	117
33SV2..L..	11	160	619	428	256	350	191	16	65	136
33SV3/2A..L..	11,0	160	694	428	256	350	191	16	69	140
33SV3/1A..L..	15	160	694	494	313	350	240	16	69	171
33SV3..L..	15	160	694	494	313	350	240	16	69	171
33SV4/2A..L..	15	160	769	494	313	350	240	16	73	175
33SV4/1A..L..	18,5	160	769	494	313	350	240	25	73	184
33SV4..L..	18,5	160	769	494	313	350	240	25	73	184
33SV5/2A..L..	18,5	160	844	494	313	350	240	25	77	188
33SV5/1A..L..	22	180	844	494	313	350	240	25	78	200
33SV5..L..	22	180	844	494	313	350	240	25	78	200
33SV6/2A..L..	30	200	919	671	408	400	285	25	89	304
33SV6/1A..L..	30	200	919	671	408	400	285	25	89	297
33SV6..L..	30	200	919	671	408	400	285	25	89	297
33SV7/2A..L..	30	200	994	671	408	400	285	25	92	300
33SV7/1A..L..	30	200	994	671	408	400	285	25	92	300
33SV7..L..	30	200	994	671	408	400	285	25	92	300
33SV8/2A..L..	37	200	1069	671	408	400	285	40	101	325
33SV8/1A..L..	37	200	1069	671	408	400	285	40	101	325
33SV8..L..	37	200	1069	671	408	400	285	40	101	325

**33SV..L SERIES - LOW NPSH
OPERATING CHARACTERISTICS AT 60 Hz, 2-POLE**

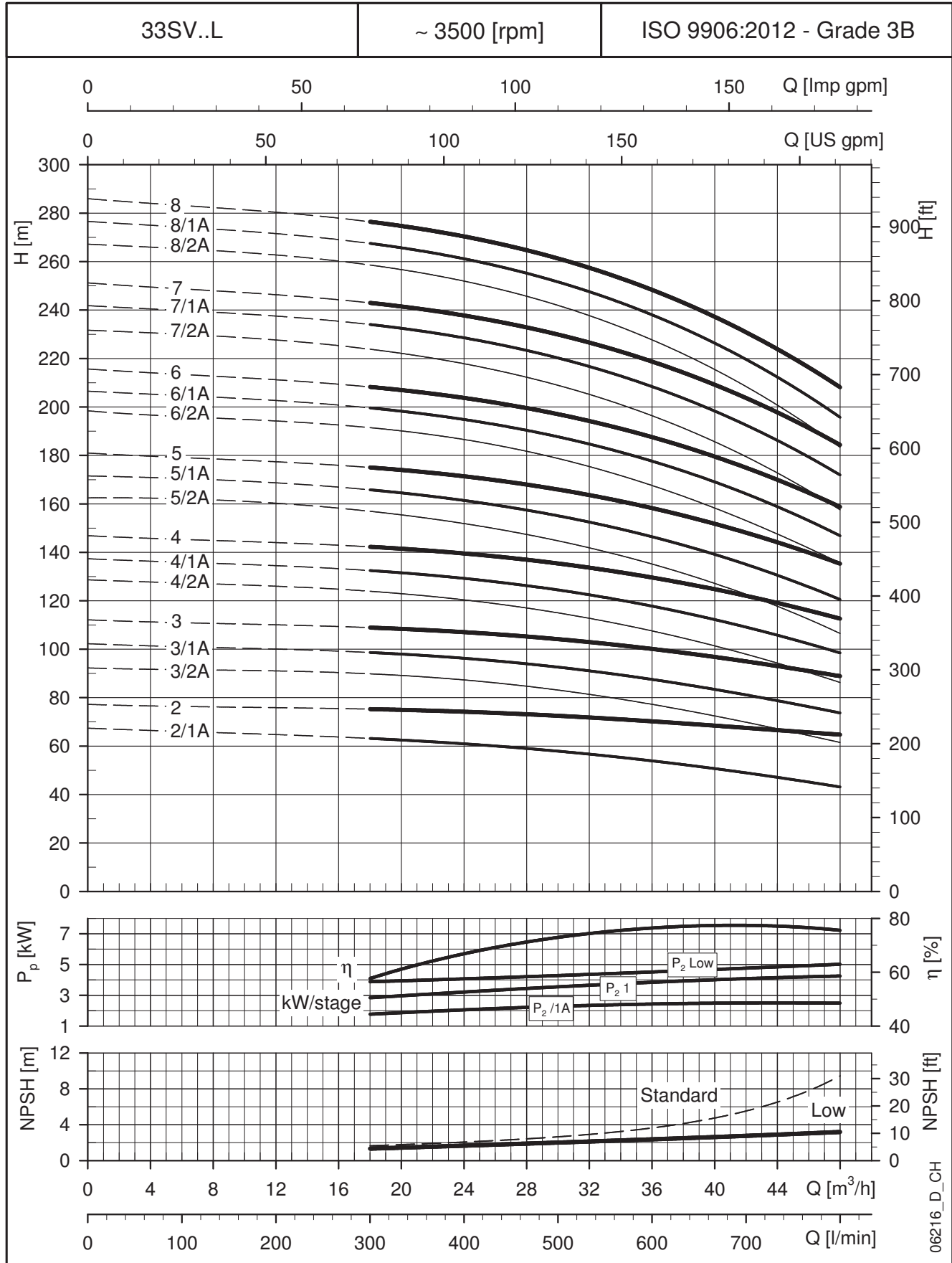

These performances are valid for liquids with density $\rho = 1.0 \text{ Kg/dm}^3$ and kinematic viscosity $\nu = 1 \text{ mm}^2/\text{sec}$.

46SV..L SERIES - LOW NPSH DIMENSIONS AND WEIGHTS AT 60 Hz, 2-POLE

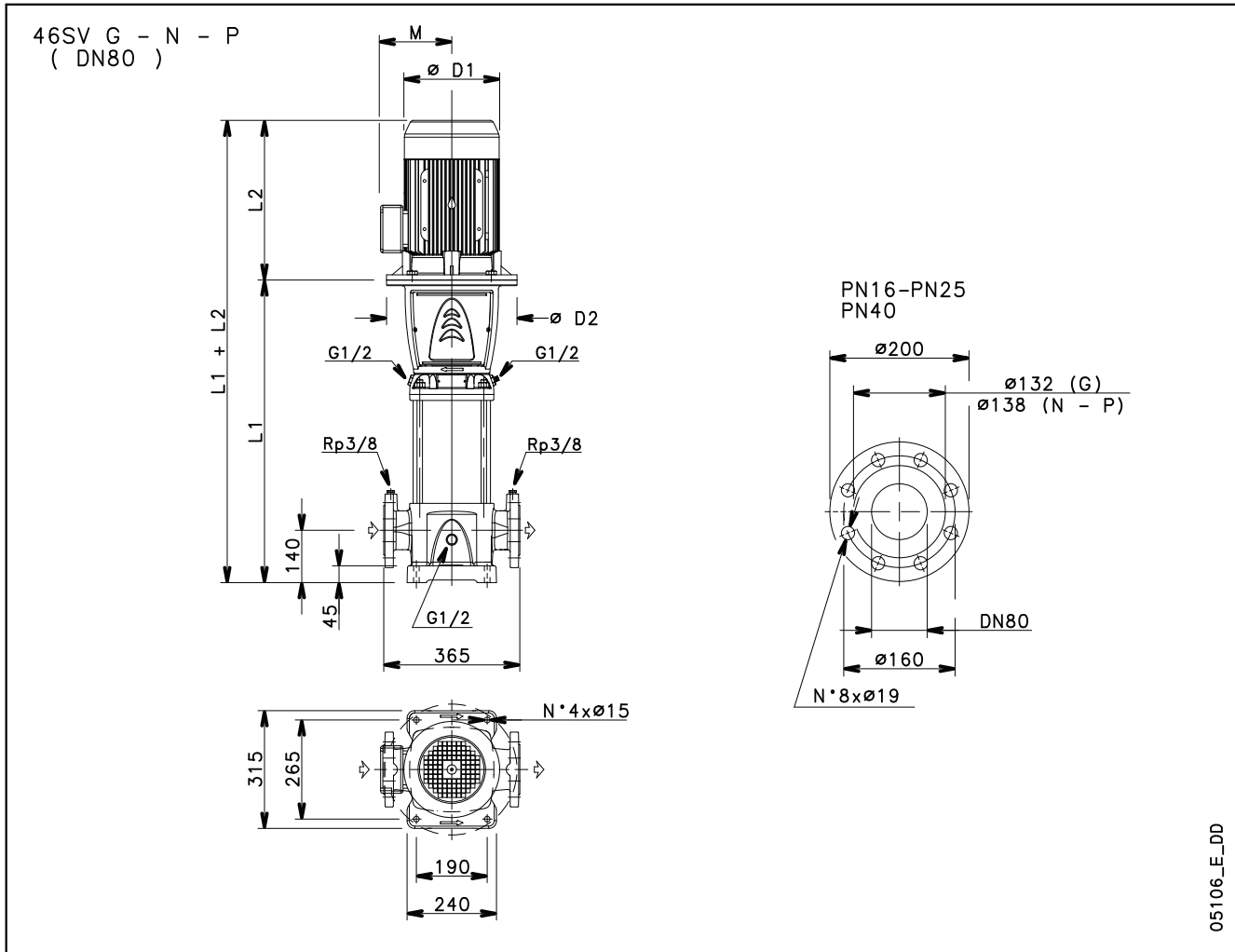

PUMP TYPE	MOTOR		DIMENSIONS (mm)						WEIGHT kg	
	kW	SIZE	L1	L2	D1	D2	M	PN	PUMP	ELECTRIC PUMP
46SV2/1A..L..	15	160	659	494	313	350	240	16	70	172
46SV2..L..	15	160	659	494	313	350	240	16	70	172
46SV3/2A..L..	18,5	160	734	494	313	350	240	16	74	185
46SV3/1A..L..	22	180	734	494	313	350	240	16	74	196
46SV3..L..	22	180	734	494	313	350	240	16	74	196
46SV4/2A..L..	30	200	809	671	408	400	285	16	86	294
46SV4/1A..L..	30	200	809	671	408	400	285	16	86	294
46SV4..L..	30	200	809	671	408	400	285	16	86	294
46SV5/2A..L..	30	200	884	671	408	400	285	25	90	298
46SV5/1A..L..	37	200	884	671	408	400	285	25	90	314
46SV5..L..	37	200	884	671	408	400	285	25	90	314
46SV6/2A..L..	37	200	959	671	408	400	285	25	94	318
46SV6/1A..L..	45	225	959	701	460	400	309	25	98	390
46SV6..L..	45	225	959	701	460	400	309	25	98	390
46SV7/2A..L..	45	225	1034	701	460	450	309	40	105	397
46SV7/1A..L..	45	225	1034	701	460	450	309	40	105	397
46SV7..L..	45	225	1034	701	460	450	309	40	105	397

**46SV..L SERIES - LOW NPSH
OPERATING CHARACTERISTICS AT 60 Hz, 2-POLE**

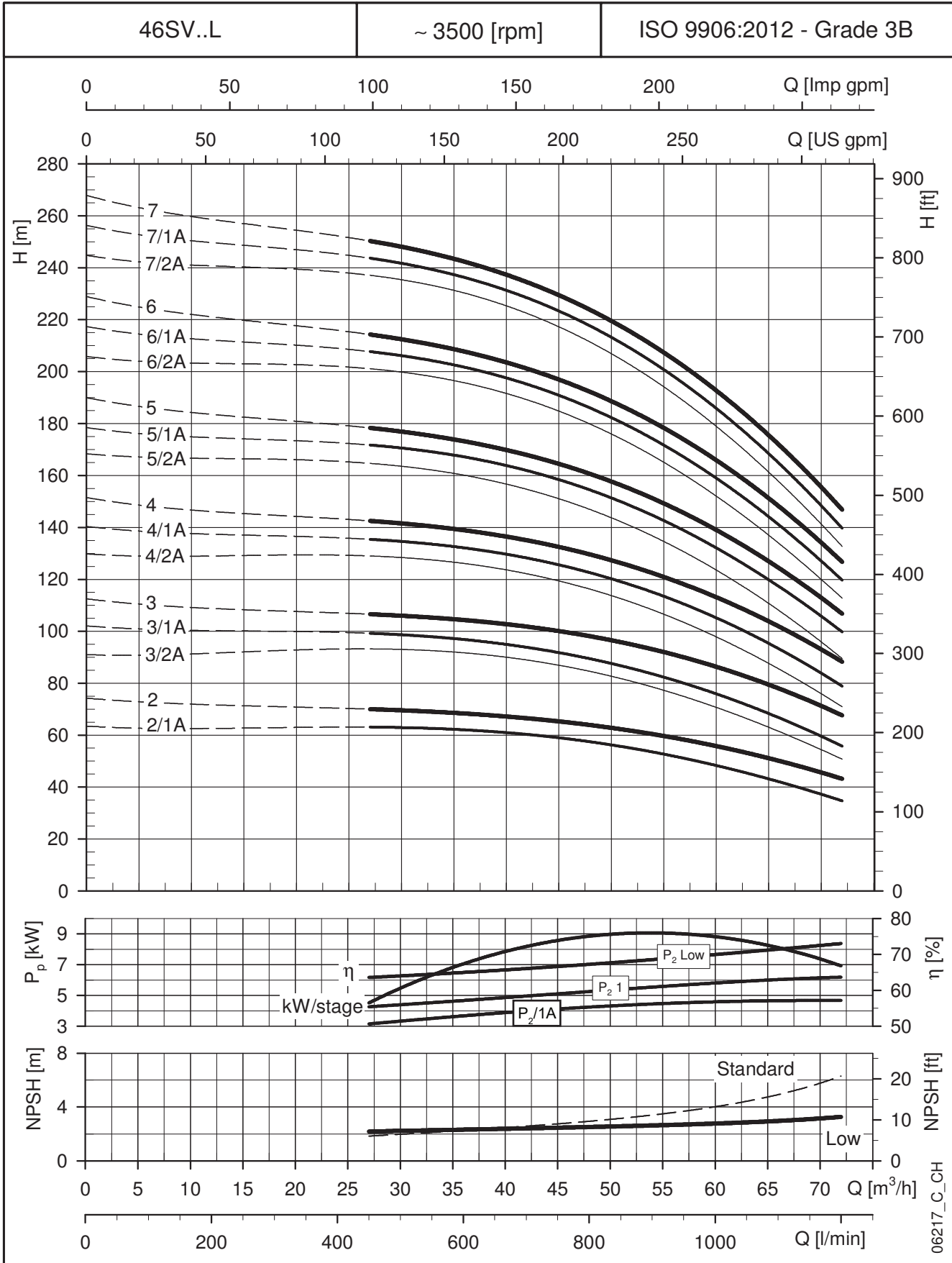

These performances are valid for liquids with density $\rho = 1.0 \text{ Kg/dm}^3$ and kinematic viscosity $\nu = 1 \text{ mm}^2/\text{sec}$.

**66SV..L SERIES - LOW NPSH
DIMENSIONS AND WEIGHTS AT 60 Hz, 2-POLE**

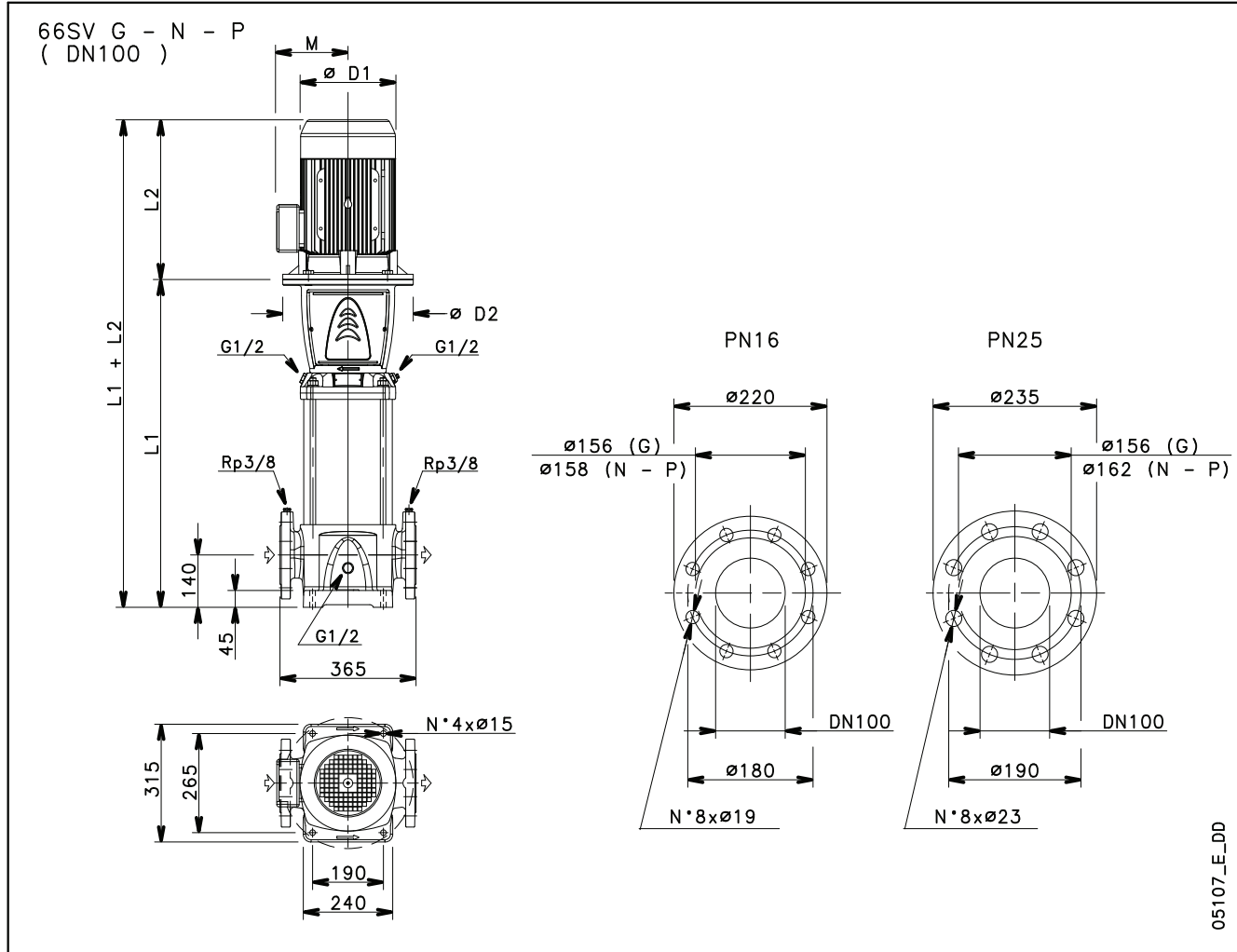

PUMP TYPE	MOTOR		DIMENSIONS (mm)						WEIGHT kg	
	kW	SIZE	L1	L2	D1	D2	M	PN	PUMP	ELECTRIC PUMP
66SV2/1A..L..	18,5	160	699	494	313	350	240	16	81	192
66SV2..L..	22	160	699	494	313	350	240	16	81	203
66SV3/2A..L..	30	200	789	671	408	400	285	16	94	302
66SV3/1A..L..	30	200	789	671	408	400	285	16	94	302
66SV3..L..	37	200	789	671	408	400	285	16	94	318
66SV4/2A..L..	37	200	879	671	408	400	285	16	100	324
66SV4/1A..L..	37	200	879	671	408	400	285	25	102	326
66SV4..L..	45	225	879	701	460	450	309	25	106	398
66SV5/2A..L..	45	225	969	701	460	450	309	25	111	403

**66SV..L SERIES - LOW NPSH
OPERATING CHARACTERISTICS AT 60 Hz, 2-POLE**

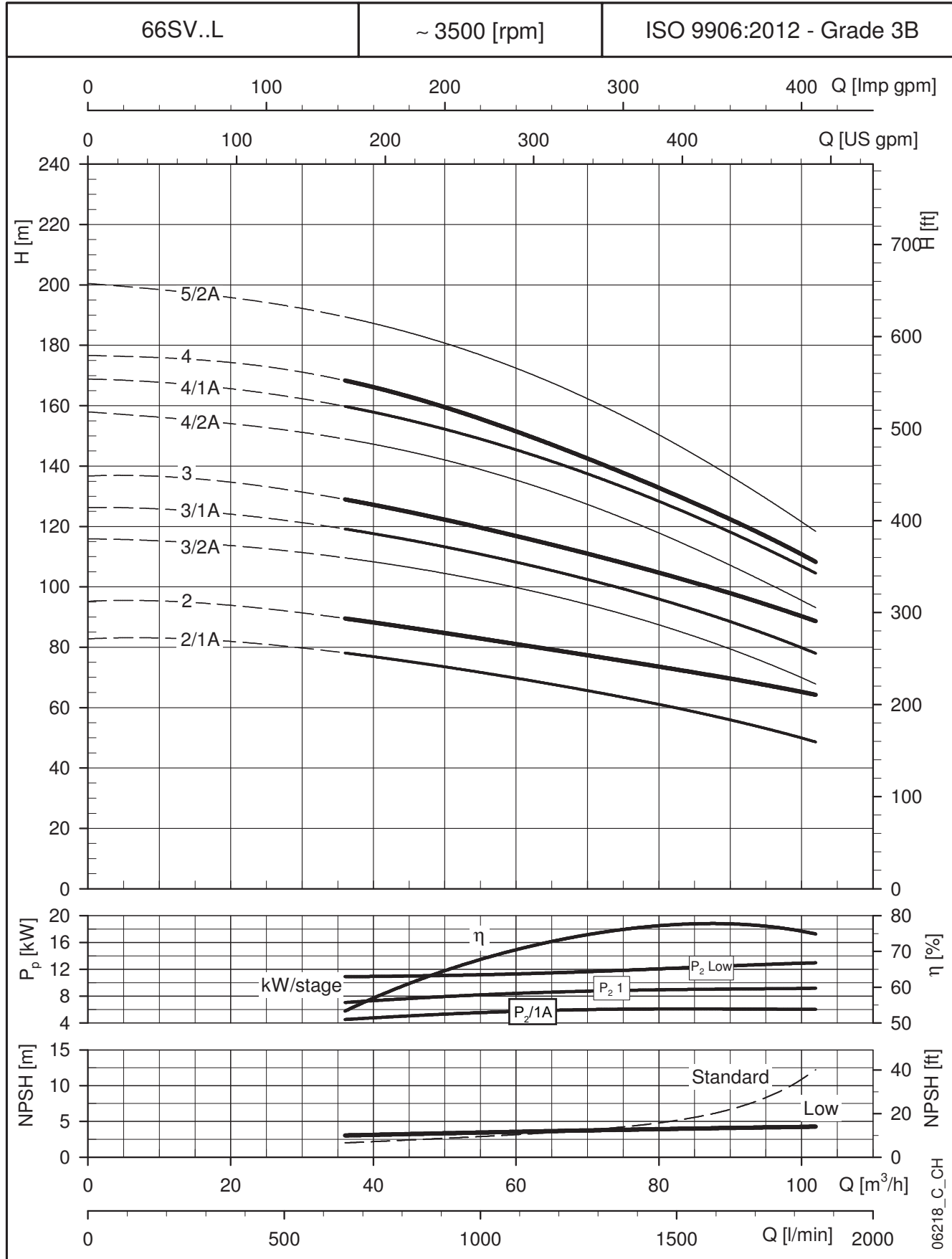

These performances are valid for liquids with density $\rho = 1.0 \text{ Kg/dm}^3$ and kinematic viscosity $\nu = 1 \text{ mm}^2/\text{sec}$.

**HIGH
TEMPERATURE
...150°C
(50/60 Hz)**

e-SV SERIES - HIGH TEMPERATURE (...150°C) 50/60 Hz

Background and context

In industrial applications pumps often have to deal with liquids at high temperatures in order to optimise performance for each production process. In these applications, pumps frequently need to be protected from excessive temperatures for the purpose of maintaining high performance levels. That's why Lowara has developed the e-SV High Temperature series: this sturdy pump integrates a mechanical seal normalised with suitable materials for pumping liquids at high temperatures.

Benefits of the e-SV High Temperature 150°C series

Long-term mechanical seal performance:

Thanks to the special design of its housing, the seal is protected from the stress caused by high temperatures by means of a "natural" lubrication process which is triggered by the pumped liquid itself. Furthermore, the balanced mechanical seal and the high quality of the elastomers used in the e-SV High Temperature series assure excellent long-term performance, even in the harshest operating conditions.

Solidity: e-SV High Temperature pumps are hard-wearing thanks to the hard metal bush supports which can withstand high temperature applications up to 150°C and pressure values up to 25 bar (see the pressure-temperature diagram).

Easy and cost-effective maintenance:

the mechanical seal installed in e-SV High Temperature pumps is a standard balanced mechanical seal (EN12756) which makes it cheap and easy to replace.

Identification code

e-SV High Temperature models are identified by the letter "H" in the standard identification code of the e-SV product range.

Available in the following versions:

FH in AISI 304 (for 1-22SV).

GH in AISI 304/Cast iron (for 33-125SV).

NH in AISI 316 (for all versions).

Example: 3SV13**FH**015T

H = High Temperature.



Special features / benefits

- **Special design of the mechanical seal chamber** for high temperature applications.
- **Standard mechanical seal** (EN12756) fitted on all models. **Easy to replace without removing the motor** from 5,5 kW up.
- **Hard metal intermediate bush support** (tungsten carbide) to increase the duration and capability of operating in extreme conditions, available on all sizes.
- **Balanced impeller design** to reduce axial thrust and extend the lifetime of standard motor bearings.
- **IE2** efficiency level (three-phase 0,12-0,749 kW), **IE3** efficiency level (three-phase 0,75 to 1000 kW) **standard motors**, 2-poles with blocked bearing **to support maximum thrust without limiting inlet pressure.**

Special configurations

A wide range of configurations is available for e-SV High Temperature pumps:

- Materials used: see the Materials section.
- Options for mechanical seals and gaskets: see the mechanical seals and gaskets section.
- Options for motors and configuration: see the motors section.

**e-SV SERIES - HIGH TEMPERATURE (...150°C)
50/60 Hz****Technical specifications - Design**

- 1: Special design of the mechanical seal chamber, assuring adequate lubrication triggered by the pumped liquid, thus extending product lifetime.
- 2: Balanced mechanical seal in order to withstand high pressures and temperatures.

Operating characteristics

For the hydraulic performances, please refer to the standard catalogue of e-SV.

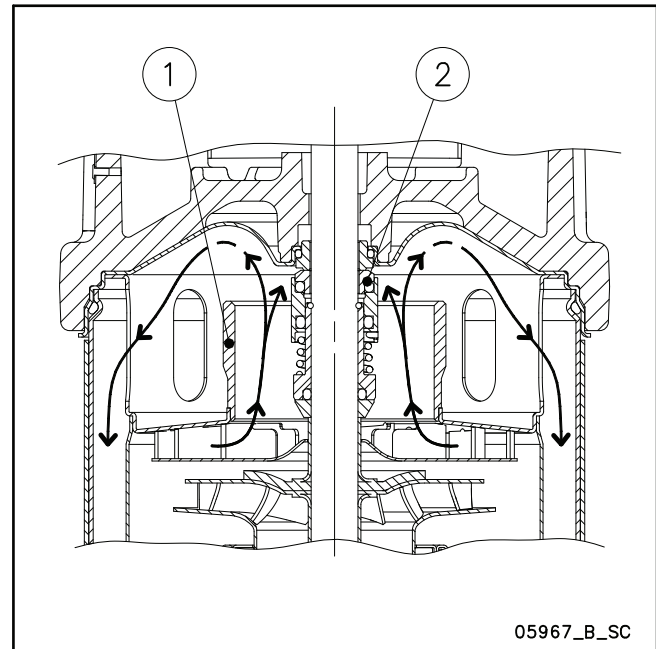

→ Route of pumped liquid.

**e-SV SERIES - HIGH TEMPERATURE (...150°C) 50/60 Hz
ELECTRIC PUMP CROSS SECTION AND MAIN COMPONENTS**

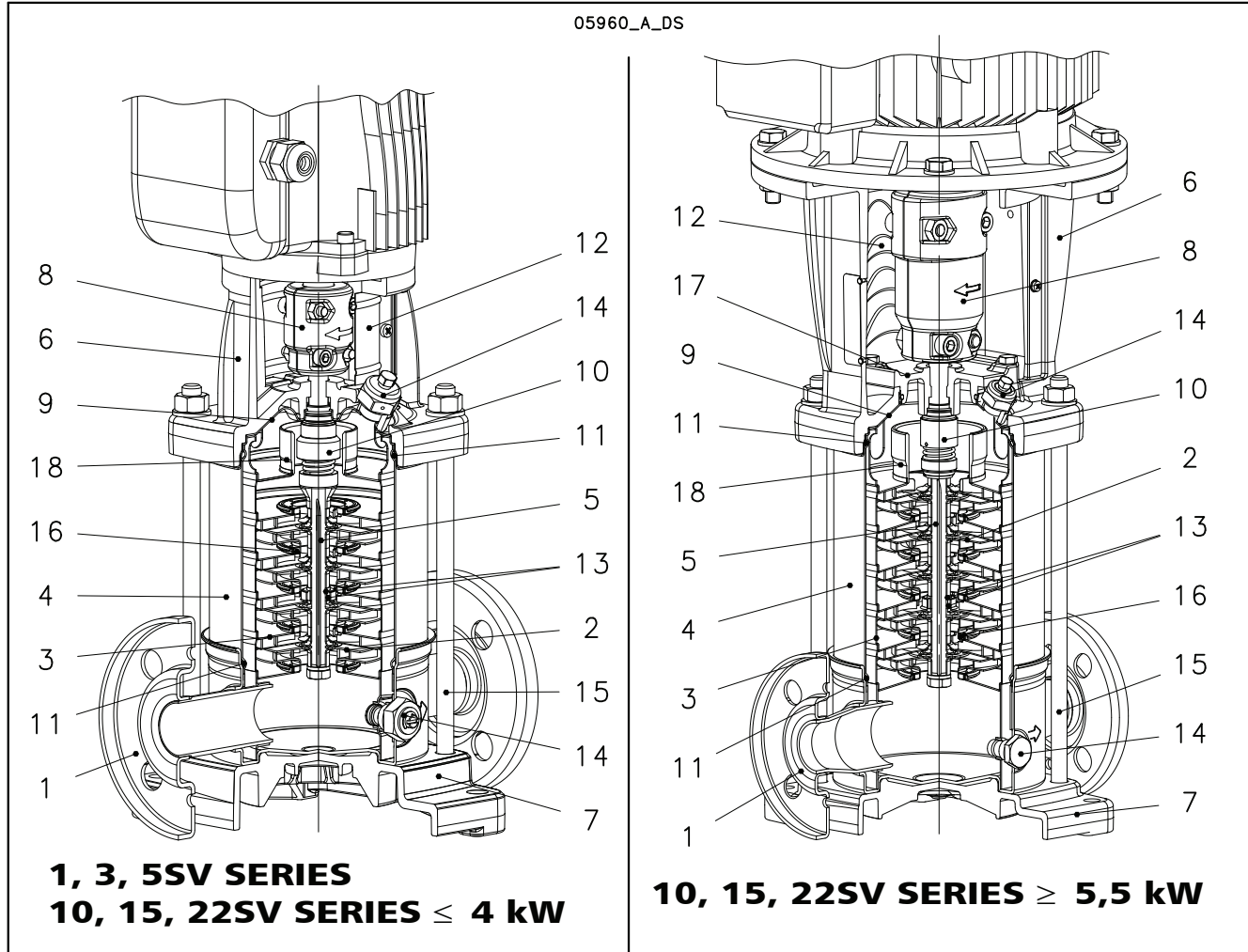

H VERSIONS

REF. N.	NAME	FH VERSION				NH VERSION			
		MATERIAL	REFERENCE STANDARDS		MATERIAL	REFERENCE STANDARDS			
			EUROPE	USA		EUROPE	USA		
1	Pump body	Stainless steel	1.4301	AISI 304	Stainless steel	1.4404	AISI 316L		
2	Impeller	Stainless steel	1.4301	AISI 304	Stainless steel	1.4404	AISI 316L		
3	Diffuser	Stainless steel	1.4301	AISI 304	Stainless steel	1.4404	AISI 316L		
4	Outer sleeve	Stainless steel	1.4301	AISI 304	Stainless steel	1.4404	AISI 316L		
5	Shaft	Stainless steel	1.4301	AISI 304	Stainless steel	1.4401	AISI 316		
6	Adapter	Cast iron	EN-JL1040	ASTM Class 35	Cast iron	EN-JL1040	ASTM Class 35		
7	Base	Aluminium	AC46100	-	Aluminium	AC46100	-		
8	Coupling	Aluminium	AC46100	-	Aluminium	AC46100	-		
9	Seal plate	Stainless steel	1.4301	AISI 304	Stainless steel	1.4404	AISI 316L		
10	Mechanical seal	Silicon carbide / Carbon / Special FKM				Silicon carbide / Carbon / Special FKM			
11	Elastomers	Special FKM				Special FKM			
12	Coupling protection	Stainless steel	1.4301	AISI 304	Stainless steel	1.4301	AISI 304		
13	Shaft sleeve and bushing	Tungsten carbide				Tungsten carbide			
14	Fill / drain plugs	Stainless steel	1.4301	AISI 304	Stainless steel	1.4401	AISI 316		
15	Tie rods	Galvanized steel	1.0765	-	Stainless steel	1.4057	AISI 431		
16	Wear ring	Technopolymer PPS				Technopolymer PPS			
17	Seal housing	Stainless steel	1.4308	AISI 304	Stainless steel	1.4408	AISI 316		
18	Final Diffuser	Stainless steel	1.4404	AISI 316L	Stainless steel	1.4404	AISI 316L		

1-22sv-FH_NH-en_b_tm

**e-SV SERIES - HIGH TEMPERATURE (...150°C) 50/60 Hz
ELECTRIC PUMP CROSS SECTION AND MAIN COMPONENTS**

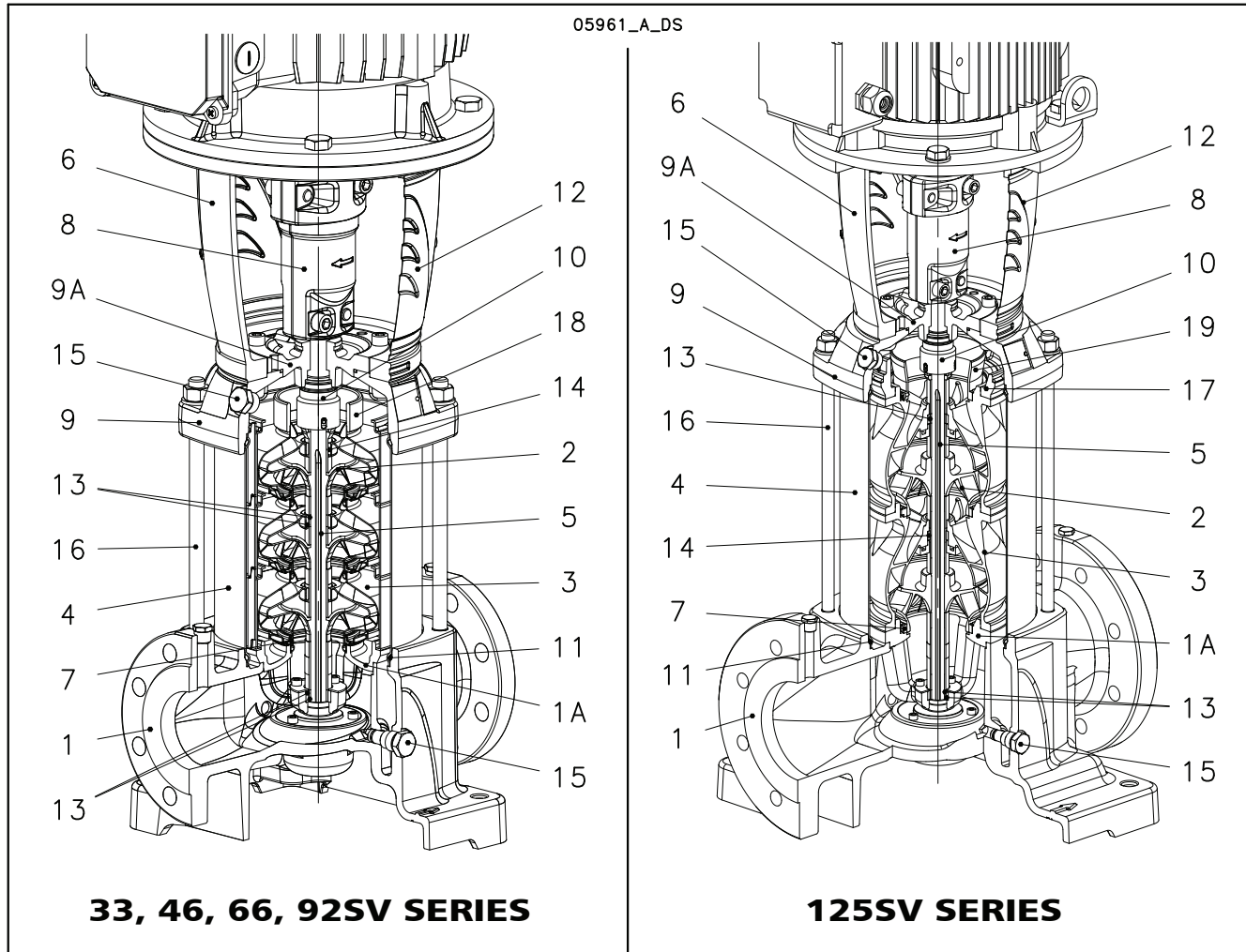

H VERSIONS

REF.	NAME	GH VERSION				NH VERSION			
		MATERIAL	REFERENCE STANDARDS		MATERIAL	REFERENCE STANDARDS			
			EUROPE	USA		EUROPE	USA		
1	Pump body	Cast iron	EN-JL1040	ASTM Class 35	Stainless steel	1.4408	AISI 316		
1A	Lower support 33-92SV	Cast iron	EN-JL1040	ASTM Class 35	Stainless steel	1.4408	AISI 316		
1A	Lower support 125SV	Stainless steel	1.4308	AISI 304	Stainless steel	1.4408	AISI 316		
2	Impeller 33-92SV	Stainless steel	1.4404	AISI 316L	Stainless steel	1.4404	AISI 316L		
3	Diffuser 33-92SV	Stainless steel	1.4301	AISI 304	Stainless steel	1.4404	AISI 316L		
2-3	Impeller, Diffuser 125SV	Stainless steel	1.4308	AISI 304	Stainless steel	1.4408	AISI 316		
4	Outer sleeve	Stainless steel	1.4301	AISI 304	Stainless steel	1.4404	AISI 316L		
5	Shaft	Stainless steel	1.4057	AISI 431	Stainless steel	1.4462	UNS S 31803		
6	Adapter	Cast iron	EN-JL1030	ASTM Class 25	Cast iron	EN-JL1030	ASTM Class 25		
6	Adapter (for 55kW)	Cast iron	EN-JS1050	ASTM A 536 80-55-06	Cast iron	EN-JS1050	ASTM A 536 80-55-06		
7	Wear ring	Technopolymer PPS			Technopolymer PPS				
8	Coupling	Cast iron	EN-JL1030	ASTM Class 25	Cast iron	EN-JL1030	ASTM Class 25		
8	Coupling (for 55kW)	Cast iron	EN-JS1050	ASTM A 536 80-55-06	Cast iron	EN-JS1050	ASTM A 536 80-55-06		
9-9A	Upper head, Seal housing	Cast iron	EN-JL1040	ASTM Class 35	Stainless steel	1.4408	AISI 316		
10	Mechanical seal	Silicon carbide / Carbon / Special FKM			Silicon carbide / Carbon / Special FKM				
11	Elastomers	Special FKM			Special FKM				
12	Coupling protection	Stainless steel	1.4301	AISI 304	Stainless steel	1.4301	AISI 304		
13	Shaft sleeve and bushing	Tungsten carbide			Tungsten carbide				
14	Bushing for diffuser	Carbon			Carbon				
15	Fill / drain / air plugs	Stainless steel	1.4401	AISI 316	Stainless steel	1.4401	AISI 316		
16	Tie rods	Galvaniz. steel	1.0765	-	Stainless steel	1.4057	AISI 431		
17	Adapter ring	Stainless steel	1.4308	AISI 304	Stainless steel	1.4408	AISI 316		
18	Final Diffuser	Stainless steel	1.4404	AISI 316L	Stainless steel	1.4404	AISI 316L		
19	Conveyor	Stainless steel	1.4401	AISI 316	Stainless steel	1.4401	AISI 316		

33-125sv-GH_NH-en_b_tm

**e-SV SERIES - HIGH TEMPERATURE (...150°C) 50/60 Hz
BALANCED MECHANICAL SEALS, ACCORDING TO EN 12756**

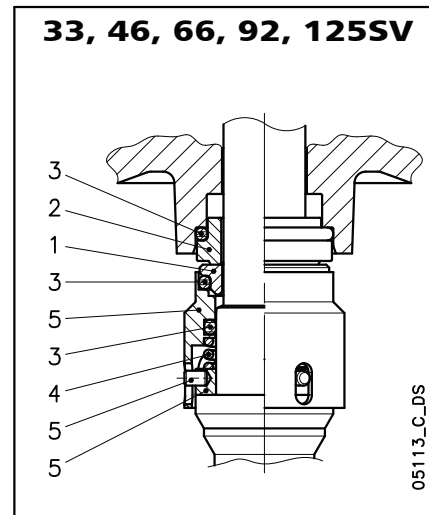
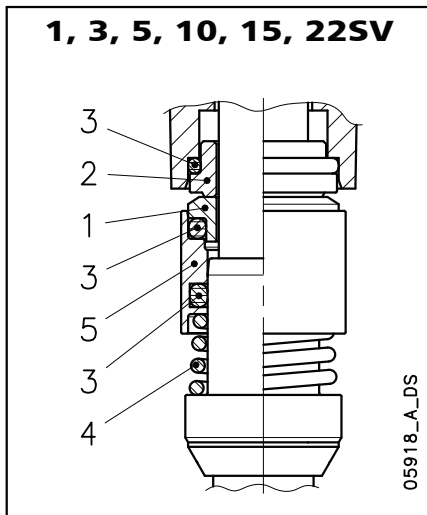

LIST OF MATERIALS

POSITION 1 - 2	POSITION 3	POSITION 4 - 5
Q ₁ : Silicon Carbide	X : Special FKM	G : AISI 316
A : Carbon metal-impregnated		

sv-at_ten-mec-en_b_tm

TYPE OF SEAL

TYPE	POSITION					TEMPERATURE (°C)
	1 ROTATING PART	2 STATIONARY PART	3 ELASTOMERS	4 SPRINGS	5 OTHER COMPONENTS	
MECHANICAL SEAL FOR USE WITH WATER						
Q ₁ A X G G	Q ₁	A	X	G	G	-10 +150
OTHER TYPES OF AVAILABLE MECHANICAL SEAL						
*Q ₁ Q ₁ X G G	Q ₁	Q ₁	X	G	G	-10 +150

* Versions with anti-rotation lock pin of the fixed part.

sv-at_tipi-ten-mec-en_b_tc

PRESSURE/TEMPERATURE APPLICATION LIMITS FOR COMPLETE PUMP

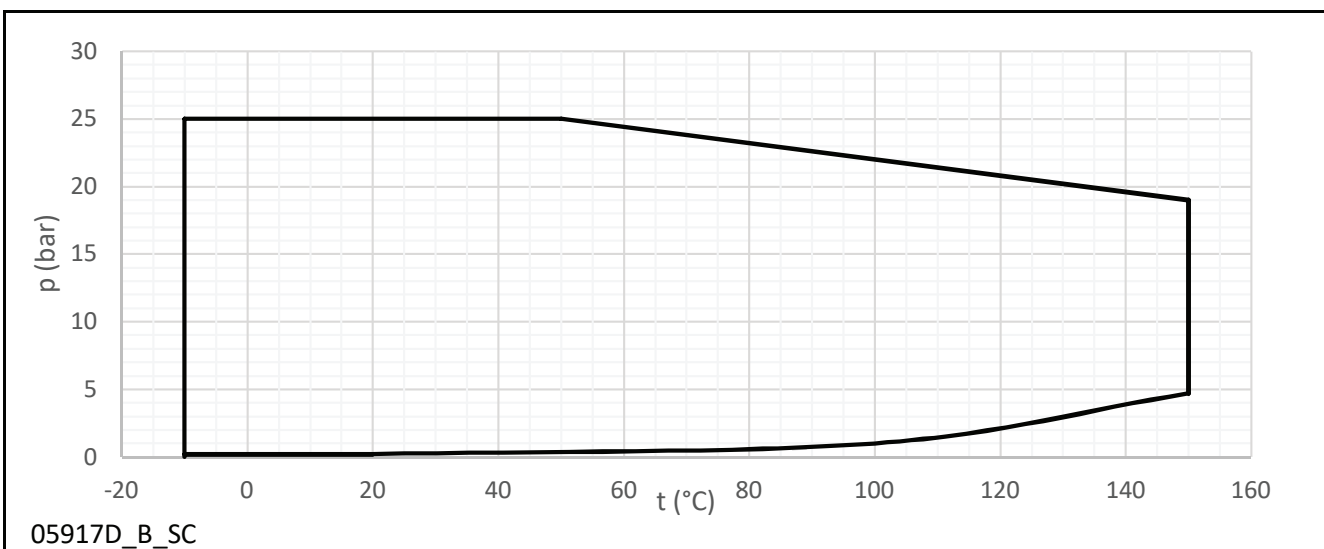

**e-SV SERIES - HIGH TEMPERATURE (...150°C)
DIMENSIONS AT 50/60 Hz**

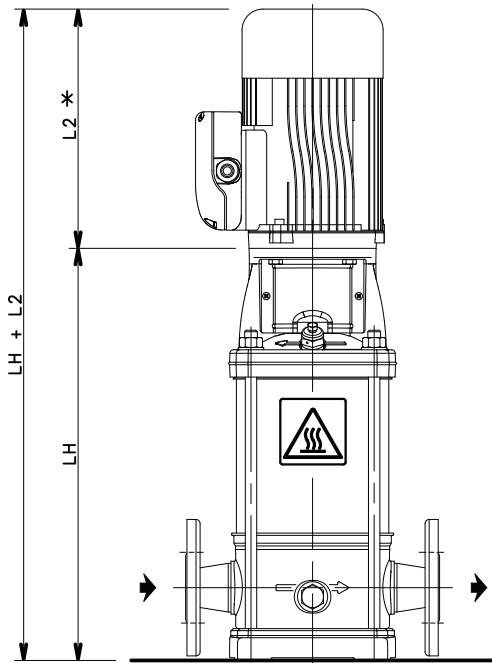

PUMP TYPE	DIMENSIONS (mm) LH	AVAILABLE STAGES		FLANGES
		50Hz	60Hz	PN
1SV-H	*L1+20	02÷37	02÷26	25
3SV-H	*L1+20	02÷31	02÷21	25
5SV-H	*L1+25	02÷30	02÷21	25
10SV-H	*L1=LH	02÷20	02÷13	25
15SV-H	*L1=LH	02÷15	02÷11	25
22SV-H	*L1=LH	02÷14	02÷10	25

*L1,*L2 = Standard product dimension, see e-SV catalogue.

1-22sv-h-en_b_td

1, 3, 5, 10, 15, 22SV SERIES

05966_A_DD

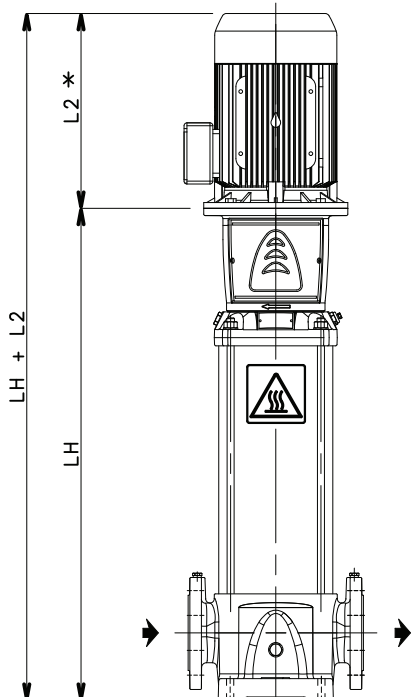

PUMP TYPE	DIMENSIONS (mm) LH	AVAILABLE STAGES		FLANGES
		50Hz	60Hz	PN
33SV-H	*L1=LH	1/1A÷9	1/1A÷6	25
46SV-H	*L1=LH	1/1A÷9	1/1A÷6	25
66SV-H	*L1=LH	1/1A÷7	1/1A÷5	25
92SV-H	*L1=LH	1/1A÷7/2A	1/1A÷4/2A	25
125SV-H	*L1=LH	1÷8/2A	1÷5/5A	25

*L1,*L2 = Standard product dimension, see e-SV catalogue.

33-125sv-h-en_a_td

33, 46, 66, 92, 125SV SERIES

e-SV SERIES - HIGH TEMPERATURE (...150°C) HYDRAULIC PERFORMANCE TABLE AT 50 Hz, 2 POLES

PUMP TYPE	RATED POWER		MEI ≥ (1)	PUMP TYPE	RATED POWER		MEI ≥ (1)	PUMP TYPE	RATED POWER		MEI ≥ (1)
	kW	HP			kW	HP			kW	HP	
1SV02	0,37	0,5	0,70	10SV01	0,75	1	0,70	46SV1/1A	3	4	0,70
1SV03	0,37	0,5	0,70	10SV02	0,75	1	0,70	46SV1	4	5,5	0,70
1SV04	0,37	0,5	0,70	10SV03	1,1	1,5	0,70	46SV2/2A	5,5	7,5	0,70
1SV05	0,37	0,5	0,70	10SV04	1,5	2	0,70	46SV2	7,5	10	0,70
1SV06	0,37	0,5	0,70	10SV05	2,2	3	0,70	46SV3/2A	11	15	0,70
1SV07	0,37	0,5	0,70	10SV06	2,2	3	0,70	46SV3	11	15	0,70
1SV08	0,55	0,75	0,70	10SV07	3	4	0,70	46SV4/2A	15	20	0,70
1SV09	0,55	0,75	0,70	10SV08	3	4	0,70	46SV4	15	20	0,70
1SV10	0,55	0,75	0,70	10SV09	4	5,5	0,70	46SV5/2A	18,5	25	0,70
1SV11	0,55	0,75	0,70	10SV10	4	5,5	0,70	46SV5	18,5	25	0,70
1SV12	0,75	1	0,70	10SV11	4	5,5	0,70	46SV6/2A	22	30	0,70
1SV13	0,75	1	0,70	10SV13	5,5	7,5	0,70	46SV6	22	30	0,70
1SV15	0,75	1	0,70	10SV15	5,5	7,5	0,70	46SV7/2A	30	40	0,70
1SV17	1,1	1,5	0,70	10SV17	7,5	10	0,70	46SV7	30	40	0,70
1SV19	1,1	1,5	0,70	10SV18	7,5	10	0,70	46SV8/2A	30	40	0,70
1SV22	1,1	1,5	0,70	10SV20	7,5	10	0,70	46SV8	30	40	0,70
1SV25	1,5	2	0,70	15SV01	1,1	1,5	0,70	46SV9/2A	30	40	0,70
1SV27	1,5	2	0,70	15SV02	2,2	3	0,70	46SV9	37	50	0,70
1SV30	1,5	2	0,70	15SV03	3	4	0,70	66SV1/1A	4	5,5	0,70
1SV32	2,2	3	0,70	15SV04	4	5,5	0,70	66SV1	5,5	7,5	0,70
1SV34	2,2	3	0,70	15SV05	4	5,5	0,70	66SV2/2A	7,5	10	0,70
1SV37	2,2	3	0,70	15SV06	5,5	7,5	0,70	66SV2/1A	11	15	0,70
3SV02	0,37	0,5	0,70	15SV07	5,5	7,5	0,70	66SV2	11	15	0,70
3SV03	0,37	0,5	0,70	15SV08	7,5	10	0,70	66SV3/2A	15	20	0,70
3SV04	0,37	0,5	0,70	15SV09	7,5	10	0,70	66SV3/1A	15	20	0,70
3SV05	0,55	0,75	0,70	15SV10	11	15	0,70	66SV3	18,5	25	0,70
3SV06	0,55	0,75	0,70	15SV11	11	15	0,70	66SV4/2A	18,5	25	0,70
3SV07	0,75	1	0,70	15SV13	11	15	0,70	66SV4/1A	22	30	0,70
3SV08	0,75	1	0,70	15SV15	15	20	0,70	66SV4	22	30	0,70
3SV09	1,1	1,5	0,70	22SV01	1,1	1,5	0,70	66SV5/2A	30	40	0,70
3SV10	1,1	1,5	0,70	22SV02	2,2	3	0,70	66SV5/1A	30	40	0,70
3SV11	1,1	1,5	0,70	22SV03	3	4	0,70	66SV5	30	40	0,70
3SV12	1,1	1,5	0,70	22SV04	4	5,5	0,70	66SV6/2A	30	40	0,70
3SV13	1,5	2	0,70	22SV05	5,5	7,5	0,70	66SV6/1A	30	40	0,70
3SV14	1,5	2	0,70	22SV06	7,5	10	0,70	66SV6	37	50	0,70
3SV16	1,5	2	0,70	22SV07	7,5	10	0,70	66SV7/2A	37	50	0,70
3SV19	2,2	3	0,70	22SV08	11	15	0,70	66SV7/1A	37	50	0,70
3SV21	2,2	3	0,70	22SV09	11	15	0,70	66SV7	45	60	0,70
3SV23	2,2	3	0,70	22SV10	11	15	0,70	92SV1/1A	5,5	7,5	0,60
3SV25	2,2	3	0,70	22SV12	15	20	0,70	92SV1	7,5	10	0,60
3SV27	3	4	0,70	22SV14	15	20	0,70	92SV2/2A	11	15	0,60
3SV29	3	4	0,70	33SV1/1A	2,2	3	0,70	92SV2	15	20	0,60
3SV31	3	4	0,70	33SV1	3	4	0,70	92SV3/2A	18,5	25	0,60
5SV02	0,37	0,5	0,70	33SV2/2A	4	5,5	0,70	92SV3	22	30	0,60
5SV03	0,55	0,75	0,70	33SV2/1A	4	5,5	0,70	92SV4/2A	30	40	0,60
5SV04	0,55	0,75	0,70	33SV2	5,5	7,5	0,70	92SV4	30	40	0,60
5SV05	0,75	1	0,70	33SV3/2A	5,5	7,5	0,70	92SV5/2A	37	50	0,60
5SV06	1,1	1,5	0,70	33SV3/1A	7,5	10	0,70	92SV5	37	50	0,60
5SV07	1,1	1,5	0,70	33SV3	7,5	10	0,70	92SV6/2A	45	60	0,60
5SV08	1,1	1,5	0,70	33SV4/2A	7,5	10	0,70	92SV6	45	60	0,60
5SV09	1,5	2	0,70	33SV4/1A	11	15	0,70	92SV7/2A	55	75	0,60
5SV10	1,5	2	0,70	33SV4	11	15	0,70	125SV1	7,5	10	-
5SV11	1,5	2	0,70	33SV5/2A	11	15	0,70	125SV2	15	20	-
5SV12	2,2	3	0,70	33SV5/1A	11	15	0,70	125SV3	22	30	-
5SV13	2,2	3	0,70	33SV5	15	20	0,70	125SV4	30	40	-
5SV14	2,2	3	0,70	33SV6/2A	15	20	0,70	125SV5	37	50	-
5SV15	2,2	3	0,70	33SV6/1A	15	20	0,70	125SV6	45	60	-
5SV16	2,2	3	0,70	33SV6	15	20	0,70	125SV7	55	75	-
5SV18	3	4	0,70	33SV7/2A	15	20	0,70	125SV8/2A	55	75	-
5SV21	3	4	0,70	33SV7/1A	18,5	25	0,70				
5SV23	4	5,5	0,70	33SV7	18,5	25	0,70				
5SV25	4	5,5	0,70	33SV8/2A	18,5	25	0,70				
5SV28	4	5,5	0,70	33SV8/1A	18,5	25	0,70				
5SV30	5,5	7,5	0,70	33SV8	22	30	0,70				
				33SV9/2A	22	30	0,70				
				33SV9/1A	22	30	0,70				
				33SV9	22	30	0,70				

Q = DELIVERY
H = HEAD
Pp = POWER
np = EFFICIENCY

For hydraulic performance values, consult the standard e-SV™ catalogue

(1) 1, 3, 5, 10, 15, 22SV Value referred to the F, T, N versions. R, V, C, K and P versions excluded.
33, 46SV Value referred to the N version with PN ≤ 25 bar (2500 kPa). G, P versions and N version with PN > 25 bar (2500 kPa) are excluded.
66, 92SV Value referred to the N version. G and P versions excluded.

1-125sv-BERp-2p50-en_b_th

**HIGH
TEMPERATURE
"BOILER"
...180°C
(50/60 Hz)**

e-SV SERIES - HIGH TEMPERATURE "BOILER" (...180°C) 50/60 Hz

Background and context

In applications where industrial boilers are used, pumps often have to deal with liquids at high temperatures. In these installations, pumps need to be specifically cooled down from excessive temperatures in the mechanical seal area, in order to ensure high performance levels. That's why Lowara has developed the e-SV "Boiler". This pump has a standard mechanical seal which extends its lifetime even when pumping liquids at very high temperatures.

Benefits of e-SV "Boiler"

Long-term mechanical seal performance:

Thanks to the special design of its housing, the seal is protected from the stress caused by high temperatures by means of a "natural" lubrication process which is triggered by the pumped liquid itself, and a cooling system which uses the air in the room. A degasser is also installed at the top of the pump in order to automatically eliminate the air in the seal area. The temperature decreased to 100°C in the mechanical seal area, together with the balanced mechanical seal and the high quality of the elastomers of the e-SV "Boiler" pump, assure excellent long-term performance, even in the harshest operating conditions.

Solidity: e-SV "Boiler" pumps are designed to operate in any application at temperatures up to 180°C and pressures up to 25 bar. Pump body and upper chamber in cast AISI 316, balanced mechanical seal, high quality elastomers, hard metal bush supports, double outer jacket: these are the key features of the e-SV "Boiler". To select the correct pump, consult the pressure-temperature diagram.

Easy and cost effective maintenance: the mechanical seal installed in e-SV "Boiler" pumps is a standard balanced mechanical seal (EN12756) which makes it cheap and easy to replace.

Identification code

e-SV "Boiler" models are identified by the letter "B" in the standard identification code of the e-SV product range and are available in AISI 316.

Example: 3SV13NB015T

B = "Boiler".



Special features / benefits

- **Special design of the final stage of the pump and of the mechanical seal chamber** for high temperature applications.
- **Pump body and upper chamber in cast AISI 316.**
- **Stainless steel PN25 degasser.**
- **Hard metal intermediate bush support** (tungsten carbide) to increase the duration and capability of operating in extreme conditions, available on all sizes.
- **Balanced impeller design** to reduce axial thrust and extend the lifetime of standard motor bearings.
- **Double outer jacket** to withstand pressures of up to 25 bar and temperatures of up to 180°C.
- **IE2 efficiency level** (three-phase 0,12-0,749 kW), **IE3 efficiency level** (three-phase 0,75 to 1000 kW **standard motors**, 2-poles with blocked bearing **to endure extreme thrusts without limiting inlet pressure.**

Special configurations

A wide range of configurations is available for e-SV "Boiler" pumps:

- Materials used: see the Materials section.
- Options for mechanical seals and gaskets: see the mechanical seals and gaskets section.
- Options for motors and configuration: see the motors section.

e-SV SERIES - HIGH TEMPERATURE "BOILER" (...180°C) 50/60 Hz

Technical specifications - Design

- 1: Balanced mechanical seal in order to withstand high pressures and temperatures.
- 2: Special upper chamber design with recirculation of the air in the room which lowers the temperature of the mechanical seal.
- 3: Degasser to eliminate the air in the mechanical seal area.
- 4: Double outer jacket design to withstand high pressures.

Operating characteristics

For the hydraulic performances, please refer to the standard catalogue of e-SV.

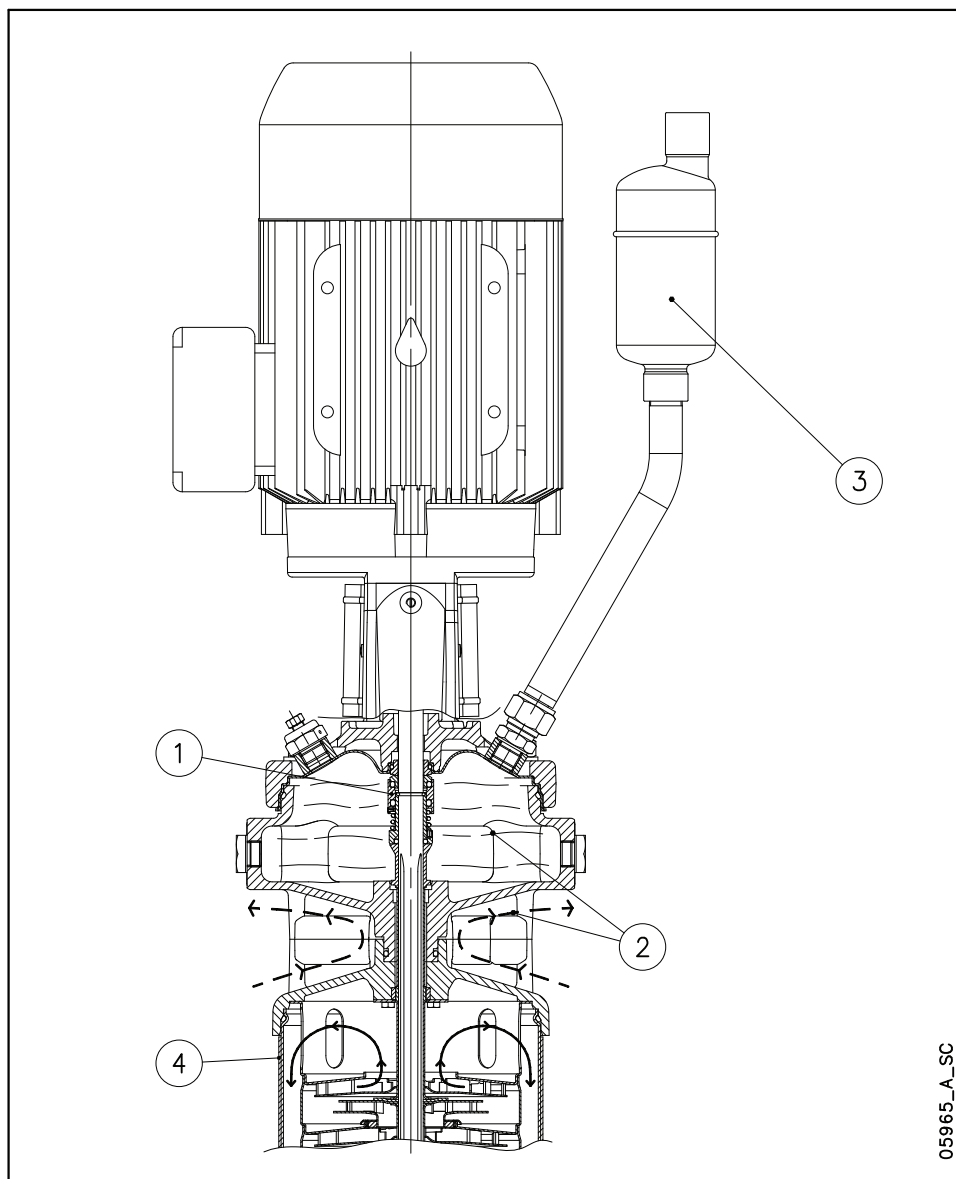

→ Route of pumped liquid.

**e-SV SERIES - HIGH TEMPERATURE "BOILER" (...180°C) 50/60 Hz
ELECTRIC PUMP CROSS SECTION AND MAIN COMPONENTS**

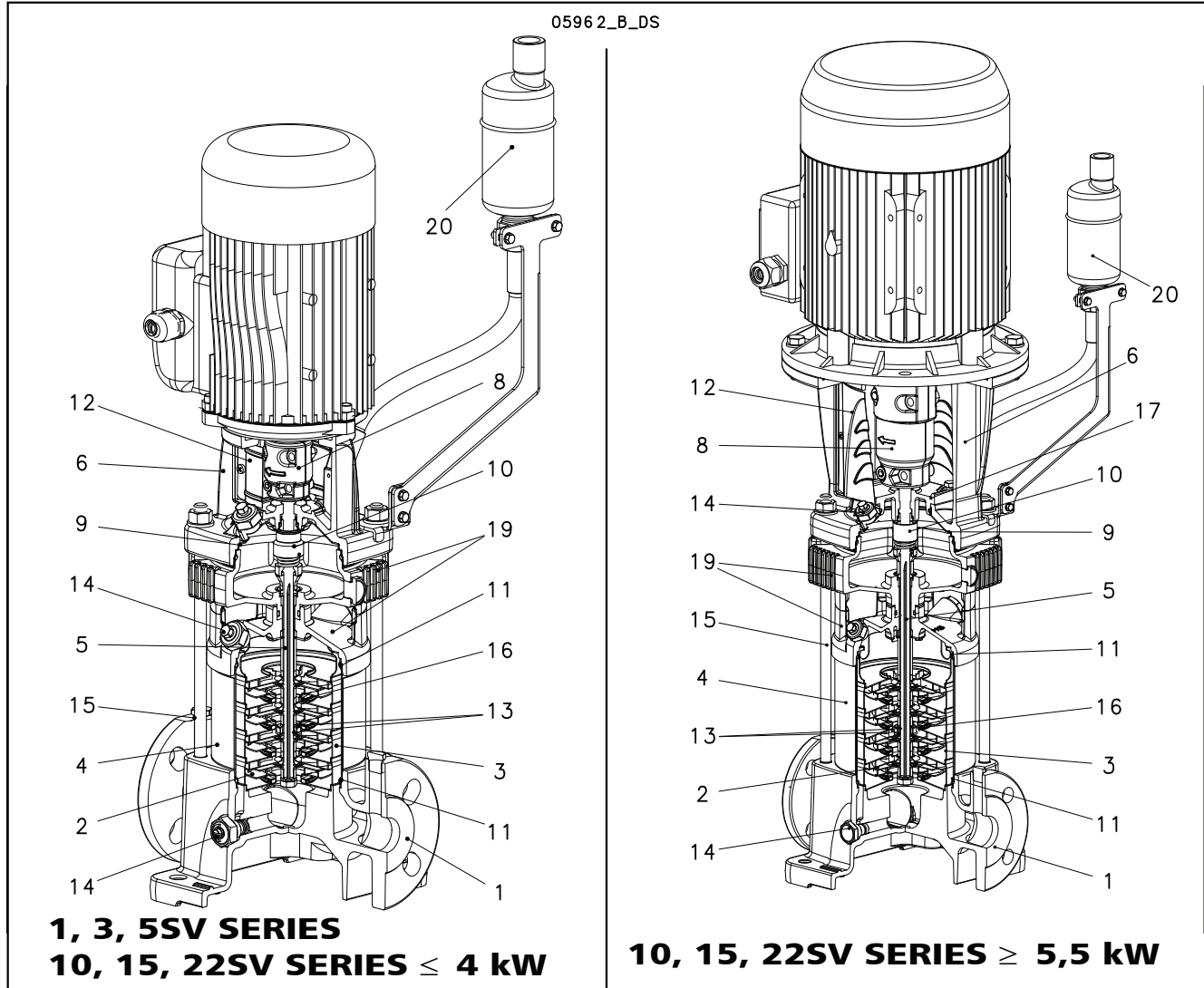

B VERSIONS

REF. N.	NAME	MATERIAL	REFERENCE STANDARDS	
			EUROPE	USA
1	Pump body	Stainless steel	EN 10213-4-GX5CrNiMo19-11-2 (1.4408)	AISI 316
2	Impeller	Stainless steel	EN 10088-1-X2CrNiMo17-12-2 (1.4404)	AISI 316L
3	Diffuser	Stainless steel	EN 10088-1-X2CrNiMo17-12-2 (1.4404)	AISI 316L
4	Outer sleeve	Stainless steel	EN 10088-1-X2CrNiMo17-12-2 (1.4404)	AISI 316L
5	Shaft	Stainless steel	EN 10088-1-X5CrNiMo17-12-2 (1.4401)	AISI 316
6	Adapter	Cast iron	EN 1561-GJL-250 (JL1040)	ASTM Class 35
8	Coupling	Aluminium	EN 1706-AC-AISI11Cu2 (Fe) (AC46100)	-
9	Seal plate	Stainless steel	EN 10088-1-X2CrNiMo17-12-2 (1.4404)	AISI 316L
10	Mechanical seal	Silicon carbide / Carbon / Special FKM		
11	Elastomers	Special FKM		
12	Coupling protection	Stainless steel	EN 10088-1-X5CrNi18-10 (1.4301)	AISI 304
13	Shaft sleeve and bushing	Tungsten carbide		
14	Fill / drain plugs	Stainless steel	EN 10088-1-X5CrNiMo17-12-2 (1.4401)	AISI 316
15	Tie rods	Stainless steel	EN 10088-1-X17CrNi16-2 (1.4057)	AISI 431
16	Wear ring	Technopolymer PPS		
17	Seal housing	Stainless steel	EN 10213-4-GX5CrNiMo19-11-2 (1.4408)	AISI 316
19	Upper seal chamber	Stainless steel	EN 10213-4-GX5CrNiMo19-11-2 (1.4408)	AISI 316
20	Air vent	Stainless steel	EN 10088-1-X2CrNi19-11 (1.4306)	AISI 304L

1-22sv-b-en_b_tm

**e-SV SERIES - HIGH TEMPERATURE "BOILER" (...180°C) 50/60 Hz
ELECTRIC PUMP CROSS SECTION AND MAIN COMPONENTS**

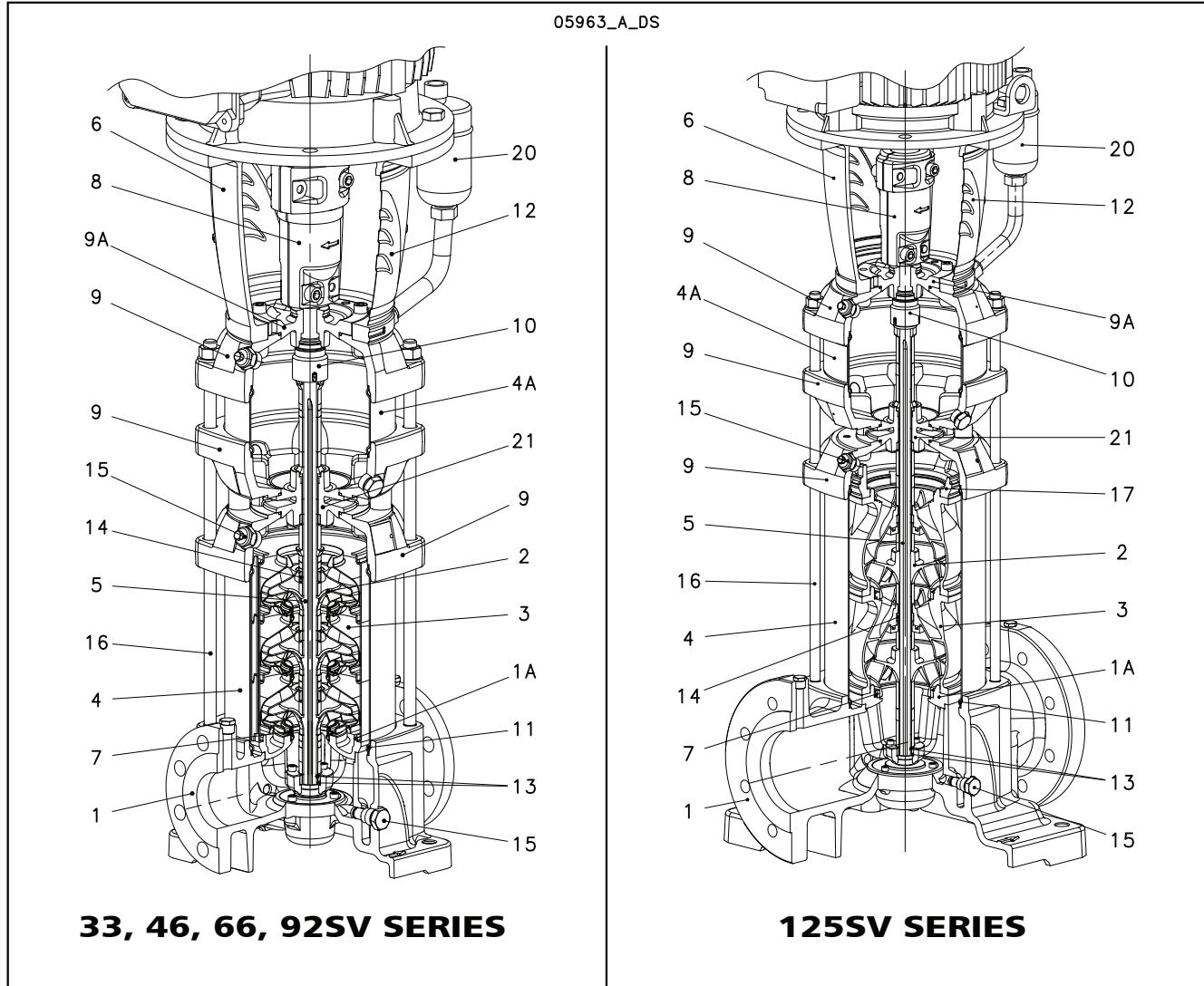

B VERSIONS

REF. N.	NAME	MATERIAL	REFERENCE STANDARDS	
			EUROPE	USA
1	Pump body	Stainless steel	EN 10213-4-GX5CrNiMo19-11-2 (1.4408)	AISI 316
1A	Lower support	Stainless steel	EN 10213-4-GX5CrNiMo19-11-2 (1.4408)	AISI 316
2-3	Impeller, Diffuser 33SV-92SV	Stainless steel	EN 10088-1-X2CrNiMo17-12-2 (1.4404)	AISI 316L
2-3	Impeller, Diffuser 125SV	Stainless steel	EN 10213-4-GX5CrNiMo19-11-2 (1.4408)	AISI 316
4-4A	Outer sleeve	Stainless steel	EN 10088-1-X2CrNiMo17-12-2 (1.4404)	AISI 316L
5	Shaft	Duplex stainless steel	EN 10088-1-X2CrNiMoN22-5-3 (1.4462)	UNS S 31803
6	Adapter (up to 45kW) Adapter (for higher powers)	Cast iron Cast iron	EN 1561-GJL-200 (JL1030) EN 1563-GJS-500-7 (JS1050)	ASTM Class 25 ASTM A 536 80-55-06
7	Wear ring	Technopolymer PPS		
8	Coupling (up to 45kW) Coupling (for higher powers)	Cast iron Cast iron	EN 1561-GJL-200 (JL1030) EN 1563-GJS-500-7 (JS1050)	ASTM Class 25 ASTM A 536 80-55-06
9-9A	Upper head, Seal housing	Stainless steel	EN 10213-4-GX5CrNiMo19-11-2 (1.4408)	AISI 316
10	Mechanical seal	Carburo di silicio / Carbone / Special FKM		
11	Elastomers	Special FKM		
12	Coupling protection	Stainless steel	EN 10088-1-X5CrNi18-10 (1.4301)	AISI 304
13	Shaft sleeve and bushing	Tungsten carbide		
14	Bushing for diffuser	Carbon		
15	Fill / drain / air plugs	Stainless steel	EN 10088-1-X5CrNiMo17-12-2 (1.4401)	AISI 316
16	Tie rods	Stainless steel	EN 10088-1-X17CrNi16-2 (1.4057)	AISI 431
17	Adapter ring	Stainless steel	EN 10213-4-GX5CrNiMo19-11-2 (1.4408)	AISI 316
20	Air vent	Stainless steel	EN 10088-1-X2CrNi19-11 (1.4306)	AISI 304L
21	Separating flange	Stainless steel	EN 10213-4-GX5CrNiMo19-11-2 (1.4408)	AISI 316

**e-SV SERIES - HIGH TEMPERATURE "BOILER" (...180°C) 50/60 Hz
BALANCED MECHANICAL SEALS, ACCORDING TO EN 12756**

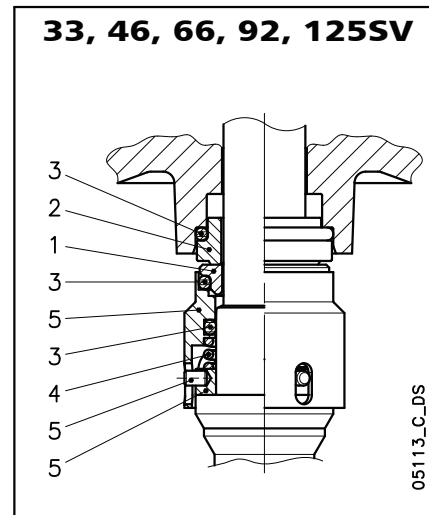
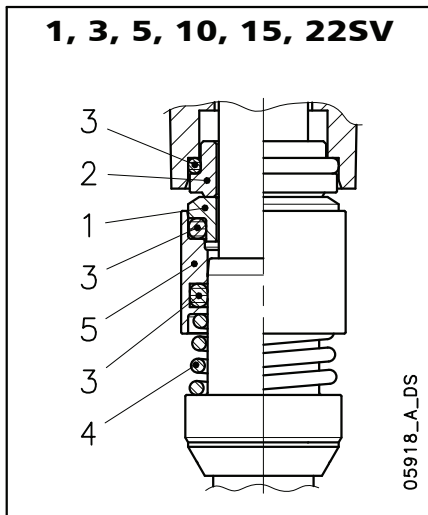

LIST OF MATERIALS

POSITION 1 - 2	POSITION 3	POSITION 4 - 5
Q ₁ : Silicon Carbide	X : Special FKM	G : AISI 316
A : Carbon metal-impregnated		

sv-180_ten-mec-en_b_tm

TYPE OF SEAL

TYPE	POSITION					TEMPERATURE (°C)
	1 ROTATING PART	2 STATIONARY PART	3 ELASTOMERS	4 SPRINGS	5 OTHER COMPONENTS	
MECHANICAL SEAL FOR USE WITH WATER						
Q ₁ A X G G	Q ₁	A	X	G	G	-10 +180
OTHER TYPES OF AVAILABLE MECHANICAL SEAL						
*Q ₁ Q ₁ X G G	Q ₁	Q ₁	X	G	G	-10 +180

* Versions with anti-rotation lock pin of the fixed part.

sv-180_tipi-ten-mec-en_c_tc

PRESSURE/TEMPERATURE APPLICATION LIMITS FOR COMPLETE PUMP

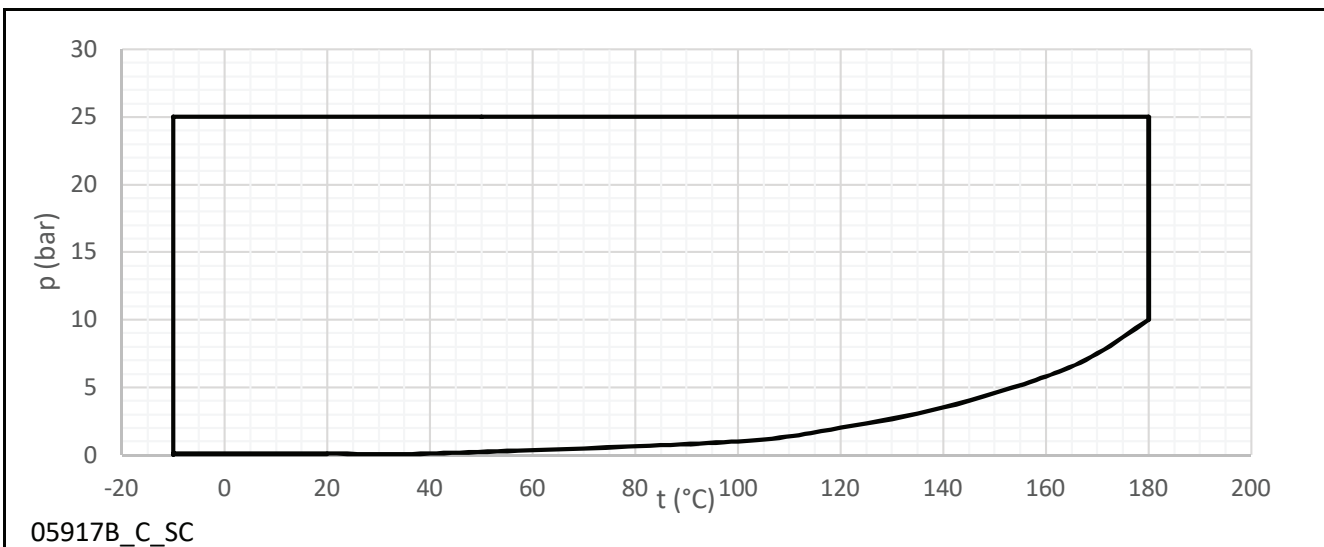

**e-SV SERIES - HIGH TEMPERATURE "BOILER" (...180°C)
DIMENSIONS AT 50/60 Hz**

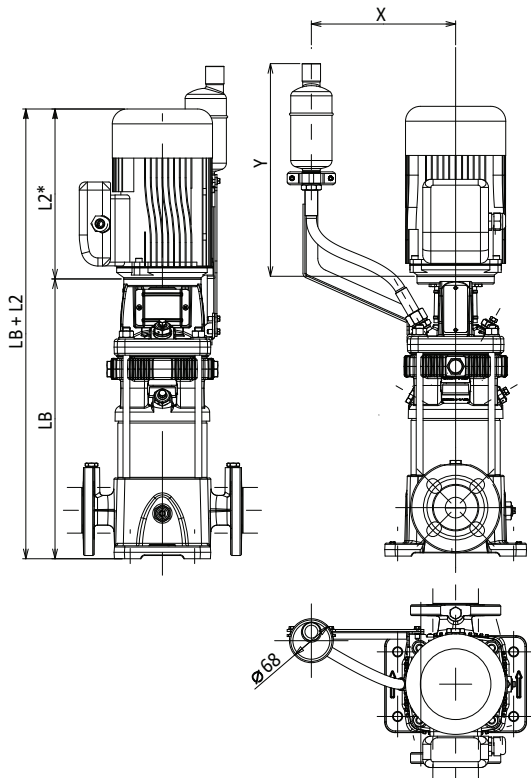

1, 3, 5, 10, 15, 22SV SERIES

PUMP TYPE	DIMENSIONS (mm) LB	AVAILABLE STAGES		FLANGES PN
		50Hz	60Hz	
1SV-B	*L1+105	02÷37	02÷26	25
3SV-B	*L1+105	02÷31	02÷21	25
5SV-B	*L1+130	02	02	25
5SV-B	*L1+105	03÷30	02÷21	25
10SV-B	*L1+147	01÷20	01÷13	25
15SV-B	*L1+153	01÷15	01÷11	25
22SV-B	*L1+153	01÷14	01÷10	25

*L1,*L2 = Standard product dimension, see e-SV catalogue.

PUMP TYPE	MOTOR TYPE	DIMENSIONS mm	
		X	Y
1SV ÷ 5SV	from 0,37 ÷ 0,55 kW	224	338
1SV ÷ 5SV	from 0,75 ÷ 1,1 kW		328
1SV ÷ 5SV	from 1,5 ÷ 2,2 kW		318
1SV ÷ 5SV	from 3 ÷ 4 kW		308
5SV	from 5,5 kW		288
10SV ÷ 22SV	from 0,75 ÷ 1,1 kW	236	309
10SV ÷ 22SV	from 1,5 ÷ 2,2 kW		299
10SV ÷ 22SV	from 3 ÷ 4 kW		289
10SV ÷ 22SV	from 5,5 ÷ 7,5 kW		223
10SV ÷ 22SV	from 11 ÷ 18,5 kW		193

1-22sv-b-en_c_td

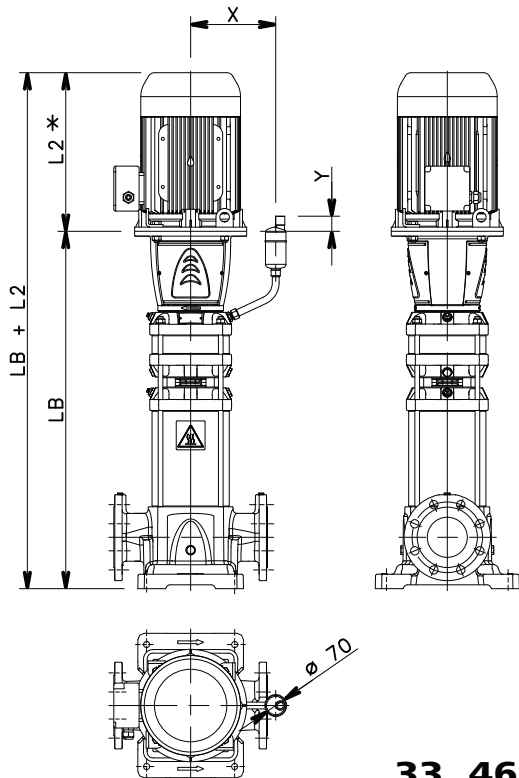

33, 46, 66, 92, 125SV SERIES

PUMP TYPE	DIMENSIONS (mm) LB	AVAILABLE STAGES		FLANGES PN
		50Hz	60Hz	
33SV-B	*L1+225	1/1A÷9	1/1A÷6	25
46SV-B	*L1+225	1/1A÷9	1/1A÷6	25
66SV-B	*L1+235	1/1A÷7	1/1A÷5	25
92SV-B	*L1+235	1/1A÷7/2A	1/1A÷4/2A	25
125SV-B	*L1+235	1÷8/2A	1÷5/5A	25

*L1,*L2 = Standard product dimension, see e-SV catalogue.

PUMP TYPE	MOTOR TYPE	DIMENSIONS mm	
		X	Y
33SV ÷ 46SV	from 2,2 ÷ 4 kW	265	108
66SV	from 2,2 ÷ 4 kW	265	119
33SV ÷ 46SV	from 5,5 ÷ 7,5 kW	265	88
66SV ÷ 125SV	from 5,5 ÷ 7,5 kW	265	99
33SV ÷ 46SV	from 11 ÷ 45 kW	265	53
66SV ÷ 125SV	from 11 ÷ 45 kW	265	64
92SV ÷ 125SV	from 55 kW	315	58

33-125sv-b-en_c_td

05968_B_DD

e-SV SERIES - HIGH TEMPERATURE "BOILER" (...180°C) HYDRAULIC PERFORMANCE TABLE AT 50 Hz, 2 POLES

PUMP TYPE	RATED POWER		MEI ≥ (1)
	kW	HP	
1SV02	0,37	0,5	0,70
1SV03	0,37	0,5	0,70
1SV04	0,37	0,5	0,70
1SV05	0,37	0,5	0,70
1SV06	0,37	0,5	0,70
1SV07	0,37	0,5	0,70
1SV08	0,55	0,75	0,70
1SV09	0,55	0,75	0,70
1SV10	0,55	0,75	0,70
1SV11	0,55	0,75	0,70
1SV12	0,75	1	0,70
1SV13	0,75	1	0,70
1SV15	0,75	1	0,70
1SV17	1,1	1,5	0,70
1SV19	1,1	1,5	0,70
1SV22	1,1	1,5	0,70
1SV25	1,5	2	0,70
1SV27	1,5	2	0,70
1SV30	1,5	2	0,70
1SV32	2,2	3	0,70
1SV34	2,2	3	0,70
1SV37	2,2	3	0,70
3SV02	0,37	0,5	0,70
3SV03	0,37	0,5	0,70
3SV04	0,37	0,5	0,70
3SV05	0,55	0,75	0,70
3SV06	0,55	0,75	0,70
3SV07	0,75	1	0,70
3SV08	0,75	1	0,70
3SV09	1,1	1,5	0,70
3SV10	1,1	1,5	0,70
3SV11	1,1	1,5	0,70
3SV12	1,1	1,5	0,70
3SV13	1,5	2	0,70
3SV14	1,5	2	0,70
3SV16	1,5	2	0,70
3SV19	2,2	3	0,70
3SV21	2,2	3	0,70
3SV23	2,2	3	0,70
3SV25	2,2	3	0,70
3SV27	3	4	0,70
3SV29	3	4	0,70
3SV31	3	4	0,70
5SV02	0,37	0,5	0,70
5SV03	0,55	0,75	0,70
5SV04	0,55	0,75	0,70
5SV05	0,75	1	0,70
5SV06	1,1	1,5	0,70
5SV07	1,1	1,5	0,70
5SV08	1,1	1,5	0,70
5SV09	1,5	2	0,70
5SV10	1,5	2	0,70
5SV11	1,5	2	0,70
5SV12	2,2	3	0,70
5SV13	2,2	3	0,70
5SV14	2,2	3	0,70
5SV15	2,2	3	0,70
5SV16	2,2	3	0,70
5SV18	2,2	3	0,70
5SV21	3	4	0,70
5SV23	4	5,5	0,70
5SV25	4	5,5	0,70
5SV28	4	5,5	0,70
5SV30	5,5	7,5	0,70

PUMP TYPE	RATED POWER		MEI ≥ (1)
	kW	HP	
10SV02	0,75	1	0,70
10SV03	1,1	1,5	0,70
10SV04	1,5	2	0,70
10SV05	2,2	3	0,70
10SV06	2,2	3	0,70
10SV07	3	4	0,70
10SV08	3	4	0,70
10SV09	4	6	0,70
10SV10	4	5,5	0,70
10SV11	4	5,5	0,70
10SV13	5,5	7,5	0,70
10SV15	5,5	7,5	0,70
10SV17	7,5	10	0,70
10SV18	7,5	10	0,70
10SV20	7,5	10	0,70
15SV02	2,2	3	0,70
15SV03	3	4	0,70
15SV04	4	5,5	0,70
15SV05	4	5,5	0,70
15SV06	5,5	7,5	0,70
15SV07	5,5	7,5	0,70
15SV08	7,5	10	0,70
15SV09	7,5	10	0,70
15SV10	11	15	0,70
15SV11	11	15	0,70
15SV13	11	15	0,70
15SV15	15	20	0,70
22SV01	1,1	1,5	0,70
22SV02	2,2	3	0,70
22SV03	3	4	0,70
22SV04	4	5,5	0,70
22SV05	5,5	7,5	0,70
22SV06	7,5	10	0,70
22SV07	7,5	10	0,70
22SV08	11	15	0,70
22SV09	11	15	0,70
22SV10	11	15	0,70
22SV12	15	20	0,70
22SV14	15	20	0,70
33SV1/1A	2,2	3	0,70
33SV1	3	4	0,70
33SV2/2A	4	5,5	0,70
33SV2/1A	4	5,5	0,70
33SV2	5,5	7,5	0,70
33SV3/2A	5,5	7,5	0,70
33SV3/1A	7,5	10	0,70
33SV3	7,5	10	0,70
33SV4/2A	7,5	10	0,70
33SV4/1A	11	15	0,70
33SV4	11	15	0,70
33SV5/2A	11	15	0,70
33SV5/1A	11	15	0,70
33SV5	15	20	0,70
33SV6/2A	15	20	0,70
33SV6/1A	15	20	0,70
33SV6	15	20	0,70
33SV7/2A	15	20	0,70
33SV7/1A	18,5	25	0,70
33SV7	18,5	25	0,70
33SV8/2A	18,5	25	0,70
33SV8/1A	18,5	25	0,70
33SV8	22	30	0,70
33SV9/2A	22	30	0,70
33SV9/1A	22	30	0,70
33SV9	22	30	0,70

PUMP TYPE	RATED POWER		MEI ≥ (1)
	kW	HP	
46SV1/1A	3	4	0,70
46SV1	4	5,5	0,70
46SV2/2A	5,5	7,5	0,70
46SV2	7,5	10	0,70
46SV3/2A	11	15	0,70
46SV3	11	15	0,70
46SV4/2A	15	20	0,70
46SV4	15	20	0,70
46SV5/2A	18,5	25	0,70
46SV5	18,5	25	0,70
46SV6/2A	22	30	0,70
46SV6	22	30	0,70
46SV7/2A	30	40	0,70
46SV7	30	40	0,70
46SV8/2A	30	40	0,70
46SV8	30	40	0,70
46SV9/2A	30	40	0,70
46SV9	37	50	0,70
66SV1/1A	4	5,5	0,70
66SV1	5,5	7,5	0,70
66SV2/2A	7,5	10	0,70
66SV2/1A	11	15	0,70
66SV2	11	15	0,70
66SV3/2A	15	20	0,70
66SV3/1A	15	20	0,70
66SV3	18,5	25	0,70
66SV4/2A	18,5	25	0,70
66SV4/1A	22	30	0,70
66SV4	22	30	0,70
66SV5/2A	30	40	0,70
66SV5/1A	30	40	0,70
66SV5	30	40	0,70
66SV6/2A	30	40	0,70
66SV6/1A	30	40	0,70
66SV6	37	50	0,70
66SV7/2A	37	50	0,70
66SV7/1A	37	50	0,70
66SV7	45	60	0,70
92SV1/1A	5,5	7,5	0,60
92SV1	7,5	10	0,60
92SV2/2A	11	15	0,60
92SV2	15	20	0,60
92SV3/2A	18,5	25	0,60
92SV3	22	30	0,60
92SV4/2A	30	40	0,60
92SV4	30	40	0,60
92SV5/2A	37	50	0,60
92SV5	37	50	0,60
92SV6/2A	45	60	0,60
92SV6	45	60	0,60
92SV7/2A	55	75	0,60
125SV1	7,5	10	-
125SV2	15	20	-
125SV3	22	30	-
125SV4	30	40	-
125SV5	37	50	-
125SV6	45	60	-
125SV7	55	75	-
125SV8/2A	55	75	-

Q = DELIVERY
H = HEAD
Pp = POWER
np = EFFICIENCY

For hydraulic performance values, consult the standard e-SV™ catalogue

(1) 1, 3, 5, 10, 15, 22SV Value referred to the F, T, N, R versions. V, C, K and P versions excluded.

1-125sv-HERP-2p50-en_b_th

33, 46SV Value referred to the G and N versions with PN ≤ 25 bar (2500 kPa). G and N versions with PN > 25 bar (2500 kPa) and P version are excluded.

66, 92SV Value referred to the G, N versions. P version excluded.

4-POLE VERSIONS (50/60 Hz)

e-SV SERIES - 4-POLE VERSION 50/60 Hz

Background and context

In the building services market, reducing the level of noise of the pumping equipment is one of the main goals of architects and facilities managers to bring more comfort to our life. In water boosting systems or in cooling and heating installations, often architects and contractors are looking at quiet operational systems. Therefore Lowara has developed the e-SV series with 4 pole versions: a pump which delivers a quiet and reliable solution to the most noise sensitive applications.

Benefits of e-SV 4 pole

Low level of noise: e-SV 4 pole, by reducing the speed of the pump by 50% allows delivering very quiet operation.

Wide range of performances: e-SV 4 pole is available from 1SV to 125SV, from 0,25 kW to 15 kW.

The efficiency values of e-SV 4 pole are comparable to the e-SV series with 2 poles.

Increased performance with HYDROVAR™: e-SV 4 pole combined with HYDROVAR™, the variable speed driver developed by Lowara, allows an additional reduction of the noise of the pumping system. HYDROVAR™, by smoothing the ramping up and down of the pump, reduces the speed of the water in the piping and as a consequence the noise made by the full installation.

Code identification

e-SV 4 pole version is identified with a "4" in the product codification of the whole e-SV range.

Example: 3SV11F002**4**T

4 = 4 pole version.



Special features / product benefits

- **Hard material intermediate bush bearing** (Tungsten Carbide) to improve life and ability to withstand heavy duty application on all sizes.
- **Supplied three-phase surface motors with IE2 efficiency level (for power < 0,75 kW) or IE3 efficiency level (for power ≥ 0,75 kW).**
- **HYDROVAR™ drive available on all models to allow e-SV 4 pole into an intelligent, variable speed system.** Ideal for single pumping solution or multiple pumping set solution (up to 8 pumps).
- **Standard mechanical seal (EN12756) fitted on all models. Easy to replace without removing the motor** from 5,5 kW up.

Special configurations

e-SV 4 pole offers the same range of configuration of the standard e-SV series.

- Materials used: see the Materials section.
- Options for mechanical seals and gaskets: see the mechanical seals and gaskets section.
- Options for motors and configuration: see the motors section.
- HYDROVAR™ system included.

e-SV SERIES

HYDRAULIC PERFORMANCE RANGE AT 50 Hz, 4-POLE

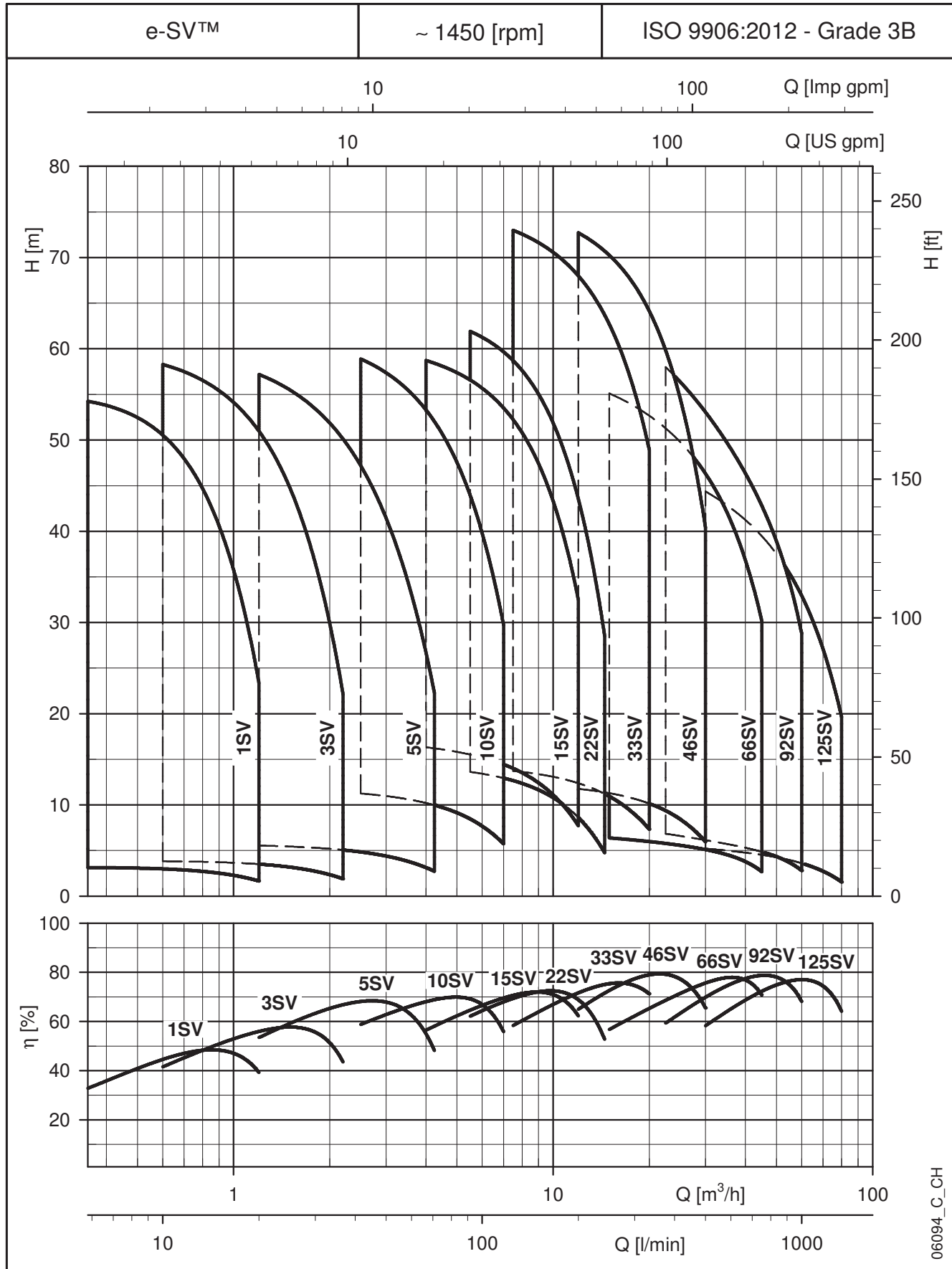

06094_C_CH

1, 3, 5, 10, 15, 22SV SERIES HYDRAULIC PERFORMANCE TABLE AT 50 Hz, 4-POLE

PUMP TYPE	RATED POWER		Q = DELIVERY													
			l/min 0	5,84	10	12,5	15	18	20	22	25	30	36	50	60	70,83
	kW	HP	m ³ /h 0	0,4	0,6	0,8	0,9	1,1	1,2	1,3	1,5	1,8	2,2	3,0	3,6	4,2
H = TOTAL HEAD IN METRES OF COLUMN OF WATER																
1SV02..4	0,25	0,34	3,1	3,1	3,0	2,8	2,5	2,1	1,7							
1SV05..4	0,25	0,34	7,7	7,8	7,4	6,9	6,2	5,0	4,0							
1SV08..4	0,25	0,34	12,2	12,4	11,7	10,9	9,8	7,9	6,3							
1SV11..4	0,25	0,34	16,7	16,9	16,0	14,9	13,3	10,7	8,5							
1SV15..4	0,25	0,34	22,6	22,9	21,6	20,0	17,8	14,3	11,3							
1SV19..4	0,25	0,34	28,8	29,4	27,7	25,6	22,8	18,2	14,4							
1SV22..4	0,25	0,34	33,2	33,8	31,7	29,3	26,0	20,6	16,2							
1SV27..4	0,25	0,34	40,1	40,4	38,0	35,2	31,1	24,3	18,6							
1SV30..4	0,25	0,34	44,4	44,6	41,9	38,6	34,0	26,5	20,1							
1SV34..4	0,25	0,34	50,0	50,2	46,9	43,1	37,9	29,3	22,1							
1SV37..4	0,25	0,34	54,2	54,2	50,5	46,4	40,6	31,2	23,4							
3SV02..4	0,25	0,34	3,8		3,8	3,8	3,7	3,6	3,5	3,4	3,2	2,7	2,0			
3SV05..4	0,25	0,34	9,5		9,5	9,4	9,2	8,9	8,6	8,3	7,8	6,7	4,8			
3SV08..4	0,25	0,34	15,1		14,9	14,7	14,4	14,0	13,6	13,1	12,2	10,4	7,4			
3SV11..4	0,25	0,34	20,6		20,3	20,0	19,6	18,9	18,3	17,7	16,5	13,9	9,8			
3SV14..4	0,25	0,34	26,1		25,8	25,3	24,8	23,9	23,1	22,2	20,7	17,3	12,0			
3SV19..4	0,25	0,34	33,3		32,6	32,0	31,3	30,0	29,0	27,9	25,8	21,5	14,5			
3SV23..4	0,25	0,34	42,2		40,9	40,1	39,0	37,4	36,0	34,5	31,8	26,1	17,2			
3SV27..4	0,37	0,5	49,7		48,5	47,5	46,3	44,4	42,9	41,1	38,0	31,4	21,0			
3SV33..4	0,37	0,5	60,2		58,3	57,0	55,4	53,0	51,0	48,7	44,8	36,5	23,7			
5SV03..4	0,25	0,34	5,7						6	6	5	5	5,1	4,4	3,7	2,7
5SV06..4	0,25	0,34	11,3						10,9	10,8	10,7	10,4	9,9	8,5	7,0	5,0
5SV09..4	0,25	0,34	16,8						16,1	16,0	15,7	15,3	14,6	12,3	10,1	7,1
5SV12..4	0,25	0,34	22,2						21,1	20,9	20,5	19,8	18,8	15,6	12,6	8,7
5SV15..4	0,37	0,5	27,5						25,9	25,6	25,2	24,2	22,9	18,8	15,0	10,1
5SV18..4	0,37	0,5	33,1						31,3	31,0	30,4	29,3	27,8	22,9	18,4	12,5
5SV21..4	0,37	0,5	38,4						36,1	35,7	35,0	33,6	31,7	26,0	20,7	13,7
5SV25..4	0,55	0,75	45,3						42,2	41,6	40,8	39,1	36,7	29,7	23,3	15,1
5SV28..4	0,55	0,75	51,7						49,1	48,6	47,8	46,1	43,7	36,2	29,2	20,0
5SV33..4	0,75	1	60,5						57,2	56,6	55,5	53,4	50,5	41,4	33,1	22,3

Hydraulic performances in compliance with ISO 9906:2012 - Grade 3B (ex ISO 9906:1999 - Annex A)

1-5sv-4p50-en_b_th

PUMP TYPE	RATED POWER		Q = DELIVERY														
			l/min 0	41,7	50	66,67	85	91,7	116,6	135	165	175	200	215	230	241,6	
	kW	HP	m ³ /h 0	2,5	3,0	4,0	5,1	5,5	7,0	8,1	9,9	10,5	12,0	12,9	13,8	14,5	
H = TOTAL HEAD IN METRES OF COLUMN OF WATER																	
10SV03..4	0,55	0,75	9,0	8,4	8,2	7,7	6,7	6,3	4,3								
10SV04..4	0,55	0,75	12,0	11,2	11,0	10,2	9,0	8,5	5,7								
10SV06..4	0,55	0,75	17,9	16,7	16,2	15,1	13,3	12,5	8,5								
10SV08..4	0,55	0,75	23,6	21,9	21,3	19,7	17,2	16,1	10,7								
10SV10..4	0,55	1	28,9	26,6	25,8	23,7	20,6	19,3	12,7								
10SV13..4	0,75	1	37,9	34,4	33,3	30,4	26,0	24,1	15,2								
10SV15..4	0,75	1,0	44,1	40,4	39,1	35,9	31,0	28,9	18,6								
10SV17..4	1,1	1,5	49,6	45,0	43,5	39,7	34,1	31,6	19,7								
10SV19..4	1,1	1,5	55,2	49,7	47,9	43,6	37,2	34,4	21,1								
10SV21..4	1,1	1,5	62,8	58,9	57,4	53,3	46,9	43,9	29,7								
15SV03..4	0,55	0,75	10,7			10,0	9,7	9,5	8,9	8,3	7,0	6,5	4,9				
15SV05..4	0,55	0,75	17,8			16,3	15,8	15,5	14,4	13,4	11,2	10,4	7,7				
15SV07..4	0,75	1,00	24,6			22,2	21,3	21,0	19,5	18,0	15,0	13,7	10,0				
15SV09..4	1,1	1,50	32,8			30,8	29,9	29,6	27,8	26,1	22,4	20,9	16,4				
15SV11..4	1,1	2	40,1			37,2	36,2	35,7	33,6	31,5	27,1	25,2	19,7				
15SV13..4	1,5	2	47,6			44,5	43,3	42,7	40,3	38,0	32,7	30,6	24,1				
15SV15..4	1,5	2,0	54,8			51,1	49,7	49,1	46,3	43,6	37,5	35,0	27,4				
15SV17..4	2,2	3	62,5			58,7	57,2	56,6	53,5	50,5	43,8	41,0	32,5				
22SV04..4	0,55	0,75	14,9						13,6	12,9	12,3	10,9	10,3	8,6	7,4	6,0	4,8
22SV06..4	1,1	1,5	22,6						20,8	19,8	18,9	16,9	16,0	13,6	11,9	9,9	8,2
22SV08..4	1,1	1,5	30,8						29,0	27,9	26,8	24,3	23,3	20,2	17,9	15,4	13,1
22SV10..4	1,5	2	38,6						36,5	35,2	33,8	30,8	29,5	25,7	22,9	19,7	17,0
22SV12..4	2,2	3	46,0						43,4	41,8	40,2	36,5	35,0	30,3	26,9	23,0	19,7
22SV14..4	2,2	3	53,9						51,4	49,6	47,8	43,6	41,8	36,5	32,6	28,1	24,2
22SV17..4	3	4	65,3						61,9	59,7	57,4	52,2	50,1	43,5	38,8	33,3	28,5

Hydraulic performances in compliance with ISO 9906:2012 - Grade 3B (ex ISO 9906:1999 - Annex A)

10-22sv-4p50-en_b_th

33, 46, 66, 92, 125SV SERIES

HYDRAULIC PERFORMANCE TABLE AT 50 Hz, 4-POLE

PUMP TYPE	RATED POWER		Q = DELIVERY															
			l/min 0	125	150	200	250	300	333	375	450	500	600	700	750	800	900	1000
			m ³ /h 0	7,5	9	12	15	18	20	22,5	27	30	36	42	45	48	54	60
kW		HP	H = TOTAL HEAD METRES COLUMN OF WATER															
33SV3/2A..4	1,1	1,5	14,4	13,7	13,4	12,4	10,9	9	7,3									
33SV4/1A..4	1,1	1,5	21,8	20,4	19,9	18,7	16,9	14,4	12,3									
33SV5..4	1,5	2	29,4	27,5	26,9	25,5	23,4	20,4	17,9									
33SV6..4	2,2	3	35,9	33,8	33,2	31,5	29	25,5	22,5									
33SV7..4	2,2	3	41,6	39,1	38,3	36,2	33,2	29,1	25,6									
33SV8..4	3	4	47,9	45,2	44,3	42	38,8	34,2	31,3									
33SV9..4	3	4	53,3	50,2	49,2	46,7	43	37,9	33,4									
33SV10..4	3	4	59	55,4	54	51	47	41,5	36,5									
33SV11..4	4	5,5	65,7	62,2	61	58	54	48	42,3									
33SV12..4	4	5,5	71,5	67,6	66	63	58	52	45,7									
33SV13..4	4	5,5	77,2	73	72	68	63	55	49									
46SV2..4	1,1	1,5	13			11,8	11,3	10,7	10,1	9,4	7,5	5,9						
46SV3..4	1,5	2	19,8			17,8	17,1	16,2	15,4	14,2	11,5	9,2						
46SV4..4	2,2	3	26,3			24	23,1	21,9	20,9	19,4	15,8	12,7						
46SV5..4	2,2	3	32,6			29,6	28,5	27	25,8	23,9	19,4	15,5						
46SV6..4	3	4	39,3			35,9	34,6	32,9	31,5	29,3	24,1	19,5						
46SV7..4	3	4	45,5			41,5	40	37,9	36,2	33,6	27,4	22						
46SV8..4	4	5,5	52,5			48,3	46,6	44,4	42,5	39,6	32,6	26,5						
46SV9..4	4	5,5	58,9			53,9	52	50	47,4	44,1	36,2	29,2						
46SV10..4	5,5	7,5	66,2			61	59	56	54	50,5	42	34,5						
46SV11..4	5,5	7,5	72,6			66,9	65	62	59	55,2	46	37,6						
46SV12..4	5,5	7,5	78,9			72,7	70	67	64	59,8	50	40,4						
66SV1..4	1,1	1,5	7,3			6,4	6,1	6	5,8	5,4	5,1	4,4	3,4	2,7				
66SV2..4	1,5	2	14,8			13,5	13,1	12,9	12,5	11,8	11,2	9,9	8,2	7,2				
66SV3..4	2,2	3	22,3			20,3	19,7	19,3	18,8	17,7	16,9	14,9	12,3	10,7				
66SV4..4	3	4	29,7			27,1	26,4	25,8	25,1	23,7	22,6	20	16,6	14,5				
66SV5..4	4	5,5	37,5			34,4	33,5	32,9	32	30,3	28,9	25,7	21,4	18,8				
66SV6..4	4	5,5	44,7			40,9	39,8	39	38	36	34,1	30,2	25,1	21,9				
66SV7..4	5,5	7,5	52,8			48,5	47,3	46	45	43	41	36	30,5	26,8				
66SV8..4	5,5	7,5	60,1			55,1	53,7	53	51	49	46	41	34,3	30,2				
92SV1..4	1,1	1,5	8,3						7	6,4	6,1	5,6	5,1	4,9	4,6	3,8	2,8	
92SV2..4	2,2	3	16,3						14,3	13,6	13,1	12,1	11,1	10,5	10	8,6	7	
92SV3..4	3	4	24,4						21,3	20,1	19,4	17,8	16,3	15,5	14,6	12,7	10,2	
92SV4..4	4	5,5	32,9						28,9	27,4	26,4	24,4	22,4	21,3	20,2	17,5	14,3	
92SV5..4	5,5	7,5	41,6						36,7	34,9	33,6	31,1	28,6	27,2	25,8	22,6	18,6	
92SV6..4	5,5	7,5	49,5						43,6	41	40	37	34	32,2	30,5	26,6	21,7	
92SV7..4	7,5	10	58						51,2	49	47	43	40	38	35,9	31,4	25,7	
92SV8..4	7,5	10	65,9						58	55	53	49	45	43	40,5	35,3	28,8	

Hydraulic performances in compliance with ISO 9906:2012 - Grade 3B (ex ISO 9906:1999 -)

33-92sv-4p50-en_b_th

PUMP TYPE	RATED POWER		Q = DELIVERY															
			l/min 0	250	300	375	450	500	600	708	850	950	1000	1075	1150	1333		
			m ³ /h 0	15,0	18,0	22,5	27,0	30,0	36,0	42,5	51,0	57,0	60,0	64,5	69,0	80,0		
kW		HP	H = TOTAL HEAD IN METRES OF COLUMN OF WATER															
125SV1..4	1,1	1,5	6,9					5,2	5,0	4,7	4,2	3,8	3,6	3,2	2,8	1,5		
125SV2..4	2,2	3	13,5					11,1	10,6	10,1	9,3	8,6	8,2	7,6	6,9	4,9		
125SV3/3B..4	2,2	3	17,5					14,1	13,4	12,6	11,2	10,1	9,5	8,4	7,2	3,6		
125SV4/4B..4	3	4	23,3					18,8	17,9	16,7	15,0	13,5	12,6	11,2	9,6	4,9		
125SV5/5A..4	4	5,5	31,4					25,6	24,4	23,0	20,9	19,2	18,2	16,5	14,7	9,2		
125SV6..4	5,5	7,5	40,4					33,3	31,9	30,3	27,8	25,8	24,7	22,8	20,8	14,7		
125SV7..4	7,5	10	47,1					38,8	37,2	35,3	32,5	30,1	28,8	26,7	24,2	17,2		
125SV8..4	7,5	10	53,8					44,4	42,5	40,4	37,1	34,4	32,9	30,5	27,7	19,6		

Hydraulic performances in compliance with ISO 9906:2012 - Grade 3B (ex ISO 9906:1999 - Annex A)

125sv-4p50-en_b_th

1SV SERIES DIMENSIONS AND WEIGHTS AT 50 Hz, 4-POLE

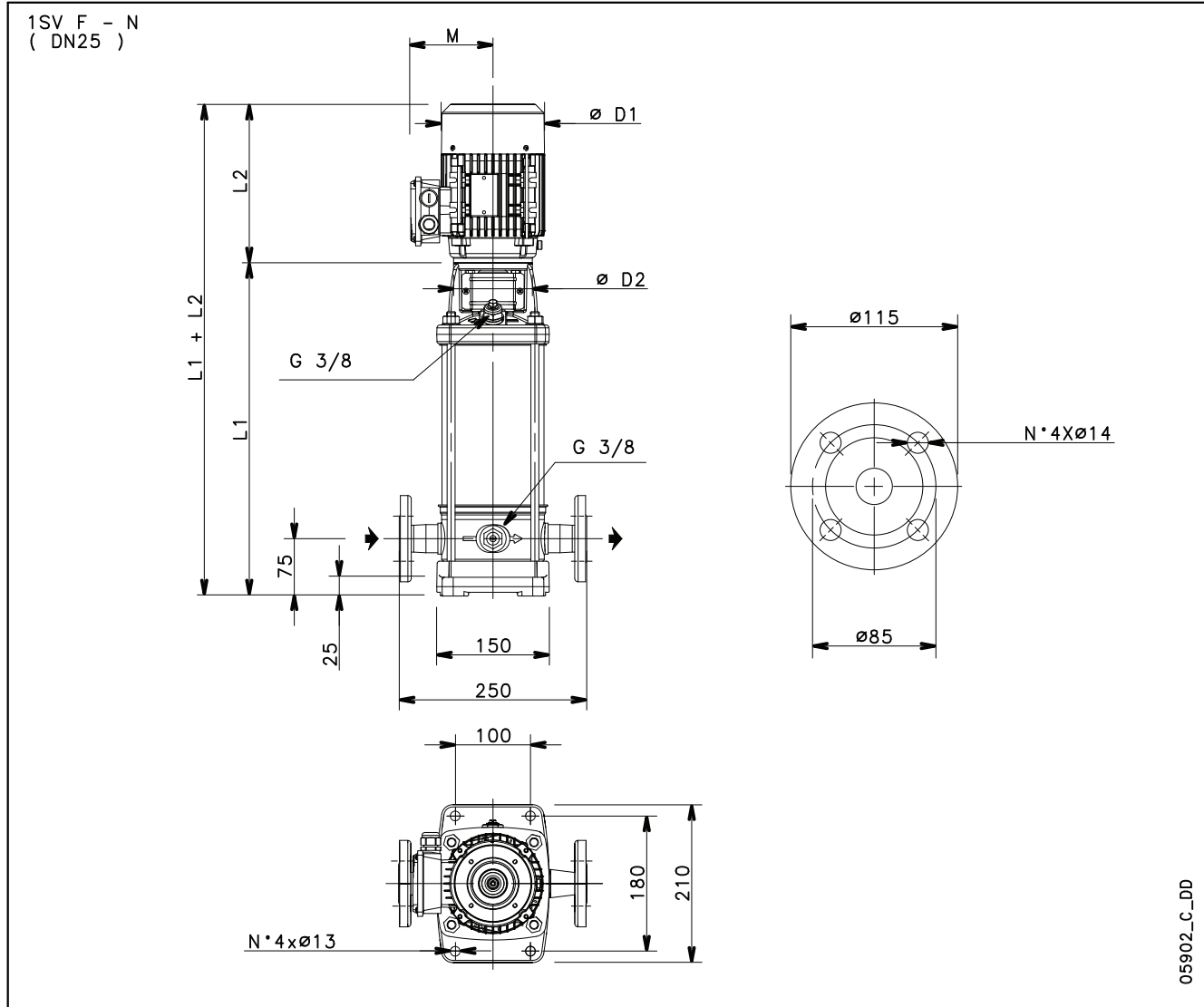

PUMP TYPE	MOTOR		DIMENSIONS (mm)					WEIGHT kg	
	kW	SIZE	L1	L2	D1	D2	M	PUMP	ELECTRIC PUMP
1SV02..4..	0,25	71	278	213	138	105	110	8,3	14
1SV05..4..	0,25	71	318	213	138	105	110	9,4	15,1
1SV08..4..	0,25	71	378	213	138	105	110	10,6	16,3
1SV11..4..	0,25	71	438	213	138	105	110	11,8	17,5
1SV15..4..	0,25	71	518	213	138	105	110	13,4	19,1
1SV19..4..	0,25	71	598	213	138	105	110	14,9	20,6
1SV22..4..	0,25	71	658	213	138	105	110	16,1	21,8
1SV27..4..	0,25	71	758	213	138	105	110	18,1	23,8
1SV30..4..	0,25	71	818	213	138	105	110	19,3	25
1SV34..4..	0,25	71	898	213	138	105	110	20,9	26,6
1SV37..4..	0,25	71	958	213	138	105	110	22,1	27,8

1sv-4p50-en_c_td

1SV SERIES
OPERATING CHARACTERISTICS AT 50 Hz, 4-POLE

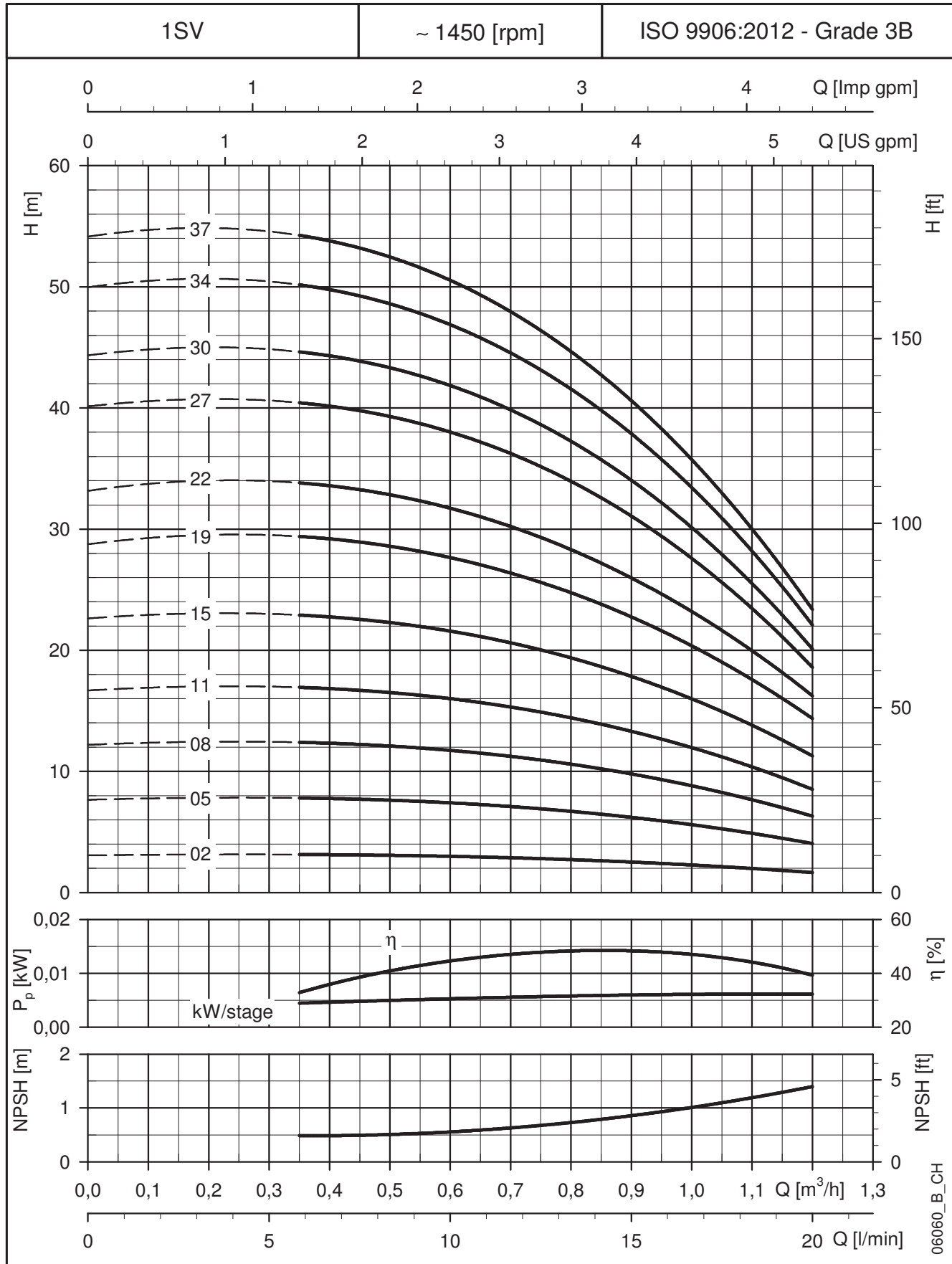

These performances are valid for liquids with density $\rho = 1.0 \text{ Kg/dm}^3$ and kinematic viscosity $\nu = 1 \text{ mm}^2/\text{sec}$.

3SV SERIES
DIMENSIONS AND WEIGHTS AT 50 Hz, 4-POLE

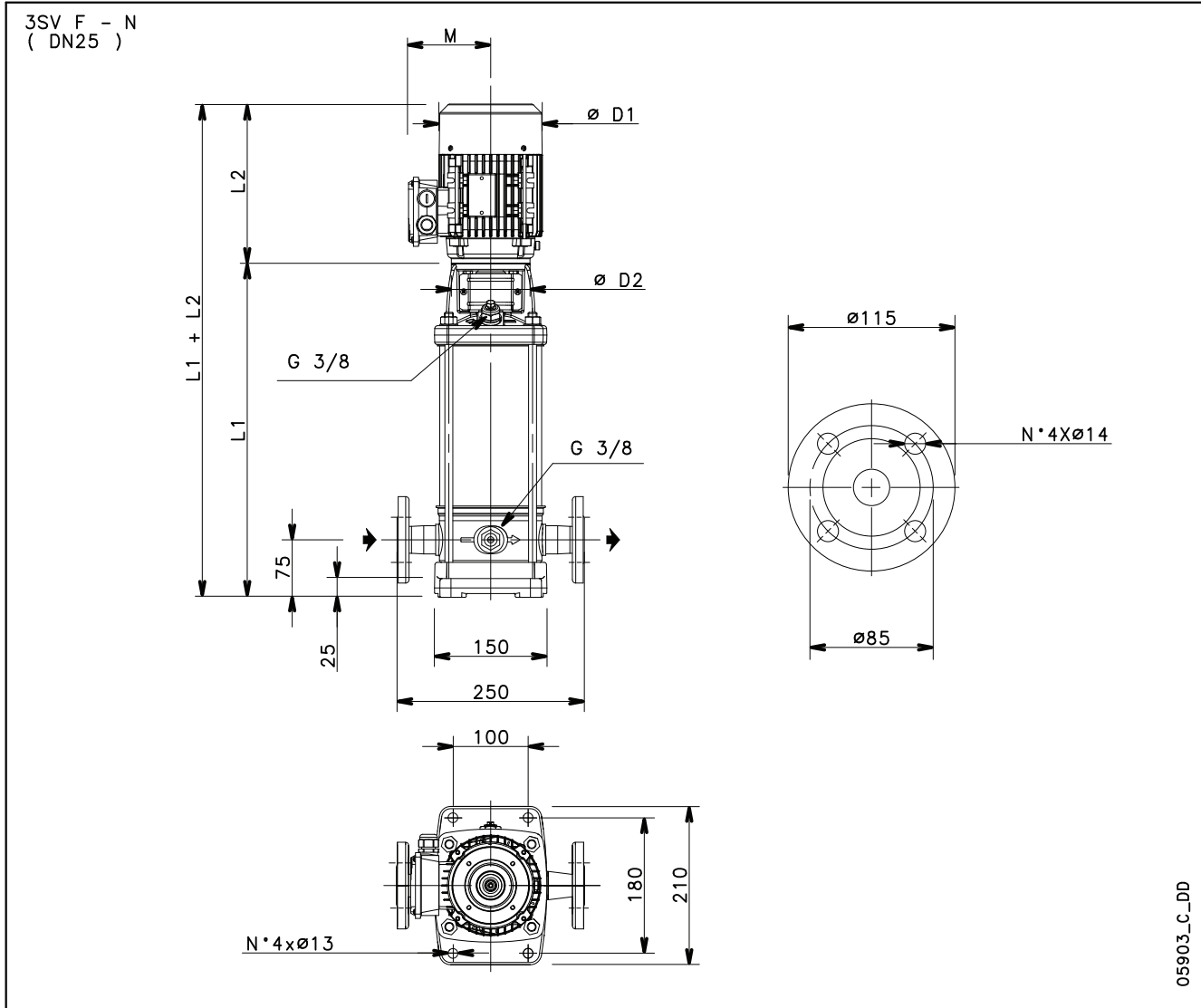

PUMP TYPE	MOTOR		DIMENSIONS (mm)					WEIGHT kg	
	kW	SIZE	L1	L2	D1	D2	M	PUMP	ELECTRIC PUMP
3SV02..4..	0,25	71	278	213	138	105	110	8	13,7
3SV05..4..	0,25	71	318	213	138	105	110	9,3	15
3SV08..4..	0,25	71	378	213	138	105	110	10,5	16,2
3SV11..4..	0,25	71	438	213	138	105	110	11,6	17,3
3SV14..4..	0,25	71	498	213	138	105	110	12,9	18,6
3SV19..4..	0,25	71	598	213	138	105	110	14,9	20,6
3SV23..4..	0,25	71	678	213	138	105	110	16,5	22,2
3SV27..4..	0,37	71	758	213	138	105	110	18	23,7
3SV33..4..	0,37	71	878	213	138	105	110	20,4	26,1

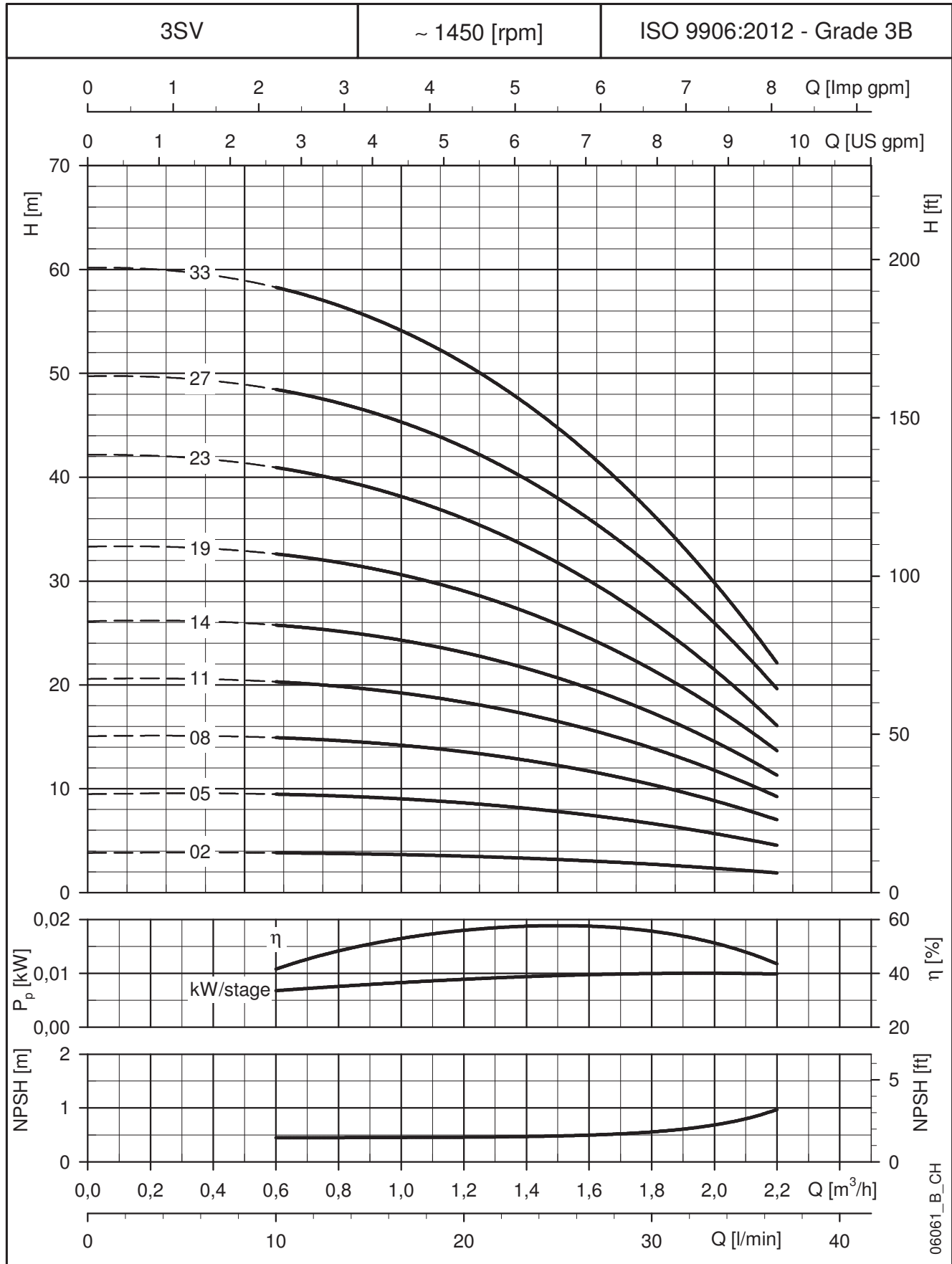
**3SV SERIES
OPERATING CHARACTERISTICS AT 50 Hz, 4-POLE**

These performances are valid for liquids with density $\rho = 1.0 \text{ Kg/dm}^3$ and kinematic viscosity $\nu = 1 \text{ mm}^2/\text{sec}$.

5SV SERIES
DIMENSIONS AND WEIGHTS AT 50 Hz, 4-POLE

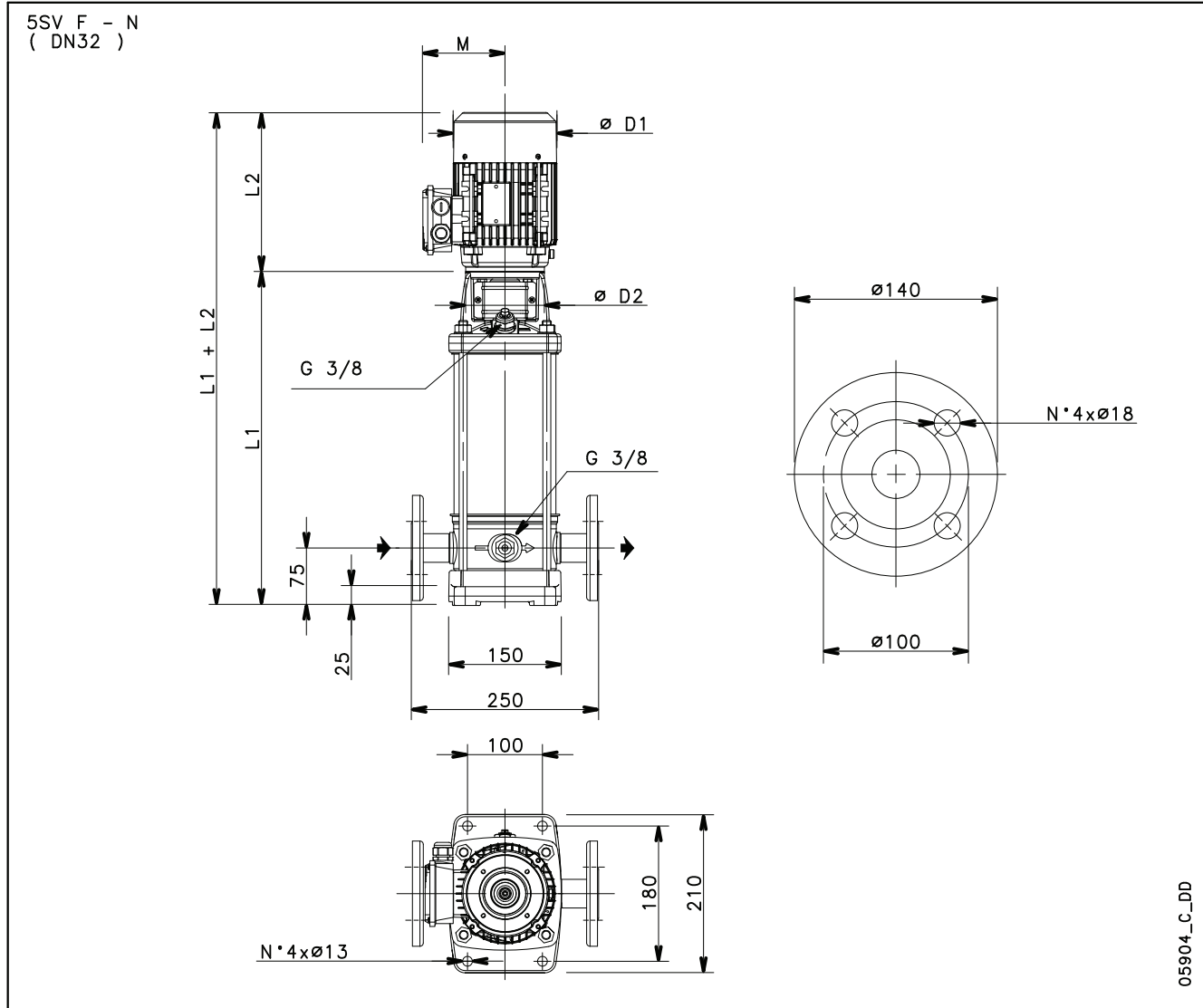

05904_C_DD

PUMP TYPE	MOTOR		DIMENSIONS (mm)					WEIGHT kg	
	kW	SIZE	L1	L2	D1	D2	M	PUMP	ELECTRIC
5SV03..4..	0,25	71	293	213	138	105	110	8,9	14,6
5SV06..4..	0,25	71	368	213	138	105	110	10,4	16,1
5SV09..4..	0,25	71	443	213	138	105	110	11,8	17,5
5SV12..4..	0,25	71	518	213	138	105	110	13,2	18,9
5SV15..4..	0,37	71	593	213	138	105	110	14,6	20,6
5SV18..4..	0,37	71	668	213	138	105	110	16	22
5SV21..4..	0,37	71	743	213	138	105	110	17,5	23,5
5SV25..4..	0,55	80	853	231	159	120	128	20	28,2
5SV28..4..	0,55	80	928	231	159	120	128	21,4	29,6
5SV33..4..	0,75	80	1053	231	159	120	128	23,8	36

5sv-4p50-en_d_td

5SV SERIES
OPERATING CHARACTERISTICS AT 50 Hz, 4-POLE

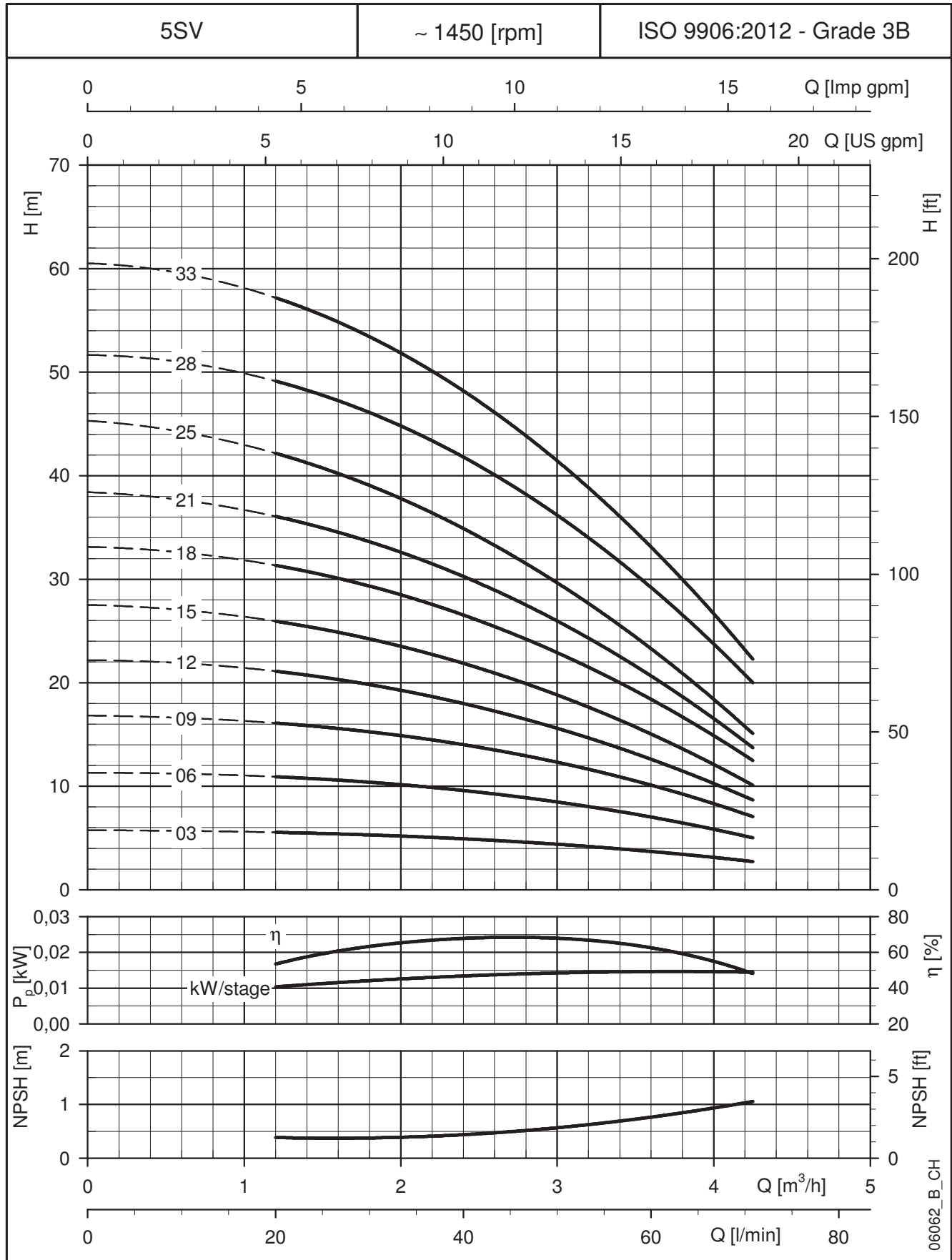

These performances are valid for liquids with density $\rho = 1.0 \text{ Kg/dm}^3$ and kinematic viscosity $\nu = 1 \text{ mm}^2/\text{sec}$.

10SV SERIES DIMENSIONS AND WEIGHTS AT 50 Hz, 4-POLE

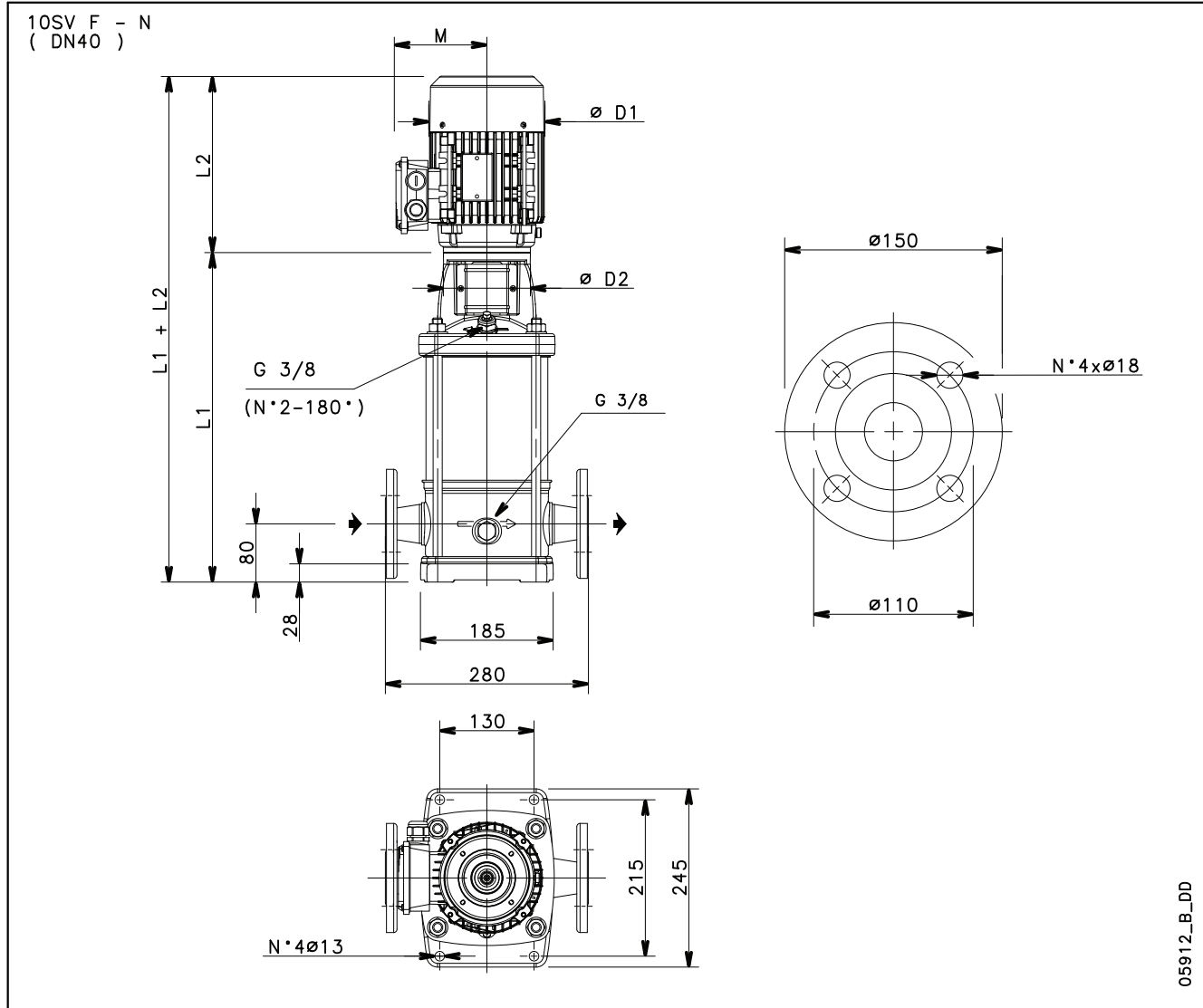

05912_B_DD

PUMP TYPE	MOTOR		DIMENSIONS (mm)					WEIGHT kg	
	kW	SIZE	L1	L2	D1	D2	M	PUMP	ELECTRIC PUMP
10SV03..4..	0,55	80	389	231	159	120	128	16,2	24,4
10SV04..4..	0,55	80	421	231	159	120	128	17,1	25,3
10SV06..4..	0,55	80	485	231	159	120	128	18,9	27,1
10SV08..4..	0,55	80	549	231	159	120	128	20,8	29
10SV10..4..	0,55	80	613	231	159	120	128	22,7	30,9
10SV13..4..	0,75	80	709	231	159	120	128	25,5	37,6
10SV15..4..	0,75	80	773	231	159	120	128	27,4	39,5
10SV17..4..	1,1	90	847	298	174	140	134	29,8	47,2
10SV19..4..	1,1	90	911	298	174	140	134	31,6	49,1
10SV21..4..	1,1	90	975	298	174	140	134	33,5	50,9

10sv-4p50-en_e_td

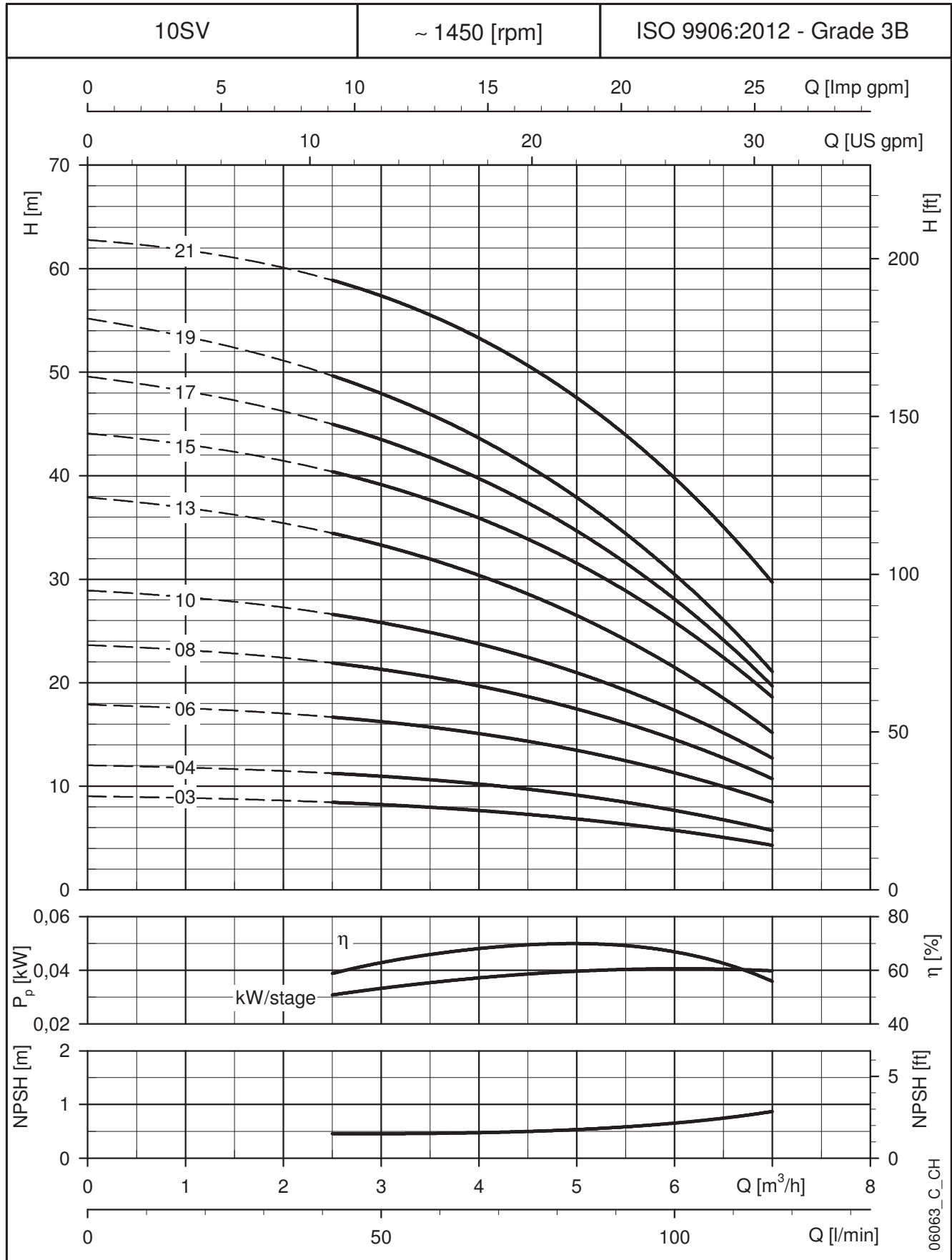
10SV SERIES
OPERATING CHARACTERISTICS AT 50 Hz, 4-POLE

These performances are valid for liquids with density $\rho = 1.0 \text{ Kg/dm}^3$ and kinematic viscosity $\nu = 1 \text{ mm}^2/\text{sec}$.

15SV SERIES

DIMENSIONS AND WEIGHTS AT 50 Hz, 4-POLE

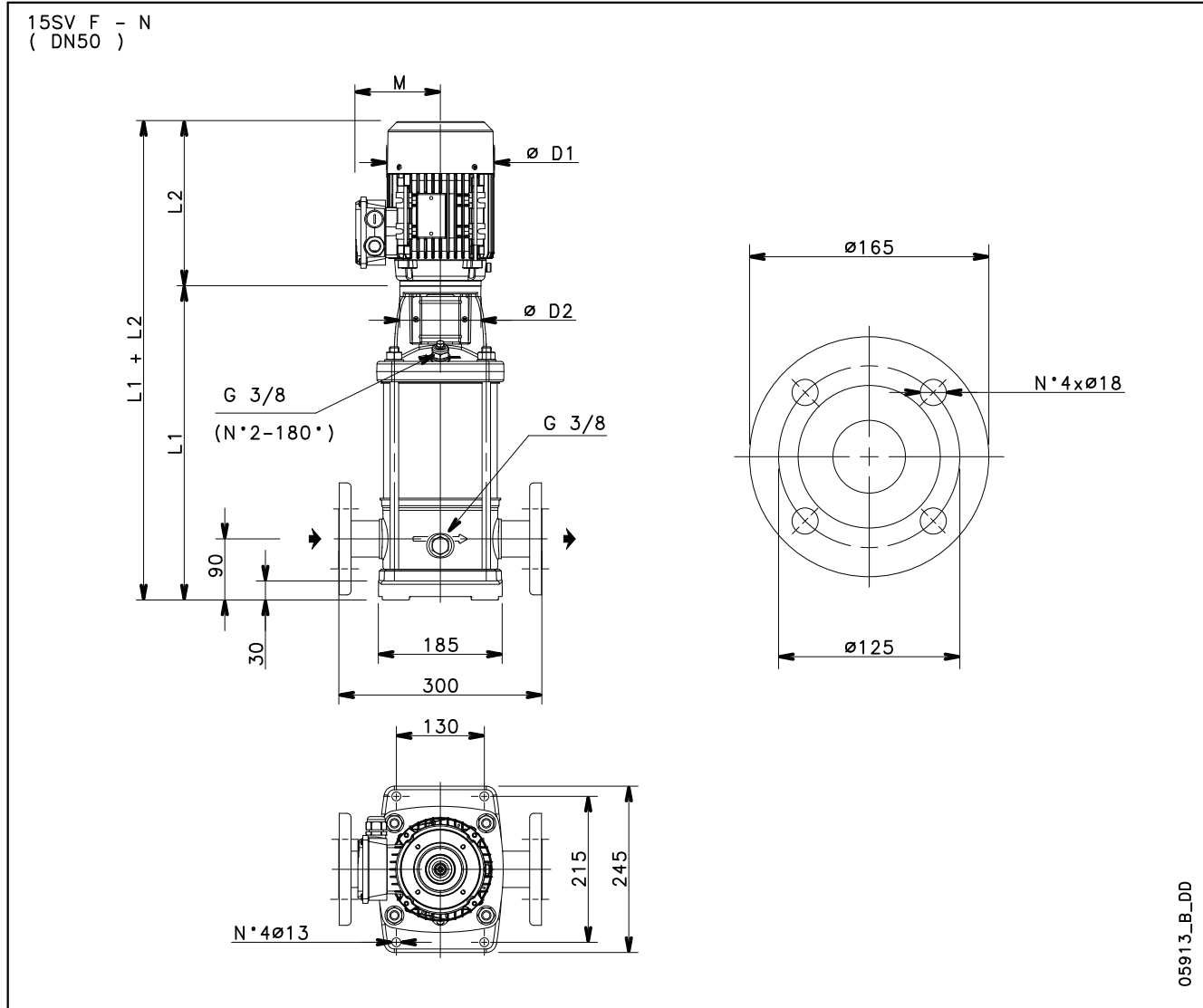

PUMP TYPE	MOTOR		DIMENSIONS (mm)					WEIGHT kg	
	kW	SIZE	L1	L2	D1	D2	M	PUMP	ELECTRIC PUMP
15SV03..4..	0,55	80	447	231	159	120	128	18,2	26,4
15SV05..4..	0,55	80	543	231	159	120	128	20,6	28,8
15SV07..4..	0,75	80	639	231	159	120	128	23,4	35,5
15SV09..4..	1,1	90	745	298	174	140	134	26,4	43,8
15SV11..4..	1,1	90	841	298	174	140	134	29,1	46,5
15SV13..4..	1,5	90	937	298	174	140	134	31,8	51,8
15SV15..4..	1,5	90	1033	298	174	140	134	34,4	54,4
15SV17..4..	2,2	100	1139	322	214	160	168	38	66,8

15sv-4p50-en_e_td

15SV SERIES
OPERATING CHARACTERISTICS AT 50 Hz, 4-POLE

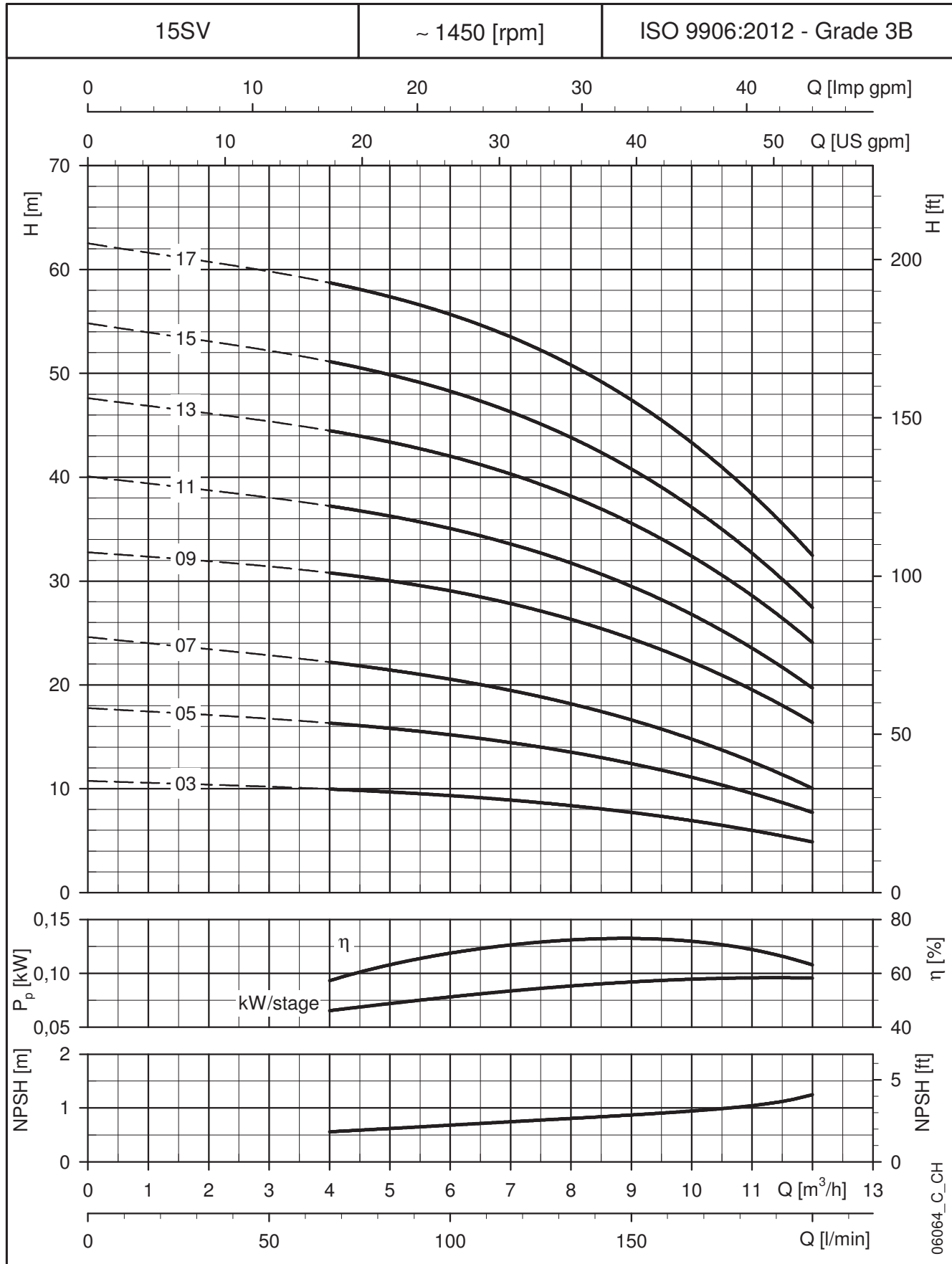

These performances are valid for liquids with density $\rho = 1.0 \text{ Kg/dm}^3$ and kinematic viscosity $\nu = 1 \text{ mm}^2/\text{sec}$.

22SV SERIES
DIMENSIONS AND WEIGHTS AT 50 Hz, 4-POLE

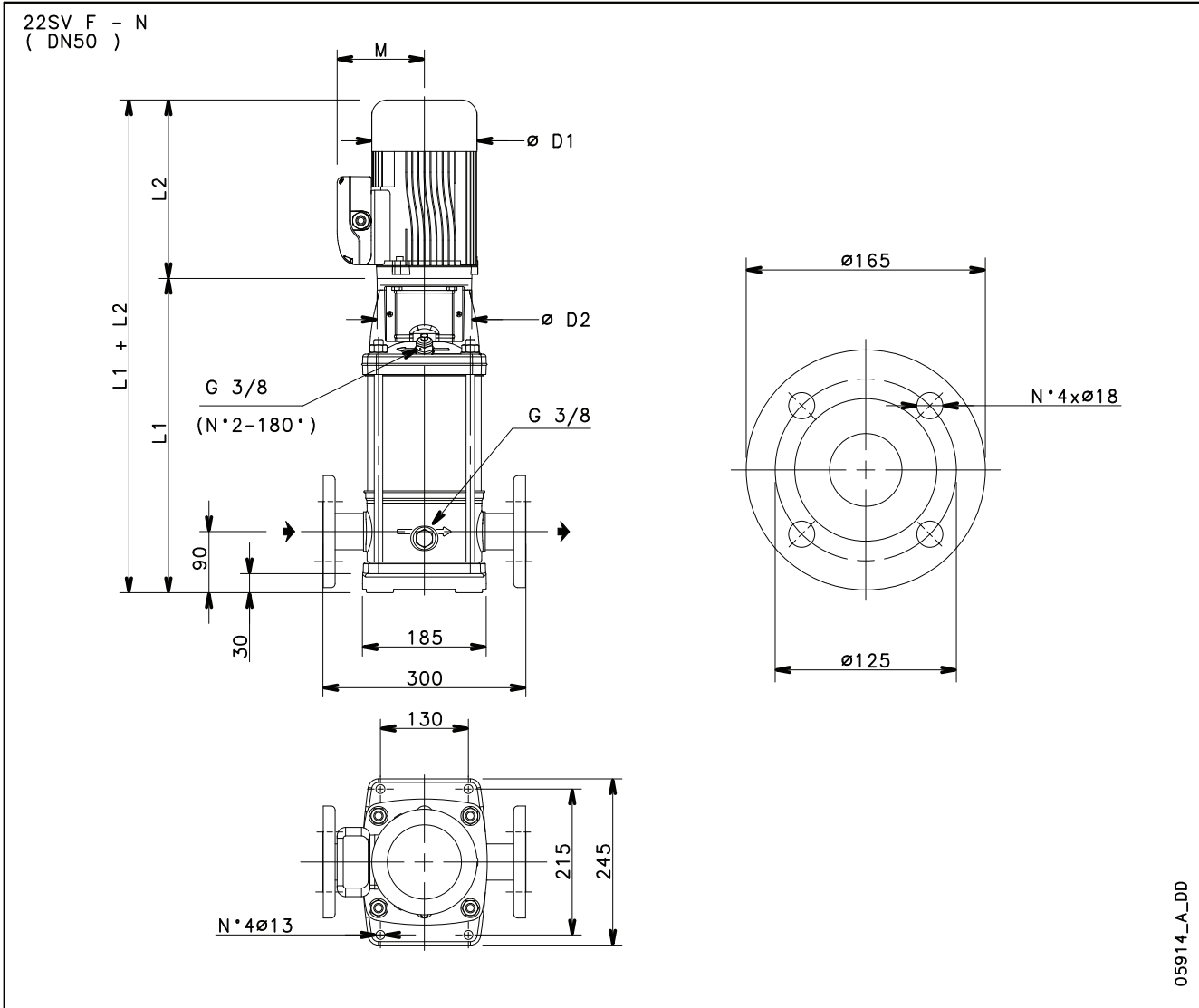

PUMP TYPE	MOTOR		DIMENSIONS (mm)					WEIGHT kg	
	kW	SIZE	L1	L2	D1	D2	M	PUMP	ELECTRIC PUMP
22SV04..4..	0,55	80	495	231	159	120	128	19,3	27,5
22SV06..4..	1,1	90	601	298	174	140	134	22,4	39,8
22SV08..4..	1,1	90	697	298	174	140	134	25,1	42,5
22SV10..4..	1,5	90	793	298	174	140	134	27,8	47,8
22SV12..4..	2,2	100	899	322	214	160	168	31,3	60,1
22SV14..4..	2,2	100	995	322	214	160	168	34	62,8
22SV17..4..	3	100	1139	353	214	160	168	38	70

22sv-4p50-en_c_td

22SV SERIES
OPERATING CHARACTERISTICS AT 50 Hz, 4-POLE

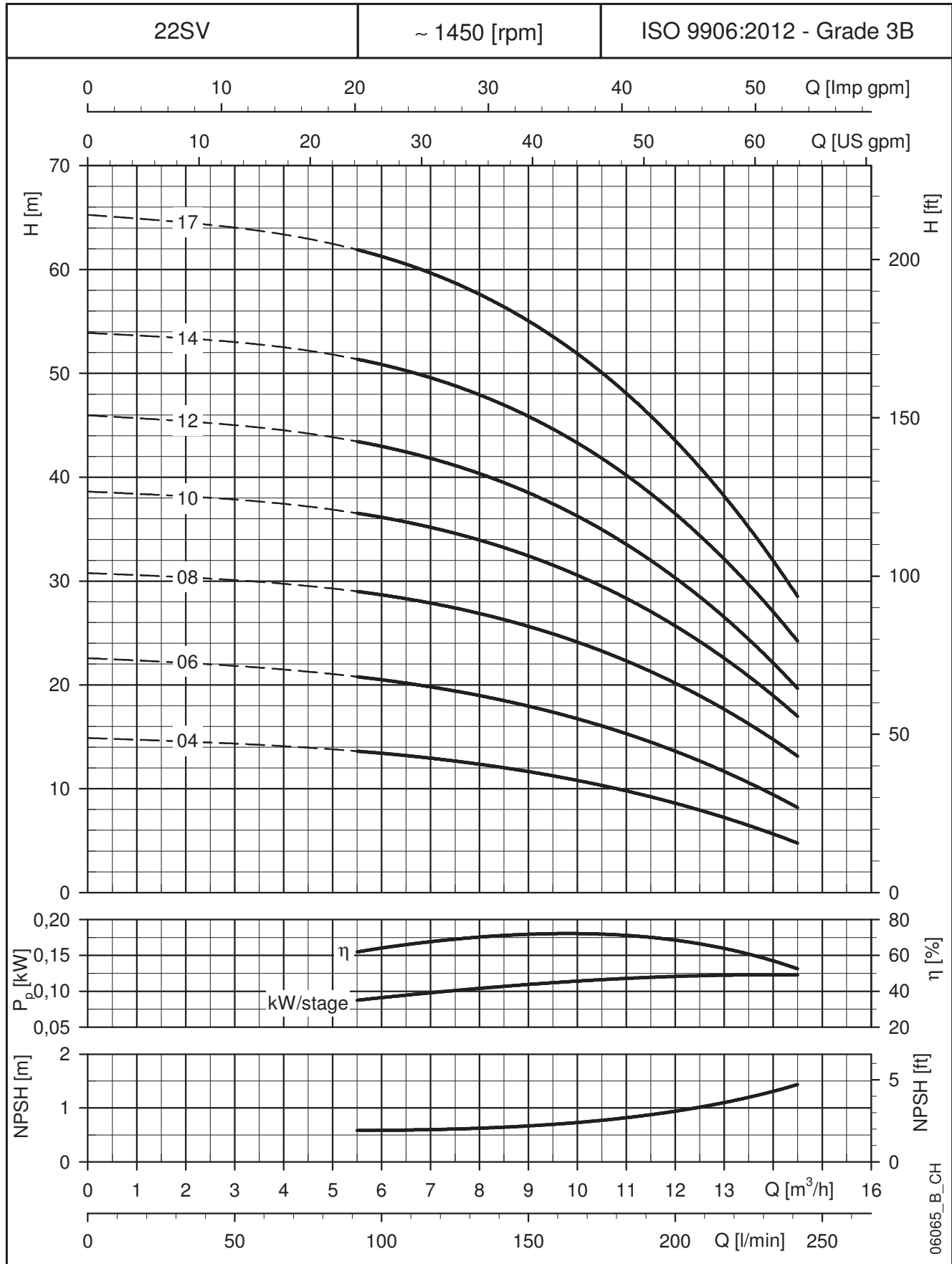

These performances are valid for liquids with density $\rho = 1.0 \text{ Kg/dm}^3$ and kinematic viscosity $\nu = 1 \text{ mm}^2/\text{sec}$.

33SV SERIES DIMENSIONS AND WEIGHTS AT 50 Hz, 4-POLE

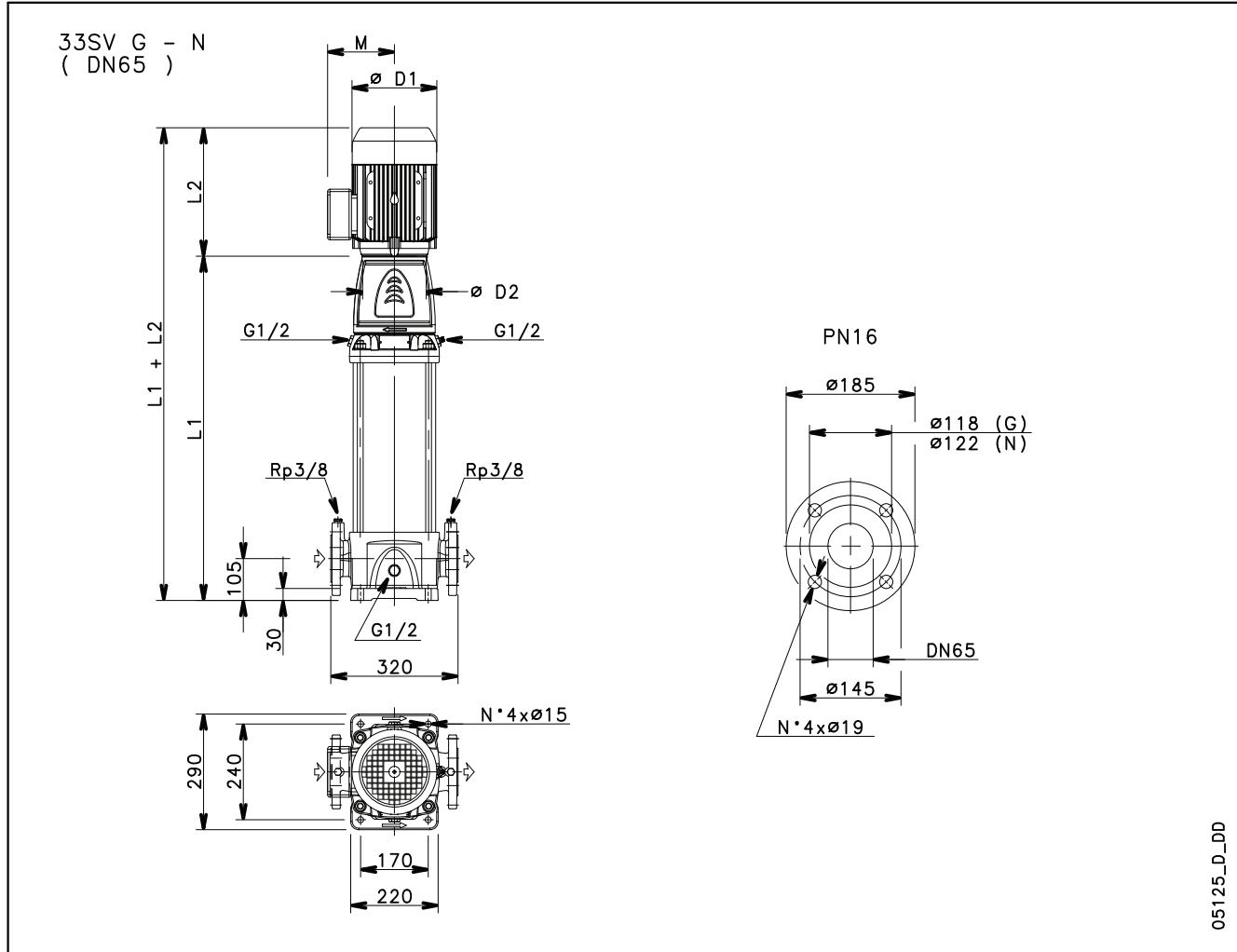

05125_D_DD

PUMP TYPE	MOTOR		DIMENSIONS (mm)						WEIGHT kg	
	kW	SIZE	L1	L2	D1	D2	M	PN	PUMP	ELECTRIC PUMP
33SV3/2A..4..	1,1	90	639	298	174	164	134	16	60	78
33SV4/1A..4..	1,1	90	714	298	174	164	134	16	64	82
33SV5..4..	1,5	90	789	298	174	164	134	16	68	91
33SV6..4..	2,2	100	864	322	214	164	168	16	72	101
33SV7..4..	2,2	100	939	322	214	164	168	16	75	104
33SV8..4..	3	100	1014	353	214	164	168	16	79	111
33SV9..4..	3	100	1089	353	214	164	168	16	83	115
33SV10..4..	3	100	1164	353	214	164	168	16	87	119
33SV11..4..	4	112	1239	398	214	164	168	16	96	150
33SV12..4..	4	112	1314	398	214	164	168	16	100	154
33SV13..4..	4	112	1389	398	214	164	168	16	103	157

33sv-4p50-en_b_td

33SV SERIES

OPERATING CHARACTERISTICS AT 50 Hz, 4-POLE

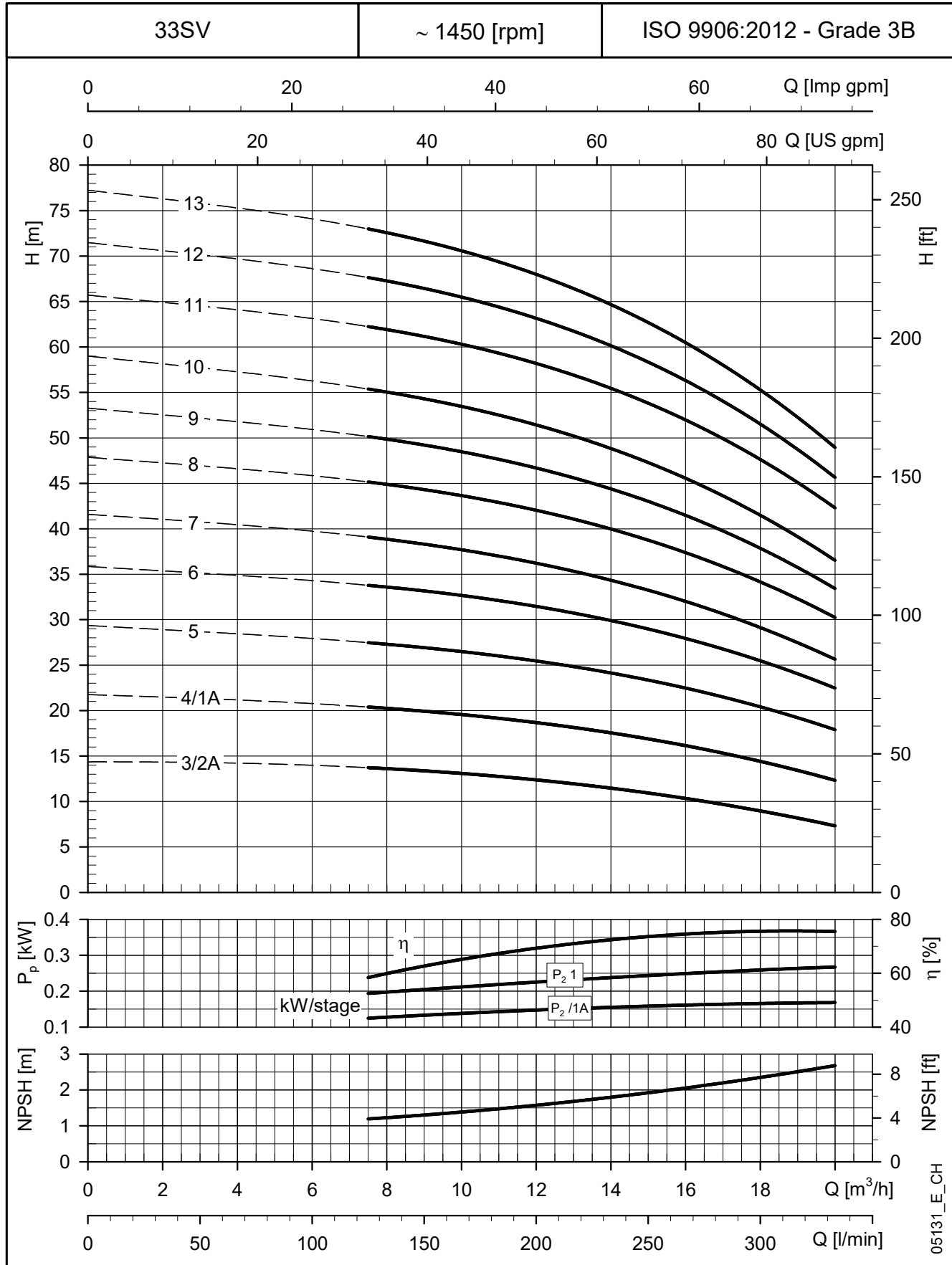

These performances are valid for liquids with density $\rho = 1.0 \text{ Kg/dm}^3$ and kinematic viscosity $\nu = 1 \text{ mm}^2/\text{sec}$.

46SV SERIES DIMENSIONS AND WEIGHTS AT 50 Hz, 4-POLE

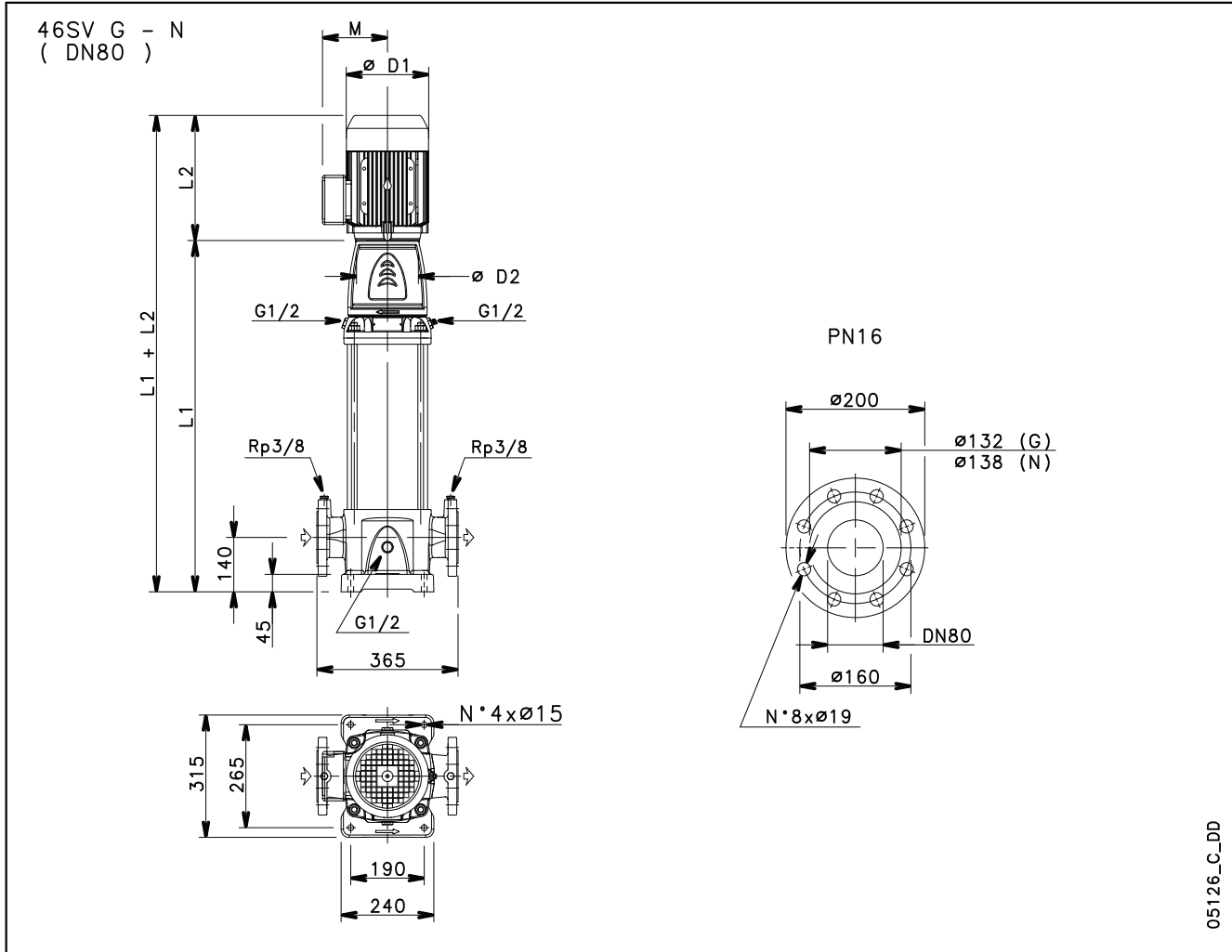

05126_C_DD

PUMP TYPE	MOTOR		DIMENSIONS (mm)						WEIGHT kg	
	kW	SIZE	L1	L2	D1	D2	M	PN	PUMP	ELECTRIC PUMP
46SV2..4..	1,1	90	604	298	174	164	134	16	61	79
46SV3..4..	1,5	90	679	298	174	164	134	16	65	88
46SV4..4..	2,2	100	754	322	214	164	168	16	69	98
46SV5..4..	2,2	100	829	322	214	164	168	16	73	102
46SV6..4..	3	100	904	353	214	164	168	16	77	109
46SV7..4..	3	100	979	353	214	164	168	16	80	112
46SV8..4..	4	112	1054	398	214	164	168	16	84	138
46SV9..4..	4	112	1129	398	214	164	168	16	88	142
46SV10..4..	5,5	132	1224	405	256	300	191	16	97	156
46SV11..4..	5,5	132	1299	405	256	300	191	16	105	164
46SV12..4..	5,5	132	1374	405	256	300	191	16	109	168

46sv-4p50-en_b_td

46SV SERIES
OPERATING CHARACTERISTICS AT 50 Hz, 4-POLE

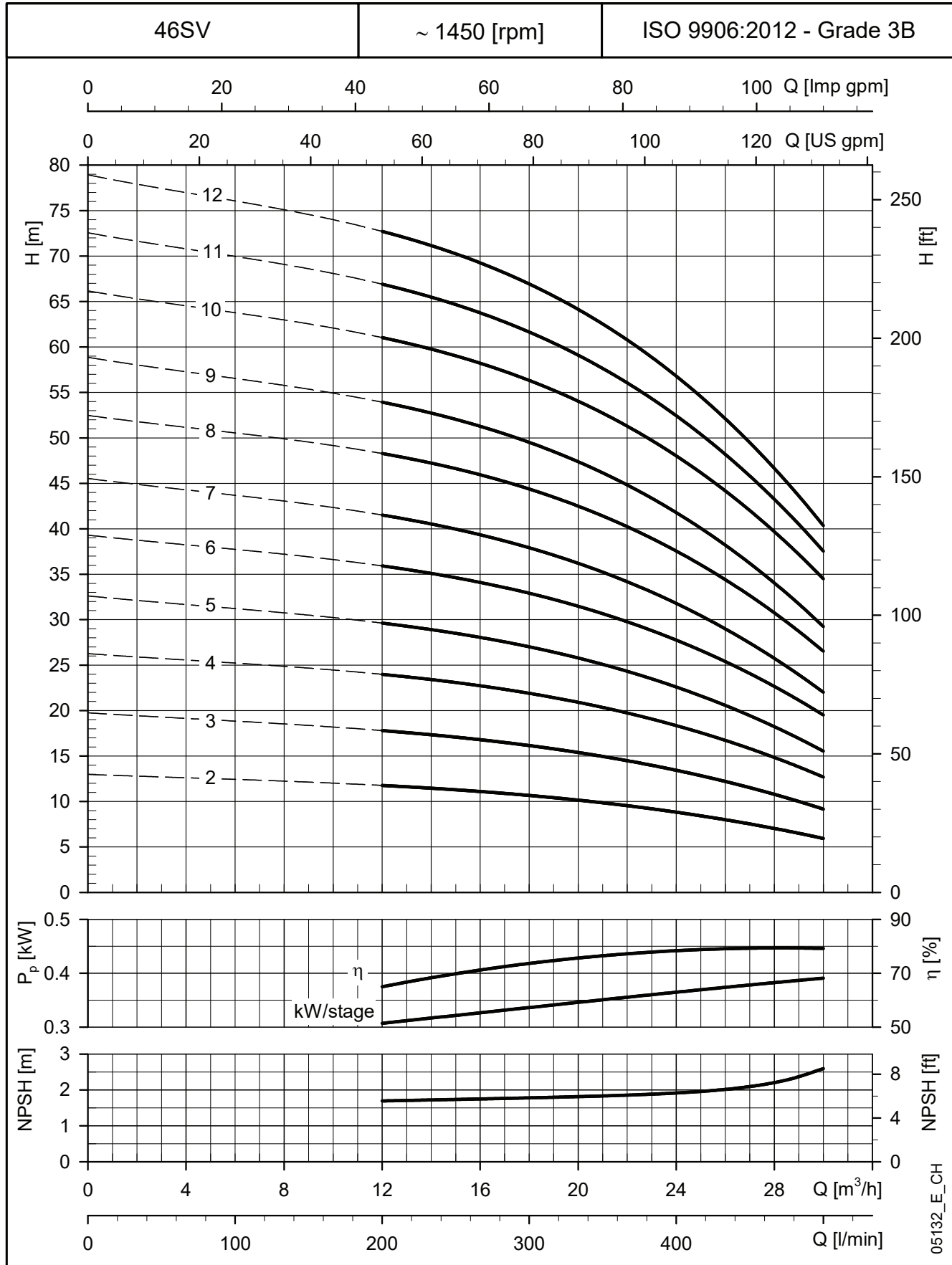

These performances are valid for liquids with density $\rho = 1.0 \text{ Kg/dm}^3$ and kinematic viscosity $\nu = 1 \text{ mm}^2/\text{sec}$.

66SV SERIES DIMENSIONS AND WEIGHTS AT 50 Hz, 4-POLE

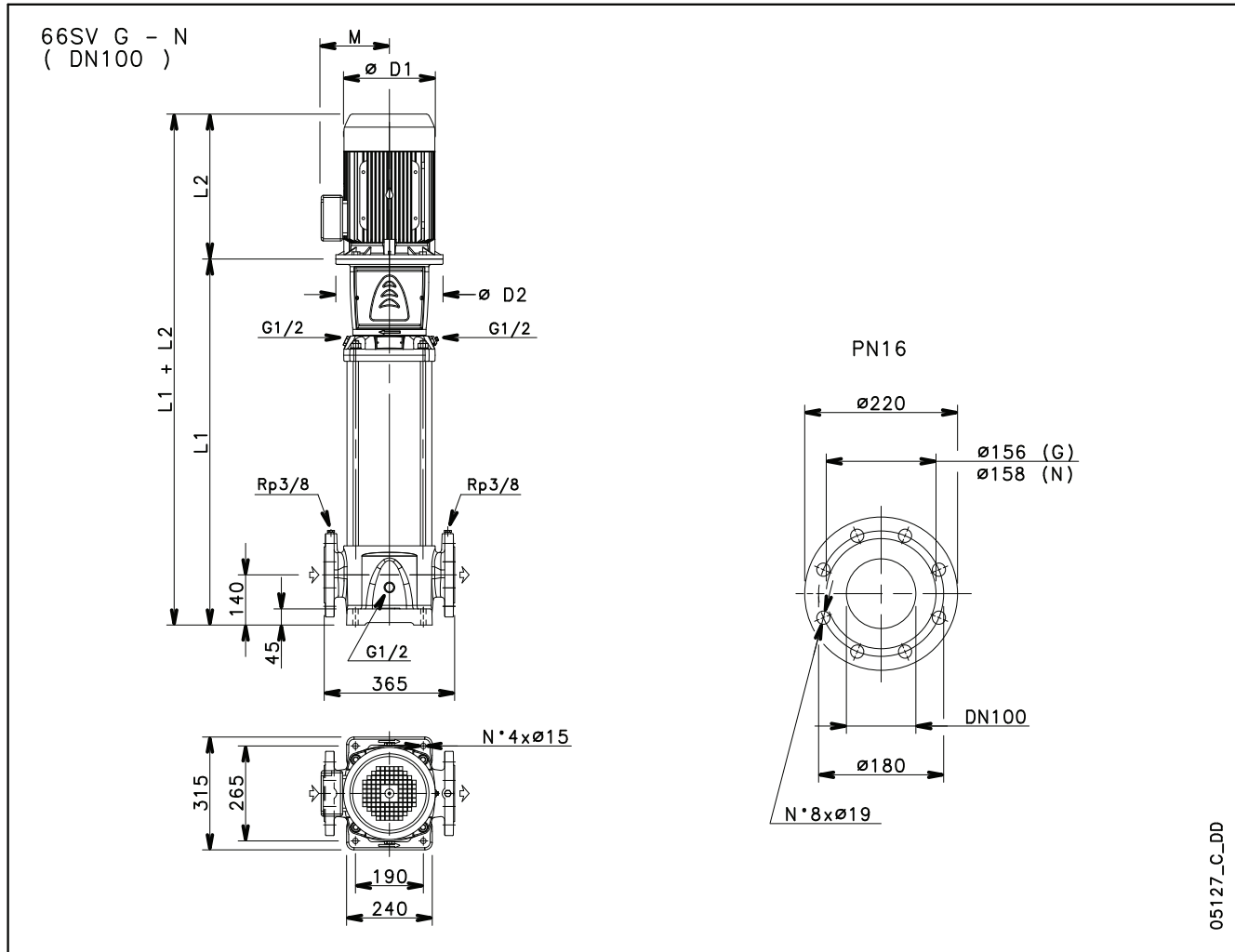

05127-C_DD

PUMP TYPE	MOTOR		DIMENSIONS (mm)						WEIGHT kg	
	kW	SIZE	L1	L2	D1	D2	M	PN	PUMP	ELECTRIC PUMP
66SV1..4..	1,1	90	554	298	174	164	134	16	66	84
66SV2..4..	1,5	90	644	298	174	164	134	16	72	95
66SV3..4..	2,2	100	734	322	214	164	168	16	77	106
66SV4..4..	3	100	824	353	214	164	168	16	82	114
66SV5..4..	4	112	914	398	214	164	168	16	87	141
66SV6..4..	4	112	1004	398	214	164	168	16	93	147
66SV7..4..	5,5	132	1114	405	256	300	191	16	103	166
66SV8..4..	5,5	132	1204	405	256	300	191	16	108	171

66sv-4p50-en_b_td

66SV SERIES
OPERATING CHARACTERISTICS AT 50 Hz, 4-POLE

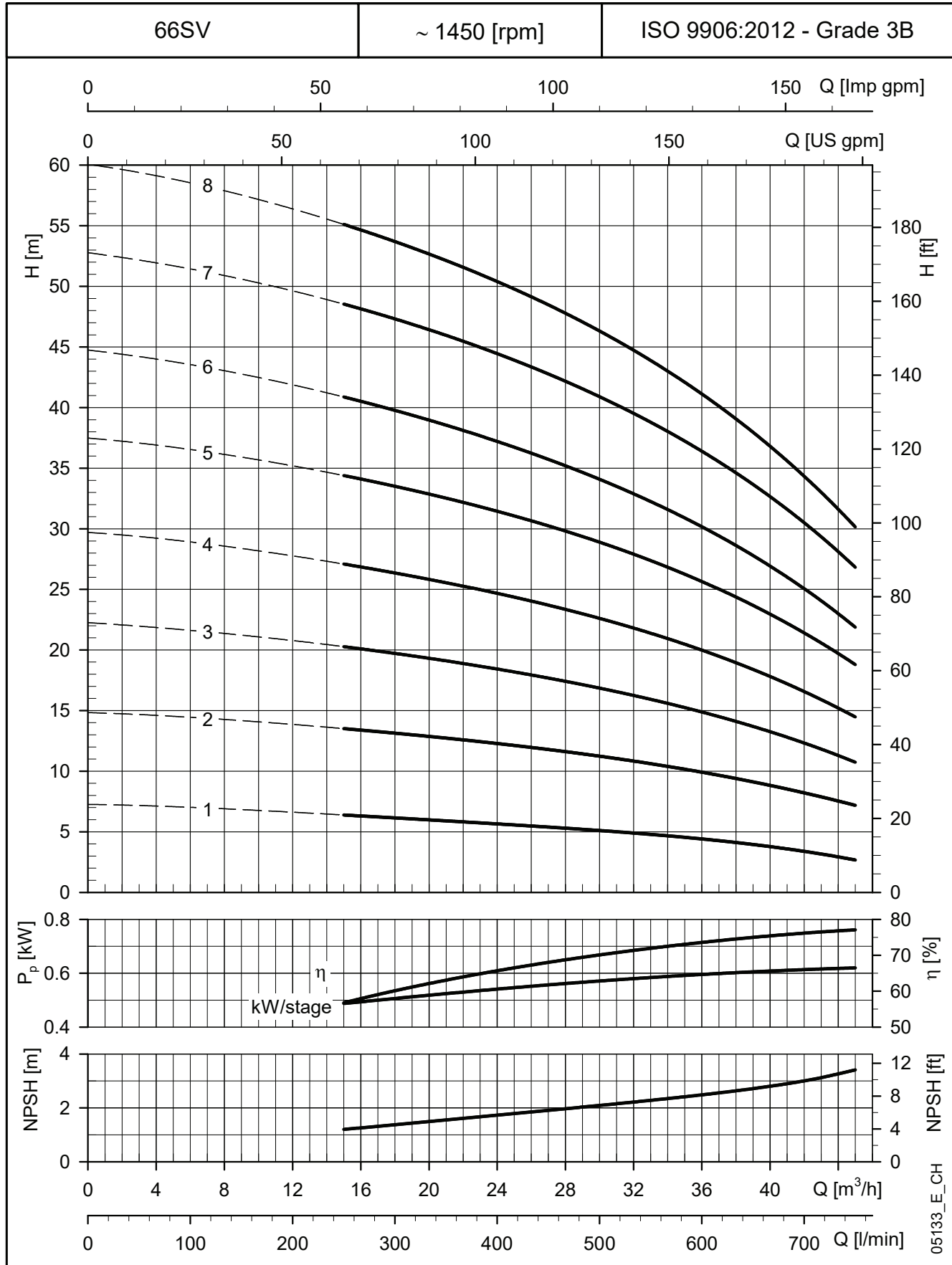

These performances are valid for liquids with density $\rho = 1.0 \text{ Kg/dm}^3$ and kinematic viscosity $\nu = 1 \text{ mm}^2/\text{sec}$.

92SV SERIES DIMENSIONS AND WEIGHTS AT 50 Hz, 4-POLE

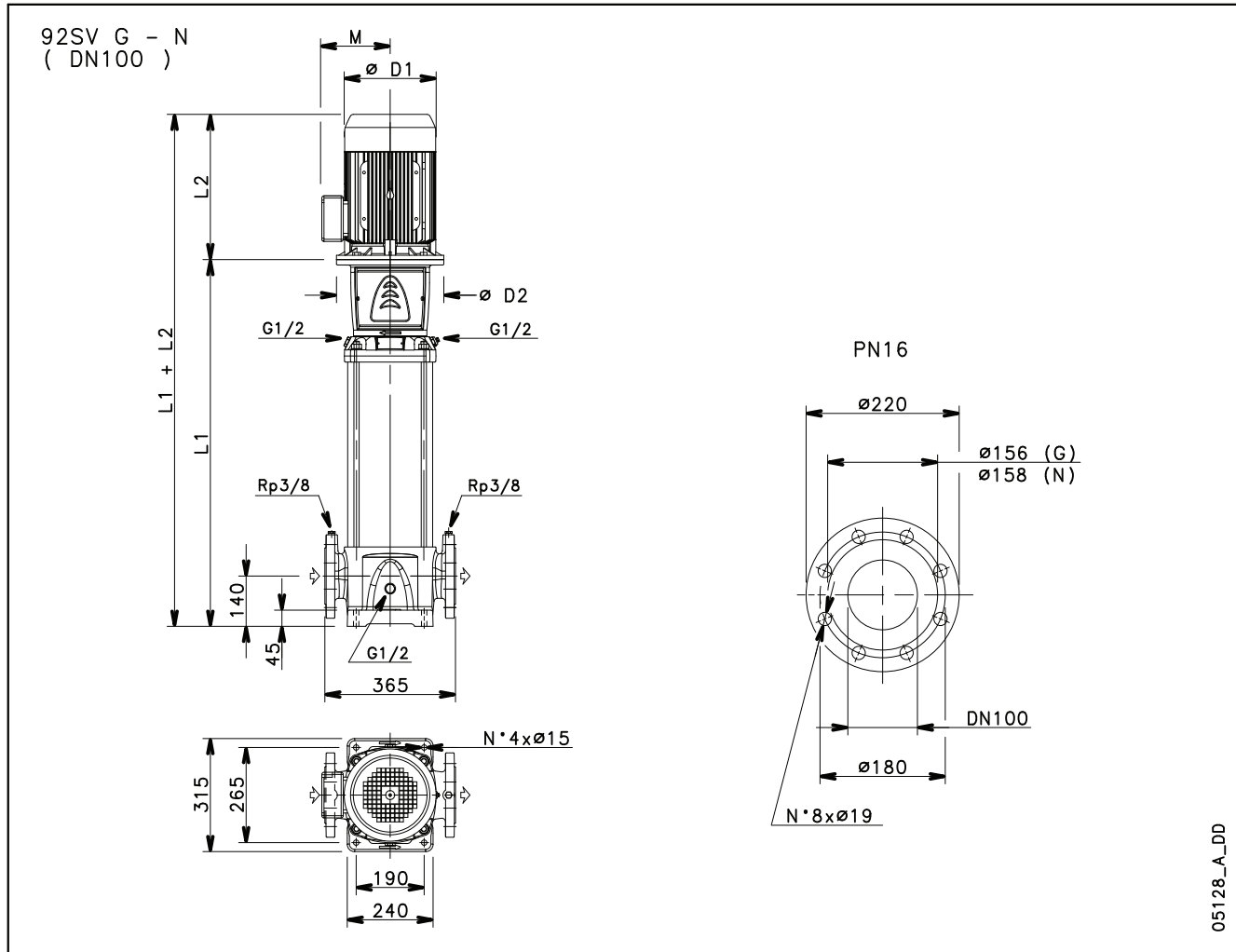

PUMP TYPE	MOTOR		DIMENSIONS (mm)						WEIGHT kg	
	kW	SIZE	L1	L2	D1	D2	M	PN	PUMP	ELECTRIC PUMP
92SV1..4..	1,1	90	554	298	174	164	134	16	66	84
92SV2..4..	2,2	100	644	322	214	164	168	16	71	100
92SV3..4..	3	100	734	353	214	164	168	16	77	109
92SV4..4..	4	112	824	398	214	164	168	16	82	136
92SV5..4..	5,5	132	934	405	256	300	191	16	91	154
92SV6..4..	5,5	132	1024	405	256	300	191	16	97	160
92SV7..4..	7,5	132	1114	405	256	300	191	16	102	169
92SV8..4..	7,5	132	1204	405	256	300	191	16	107	174

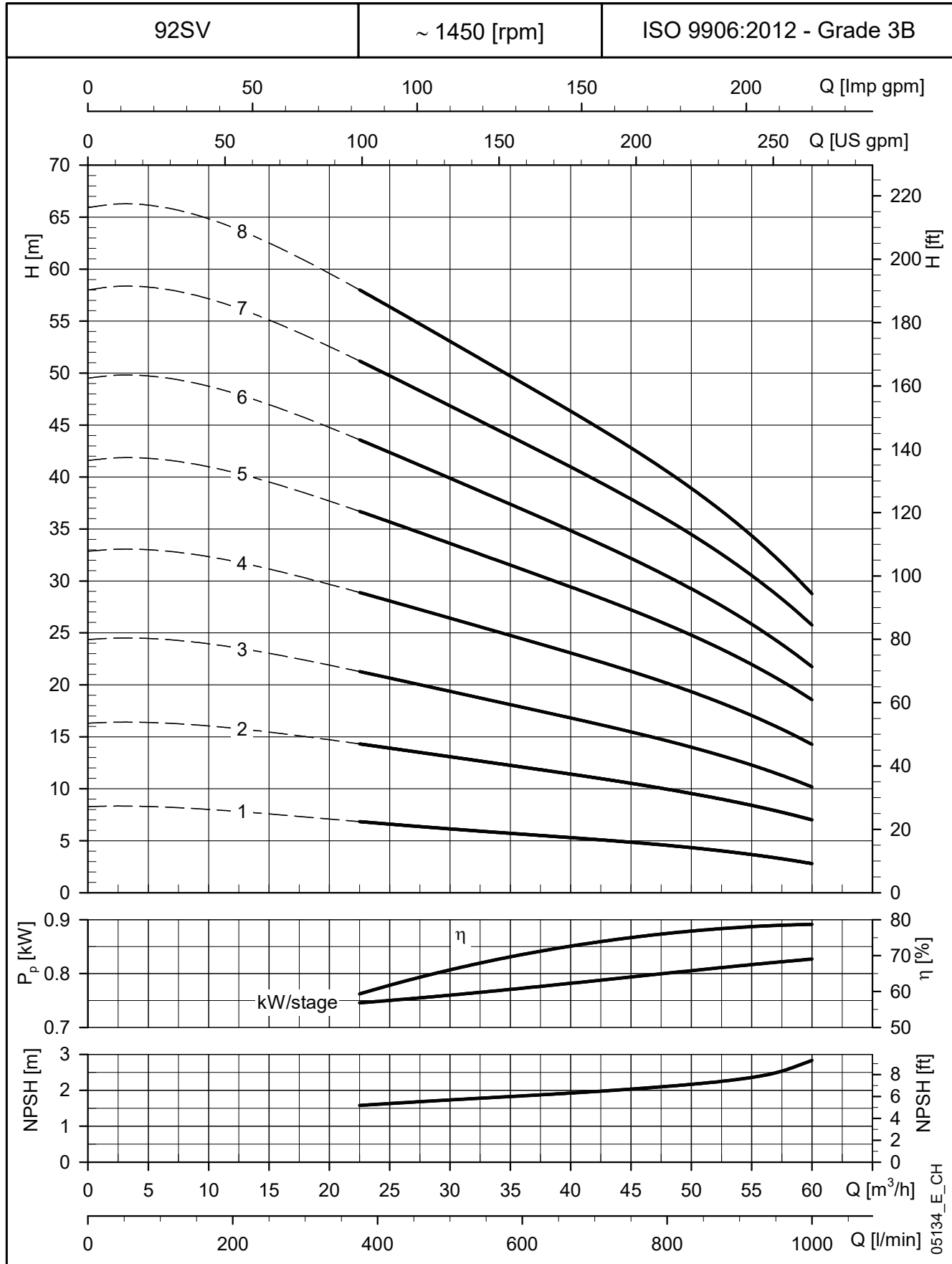
92SV SERIES
OPERATING CHARACTERISTICS AT 50 Hz, 4-POLE

These performances are valid for liquids with density $\rho = 1.0 \text{ Kg/dm}^3$ and kinematic viscosity $\nu = 1 \text{ mm}^2/\text{sec}$.

125SV SERIES DIMENSIONS AND WEIGHTS AT 50 Hz, 4-POLE

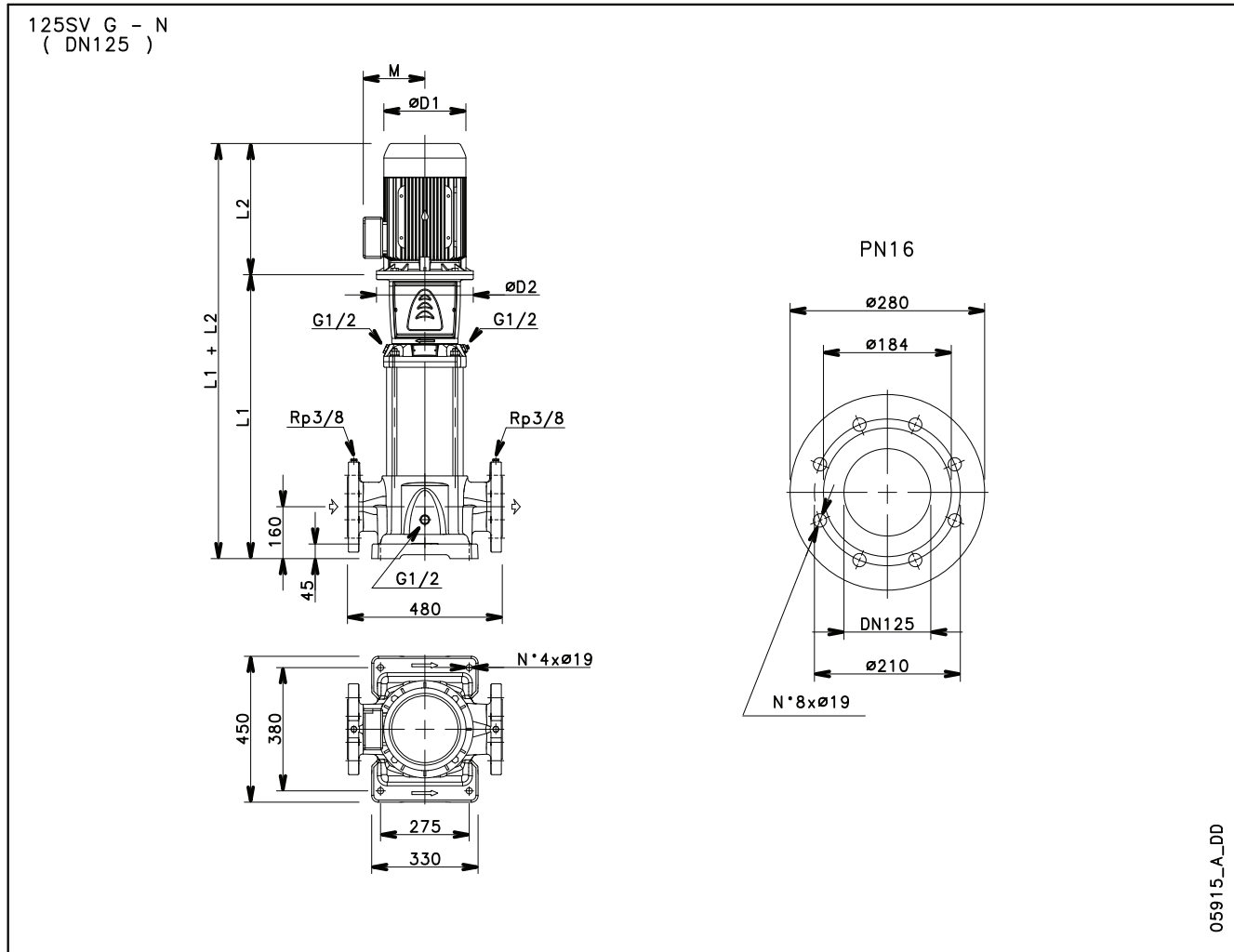

05915_A_DD

PUMP TYPE	MOTOR		DIMENSIONS (mm)						WEIGHT kg	
	kW	SIZE	L1	L2	D1	D2	M	PN	PUMP	ELECTRIC PUMP
125SV1..4..	1,1	90	673	298	174	140	134	16	110	128
125SV2..4..	2,2	100	823	322	214	160	168	16	121	150
125SV3/3B..4..	2,2	100	973	322	214	160	168	16	133	162
125SV4/4B..4..	3	100	1123	353	214	160	168	16	144	176
125SV5/5A..4..	4	112	1273	398	214	160	168	16	155	207
125SV6..4..	5,5	132	1443	405	256	300	191	16	172	234
125SV7..4..	7,5	132	1593	405	256	300	191	16	186	253
125SV8..4..	7,5	132	1743	405	256	300	191	16	199	265

125sv-4p50-en_b_td

125SV SERIES
OPERATING CHARACTERISTICS AT 50 Hz, 4-POLE

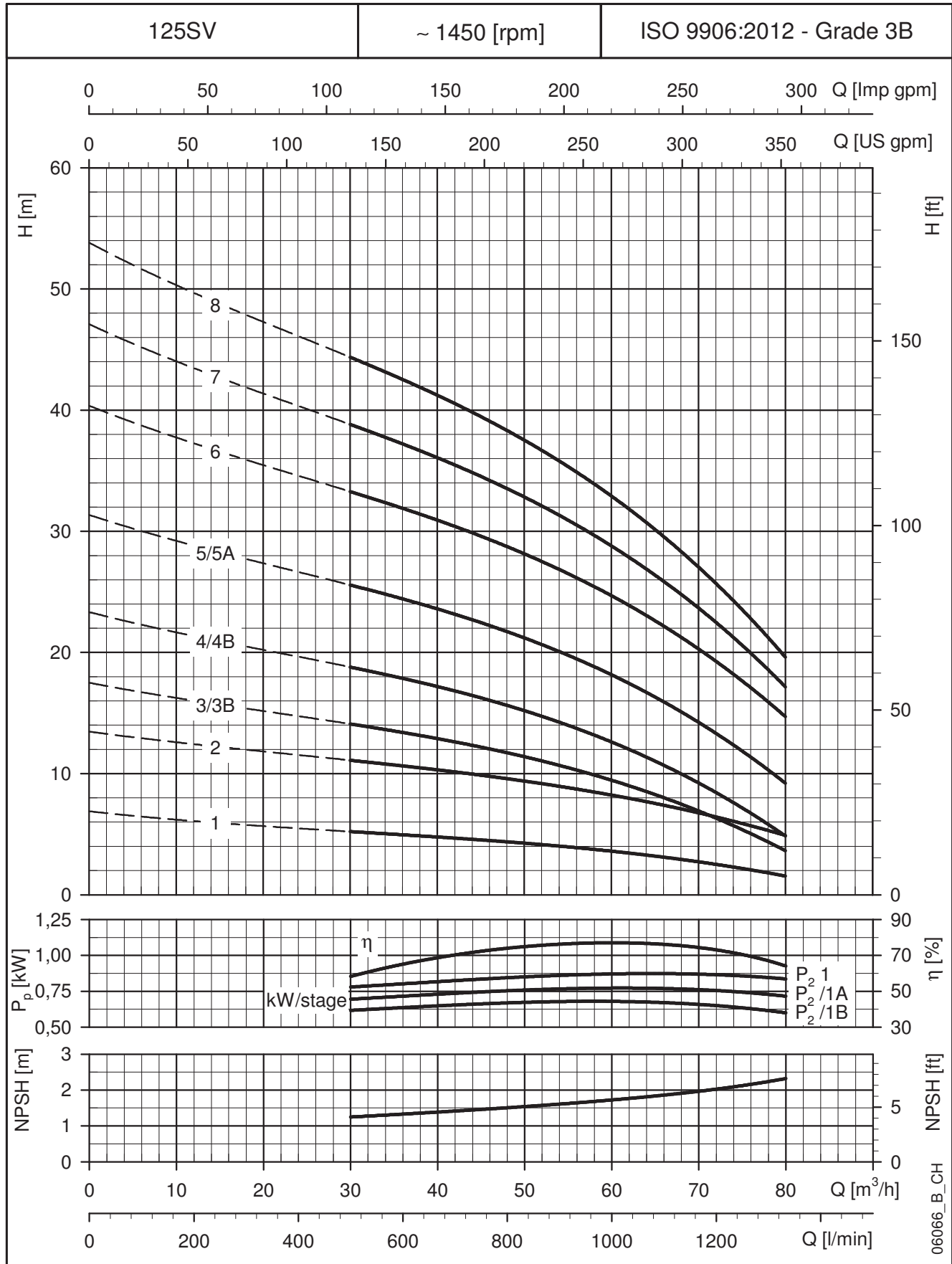

These performances are valid for liquids with density $\rho = 1.0 \text{ Kg/dm}^3$ and kinematic viscosity $\nu = 1 \text{ mm}^2/\text{sec}$.

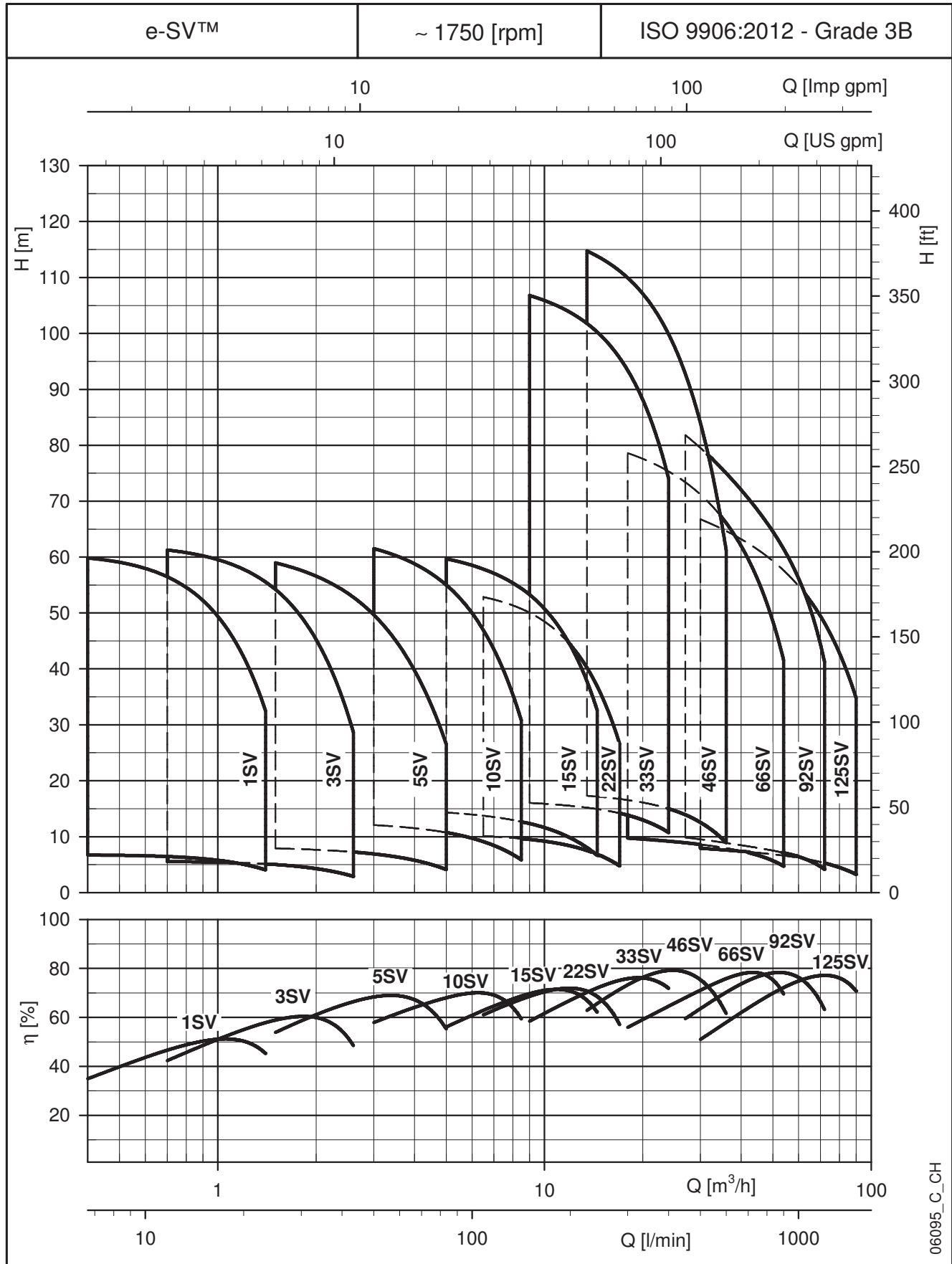
e-SV SERIES
HYDRAULIC PERFORMANCE RANGE AT 60 Hz, 4-POLE

06095_C_CH

1, 3, 5SV SERIES

HYDRAULIC PERFORMANCE TABLE AT 60 Hz, 4-POLE

PUMP TYPE	RATED POWER		Q = DELIVERY													
	kW	HP	l/min	6,7	10	11,7	15	18	23,33	25	30	35	43,3	50	60	83,33
			m ³ /h	0,4	0,6	0,7	0,9	1,1	1,4	1,5	1,8	2,1	2,6	3,0	3,6	5,0
H = TOTAL HEAD IN METRES OF COLUMN OF WATER																
1SV03..4	0,25	0,34	6,6	6,7	6,6	6,4	6,1	5,5	4,1							
1SV05..4	0,25	0,34	11,0	11,1	10,9	10,7	10,0	9,1	6,6							
1SV07..4	0,25	0,34	15,3	15,5	15,2	14,8	13,9	12,6	9,2							
1SV09..4	0,25	0,34	19,6	19,8	19,4	18,9	17,7	16,0	11,6							
1SV11..4	0,25	0,34	23,9	24,1	23,5	23,0	21,4	19,3	13,9							
1SV13..4	0,25	0,34	28,2	28,3	27,6	26,9	25,1	22,6	16,1							
1SV15..4	0,25	0,34	32,4	32,5	31,6	30,9	28,6	25,8	18,3							
1SV17..4	0,25	0,34	36,6	36,7	35,6	34,7	32,2	28,9	20,4							
1SV18..4	0,25	0,34	38,7	38,7	37,6	36,6	33,9	30,4	21,4							
1SV20..4	0,25	0,34	42,9	42,8	41,5	40,4	37,4	33,5	23,3							
1SV22..4	0,25	0,34	47,0	46,8	45,3	44,1	40,7	36,4	25,3							
1SV24..4	0,25	0,34	51,1	50,8	49,1	47,7	44,0	39,2	27,0							
1SV26..4	0,37	0,5	55,2	54,7	52,8	51,3	47,3	42,1	28,7							
1SV28..4	0,37	0,5	60,0	59,8	58,0	56,5	52,2	46,7	32,5							
3SV02..4	0,25	0,34	5,5			5,5	5,5	5,4	5,1	5,0	4,6	4,1	2,9			
3SV04..4	0,25	0,34	10,9			11,0	10,8	10,6	10,1	9,9	9,1	8,0	5,6			
3SV06..4	0,25	0,34	16,3			16,3	16,1	15,8	14,9	14,6	13,3	11,7	8,1			
3SV08..4	0,25	0,34	21,6			21,4	21,1	20,6	19,5	19,0	17,3	15,2	10,3			
3SV10..4	0,25	0,34	26,8			26,5	26,0	25,4	24,0	23,4	21,3	18,5	12,4			
3SV12..4	0,25	0,34	32,0			31,5	30,9	30,1	28,3	27,6	25,0	21,7	14,4			
3SV14..4	0,37	0,5	37,6			37,1	36,4	35,6	33,5	32,7	29,7	25,8	17,3			
3SV15..4	0,37	0,5	40,4			39,9	39,2	38,3	36,1	35,2	32,0	27,9	18,6			
3SV17..4	0,37	0,5	45,5			44,9	44,1	43,0	40,5	39,4	35,7	31,0	20,4			
3SV19..4	0,37	0,5	50,7			49,8	48,8	47,6	44,7	43,5	39,3	33,9	22,1			
3SV21..4	0,55	0,75	55,8			54,6	53,5	52,1	48,8	47,5	42,8	36,8	23,7			
3SV23..4	0,55	0,75	61,9			61,3	60,2	58,9	55,6	54,2	49,3	42,9	28,7			
5SV03..4	0,25	0,34	8,3							7,9	7,8	7,6	7,3	6,9	6,3	4,1
5SV05..4	0,25	0,34	13,7							13,0	12,7	12,4	11,8	11,2	10,1	6,5
5SV07..4	0,25	0,34	18,8							18,0	17,7	17,2	16,3	15,4	13,8	8,5
5SV09..4	0,37	0,5	24,0							22,8	22,3	21,7	20,5	19,3	17,1	10,3
5SV11..4	0,37	0,5	29,5							28,1	27,5	26,7	25,3	23,8	21,2	12,9
5SV13..4	0,55	0,75	34,7							32,7	31,9	30,9	29,0	27,2	24,0	14,1
5SV15..4	0,55	0,75	40,4							38,6	37,7	36,7	34,6	32,6	29,0	17,6
5SV17..4	0,55	0,75	45,6							43,4	42,4	41,2	38,8	36,5	32,4	19,4
5SV19..4	0,75	1	50,8							48,1	47,0	45,6	42,9	40,3	35,6	21,1
5SV21..4	0,75	1	56,7							54,1	52,9	51,5	48,6	45,8	40,7	24,8
5SV23..4	0,75	1	61,9							59,0	57,6	56,0	52,8	49,7	44,1	26,6

Hydraulic performances in compliance with ISO 9906:2012 - Grade 3B (ex ISO 9906:1999 - Annex A)

1-5sv-4p60-en_b_th

10, 15, 22SV SERIES
HYDRAULIC PERFORMANCE TABLE AT 60 Hz, 4-POLE

PUMP TYPE	RATED POWER		Q = DELIVERY													
	kW	HP	l/min 0	50	60	70	83,33	95	108,3	141,6	160	175	241,6	250	265	283,3
			m ³ /h 0	3,0	3,6	4,2	5,0	5,7	6,5	8,5	9,6	10,5	14,5	15,0	15,9	17,0
H = TOTAL HEAD IN METRES OF COLUMN OF WATER																
10SV03..4	0,55	0,75	13,0	12,1	11,8	11,4	10,7	10,1	9,1	5,9						
10SV05..4	0,55	0,75	21,6	20,0	19,4	18,8	17,7	16,6	15,0	9,4						
10SV07..4	0,75	1	29,9	27,2	26,4	25,5	23,9	22,2	19,9	12,1						
10SV09..4	0,75	1	38,5	35,4	34,4	33,2	31,2	29,1	26,3	16,4						
10SV11..4	1,1	1,5	47,8	44,9	43,8	42,5	40,3	37,9	34,5	22,8						
10SV13..4	1,1	1,5	56,2	52,8	51,5	49,8	47,1	44,1	40,0	26,0						
10SV15..4	1,5	2	65,1	61,5	60,0	58,1	55,0	51,6	46,9	30,8						
15SV03..4	0,55	0,75	15,4				14,3	14,1	13,7	12,7	11,9	11,2	6,7			
15SV04..4	0,75	1	20,6				19,2	18,9	18,4	17,0	16,0	15,1	9,0			
15SV05..4	1,1	1,5	26,2				24,7	24,4	23,9	22,3	21,1	20,0	12,7			
15SV06..4	1,1	1,5	31,3				29,5	29,1	28,5	26,5	25,1	23,7	14,9			
15SV07..4	1,5	2	36,7				34,7	34,2	33,5	31,3	29,7	28,1	17,8			
15SV08..4	1,5	2	42,4				39,6	39,1	38,4	36,0	34,3	32,6	21,5			
15SV09..4	2,2	3	48,0				45,2	44,6	43,8	41,3	39,4	37,5	25,1			
15SV10..4	2,2	3	53,3				50,0	49,4	48,5	45,7	43,6	41,5	27,7			
15SV11..4	2,2	3	58,5				54,9	54,2	53,2	50,1	47,7	45,4	30,2			
15SV12..4	2,2	3	63,8				59,7	58,9	57,9	54,4	51,8	49,3	32,6			
22SV02..4	0,55	0,75	11,0						10,1	9,7	9,3	9,0	6,9	6,5	5,8	4,8
22SV03..4	0,75	1	16,5						15,1	14,4	13,9	13,4	10,2	9,6	8,5	7,0
22SV04..4	1,1	1,5	22,2						21,1	20,3	19,7	19,0	14,8	14,0	12,6	10,6
22SV05..4	1,5	2	27,7						26,2	25,1	24,3	23,5	18,1	17,2	15,4	12,9
22SV06..4	1,5	2	33,3						31,7	30,4	29,5	28,5	22,1	21,0	18,9	15,9
22SV07..4	2,2	3	39,1						37,4	36,0	34,9	33,8	26,5	25,2	22,7	19,3
22SV08..4	2,2	3	44,6						42,6	40,9	39,7	38,4	30,0	28,6	25,7	21,8
22SV09..4	2,2	3	50,1						47,7	45,9	44,4	43,0	33,5	31,9	28,6	24,2
22SV10..4	3	4	55,6						52,8	50,7	49,1	47,6	36,9	35,1	31,5	26,6

Hydraulic performances in compliance with ISO 9906:2012 - Grade 3B (ex ISO 9906:1999 - Annex A)

10-22sv-4p60-en_b_th

33, 46, 66, 92, 125SV SERIES

HYDRAULIC PERFORMANCE TABLE AT 60 Hz, 4-POLE

PUMP TYPE	RATED POWER		Q = CAPACITY																
			l/min 0	150	200	225	300	350	400	450	500	600	700	800	900	1000	1100	1200	
			m ³ /h 0	9	12	13,5	18	21	24	27	30	36	42	48	54	60	66	72	
kW		HP		H = TOTAL HEAD IN METRES OF COLUMN OF WATER															
33SV2..4	1,1	1,5	17	16	15,5	15,2	13,8	12,5	10,7										
33SV3..4	1,5	2	25,7	24,5	23,8	23,3	21,4	19,4	16,9										
33SV4..4	2,2	3	34	32,2	31,2	30,6	27,9	25,3	21,8										
33SV5..4	3	4	42,7	40,6	39,4	38,6	35,3	32	27,7										
33SV6..4	3	4	51,5	49,1	47,7	46,8	42,9	39	33,9										
33SV7..4	4	5,5	59,9	57	55	54	49,5	45	38,9										
33SV8..4	5,5	7,5	69	66	64	63	58	53	46,2										
33SV9..4	5,5	7,5	77,5	74,1	72	71	65	59	51,5										
33SV10..4	5,5	7,5	85,9	82,1	80	78	72	65	56,7										
33SV11..4	7,5	10	94,9	90,8	88	87	80	73	63,5										
33SV12..4	7,5	10	103,3	98,8	96	94	87	79	68,7										
33SV13..4	7,5	10	111,8	106,8	104	102	93	85	74										
46SV2..4	1,5	2	19			17,3	16,5	16	15	13,9	12,6	8,9							
46SV3..4	2,2	3	28,8			26,5	25,4	24,4	23,1	21,5	19,5	14,4							
46SV4..4	3	4	37,9			34,6	33,1	31,6	29,8	27,6	24,8	17,7							
46SV5..4	4	5,5	47,6			43,6	41,7	40	37,7	35	31,6	22,7							
46SV6..4	5,5	7,5	57,7			53,1	51	48,9	46,3	43,1	39,1	28,6							
46SV7..4	5,5	7,5	67,1			61,7	59	57	54	49,8	45	32,7							
46SV8..4	7,5	10	77			70,9	68	65	62	58	52	38,2							
46SV9..4	7,5	10	86,4			79,4	76,1	73	69	64	58	42,4							
46SV10..4	7,5	10	95,7			87,9	84	81	76	71	64	46,5							
46SV11..4	11	15	105,7			97,1	93	89	85	79	71	52							
46SV12..4	11	15	115,3			105,9	102	97	92	86	78	57							
46SV13..4	11	15	124,9			114,8	110	106	100	93	84	61							
66SV1..4	1,5	2	10,8				9,7	9,5	9,2	8,9	8,6	7,9	7,2	6,1	4,7				
66SV2..4	3	4	21,1				19,4	19	18,5	17,9	17,4	16,0	14,5	12,5	10,1				
66SV3..4	4	5,5	31,4				29,2	28,5	27,8	27	26,2	24,2	21,7	18,9	15,4				
66SV4..4	5,5	7,5	42				39,4	38,7	37,8	36,9	35,8	33,2	30	26,1	21,3				
66SV5..4	7,5	10	52,5				49,4	48,5	47,5	46,3	44,9	41,7	37,8	32,8	26,5				
66SV6..4	7,5	10	62,7				59	58	57	55	53	49,6	44,8	38,7	31,1				
66SV7..4	11	15	73,2				68,8	67	66	64	62	58	52	45,2	36,3				
66SV8..4	11	15	83,7				78,6	77	75	73	71	66	60	52	41,5				
92SV1..4	1,5	2	11,8							9,8	9,5	8,9	8,3	7,7	7,1	6,4	5,5	4,1	
92SV2..4	3	4	23,4							20	19,4	18,3	17,1	16	14,8	13,4	11,7	9,4	
92SV3..4	5,5	7,5	35,4							31	30,2	28,5	26,8	25,2	23,4	21,5	19	15,9	
92SV4..4	7,5	10	47,2							41,4	40,3	38	35,8	33,6	31,2	28,6	25,4	21,3	
92SV5..4	7,5	10	58,5							51,2	50	46,9	44,1	41,4	38,4	35,1	31,1	25,8	
92SV6..4	11	15	70,2							61,4	60	56	53	50	46,1	42,1	37,3	30,9	
92SV7..4	11	15	81,9							71,6	70	66	62	58	54	49	43,5	36,1	
92SV8..4	15	20	93,6							81,8	80	75	71	66	62	56	50	41,2	

Hydraulic performances in compliance with ISO 9906:2012 - Grade 3B (ex ISO 9906:1999 - Annex A)

33-92sv-4p60-en_b_th

PUMP TYPE	RATED POWER		Q = DELIVERY															
			l/min 0	250	300	375	450	500	650	750	850	1000	1200	1300	1400	1500		
			m ³ /h 0	15,0	18,0	22,5	27,0	30,0	39,0	45,0	51,0	60,0	72,0	78,0	84,0	90,0		
kW		HP		H = TOTAL HEAD IN METRES OF COLUMN OF WATER														
125SV1..4	2,2	3	10,0						7,9	7,4	7,1	6,8	6,2	5,3	4,7	4,0	3,2	
125SV2/2A..4	3	4	18,3						15,4	14,6	14,1	13,5	12,4	10,6	9,6	8,4	7,0	
125SV3/3B..4	4	5,5	25,5						21,3	20,1	19,3	18,3	16,7	13,9	12,2	10,3	8,0	
125SV4/4A..4	5,5	7,5	36,5						30,9	29,3	28,1	26,9	24,8	21,3	19,2	16,8	14,1	
125SV5/5A..4	7,5	10	45,6						38,6	36,6	35,2	33,6	31,0	26,6	24,0	21,0	17,6	
125SV6..4	11	15	58,7						50,1	47,7	46,0	44,2	41,1	36,1	33,2	29,8	26,1	
125SV7..4	11	15	68,5						58,4	55,6	53,7	51,5	48,0	42,2	38,7	34,8	30,4	
125SV8..4	15	20,5	78,3						66,8	63,6	61,3	58,9	54,8	48,2	44,2	39,8	34,8	

Hydraulic performances in compliance with ISO 9906:2012 - Grade 3B (ex ISO 9906:1999 - Annex A)

125sv-4p60-en_c_th

1SV SERIES

DIMENSIONS AND WEIGHTS AT 60 Hz, 4-POLE

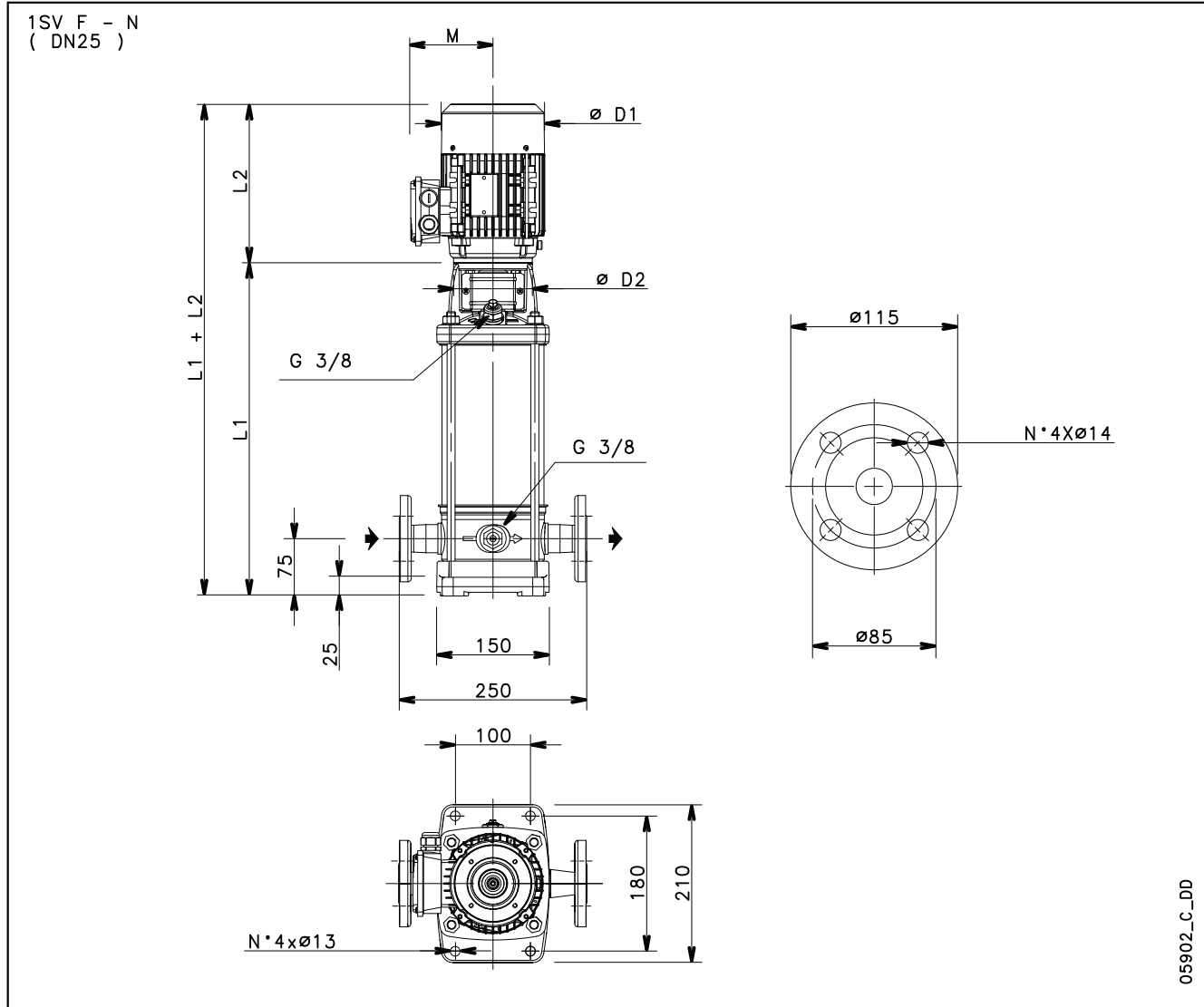

05902_C_DD

PUMP TYPE	MOTOR		DIMENSIONS (mm)					WEIGHT kg	
	kW	SIZE	L1	L2	D1	D2	M	PUMP	ELECTRIC PUMP
1SV03..4..	0,25	71	278	213	138	105	110	8,6	14,3
1SV05..4..	0,25	71	318	213	138	105	110	9,4	15,1
1SV07..4..	0,25	71	358	213	138	105	110	10,2	15,9
1SV09..4..	0,25	71	398	213	138	105	110	11	16,7
1SV11..4..	0,25	71	438	213	138	105	110	11,8	17,5
1SV13..4..	0,25	71	478	213	138	105	110	12,6	18,3
1SV15..4..	0,25	71	518	213	138	105	110	13,4	19,1
1SV17..4..	0,25	71	558	213	138	105	110	14,2	19,9
1SV18..4..	0,25	71	578	213	138	105	110	14,6	20,3
1SV20..4..	0,25	71	618	213	138	105	110	15,4	21,1
1SV22..4..	0,25	71	658	213	138	105	110	16,2	21,9
1SV24..4..	0,25	71	698	213	138	105	110	17	22,7
1SV26..4..	0,37	71	738	213	138	105	110	17,8	23,8
1SV28..4..	0,37	71	778	213	138	105	110	18,6	24,6

1sv-4p60-en_c_td

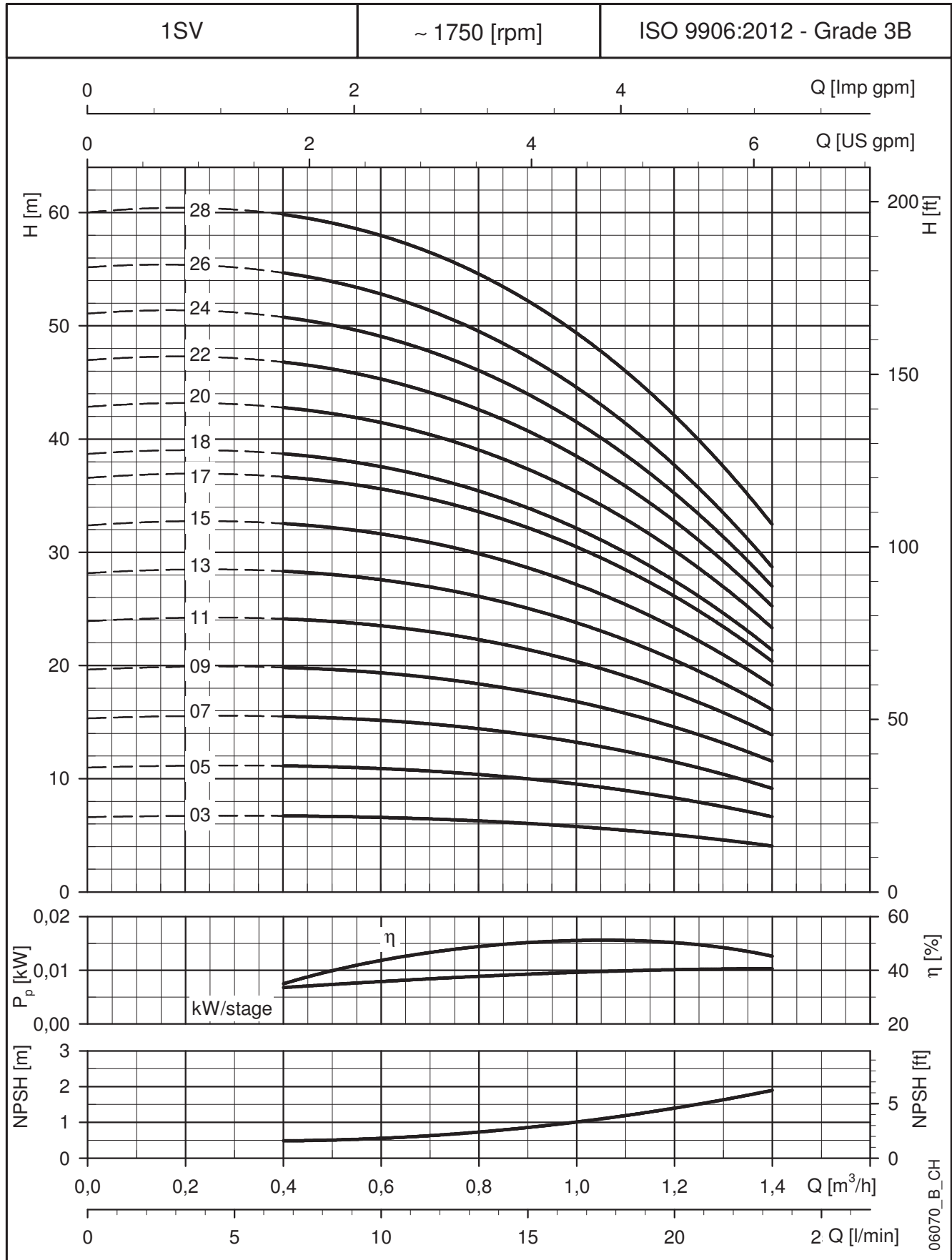
**1SV SERIES
OPERATING CHARACTERISTICS AT 60 Hz, 4-POLE**

These performances are valid for liquids with density $\rho = 1.0 \text{ Kg/dm}^3$ and kinematic viscosity $\nu = 1 \text{ mm}^2/\text{sec}$.

3SV SERIES DIMENSIONS AND WEIGHTS AT 60 Hz, 4-POLE

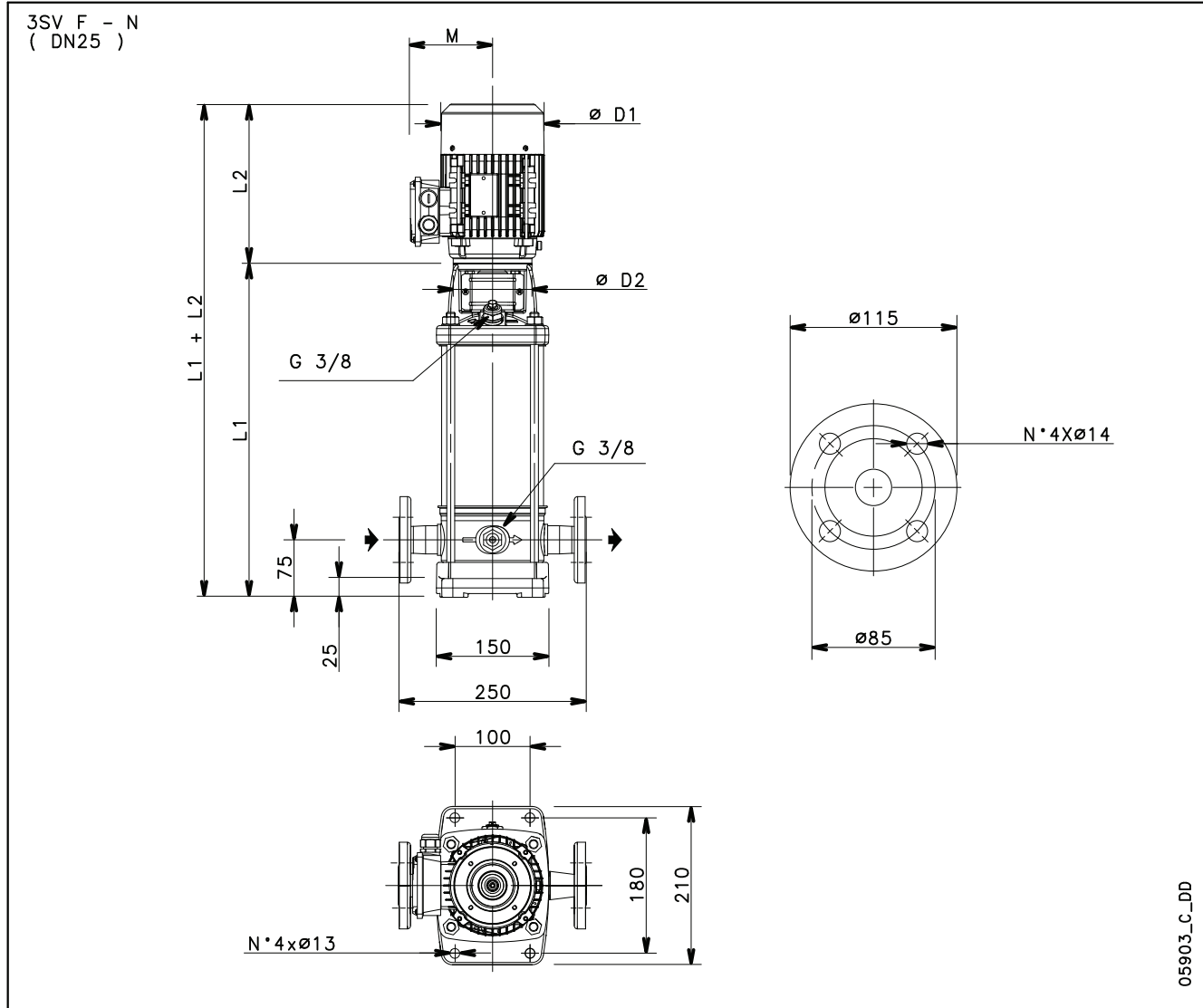

05903_C_DD

PUMP TYPE	MOTOR		DIMENSIONS (mm)					WEIGHT kg	
	kw	SIZE	L1	L2	D1	D2	M	PUMP	ELECTRIC PUMP
3SV02..4..	0,25	71	278	213	138	105	110	8	13,7
3SV04..4..	0,25	71	298	213	138	105	110	8,8	14,5
3SV06..4..	0,25	71	338	213	138	105	110	9,7	15,4
3SV08..4..	0,25	71	378	213	138	105	110	10,5	16,2
3SV10..4..	0,25	71	418	213	138	105	110	11,3	17
3SV12..4..	0,25	71	458	213	138	105	110	12,1	17,8
3SV14..4..	0,37	71	498	213	138	105	110	12,9	18,9
3SV15..4..	0,37	71	518	213	138	105	110	13,3	19,3
3SV17..4..	0,37	71	558	213	138	105	110	14,1	20,1
3SV19..4..	0,37	71	598	213	138	105	110	14,9	20,9
3SV21..4..	0,55	80	648	231	159	120	128	15,7	23,9
3SV23..4..	0,55	80	688	231	159	120	128	16,5	24,7

3sv-4p60-en_c_td

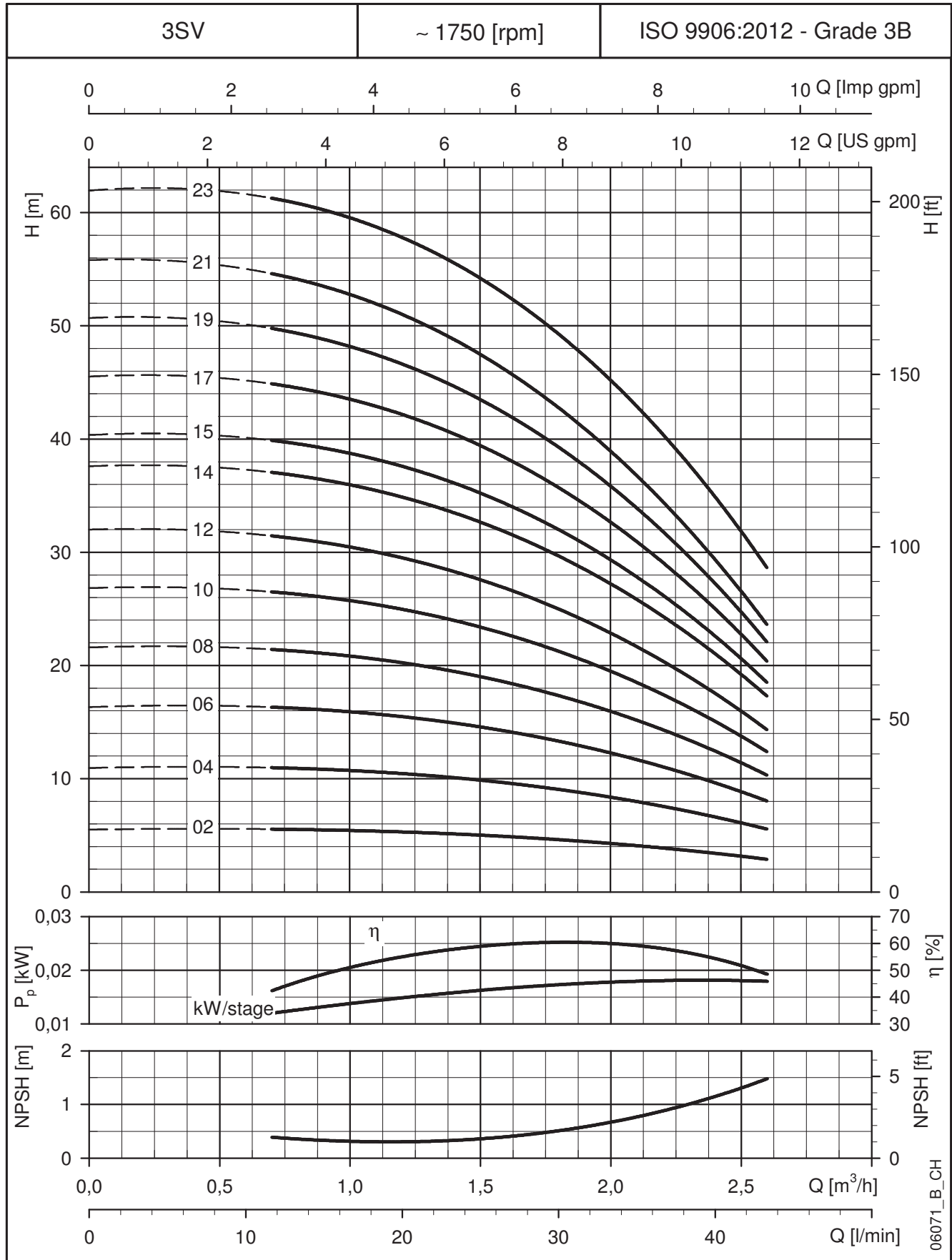
**3SV SERIES
OPERATING CHARACTERISTICS AT 60 Hz, 4-POLE**

These performances are valid for liquids with density $\rho = 1.0 \text{ Kg/dm}^3$ and kinematic viscosity $\nu = 1 \text{ mm}^2/\text{sec}$.

5SV SERIES

DIMENSIONS AND WEIGHTS AT 60 Hz, 4-POLE

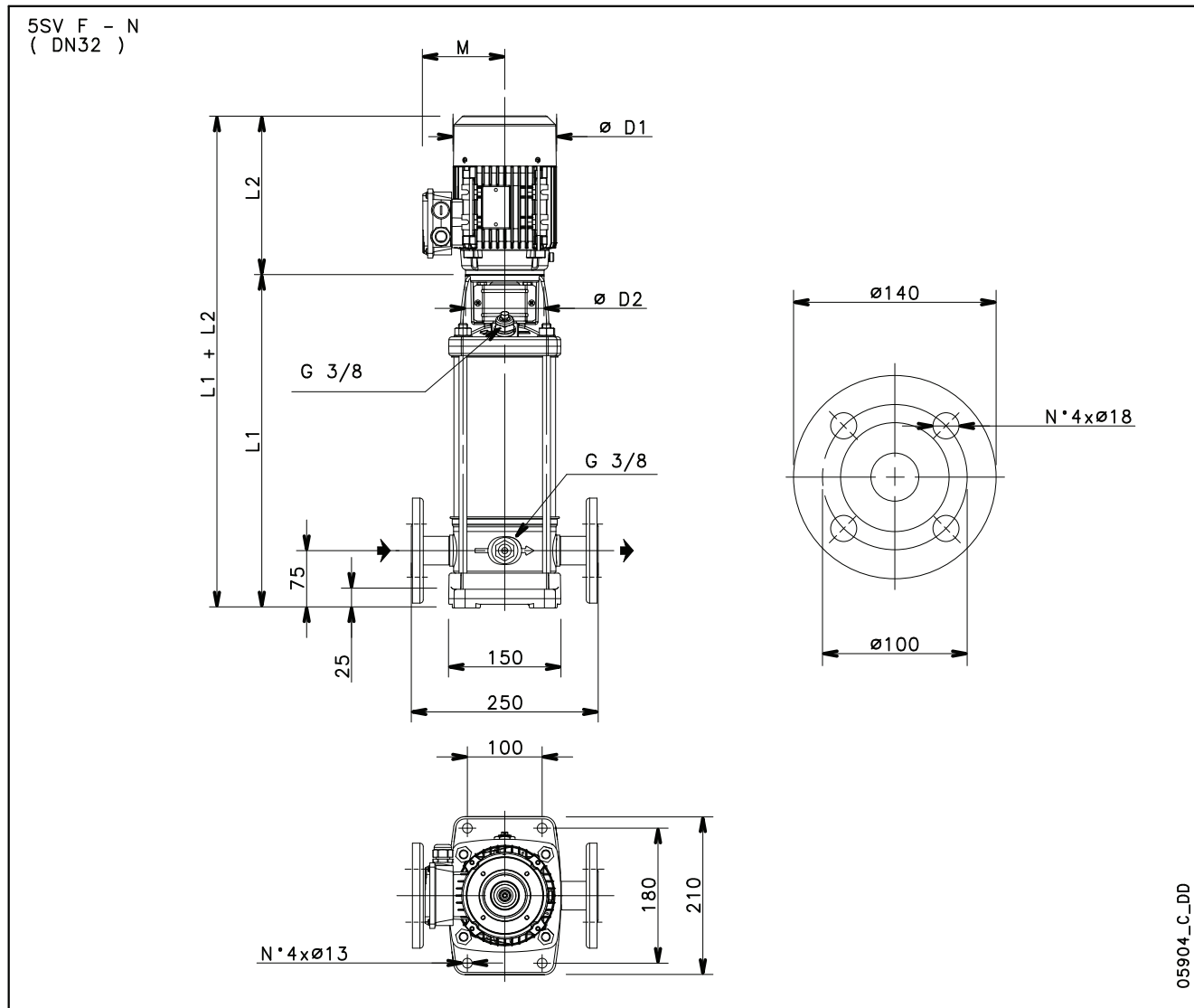

05904_C_DD

POMPA TIPO	MOTORE		DIMENSIONI (mm)					PESO kg	
	kW	SIZE	L1	L2	D1	D2	M	POMPA	ELETTRO- POMPA
5SV03..4..	0,25	71	293	213	138	105	110	8,9	14,6
5SV05..4..	0,25	71	343	213	138	105	110	9,9	15,6
5SV07..4..	0,25	71	393	213	138	105	110	10,8	16,5
5SV09..4..	0,37	71	443	213	138	105	110	11,8	17,8
5SV11..4..	0,37	71	493	213	138	105	110	12,8	18,8
5SV13..4..	0,55	80	553	231	159	120	128	14,1	22,3
5SV15..4..	0,55	80	603	231	159	120	128	15	23,2
5SV17..4..	0,55	80	653	231	159	120	128	15	23,2
5SV19..4..	0,75	80	703	231	159	120	128	16,9	29
5SV21..4..	0,75	80	753	231	159	120	128	17,9	30
5SV23..4..	0,75	80	803	231	159	120	128	18,8	31

5sv-4p60_d_td

5SV SERIES
OPERATING CHARACTERISTICS AT 60 Hz, 4-POLE

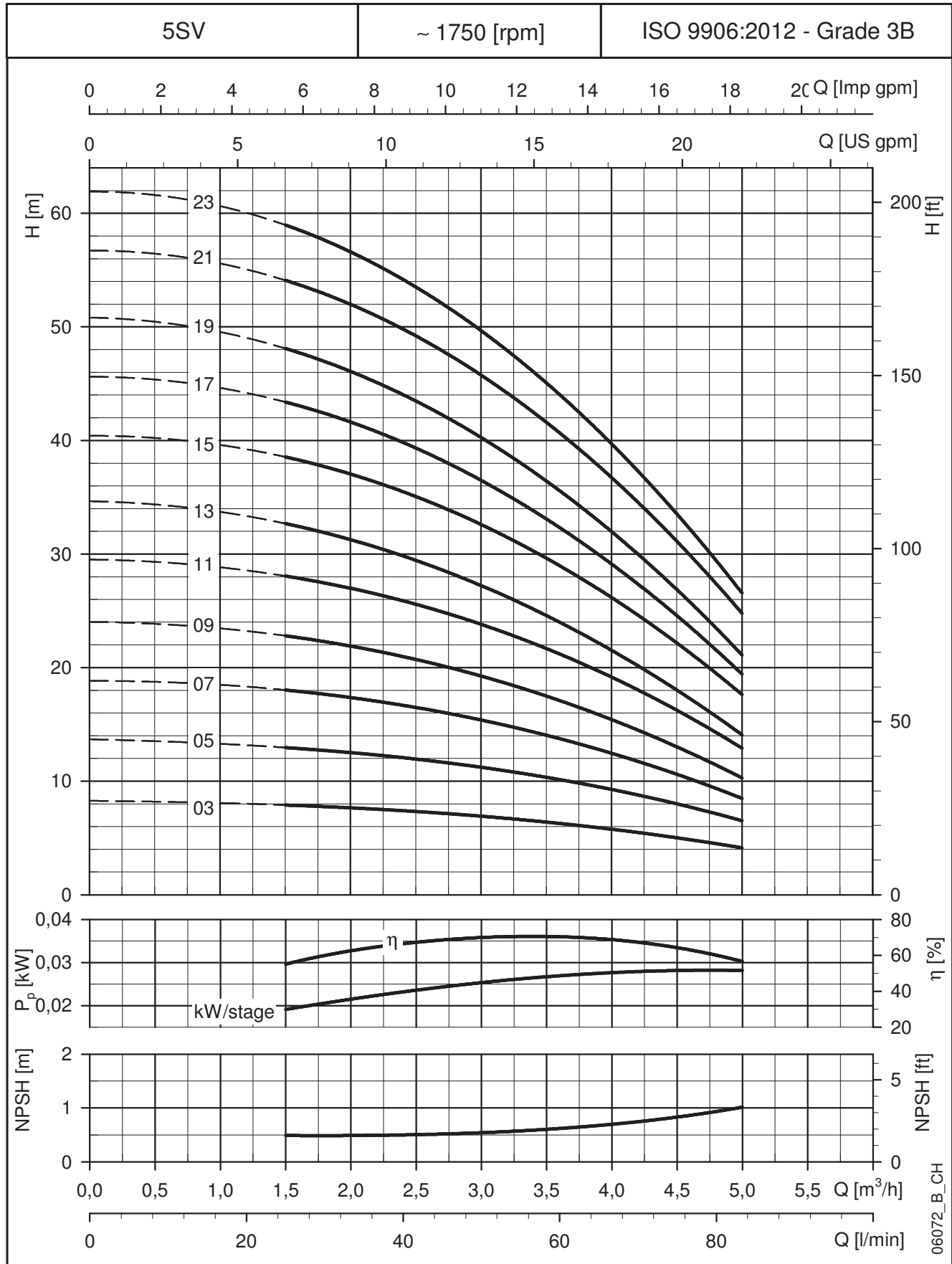

These performances are valid for liquids with density $\rho = 1.0 \text{ Kg/dm}^3$ and kinematic viscosity $\nu = 1 \text{ mm}^2/\text{sec}$.

10SV SERIES

DIMENSIONS AND WEIGHTS AT 60 Hz, 4-POLE

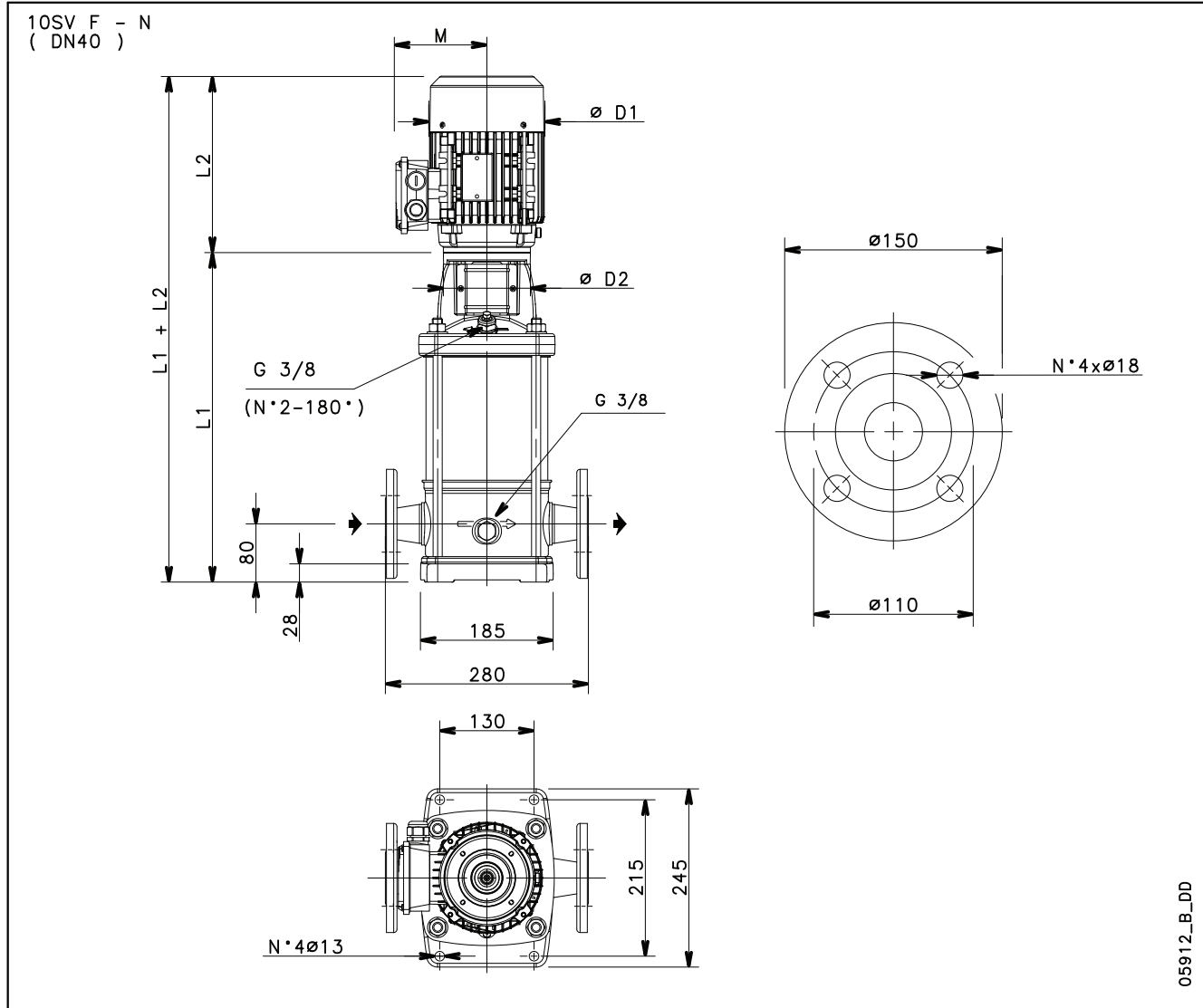

05912_B_DD

PUMP TYPE	MOTOR		DIMENSIONS (mm)					WEIGHT kg	
	kw	SIZE	L1	L2	D1	D2	M	PUMP	ELECTRIC PUMP
10SV03..4..	0,55	80	389	231	159	120	128	16,1	24,3
10SV05..4..	0,55	80	453	231	159	120	128	18	26,2
10SV07..4..	0,75	80	517	231	159	120	128	19,9	32
10SV09..4..	0,75	80	581	231	159	120	128	21,7	33,8
10SV11..4..	1,1	90	655	298	174	140	134	24	41,4
10SV13..4..	1,1	90	719	298	174	140	134	25,8	43,2
10SV15..4..	1,5	90	783	298	174	140	134	27,7	47,7

10sv-4p60-en_d_td

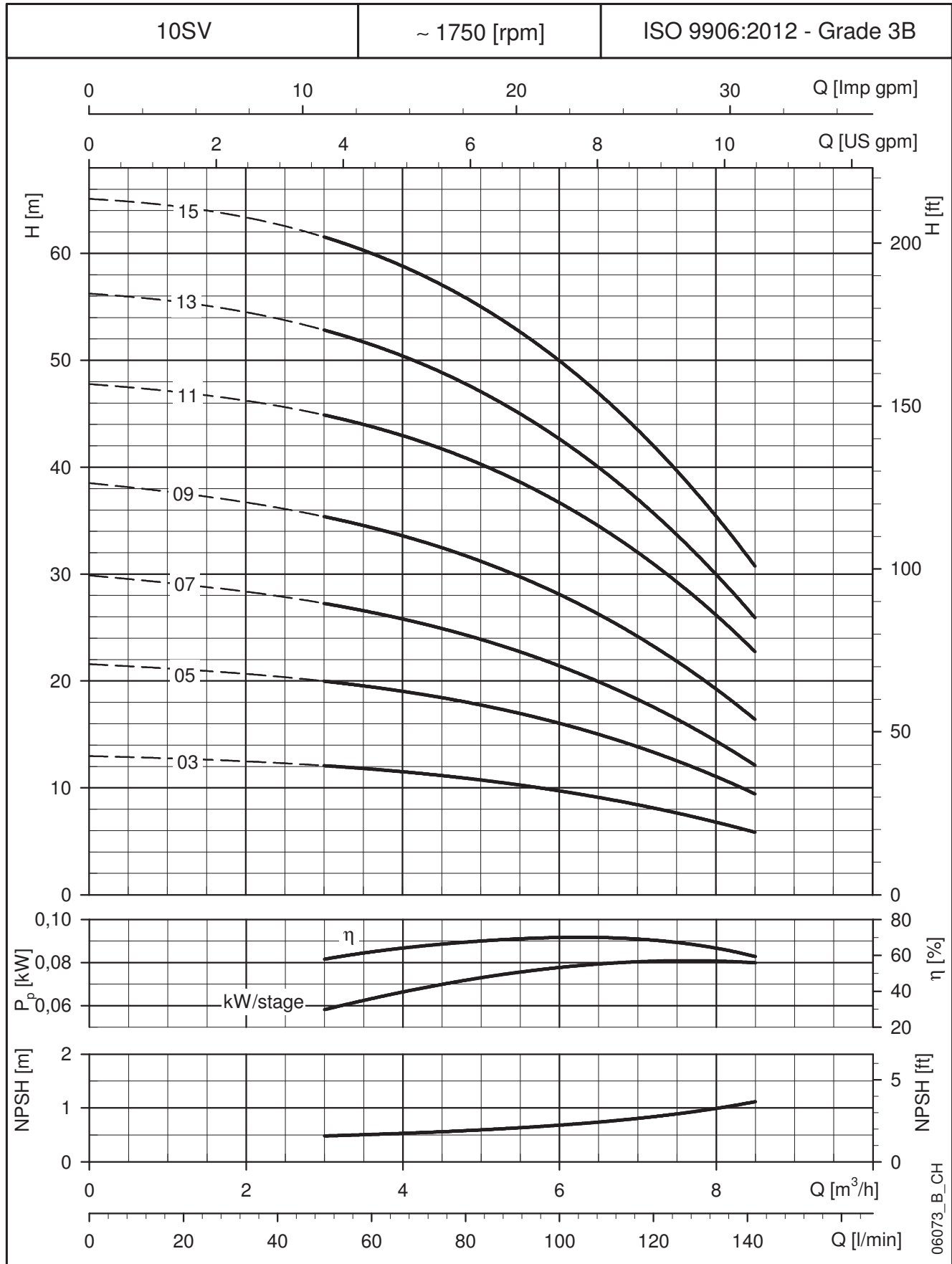
**10SV SERIES
OPERATING CHARACTERISTICS AT 60 Hz, 4-POLE**

These performances are valid for liquids with density $\rho = 1.0 \text{ Kg/dm}^3$ and kinematic viscosity $\nu = 1 \text{ mm}^2/\text{sec}$.

15SV SERIES

DIMENSIONS AND WEIGHTS AT 60 Hz, 4-POLE

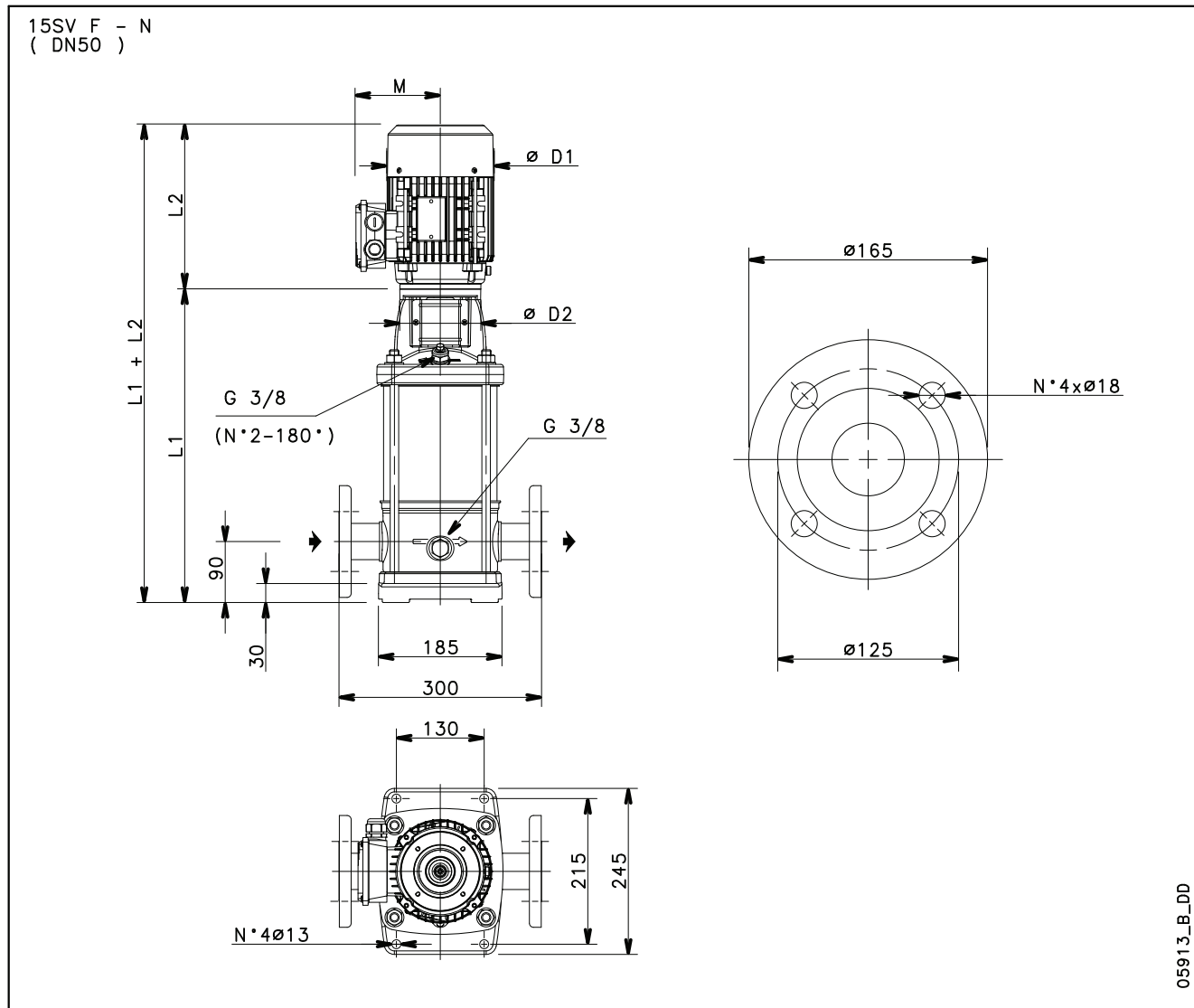

PUMP TYPE	MOTOR		DIMENSIONS (mm)					WEIGHT kg	
	kW	SIZE	L1	L2	D1	D2	M	PUMP	ELECTRIC PUMP
15SV03..4..	0,55	80	447	231	159	120	128	17,9	26,1
15SV04..4..	0,75	80	495	231	159	120	128	19,3	31,4
15SV05..4..	1,1	90	553	298	174	140	134	21,1	38,5
15SV06..4..	1,1	90	601	298	174	140	134	22,5	39,9
15SV07..4..	1,5	90	649	298	174	140	134	23,8	43,8
15SV08..4..	1,5	90	697	298	174	140	134	25,2	45,2
15SV09..4..	2,2	100	755	322	214	160	168	27,4	56,2
15SV10..4..	2,2	100	803	322	214	160	168	28,7	57,5
15SV11..4..	2,2	100	851	322	214	160	168	30	58,8
15SV12..4..	2,2	100	899	322	214	160	168	31,4	60,2

15sv-4p60-en_d_td

15SV SERIES
OPERATING CHARACTERISTICS AT 60 Hz, 4-POLE

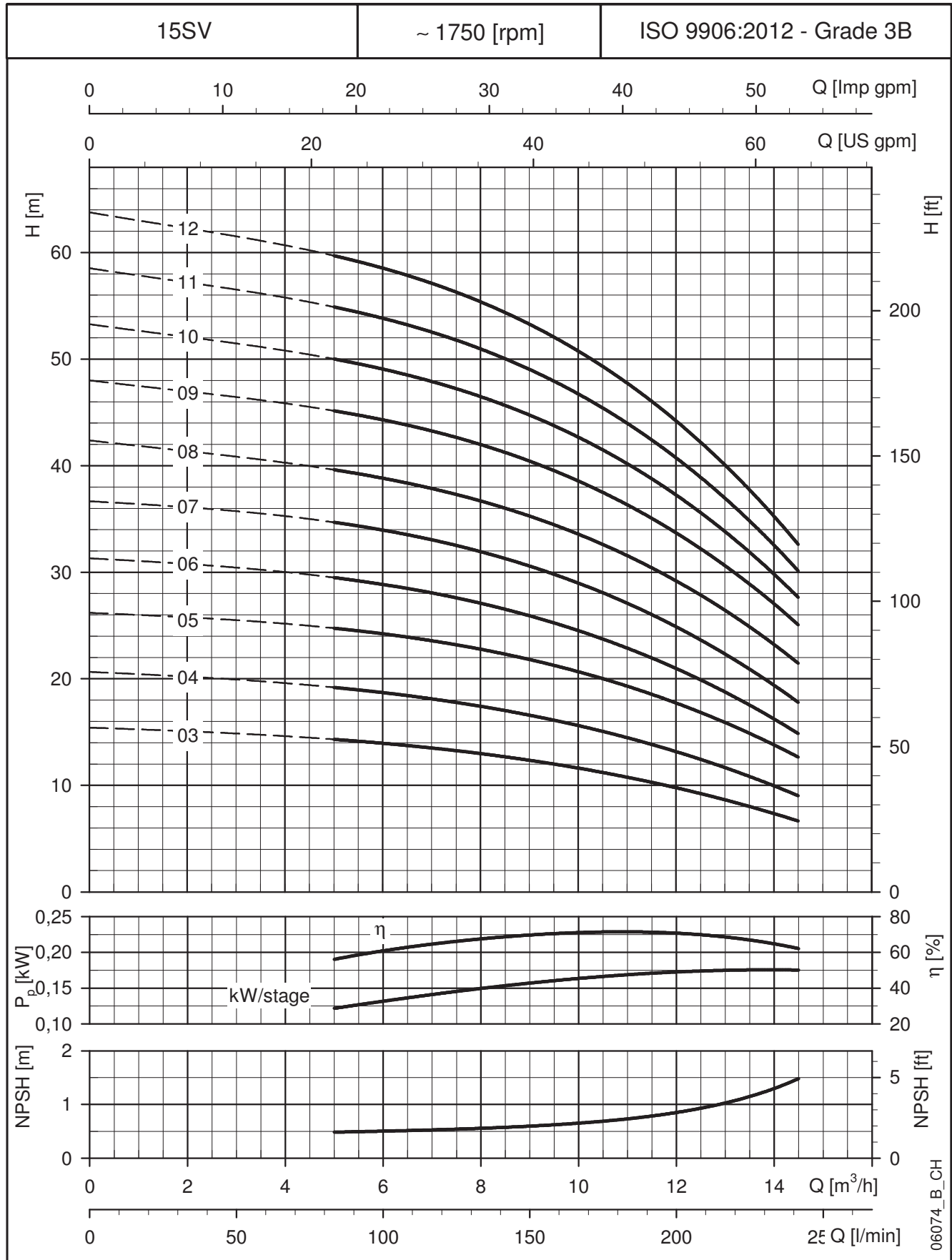

These performances are valid for liquids with density $\rho = 1.0 \text{ Kg/dm}^3$ and kinematic viscosity $\nu = 1 \text{ mm}^2/\text{sec}$.

22SV SERIES
DIMENSIONS AND WEIGHTS AT 60 Hz, 4-POLE

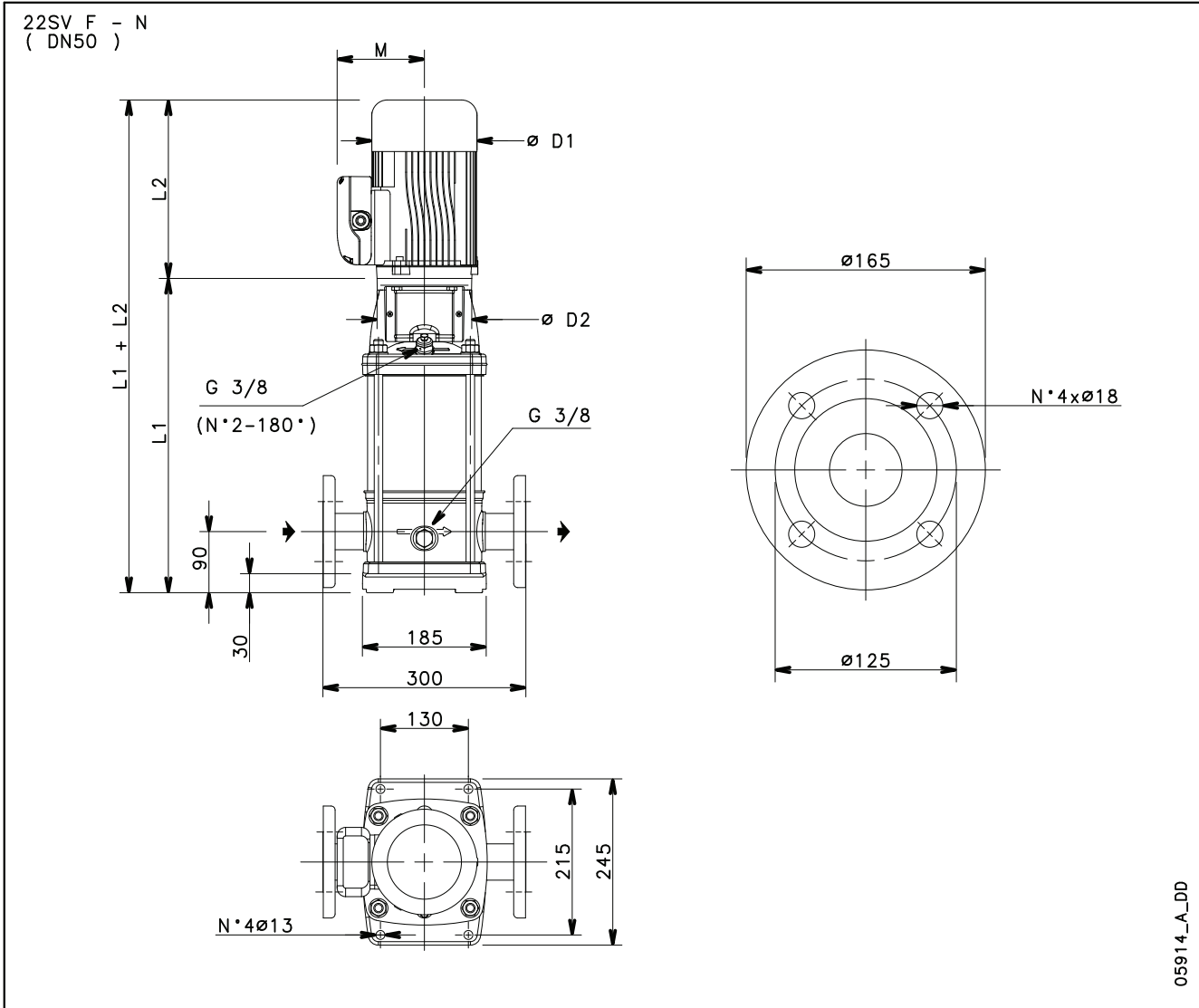

PUMP TYPE	MOTOR		DIMENSIONS (mm)					WEIGHT kg	
	kW	SIZE	L1	L2	D1	D2	M	PUMP	ELECTRIC PUMP
22SV02..4..	0,55	80	399	231	159	120	128	16,9	25,1
22SV03..4..	0,75	80	447	231	159	120	128	18,2	30,3
22SV04..4..	1,1	90	505	298	174	140	134	19,8	37,2
22SV05..4..	1,5	90	553	298	174	140	134	21	41
22SV06..4..	1,5	90	601	298	174	140	134	22,4	42,4
22SV07..4..	2,2	100	659	322	214	160	168	24,6	53,4
22SV08..4..	2,2	100	707	322	214	160	168	25,9	54,7
22SV09..4..	2,2	100	755	322	214	160	168	27,2	56
22SV10..4..	3	100	803	353	214	160	168	28,6	60,6

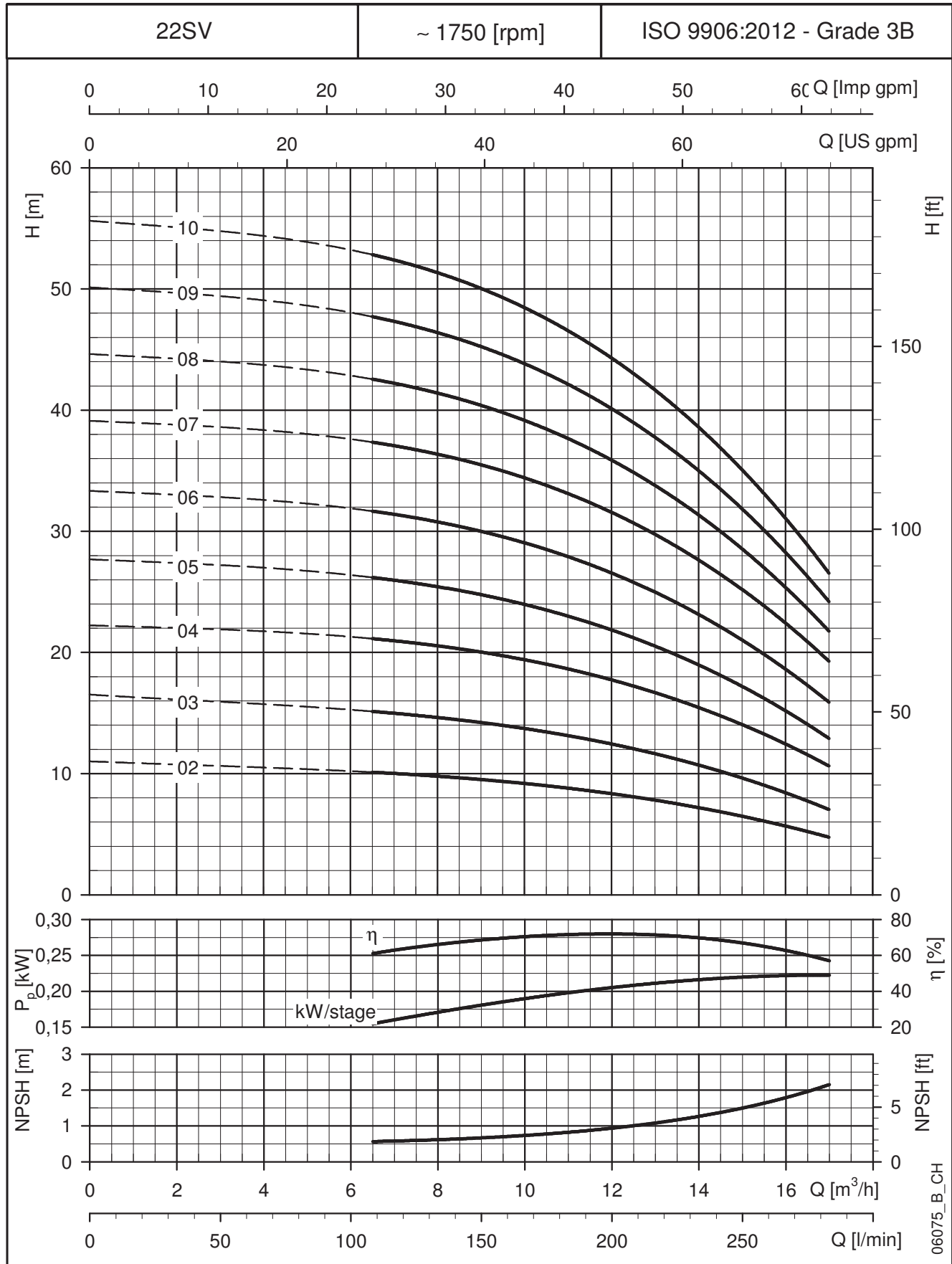
**22SV SERIES
OPERATING CHARACTERISTICS AT 60 Hz, 4-POLE**

These performances are valid for liquids with density $\rho = 1.0 \text{ Kg/dm}^3$ and kinematic viscosity $\nu = 1 \text{ mm}^2/\text{sec}$.

33SV SERIES
DIMENSIONS AND WEIGHTS AT 60 Hz, 4-POLE

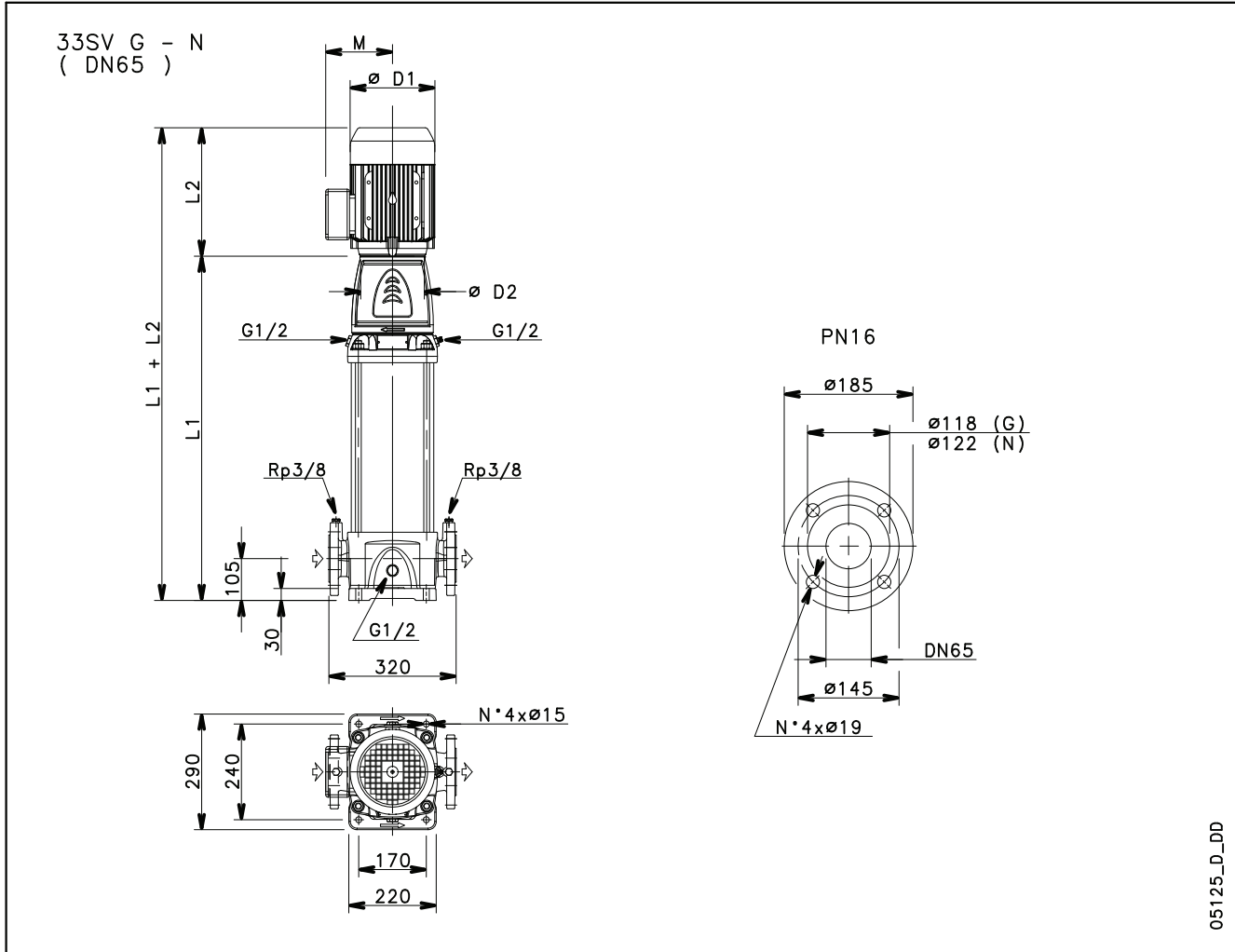

PUMP TYPE	MOTOR		DIMENSIONS (mm)						WEIGHT kg	
	kW	SIZE	L1	L2	D1	D2	M	PN	PUMP	ELECTRIC PUMP
33SV2..4..	1,1	90	564	298	174	164	134	16	56	74
33SV3..4..	1,5	90	639	298	174	164	134	16	60	83
33SV4..4..	2,2	100	714	322	214	164	168	16	64	93
33SV5..4..	3	100	789	353	214	164	168	16	68	100
33SV6..4..	3	100	864	353	214	164	168	16	72	104
33SV7..4..	4	112	939	398	214	164	168	16	75	129
33SV8..4..	5,5	132	1034	405	256	300	191	16	84	146
33SV9..4..	5,5	132	1109	405	256	300	191	16	88	150
33SV10..4..	5,5	132	1184	405	256	300	191	16	92	154
33SV11..4..	7,5	132	1259	405	256	300	191	16	101	168
33SV12..4..	7,5	132	1334	405	256	300	191	16	105	172
33SV13..4..	7,5	132	1409	405	256	300	191	16	109	176

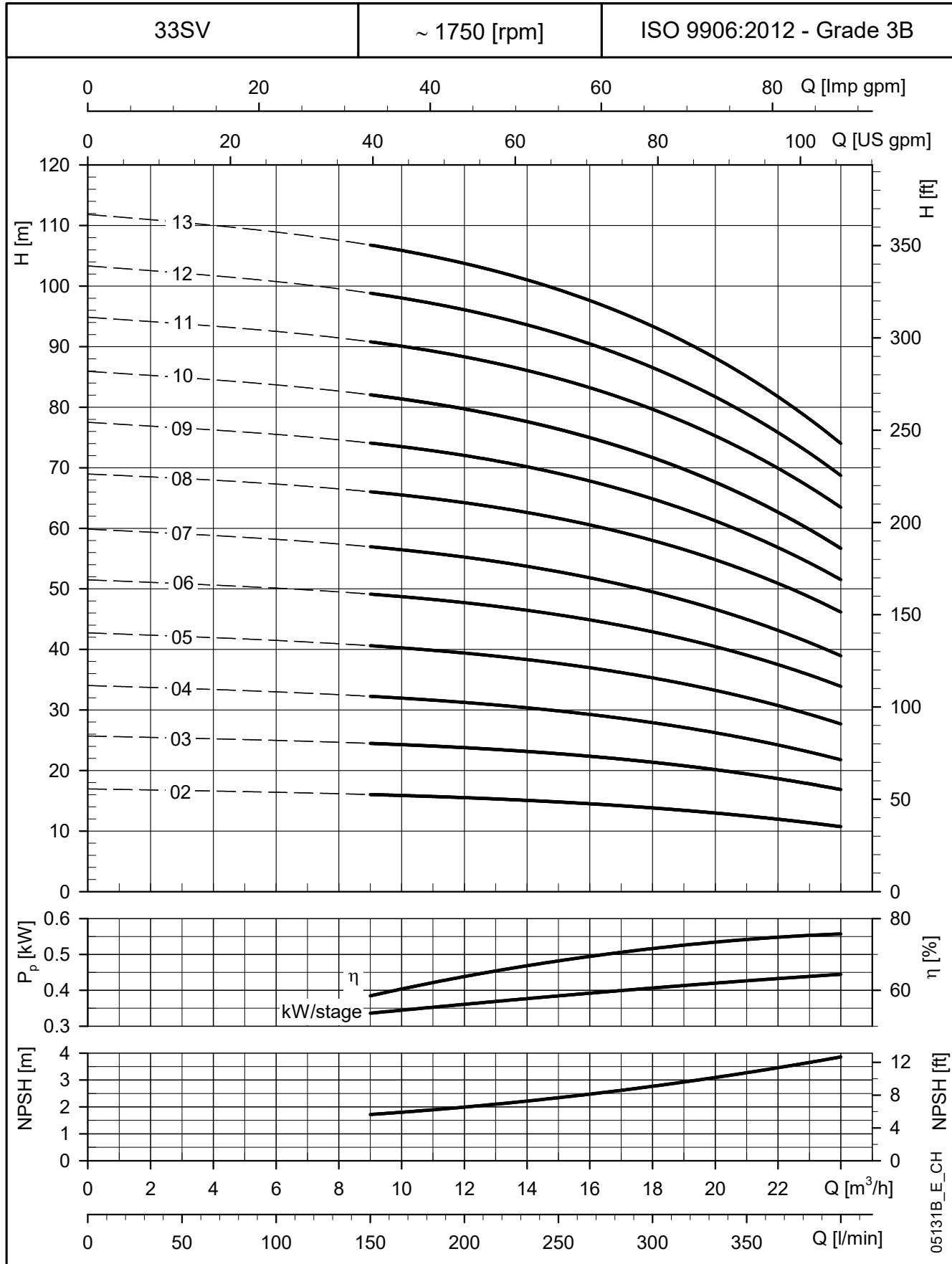
33SV SERIES
OPERATING CHARACTERISTICS AT 60 Hz, 4-POLE

These performances are valid for liquids with density $\rho = 1.0 \text{ Kg/dm}^3$ and kinematic viscosity $\nu = 1 \text{ mm}^2/\text{sec}$.

46SV SERIES
DIMENSIONS AND WEIGHTS AT 60 Hz, 4-POLE

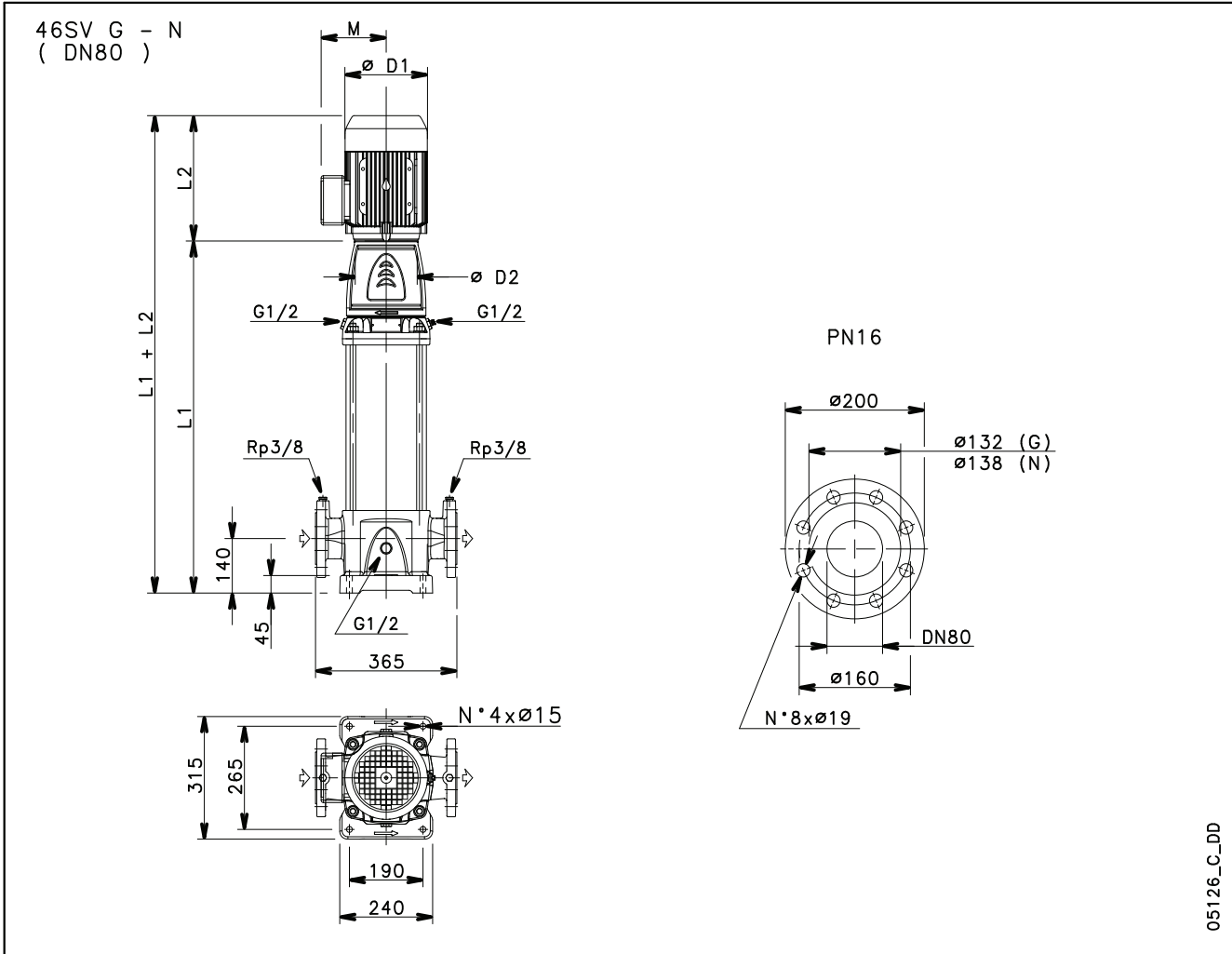

PUMP TYPE	MOTOR		DIMENSIONS (mm)						WEIGHT kg	
	kW	SIZE	L1	L2	D1	D2	M	PN	PUMP	ELECTRIC
46SV2..4..	1,5	90	604	298	174	164	134	16	61	84
46SV3..4..	2,2	100	679	322	214	164	168	16	65	94
46SV4..4..	3	100	754	353	214	164	168	16	69	101
46SV5..4..	4	112	829	398	214	164	168	16	73	127
46SV6..4..	5,5	132	924	405	256	300	191	16	82	144
46SV7..4..	5,5	132	999	405	256	300	191	16	85	147
46SV8..4..	7,5	132	1074	405	256	300	191	16	89	156
46SV9..4..	7,5	132	1149	405	256	300	191	16	93	160
46SV10..4..	7,5	132	1224	405	256	300	191	16	97	164
46SV11..4..	11	160	1334	494	313	350	240	16	109	235
46SV12..4..	11	160	1409	494	313	350	240	16	113	239
46SV13..4..	11	160	1484	494	313	350	240	16	117	243

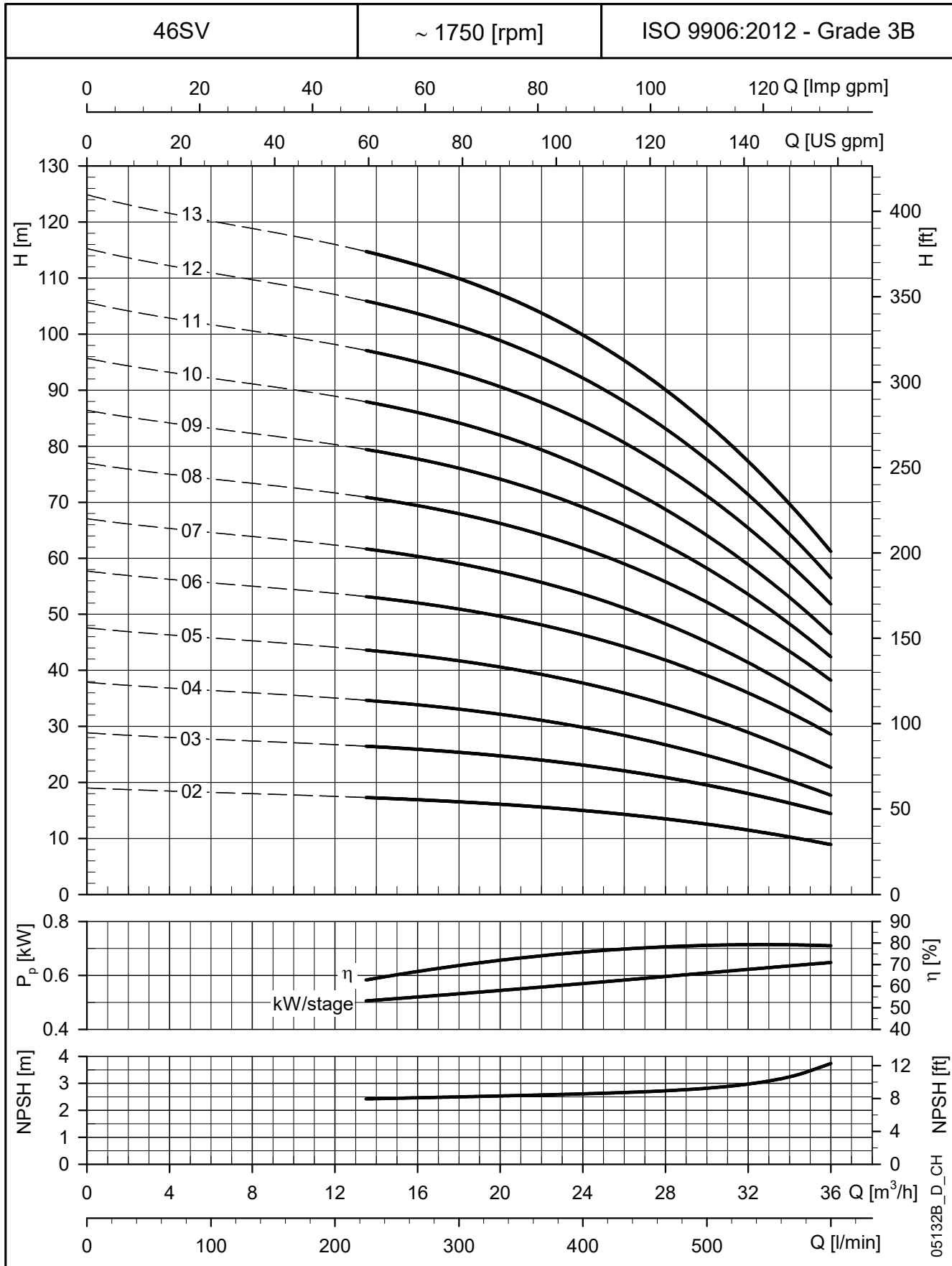
46SV SERIES
OPERATING CHARACTERISTICS AT 60 Hz, 4-POLE

 These performances are valid for liquids with density $\rho = 1.0 \text{ Kg/dm}^3$ and kinematic viscosity $\nu = 1 \text{ mm}^2/\text{sec}$.

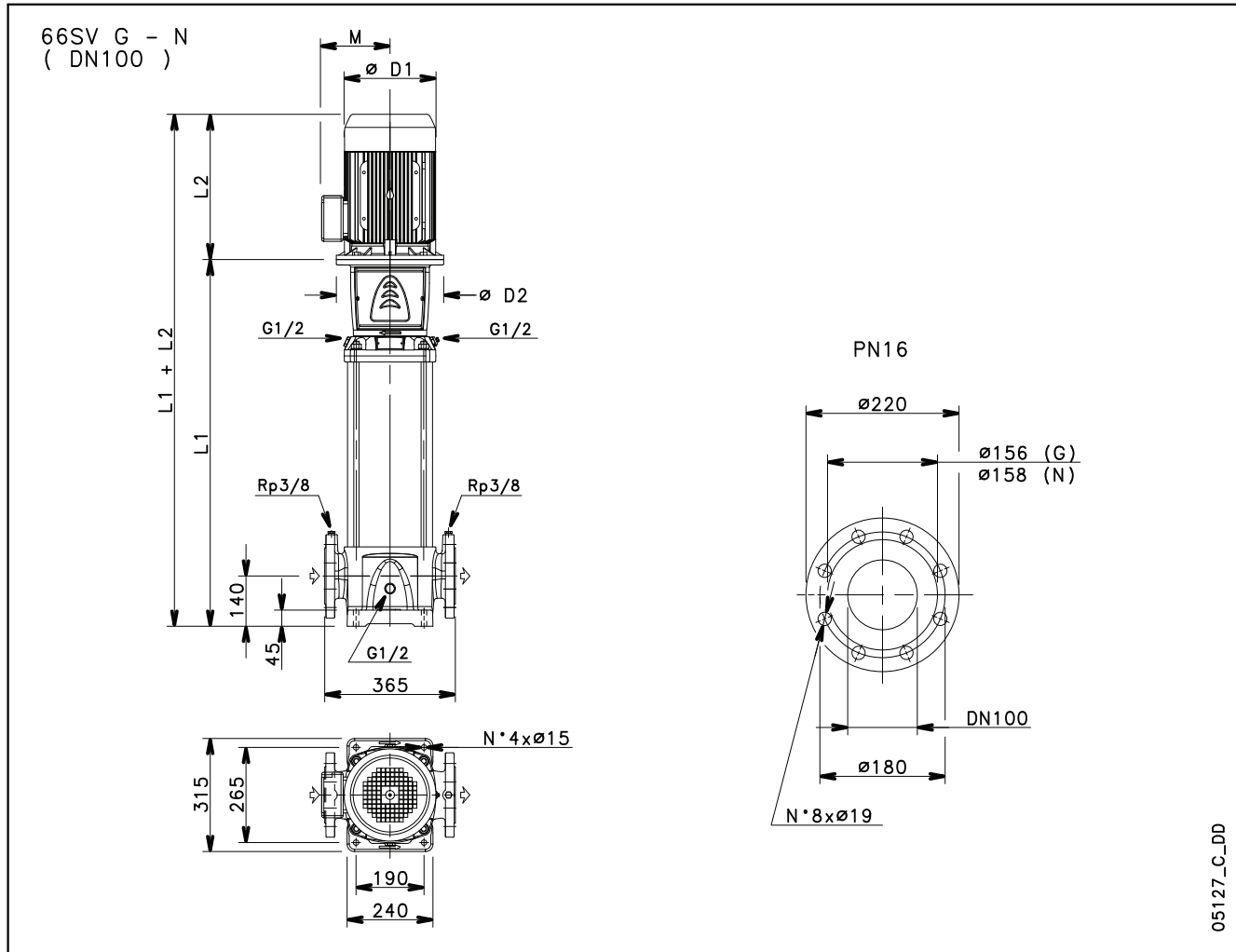
66SV SERIES DIMENSIONS AND WEIGHTS AT 60 Hz, 4-POLE

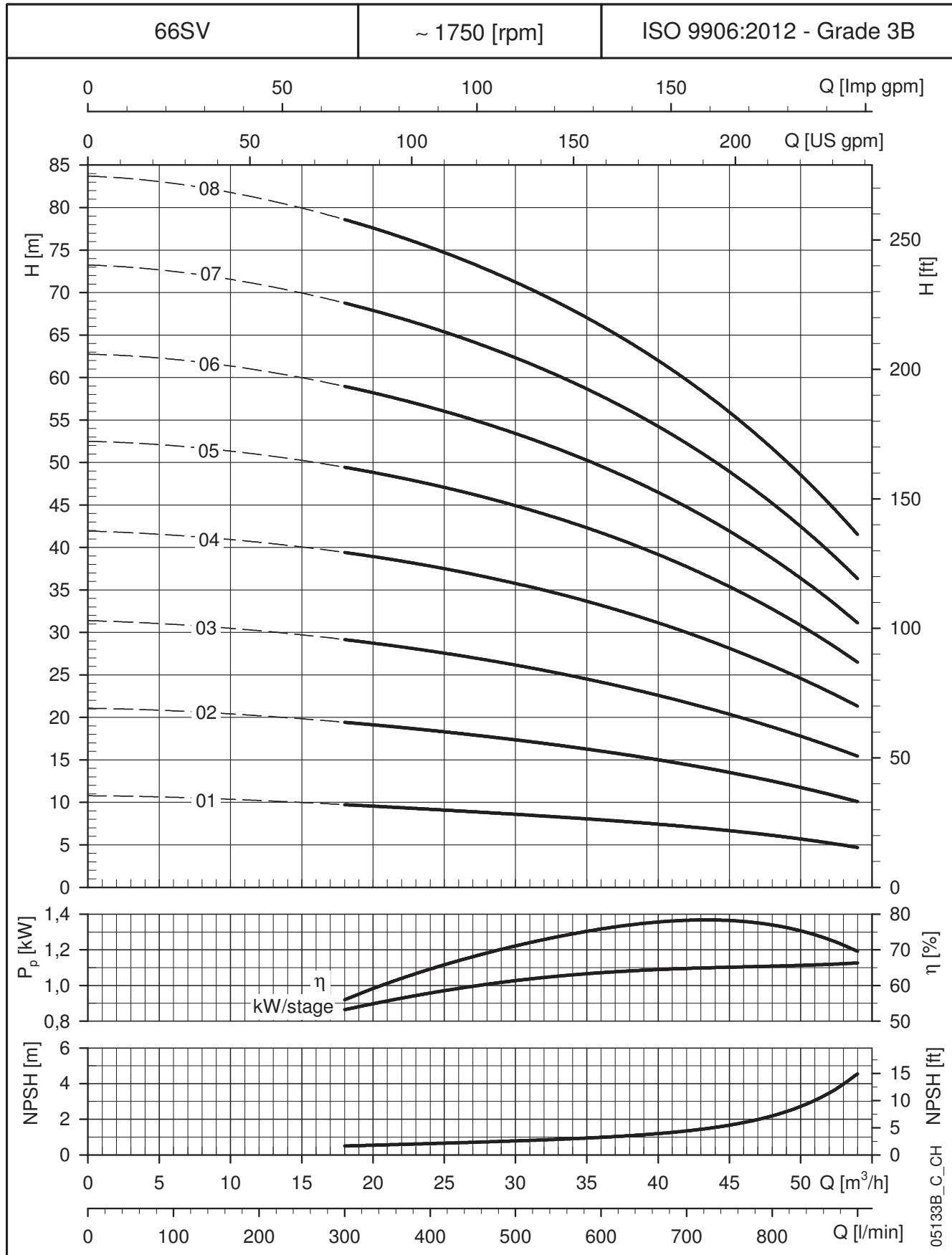

PUMP TYPE	MOTOR		DIMENSIONS (mm)						WEIGHT kg	
	kW	SIZE	L1	L2	D1	D2	M	PN	PUMP	ELECTRIC PUMP
66SV1..4..	1,5	90	554	298	174	164	134	16	66	89
66SV2..4..	3	100	644	353	214	164	168	16	72	104
66SV3..4..	4	112	734	398	214	164	168	16	77	131
66SV4..4..	5,5	132	844	405	256	300	191	16	87	149
66SV5..4..	7,5	132	934	405	256	300	191	16	92	159
66SV6..4..	7,5	132	1024	405	256	300	191	16	98	165
66SV7..4..	11	160	1149	494	313	350	240	16	107	233
66SV8..4..	11	160	1239	494	313	350	240	16	112	238

66SV SERIES
OPERATING CHARACTERISTICS AT 60 Hz, 4-POLE

These performances are valid for liquids with density $\rho = 1.0 \text{ Kg/dm}^3$ and kinematic viscosity $\nu = 1 \text{ mm}^2/\text{sec}$.

92SV SERIES DIMENSIONS AND WEIGHTS AT 60 Hz, 4-POLE

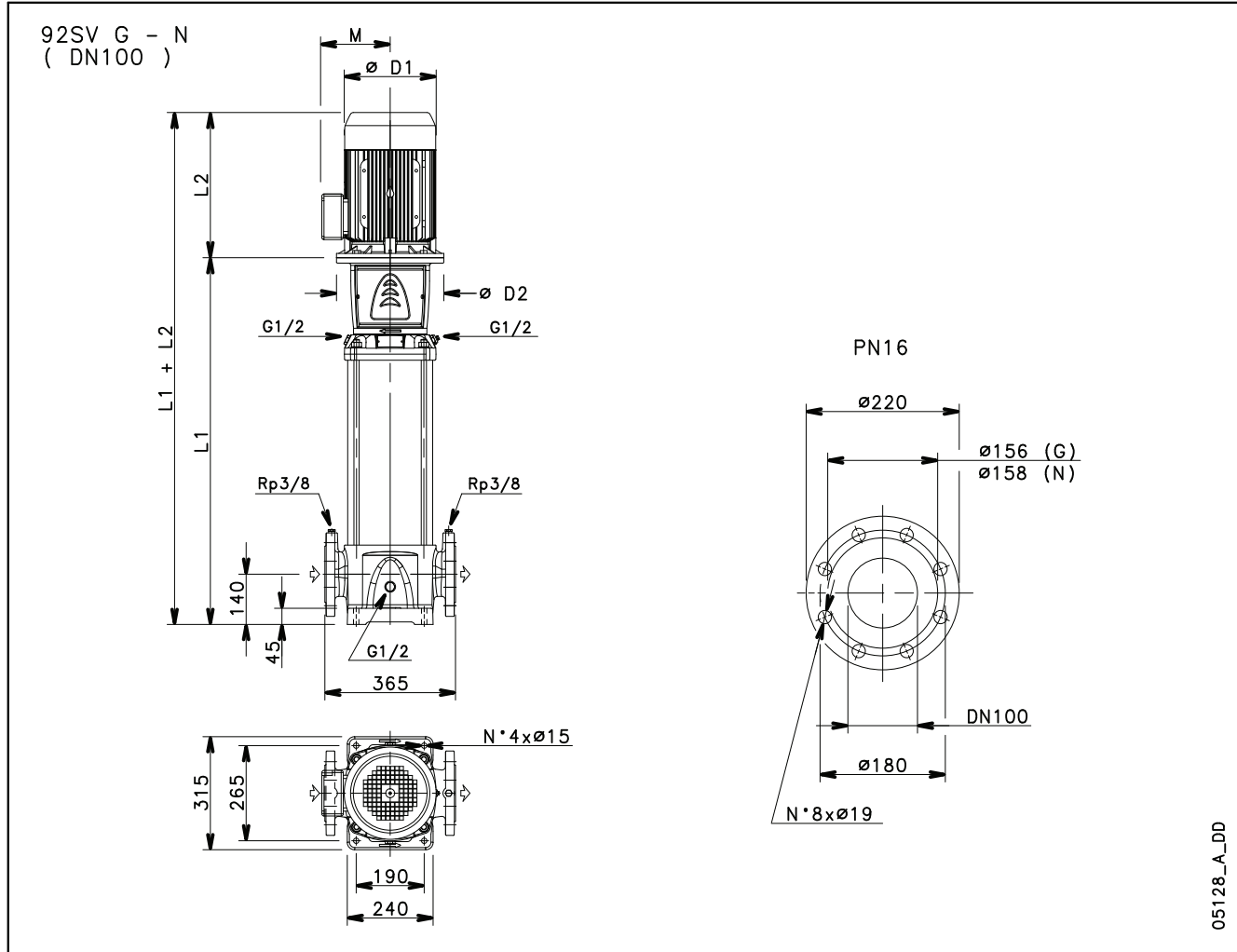

PUMP TYPE	MOTOR		DIMENSIONS (mm)						WEIGHT kg	
	kW	SIZE	L1	L2	D1	D2	M	PN	PUMP	ELECTRIC PUMP
92SV1..4..	1,5	90	554	298	174	164	134	16	66	89
92SV2..4..	3	100	644	353	214	164	168	16	71	103
92SV3..4..	5,5	132	754	405	256	300	191	16	82	144
92SV4..4..	7,5	132	844	405	256	300	191	16	87	154
92SV5..4..	7,5	132	934	405	256	300	191	16	92	159
92SV6..4..	11	160	1059	494	313	350	240	16	101	227
92SV7..4..	11	160	1149	494	313	350	240	16	106	232
92SV8..4..	15	160	1239	494	313	350	240	16	111	240

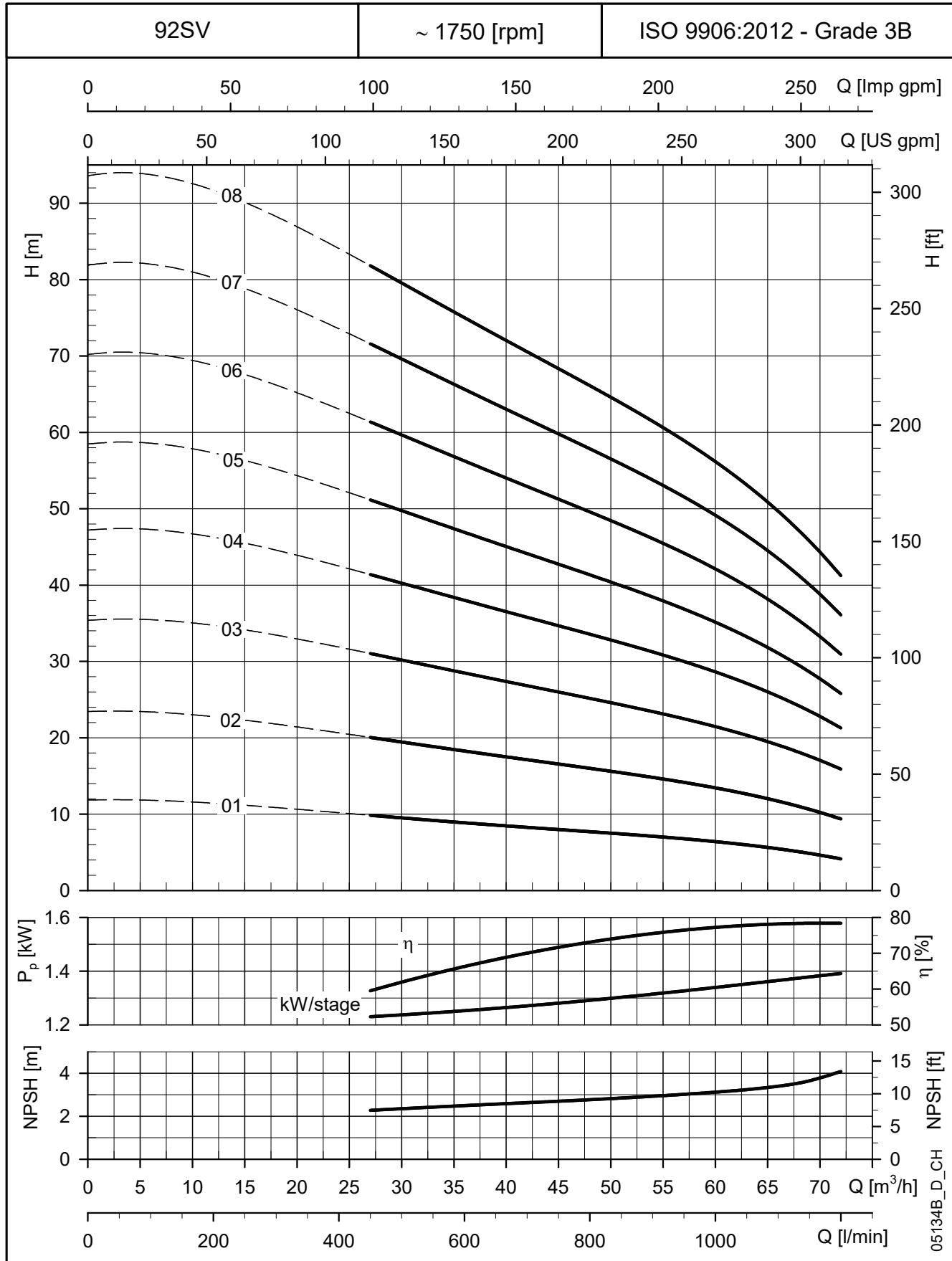
**92SV SERIES
OPERATING CHARACTERISTICS AT 60 Hz, 4-POLE**

These performances are valid for liquids with density $\rho = 1.0 \text{ Kg/dm}^3$ and kinematic viscosity $\nu = 1 \text{ mm}^2/\text{sec}$.

125SV SERIES
DIMENSIONS AND WEIGHTS AT 60 Hz, 4-POLE

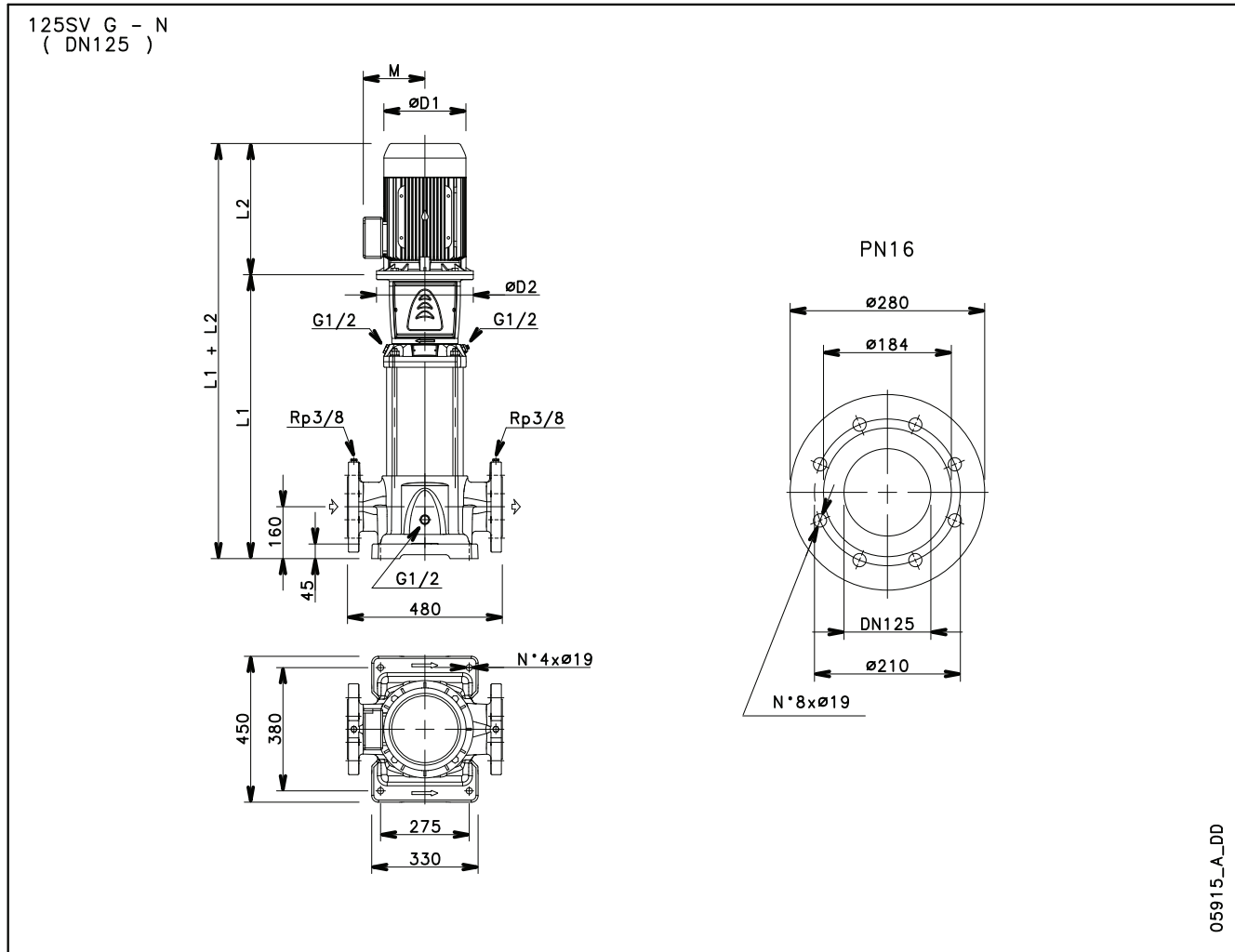

PUMP TYPE	MOTOR		DIMENSIONS (mm)						WEIGHT kg	
	kW	SIZE	L1	L2	D1	D2	M	PN	PUMP	ELECTRIC PUMP
125SV1..4..	2,2	100	673	322	214	160	168	16	110	139
125SV2/2A..4..	3	100	823	353	214	160	168	16	121	153
125SV3/3B..4..	4	112	973	398	214	160	168	16	133	184
125SV4/4A..4..	5,5	132	1143	405	256	300	191	16	149	212
125SV5/5A..4..	7,5	132	1293	405	256	300	191	16	160	227
125SV6..4..	11	160	1478	494	313	350	240	16	176	301
125SV7..4..	11	160	1628	494	313	350	240	16	190	315
125SV8..4..	15	160	1778	494	313	350	240	16	203	331

125sv-4p60-en_b_td

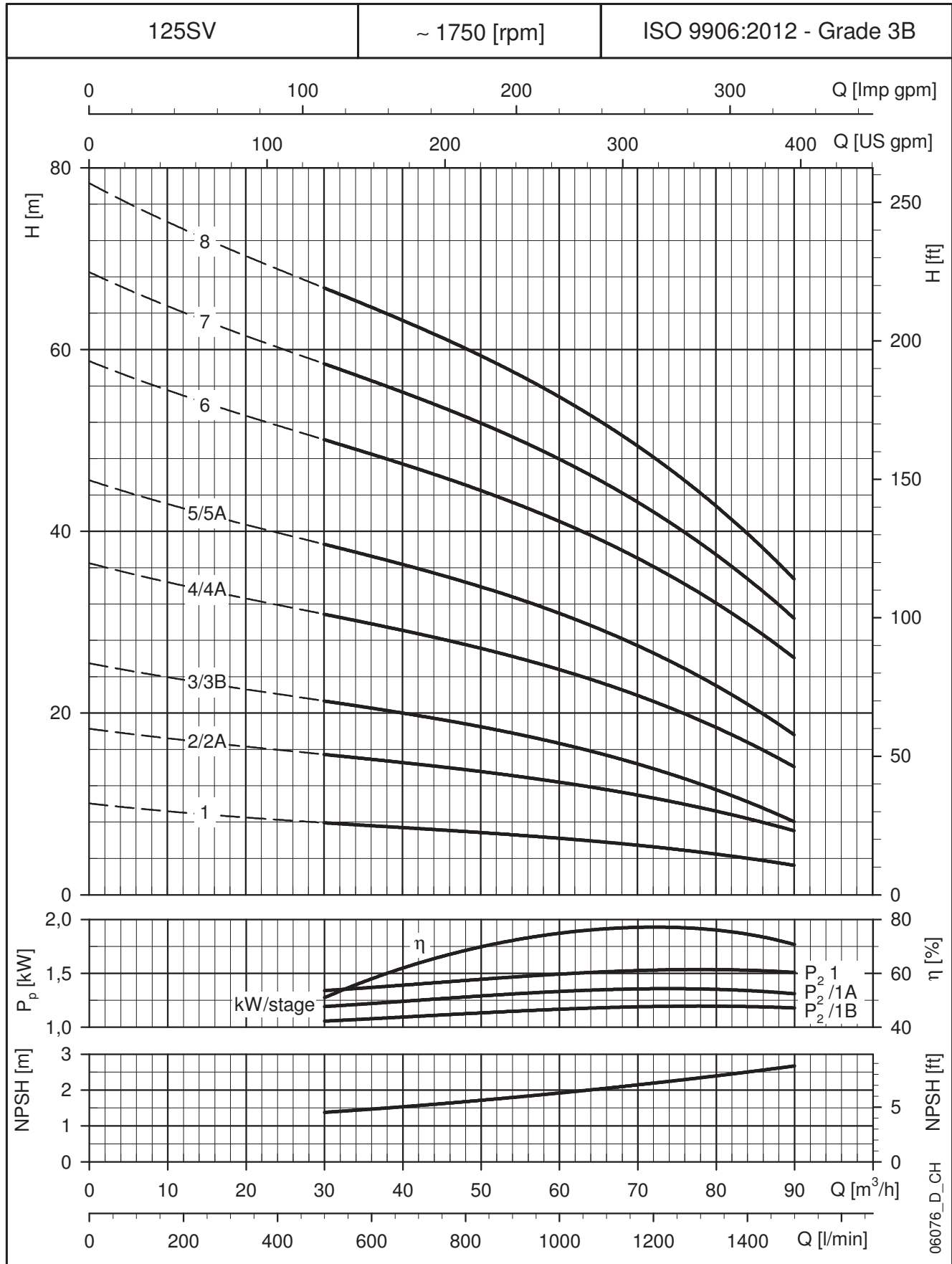
**125SV SERIES
OPERATING CHARACTERISTICS AT 60 Hz, 4-POLE**

These performances are valid for liquids with density $\rho = 1.0 \text{ Kg/dm}^3$ and kinematic viscosity $\nu = 1 \text{ mm}^2/\text{sec}$.

REDUCED OVERALL DIMENSIONS (50/60 Hz)

e-SV SERIES - REDUCED DIMENSIONS 50/60 Hz

Background and context

In industry or in the building services market, reducing room of pumping equipment is one of the main goals of architects and manufacturing layout designers. They look for compact solutions which help to save space on installation, such as compact water supply installation, compact water booster sets and closed loop circuits. Therefore Lowara has developed e-SV Reduced dimensions: a pump or booster set which delivers a compact and original solution to the most critical footprint size.

Benefits of e-SV Reduced dimensions

Compact design: e-SV Reduced dimensions offers up to 50% saving in the plant room dedicated usually for a traditional vertical multistage pump with suction and discharge ports designed inline.

Versatile design: e-SV Reduced dimensions offers many different configurations with the delivery port above the suction port with 4 adjustable positions. This specific design of the pump allows installing e-SV Reduced dimensions everywhere, even at a close proximity to a wall.

High level performances: e-SV Reduced dimensions keeps the same level of performances of the e-SV range from size 1SV to 22SV. e-SV Reduced dimensions is available with round flanges up to PN25.

Code identification

e-SV Reduced dimensions design is identified with a "R" in the product codification of the whole e-SV range.

Example: 3SV13R015T

R = Reduced dimensions.



Special features / product benefits

- Specific superposed design of the inlet and outlet allowing savings in up to 50% space.
- **Standard mechanical seal** (EN12756) fitted on all models. **Easy to replace without removing the motor** from 5,5 kW up.
- **Hard material intermediate bush bearing** (Tungsten Carbide) to improve life and ability to withstand heavy duty application on all sizes.
- **Balanced impeller design** to reduce axial thrust for longer standard motor bearing life.
- Wide range of size to cover all requested duty points: from 1SV to 22SV.
- **IE2** efficiency level (three-phase 0,12-0,749 kW), **IE3** efficiency level (three-phase 0,75 to 1000 kW) **standard motors**, 2-poles with blocked bearing **to support maximum thrust without limiting inlet pressure.**

Special configurations

- e-SV Reduced dimensions offers the same range of configuration of the standard e-SV series.
- Materials used: see the Materials section.
- Options for mechanical seals and gaskets: see the mechanical seals and gaskets section.
- Options for motors and configuration: see the motors section.
- HYDROVAR™ system included.

**e-SV SERIES - REDUCED DIMENSIONS
HYDRAULIC PERFORMANCE TABLE AT 50 Hz, 2 POLES**

PUMP TYPE	RATED POWER		MEI ≥
	kW	HP	
1SV07	0,37	0,5	0,70
1SV08	0,55	0,75	0,70
1SV09	0,55	0,75	0,70
1SV10	0,55	0,75	0,70
1SV11	0,55	0,75	0,70
1SV12	0,75	1	0,70
1SV13	0,75	1	0,70
1SV15	0,75	1	0,70
1SV17	1,1	1,5	0,70
1SV19	1,1	1,5	0,70
1SV22	1,1	1,5	0,70
1SV25	1,5	2	0,70
1SV27	1,5	2	0,70
1SV30	1,5	2	0,70
1SV32	2,2	3	0,70
1SV34	2,2	3	0,70
1SV37	2,2	3	0,70

3SV07	0,75	1	0,70
3SV08	0,75	1	0,70
3SV09	1,1	1,5	0,70
3SV10	1,1	1,5	0,70
3SV11	1,1	1,5	0,70
3SV12	1,1	1,5	0,70
3SV13	1,5	2	0,70
3SV14	1,5	2	0,70
3SV16	1,5	2	0,70
3SV19	2,2	3	0,70
3SV21	2,2	3	0,70
3SV23	2,2	3	0,70
3SV25	2,2	3	0,70
3SV27	3	4	0,70
3SV29	3	4	0,70
3SV31	3	4	0,70
3SV33	3	4	0,70

5SV07	1,1	1,5	0,70
5SV08	1,1	1,5	0,70
5SV09	1,5	2	0,70
5SV10	1,5	2	0,70
5SV11	1,5	2	0,70
5SV12	2,2	3	0,70
5SV13	2,2	3	0,70
5SV14	2,2	3	0,70
5SV15	2,2	3	0,70
5SV16	2,2	3	0,70
5SV18	3	4	0,70
5SV21	3	4	0,70
5SV23	4	5,5	0,70
5SV25	4	5,5	0,70
5SV28	4	5,5	0,70
5SV30	5,5	7,5	0,70
5SV33	5,5	7,5	0,70

PUMP TYPE	RATED POWER		MEI ≥
	kW	HP	
10SV05	2,2	3	0,70
10SV06	2,2	3	0,70
10SV07	3	4	0,70
10SV08	3	4	0,70
10SV09	4	5,5	0,70
10SV10	4	5,5	0,70
10SV11	4	5,5	0,70
10SV13	5,5	7,5	0,70
10SV15	5,5	7,5	0,70
10SV17	7,5	10	0,70
10SV18	7,5	10	0,70
10SV20	7,5	10	0,70
10SV21	11	15	0,70

15SV04	4	5,5	0,70
15SV05	4	5,5	0,70
15SV06	5,5	7,5	0,70
15SV07	5,5	7,5	0,70
15SV08	7,5	10	0,70
15SV09	7,5	10	0,70
15SV10	11	15	0,70
15SV11	11	15	0,70
15SV13	11	15	0,70
15SV15	15	20	0,70
15SV17	15	20	0,70

22SV04	4	5,5	0,70
22SV05	5,5	7,5	0,70
22SV06	7,5	10	0,70
22SV07	7,5	10	0,70
22SV08	11	15	0,70
22SV09	11	15	0,70
22SV10	11	15	0,70
22SV12	15	20	0,70
22SV14	15	20	0,70
22SV17	18,5	25	0,70

Q = DELIVERY
H = HEAD
Pp = POWER
np = EFFICIENCY

For hydraulic performance values, consult the standard e-SV™ catalogue

HORIZONTAL INSTALLATION (50/60 Hz)

e-SV SERIES - HORIZONTAL INSTALLATION 50/60 Hz

Background and context

In some applications where room is reduced vertically, it is mandatory to have some pumps systems able to deliver high pressure performances together with a limited occupied vertical space. Therefore Lowara proposes the full range of e-SV in the horizontal position: a pump which delivers from a vertical space saving solution together with the high performance of the e-SV series.

Benefits of e-SV Horizontal

Reduced use of the vertical space: e-SV Horizontal reduces the space usually used vertically by the traditional vertical multistage pumps thanks to a specific range of accessories which allows the installation of the pump in a horizontal position.

Easy installation: any e-SV pumps can be installed in a horizontal position. Lowara has developed some specific accessories, which according to the pump model and motor, allow any e-SV multi-stage vertical pump to be installed horizontally.

Motor construction design: the horizontal installation is available for **motor with V18/B14 or V1/B5 construction design** (up to 11 kW), **B35 construction design** (from 15 kW and above).

Code identification

There is no specific code identification for e-SV Horizontal, since it's a different installation of the standard e-SV series.

Special features / product benefits

By being a different installation of the e-SV series, the special features and products benefits of e-SV Horizontal are the same as the standard e-SV series.

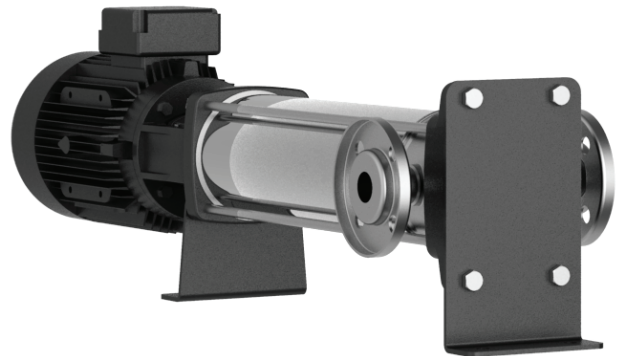

Special configurations

e-SV Horizontal offers the same range of configuration of the standard e-SV series:

- Materials used: see the Materials section.
- Options for mechanical seals and gaskets: see the mechanical seals and gaskets section.
- Options for motors and configuration: see the motors section.
- e-SV version with discharge port above suction (**e-SV.R**)
- HYDROVAR™ system included.

Operating characteristics

For hydraulic performance values, consult the standard e-SV catalogue.

NOTE (50 Hz)

For information relative to the MEI index, hydraulic performance (Q, H, Pp, np) and anything other points concerning Regulation (EU) n. 547/2012, consult the standard e-SV catalogue.

1-22SV - HORIZONTAL INSTALLATION (For dimensions L1, L2, M, ØD1, consult the standard e-SV catalogue).

1, 3, 5SV (F-N VERSIONS)

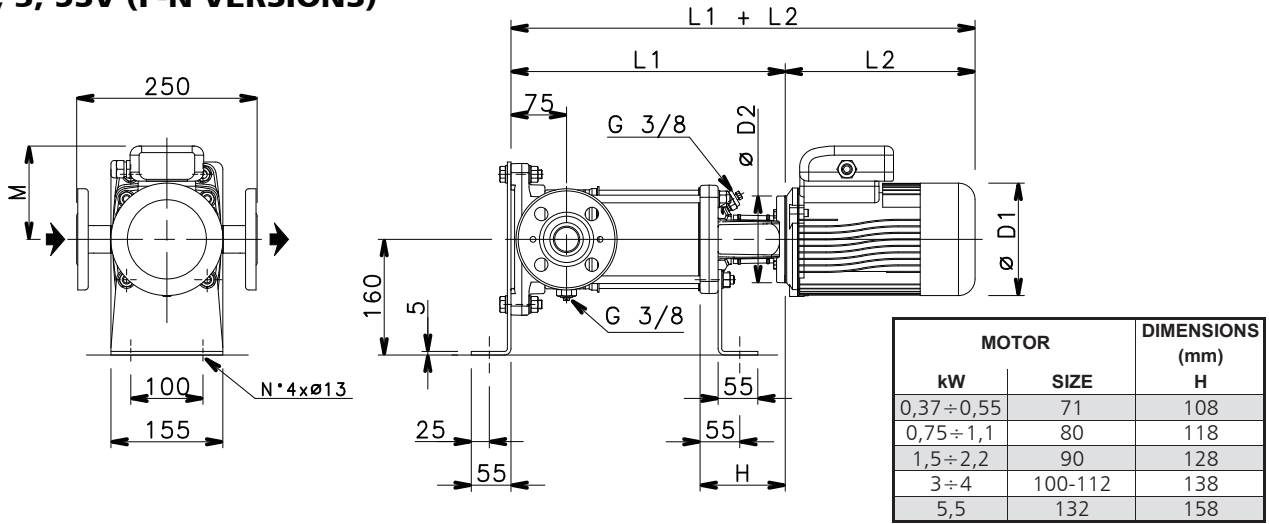

059070R_B_DD

1-5svor-2p50-en_a_td

10, 15, 22SV (F-N VERSIONS) (0,75 ÷ 11 kW)

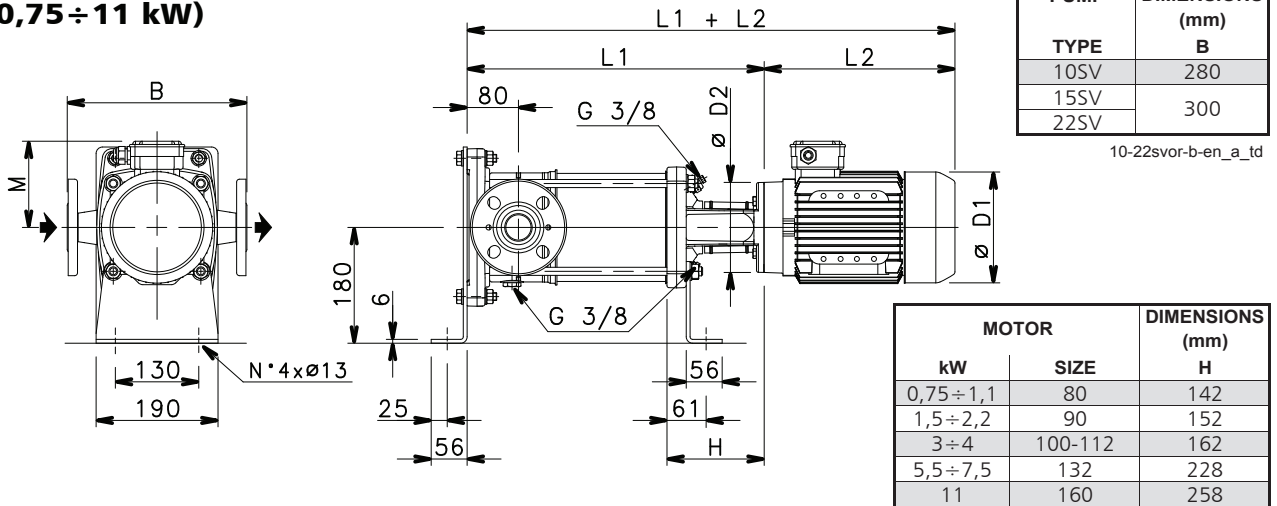

059080R_B_DD

10-22svor-2p50-en_a_td

15, 22SV (F-N VERSIONS) (15 ÷ 18,5 kW)

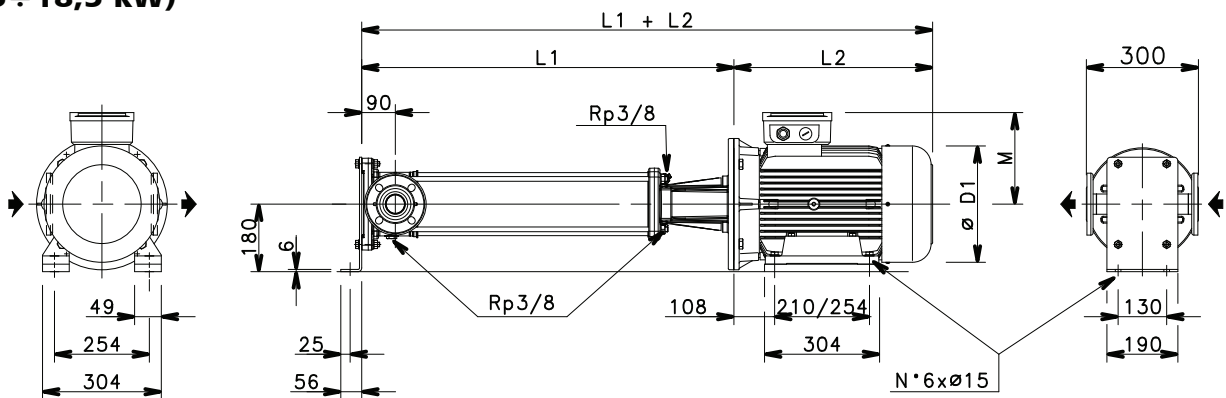

059090R_B_DD

33-92SV - HORIZONTAL INSTALLATION (For dimensions L1, L2, M, ØD1, consult the standard e-SV catalogue).

33, 46, 66, 92SV (G-N VERSIONS) (1,1 ÷ 11 kW)

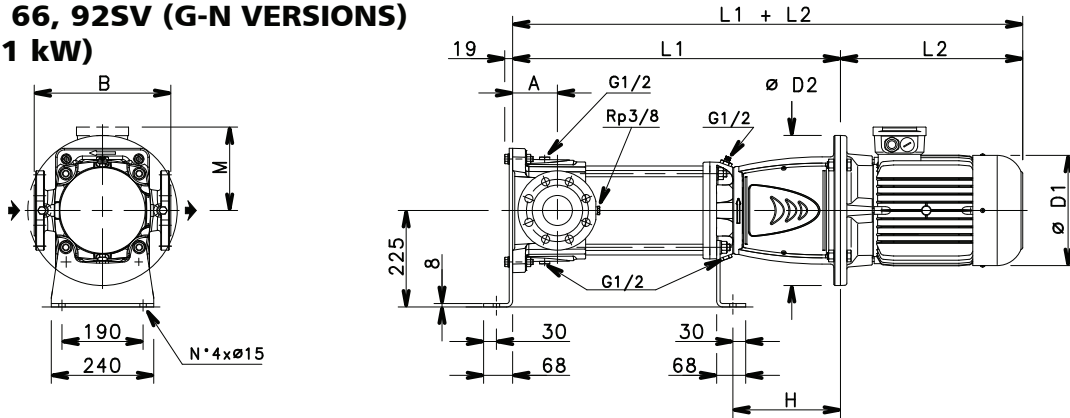

PUMP TYPE	DIMENSIONS (mm)	
	A	B
33SV	105	320
46-66-92SV	140	365

kW	MOTOR SIZE	DIMENSIONS (mm)	
		H	
1,1 ÷ 4	90-100-112	196	
5,5 ÷ 7,5	132	216	
11	160	251	

05108_C_DD

33-92svo-11kw-2p50-en_a_td

33, 46, 66, 92SV (G-N VERSIONS) (15 ÷ 22 kW)

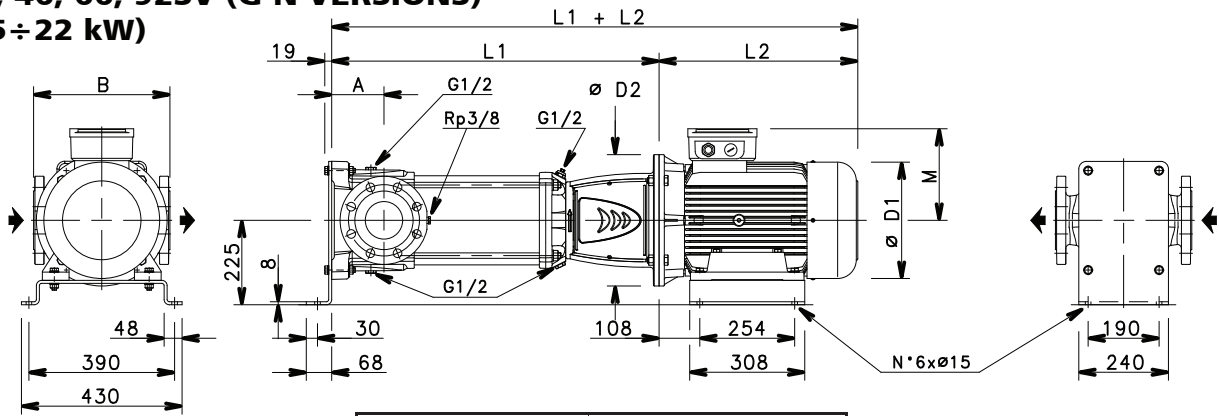

PUMP TYPE	DIMENSIONS (mm)	
	A	B
33SV	105	320
46-66-92SV	140	365

05109_C_DD

33-92svo-22kw-2p50-en_a_td

33, 46, 66, 92SV (G-N VERSIONS) (30 ÷ 45 kW)

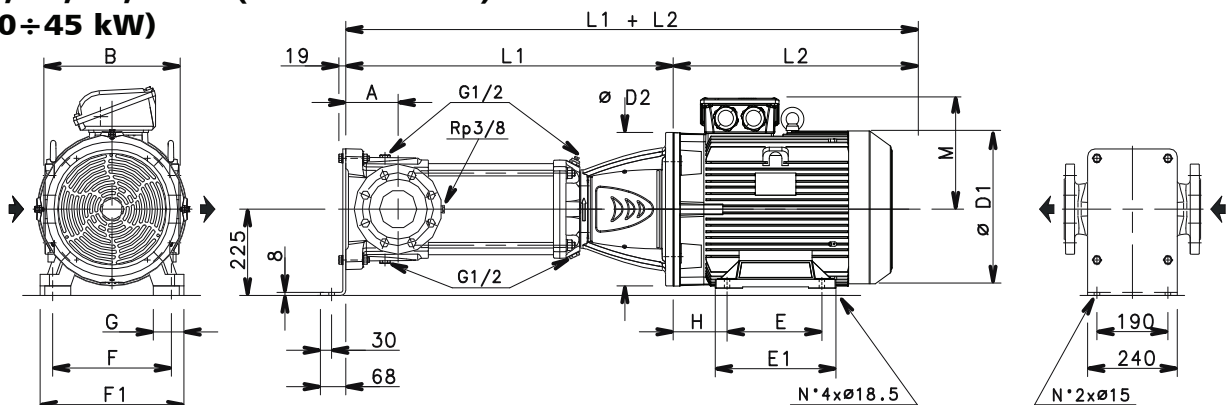

PUMP TYPE	DIMENSIONS (mm)	
	A	B
33SV	105	320
46-66-92SV	140	365

kW	MOTOR SIZE	DIMENSIONS (mm)					
		H	E	E1	F	F1	G
30 ÷ 37	200	133	305	355	318	408	69
45	225	149	311	361	356	470	84

05109C_D_DD

33-92svo-45kw-2p50-en_c_td

125SV - HORIZONTAL INSTALLATION (For dimensions L1, L2, M, ØD1, consult the standard e-SV catalogue).

125SV (G-N VERSIONS) (7,5 kW)

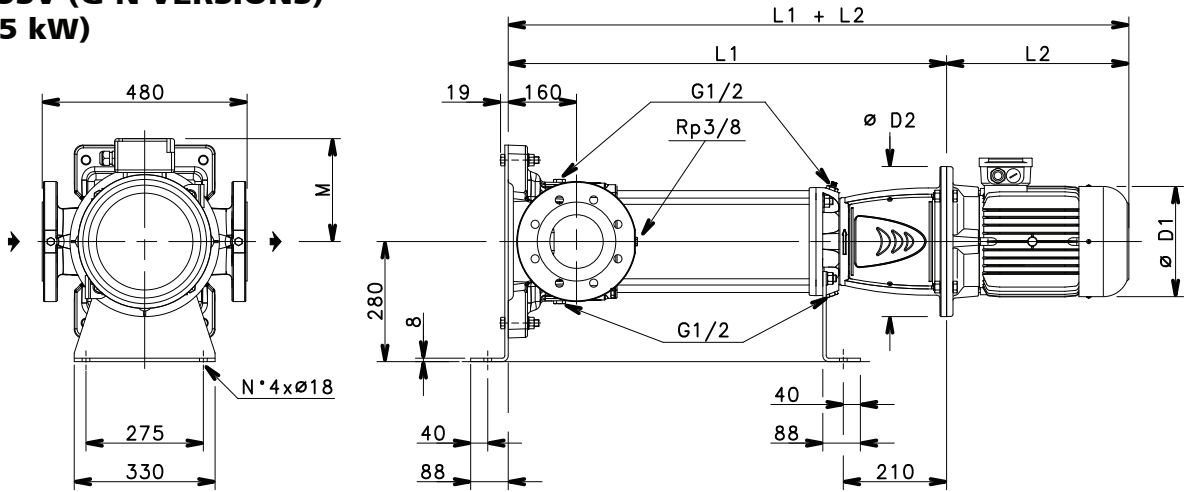

059110R_B_DD

125SV (G-N VERSIONS) (15÷45 kW)

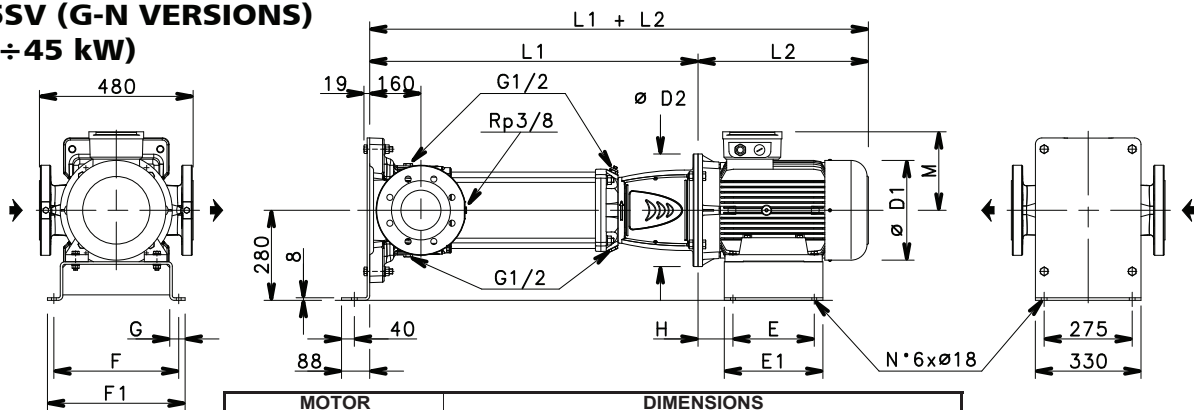

MOTOR		DIMENSIONS (mm)					
kW	SIZE	H	E	E1	F	F1	G
15	160	108	254	304	390	430	53
22	180	108	254	304	390	430	53
30÷37	200	133	305	370	465	505	53
45	225	149	311	412	515	565	58

059150R_B_DD

125svor-15-45kw-2p50-en_a_td

125SV (G-N VERSIONS) (55 kW)

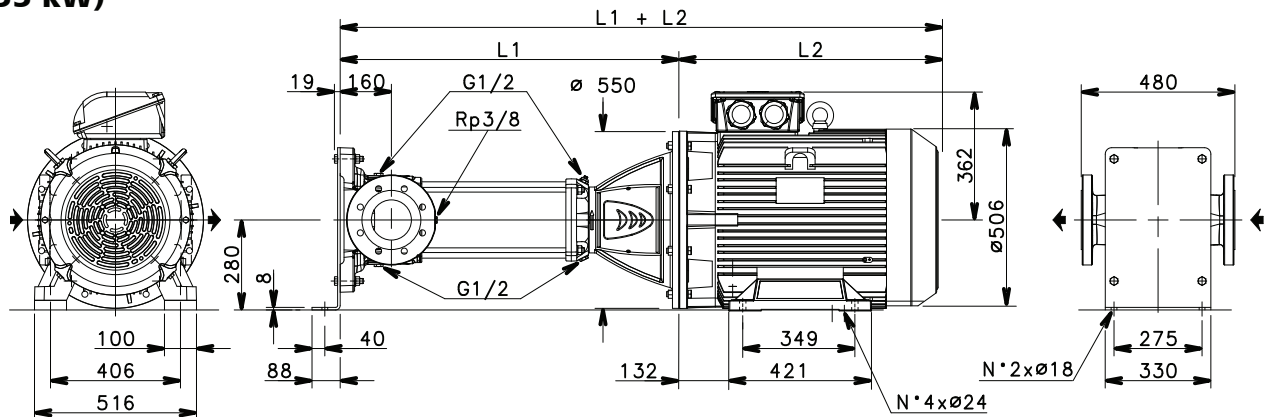

059230R_C_DD

MOTORS

(50/60 Hz)

e-SV SERIES MOTORS AT 50 Hz (ErP 2009/125/EC)

From 1 July 2021 in accordance with the **Regulations (EU) 2019/1781 and 2021/341**, the three-phase 50 Hz, 60 Hz or 50/60 Hz **surface motors** with **power outputs ranging from 0,12 to 0,749 kW** must have a minimum level **IE2** efficiency; the ones with power outputs ranging **from 0,75 and 1000 kW** must have a minimum level of **IE3** efficiency.

From 1 July 2023, it will be introduced additional requirements.

The following tables also contain the mandatory information pursuant to Annex I, section 2, of the aforementioned Regulations.

- Short-circuit squirrel-cage motor, enclosed construction with external ventilation (TEFC).
- **IP55** protection degree.
- Insulation class **155 (F)**.
- Electrical performances according to EN 60034-1.
- **Supplied three-phase surface motors with IE2 efficiency level (for power < 0,75 kW) or IE3 efficiency level (for power ≥ 0,75 kW) as standard according to EN 60034-30:2009 and EN 60034-30-1:2014.**
- Metric cable gland according to EN 50262.
- PTC included in motors from 30 to 55 kW (one per phase, 155°C).

Single-phase version:

220-240 V 50 Hz

Built-in automatic reset overload protection up to 1,5 kW. For higher powers the protection must be provided by the user.

Maximum ambient temperature: 40 °C.

• Three-phase version:

220-240/380-415 V 50 Hz for power up to 3 kW.

380-415/660-690 V 50 Hz for power above 3 kW.

Overload protection to be provided by the user.

Maximum ambient temperature: 40°C or 50 °C, (depending on model and power)

Standard options surface motors

In addition to a wide range of motors and special voltages, Lowara offers a wide range of standard options to cover all applications linked with the installation of the vertical multistage pumps e-SV:

Motor protection (three-phase)

PT100 temperature sensors (linear) in the windings

PTC temperature sensors in the windings

PTO bimetal thermal protectors in the windings

PTC in the bearings (only for larger motors)

Installation in harsh environments

Ambient temperature > 40°C (max. 60°C)

Protected to IP56 or IP65

Anti-condensation heaters

Tropicalisation

Protective canopy

Certification for marine use

Potentially explosive atmosphere (ATEX)

We reserve the right to supply motors from other brand to satisfy some of the requests.

SINGLE-PHASE MOTORS AT 50 Hz, 2-POLE

P _N kW	MOTOR TYPE	IEC SIZE*	Construction Design	INPUT CURRENT		CAPACITOR		DATA FOR 230 V 50 Hz VOLTAGE						OPERATING CONDITIONS **		
				In (A)	220-240 V	μF	V	min ⁻¹	Is / In	η %	cosφ	Tn Nm	Ts/Tn	Tm/Tn	Altitude asl m	T. amb min/max °C
0,37	SM71RB14/104	71R	V18/B14	2,79-2,85	14	450	2745	2,64	65,1	0,96	1,39	0,68	1,63	≤ 1000	-15/40	No
0,55	SM71B14/105	71		3,76-3,99	16	450	2820	3,72	68,9	0,91	1,86	0,61	2,00			
0,75	SM80RB14/107	80R		4,90-4,85	20	450	2765	3,42	70,1	0,96	2,59	0,58	1,75			
1,1	SM80B14/111	80		6,88-6,65	30	450	2800	3,89	74,7	0,96	3,75	0,46	1,72			
1,5	SM90RB14/115	90R		9,21-8,58	40	450	2810	4,00	76,1	0,98	5,09	0,39	1,74			
2,2	PLM90B14/122	90		12,5-11,6	70	450	2825	4,47	82,4	0,97	7,43	0,53	1,87			

* R = Reduced size of motor casing as compared to shaft extension and flange.

1-22sv-motm_2p50-en_c_te

** Operating conditions related only to the motor. For the electric pump refer to the IOM.

e-SV SERIES

THREE-PHASE MOTORS AT 50 Hz, 2-POLE (up to 22 kW)

P _N kW	Manufacturer		IEC SIZE*	Construction Design	N. of Poles	f _N Hz	Data for 400 V / 50 Hz Voltage				
	Xylem Service Italia Srl Reg. No. 07520560967 Montecchio Maggiore Vicenza - Italia						cosφ	I _s / I _N	T _N Nm	T _s /T _N	T _m /T _N
	Model										
0,37	SM71RB14/304		71R	V18/B14	2	50	0,64	4,35	1,37	4,14	4,10
0,55	SM71B14/305		71				0,71	6,25	1,84	3,96	3,97
0,75	SM80B14/307 PE		80				0,78	7,38	2,48	3,57	3,75
1,1	SM80B14/311 PE		80				0,79	8,31	3,63	3,95	3,95
1,5	SM90RB14/315 PE		90R				0,80	8,80	4,96	4,31	4,10
2,2	PLM90B14/322 E3		90				0,80	8,77	7,28	3,72	3,70
3	PLM100RB14/330 E3		100R				0,79	7,81	9,93	4,26	3,94
4	PLM112RB14S6/340 E3		112R				0,85	9,13	13,2	3,82	4,32
5,5	PLM132RB5/355 E3		132R				0,85	10,5	18,1	4,74	5,11
7,5	PLM132B5/375 E3		132				0,85	10,2	24,4	3,43	4,76
11	PLM160RB5/3110 E3		160R				0,86	9,89	35,9	3,46	4,59
15	PLM160B5/3150 E3		160				0,88	9,51	48,6	2,73	4,32
18,5	PLM160B5/3185 E3		160				0,88	9,81	59,9	2,81	4,53
22	PLM180RB5/3220 E3		180R				0,85	10,9	71,1	3,26	5,12

P _N kW	Voltage U _N V											n _N min ⁻¹	Operating conditions **		
	Δ			Y			Δ			Y			Altitude Above Sea Level (m)	T. amb min/max °C	ATEX
	220 V	230 V	240 V	380 V	400 V	415 V	380 V	400 V	415 V	660 V	690 V				
	I _N (A)														
0,37	2,03	2,18	2,32	1,17	1,26	1,34	-	-	-	-	-	2745 ÷ 2800	≤ 1000	-15 / 40	No
0,55	2,46	2,49	2,56	1,42	1,44	1,48	-	-	-	-	-	2835 ÷ 2865			
0,75	2,96	2,94	2,96	1,71	1,70	1,71	1,70	1,69	1,70	0,98	0,98	2875 ÷ 2895			
1,1	4,19	4,14	4,16	2,42	2,39	2,40	2,41	2,38	2,38	1,39	1,37	2870 ÷ 2900			
1,5	5,56	5,49	5,51	3,21	3,17	3,18	3,21	3,18	3,19	1,85	1,84	2870 ÷ 2895			
2,2	7,97	7,90	7,98	4,6	4,56	4,61	4,57	4,54	4,57	2,64	2,62	2880 ÷ 2900			
3	11,0	11,0	11,2	6,35	6,33	6,44	6,29	6,27	6,34	3,63	3,62	2865 ÷ 2895			
4	13,6	13,4	13,4	7,87	7,75	7,74	7,80	7,62	7,61	4,50	4,40	2885 ÷ 2910			
5,5	18,1	17,9	18,1	10,4	10,4	10,4	10,6	10,5	10,7	6,10	6,05	2880 ÷ 2910			
7,5	24,8	24,4	24,3	14,3	14,1	14,0	14,4	14,1	14,2	8,32	8,16	2920 ÷ 2935			
11	35,7	35,0	34,9	20,6	20,2	20,2	20,6	20,2	20,2	11,9	11,7	2910 ÷ 2930			
15	47,6	46,1	45,2	27,5	26,6	26,1	27,5	26,6	26,1	15,9	15,3	2940 ÷ 2950			
18,5	58,3	56,7	55,6	33,7	32,7	32,1	34,0	33,0	32,7	19,6	19,0	2940 ÷ 2950			
22	72,9	73,1	73,7	42,1	42,2	42,6	40,9	40,4	40,6	23,6	23,3	2950 ÷ 2960			

P _N kW	Efficiency η _N %																		IE
	Δ 220 V			Δ 230 V			Δ 240 V			Δ 380 V			Δ 400 V			Δ 415 V			
	Y 380 V			Y 400 V			Y 415 V			Y 660 V			Y 690 V						
	4/4	3/4	2/4	4/4	3/4	2/4	4/4	3/4	2/4	4/4	3/4	2/4	4/4	3/4	2/4	4/4	3/4	2/4	
0,37	70,4	73,2	68,9	70,4	70,3	64,5	70,4	67,2	60,2	-	-	-	-	-	-	-	-	-	2
0,55	74,1	74,2	70,4	74,1	73,6	68,8	74,1	72,7	67,1	-	-	-	-	-	-	-	-	-	
0,75	82,5	83,1	81,3	82,8	82,7	80,1	82,6	82,0	78,9	82,5	82,0	78,9	82,5	82,0	78,9	82,5	82,0	78,9	
1,1	84,0	84,7	83,4	84,4	84,5	82,5	84,3	84,0	81,4	84,0	84,0	81,4	84,0	84,0	81,4	84,0	84,0	81,4	
1,5	85,6	86,5	85,8	85,9	86,4	84,9	86,0	86,0	84,0	85,6	86,0	84,0	85,6	86,0	84,0	85,6	86,0	84,0	
2,2	86,5	87,4	86,8	86,4	86,9	85,7	86,6	86,7	85,0	86,4	86,7	85,0	86,4	86,7	85,0	86,4	86,7	85,0	
3	87,2	88,5	88,3	87,5	88,2	87,5	87,5	87,8	86,4	87,2	87,8	86,4	87,2	87,8	86,4	87,2	87,8	86,4	
4	89,1	90,1	89,2	89,1	90,1	89,2	89,1	90,1	89,2	89,1	90,3	90,4	89,6	90,4	89,9	89,6	90,1	89,2	
5,5	89,5	89,6	88,0	89,5	89,6	88,0	89,5	89,6	88,0	89,5	90,3	89,9	89,7	90,0	89,0	89,6	89,6	88,0	
7,5	90,6	90,5	89,0	90,6	90,5	89,0	90,6	90,5	89,0	90,6	91,0	90,2	90,8	90,8	89,6	90,7	90,5	89,0	
11	91,3	92,0	91,1	91,3	92,0	91,1	91,3	92,0	91,1	91,3	92,2	92,2	91,6	92,2	91,7	91,7	92,0	91,1	
15	92,5	92,4	91,2	92,5	92,4	91,2	92,5	92,4	91,2	92,7	93,3	92,9	93,1	93,3	92,7	92,5	92,4	91,2	
18,5	92,6	93,1	92,4	92,6	93,1	92,4	92,6	93,1	92,4	92,6	93,2	93,0	92,9	93,3	92,8	92,9	93,1	92,4	
22	93,0	92,7	91,3	93,0	92,7	91,3	93,0	92,7	91,3	93,0	93,2	92,4	93,1	93,0	91,9	93,0	92,7	91,3	

* R = Reduced size of motor casing as compared to shaft extension and flange.

sv-IE3-mott22-2p50-en_c_te

** Operating conditions to be referred to motor only. About electric pump, refer to limits in user's manual.

e-SV SERIES

THREE-PHASE MOTORS AT 50 Hz, 2-POLE (from 30 to 55 kW)

P _N kW	Manufacturer	IEC SIZE	Construction Design	N. of Poles	f _N Hz	Data for 400 V / 50 Hz Voltage				
	OMEGA MOTOR SANAYI A.S. Dudullu Organize Sanayi Bölgesi 2. Cadde No: 10 34775 Ümraniye ISTANBUL/TURKEY Reg. No. 913733					Model	cosφ	I _s / I _N	T _N Nm	T _s /T _N
30	3MAS 200LA2 V1 30KW E3	200	V1	2	50	0,89	7,80	96,90	2,60	3,10
37	3MAS 200LB2 V1 37KW	200				0,90	8,00	119,4	2,90	3,20
45	3MAS 225M2 V1 45KW E3	225				0,91	8,20	144,4	2,70	3,30
55	3MGS 250M2 V1 55KW E3	250				0,90	7,60	176,4	2,50	3,00

P _N kW	Voltage U _N V					n _N min ⁻¹	Operating conditions **		
	Δ			Y			Altitude Above Sea Level (m)	T. amb min/max °C	ATEX
	380 V	400 V	415 V	660 V	690 V				
	I _N (A)								
30	55,3	52,2	50,8	31,8	30,3	2965	≤ 1000	-20 / 50	No
37	66,6	63,9	61,5	38,4	37,0	2965			
45	80,6	75,9	73,7	46,4	44,0	2975			
55	98,2	92,7	89,7	56,5	53,7	2975			

P _N kW	Efficiency η _N %									IE
	Δ 380 V Y 660 V			Δ 400 V Y 690 V			Δ 415 V			
	4/4	3/4	2/4	4/4	3/4	2/4	4/4	3/4	2/4	
30	93,0	93,1	93,0	93,3	93,5	93,4	93,4	93,6	93,4	3
37	93,5	94,0	93,7	93,7	94,1	93,8	93,8	94,2	93,9	
45	93,8	94,0	93,5	94,0	94,2	93,6	94,2	94,4	93,8	
55	93,8	94,0	93,9	94,3	94,6	94,5	94,4	94,7	94,5	

** Operating conditions to be referred to motor only. About electric pump, refer to limits in user's manual.

sv-IE3-mott55-2p50-en_c_te

Note: Observe the regulations and codes locally in force regarding sorted waste disposal.

e-SV SERIES

THREE-PHASE MOTORS AT 50 Hz, 4-POLE

P _N kW	Manufacturer		IEC SIZE	Construction Design	N. of Poles	f _N Hz	Data for 400 V / 50 Hz Voltage				
	Xylem Service Italia Srl Reg. No. 07520560967 Montecchio Maggiore Vicenza - Italia						cosφ	I _s / I _N	T _N Nm	T _s /T _N	T _m /T _N
	Model										
0,25	LLM471B14/302		71	V18/B14	4	50	0,77	3,90	1,80	1,80	2,00
0,37	LLM471B14/304		71				0,70	4,60	2,60	2,70	2,20
0,55	LLM480B14/305		80				0,76	4,40	3,80	2,30	2,40
0,55	LLM480B14S2/305		80				0,72	1,69	3,80	0,60	0,63
0,75	LLM480B14/307		80				0,75	5,78	5,03	2,77	3,31
1,1	PLM490B14/311		90				0,71	5,87	7,32	2,47	3,09
1,5	PLM490B14/315		90				0,68	6,63	9,93	2,96	3,60
2,2	PLM4100B14/322		100				0,79	6,95	14,50	2,14	3,31
3	PLM4100B14/330		100				0,75	7,32	19,70	2,24	3,78
4	PLM4112B14/340		112				0,79	8,32	26,30	3,19	4,02
5,5	PLM4132B5/355		132	V1/B5			0,76	7,64	35,90	2,85	3,65
7,5	PLM4132B5/375		132				0,79	7,70	49,09	2,69	3,57

P _N kW	Voltage U _N V											η _N min ⁻¹	Operating conditions **		
	Δ			Y			Δ			Y			Altitude Above Sea Level (m)	T. amb min/max °C	ATEX
	220 V	230 V	240 V	380 V	400 V	415 V	380 V	400 V	415 V	660 V	690 V				
	I _N (A)														
0,25	1,28	1,21	1,16	0,74	0,70	0,67	-	-	-	-	-	1390	≤ 1000	-15 / 40	No
0,37	1,82	1,73	1,66	1,05	1,00	0,96	-	-	-	-	-	1410			
0,55	2,42	2,60	2,25	1,40	1,35	1,30	-	-	-	-	-	1420			
0,75	3,08	3,03	3,01	1,78	1,75	1,74	1,78	1,75	1,74	1,03	1,01	1410 ÷ 1430			
1,1	4,61	4,59	4,62	2,66	2,65	2,67	2,64	2,63	2,65	1,53	1,52	1435 ÷ 1445			
1,5	6,34	6,41	6,41	3,66	3,70	3,70	3,65	3,68	3,69	2,11	2,13	1440 ÷ 1450			
2,2	8,19	8,04	7,97	4,73	4,64	4,60	4,70	4,62	4,56	2,71	2,67	1445 ÷ 1455			
3	11,5	11,5	11,6	6,66	6,62	6,67	6,63	6,59	6,63	3,83	3,81	1455 ÷ 1465			
4	14,8	14,6	14,5	8,52	8,40	8,36	8,40	8,23	8,19	4,85	4,78	1445 ÷ 1455			
5,5	20,0	19,7	19,4	11,6	11,4	11,2	11,7	11,5	11,4	6,75	6,62	1455 ÷ 1465			
7,5	26,6	26,1	25,8	15,4	15,1	14,9	15,5	15,2	15,1	8,95	8,75	1450 ÷ 1460			

P _N kW	Efficiency η _N %																		IE
	Δ 220 V Y 380 V			Δ 230 V Y 400 V			Δ 240 V Y 415 V			Δ 380 V Y 660 V			Δ 400 V Y 690 V			Δ 415 V			
	4/4	3/4	2/4	4/4	3/4	2/4	4/4	3/4	2/4	4/4	3/4	2/4	4/4	3/4	2/4	4/4	3/4	2/4	
0,25	70,6	72,5	70,8	70,9	71,5	69,0	71,8	71,5	67,1	-	-	-	-	-	-	-	-	-	2
0,37	75,9	76,0	72,0	75,8	74,6	70,1	75,2	73,4	68,1	-	-	-	-	-	-	-	-	-	
0,55	78,8	80,3	78,9	79,0	79,7	77,6	79,6	79,6	76,7	-	-	-	-	-	-	-	-	-	3
0,75	80,4	81,3	79,8	81,1	81,4	79,1	81,4	81,2	78,4	80,4	81,2	78,4	80,4	81,2	78,4	80,4	81,2	78,4	
1,1	84,9	85,7	84,7	85,3	85,5	83,8	85,3	85,0	82,7	84,9	85,0	82,7	84,9	85,0	82,7	84,9	85,0	82,7	
1,5	86,6	87,0	85,7	86,7	86,9	84,5	86,4	85,9	83,3	86,4	85,9	83,3	86,4	85,9	83,3	86,4	85,9	83,3	
2,2	87,6	88,6	88,3	88,2	88,8	87,9	88,5	88,7	87,4	87,6	88,6	87,4	87,6	88,6	87,4	87,6	88,6	87,4	
3	88,5	89,2	88,5	88,6	88,9	87,6	88,6	88,6	86,8	88,5	88,6	86,8	88,5	88,6	86,8	88,5	88,6	86,8	
4	88,6	89,1	87,9	88,6	89,1	87,9	88,6	89,1	87,9	88,6	89,2	88,9	88,6	89,2	88,4	88,8	89,1	87,9	
5,5	90,4	90,9	89,7	90,4	90,9	89,7	90,4	90,9	89,7	90,4	91,0	90,5	90,9	91,1	90,2	90,9	90,9	89,7	
7,5	90,4	91,2	90,4	90,4	91,2	90,4	90,4	91,2	90,4	90,4	91,2	91,1	90,7	91,3	90,8	90,9	91,2	90,4	

** Operating conditions to be referred to motor only. About electric pump, refer to limits in user's manual.

sv-ie2-mott15-4p50-en_d_te

e-SV SERIES MOTORS AT 60 Hz (ErP 2009/125/EC)

Standard supplied SV electric pumps are equipped with standard motors.

- **Supplied three-phase surface motors with IE2 efficiency level (for power < 0,75 kW) or IE3 efficiency level (for power ≥ 0,75 kW) as standard according to EN 60034-30:2009 and EN 60034-30-1:2014.**
- Short-circuit squirrel-cage motor, enclosed construction with external ventilation (TEFC).
- IP55 protection degree.
- Insulation class 155 (F).
- Electrical performances according to EN 60034-1.
- Cable gland with metric according to EN 50262.
- PTC included in motors from 30 to 55 kW.
- **Single-phase** version:
220-230 V 60 Hz
with built-in automatic reset overload protection up to 1,5 kW. For higher powers the protection must be provided by the user.
- **Three-phase** version:
220 V Δ, 380 V Y, 60 Hz up to 55 kW.
Overload protection to be provided by the user.

Standard options surface motors

In addition to a wide range of motors and special voltages, Lowara offers a wide range of standard options to cover all applications linked with the installation of the vertical multistage pumps e-SV:

High efficiency

Availability of UL (cURus) motor version for North American market (three-phase motors at 60 Hz).
The UL motors meet the requirements of the Premium Efficiency of US Department of Energy.

Installation in harsh environments

Ambient temperature > 40°C (max. 60°C)
Protected to IP56 or IP65
Anti-condensation heaters
Tropicalisation
Protective canopy
Certification for marine use
Potentially explosive atmosphere (ATEX)

Approvals

UL recognized
CSA

Motor protection (three-phase)

PT100 temperature sensors (linear) in the windings
PTC temperature sensors in the windings
PTO bimetal thermal protectors in the windings
PTC in the bearings (only for larger motors)

Other:

Electrically insulated bearings
Increased service factor (S.F. 1.15)

We reserve the right to supply motors from other brand to satisfy some of the requests.

SINGLE-PHASE MOTORS AT 60 Hz, 2-POLE

P _N kW	MOTOR TYPE	IEC SIZE*	Construction Design	INPUT		CAPACITOR		DATA FOR 220 V 60 Hz VOLTAGE						OPERATING CONDITIONS **		
				CURRENT I _n (A)	220-230 V	μF	V	min ⁻¹	Is / I _n	η %	cosφ	T _n Nm	T _s /T _n	T _m /T _n	Altitude asl m	T. amb min/max °C
0,4	SM71RB14/1046	71R	V18/B14	2,86-2,94	14	450	3385	3,8	67,5	0,94	1,13	0,73	2,04	1000	-15/40	No
0,55	SM71B14/1056	71		3,68-3,62	16	450	3400	4,28	70,2	0,97	1,54	0,66	2,11			
0,75	SM80RB14/1076	80R		4,98-4,88	20	450	3380	3,9	69,8	0,98	2,12	0,64	1,91			
1,1	SM80B14/1116	80		6,94-6,89	30	450	3435	4,54	74,2	0,97	3,06	0,62	2,03			
1,5	SM90RB14/1156	90R		9,28-9,35	40	450	3455	4,91	76,3	0,96	4,14	0,49	2,19			
2,2	PLM90B14/1226	90		12,3-11,7	60	450	3455	4,99	83,4	0,98	6,08	0,54	2,06			

* R = Reduced size of motor casing as compared to shaft extension and flange.

1-22sv-motm-2p60_en_e_te

** Operating conditions to be referred to motor only. About electric pump, refer to limits in user's manual.

e-SV SERIES

THREE-PHASE MOTORS AT 60 Hz, 2-POLE (up to 22 kW)

P _N kW	Manufacturer		IEC SIZE*	Construction Design	N. of Poles	f _N Hz	Data for 380 V / 60 Hz Voltage				
	Xylem Service Italia Srl Reg. No. 07520560967 Montecchio Maggiore Vicenza - Italia						cosφ	I _s / I _N	T _N Nm	T _s /T _N	T _m /T _n
	Model										
0,37	SM71RB14/304		71R	V18/B14	2	60	0,79	5,06	1,16	3,42	3,44
0,55	SM71B14/305		71				0,71	7,26	1,52	4,39	4,48
0,75	SM80B14/307 PE		80				0,79	8,25	2,05	3,80	4,02
1,1	SM80B14/311 PE		80				0,80	9,11	3,01	4,15	4,29
1,5	SM90RB14/315 PE		90R				0,82	9,79	4,10	4,36	4,37
2,2	PLM90B14/322 E3		90				0,82	9,80	6,01	3,80	4,01
3	PLM100RB14/330 E3		100R				0,82	9,35	8,21	4,26	4,10
4	PLM112RB14S6/340 E3		112R				0,87	10,0	10,9	2,43	4,53
5,5	PLM132RB5/355 E3		132R				0,88	12,0	15,0	4,70	5,55
7,5	PLM132B5/375 E3		132				0,87	11,0	20,2	3,31	4,98
11	PLM160RB5/3110 E3		160R				0,89	9,00	29,6	2,43	4,26
15	PLM160B5/3150 E3		160				0,89	9,81	40,3	2,79	4,41
18,5	PLM160B5/3185 E3		160				0,89	10,1	49,7	2,78	4,59
22	PLM180RB5/3220 E3		180R				0,87	11,3	59,1	3,27	5,18

P _N kW	Voltage U _N V								η _N min ⁻¹	Operating conditions **		
	Δ		Y		Δ		Y			Altitude above sea Level (m)	T. amb min/max °C	ATEX
	220 V	230 V	380 V	400 V	380 V	400 V	660 V	690 V				
	I _N (A)											
0,37	1,75	1,75	1,01	1,01	-	-	-	-	3290 ÷ 3335	1000 VI	-15 / 40	No
0,55	2,54	2,25	1,47	1,3	-	-	-	-	3465 ÷ 3475			
0,75	3,03	3,01	1,75	1,74	1,75	1,74	1,01	1,00	3490 ÷ 3500			
1,1	4,24	4,24	2,45	2,45	2,44	2,43	1,41	1,40	3490 ÷ 3505			
1,5	5,58	5,53	3,22	3,19	3,23	3,22	1,86	1,86	3485 ÷ 3505			
2,2	7,97	7,93	4,60	4,58	4,59	2,65	4,57	2,64	3490 ÷ 3505			
3	10,9	10,8	6,30	6,23	6,32	6,29	3,65	3,63	3485 ÷ 3500			
4	13,4	13,2	7,76	7,62	7,78	7,63	4,49	4,41	3510 ÷ 3520			
5,5	18,2	18,0	10,5	10,4	10,5	10,5	6,08	6,06	3505 ÷ 3515			
7,5	25,0	24,7	14,5	14,2	14,4	14,1	8,34	8,15	3535 ÷ 3540			
11	35,3	34,3	20,4	19,8	20,4	19,6	11,8	11,3	3545 ÷ 3555			
15	47,6	46,4	27,5	26,8	27,8	27,1	16,1	15,6	3550 ÷ 3560			
18,5	58,7	57,5	33,9	33,2	34,0	33,2	19,6	19,2	3550 ÷ 3555			
22	71,1	70,2	41,1	40,5	40,8	39,8	23,5	23,0	3555 ÷ 3560			

P _N kW	Efficiency η _N %												IE
	Δ 220 V Y 380 V			Δ 230 V Y 400 V			Δ 380 V Y 660 V			Δ 400 V Y 690 V			
	4/4	3/4	2/4	4/4	3/4	2/4	4/4	3/4	2/4	4/4	3/4	2/4	
0,37	72,0	70,8	64,0	72,0	70,8	64,0	-	-	-	-	-	-	2
0,55	74,0	72,8	66,4	74,0	72,8	66,4	-	-	-	-	-	-	
0,75	83,4	82,4	79,0	83,4	82,4	79,0	83,4	82,4	79,0	83,4	82,4	79,0	
1,1	85,6	85,0	82,1	85,6	85,0	82,1	85,6	85,0	82,1	85,6	85,0	82,1	
1,5	87,2	87,0	84,6	87,2	87,0	84,6	87,2	87,0	84,6	87,2	87,0	84,6	
2,2	87,7	87,2	84,7	87,7	87,2	84,7	87,7	87,2	84,7	87,7	87,2	84,7	
3	89,1	88,8	86,9	89,1	88,8	86,9	89,1	88,8	86,9	89,1	88,8	86,9	
4	91,0	91,0	89,6	91,0	91,0	89,6	91,0	91,0	89,6	91,0	91,0	89,6	
5,5	91,0	90,5	88,6	91,0	90,5	88,6	91,0	90,5	88,6	91,0	90,5	88,6	
7,5	90,8	90,2	88,1	90,8	90,2	88,1	90,8	90,2	88,1	90,8	90,2	88,1	
11	92,5	92,2	90,6	92,5	92,2	90,6	92,5	92,2	90,6	92,5	92,2	90,6	
15	93,4	93,1	91,7	93,4	93,1	91,7	93,4	93,1	91,7	93,4	93,1	91,7	
18,5	93,5	93,2	91,9	93,5	93,2	91,9	93,5	93,2	91,9	93,5	93,2	91,9	
22	93,4	92,7	90,8	93,4	92,7	90,8	93,4	92,7	90,8	93,4	92,7	90,8	

* R = Reduced size of motor casing as compared to shaft extension and flange.

sv-ie3-mott22-2p60-en_c_te

** Operating conditions to be referred to motor only. About electric pump, refer to limits in user's manual.

e-SV SERIES

THREE-PHASE MOTORS AT 60 Hz, 2-POLE (from 30 to 55 kW)

P _N kW	Manufacturer	IEC SIZE	Construction Design	N. of Poles	f _N Hz	Data for 380 V / 60 Hz Voltage				
	OMEGA MOTOR SANAYİ A.Ş. Dudullu Organize Sanayi Bölgesi 2. Cadde No: 10 34775 Ümraniye İSTANBUL/TURKEY Reg. No. 913733					cosφ	I _s / I _N	T _N Nm	T _s /T _N	T _m /T _N
30	3MAS 200LA2 V1 30KW E3	200	V1	2	60	0,90	7,60	80,4	2,40	2,90
37	3MAS 200LB2 V1 37KW E3	200				0,90	7,70	99,2	2,50	2,90
45	3MAS 225M2 V1 45KW E3	225				0,91	8,20	120,3	2,40	3,10
55	3MGS 250M2 V1 55KW E3	250				0,90	7,90	147,0	2,40	3,00

P _N kW	Voltage U _N V				n _N min ⁻¹	Operating conditions **		
	Δ	Y	Δ	Y		Altitude above sea Level (m)	T. amb min/max °C	ATEX
	220 V	380 V	380 V	660 V				
	I _N (A)							
30	94,6	54,8	54,8	31,6	3565	1000 VI	-20 / 50	No
37	115,9	67,1	67,2	38,7	3565			
45	138,3	80,1	80,3	46,2	3575			
55	171,3	99,2	99,2	57,1	3575			

P _N kW	Efficiency η _N %						IE
	Δ 220 V Y 380 V			Δ 380 V Y 660 V			
	4/4	3/4	2/4	4/4	3/4	2/4	
30	92,4	92,6	91,7	92,4	92,5	91,7	3
37	93,0	93,4	92,8	93,0	93,4	92,9	
45	93,6	93,9	93,0	93,6	93,9	92,9	
55	93,6	93,8	93,3	93,6	93,7	93,3	

** Operating conditions to be referred to motor only. About electric pump, refer to limits in user's manual.

e-SV SERIES
THREE-PHASE MOTORS AT 60 Hz, 4-POLE

P _N kW	Manufacturer		IEC SIZE	Construction Design	N. of Poles	f _N Hz	Data for 380 V / 60 Hz							
	Xylem Service Italia Srl Reg. No. 07520560967 Montecchio Magg. Vicenza - Italia						cosφ	I _s / I _N	T _N Nm	T _s /T _N	T _m /T _N			
	Model													
0,25	LLM471B14/302		71	V18/B14	4	60	0,72	4,50	1,00	1,90	2,00			
0,37	LLM471B14/304		71				0,60	6,50	2,00	3,50	3,70			
0,55	LLM480B14/305		80				0,76	5,00	3,02	2,70	2,90			
0,75	LLM480B14/307		80				0,75	6,26	4,14	2,82	3,53			
1,1	PLM490B14/311		90				0,70	6,55	6,02	2,50	3,52			
1,5	PLM490B14/315		90				0,69	7,34	8,18	2,99	4,10			
2,2	PLM4100B14/322		100				0,77	7,74	12,0	2,28	3,80			
3	PLM4100B14/330		100				0,74	8,18	16,3	2,35	4,39			
4	PLM4112B5/340		112				V1/B5			0,79	8,81	21,8	3,01	4,18
5,5	PLM4132B5/355		132							0,77	7,67	29,7	2,63	3,61
7,5	PLM4132B5/375		132	0,79	7,88	40,7				2,54	3,53			
11	PLM4160B5/3110		160	0,82	7,50	59,3				2,46	3,27			
15	PLM4160B5/3150		160	0,79	8,83	80,7				2,91	3,99			

P _N kW	Voltage U _N V								n _N min ⁻¹	Operating conditions **		
	Δ		Y		Δ		Y			Altitude abov. sea Level (m)	T. amb min/max °C	ATEX
	220 V	230 V	380 V	400 V	380 V	400 V	660 V	690 V				
	I _N (A)											
0,25	1,30	1,21	0,75	0,70	-	-	-	-	1700	1000 VI	-15 / 40	No
0,37	1,99	1,91	1,15	1,10	-	-	-	-	1725			
0,55	2,42	2,25	1,40	1,30	-	-	-	-	1740			
0,75	3,15	3,13	1,82	1,81	1,81	1,80	1,05	1,04	1730 ÷ 1735			
1,1	4,76	4,77	2,75	2,75	2,72	2,72	1,57	1,57	1745 ÷ 1750			
1,5	6,53	6,59	3,77	3,80	3,78	3,81	2,18	2,20	1750 ÷ 1755			
2,2	8,38	8,28	4,84	4,78	4,82	4,76	2,78	2,75	1755 ÷ 1760			
3	12,0	12,0	6,91	6,95	6,75	6,72	3,89	3,88	1760 ÷ 1765			
4	14,7	14,5	8,50	8,39	8,46	8,35	4,89	4,82	1755 ÷ 1755			
5,5	20,6	20,4	11,9	11,8	12,0	11,9	6,95	6,88	1760 ÷ 1765			
7,5	27,1	26,7	15,7	15,4	15,7	15,5	9,08	8,94	1750 ÷ 1755			
11	38,1	37,4	22,0	21,6	22,0	21,5	12,7	12,4	1765 ÷ 1770			
15	53,2	53,4	30,7	30,8	30,4	30,2	17,5	17,4	1770 ÷ 1775			

P _N kW	Efficiency η _N %												IE
	Δ 220 V Y 380 V			Δ 230 V Y 400 V			Δ 380 V Y 660 V			Δ 400 V Y 690 V			
	4/4	3/4	2/4	4/4	3/4	2/4	4/4	3/4	2/4	4/4	3/4	2/4	
0,25	70,0	71,9	67,3	69,9	71,5	67,1	-	-	-	-	-	-	2
0,37	72,0	74,5	68,7	71,9	74,2	68,1	-	-	-	-	-	-	
0,55	81,7	82,1	79,5	82,2	81,8	78,8	-	-	-	-	-	-	
0,75	83,2	82,3	78,4	83,2	82,3	78,4	83,2	82,3	78,4	83,2	82,3	78,4	3
1,1	87,0	86,2	83,2	87,0	86,2	83,2	87,0	86,2	83,2	87,0	86,2	83,2	
1,5	88,0	87,0	84,0	88,0	87,0	84,0	88,0	87,0	84,0	88,0	87,0	84,0	
2,2	89,5	89,4	87,5	89,5	89,4	87,5	89,5	89,4	87,5	89,5	89,4	87,5	
3	90,0	89,5	87,3	90,0	89,5	87,3	90,0	89,5	87,3	90,0	89,5	87,3	
4	90,0	89,9	88,1	90,0	89,9	88,1	90,0	89,9	88,1	90,0	89,9	88,1	
5,5	91,7	91,2	89,4	91,7	91,2	89,4	91,7	91,2	89,4	91,7	91,2	89,4	
7,5	91,7	91,8	90,4	91,7	91,8	90,4	91,7	91,8	90,4	91,7	91,8	90,4	
11	92,7	92,7	91,4	92,7	92,7	91,4	92,7	92,7	91,4	92,7	92,7	91,4	
15	93,3	92,9	91,4	93,3	92,9	91,4	93,3	92,9	91,4	93,3	92,9	91,4	

** Operating conditions to be referred to motor only. About electric pump, refer to limits in user's manual.

sv-ie3-mott-4p60-en_a_te

e-SV SERIES MOTOR NOISE AT 60 Hz

The tables below show the mean sound pressure levels (Lp) measured at 1 meter distance in a free field according to EN ISO 11203. The noise values are measured on 60 Hz motors and have a tolerance of 3 dB (A) according to EN ISO 4871.

MOTORS AT 60 Hz, 2-POLE

POWER kW	MOTOR TYPE IEC SIZE*	NOISE LpA dB
0,37	71R	<70
0,55	71	<70
0,75	80-80R	<70
1,1	80	<70
1,5	90-90R	<70
2,2	90	<70
3	100R	<70
4	112R	<70
5,5	132R	<70
7,5	132	71
11	160R	71
15	160	71
18,5	160	73
22	180R	70
30	200	76
37	200	76
45	225	79
55	250	79

*R = Reduced motor casing size with respect to the standard IEC size

1-125sv_mott_2p60-en_d_tr

MOTORS AT 60 Hz, 4-POLE

POWER kW	MOTOR TYPE IEC SIZE	NOISE LpA dB
0,25	71	<70
0,37	71	<70
0,55	80	<70
0,75	80	<70
1,1	90	<70
1,5	90	<70
2,2	100	<70
3	100	<70
4	112	<70
5,5	132	<70
7,5	132	<70
11	160	<70
15	160	<70

1-125sv_mott-4p60_a_tr

AVAILABLE VOLTAGES SM and PLM MOTORS FOR e-SV SERIES, 2-POLE

P _N kW	SINGLE-PHASE							
	50 Hz				60 Hz			
	1 x 220-240	1 x 100	1 x 110-120	1 x 220-230	1 x 100	1 x 110-115	1 x 120-127	1 x 200-210
0,37	s	o	o	s	-	o	-	-
0,55	s	o	o	s	o	o	o	o
0,75	s	o	o	s	o	o	o	o
1,1	s	-	o	s	-	o	-	o
1,5	s	-	-	s	-	o	-	o
2,2	s	-	-	s	-	-	-	-

P _N kW	THREE-PHASE																			
	50 Hz									60 Hz									50/60 Hz	
	3 x 220-230-240/380-400-415	3 x 380-400-415/660-690	3 x 200-208/346-360	3 x 255-265/440-460	3 x 290-300/500-525	3 x 440-460/-	3 x 500-525/-	3 x 220-230/380-400	3 x 255-265-277/440-460-480	3 x 380-400/660-690	3 x 440-460-480/-	3 x 110-115/190-200	3 x 200-208/346-360	3 x 330-346/575-600	3 x 575/-	3 x 230/400 50 Hz	3 x 265/460 60 Hz	3 x 400/690 50 Hz	3 x 460/- 60 Hz	
0,37	s	o	o	o	o	o	o	o	s	o	o	o	o	o	o	o	o	o	o	
0,55	s	o	o	o	o	o	o	o	s	o	o	o	o	o	o	o	o	o	o	
0,75	s	o	o	o	o	o	o	o	s	o	o	o	o	o	o	o	o	o	o	
1,1	s	o	o	o	o	o	o	o	s	o	o	o	o	o	o	o	o	o	o	
1,5	s	o	o	o	o	o	o	o	s	o	o	o	o	o	o	o	o	o	o	
2,2	s	o	o	o	o	o	o	o	s	o	o	o	o	o	o	o	o	o	o	
3	s	o	o	o	o	o	o	o	s	o	o	o	o	o	o	o	o	o	o	
4	o	s	o	o	o	o	o	o	s	o	o	o	o	o	o	o	o	o	o	
5,5	o	s	o	o	o	o	o	o	s	o	o	o	o	o	o	o	o	o	o	
7,5	o	s	o	o	o	o	o	o	s	o	o	o	o	o	o	o	o	o	o	
11	o	s	o	o	o	o	o	o	s	o	o	o	o	o	o	o	o	o	o	
15	o	s	o	o	o	o	o	o	s	o	o	o	o	o	o	o	o	o	o	
18,5	o	s	o	o	o	o	o	o	s	o	o	o	o	o	o	o	o	o	o	
22	o	s	o	o	o	o	o	o	s	o	o	o	o	o	o	o	o	o	o	

s = Standard voltage o = voltage upon request - = Not available

sv-volt-low-a-en_b_te

For higher power motors special voltages available on request.

Tolerances on nominal voltages

• **50 Hz:**

- ± 10% on the single voltage value shown on the rating plate.
- ± 5% on voltage range shown on the rating plate.

• **60 Hz:**

- ± 10% on the voltage values shown on the rating plate.

REPORTS AND DECLARATIONS

REPORTS AND DECLARATIONS

i) Test reports

- a) **Factory Test Report** (Lowara identity code: 1A)
(not available for all pump types; contact Customer Service in advance)
- Test report compiled at the end of the assembly line, including flow-head performance test (ISO 9906:2012 – Grade 3B) and tightness test.
- b) **Audit Test Report** (Lowara identity code: 1B)
- Test report for electric pumps compiled in the test room, comprising flow-head-pump input-pump efficiency performance test (ISO 9906:2012 – Grade 3B)
- c) **NPSH Test Report** (Lowara identity code: 1B / CTF-NP)
(unavailable for submerged or submergible pumps)
- Test report for electric pumps compiled in the test room, comprising flow-NPSH performance test (ISO 9906:2012 – Grade 3B)
- d) **Noise Test Report** (Lowara identity code: 1B / CTF-RM)
(unavailable for submerged pumps)
- Report indicating sound pressure and power measurements (EN ISO 20361, EN ISO 11203, EN ISO 4871) using the
• intensimetric (EN ISO 9614-1, EN ISO 9614-2), or
• phonometric method.
- e) **Vibration Test Report**
(unavailable for submerged or submergible pumps)
- Report indicating vibration measurements (ISO 10816-1)

ii) Declaration of product conformity with the technical requirements indicated in the order

- a) **EN 10204:2004 - type 2.1** (Lowara identity code: CTF-21)
- does not include test results on supplied or similar products.
- b) **EN 10204:2004 - type 2.2** (Lowara identity code: CTF-22)
- includes test results (materials certificates) on similar products.

iii) Issue of a further EC Declaration of Conformity,

- in addition to the one accompanying the product, it comprises references to European law and the main technical standards (e.g.: MD 2006/42/EC, EMCD 2014/30/EU, ErP 2009/125/EC).

N.B.: if the request is made after receipt of the product, communicate the code (name) and serial number (date + progressive number).

iv) Manufacturer's declaration of conformity

- relative to one of more types of products without indicating specific codes and serial numbers.

v) Other certificates and/or documentation on request

- subject to availability or feasibility.

vi) Duplication of certificates and/or documentation on request

- subject to availability or feasibility.

ACCESSORIES

THREADED COUNTERFLANGES KIT (SV F, N, R, G) EN 1092-1

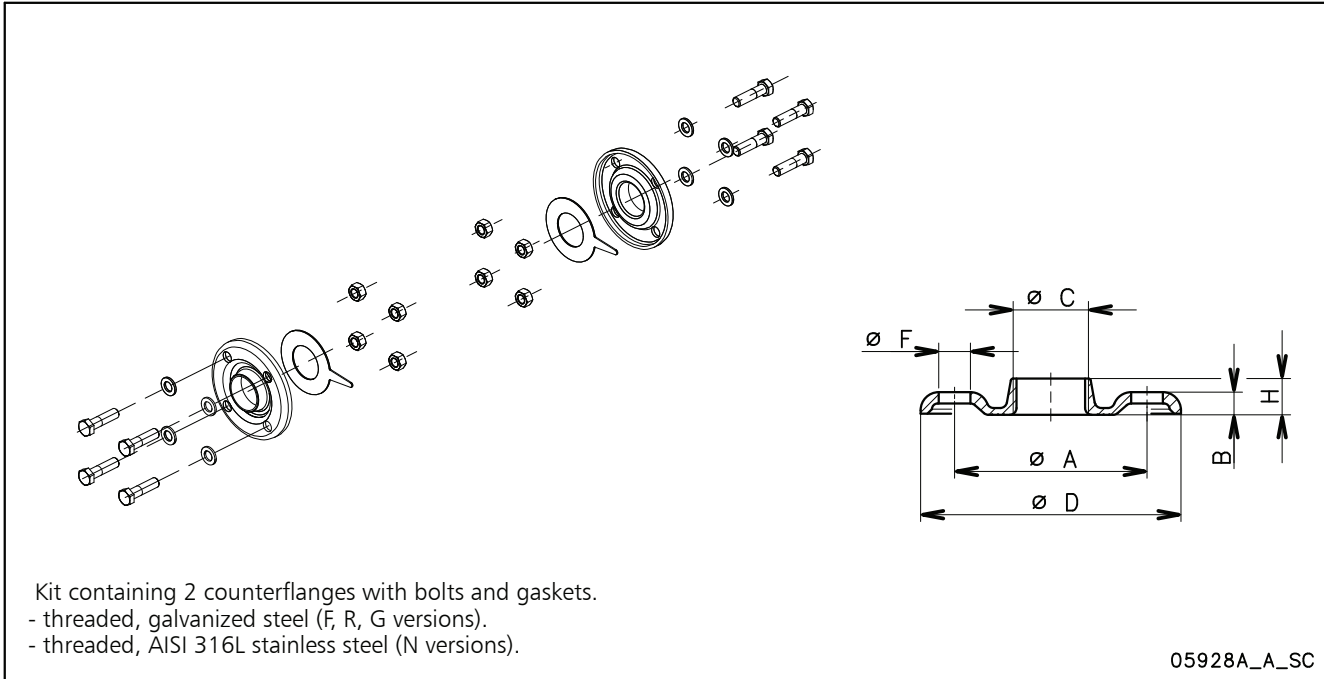

P.NUMBER	DESCRIPTION	PUMP TYPE	DN	ø C	DIMENSIONS (mm)				HOLES		**	PN
					ø A	B	ø D	H	ø F	N°		
109398000	KIT RP1" PN25 GALVANIZED STEEL	1-3SV	25	Rp 1	85	10	115	16	14	4	50	25
109398002	KIT RP1" PN25 AISI 316	1-3SV	25	Rp 1	85	10	115	16	14	4	50	25
109398010	KIT RP1"1/4 PN25 GALVANIZED STEEL	5SV	32	Rp 1 1/4	100	13	140	16	18	4	100	25
109398012	KIT RP1"1/4 PN25 AISI 316	5SV	32	Rp 1 1/4	100	13	140	16	18	4	100	25
109398020	KIT RP1"1/2 PN25 GALVANIZED STEEL	10SV	40	Rp 1 1/2	110	14	150	19	18	4	100	25
109398022	KIT RP1"1/2 PN25 AISI 316	10SV	40	Rp 1 1/2	110	14	150	19	18	4	100	25
109398030	KIT RP2" PN25 GALVANIZED STEEL	15-22SV	50	Rp 2	125	16	165	24	18	4	100	25
109398032	KIT RP2" PN25 AISI 316	15-22SV	50	Rp 2	125	16	165	24	18	4	100	25
109392710	KIT RP2"1/2 PN16 GALVANIZED STEEL	33SV	65	Rp 2 1/2	145	16	185	23	18	4	100	16
109392750	KIT RP2"1/2 PN16 AISI 316	33SV	65	Rp 2 1/2	145	16	185	23	18	4	100	16
109392720	KIT RP3" PN16 GALVANIZED STEEL	46SV	80	Rp 3	160	17	200	27	18	8	100	16
109392760	KIT RP3" PN16 AISI 316	46SV	80	Rp 3	160	17	200	27	18	8	100	16
109392730	KIT RP4" PN16 GALVANIZED STEEL	66SV-92SV	100	Rp 4	180	18	220	31	18	8	100	16
109392770	KIT RP4" PN16 AISI 316	66SV-92SV	100	Rp 4	180	18	220	31	18	8	100	16

** Tightening torque (Nm)

kit_flg_fil-en_b_td

WELD-ON ROUND COUNTERFLANGES KIT (SV G, N) EN 1092-1

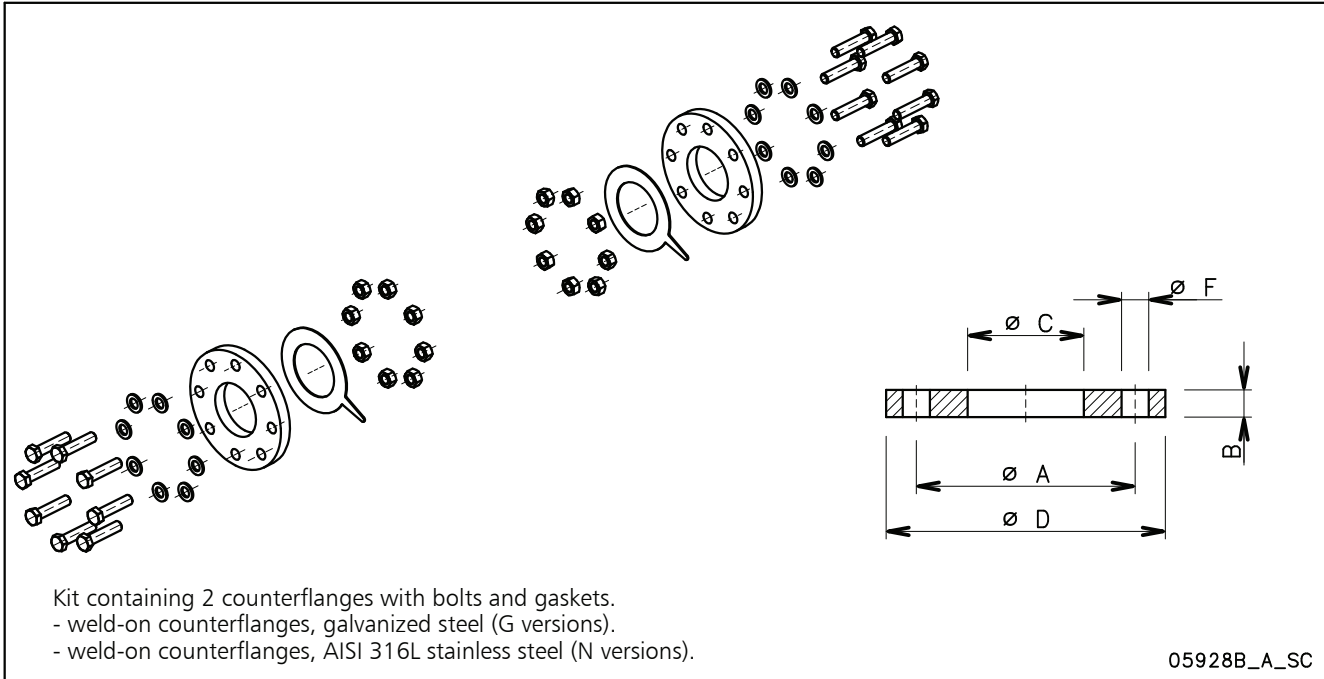

P. NUMBER	DESCRIPTION	PUMP TYPE	DN	ø C	DIMENSIONS (mm)			HOLES		**	PN
					ø A	B	ø D	ø F	N°		
109392800	KIT DN65 PN16 GALVANIZED STEEL	33SV	65	77	145	18	185	18	4	100	16
109392880	KIT DN65 PN16 AISI 316	33SV	65	77	145	18	185	18	4	100	16
109392840	KIT DN65 PN25-40 GALVANIZED STEEL	33SV	65	77	145	18	185	18	8	200	25-40
109392920	KIT DN65 PN25-40 AISI 316	33SV	65	77	145	18	185	18	8	200	25-40
109392810	KIT DN80 PN16 GALVANIZED STEEL	46SV	80	90	160	20	200	18	8	100	16
109392890	KIT DN80 PN16 AISI 316	46SV	80	90	160	20	200	18	8	100	16
109392850	KIT DN80 PN25-40 GALVANIZED STEEL	46SV	80	90	160	20	200	18	8	200	25-40
109392930	KIT DN80 PN25-40 AISI 316	46SV	80	90	160	20	200	18	8	200	25-40
109392820	KIT DN100 PN16 GALVANIZED STEEL	66-92SV	100	115,5	180	22	220	18	8	100	16
109392900	KIT DN100 PN16 AISI 316	66-92SV	100	115,5	180	22	220	18	8	100	16
109392860	KIT DN100 PN25-40 GALVANIZED STEEL	66-92SV	100	115,5	180	22	220	22	8	200	25-40
109392940	KIT DN100 PN25-40 AISI 316	66-92SV	100	115,5	180	22	220	22	8	200	25-40
109398080	KIT DN125 PN16 GALVANIZED STEEL	125SV	125	141	210	24	250	18	8	100	16
109398082	KIT DN125 PN16 AISI 316	125SV	125	141	210	24	250	18	8	100	16
109398090	KIT DN125 PN25-40 GALVANIZED STEEL	125SV	125	141	220	28	270	26	8	200	25-40
109398092	KIT DN125 PN25-40 AISI 316	125SV	125	141	220	28	270	26	8	200	25-40

** Tightening torque (Nm)

kit_flg_sald-en_b_td

VICTAULIC COUPLINGS KIT (SV V)
MAXIMUM OPERATING PRESSURE 6900 kPa

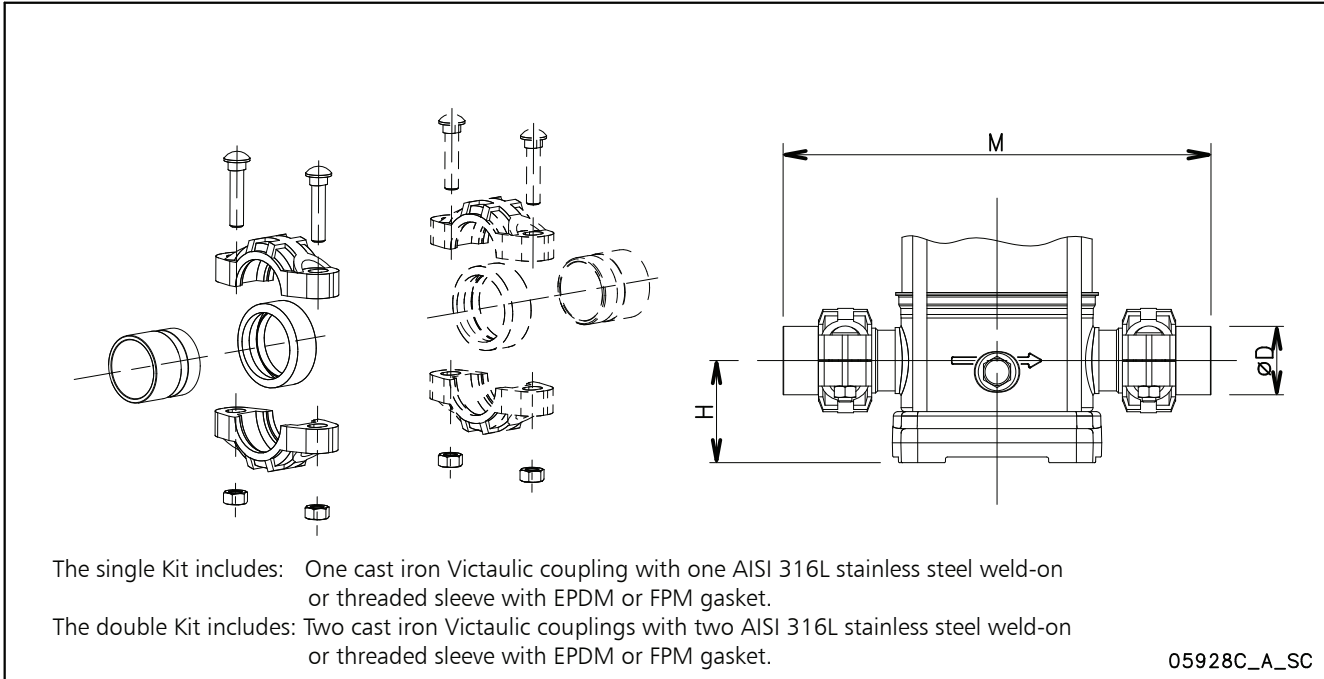

P.NUMBER	DESCRIPTION	PUMP TYPE	DIMENSIONS (mm)			
			DN	ø D	M	H
109390880	KIT SINGLE VICTAULIC THREADED R 1"1/4 EPDM	1-3-5SV V	DN32	R 1"1/4	320	75
109390980	KIT SINGLE VICTAULIC THREADED R 1"1/4 FPM	1-3-5SV V	DN32	R 1"1/4	320	75
109390890	KIT SINGLE VICTAULIC THREADED R 2" EPDM	10-15-22SV V	DN50	R 2"	378	90
109390990	KIT SINGLE VICTAULIC THREADED R 2" FPM	10-15-22SV V	DN50	R 2"	378	90
109390860	KIT SINGLE VICTAULIC DN32 WELD-ON EPDM	1-3-5SV V	DN32	42,2	320	75
109390960	KIT SINGLE VICTAULIC DN32 WELD-ON FPM	1-3-5SV V	DN32	42,2	320	75
109390870	KIT SINGLE VICTAULIC DN50 WELD-ON EPDM	10-15-22SV V	DN50	60,3	378	90
109390970	KIT SINGLE VICTAULIC DN50 WELD-ON FPM	10-15-22SV V	DN50	60,3	378	90
109398400	KIT DOUBLE VICTAULIC THREADED R 1"1/4 EPDM	1-3-5SV V	DN32	R 1"1/4	320	75
109398401	KIT DOUBLE VICTAULIC THREADED R 1"1/4 FPM	1-3-5SV V	DN32	R 1"1/4	320	75
109398410	KIT DOUBLE VICTAULIC THREADED R 2" EPDM	10-15-22SV V	DN50	R 2"	378	90
109398411	KIT DOUBLE VICTAULIC THREADED R 2" FPM	10-15-22SV V	DN50	R 2"	378	90
109398420	KIT DOUBLE VICTAULIC DN32 WELD-ON EPDM	1-3-5SV V	DN32	42,2	320	75
109398421	KIT DOUBLE VICTAULIC DN32 WELD-ON FPM	1-3-5SV V	DN32	42,2	320	75
109398430	KIT DOUBLE VICTAULIC DN50 WELD-ON EPDM	10-15-22SV V	DN50	60,3	378	90
109398431	KIT DOUBLE VICTAULIC DN50 WELD-ON FPM	10-15-22SV V	DN50	60,3	378	90

1-22sv-giunti-vict-en_b_td

VICTAULIC COUPLINGS TANDEM KIT (SV P)
MAXIMUM OPERATING PRESSURE 6900 kPa

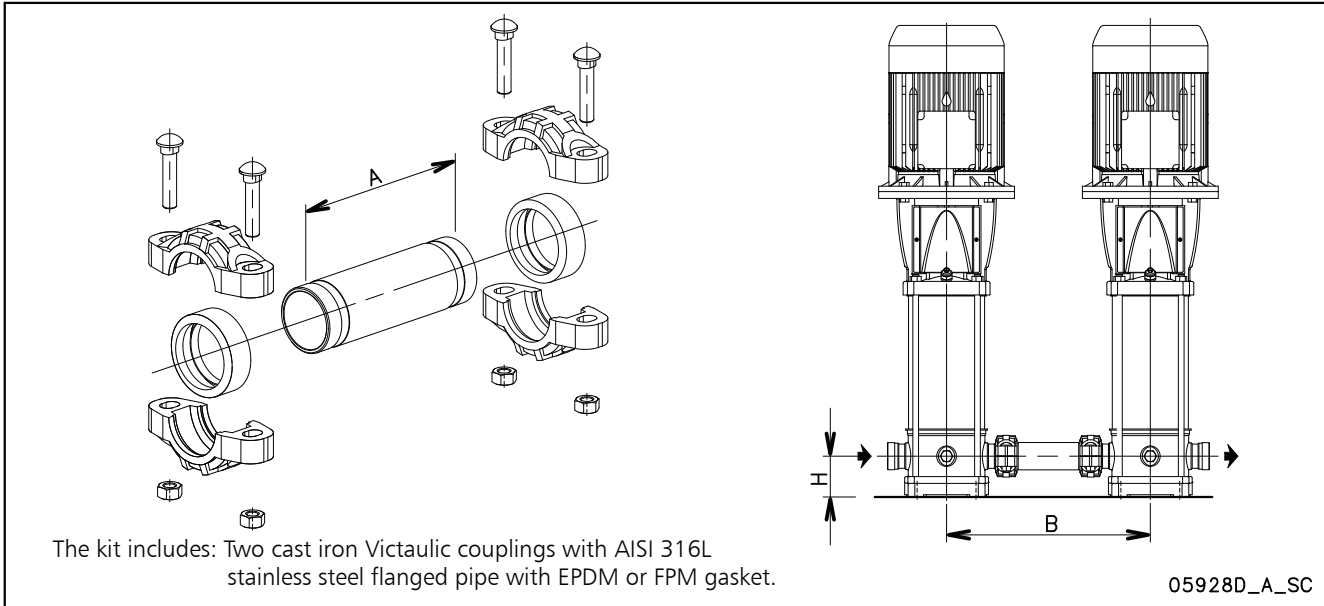

P.NUMBER	DESCRIPTION	PUMP TYPE	DIMENSIONS (mm)			
			DN	A	B	H
109398250	KIT TANDEM VICTAULIC DN32 EPDM	1-3-5SV V	DN32	134	350	75
109398251	KIT TANDEM VICTAULIC DN32 FPM	1-3-5SV V	DN32	134	350	75
109398260	KIT TANDEM VICTAULIC DN50 EPDM	10-15-22SV V	DN50	183	450	90
109398261	KIT TANDEM VICTAULIC DN50 FPM	10-15-22SV V	DN50	183	450	90

kit_tandem_vict-en_b_td

ROUND COUNTERFLANGES TANDEM KIT (SV P)
MAXIMUM OPERATING PRESSURE 4500 kPa

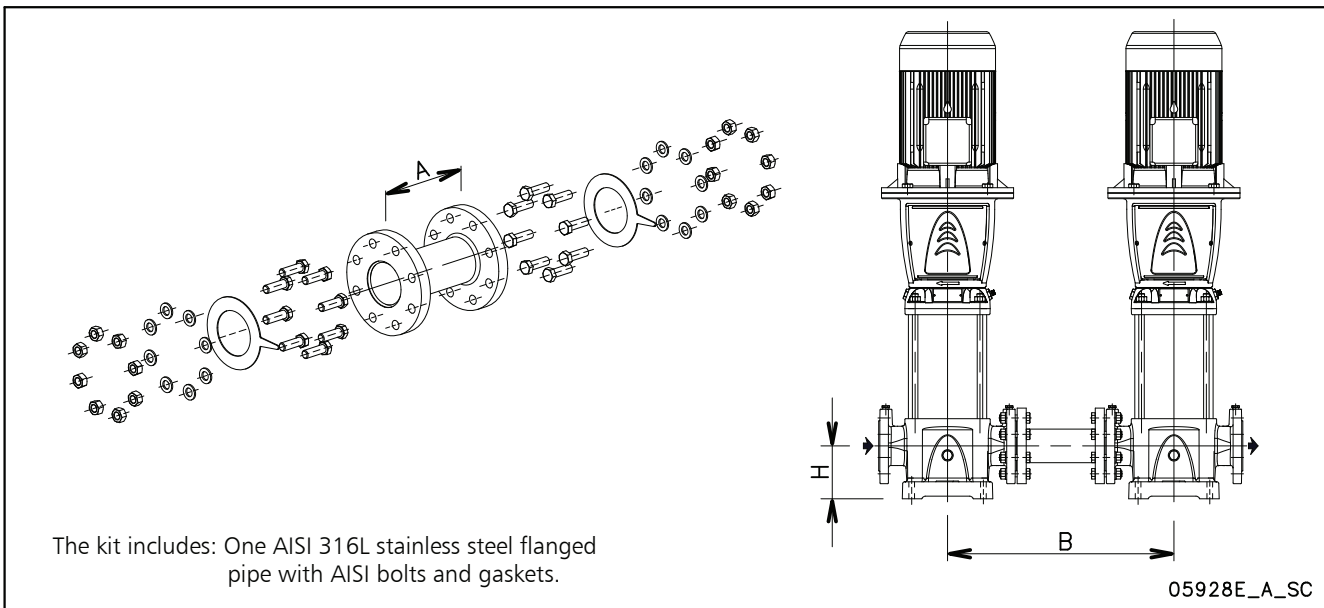

P.NUMBER	DESCRIPTION	PUMP TYPE	DIMENSIONS (mm)			
			DN	A	B	H
109398300	KIT TANDEM ROUND FLANGE DN65	33SV	DN65	176	500	105
109398310	KIT TANDEM ROUND FLANGE DN80	46SV	DN80	231	600	140
109398320	KIT TANDEM ROUND FLANGE DN100	66-92SV	DN100	281	650	140
109398330	KIT TANDEM ROUND FLANGE DN125	125SV	DN125	316	800	160

kit_tandem_round_flg-en_b_td

THREADED CLAMP KIT

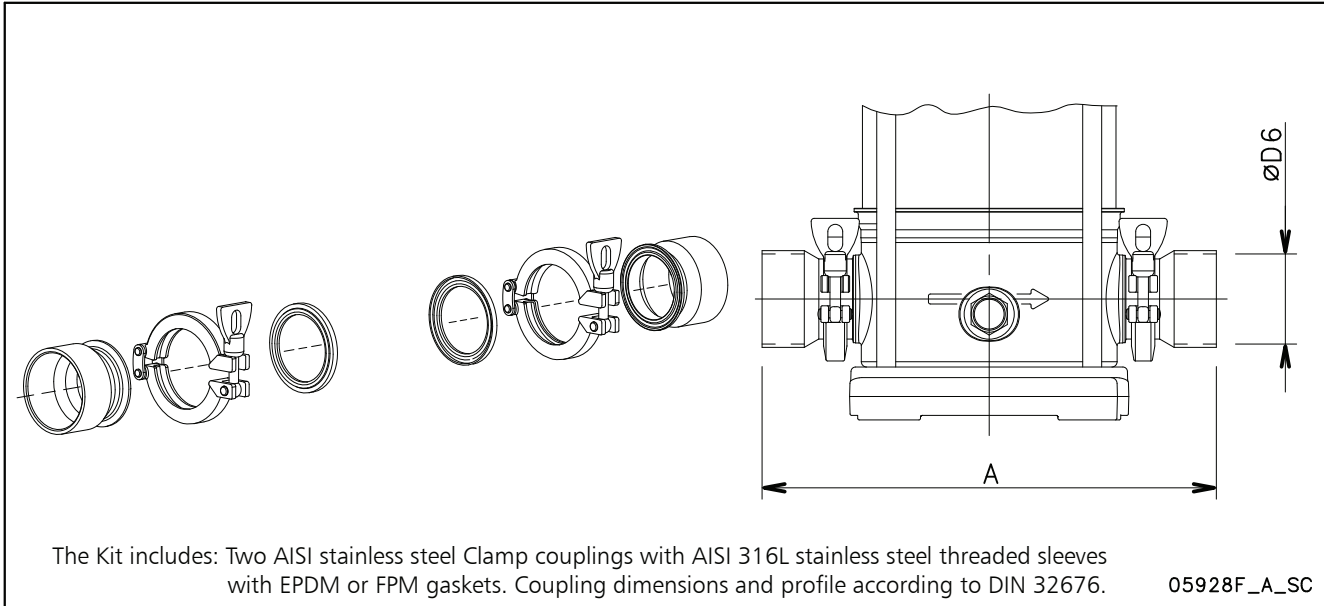

P.NUMBER	DESCRIPTION	PUMP TYPE	DIMENSIONS (mm)		
			DN	A	ø D6
109391860	KIT CLAMP DN32 THREADED RP 1"1/4 EPDM	1-3-5SV C	DN32	245	Rp 1 1/4
109391870	KIT CLAMP DN32 THREADED RP 1"1/4 FPM	1-3-5SV C	DN32	245	Rp 1 1/4
109391900	KIT CLAMP DN50 THREADED RP 2" EPDM	10-15-22SV C	DN50	301	Rp 2
109391910	KIT CLAMP DN50 THREADED RP 2" FPM	10-15-22SV C	DN50	301	Rp 2

kit-clamp_fill-en_a_td

WELD-ON CLAMP KIT

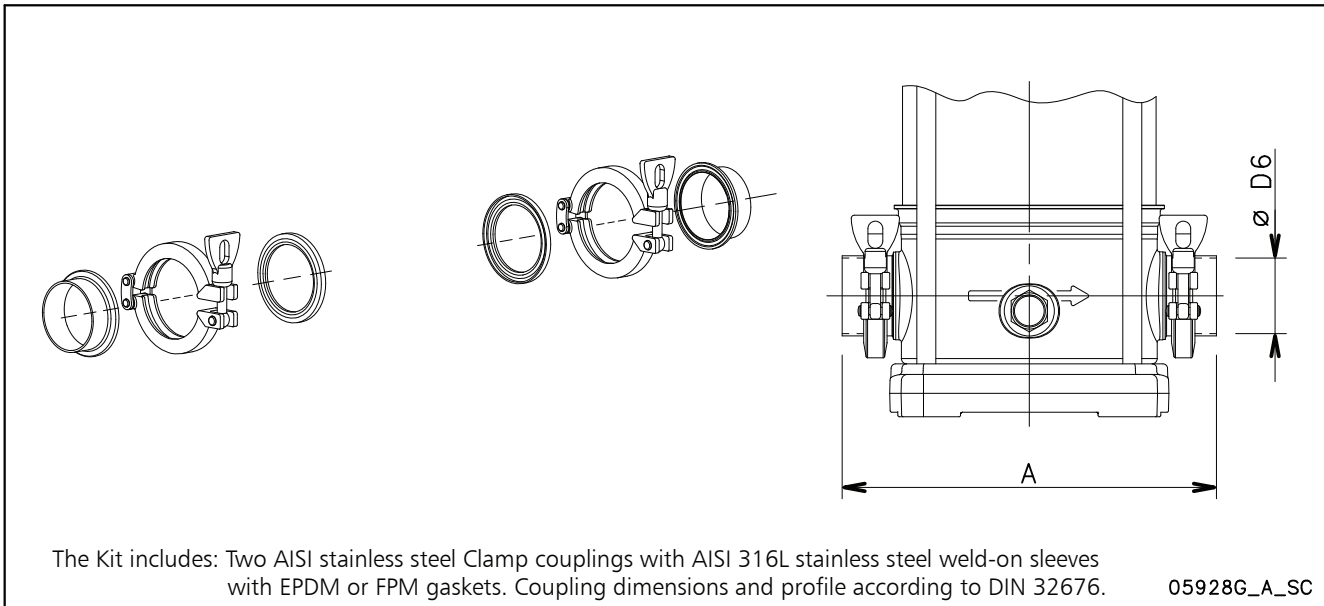

P.NUMBER	DESCRIPTION	PUMP TYPE	DIMENSIONS (mm)		
			DN	A	ø D6
109391880	KIT CLAMP DN32 WELD-ON EPDM	1-3-5SV C	DN32	245	35
109391890	KIT CLAMP DN32 WELD-ON FPM	1-3-5SV C	DN32	245	35
109391920	KIT CLAMP DN50 WELD-ON EPDM	10-15-22SV C	DN50	301	53
109391930	KIT CLAMP DN50 WELD-ON FPM	10-15-22SV C	DN50	301	53

kit-clamp_sald-en_a_td

HORIZONTAL INSTALLATION BRACKET KIT (SV)

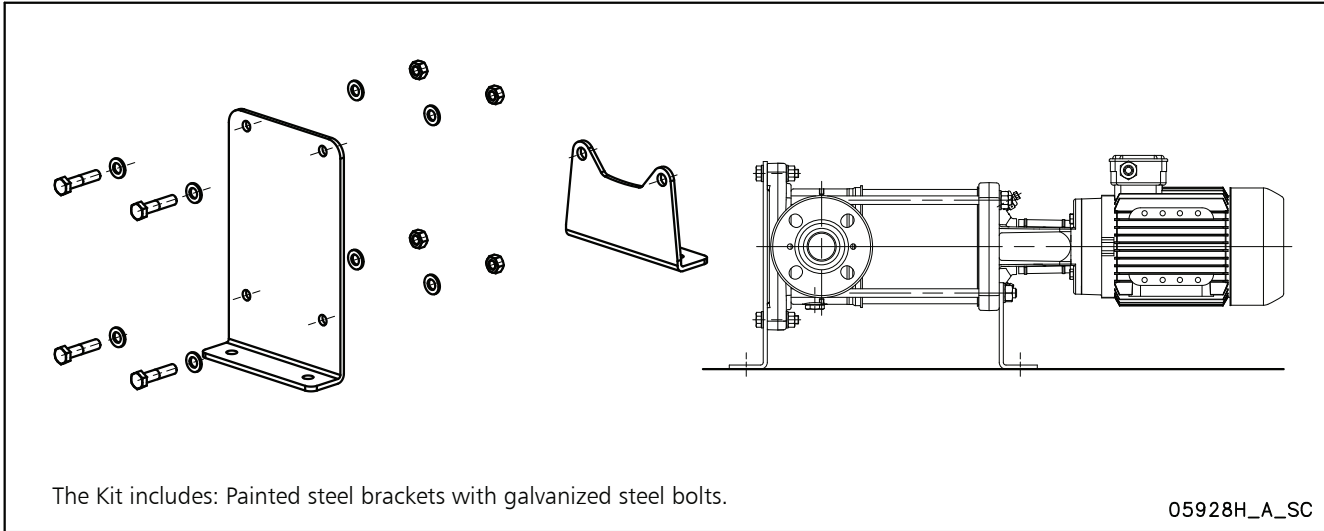

P.NUMBER	DESCRIPTION	MOTOR TYPE
148996700	BRACKET KIT 1-3-5SV F-N	LOWARA
148996710	BRACKET KIT 10-15-22SV F-N (0,75 ÷ 11 kW)	
148990700	BRACKET KIT 33SV G-N (1,1 ÷ 11 kW)	
148990760	BRACKET KIT 46SV G-N (1,1 ÷ 11 kW)	
148990770	BRACKET KIT 66-92SV G-N (1,1 ÷ 11 kW)	
148996800	BRACKET KIT 125SV G-N (7,5 kW)	

148996700-en_b_td

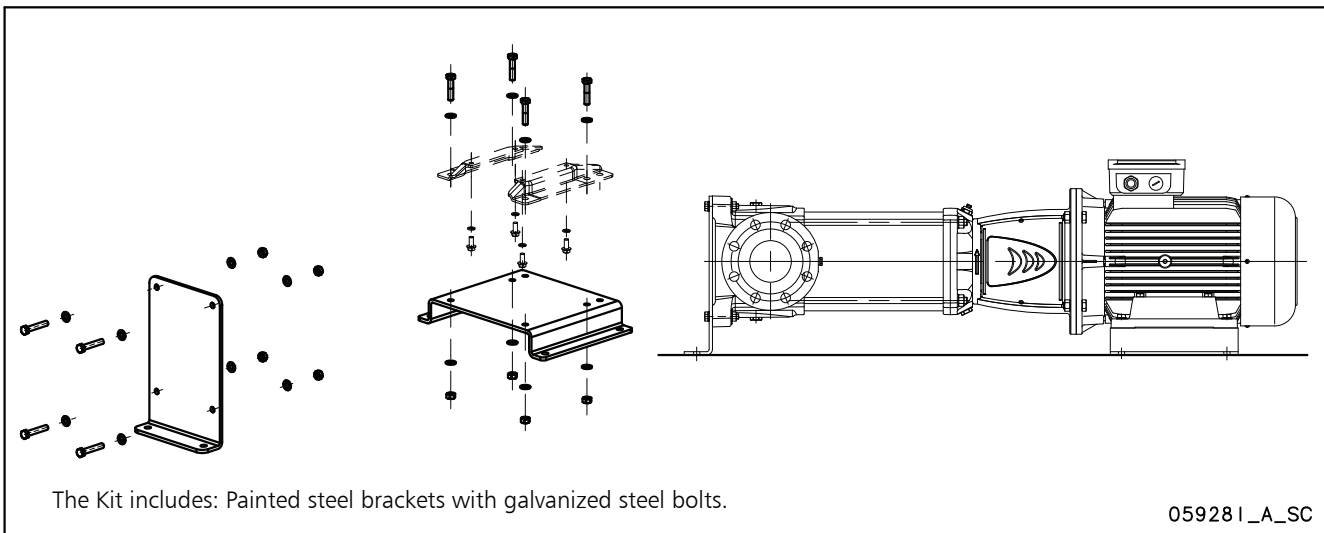

PART NUMBER	DESCRIPTION	DIMENSIONS (mm)
148990920	BRACKET KIT 33SV G-N (15 ÷ 22 kW)	LOWARA
148990730	BRACKET KIT 33SV G-N (22 kW)	STANDARD B35 SIZE 180 (22kW)
148990930	BRACKET KIT 46-66-92SV G-N (15 ÷ 22 kW)	LOWARA
148990800	BRACKET KIT 46-66-92SV G-N (22 kW)	STANDARD B35 SIZE 180 (22kW)
148996810	BRACKET KIT 125SV G-N (15 ÷ 22 kW)	LOWARA
148996850	BRACKET KIT 125SV G-N (22 kW)	STANDARD B35 SIZE 180 (22kW)
148996820	BRACKET KIT 125SV G-N (30 ÷ 37 kW)	* WEG B35 SIZE 200, OMEGA B35 SIZE 200
148996830	BRACKET KIT 125SV G-N (45 kW)	* WEG B35 SIZE 225, OMEGA B35 SIZE 225

* for these models change the motor from V1/B5 to B35 construction design.

148990920-en_c_td

HORIZONTAL INSTALLATION BRACKET KIT (SV)

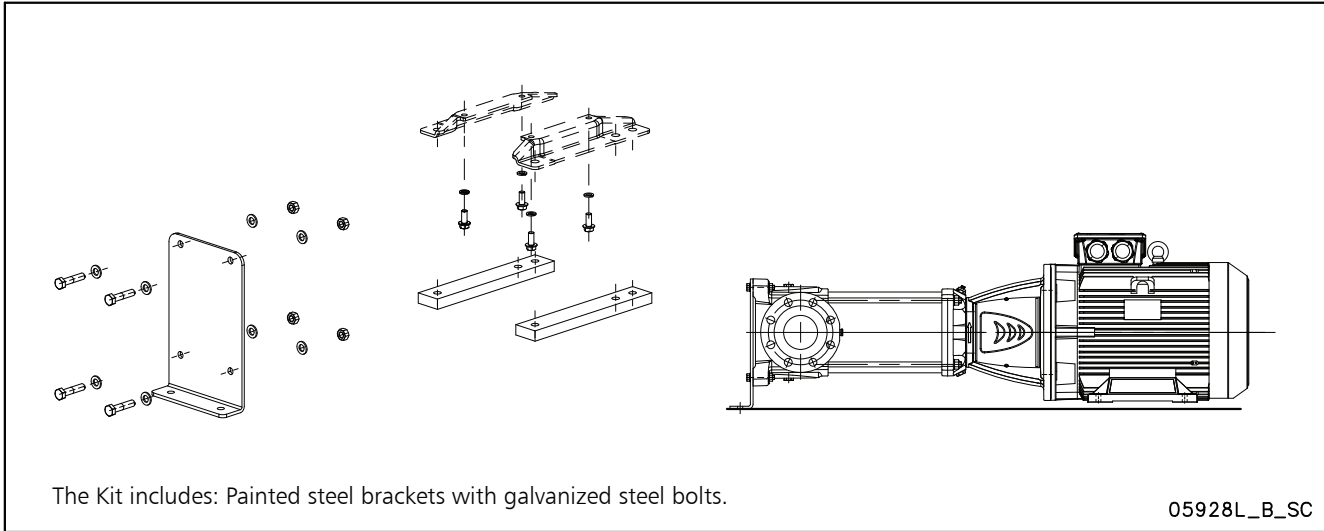

PART NUMBER	DESCRIPTION	DIMENSIONS (mm)
148996720	BRACKET KIT 15-22SV F-N (15 ÷ 18,5 kW)	LOWARA
148996750	BRACKET KIT 33SV G-N (30 ÷ 37 kW)	* WEG B35 SIZE 200, OMEGA B35 SIZE 200
148996760	BRACKET KIT 46-66-92SV G-N (30 ÷ 37 kW)	* WEG B35 SIZE 200, OMEGA B35 SIZE 200
148996770	BRACKET KIT 46-66-92SV G-N (45 kW)	* WEG B35 SIZE 225, OMEGA B35 SIZE 225
148996840	BRACKET KIT 125SV G-N (55 kW)	* WEG B35 SIZE 250, OMEGA B35 SIZE 250

* for these models change the motor from V1/B5 to B35 construction design.

148996720-en_c_td

PROTECTION SENSOR AGAINST DRY RUNNING KIT (SV)

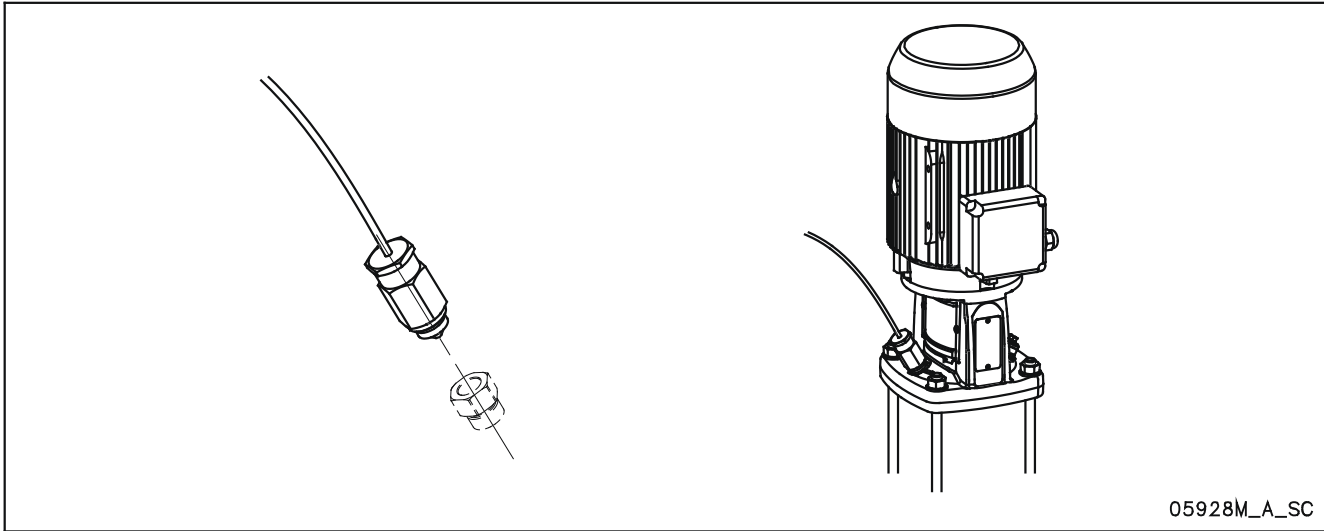

P.NUMBER	DESCRIPTION	NOTE	PUMP TYPE
109394600	KIT SENSOR DRP-HV	POWER SUPPLY 15V DC FOR HYDROVAR	1-125 SV
109394610	KIT SENSOR DRP-GP	POWER SUPPLY 24V AC FOR GENERAL USE	1-125 SV

kit_sensor-en_a_td

TECHNICAL APPENDIX

NPSH

The minimum operating values that can be reached at the pump suction end are limited by the onset of cavitation.

Cavitation is the formation of vapour-filled cavities within liquids where the pressure is locally reduced to a critical value, or where the local pressure is equal to, or just below the vapour pressure of the liquid.

The vapour-filled cavities flow with the current and when they reach a higher pressure area the vapour contained in the cavities condenses. The cavities collide, generating pressure waves that are transmitted to the walls. These, being subjected to stress cycles, gradually become deformed and yield due to fatigue. This phenomenon, characterized by a metallic noise produced by the hammering on the pipe walls, is called incipient cavitation.

The damage caused by cavitation may be magnified by electrochemical corrosion and a local rise in temperature due to the plastic deformation of the walls. The materials that offer the highest resistance to heat and corrosion are alloy steels, especially austenitic steel. The conditions that trigger cavitation may be assessed by calculating the total net suction head, referred to in technical literature with the acronym NPSH (Net Positive Suction Head).

The NPSH represents the total energy (expressed in m.) of the liquid measured at suction under conditions of incipient cavitation, excluding the vapour pressure (expressed in m.) that the liquid has at the pump inlet.

To find the static height h_z at which to install the machine under safe conditions, the following formula must be verified:

$$h_p + h_z \geq (\text{NPSHr} + 0.5) + h_f + h_{pv} \quad \textcircled{1}$$

where:

h_p is the absolute pressure applied to the free liquid surface in the suction tank, expressed in m. of liquid; h_p is the quotient between the barometric pressure and the specific weight of the liquid.

h_z is the suction lift between the pump axis and the free liquid surface in the suction tank, expressed in m.; h_z is negative when the liquid level is lower than the pump axis.

h_f is the flow resistance in the suction line and its accessories, such as: fittings, foot valve, gate valve, elbows, etc.

h_{pv} is the vapour pressure of the liquid at the operating temperature, expressed in m. of liquid. h_{pv} is the quotient between the P_v vapour pressure and the liquid's specific weight.

0,5 is the safety factor.

The maximum possible suction head for installation depends on the value of the atmospheric pressure (i.e. the elevation above sea level at which the pump is installed) and the temperature of the liquid.

To help the user, with reference to water temperature (4° C) and to the elevation above sea level, the following tables show the drop in hydraulic pressure head in relation to the elevation above sea level, and the suction loss in relation to temperature.

Water temperature (°C)	20	40	60	80	90	110	120
Suction loss (m)	0,2	0,7	2,0	5,0	7,4	15,4	21,5

Elevation above sea level (m)	500	1000	1500	2000	2500	3000
Suction loss (m)	0,55	1,1	1,65	2,2	2,75	3,3

Friction loss is shown in the tables "Flow resistance" of this catalogue. To reduce it to a minimum, especially in cases of high suction head (over 4-5 m.) or within the operating limits with high flow rates, we recommend using a suction line having a larger diameter than that of the pump's suction port. It is always a good idea to position the pump as close as possible to the liquid to be pumped.

Make the following calculation:

Liquid: water at ~15°C $\gamma = 1 \text{ kg/dm}^3$

Flow rate required: 25 m³/h

Head for required delivery: 70 m.

Suction lift: 3,5 m.

The selection is an 33SVG075T pump whose NPSH required value is 2 m at 25 m³/h.

For water at 15 °C

$$h_p = P_a / \gamma = 10,33\text{m}, h_{pv} = P_v / \gamma = 0,174\text{m} (0,01701 \text{ bar})$$

The H_f flow resistance in the suction line with foot valves is ~1,2 m.

By substituting the parameters in formula $\textcircled{1}$ with the numeric values above, we have:

$$10,33 + (-3,5) \geq (2 + 0,5) + 1,2 + 0,17$$

from which we have: 6,8 > 3,9

The relation is therefore verified.

VAPOUR PRESSURE

VAPOUR PRESSURE p_s AND ρ DENSITY OF WATER TABLE

t °C	T K	p_s bar	ρ kg/dm ³	t °C	T K	p_s bar	ρ kg/dm ³	t °C	T K	p_s bar	ρ kg/dm ³
0	273,15	0,00611	0,9998	55	328,15	0,15741	0,9857	120	393,15	1,9854	0,9429
1	274,15	0,00657	0,9999	56	329,15	0,16511	0,9852	122	395,15	2,1145	0,9412
2	275,15	0,00706	0,9999	57	330,15	0,17313	0,9846	124	397,15	2,2504	0,9396
3	276,15	0,00758	0,9999	58	331,15	0,18147	0,9842	126	399,15	2,3933	0,9379
4	277,15	0,00813	1,0000	59	332,15	0,19016	0,9837	128	401,15	2,5435	0,9362
5	278,15	0,00872	1,0000	60	333,15	0,1992	0,9832	130	403,15	2,7013	0,9346
6	279,15	0,00935	1,0000	61	334,15	0,2086	0,9826	132	405,15	2,867	0,9328
7	280,15	0,01001	0,9999	62	335,15	0,2184	0,9821	134	407,15	3,041	0,9311
8	281,15	0,01072	0,9999	63	336,15	0,2286	0,9816	136	409,15	3,223	0,9294
9	282,15	0,01147	0,9998	64	337,15	0,2391	0,9811	138	411,15	3,414	0,9276
10	283,15	0,01227	0,9997	65	338,15	0,2501	0,9805	140	413,15	3,614	0,9258
11	284,15	0,01312	0,9997	66	339,15	0,2615	0,9799	145	418,15	4,155	0,9214
12	285,15	0,01401	0,9996	67	340,15	0,2733	0,9793	155	428,15	5,433	0,9121
13	286,15	0,01497	0,9994	68	341,15	0,2856	0,9788	160	433,15	6,181	0,9073
14	287,15	0,01597	0,9993	69	342,15	0,2984	0,9782	165	438,15	7,008	0,9024
15	288,15	0,01704	0,9992	70	343,15	0,3116	0,9777	170	443,15	7,920	0,8973
16	289,15	0,01817	0,9990	71	344,15	0,3253	0,9770	175	448,15	8,924	0,8921
17	290,15	0,01936	0,9988	72	345,15	0,3396	0,9765	180	453,15	10,027	0,8869
18	291,15	0,02062	0,9987	73	346,15	0,3543	0,9760	185	458,15	11,233	0,8815
19	292,15	0,02196	0,9985	74	347,15	0,3696	0,9753	190	463,15	12,551	0,8760
20	293,15	0,02337	0,9983	75	348,15	0,3855	0,9748	195	468,15	13,987	0,8704
21	294,15	0,24850	0,9981	76	349,15	0,4019	0,9741	200	473,15	15,550	0,8647
22	295,15	0,02642	0,9978	77	350,15	0,4189	0,9735	205	478,15	17,243	0,8588
23	296,15	0,02808	0,9976	78	351,15	0,4365	0,9729	210	483,15	19,077	0,8528
24	297,15	0,02982	0,9974	79	352,15	0,4547	0,9723	215	488,15	21,060	0,8467
25	298,15	0,03166	0,9971	80	353,15	0,4736	0,9716	220	493,15	23,198	0,8403
26	299,15	0,03360	0,9968	81	354,15	0,4931	0,9710	225	498,15	25,501	0,8339
27	300,15	0,03564	0,9966	82	355,15	0,5133	0,9704	230	503,15	27,976	0,8273
28	301,15	0,03778	0,9963	83	356,15	0,5342	0,9697	235	508,15	30,632	0,8205
29	302,15	0,04004	0,9960	84	357,15	0,5557	0,9691	240	513,15	33,478	0,8136
30	303,15	0,04241	0,9957	85	358,15	0,5780	0,9684	245	518,15	36,523	0,8065
31	304,15	0,04491	0,9954	86	359,15	0,6011	0,9678	250	523,15	39,776	0,7992
32	305,15	0,04753	0,9951	87	360,15	0,6249	0,9671	255	528,15	43,246	0,7916
33	306,15	0,05029	0,9947	88	361,15	0,6495	0,9665	260	533,15	46,943	0,7839
34	307,15	0,05318	0,9944	89	362,15	0,6749	0,9658	265	538,15	50,877	0,7759
35	308,15	0,05622	0,9940	90	363,15	0,7011	0,9652	270	543,15	55,058	0,7678
36	309,15	0,05940	0,9937	91	364,15	0,7281	0,9644	275	548,15	59,496	0,7593
37	310,15	0,06274	0,9933	92	365,15	0,7561	0,9638	280	553,15	64,202	0,7505
38	311,15	0,06624	0,9930	93	366,15	0,7849	0,9630	285	558,15	69,186	0,7415
39	312,15	0,06991	0,9927	94	367,15	0,8146	0,9624	290	563,15	74,461	0,7321
40	313,15	0,07375	0,9923	95	368,15	0,8453	0,9616	295	568,15	80,037	0,7223
41	314,15	0,07777	0,9919	96	369,15	0,8769	0,9610	300	573,15	85,927	0,7122
42	315,15	0,08198	0,9915	97	370,15	0,9094	0,9602	305	578,15	92,144	0,7017
43	316,15	0,09639	0,9911	98	371,15	0,9430	0,9596	310	583,15	98,70	0,6906
44	317,15	0,09100	0,9907	99	372,15	0,9776	0,9586	315	588,15	105,61	0,6791
45	318,15	0,09582	0,9902	100	373,15	1,0133	0,9581	320	593,15	112,89	0,6669
46	319,15	0,10086	0,9898	102	375,15	1,0878	0,9567	325	598,15	120,56	0,6541
47	320,15	0,10612	0,9894	104	377,15	1,1668	0,9552	330	603,15	128,63	0,6404
48	321,15	0,11162	0,9889	106	379,15	1,2504	0,9537	340	613,15	146,05	0,6102
49	322,15	0,11736	0,9884	108	381,15	1,3390	0,9522	350	623,15	165,35	0,5743
50	323,15	0,12335	0,9880	110	383,15	1,4327	0,9507	360	633,15	186,75	0,5275
51	324,15	0,12961	0,9876	112	385,15	1,5316	0,9491	370	643,15	210,54	0,4518
52	325,15	0,13613	0,9871	114	387,15	1,6362	0,9476	374,15	647,30	221,20	0,3154
53	326,15	0,14293	0,9862	116	389,15	1,7465	0,9460				
54	327,15	0,15002	0,9862	118	391,15	1,8628	0,9445				

FLOW RESISTANCE

TABLE OF FLOW RESISTANCE IN BENDS, VALVES AND GATES

The flow resistance is calculated using the equivalent pipeline length method according to the table below:

ACCESSORY TYPE	DN											
	25	32	40	50	65	80	100	125	150	200	250	300
	Equivalent pipeline length (m)											
45° bend	0,2	0,2	0,4	0,4	0,6	0,6	0,9	1,1	1,5	1,9	2,4	2,8
90° bend	0,4	0,6	0,9	1,1	1,3	1,5	2,1	2,6	3,0	3,9	4,7	5,8
90° smooth bend	0,4	0,4	0,4	0,6	0,9	1,1	1,3	1,7	1,9	2,8	3,4	3,9
Union tee or cross	1,1	1,3	1,7	2,1	2,6	3,2	4,3	5,3	6,4	7,5	10,7	12,8
Gate valve	-	-	-	0,2	0,2	0,2	0,4	0,4	0,6	0,9	1,1	1,3
Foot check valve	1,1	1,5	1,9	2,4	3,0	3,4	4,7	5,9	7,4	9,6	11,8	13,9
Non return valve	1,1	1,5	1,9	2,4	3,0	3,4	4,7	5,9	7,4	9,6	11,8	13,9

G-a-pcv-en_b_th

The table is valid for the Hazen Williams coefficient $C=100$ (cast iron pipework);

for steel pipework, multiply the values by 1,41;

for stainless steel, copper and coated cast iron pipework, multiply the values by 1,85;

When the **equivalent pipeline length** has been determined, the flow resistance is obtained from the table of flow resistance.

The values given are guideline values which are bound to vary slightly according to the model, especially for gate valves and non-return valves, for which it is a good idea to check the values supplied by manufacturers.

VOLUMETRIC CAPACITY

Litres per minute l/min	Cubic metres per hour m ³ /h	Cubic feet per hour ft ³ /h	Cubic feet per minute ft ³ /min	Imperial gallon per minute Imp. gal/min	U.S. gallon per minute US gal/min
1,0000	0,0600	2,1189	0,0353	0,2200	0,2642
16,6667	1,0000	35,3147	0,5886	3,6662	4,4029
0,4719	0,0283	1,0000	0,0167	0,1038	0,1247
28,3168	1,6990	60,0000	1,0000	6,2288	7,4805
4,5461	0,2728	9,6326	0,1605	1,0000	1,2009
3,7854	0,2271	8,0208	0,1337	0,8327	1,0000

PRESSURE AND HEAD

Newton per square metre N/m ²	kilo Pascal kPa	bar bar	Pound force per square inch psi	Metre of water m H ₂ O	Millimetre of mercury mm Hg
1,0000	0,0010	1 x 10 ⁻⁵	1,45 x 10 ⁻⁴	1,02 x 10 ⁻⁴	0,0075
1 000,0000	1,0000	0,0100	0,1450	0,1020	7,5006
1 x 10 ⁵	100,0000	1,0000	14,5038	10,1972	750,0638
6 894,7570	6,8948	0,0689	1,0000	0,7031	51,7151
9 806,6500	9,8067	0,0981	1,4223	1,0000	73,5561
133,3220	0,1333	0,0013	0,0193	0,0136	1,0000

LENGTH

Millimetre mm	Centimetre cm	Metre m	Inch in	Foot ft	Yard yd
1,0000	0,1000	0,0010	0,0394	0,0033	0,0011
10,0000	1,0000	0,0100	0,3937	0,0328	0,0109
1 000,0000	100,0000	1,0000	39,3701	3,2808	1,0936
25,4000	2,5400	0,0254	1,0000	0,0833	0,0278
304,8000	30,4800	0,3048	12,0000	1,0000	0,3333
914,4000	91,4400	0,9144	36,0000	3,0000	1,0000

VOLUME

Cubic metre m ³	Litre L	Millilitre ml	Imperial gallon imp. gal.	U.S. gallon US gal.	Cubic foot ft ³
1,0000	1 000,0000	1 x 10 ⁶	219,9694	264,1720	35,3147
0,0010	1,0000	1 000,0000	0,2200	0,2642	0,0353
1 x 10 ⁻⁶	0,0010	1,0000	2,2 x 10 ⁻⁴	2,642 x 10 ⁻⁴	3,53 x 10 ⁻⁵
0,0045	4,5461	4 546,0870	1,0000	1,2009	0,1605
0,0038	3,7854	3 785,4120	0,8327	1,0000	0,1337
0,0283	28,3168	28 316,8466	6,2288	7,4805	1,0000

TEMPERATURE

Water	Kelvin K	Celsius °C	Fahrenheit °F	$^{\circ}\text{F} = ^{\circ}\text{C} \times \frac{9}{5} + 32$ $^{\circ}\text{C} = (^{\circ}\text{F} - 32) \times \frac{5}{9}$
icing	273,1500	0,0000	32,0000	
boiling	373,1500	100,0000	212,0000	

G-at_pp-en_b_sc

**FURTHER PRODUCT SELECTION
AND DOCUMENTATION**
Xylect



Xylect is pump solution selection software with an extensive online database of product information across the entire Lowara range of pumps and related products, with multiple search options and helpful project management facilities. The system holds up-to-date product information on thousands of products and accessories.

The possibility to search by applications and the detailed information output given makes it easy to make the optimal selection without having detailed knowledge about the Lowara products.

The search can be made by:

- Application
- Product type
- Duty point

Xylect gives a detailed output:

- List with search results
- Performance curves (flow, head, power, efficiency, NPSH)
- Motor data
- Dimensional drawings
- Options
- Data sheet printouts
- Document downloads incl dxf files

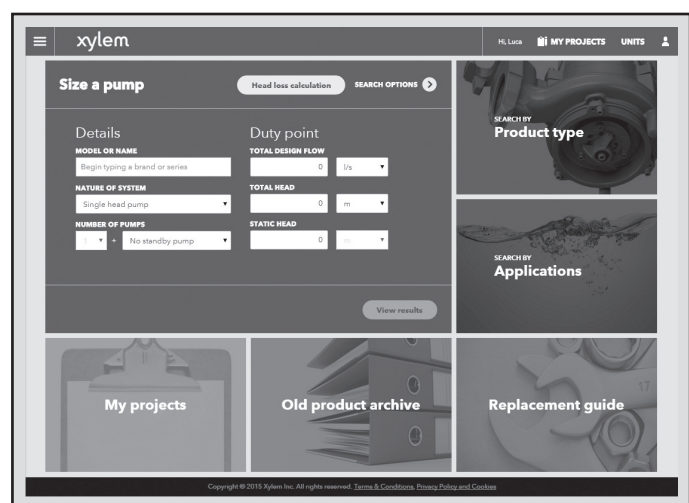

The search by application guides users not familiar with the product range to the right choice.

FURTHER PRODUCT SELECTION AND DOCUMENTATION Xylect



The detailed output makes it easy to select the optimal pump from the given alternatives.

The best way to work with Xylect is to create a personal account. This makes it possible to:

- Set own standard units
- Create and save projects
- Share projects with other Xylect users

Every registered user has a space, where all projects are saved.

For more information about Xylect please contact our sales network or visit www.xylect.com.

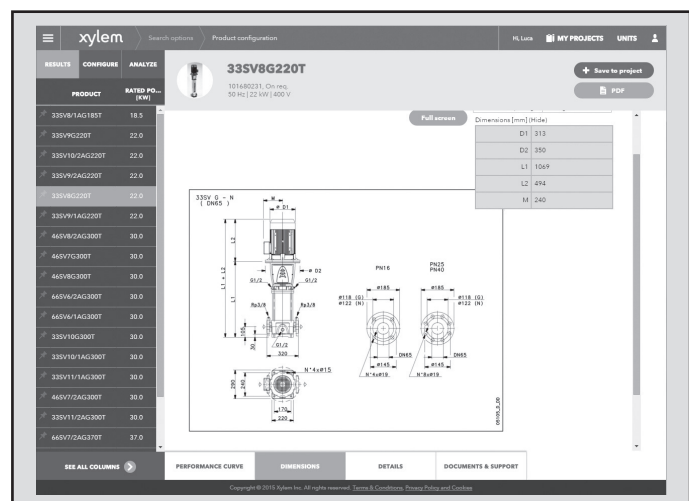

Dimensional drawings appear on the screen and can be downloaded in dxf format.

Xylem |'zīləm|

- 1) The tissue in plants that brings water upward from the roots;
- 2) a leading global water technology company.

We're a global team unified in a common purpose: creating advanced technology solutions to the world's water challenges. Developing new technologies that will improve the way water is used, conserved, and re-used in the future is central to our work. Our products and services move, treat, analyze, monitor and return water to the environment, in public utility, industrial, residential and commercial building services settings. Xylem also provides a leading portfolio of smart metering, network technologies and advanced analytics solutions for water, electric and gas utilities. In more than 150 countries, we have strong, long-standing relationships with customers who know us for our powerful combination of leading product brands and applications expertise with a strong focus on developing comprehensive, sustainable solutions.

For more information on how Xylem can help you, go to www.xylem.com/uk



Xylem Water Solutions UK Ltd.

Main Office

Private Road No.1
Colwick, Nottingham NG4 2AN
Tel 0115 940 0111
Email fgbsales@xyleminc.com
www.xylem.com/uk

Axminster Office

Millwey Rise Industrial Estate
Axminster, Devon EX13 5HU
Tel 01297 630 230
Email lowaraukenquiries@xyleminc.com
www.xylem.com/uk

Xylem Water Solutions Ireland Ltd.

50 Broomhill Close
Airton Road, Tallaght, Dublin 24
Tel (+353) 01 4524 444
Email flygtIRL@xyleminc.com
www.xylem.com/ie

Xylem Maintenance Agreements UK

Tel 0800 009 3611

Xylem Service & Rental UK

24/7 Rental & Service Call Centre
Tel 0845 707 8012

Xylem Water Solutions UK Limited reserves the right to make modification without prior notice.

Lowara, Xylem are trademarks of Xylem Inc. or one of its subsidiaries
© 2022 Xylem, Inc.