



# HVAC OEM CIRCULATORS

HIGH EFFICIENCY WET ROTOR CIRCULATORS FOR HEATING, COOLING, DOMESTIC HOT WATER AND SOLAR THERMAL APPLICATIONS





## SUMMARY

GENERAL INTRODUCTION.....	<b>4</b>
RANGE OVERVIEW.....	<b>4</b>
APPLICATIONS AND RECOMMENDED MODELS.....	<b>5</b>
Energy-related Products Directive (2009/125/EC Directive) .....	<b>6</b>
MODEL DESCRIPTION.....	<b>7</b>
IDENTIFICATION CODE.....	<b>10</b>
HYDRAULIC PERFORMANCE RANGE.....	<b>11</b>
CONTROL MODES.....	<b>13</b>
Constant pressure .....	<b>13</b>
Proportional pressure .....	<b>14</b>
Constant Speed.....	<b>15</b>
Automatic air Purge mode .....	<b>15</b>
PWM .....	<b>16</b>
HUMAN MACHINE INTERFACE.....	<b>20</b>
APPLICATIONS .....	<b>22</b>
OPERATING CONDITIONS .....	<b>24</b>
CONTROL BOX POSITION.....	<b>25</b>
EXPLODED VIEW AND MAIN COMPONENTS .....	<b>26</b>
PUMP HOUSING .....	<b>28</b>
CONNECTIONS .....	<b>29</b>
DIMENSIONS AND TECHNICAL DATA, PERFORMANCE CURVES.....	<b>30</b>
eco2 .. 4/(N) SERIES.....	<b>30</b>
eco2 .. 6/(N) SERIES.....	<b>32</b>
eco2 .. 8/(N) SERIES.....	<b>34</b>
eco2 15-6/End SERIES .....	<b>36</b>
eco2 15-8/END SERIES .....	<b>38</b>
eco2 ..-4/130 C SERIES.....	<b>40</b>
eco2 ..-6/130 C SERIES.....	<b>42</b>
eco2 ..-8/130 C SERIES.....	<b>44</b>
eco2S ..-8/ SERIES .....	<b>46</b>
eco2S ..-15/ SERIES .....	<b>48</b>
eco2 SERIES IN BRIEF.....	<b>50</b>

## eco2 RANGE OVERVIEW

eco2 is the brand new Lowara OEM range of residential circulators for heating, cooling, solar thermal and domestic hot water applications.















Series name	eco2		
			
<b>RANGE</b>			
# of variants	112	24	12
Models	4, 6, 8	8, 15	6, 8
Pump housing material	Cast Iron Stainless Steel Composite	Cast Iron	Cast Iron
<b>CONNECTION</b>			
Cable Gland	X	X	X
Superseal plug	X	X	X
Mini Superseal plug	X	X	X
<b>CONTROL MODE AND COMMUNICATION</b>			
Proportional pressure	X	X	
Constant pressure	X	X	
Constant speed	X	X	
PWM	X	X	X
<b>DUTY RANGE</b>			
Maximum Flow	3,7 m <sup>3</sup> /h	3,5 m <sup>3</sup> /h	3,7 m <sup>3</sup> /h
Maximum Head	8 m	15 m	8 m
Maximum System Pressure	10 bar (1 MPa)		
Liquid Temperature	-10°C to +110 °C heating and cooling systems (max +95°C for composite version)		
Ambient temperature during operation *	-10°C to +55°C		
Enclosure Class	IP 44		
Insulation class	155 (F)		
Power Supply	Single phase 230 V ± 10 %, 50/60 Hz		
Sound pressure level	≤ 43 dB(A)	≤ 43 dB(A)	≤ 43 dB(A)
EEl level **	≤ 0,20	≤ 0,20	≤ 0,20

En\_revA

\* To avoid the formation of condensate in the electronic drive and stator, the temperature of the liquid must be kept above room temperature.

\*\* For EEl value of each model see pages 30ff.

## eco2 APPLICATIONS AND RECOMMENDED MODELS

Series name	eco2			eco2 SOLAR			eco2 MICROFLOW		
									
<b>APPLICATIONS</b>									
Gas and oil-fired boilers		X**							X
Wood heaters		X							X
Heat pumps		X**							X
Heat interface units		X**							X
Direct heating		X							
Indirect heating		X							
Domestic hot water systems		X*							
Fresh water modules		X							X
Circulating pump		X**							X
Underfloor heating		X**							X
Thermal solar systems						X			

En\_revA

\* - only with stainless steel pump housing (suitable even for drinkable water application)

\*\* - available with composite pump housing.

For more details see "APPLICATIONS" chapter.

## ErP

### Energy-related Products Directive (2009/125/EC Directive)

The **Directive 2005/32/EC** on energy-using products (**EuP**) and the subsequent **Directive 2009/125/EC** on energy-related products (**ErP**) established the ecodesign requirements for products to reduce their energy consumption and consequently their environmental impact.

These requirements apply to products placed and used in the European Economic Area (European Union plus Iceland, Liechtenstein and Norway) as a stand-alone unit or as integrated parts in other products.

Circulators are subject to EU ecodesign requirements, which cover energy efficiency index (EEI) and product information, if designed for use in a closed system, such as hot water in boiler systems, solar systems and heat pump systems or cooling water in cooling distribution systems.

For drinking water circulators only product information requirements to apply.

The Regulations that define the requirements for glandless circulators are:

Product	Regulations	From	Target
Circulators*	(EC) No 641/2009, (EU) No 622/2012, (EU) 2019/1781	1 August 2015	<b>EEI</b> < 0,23

\* circulators with a rated hydraulic output power of between 1 and 2500 W, designed for use in heating systems or in secondary circuits of cooling distribution systems.

#### Regulations (EC) No 641/2009 and (EU) No 622/2012 – Annex I – point 2 (Product information requirements)

- a) Energy efficiency index: see the EEI column in the tables in the Hydraulic performance section.
- b) "The benchmark for most efficient circulators is  $EEI \leq 0,20$ ".
- c) Information relevant for disassembly, recycling or disposal at end-of-life: observe the current laws and by-laws governing sorted waste disposal. Consult the product operating manual.
- d) Information for circulators specifically designed to potable water uses: note not applicable to these products.

**eco2**

**PRODUCT FEATURES**

- Flow rate: up to 3,7 m<sup>3</sup>/h
- Head: up to 8 m
- Maximum Power Consumption: 55 W
- Automatic Air-purge
- Pump housings: cast iron, stainless steel, composite
- Operating Modes: proportional pressure, constant pressure, constant speed
- Power connection: cable gland, Superseal plug
- Human Machine Interface: multifunctional knob to set up all pump functionalities; 1 led to read pump status

**APPLICATIONS**

- Water circulation in heating systems (boilers, mixing units, CHP, ...)
- Water circulation in air conditioning systems (air to water heat pumps)
- Domestic Hot Water systems

**eco2 PWMH**

**PRODUCT FEATURES**

- Flow rate: up to 3,7 m<sup>3</sup>/h
- Head: up to 8 m
- Maximum Power Consumption: 55 W
- Automatic Air-purge
- Pump housings: cast iron, stainless steel, composite
- Communication protocol: PWMH
- Power connection: cable gland, Superseal plug
- Communication connection: cable gland, Mini Superseal plug
- Human Machine Interface: 1 led to read pump status

**APPLICATIONS**

- Water circulation in heating systems (boilers, mixing units, CHP, ...)
- Water circulation in air conditioning systems (air to water heat pumps)
- Domestic Hot Water systems



## eco2 SOLAR



### PRODUCT FEATURES

- Flow rate: up to 3,5 m<sup>3</sup>/h
- Head: up to 15 m
- Maximum Power Consumption: 52 W
- Automatic Air-purge
- Pump housings: cast iron
- Operating Modes: proportional pressure, constant pressure, constant speed
- Power connection: cable gland, Superseal plug
- Human Machine Interface: multifunctional knob to set up all pump functionalities; 1 led to read pump status

### APPLICATIONS

- Water circulation in solar thermal systems.



## eco2 SOLAR PWMS



### PRODUCT FEATURES

- Flow rate: up to 3,5 m<sup>3</sup>/h
- Head: up to 15 m
- Maximum Power Consumption: 52 W
- Pump housings: cast iron
- Communication protocol: PWMS
- Power connection: cable gland, Superseal plug
- Communication connection: cable gland, Mini Superseal plug
- Human Machine Interface: 1 led to read pump status

### APPLICATIONS

- Water circulation in solar thermal systems



## eco2 MICROFLOW PWMM PRODUCT FEATURES



- Flow rate: up to 3,7 m<sup>3</sup>/h
- Head: up to 8 m
- Maximum Power Consumption: 55 W
- Pump housings: cast iron, stainless steel, composite
- Communication protocol: PWMM
- Power connection: cable gland, Superseal plug
- Communication connection: cable gland, Mini Superseal plug
- Human Machine Interface: 1 led to read pump status

## APPLICATIONS

- Fresh Water Module
- Low flow heating systems



**eco2**  
**IDENTIFICATION CODE**

eco2 S PWMS 15 - 8 / 130 [ ] CG

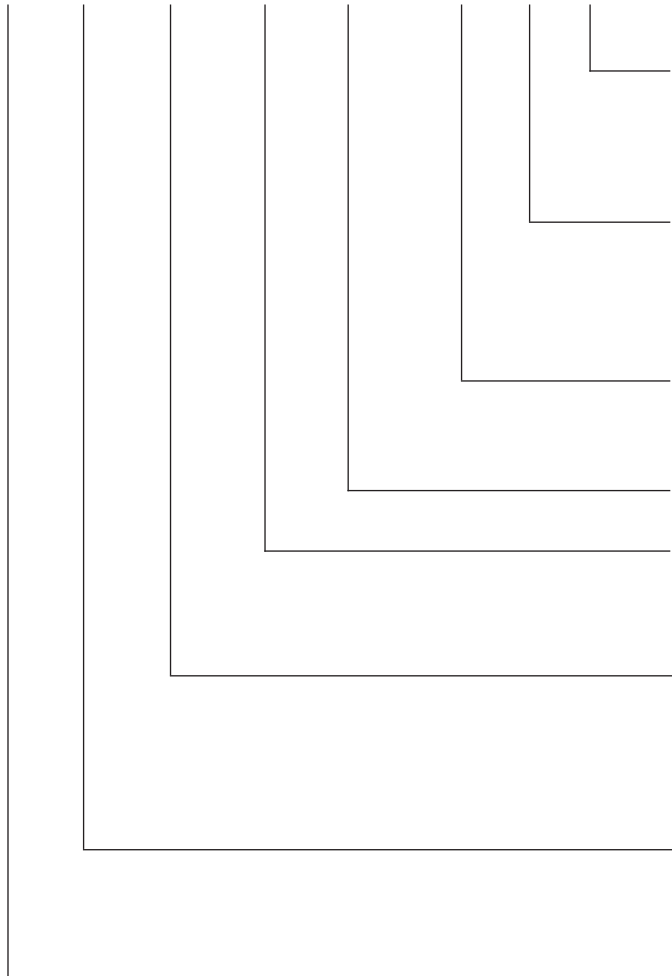

**CONNECTION TYPE:**

CG = Cable Gland  
TS = Superseal and Mini-Superseal plug

**PUMP TYPE:**

'empty' = Cast iron  
N = Stainless steel  
C = Composite

**PORT TO PORT DISTANCE**

130 = 130 mm  
180 = 180 mm  
END = End suction version

**MAXIMUM HEAD IN m**

**PORT NOMINAL DIAMETER**

**OPERATING MODE:**

'empty' = basic control modes  
'PWMH' = version with PWM heating profile  
'PWMS' = version with PWM solar profile  
'PWMM' = version with PWM microflow profile

**PRODUCT VERSION**

'empty' = standard eco2 series  
'S' = eco2 SOLAR series  
'M' = eco2 MICROFLOW series

**PRODUCT FAMILY**

eco2 series



**eco2**

**HYDRAULIC PERFORMANCE RANGE**

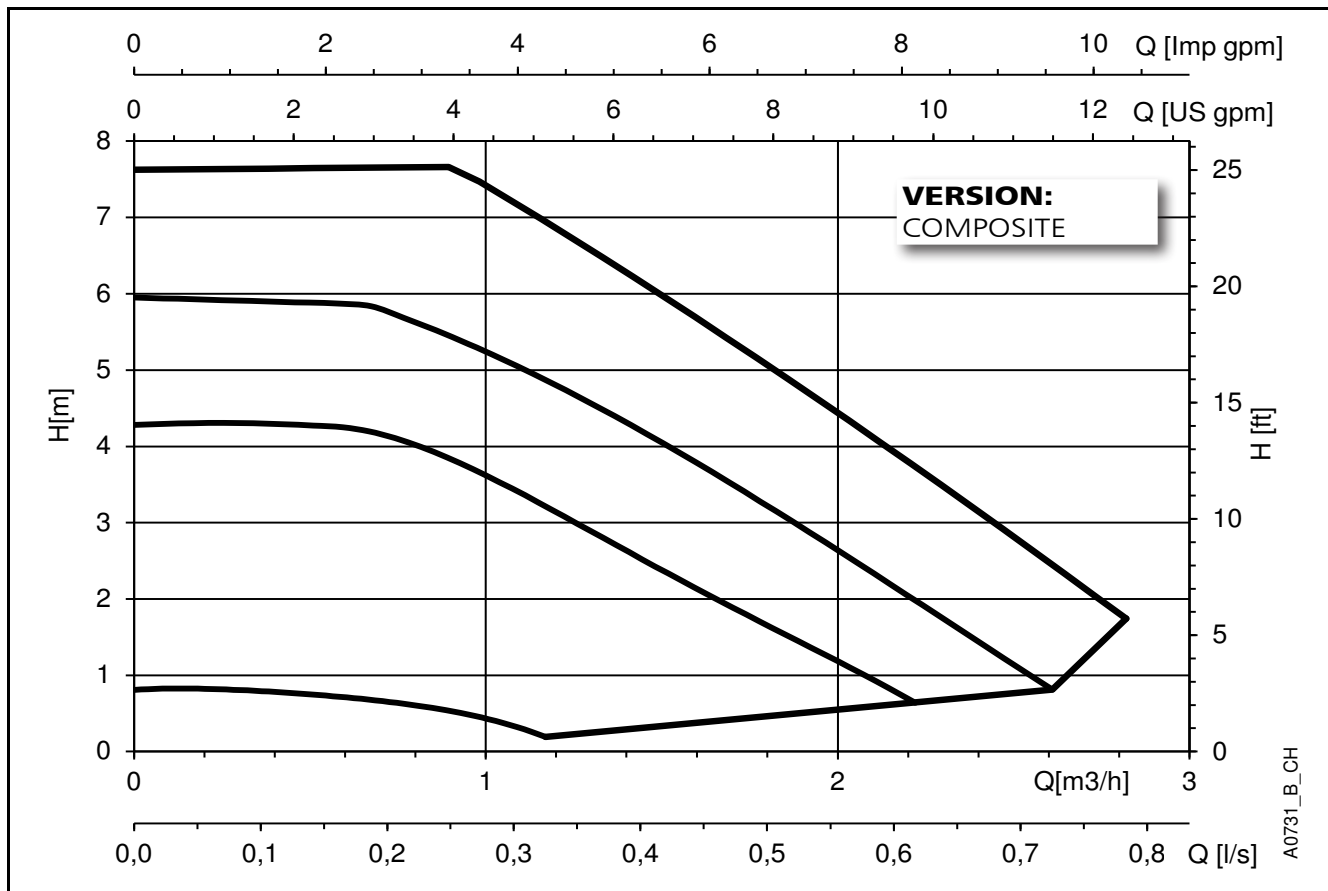
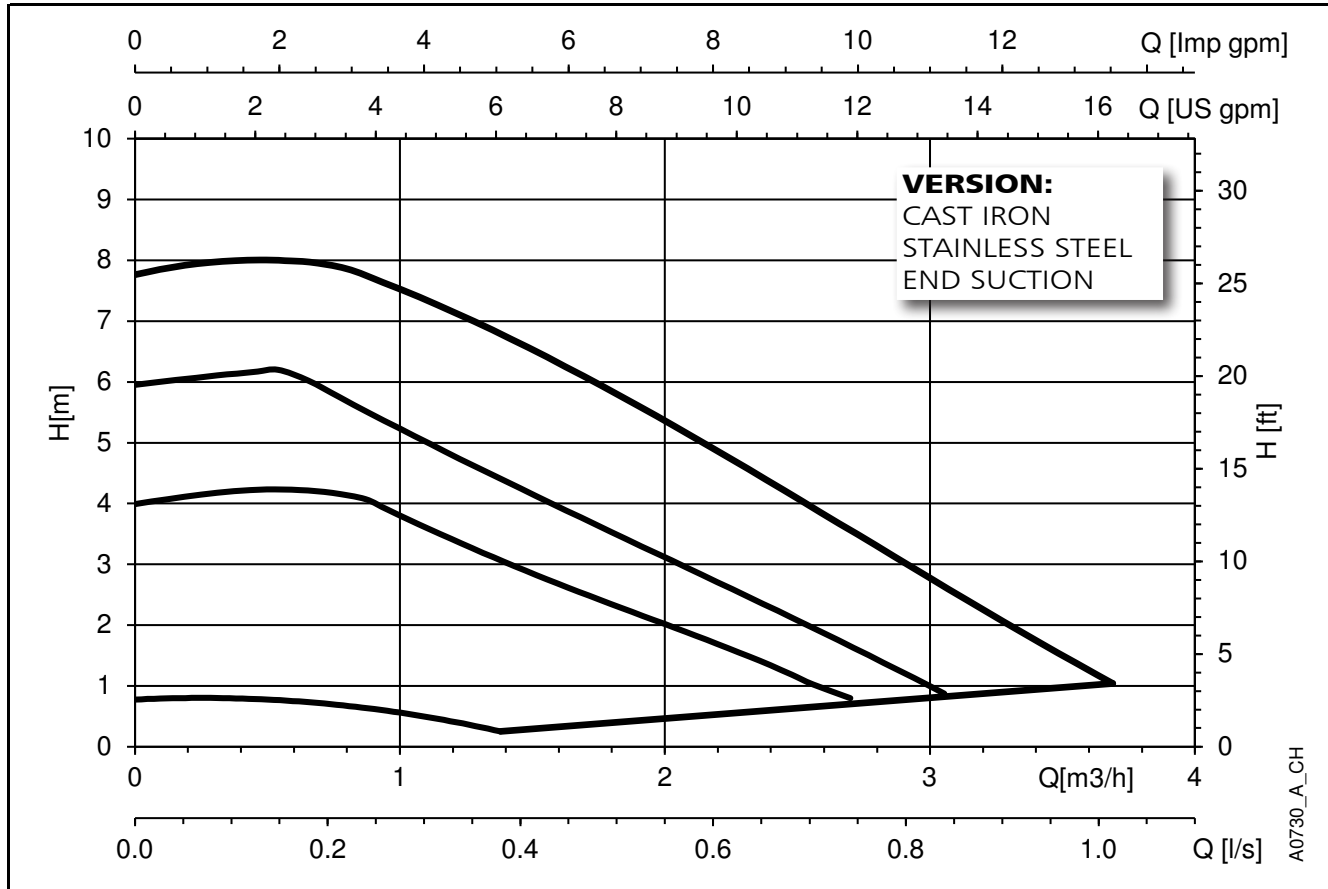

**eco2 SOLAR  
HYDRAULIC PERFORMANCE RANGE**

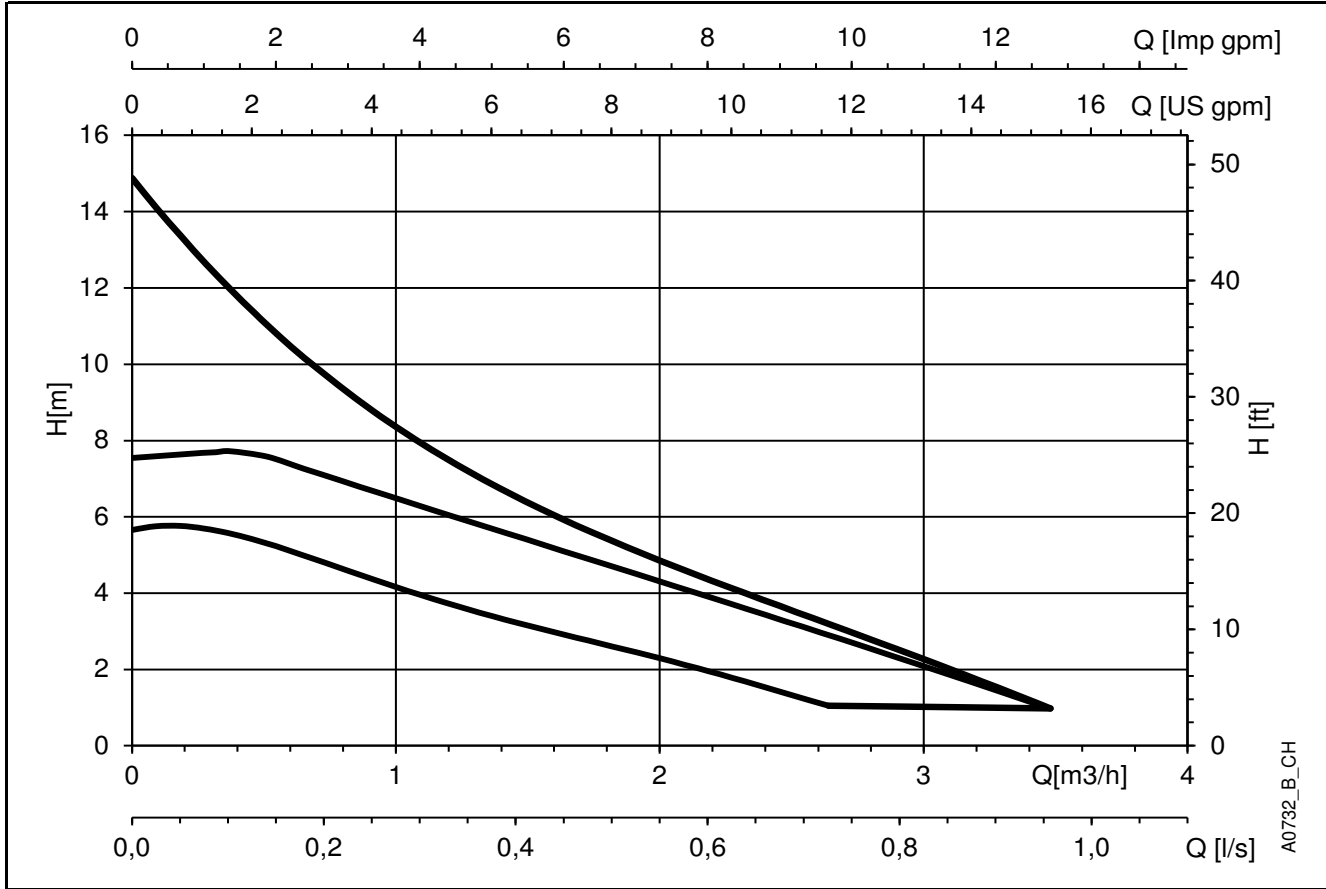

**eco2**  
**CONTROL MODES**

eco2 and eco2 SOLAR series can be operated with 3 different functional modes: constant pressure, proportional pressure and constant speed.

**Constant pressure**

The pump maintains a constant pressure at any flow demand. The desired head of the pump can be set via user interface selecting 1, 2 or 3 performance curve (see picture below).

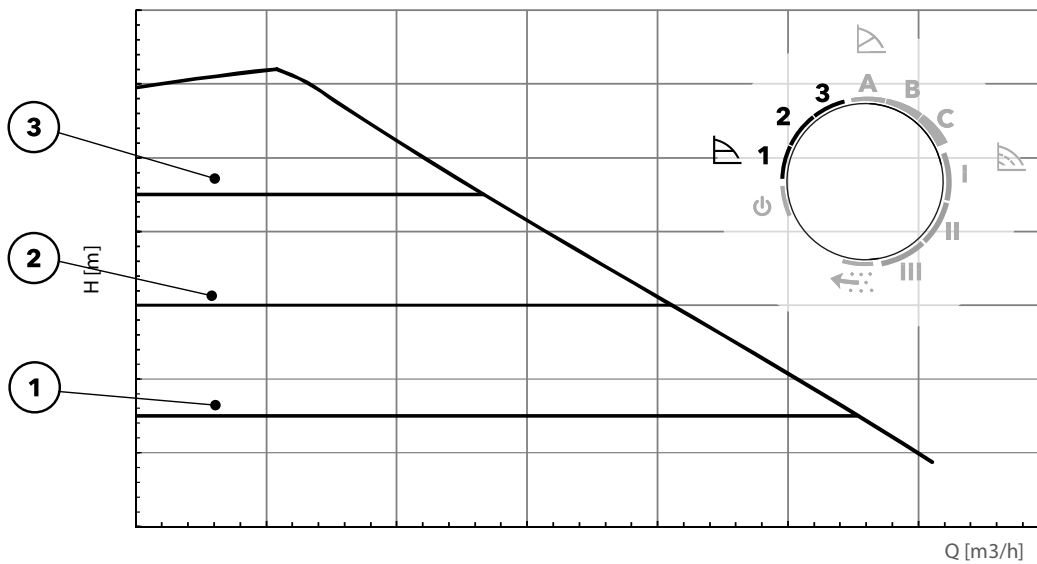

Constant pressure control is ideal for systems in which the distribution pipe is non-existent or very short. A prime example is **underfloor heating**. The distribution pipe consists in most cases of an extremely short pipe run and the manifold. In such cases, system resistance is negligible.

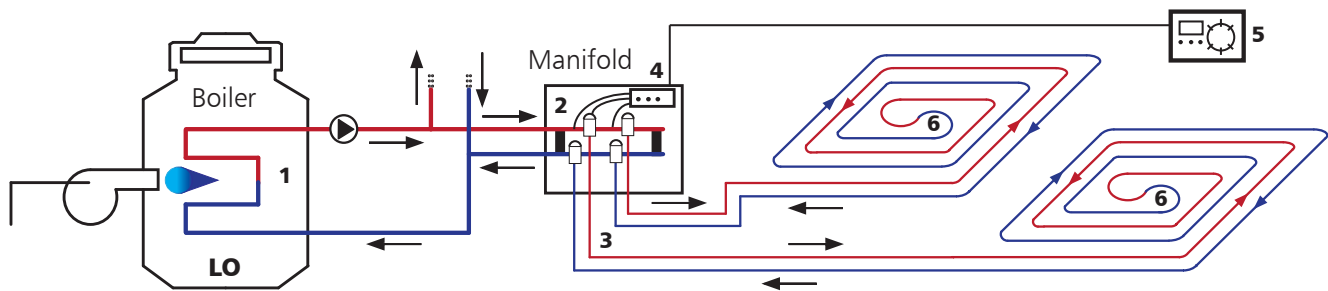

**eco2**  
**CONTROL MODES**

**Proportional pressure**

At proportional pressure control the pump pressure is continuously increased / decreased depending on the flow demand. The maximum head can be set via user interface selecting A, B or C performance curve (see picture below).

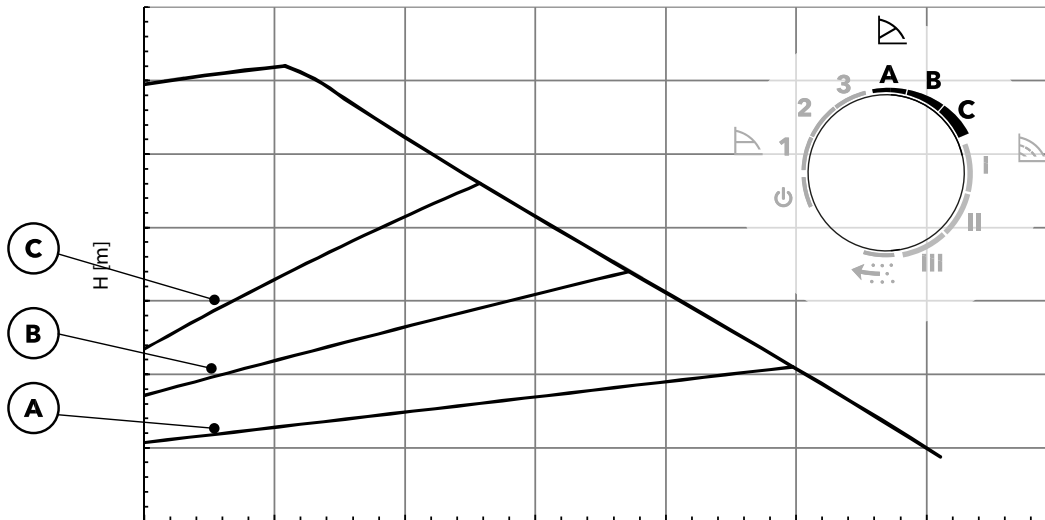

Proportional pressure functional mode is recommended in systems with relatively large pressure losses in the distribution pipes such as **radiator heating loops**.

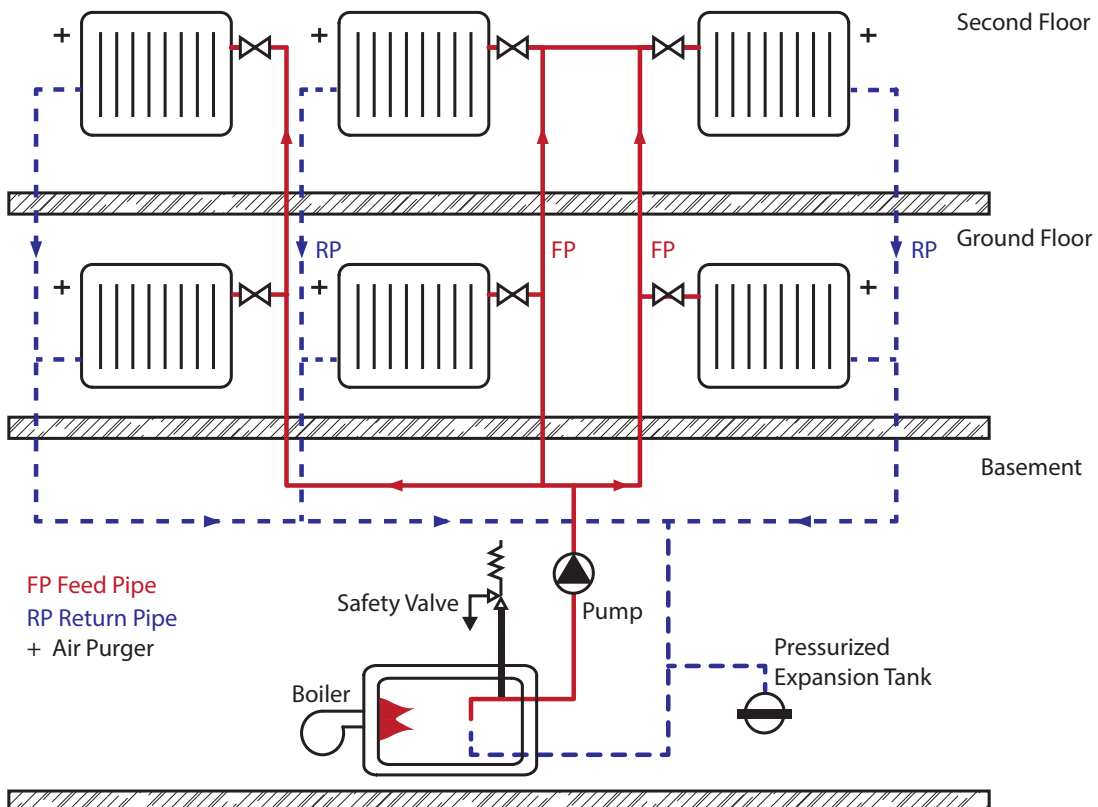

**eco2  
CONTROL MODES**

**Constant Speed**

At constant curve/constant speed the pump maintains a fixed speed at any flow demand. The speed of the pump can be set via user interface selecting I, II or III performance curve.

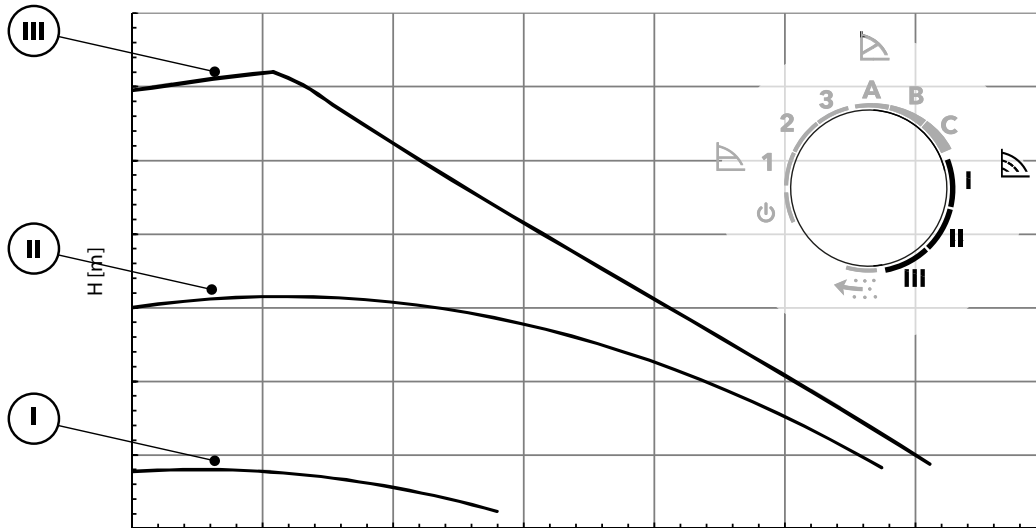

Constant speed control is the most common when used in the primary or boiler loop in a primary/secondary hydronic system.

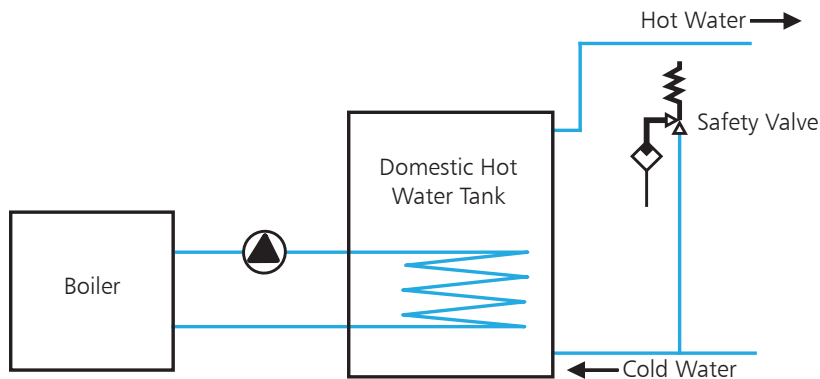

**Automatic air Purge mode**

The automatic air purge mode allows a quick automatic air-venting for a safe operation. This function can be also set up manually by the installer to ensure a complete air-venting. When the air purge mode is selected on the HMI, the pump runs at its maximum speed. If another operating mode is selected after the air purge mode, the pump continues to run at maximum speed for 3 minutes in air purge mode and then it switches to the newly selected operating mode.



**eco2  
CONTROL MODES**

**PWM**

eco2 PWMH, eco2 SOLAR PWMS and eco2 MICROFLOW PWMM are controlled via PWM (pulse-width modulation) signal for external activation of functions. The set point level assessment required for control is referred to a remote controller. The remote controller sends a PWM signal as an actuating variable to the circulator.



**Heating profile - PWMH** (according to VDMA 24224)

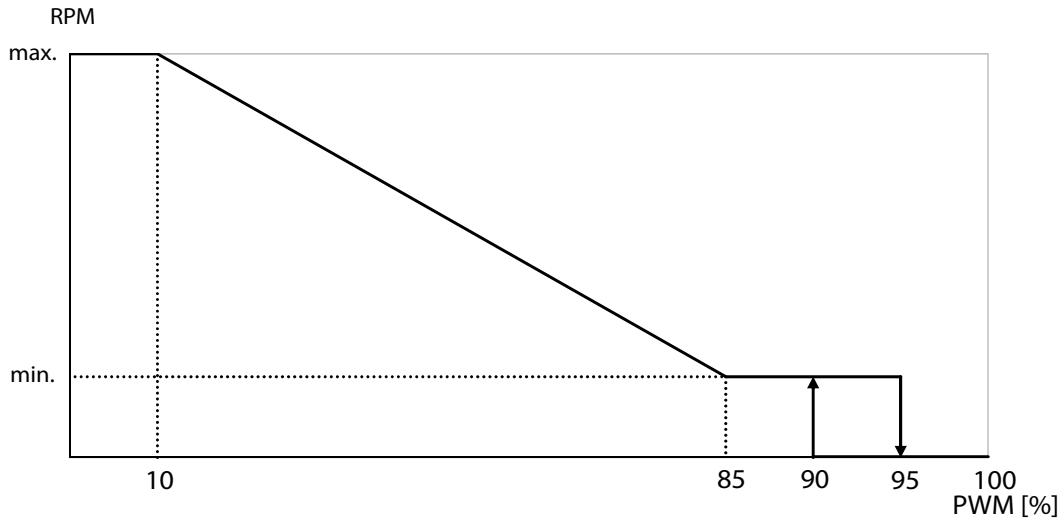

PWM input signal [%]	Operating status
< 10	Pump runs at maximum speed
10 - 85	Pump speed decreases linearly from maximum to minimum
85 - 95	Pump runs at minimum speed (operation)
85 - 90	Pump runs at minimum speed (start-up)
90 - 100	Pump stops (stand-by)

Specifications:	
Signal amplitude:	4,5 V - 15 V
Signal frequency:	100 – 1000 Hz
Current absorbed by the pump:	10 mA
Signal polarity:	(+) = green, (-) = white

en\_revA

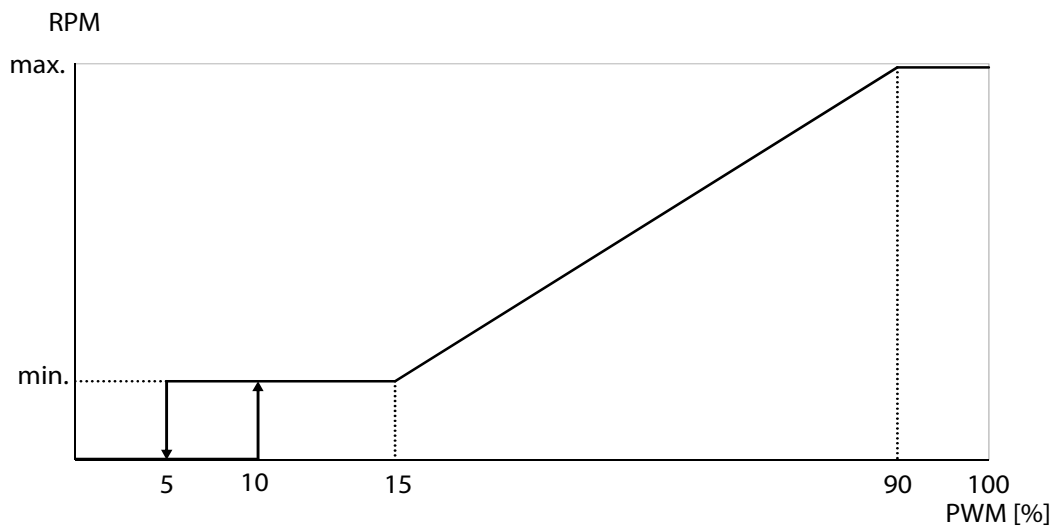
**eco2**  
**CONTROL MODES**
**Solar profile - PWMS** (according to VDMA 24224)

PWM input signal [%]	Operating status
< 5	Pump stops (stand-by)
5 - 15	Pump runs at minimum speed (operation)
10 - 15	Pump runs at minimum speed (start-up)
15 - 90	Pump speed increases linearly from minimum to maximum
90 - 100	Pump runs at maximum speed

Specifications:	
Signal amplitude:	4,5 V - 15 V
Signal frequency:	100 – 1000 Hz
Current absorbed by the pump:	10 mA
Signal polarity:	(+) = green, (-) = white

en\_revA

## eco2 CONTROL MODES

### Microflow profile - PWMM

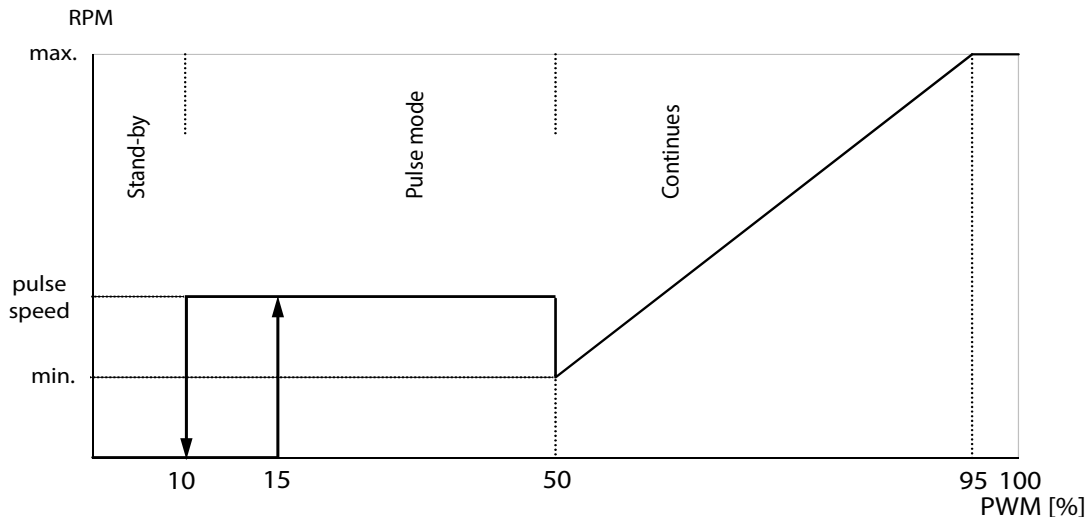

PWM input signal [%]	Operating status	Pump mode
< 10	Pump stops (stand-by)	Stand-by
10 - 15	Hysteresis between stand-by and pulse mode	Stand-by
15 - 50	Pump in pulse mode (alternating run / stand-by mode)	Pulse mode
50 - 95	Pump speed increases linearly from minimum to maximum	Continues
95 - 100	Pump runs at maximum speed	Continues

Specifications:	
Signal amplitude:	4,5 V - 15 V
Signal frequency:	100 – 1000 Hz
Current absorbed by the pump:	10 mA
Signal polarity:	(+) = green, (-) = white

en\_revB

#### NOTES:

Between 15% and 50% of PWM signal, the pump will alternate between stand-by mode and constant speed (equal to double the minimum speed) in order to partialize the flow. Ratio between running mode and stand-by mode starts from 2,5% and increases up to 50% with 50% of PWM signal. Above 50% of PWM signal the device is always in running mode with linear increasing of the speed.

## eco2 MONITORING FEATURES

### PWM output signal [%]

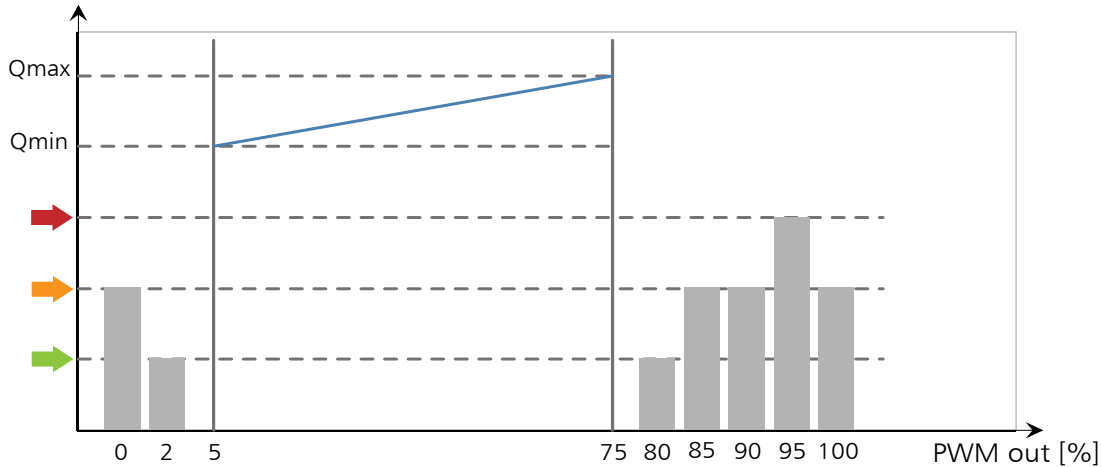

PWM output signal [%]	Operating status
0	→ PWM output interface damaged
2	→ Stand-by
5 - 75	Pump is running, flow or power information is returned
80	→ Abnormal running mode, pump is running but not at optimal performance
85 - 90	→ Abnormal function mode, pump is stopped momentarily but is still functional
95	→ The pump is stopped due to permanent failure
100	→ Pump power OFF or PWM output interface damaged

Specifications:	
Type:	Open collector
Frequency:	75 Hz
High voltage level:	3 to 25 V
Max. voltage from master PWM:	32 V
Max. current in abnormal operation:	10 mA
Input series resistors:	470 Ω

The values for Qmin/Qmax are reported in the following table:

Parameter	Unit	Value	
		Heating	Solar
Output of Volume Flow	%	5 to 75	5 to 75
eco2.. 4m	m <sup>3</sup> /h	0 to 2,3	
eco2.. 6m	m <sup>3</sup> /h	0 to 2,8	
eco2.. 8m	m <sup>3</sup> /h	0 to 3,3	0 to 3,0
eco2.. 15m	m <sup>3</sup> /h		0 to 3,0

The error or alarm causes are summarized via PWM output using the following scheme:

%	Error name	Error Code	Error Type
95	Driver Fault	E05	Final Error
	Phase loss	E09	Final Error
	Motor Overload	E07	Final Error
	Dry Run (24h)	E10	Final Error
90	Loss of sync / Blocked Rotor	E04	Error
	Overcurrent	E02	Error
85	Undervoltage	E06	Error
	Overvoltage	E03	Error
	Overtemperature	E08	Error
80	Dry Run detected	Red LED Blinking	Alarm

**eco2**  
**HUMAN MACHINE INTERFACE**

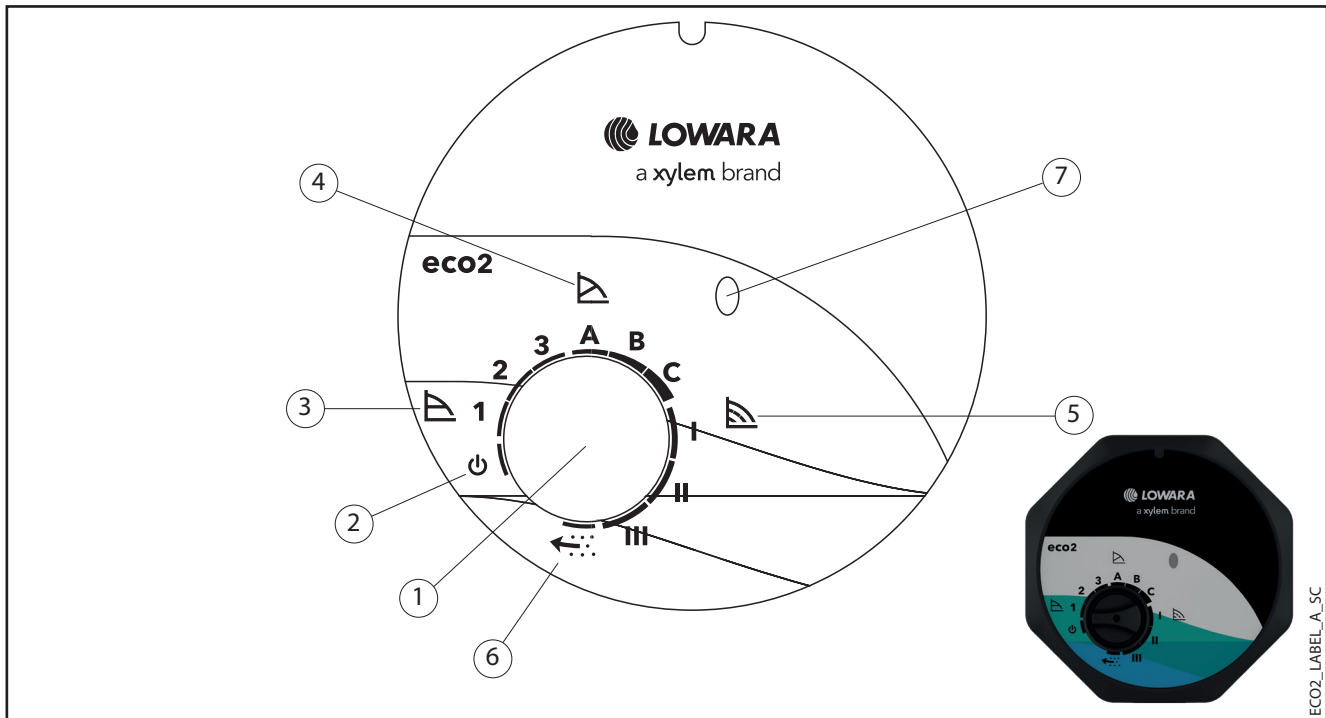

Ref.	Function	Description
1	<b>Knob</b>	Operating modes change by turning the knob
2	⏻	Stand-by mode
3	▴	Constant pressure control at 1, 2 or 3 performance curve
4	▴	Proportional pressure control at A, B or C performance curve
5	▴	Constant speed control at I, II or III performance curve
6	↶	Automatic Air Purge function
7	<b>Control mode LED</b>	Multicolor LED showing circulator status
	GREEN (Fixed)	Circulator is working properly
	GREEN (Blinking)	Automatic Air-Purge function is running
	YELLOW (Blinking)	Stand-by
	RED (Fixed)	Pump failure
	RED (Blinking)	Dry run

**eco2 PWM  
HUMAN MACHINE INTERFACE**

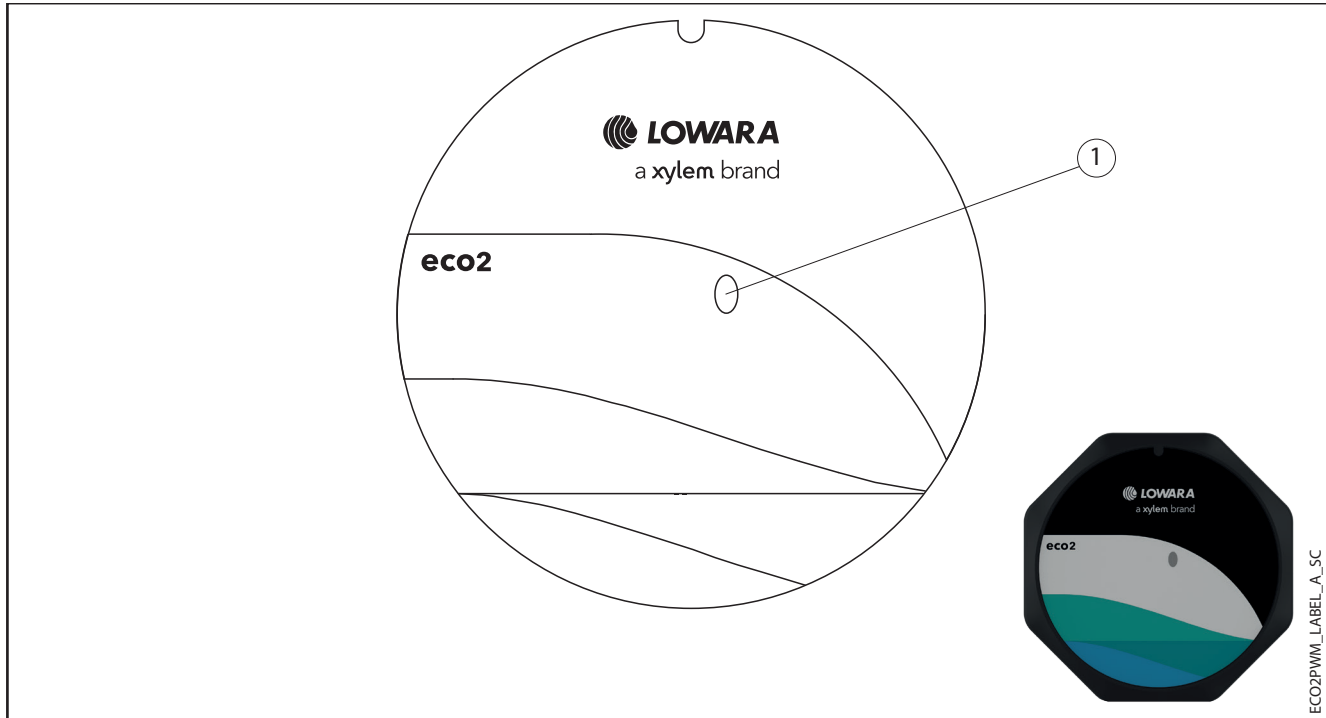

Ref.	Function	Description
1	<b>Control mode LED</b>	Multicolor LED showing circulator status
	GREEN (Fixed)	Circulator is working properly
	YELLOW (Blinking)	Stand-by
	RED (Fixed)	Pump failure
	RED (Blinking)	Dry run

En-RevA

## eco2 APPLICATIONS



Heat and cooling systems



Residential building

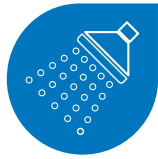

Domestic hot water systems

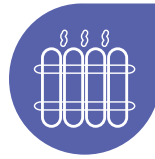

Systems with thermostatic radiator valves



Underfloor heating systems



Thermal solar systems

## GAS AND OIL-FIRED BOILERS

Boilers are water heaters fueled by gas or oil: fuel is burned and the hot gases produced pass through a heat exchanger where much of their heat is transferred to water, thus raising the water's temperature. One of the hot gases produced in the combustion process is water vapour (steam), which arises from burning the hydrogen content of the fuel.

More and more of these heaters are condensing boilers: they achieve high efficiency (typically greater than 90% on the higher heating value) by using waste heat in flue gases to pre-heat cold water entering the boiler.

Water vapour produced during combustion is condensed into liquid form, which leaves the system via a drain. Boilers can be for heating only or for both heating systems and domestic hot water production. Heaters are mostly controlled by a weather-compensating system controller with different time programs, which means the central heating water temperature is often lower than the domestic hot water temperature.

In systems with domestic hot water supply either as combination heaters with integrated DHW supply or with external DHW tank or heat exchanger there is a need to increase the medium temperature temporarily above DHW temperature level.

In small residential buildings, the heating demand for DHW is higher than for space heating. Internal or external circulator pumps for these primary circuits must be controlled by the needs of the heaters to optimize the combustion conditions and the condensation process.

Often this can only be guaranteed by using a variable speed circulator pump with external control signal from the boiler controller.

## WOOD HEATERS

Pellet burning stoves hydro are designed to yield all the heat they produce to the water of the heating and domestic water systems.

The entire hydraulic system needed to make them function is already supplied in the stove: an expansion tank, a safety valve, a relief valve, a manometer, a circulator and an anti-condensing valve.

## HEAT PUMPS

A heat pump is a device that provides heat energy from a source of heat to a destination called a "heat sink".

Heat pumps are designed to move thermal energy opposite to the direction of spontaneous heat flow by absorbing heat from a cold space and releasing it to a warmer one.

While air conditioners and freezers are familiar examples of heat pumps, the term "heat pump" is more general and applies to many HVAC (heating, ventilating, and air conditioning) devices used for space heating or space cooling.

When a heat pump is used for heating, it employs the same basic refrigeration-type cycle used by an air conditioner or a refrigerator, but in the opposite direction - releasing heat into the conditioned space rather than the surrounding environment.

In this use, heat pumps generally draw heat from the cooler external air or from the ground. In heating mode, heat pumps are three to four times more efficient in their use of electric power than simple electrical resistance heaters. Heating pumps are, due to their high annual operating hours, among the largest power-consuming appliances in buildings. After the compressor in heat pumps and in other systems of heating applications, the circulation pump is the biggest consumer of electrical power and is therefore the major efficiency factor for the entire application. Automatic pump performance control helps drastically to reduce power consumption in heating pumps.

## **eco2 APPLICATIONS**

### **DIRECT HEATING**

Direct heat interface units facilitate a direct connection between the primary system and the secondary system. Domestic hot water is provided by a plate heat exchanger.

### **INDIRECT HEATING**

Indirect heat interface units facilitate a separation between the primary and secondary systems, with a plate heat exchanger to transfer energy from fluid in the primary system to fluid in the secondary system. In installations where separation between the primary and secondary systems is required, indirect heat interface units provide this.

### **DOMESTIC HOT WATER SYSTEM**

A typical configuration of a DHW system is a boiler working in tandem with a heat exchanger and hot water tank. The systems can be fired by natural gas, oil, propane or electricity. The potable water is usually stored in a tank next to the boiler and heated indirectly by primary heating water either by an external plate heat exchanger or by an internal indirect coil. This process continues until the water in the tank reaches the required temperature.

### **FRESH WATER MODULES**

The fresh water modules are stations that instantaneously heat up domestic water, when required, by exploiting the heating water stored in a buffer cylinder. When there is demand for domestic hot water from a user, fresh DHW heats up through the fresh water module, cooling down the heating water in the cylinder. A plate heat exchanger offers very efficient heat transfer and keeps the two flows completely separated. This separation is required to satisfy restrictive regulations in terms of water temperature, health measures and maintenance operations.

### **CIRCULATING PUMP**

The secondary circulator pump is often a self-controlled stand-alone circulator pump, which can be mounted in a heating kit, and responds to the changing flow demand of heat consumers like radiators or underfloor heating circuits. Providing the best operating conditions for all components, hydraulic balancing is important for well-performing hydraulic systems.

Especially in 2-pipe heating systems with thermostatic valves, hydraulic balancing helps to avoid noises, oversupply, undersupply, too high pump performance, and saves energy. If an automatic bypass valve is installed to ensure a minimum flow, you must adjust the differential pressure control of the circulator pump in a way to ensure the function of the automatic bypass valve.

### **THERMAL SOLAR SYSTEMS**

Solar water heating (SWH) is the conversion of sunlight into renewable energy for water heating using a solar thermal collector. Solar water heating systems comprise various technologies that are used worldwide increasingly.

In a "close-coupled" SWH system the storage tank is horizontally mounted immediately above the solar collectors on the roof. No pumping is required as the hot water naturally rises into the tank through thermosiphon flow.

In a "pump-circulated" system the storage tank is ground- or floor-mounted and is below the level of the collectors; a circulating pump moves water or heat transfer fluid between the tank and the collectors. SWH systems are designed to deliver hot water for most of the year.

However, in winter there sometimes may not be sufficient solar heat gain to deliver sufficient hot water.

In this case a gas or electric booster is used to heat the water.

**eco2**
**OPERATING CONDITIONS**

Feature	Specification
Nominal supply voltage	1 x 230 V $\pm$ 10 % 50/60 Hz.
Motor protection	The motor is protected by the electronics in the control box and requires no external motor protection.
Degree of protection (IEC 60529)	IP 44
Insulation thermal class (IEC 60085)	155 (F)
Equipment class (EN 60335-1)	I
Temperature class (EN 60335-2-51)	TF110 (at 55 °C ambient temperature).
Standby power consumption	< 0.8 W
Transport	The unit can be transported only as indicated on the packaging, at an ambient temperature from -40°C to 85°C and must be protected against dirt, heat source and mechanical damage.
Storage temperature	-40 to +85 °C, with humidity maximum 95% at 40°C.
Operating ambient temperature	0 to 55 °C. - (for higher ambient temperature requirements please contact Xylem representatives)
Relative air humidity	Maximum 95 %, non-condensing environment.
Maximum altitude of installation	2000 m above sea level.
Pumped liquids	<p>The pump is suitable for liquids</p> <ul style="list-style-type: none"> <li>• thin (watery),</li> <li>• clean,</li> <li>• free of abrasive, solid or fibrous substances,</li> <li>• chemically and mechanically non-aggressive,</li> <li>• non-flammable,</li> <li>• non-explosive,</li> <li>• non-toxic,</li> <li>• free of mineral oils,</li> <li>• water/glycol mixtures.</li> </ul> <p>In addition, the pump is not suitable for liquids</p> <ul style="list-style-type: none"> <li>• potable other than water,</li> <li>• foodstuffs,</li> <li>• not compatible with the pump construction materials.</li> </ul>
General recommendation for water	<ul style="list-style-type: none"> <li>• Water in heating systems: according to VDI 2035-1 (German standard).</li> <li>• Water containing glycol: water/glycol mixture up to 50 %.</li> <li>• Water hardness: 0 to 21°f .</li> </ul>
Liquid temperature	<ul style="list-style-type: none"> <li>• Minimum: -10 °C.</li> <li>• Maximum: 95 °C (pumps with composite housings).</li> <li>110 °C (pumps with cast iron or stainless steel housings).</li> </ul>
Drinking water approvals (ACS, WRAS, DM 174)	Pumps with stainless steel housing are compliant.
Maximum operating pressure (PN)	1 MPa (10 bar).
Minimum inlet pressure/liquid temperature	0,005 MPa (0,05 bar) / 50 °C. 0,030 MPa (0,3 bar) / 95 °C. 0,100 MPa (1 bar) / 110 °C.
Flow estimation	Information available for PWM version only.
Maximum number of starts	3 starts per hour (in any case < 20 starts in the 24 h).
Anti-lock sequence	Continuously restarting every 5 seconds with increasing torque steps till maximum torque. If the rotor unlocks, the pump goes back to its normal operation. If the locked rotor condition persists, the anti-lock sequence is repeated as long as the pump is powered on. If the standby operating mode is selected during the anti-lock sequence, the sequence is reset and the pump goes to standby mode.
Dry run ability	Dry run operation allowed for 24 h.
Reaction time - power on	< 2,8 second.
Reaction time - standby	< 2,3 second.
Sound pressure level	$\leq$ 43 dB(A)

## eco2 INSTALLATION

eco2 is designed for indoor installations.

The pump must be installed with the pump head in a horizontal position, in vertical as well as horizontal pipes. The arrow of the pump housing shows the flow direction through the pump. The pump head can be rotated so the display is in a convenient position. Pipes and valves must be correctly sized.

Do not insulate the motor housing, the electronics can overheat so that the pump automatically switch off.

To ensure adequate cooling of the pump head, position the circulator in such a way that sufficient cooling is ensured. Air temperature must not exceed +55°C.

The local regulations in force overrule specified requirements listed here below.

- The electrical leads are protected from high temperature, vibrations and collisions.
- Use cables according to rules with 3 leads (2 + earth/ground). All cables must be heat-resistant up to +85°C. Cables should be positioned so that they do not touch the motor housing or pipework.
- The current type and voltage of mains connection must correspond to the data plate on the pump.
- Always connect the external protection conductor to ground (earth) terminal before making other electrical connections. All electrical equipment must be ground (earth) connected. This applies to the pump unit and related equipment.
- The power supply line is provided with: a high-sensitivity differential switch (30 mA) (residual current device RCD) suitable for earth fault currents with DC or pulsating DC content (a Type B RCD is suggested).



## CONTROL BOX POSITION

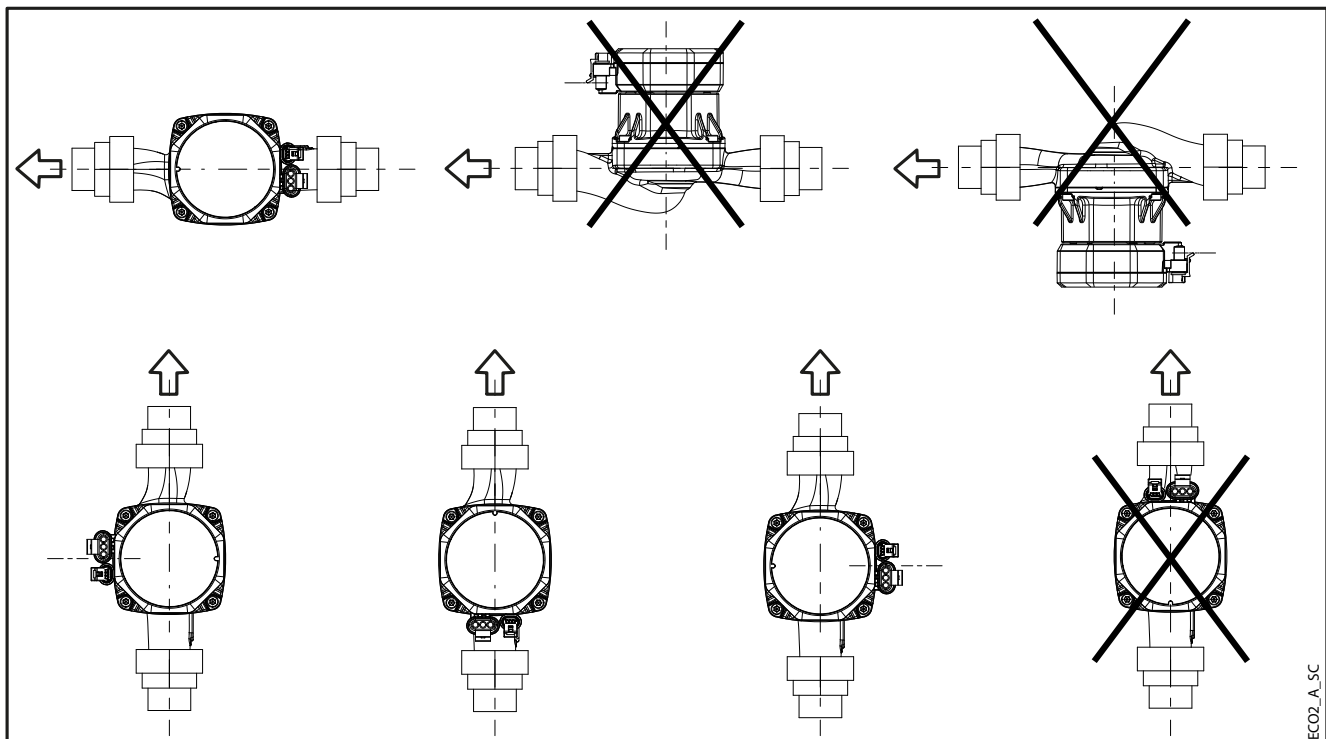

**eco2**  
**EXPLODED VIEW AND MAIN COMPONENTS**

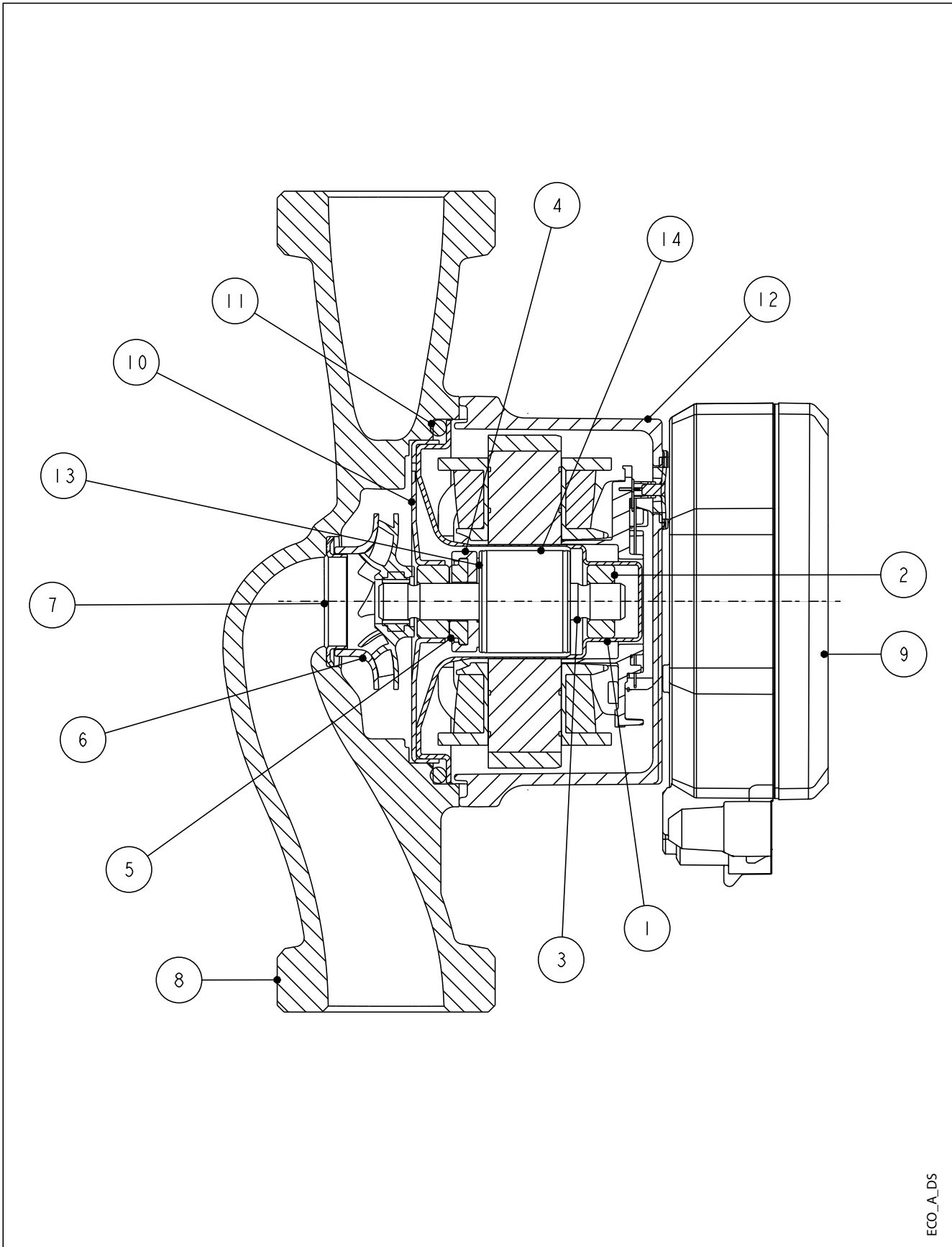

ECO\_A\_DS

**eco2**  
**TABLE OF MATERIALS**











Ref. N.	Denomination	Material	Reference Standards	
			Europe	U.S.A.
1	Rotor can	Stainless steel	EN 1.4435	AISI 316L
2	Bush bearing	Alumina ceramic		
3	Shaft	Alumina ceramic		
4	Thrust bearing housing	EPDM		
5	Thrust bearing	Graphite		
6	Impeller	PPE/PS-I Composite		
7	Wear ring	Stainless steel	EN 1.4301	AISI 304
8	Pump body	Stainless steel	EN 1.4308	AISI 304
		Cast iron	EN-GJL-200	ASTM Class 25
		PA 6 + 30% GF Composite		
9	Control box	PC composite		
10	Front bearing housing	Stainless steel	EN 1.4301	AISI 304
11	O-ring	EPDM		
12	Motor housing	Aluminum	EN-AB-AISI11Cu2	-
13	Rotor plastic	PPS Composite		
14	Rotor sleeve	Stainless steel	EN 1.4301	AISI 304

en\_revA

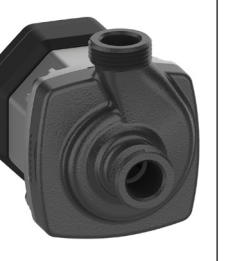

**eco2  
PUMP HOUSING**

The eco2 circulators are available with a wide range of standard integrated housings or custom pump housings with different sizes and different materials.

		Pump size				
		15-130	25-130	25-180	32-180	End suction
Version	Cast iron					
	Stainless steel					
	Composite					

en\_revA

eco2 and eco2 PWMH models are offered with all pump body sizes.

eco2 SOLAR, eco2 SOLAR PWMS and eco2 MICROFLOW PWMM models are exclusively available with the following cast iron pump housing sizes: 15-130, 25-130, 25-180.

Pump housings made of stainless steel are suitable for use with drinking water up to 85°C.

## eco2 CONNECTIONS

eco2 series is available with two different type of connections for the power supply and also for the PWM communication. Either with pre-assembled cables through a cable gland or with Superseal plugs.

On the cable gland models the power cable and the PWM cable, if applicable, will be 2 m long with free wire ends.

The Superseal models have in all cases the Superseal body for power and the Mini Superseal for PWM connection. In the models without PWM control the Mini Superseal plug is a dummy without electrical connectivity. It is supplied with inside ribs for poka-yoke reasons as shown by the following figures.

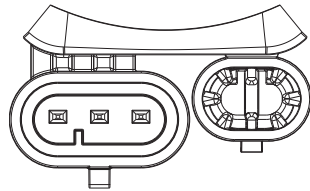

**CONTROL BY KNOB**

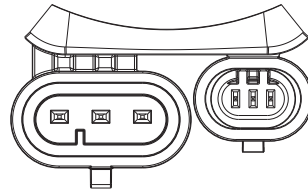

**CONTROL BY PWM**

We do not offer the cables.

eco2 series can be supplied with the below type of connections:

Series name	Connection Type
eco2, eco2 SOLAR	1 or 3
eco2 PWMH, eco2 SOLAR PWMS, eco2 MICROFLOW PWMM	2 or 4

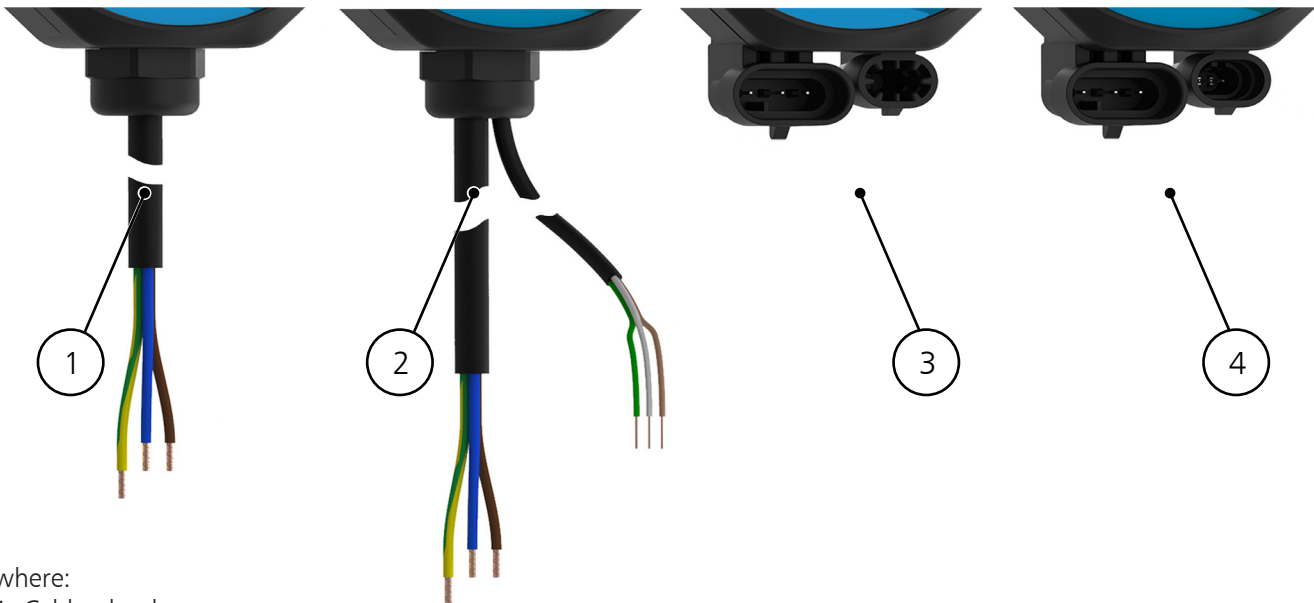

where:

1. Cable gland power
2. Cable gland power + cable gland communication
3. Superseal plug power
4. Superseal plug power + Mini Superseal plug communication

## eco2 .. 4/(N) SERIES DIMENSIONS AND TECHNICAL DATA

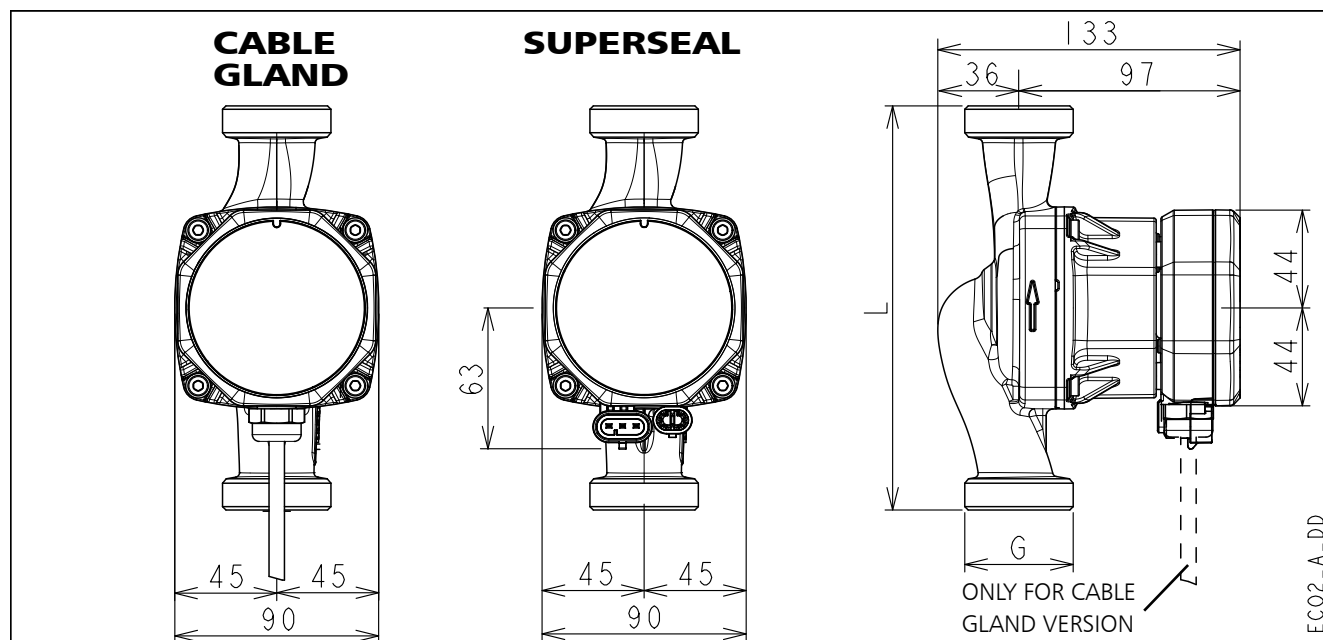

Models	L [mm]	G
eco2 15-4/130 (N) CG	130	G 1 / R 1/2
eco2 25-4/130 (N) CG	130	G 1 1/2 / R 1
eco2 25-4/180 (N) CG	180	G 1 1/2 / R 1
eco2 32-4/180 (N) CG	180	G 2 / R 1 1/4
eco2 15-4/130 (N) TS	130	G 1 / R 1/2
eco2 25-4/130 (N) TS	130	G 1 1/2 / R 1
eco2 25-4/180 (N) TS	180	G 1 1/2 / R 1
eco2 32-4/180 (N) TS	180	G 2 / R 1 1/4
eco2 PWMH 15-4/130 (N) CG	130	G 1 / R 1/2
eco2 PWMH 25-4/130 (N) CG	130	G 1 1/2 / R 1
eco2 PWMH 25-4/180 (N) CG	180	G 1 1/2 / R 1
eco2 PWMH 32-4/180 (N) CG	180	G 2 / R 1 1/4
eco2 PWMH 15-4/130 (N) TS	130	G 1 / R 1/2
eco2 PWMH 25-4/130 (N) TS	130	G 1 1/2 / R 1
eco2 PWMH 25-4/180 (N) TS	180	G 1 1/2 / R 1
eco2 PWMH 32-4/180 (N) TS	180	G 2 / R 1 1/4

En-Rev\_A

Technical Data	
Rated voltage	1 x 230 V ±10%
Frequency	50/60 Hz
Power absorbed [W] (min/max)	3,3 / 24 PWM: 1,2 / 24
Input current [A] (min/max)	0,03 / 0,21 PWM: 0,01 / 0,21
Stand-by power [W]	< 1
Specific EEI ≤	0,16
IP protection	44
Insulation class	155 (F)
Max. working pressure	1,0 MPa (10 bar)
Liquid temperature	-10°C to +110 °C
Sound pressure level	≤ 43 dB(A)
Port nominal diameter	DN15, DN25, DN32
Port to port	130 mm, 180 mm
Pump body material	Cast Iron, Stainless steel

En-Rev\_B

**eco2 .. 4/(N) SERIES  
PERFORMANCE CURVES**

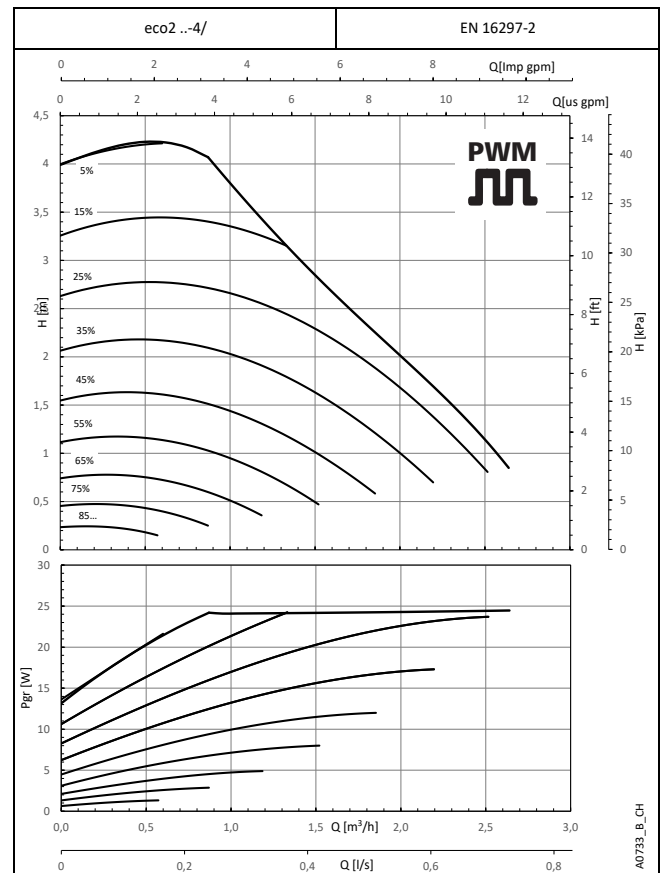
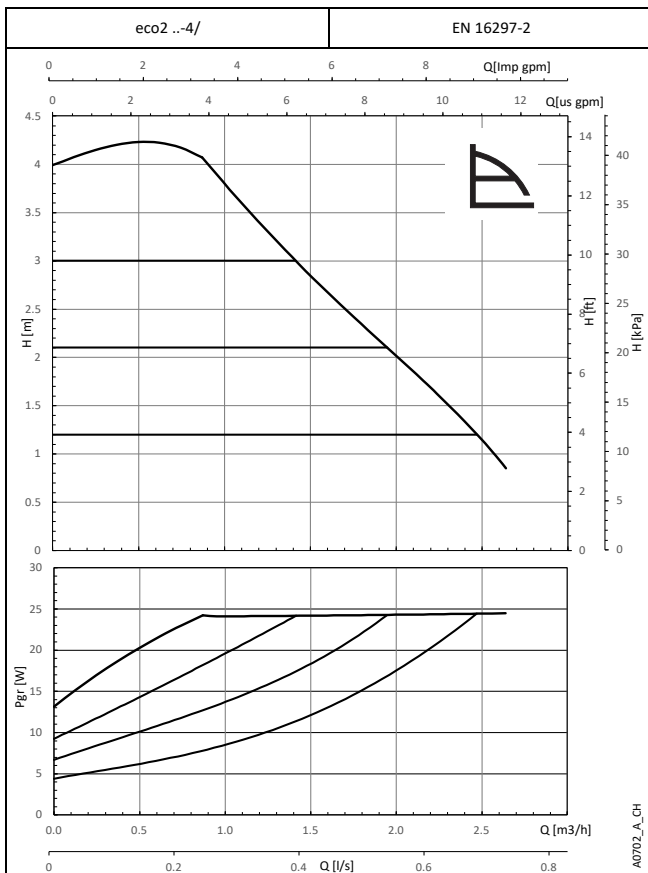
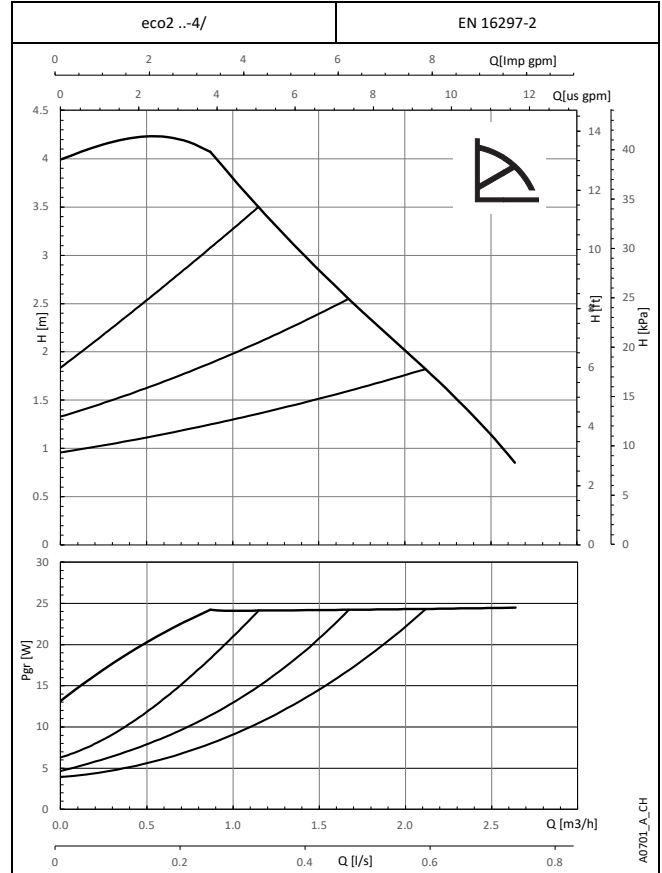
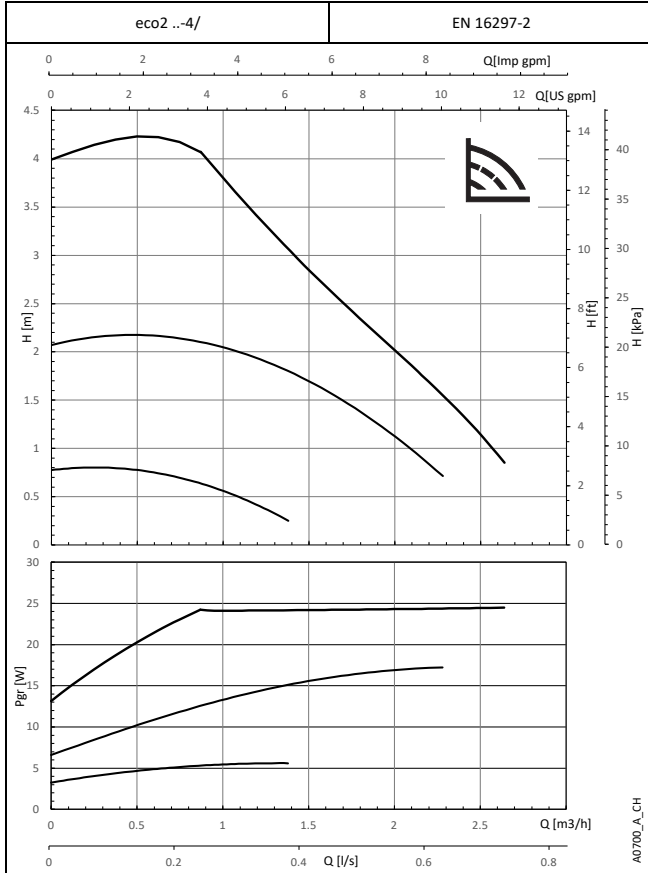

These performances are valid for liquids with density  $\rho = 1.0 \text{ Kg/dm}^3$  and kinematic viscosity  $\nu = 1 \text{ mm}^2/\text{sec}$ .  
Pump operates steplessly. Lines correspond to knob settings and are for reference only.

## eco2 .. 6/(N) SERIES DIMENSIONS AND TECHNICAL DATA

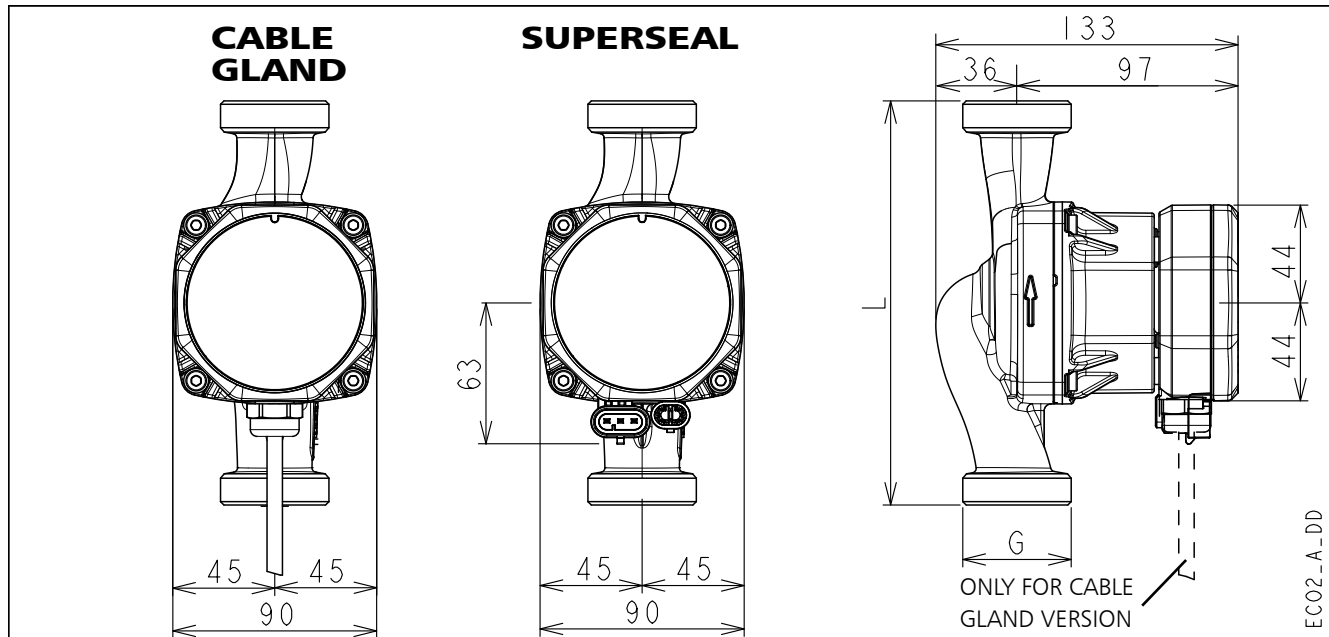

Models	L [mm]	G
eco2 15-6/130 (N) CG	130	G 1 / R 1/2
eco2 25-6/130 (N) CG	130	G 1 1/2 / R 1
eco2 25-6/180 (N) CG	180	G 1 1/2 / R 1
eco2 32-6/180 (N) CG	180	G 2 / R 1 1/4
eco2 15-6/130 (N) TS	130	G 1 / R 1/2
eco2 25-6/130 (N) TS	130	G 1 1/2 / R 1
eco2 25-6/180 (N) TS	180	G 1 1/2 / R 1
eco2 32-6/180 (N) TS	180	G 2 / R 1 1/4
eco2 PWMH 15-6/130 (N) CG	130	G 1 / R 1/2
eco2 PWMH 25-6/130 (N) CG	130	G 1 1/2 / R 1
eco2 PWMH 25-6/180 (N) CG	180	G 1 1/2 / R 1
eco2 PWMH 32-6/180 (N) CG	180	G 2 / R 1 1/4
eco2 PWMH 15-6/130 (N) TS	130	G 1 / R 1/2
eco2 PWMH 25-6/130 (N) TS	130	G 1 1/2 / R 1
eco2 PWMH 25-6/180 (N) TS	180	G 1 1/2 / R 1
eco2 PWMH 32-6/180 (N) TS	180	G 2 / R 1 1/4
eco2M PWMM 15-6/130 CG	130	G 1 / R 1/2
eco2M PWMM 25-6/130 CG	130	G 1 1/2 / R 1
eco2M PWMM 25-6/180 CG	180	G 1 1/2 / R 1
eco2M PWMM 15-6/130 TS	130	G 1 / R 1/2
eco2M PWMM 25-6/130 TS	130	G 1 1/2 / R 1
eco2M PWMM 25-6/180 TS	180	G 1 1/2 / R 1

En-Rev\_A

Technical Data	
Rated voltage	1 x 230 V ±10%
Frequency	50/60 Hz
Power absorbed [W] (min/max)	3,3 / 34 PWM: 1,2 / 34
Input current [A] (min/max)	0,03 / 0,29 PWM: 0,01 / 0,29
Stand-by power [W]	< 1
IP protection	44
Insulation class	155 (F)
Max. working pressure	1,0 MPa (10 bar)
Liquid temperature	-10°C to +110 °C
Sound pressure level	≤ 43 dB(A)
Port nominal diameter	DN15, DN25, DN32
Port to port	130 mm, 180 mm
Pump body material	Cast Iron, Stainless steel

En-Rev\_B

**eco2 .. 6/(N) SERIES  
PERFORMANCE CURVES**

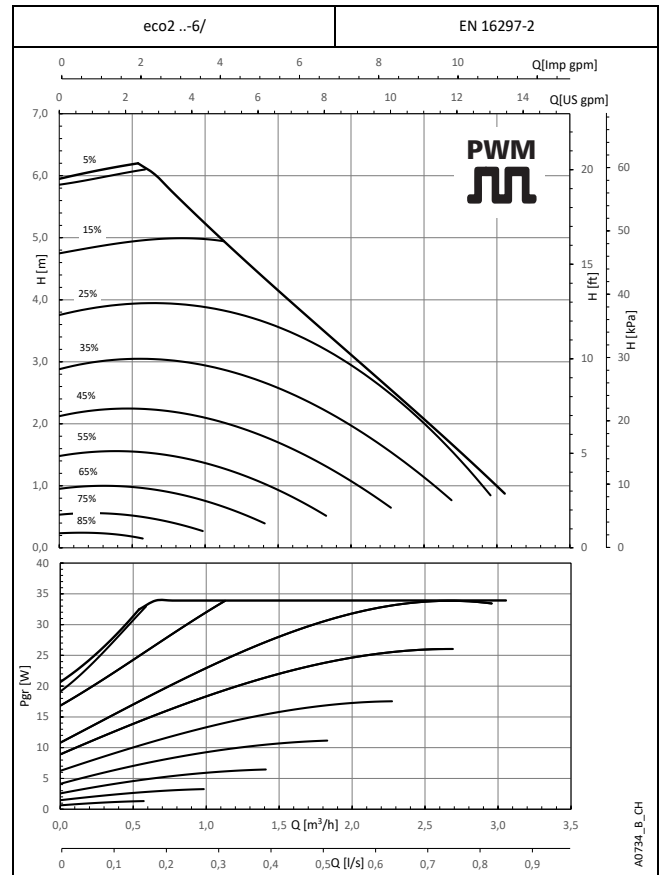
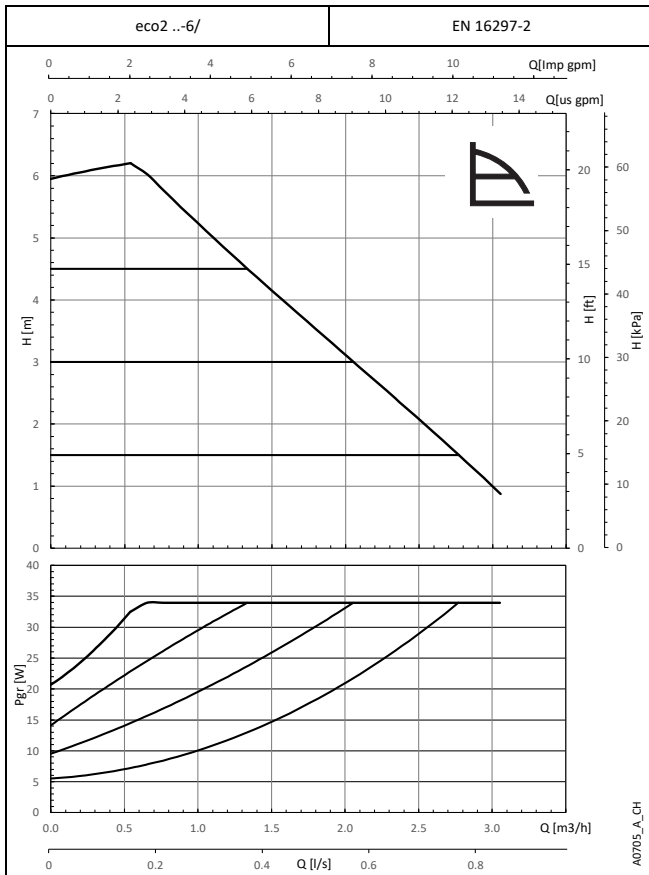
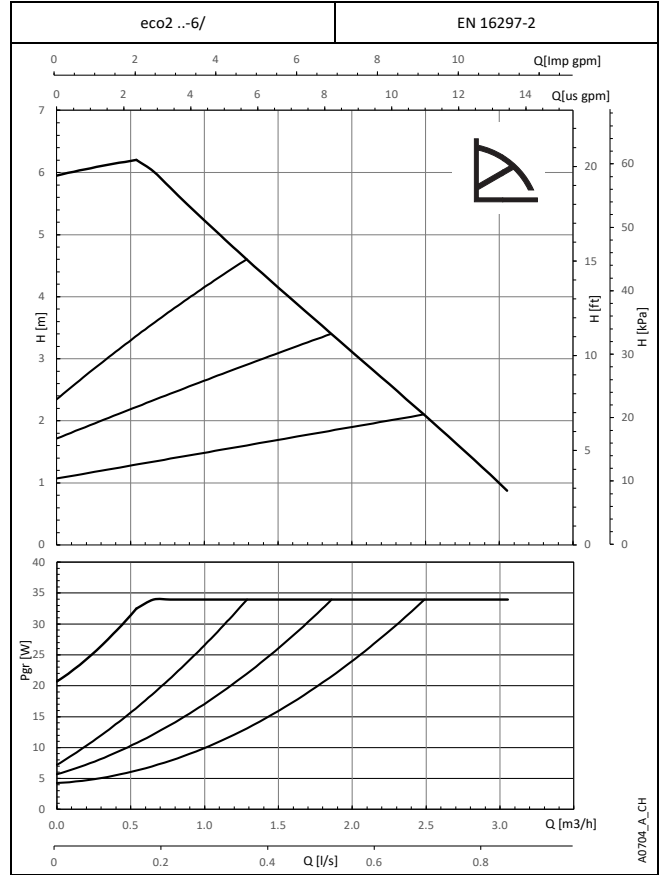
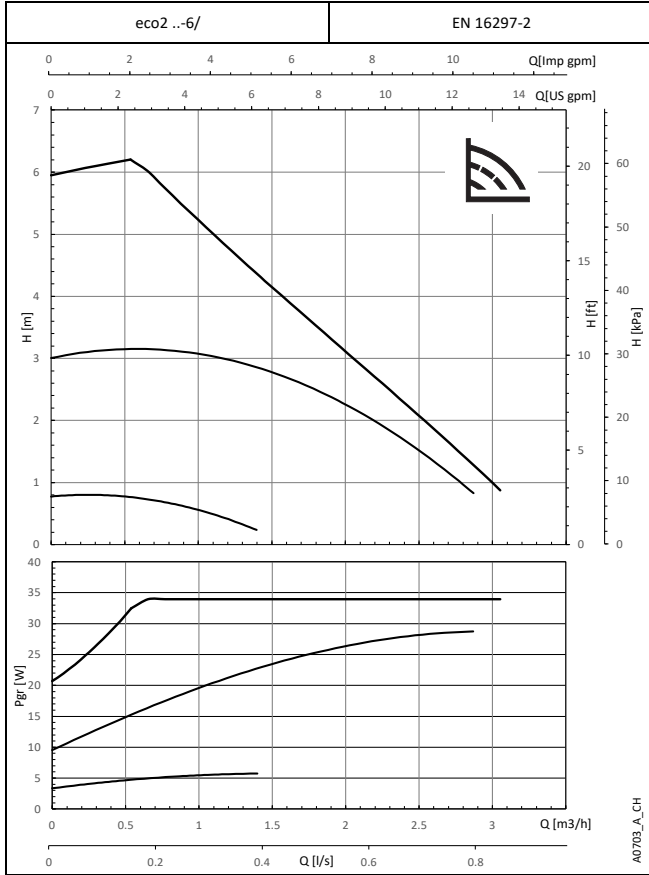

These performances are valid for liquids with density  $\rho = 1.0 \text{ Kg/dm}^3$  and kinematic viscosity  $\nu = 1 \text{ mm}^2/\text{sec}$ .  
Pump operates steplessly. Lines correspond to knob settings and are for reference only.

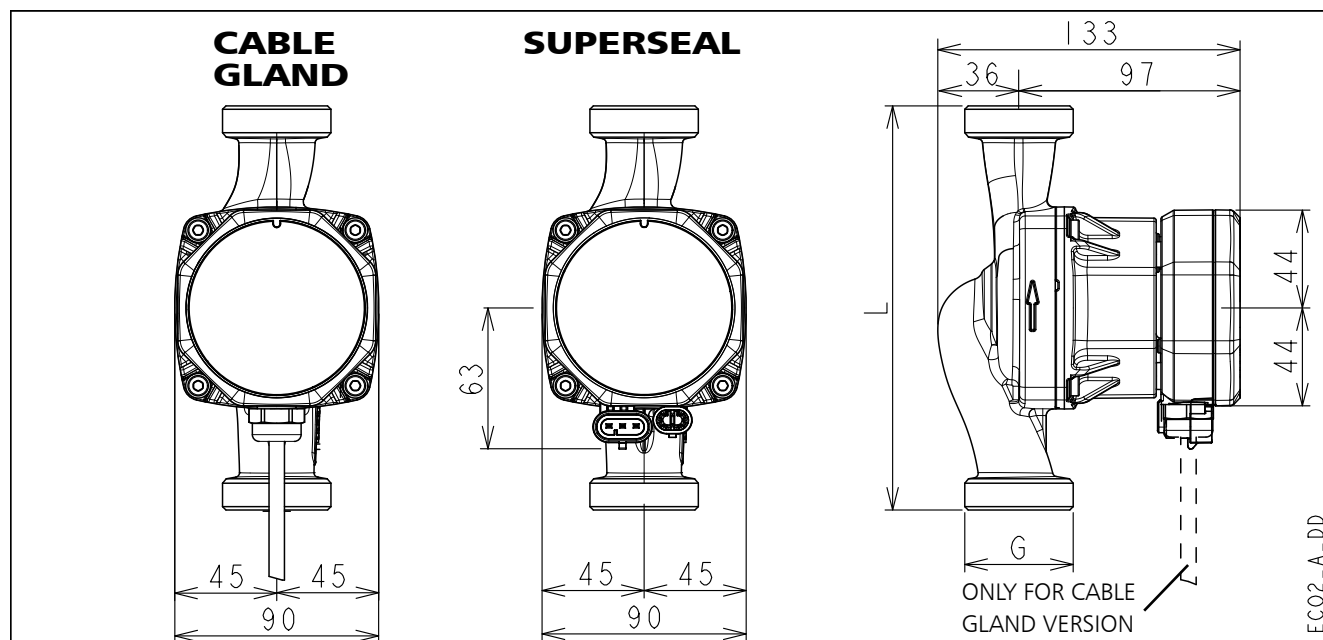
**eco2 .. 8/(N) SERIES**  
**DIMENSIONS AND TECHNICAL DATA**

Models	L [mm]	G
eco2 15-8/130 (N) CG	130	G 1 / R 1/2
eco2 25-8/130 (N) CG	130	G 1 1/2 / R 1
eco2 25-8/180 (N) CG	180	G 1 1/2 / R 1
eco2 32-8/180 (N) CG	180	G 2 / R 1 1/4
eco2 15-8/130 (N) TS	130	G 1 / R 1/2
eco2 25-8/130 (N) TS	130	G 1 1/2 / R 1
eco2 25-8/180 (N) TS	180	G 1 1/2 / R 1
eco2 32-8/180 (N) TS	180	G 2 / R 1 1/4
eco2 PWMH 15-8/130 (N) CG	130	G 1 / R 1/2
eco2 PWMH 25-8/130 (N) CG	130	G 1 1/2 / R 1
eco2 PWMH 25-8/180 (N) CG	180	G 1 1/2 / R 1
eco2 PWMH 32-8/180 (N) CG	180	G 2 / R 1 1/4
eco2 PWMH 15-8/130 (N) TS	130	G 1 / R 1/2
eco2 PWMH 25-8/130 (N) TS	130	G 1 1/2 / R 1
eco2 PWMH 25-8/180 (N) TS	180	G 1 1/2 / R 1
eco2 PWMH 32-8/180 (N) TS	180	G 2 / R 1 1/4
eco2M PWMM 15-8/130 CG	130	G 1 / R 1/2
eco2M PWMM 25-8/130 CG	130	G 1 1/2 / R 1
eco2M PWMM 25-8/180 CG	180	G 1 1/2 / R 1
eco2M PWMM 15-8/130 TS	130	G 1 / R 1/2
eco2M PWMM 25-8/130 TS	130	G 1 1/2 / R 1
eco2M PWMM 25-8/180 TS	180	G 1 1/2 / R 1

En-Rev\_A

Technical Data	
Rated voltage	1 x 230 V ±10%
Frequency	50/60 Hz
Power absorbed [W] (min/max)	4,7 / 55
	PWM: 1,2 / 55
Input current [A] (min/max)	0,05 / 0,45
	PWM: 0,01 / 0,45
Stand-by power [W]	< 1
Specific EEI ≤	0,18
IP protection	44
Insulation class	155 (F)
Max. working pressure	1,0 MPa (10 bar)
Liquid temperature	-10°C to +110 °C
Sound pressure level	≤ 43 dB(A)
Port nominal diameter	DN15, DN25, DN32
Port to port	130 mm, 180 mm
Pump body material	Cast Iron, Stainless steel

En-Rev\_B

**eco2 .. 8/(N) SERIES  
PERFORMANCE CURVES**

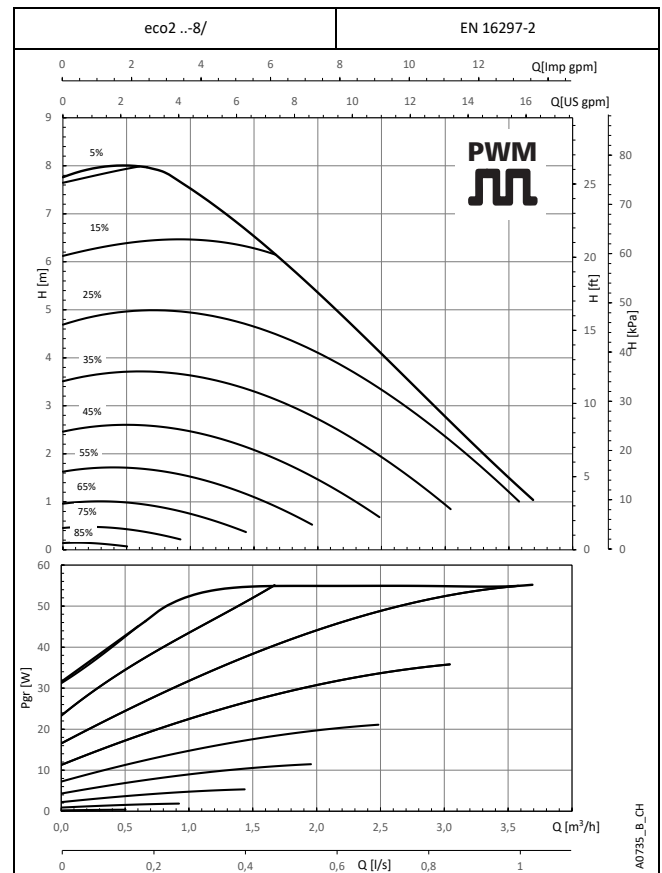
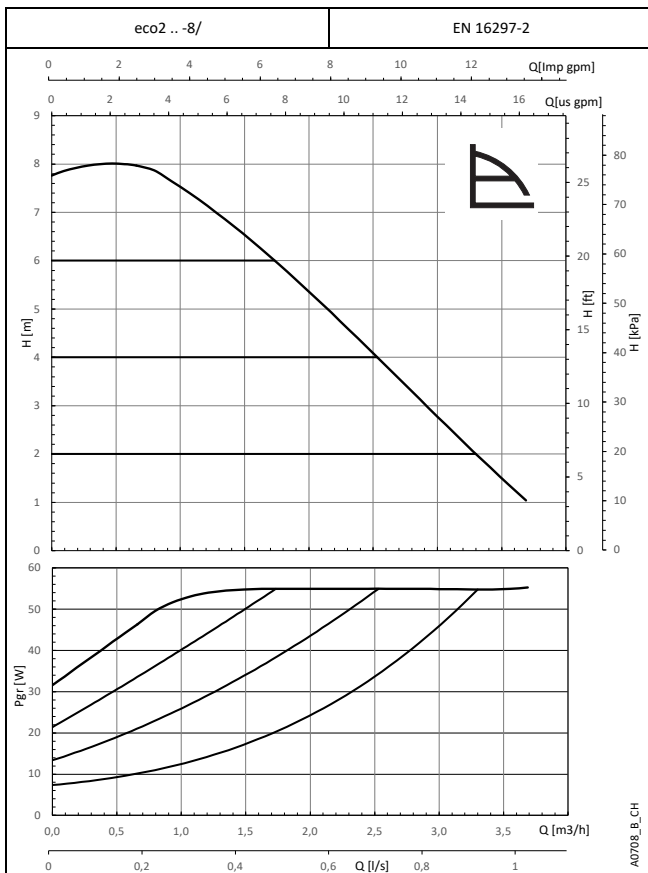
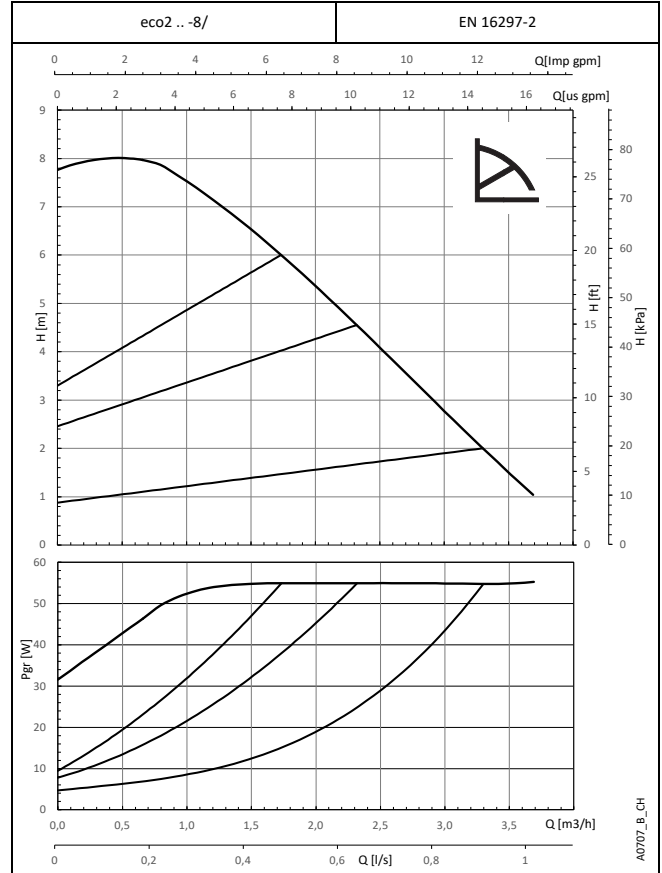
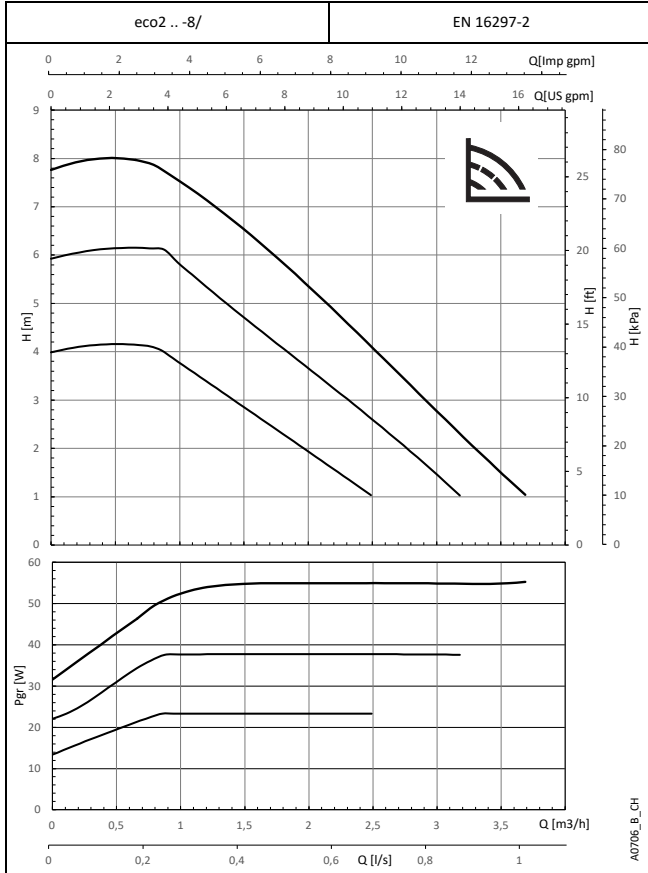

These performances are valid for liquids with density  $\rho = 1.0 \text{ Kg/dm}^3$  and kinematic viscosity  $\nu = 1 \text{ mm}^2/\text{sec}$ .  
Pump operates steplessly. Lines correspond to knob settings and are for reference only.

## eco2 15-6/END SERIES DIMENSIONS AND TECHNICAL DATA

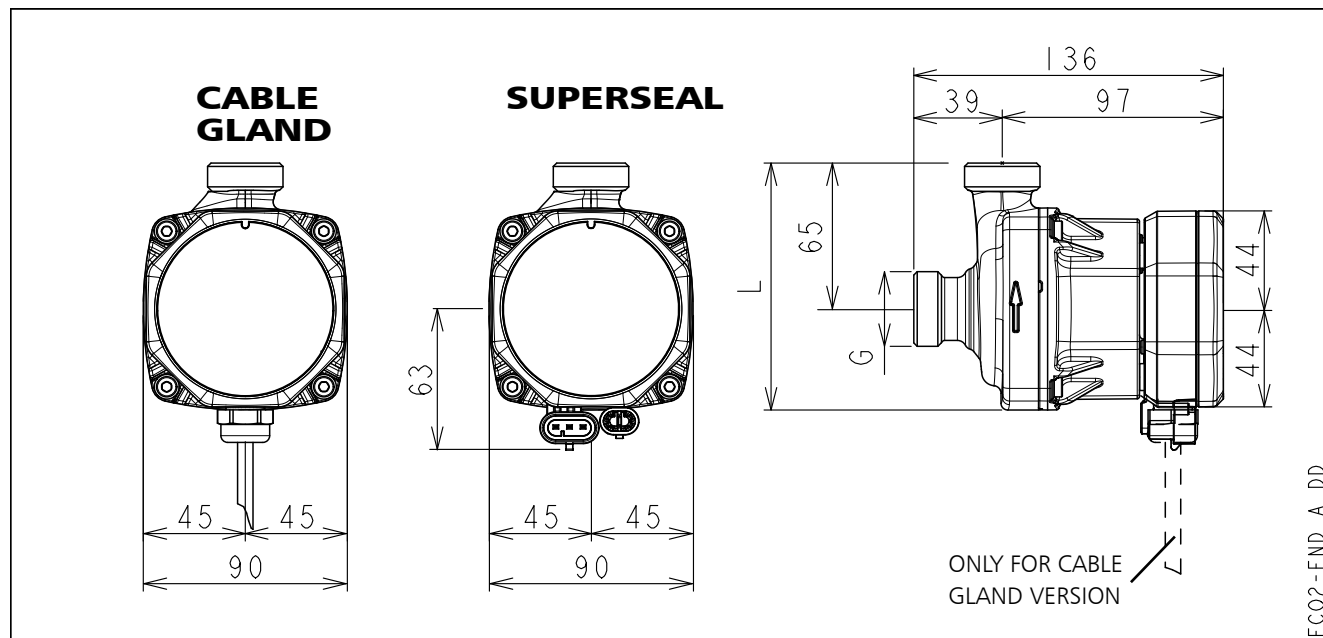

Models	L [mm]	G
eco2 15-6/END CG	110	G 1 / R 1/2
eco2 15-6/END TS	110	G 1 / R 1/2

En-Rev\_A

Technical Data	
Rated voltage	1 x 230 V ±10%
Frequency	50/60 Hz
Power absorbed [W] (min/max)	3,5 / 34
Input current [A] (min/max)	0,03 / 0,29
Stand-by power [W]	< 1
Specific EEI ≤	0,17
IP protection	44
Insulation class	155 (F)
Max. working pressure	1,0 MPa (10 bar)
Liquid temperature	-10°C to +110 °C
Sound pressure level	≤ 43 dB(A)
Port nominal diameter	DN15
Port to port	End suction version
Pump body material	Cast iron

En-Rev\_B

**eco2 15-6/END SERIES  
PERFORMANCE CURVES**

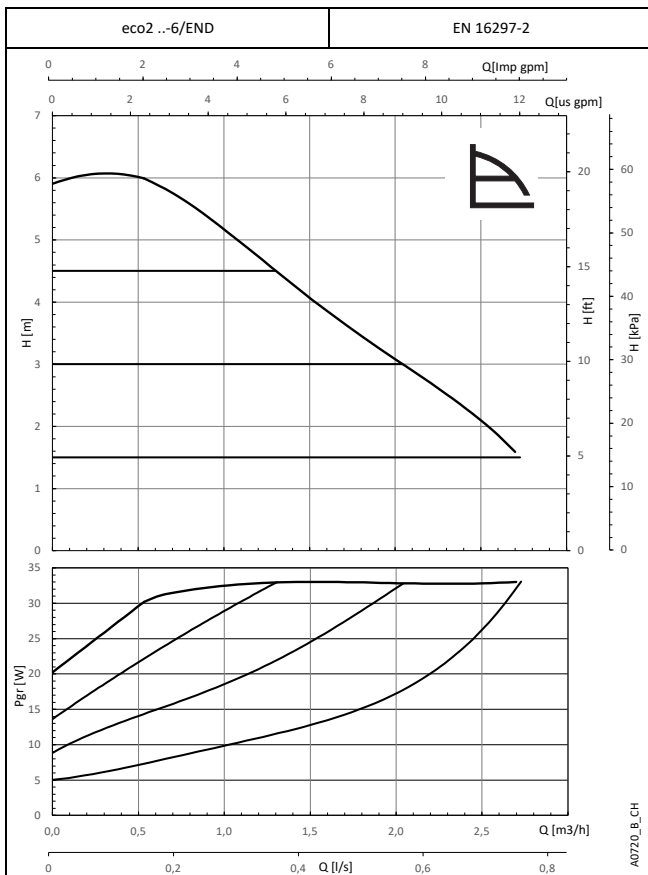
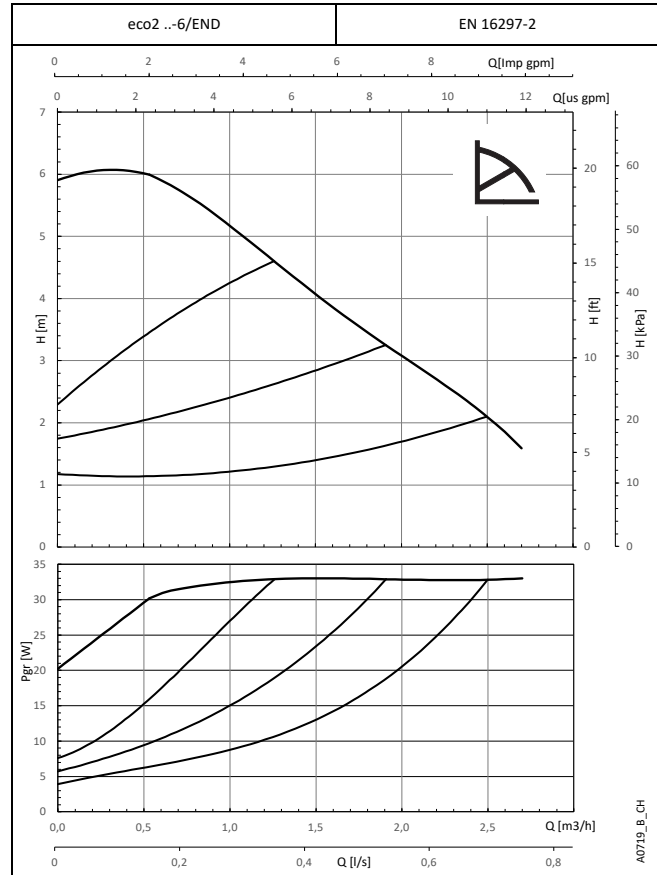
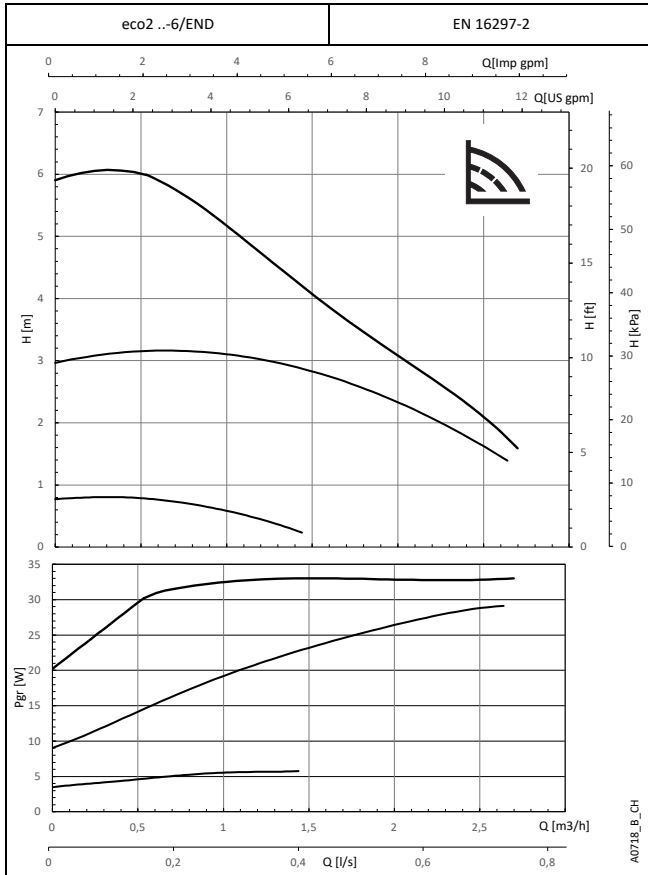

These performances are valid for liquids with density  $\rho = 1.0 \text{ Kg/dm}^3$  and kinematic viscosity  $\nu = 1 \text{ mm}^2/\text{sec}$ .  
Pump operates steplessly. Lines correspond to knob settings and are for reference only.

**eco2 15-8/END SERIES  
DIMENSIONS AND TECHNICAL DATA**

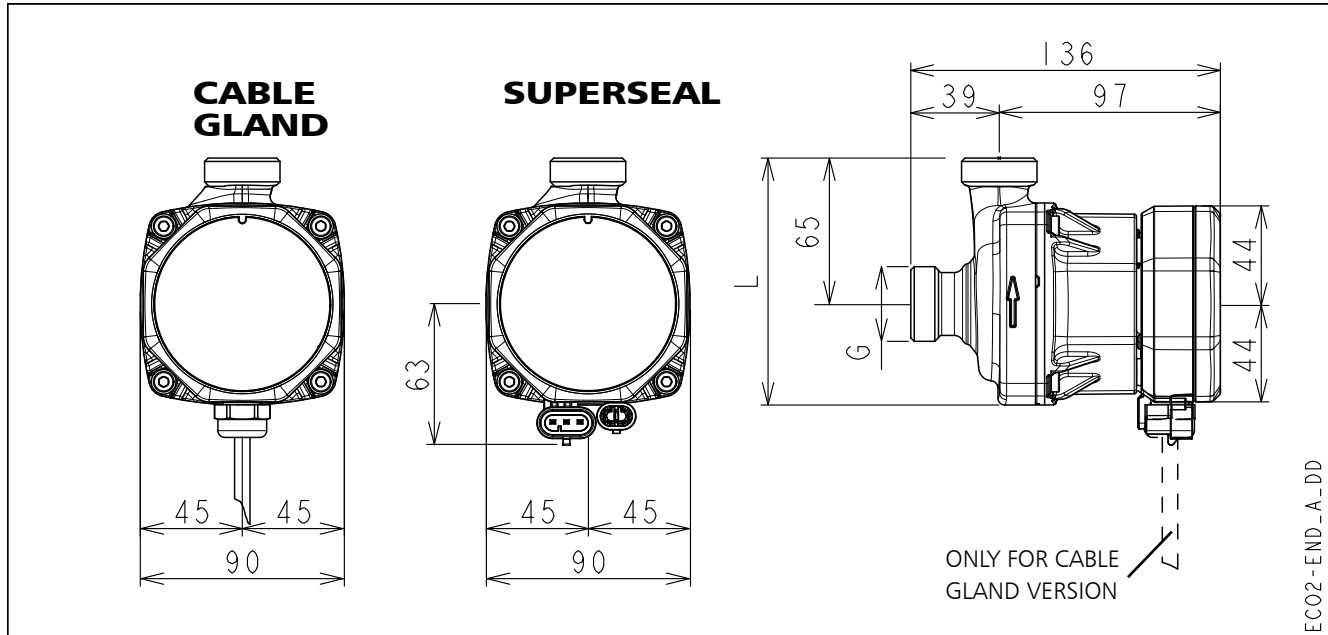

Models	L [mm]	G
eco2 15-8/END CG	110	G 1 / R 1/2
eco2 15-8/END TS	110	G 1 / R 1/2

En-Rev\_A

Technical Data	
Rated voltage	1 x 230 V ± 10%
Frequency	50/60 Hz
Power absorbed [W] (min/max)	4,7 / 55
Input current [A] (min/max)	0,05 / 0,45
Stand-by power [W]	< 1
Specific EEI ≤	0,18
IP protection	44
Insulation class	155 (F)
Max. working pressure	1,0 MPa (10 bar)
Liquid temperature	-10°C to +110 °C
Sound pressure level	≤ 43 dB(A)
Port nominal diameter	DN15
Port to port	End suction version
Pump body material	Cast Iron

En-Rev\_B

**eco2 15-8/END SERIES  
PERFORMANCE CURVES**

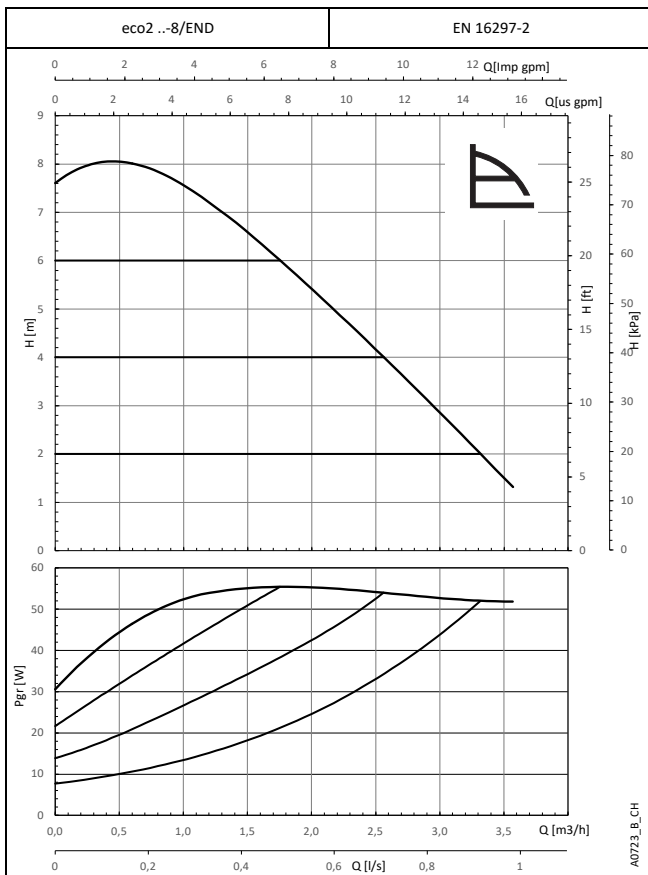
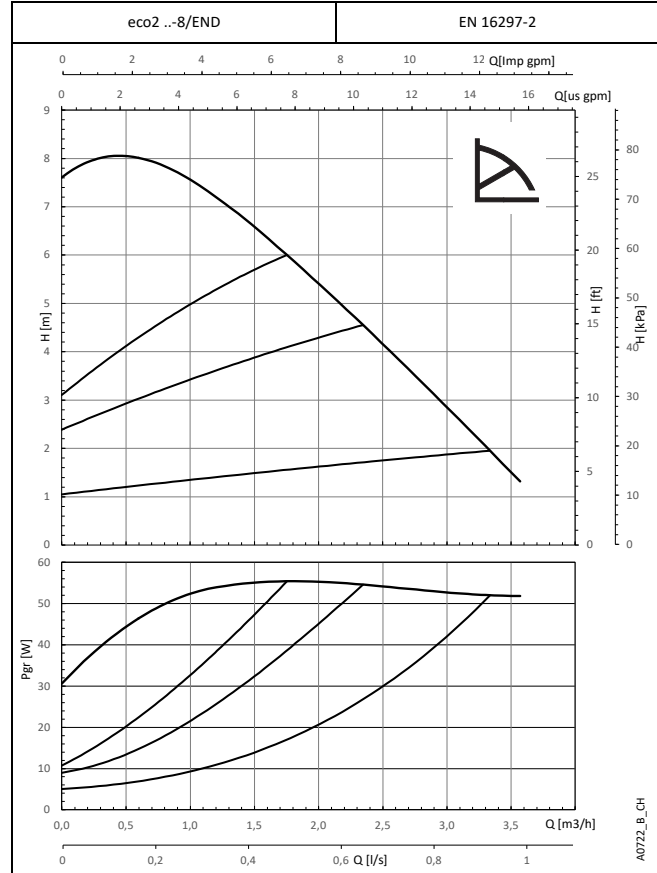
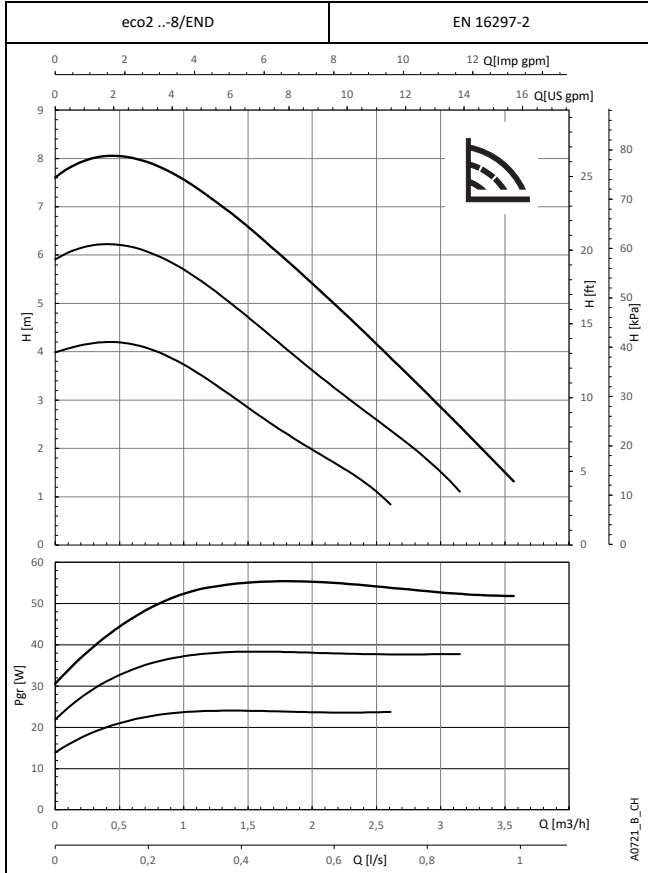

These performances are valid for liquids with density  $\rho = 1.0 \text{ Kg/dm}^3$  and kinematic viscosity  $\nu = 1 \text{ mm}^2/\text{sec}$ .  
Pump operates steplessly. Lines correspond to knob settings and are for reference only.

## eco2 ..-4/130 C SERIES DIMENSIONS AND TECHNICAL DATA

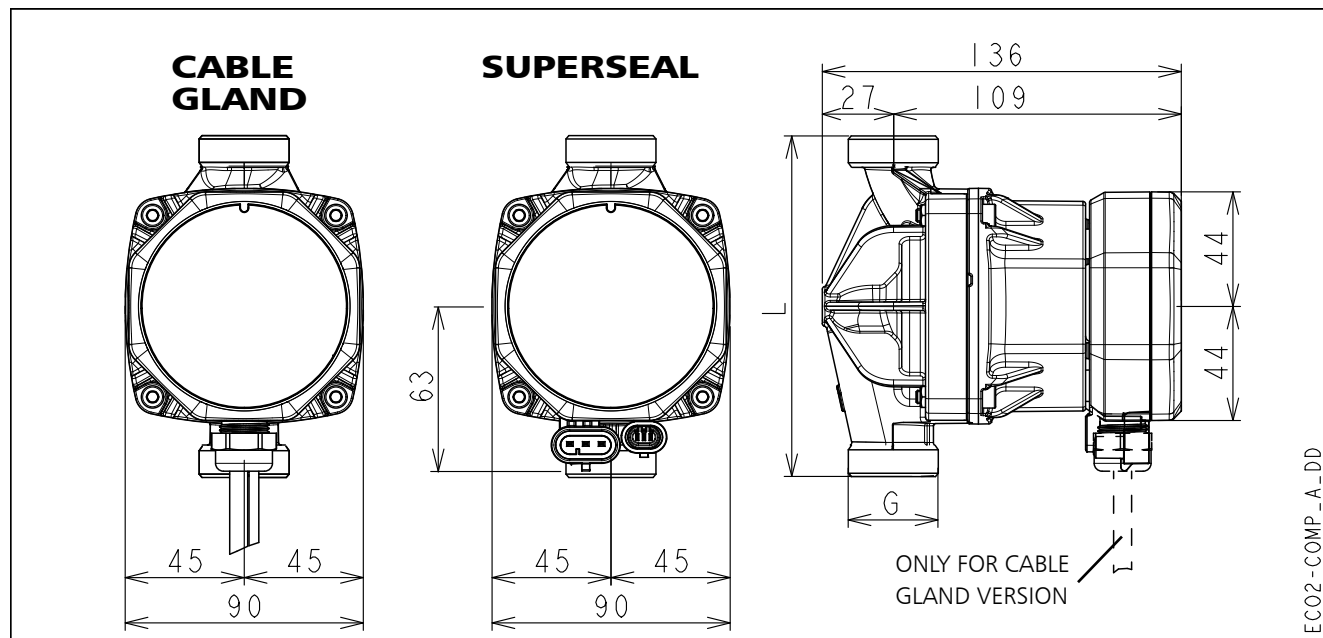

Models	L [mm]	G
eco2 15-4/130C CG	130	G 1 / R 1/2
eco2 15-4/130C TS	130	G 1 / R 1/2
eco2 PWMH 15-4/130C CG	130	G 1 / R 1/2
eco2 PWMH 15-4/130C TS	130	G 1 / R 1/2

En-Rev\_B

Technical Data	
Rated voltage	1 x 230 V ±10%
Frequency	50/60 Hz
Power absorbed [W] (min/max)	3,6 / 24 PWM: 1,2 / 24
Input current [A] (min/max)	0,04 / 0,21 PWM: 0,01 / 0,21
Stand-by power [W]	< 1
Specific EEI ≤	0,18
IP protection	44
Insulation class	155 (F)
Max. working pressure	1,0 MPa (10 bar)
Liquid temperature	-10°C to +95 °C
Sound pressure level	≤ 43 dB(A)
Port nominal diameter	DN15
Port to port	130 mm
Pump body material	Composite

En-Rev\_B

**eco2 ..-4/130 C SERIES  
PERFORMANCE CURVES**

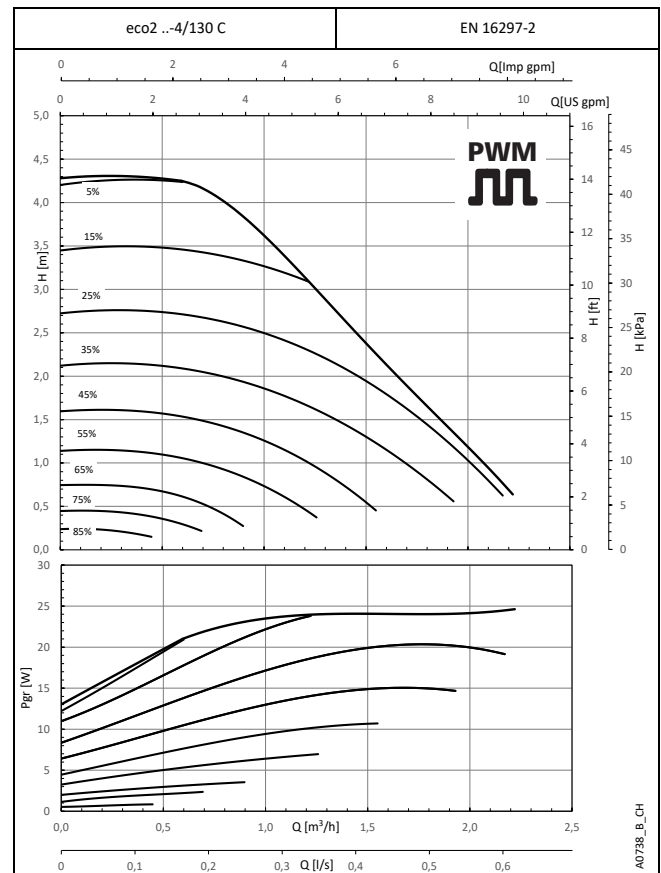
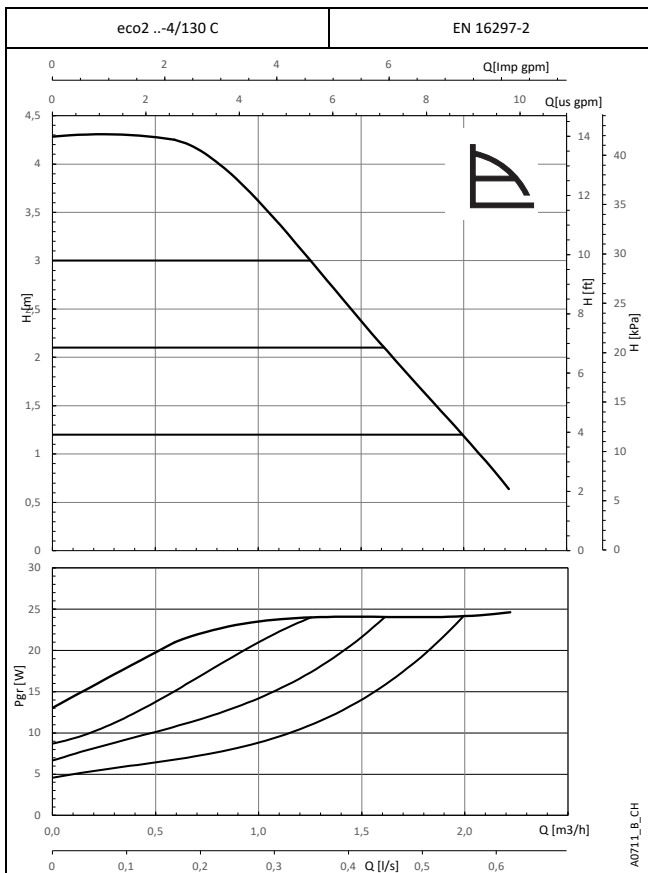
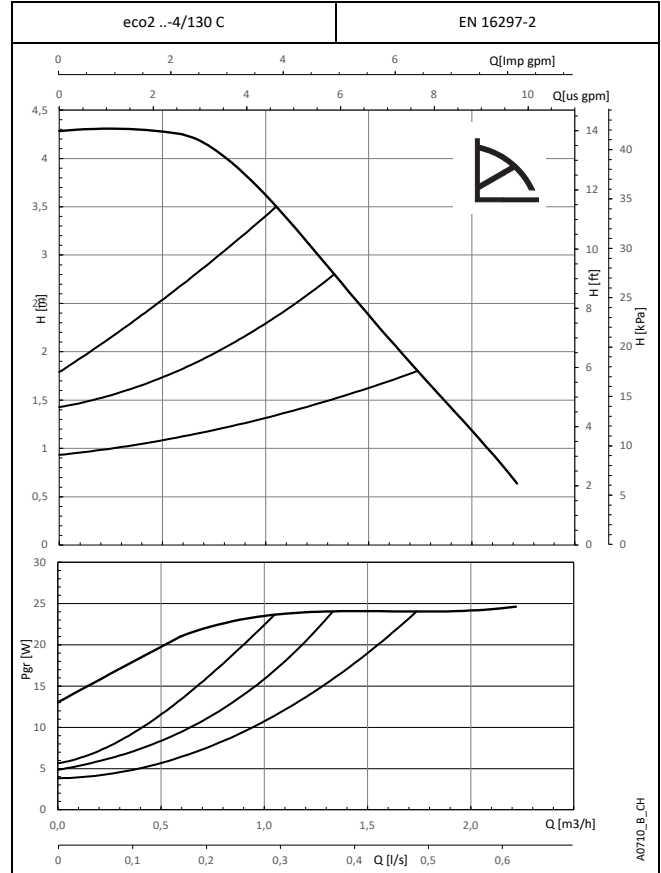
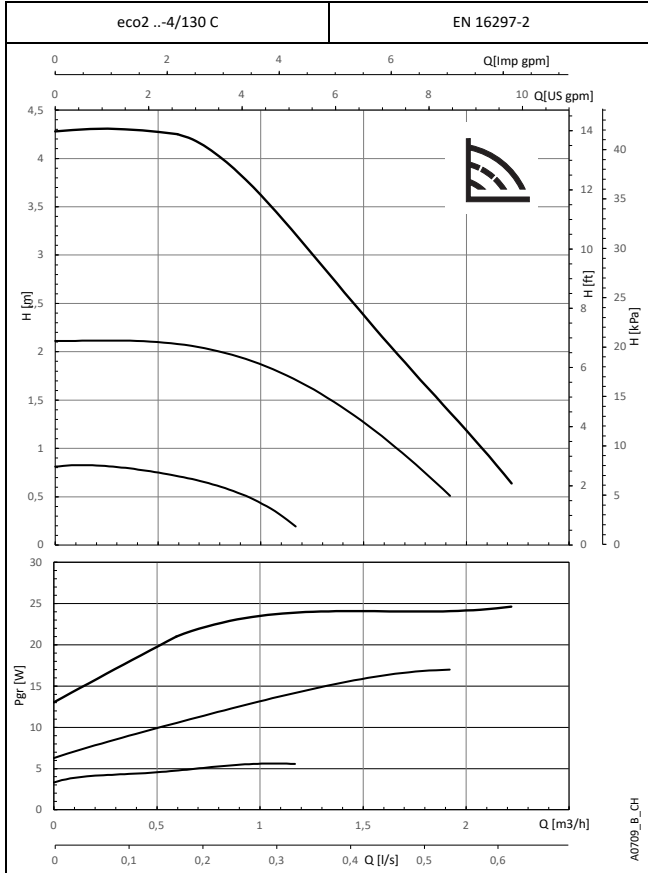

These performances are valid for liquids with density  $\rho = 1.0 \text{ Kg/dm}^3$  and kinematic viscosity  $\nu = 1 \text{ mm}^2/\text{sec}$ .  
Pump operates steplessly. Lines correspond to knob settings and are for reference only.

**eco2 ..-6/130 C SERIES  
DIMENSIONS AND TECHNICAL DATA**

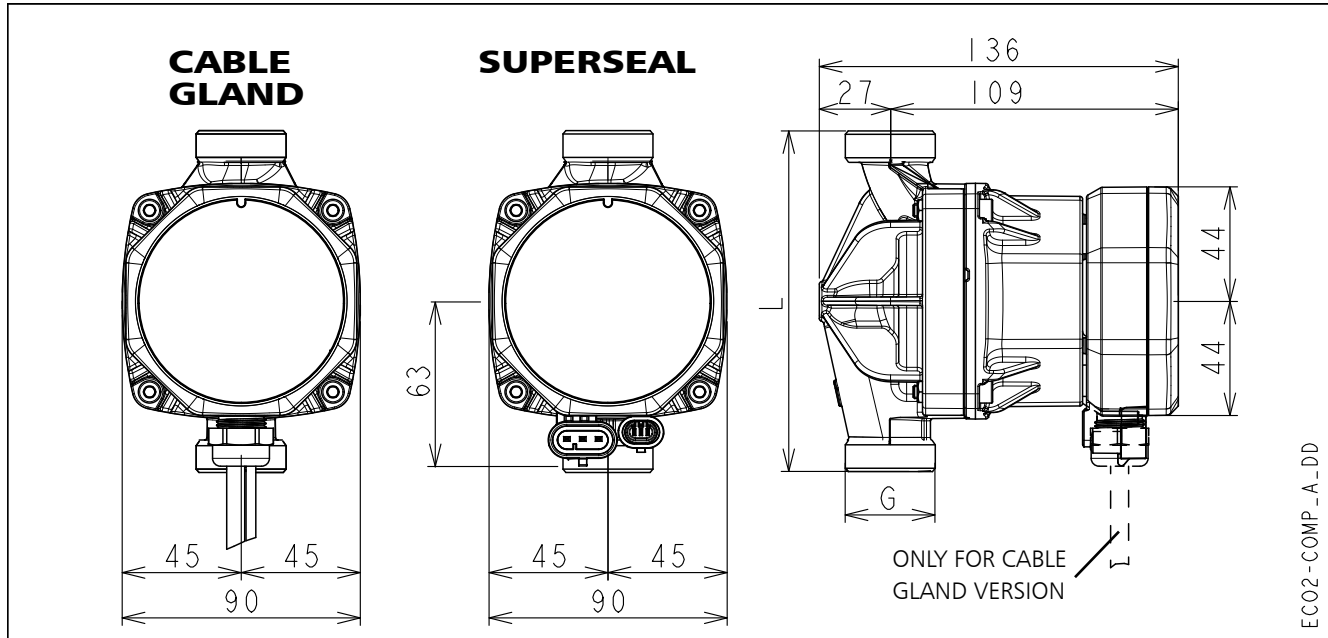

Models	L [mm]	G
eco2 15-6/130C CG	130	G 1 / R 1/2
eco2 15-6/130C TS	130	G 1 / R 1/2
eco2 25-6/130C TS	130	G 1 1/2 / R 1
eco2 PWMH 15-6/130C CG	130	G 1 / R 1/2
eco2 PWMH 15-6/130C TS	130	G 1 / R 1/2
eco2 PWMH 25-6/130C TS	130	G 1 1/2 / R 1

En-Rev\_B

Technical Data	
Rated voltage	1 x 230 V ±10%
Frequency	50/60 Hz
Power absorbed [W] (min/max)	3,6 / 38 PWM: 1,2 / 38
Input current [A] (min/max)	0,04 / 0,32 PWM: 0,01 / 0,32
Stand-by power [W]	< 1
Specific EEI ≤	0,20
IP protection	44
Insulation class	155 (F)
Max. working pressure	1,0 MPa (10 bar)
Liquid temperature	-10°C to +95 °C
Sound pressure level	≤ 43 dB(A)
Port nominal diameter	DN15, DN25
Port to port	130 mm
Pump body material	Composite

En-Rev\_C

**eco2 ..-6/130 C SERIES  
PERFORMANCE CURVES**

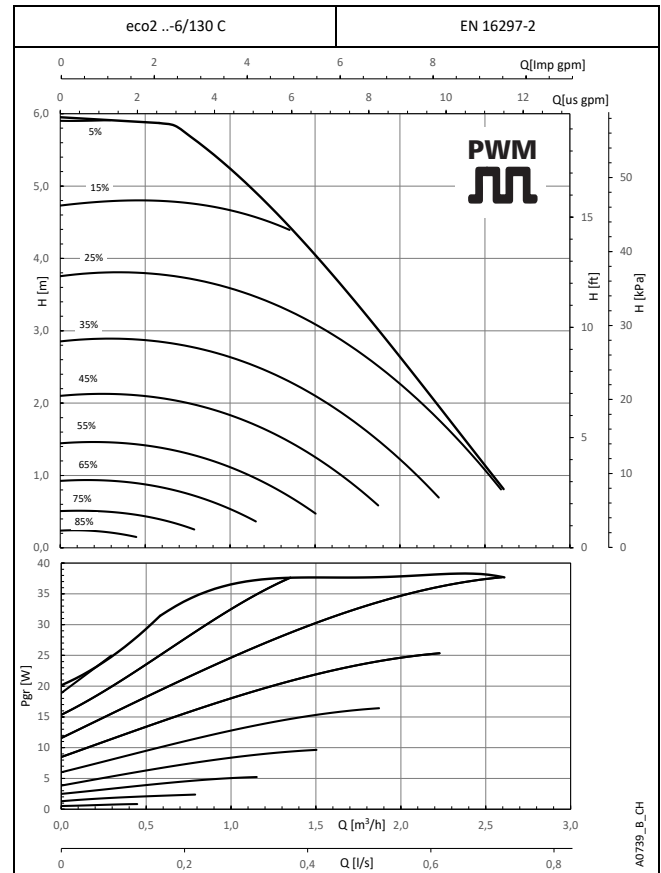
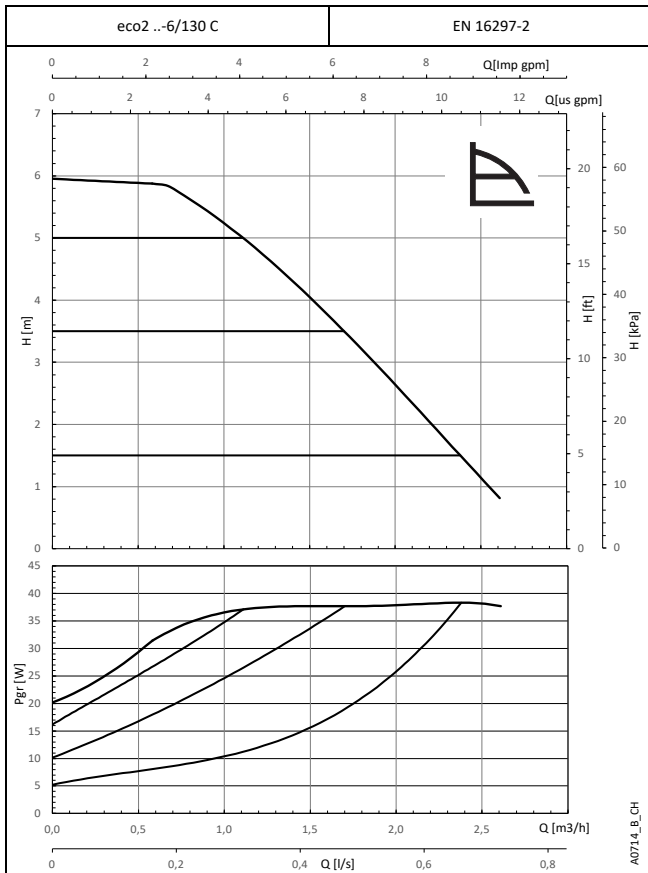
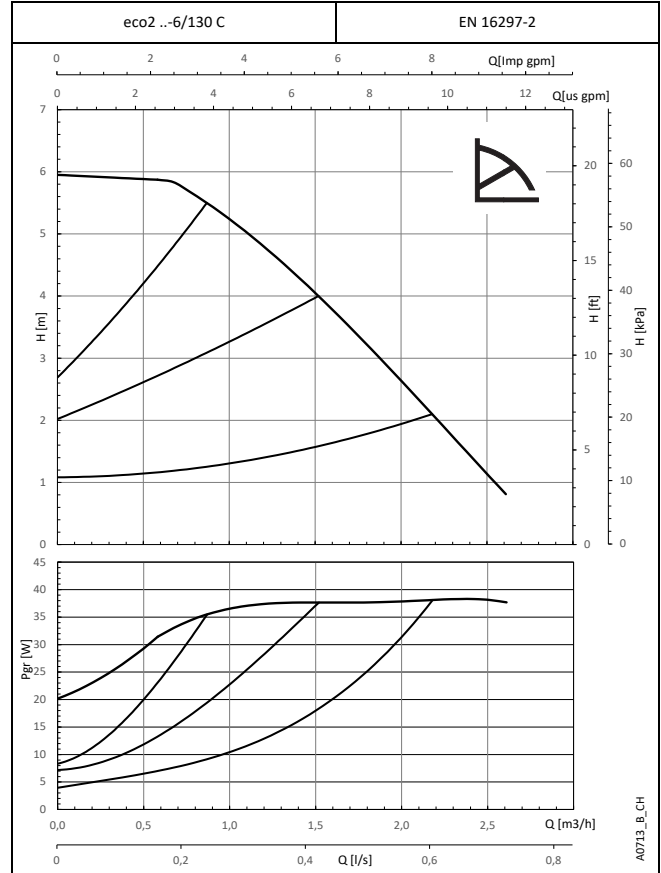
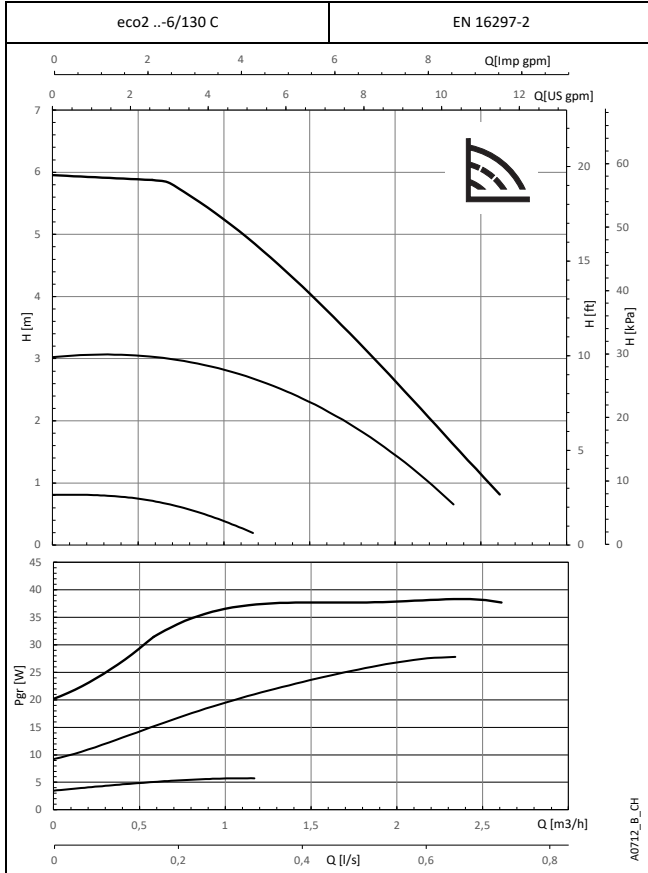

These performances are valid for liquids with density  $\rho = 1.0 \text{ Kg/dm}^3$  and kinematic viscosity  $\nu = 1 \text{ mm}^2/\text{sec}$ .  
Pump operates steplessly. Lines correspond to knob settings and are for reference only.

**eco2 ..-8/130 C SERIES**  
**DIMENSIONS AND TECHNICAL DATA**

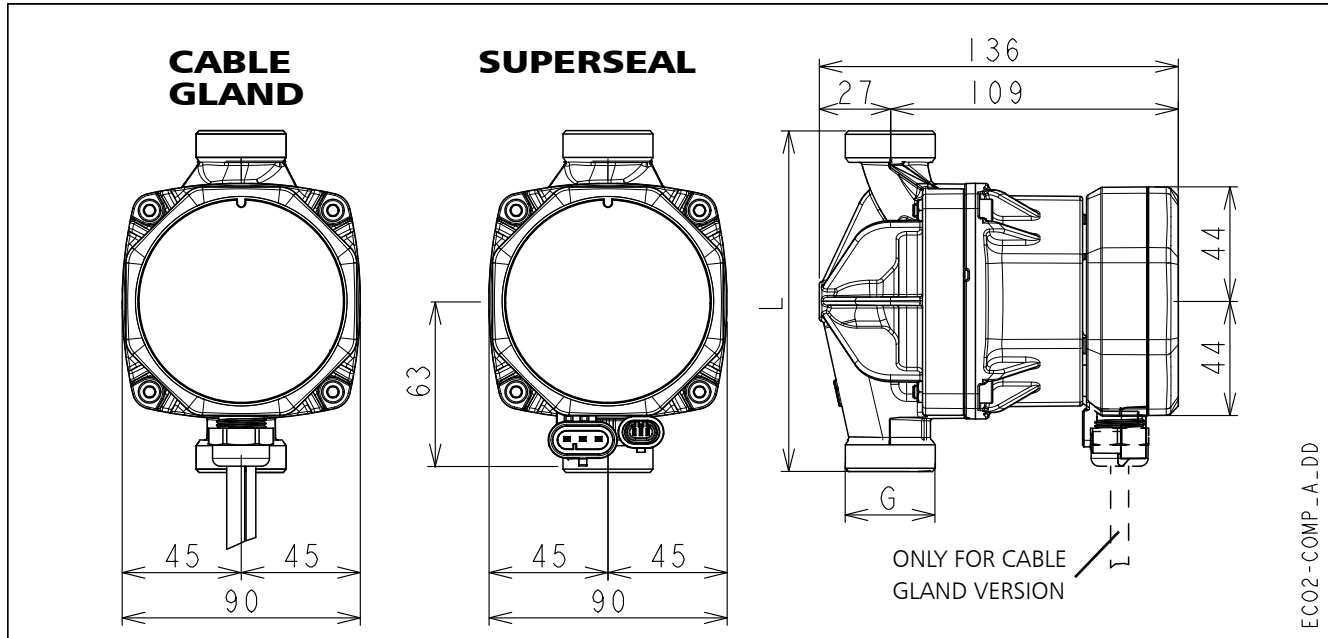

Models	L [mm]	G
eco2 15-8/130C CG	130	G 1 / R 1/2
eco2 15-8/130C TS	130	G 1 / R 1/2
eco2 25-8/130C TS	130	G 1 1/2 / R 1
eco2 PWMH 15-8/130C CG	130	G 1 / R 1/2
eco2 PWMH 15-8/130C TS	130	G 1 / R 1/2
eco2 PWMH 25-8/130C TS	130	G 1 1/2 / R 1

En-Rev\_B

Technical Data	
Rated voltage	1 x 230 V ±10%
Frequency	50/60 Hz
Power absorbed [W] (min/max)	4 / 55 PWM: 1,2 / 55
Input current [A] (min/max)	0,04 / 0,45 PWM: 0,01 / 0,45
Stand-by power [W]	< 1
Specific EEI ≤	0,20
IP protection	44
Insulation class	155 (F)
Max. working pressure	1,0 MPa (10 bar)
Liquid temperature	-10°C to +95 °C
Sound pressure level	≤ 43 dB(A)
Port nominal diameter	DN15, DN25
Port to port	130 mm
Pump body material	Composite

En-Rev\_C

**eco2 ...-8/130 C SERIES  
PERFORMANCE CURVES**

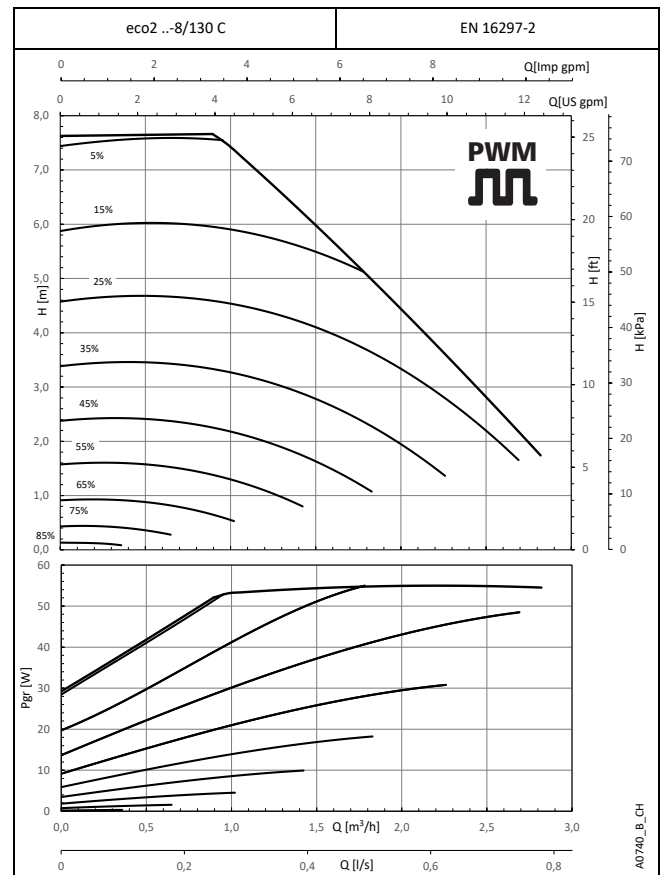
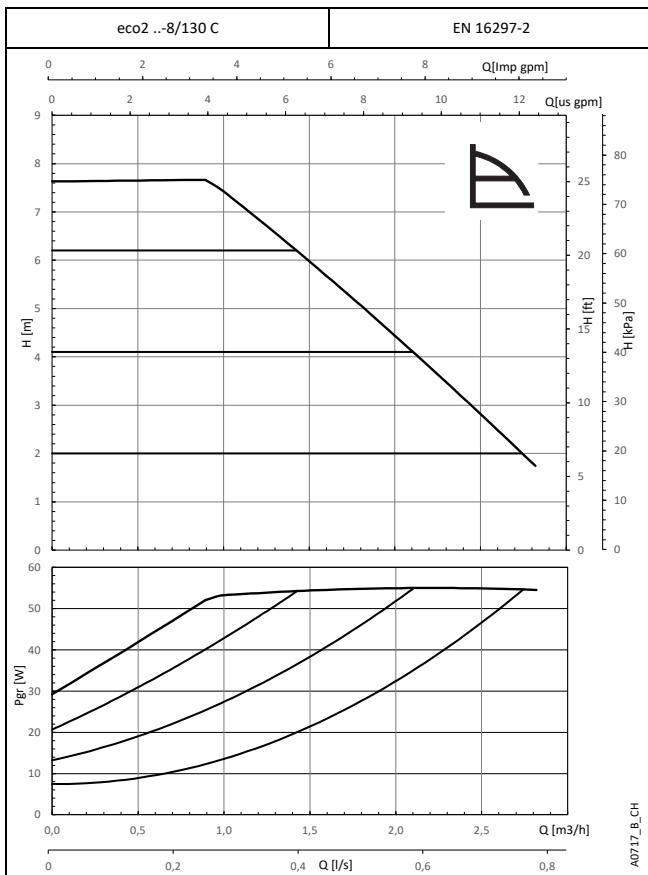
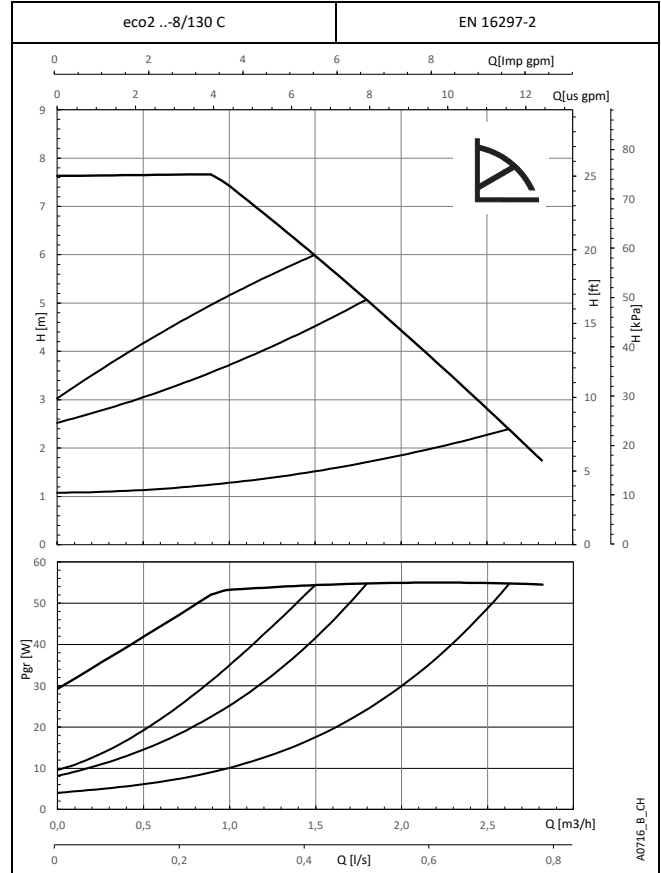
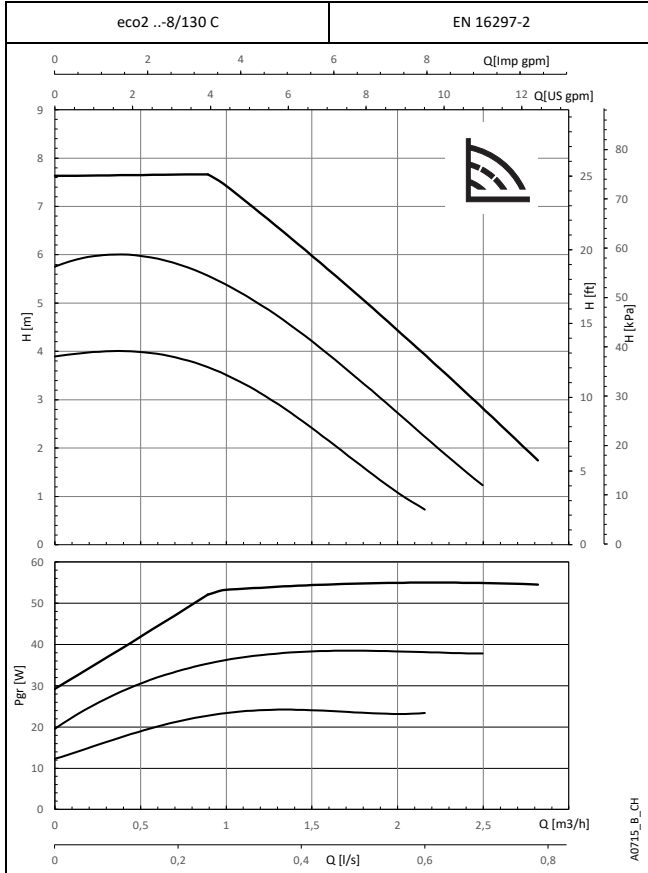

These performances are valid for liquids with density  $\rho = 1.0 \text{ Kg/dm}^3$  and kinematic viscosity  $\nu = 1 \text{ mm}^2/\text{sec}$ .  
Pump operates steplessly. Lines correspond to knob settings and are for reference only.

## eco2S ..-8/ SERIES DIMENSIONS AND TECHNICAL DATA

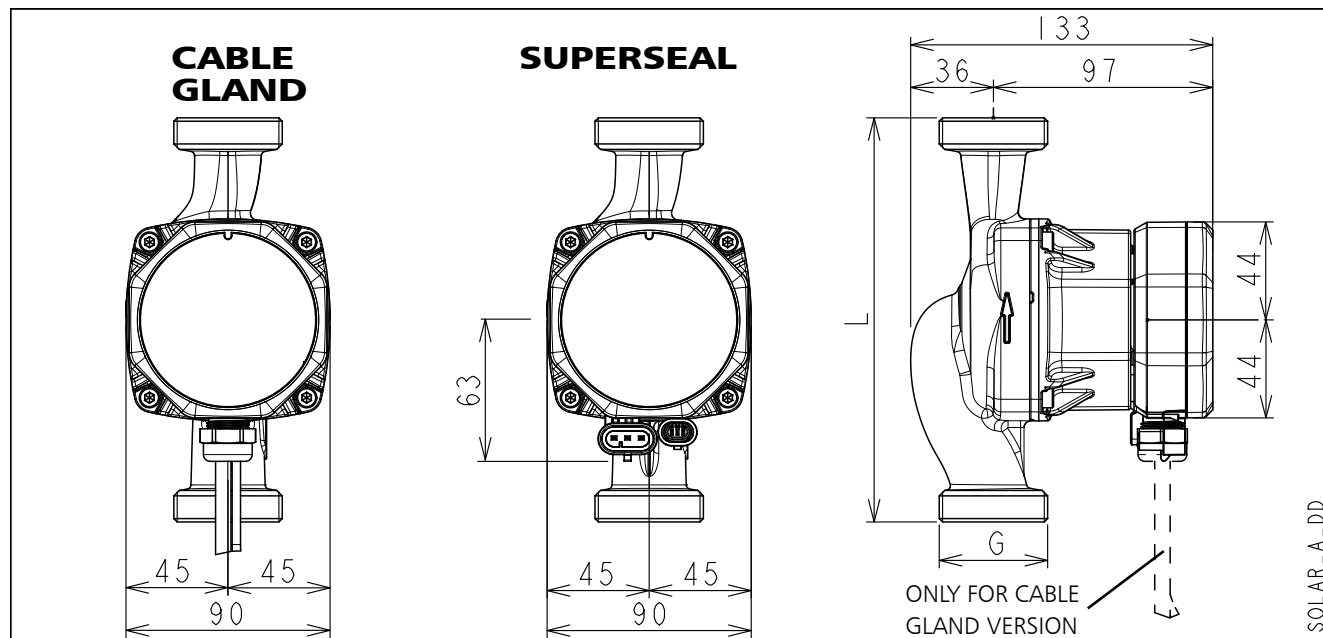

SOLAR\_A\_DD

Models	L [mm]	G
eco2S 15-8/130 CG	130	G 1 / R 1/2
eco2S 25-8/130 CG	130	G 1 1/2 / R 1
eco2S 25-8/180 CG	180	G 1 1/2 / R 1
eco2S 15-8/130 TS	130	G 1 / R 1/2
eco2S 25-8/130 TS	130	G 1 1/2 / R 1
eco2S 25-8/180 TS	180	G 1 1/2 / R 1
eco2S PWMS 15-8/130 CG	130	G 1 / R 1/2
eco2S PWMS 25-8/130 CG	130	G 1 1/2 / R 1
eco2S PWMS 25-8/180 CG	180	G 1 1/2 / R 1
eco2S PWMS 15-8/130 TS	130	G 1 / R 1/2
eco2S PWMS 25-8/130 TS	130	G 1 1/2 / R 1
eco2S PWMS 25-8/180 TS	180	G 1 1/2 / R 1

En-Rev\_A

Technical Data	
Rated voltage	1 x 230 V ±10%
Frequency	50/60 Hz
Power absorbed [W] (min/max)	3,6 / 45
	PWM: 1,8 / 45
Input current [A] (min/max)	0,04 / 0,38
	PWM: 0,02 / 0,38
Stand-by power [W]	< 1
Specific EEI ≤	0,18
IP protection	44
Insulation class	155 (F)
Max. working pressure	1,0 MPa (10 bar)
Liquid temperature	-10°C to +110 °C
Sound pressure level	≤ 43 dB(A)
Port nominal diameter	DN15, DN25
Port to port	130 mm, 180 mm
Pump body material	Cast Iron

En-Rev\_B

**eco2S ..-8/ SERIES  
PERFORMANCE CURVES**

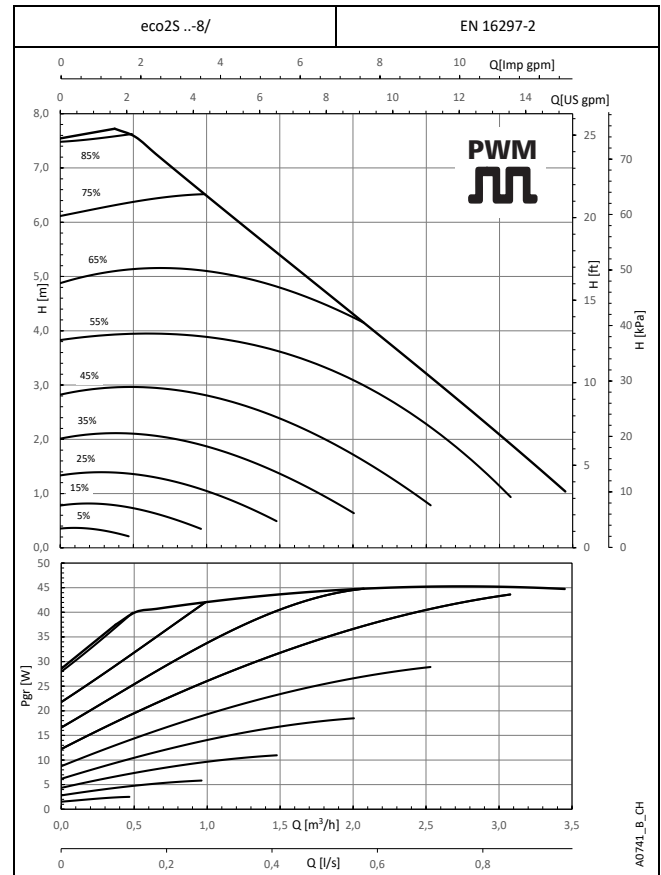
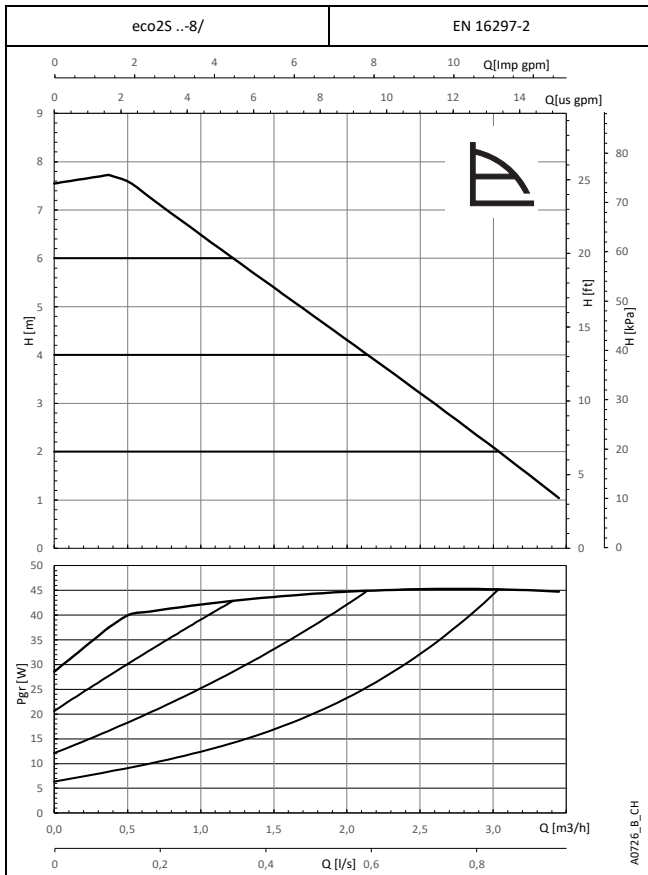
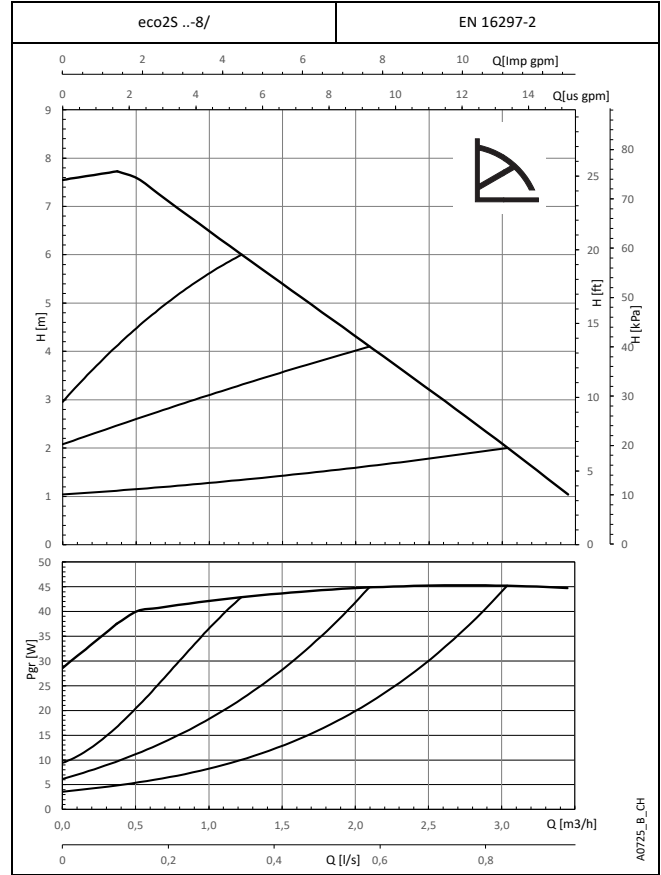
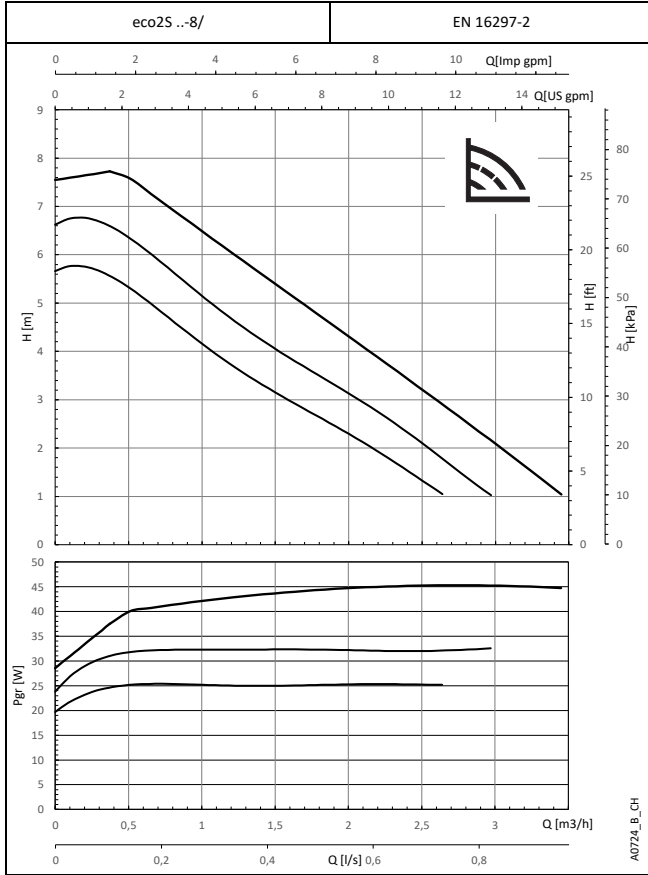

These performances are valid for liquids with density  $\rho = 1.0 \text{ Kg/dm}^3$  and kinematic viscosity  $\nu = 1 \text{ mm}^2/\text{sec}$ .  
Pump operates steplessly. Lines correspond to knob settings and are for reference only.

## eco2S ..-15/ SERIES DIMENSIONS AND TECHNICAL DATA

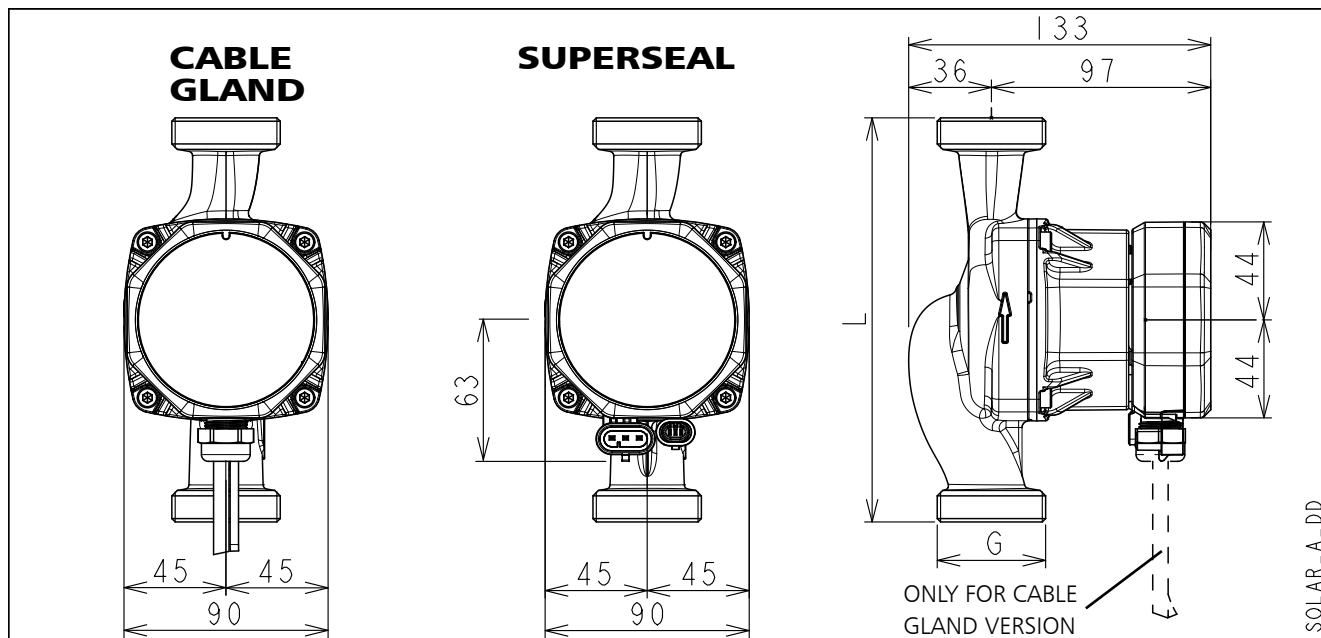

SOLAR\_A\_DD

Models	L [mm]	G
eco2S 15-15/130 CG	130	G 1 / R 1/2
eco2S 25-15/130 CG	130	G 1 1/2 / R 1
eco2S 25-15/180 CG	180	G 1 1/2 / R 1
eco2S 15-15/130 TS	130	G 1 / R 1/2
eco2S 25-15/130 TS	130	G 1 1/2 / R 1
eco2S 25-15/180 TS	180	G 1 1/2 / R 1
eco2S PWMS 15-15/130 CG	130	G 1 / R 1/2
eco2S PWMS 25-15/130 CG	130	G 1 1/2 / R 1
eco2S PWMS 25-15/180 CG	180	G 1 1/2 / R 1
eco2S PWMS 15-15/130 TS	130	G 1 / R 1/2
eco2S PWMS 25-15/130 TS	130	G 1 1/2 / R 1
eco2S PWMS 25-15/180 TS	180	G 1 1/2 / R 1

En-Rev\_A

Technical Data	
Rated voltage	1 x 230 V ±10%
Frequency	50/60 Hz
Power absorbed [W] (min/max)	4,7 / 52
	PWM: 1,8 / 52
Input current [A] (min/max)	0,05 / 0,45
	PWM: 0,02 / 0,45
Stand-by power [W]	< 1
Specific EEI ≤	0,17
IP protection	44
Insulation class	155 (F)
Max. working pressure	1,0 MPa (10 bar)
Liquid temperature	-10°C to +110 °C
Sound pressure level	≤ 43 dB(A)
Port nominal diameter	DN15, DN25
Port to port	130 mm, 180 mm
Pump body material	Cast Iron

En-Rev\_B

**eco2S ..-15/ SERIES  
PERFORMANCE CURVES**

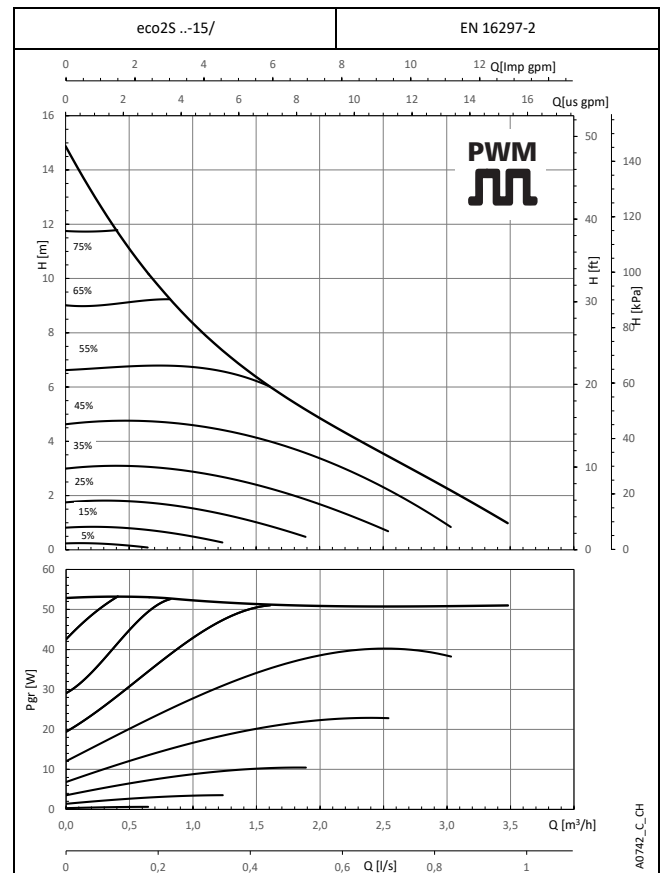
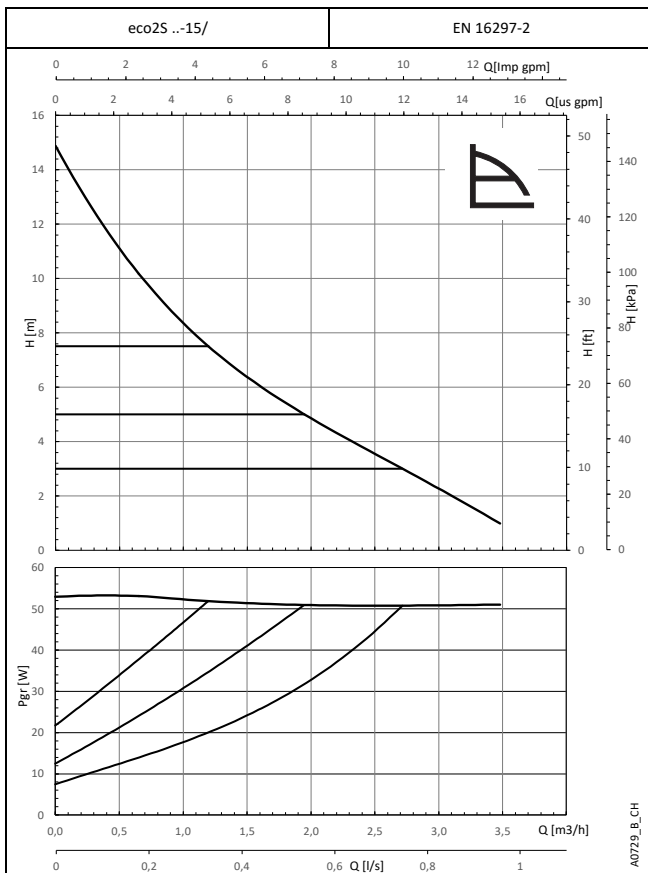
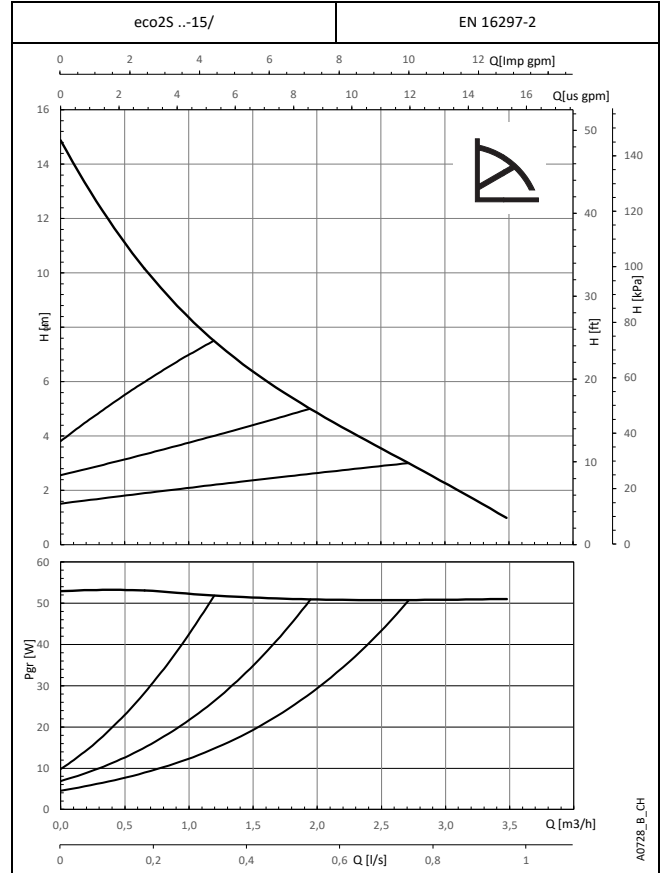
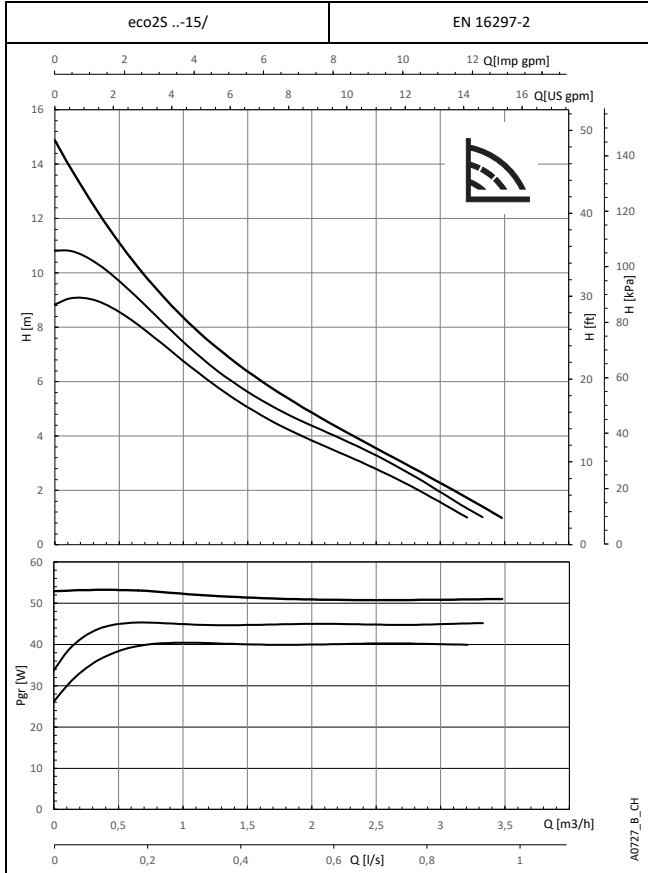

These performances are valid for liquids with density  $\rho = 1.0 \text{ Kg/dm}^3$  and kinematic viscosity  $\nu = 1 \text{ mm}^2/\text{sec}$ .  
Pump operates steplessly. Lines correspond to knob settings and are for reference only.

## eco2 SERIES IN BRIEF

Models	Part Number	EEL ≤	Limit Power [W]	Port nominal diameter	Connection type	Max Port to head [m]	port [mm]	Pump body material
eco2 15-4/130 CG	60B0L1100YYY000	0,16	24	DN15	Cable gland	4	130	Cast Iron
eco2 15-6/130 CG	60B0L1100YYY001	0,17	34	DN15	Cable gland	6	130	Cast Iron
eco2 15-8/130 CG	60B0L1100YYY002	0,18	55	DN15	Cable gland	8	130	Cast Iron
eco2 15-4/130N CG	60B0L1100YYY003	0,16	24	DN15	Cable gland	4	130	Stainless Steel
eco2 15-6/130N CG	60B0L1100YYY004	0,17	34	DN15	Cable gland	6	130	Stainless Steel
eco2 15-8/130N CG	60B0L1100YYY005	0,18	55	DN15	Cable gland	8	130	Stainless Steel
eco2 15-4/130C CG	60B0L1100YYY006	0,18	24	DN15	Cable gland	4	130	Composite
eco2 15-6/130C CG	60B0L1100YYY007	0,20	38	DN15	Cable gland	6	130	Composite
eco2 15-8/130C CG	60B0L1100YYY008	0,20	55	DN15	Cable gland	8	130	Composite
eco2 15-6/END CG	60B0L1100YYY009	0,17	34	DN15	Cable gland	6	End	Cast iron
eco2 15-8/END CG	60B0L1100YYY010	0,18	55	DN15	Cable gland	8	End	Cast iron
eco2 25-4/130 CG	60B0L1100YYY011	0,16	24	DN25	Cable gland	4	130	Cast Iron
eco2 25-6/130 CG	60B0L1100YYY012	0,17	34	DN25	Cable gland	6	130	Cast Iron
eco2 25-8/130 CG	60B0L1100YYY013	0,18	55	DN25	Cable gland	8	130	Cast Iron
eco2 25-4/130N CG	60B0L1100YYY020	0,16	24	DN25	Cable gland	4	130	Stainless Steel
eco2 25-6/130N CG	60B0L1100YYY021	0,17	34	DN25	Cable gland	6	130	Stainless Steel
eco2 25-8/130N CG	60B0L1100YYY022	0,18	55	DN25	Cable gland	8	130	Stainless Steel
eco2 25-4/180 CG	60B0L1100YYY014	0,16	24	DN25	Cable gland	4	180	Cast Iron
eco2 25-6/180 CG	60B0L1100YYY015	0,17	34	DN25	Cable gland	6	180	Cast Iron
eco2 25-8/180 CG	60B0L1100YYY016	0,18	55	DN25	Cable gland	8	180	Cast Iron
eco2 25-4/180N CG	60B0L1100YYY023	0,16	24	DN25	Cable gland	4	180	Stainless Steel
eco2 25-6/180N CG	60B0L1100YYY024	0,17	34	DN25	Cable gland	6	180	Stainless Steel
eco2 25-8/180N CG	60B0L1100YYY025	0,18	55	DN25	Cable gland	8	180	Stainless Steel
eco2 32-4/180 CG	60B0L1100YYY017	0,16	24	DN32	Cable gland	4	180	Cast Iron
eco2 32-6/180 CG	60B0L1100YYY018	0,17	34	DN32	Cable gland	6	180	Cast Iron
eco2 32-8/180 CG	60B0L1100YYY019	0,18	55	DN32	Cable gland	8	180	Cast Iron
eco2 32-4/180N CG	60B0L1100YYY026	0,16	24	DN32	Cable gland	4	180	Stainless Steel
eco2 32-6/180N CG	60B0L1100YYY027	0,17	34	DN32	Cable gland	6	180	Stainless Steel
eco2 32-8/180N CG	60B0L1100YYY028	0,18	55	DN32	Cable gland	8	180	Stainless Steel
eco2 15-4/130 TS	60B0L1100YYY029	0,16	24	DN15	Superseal plug	4	130	Cast Iron
eco2 15-6/130 TS	60B0L1100YYY030	0,17	34	DN15	Superseal plug	6	130	Cast Iron
eco2 15-8/130 TS	60B0L1100YYY031	0,18	55	DN15	Superseal plug	8	130	Cast Iron
eco2 15-4/130N TS	60B0L1100YYY032	0,16	24	DN15	Superseal plug	4	130	Stainless Steel
eco2 15-6/130N TS	60B0L1100YYY033	0,17	34	DN15	Superseal plug	6	130	Stainless Steel
eco2 15-8/130N TS	60B0L1100YYY034	0,18	55	DN15	Superseal plug	8	130	Stainless Steel
eco2 15-4/130C TS	60B0L1100YYY035	0,18	24	DN15	Superseal plug	4	130	Composite
eco2 15-6/130C TS	60B0L1100YYY036	0,20	38	DN15	Superseal plug	6	130	Composite
eco2 15-8/130C TS	60B0L1100YYY037	0,20	55	DN15	Superseal plug	8	130	Composite
eco2 15-6/END TS	60B0L1100YYY038	0,17	34	DN15	Superseal plug	6	End	Cast iron
eco2 15-8/END TS	60B0L1100YYY039	0,18	55	DN15	Superseal plug	8	End	Cast iron
eco2 25-4/130 TS	60B0L1100YYY040	0,16	24	DN25	Superseal plug	4	130	Cast Iron
eco2 25-6/130 TS	60B0L1100YYY041	0,17	34	DN25	Superseal plug	6	130	Cast Iron
eco2 25-8/130 TS	60B0L1100YYY042	0,18	55	DN25	Superseal plug	8	130	Cast Iron
eco2 25-4/130N TS	60B0L1100YYY049	0,16	24	DN25	Superseal plug	4	130	Stainless Steel
eco2 25-6/130N TS	60B0L1100YYY050	0,17	34	DN25	Superseal plug	6	130	Stainless Steel
eco2 25-8/130N TS	60B0L1100YYY051	0,18	55	DN25	Superseal plug	8	130	Stainless Steel
eco2 25-6/130C TS	60B0L1100YYY076	0,20	38	DN25	Superseal plug	6	130	Composite
eco2 25-8/130C TS	60B0L1100YYY077	0,20	55	DN25	Superseal plug	8	130	Composite
eco2 25-4/180 TS	60B0L1100YYY043	0,16	24	DN25	Superseal plug	4	180	Cast Iron
eco2 25-6/180 TS	60B0L1100YYY044	0,17	34	DN25	Superseal plug	6	180	Cast Iron
eco2 25-8/180 TS	60B0L1100YYY045	0,18	55	DN25	Superseal plug	8	180	Cast Iron
eco2 25-4/180N TS	60B0L1100YYY052	0,16	24	DN25	Superseal plug	4	180	Stainless Steel
eco2 25-6/180N TS	60B0L1100YYY053	0,17	34	DN25	Superseal plug	6	180	Stainless Steel
eco2 25-8/180N TS	60B0L1100YYY054	0,18	55	DN25	Superseal plug	8	180	Stainless Steel
eco2 32-4/180 TS	60B0L1100YYY046	0,16	24	DN32	Superseal plug	4	180	Cast Iron
eco2 32-6/180 TS	60B0L1100YYY047	0,17	34	DN32	Superseal plug	6	180	Cast Iron
eco2 32-8/180 TS	60B0L1100YYY048	0,18	55	DN32	Superseal plug	8	180	Cast Iron
eco2 32-4/180N TS	60B0L1100YYY055	0,16	24	DN32	Superseal plug	4	180	Stainless Steel
eco2 32-6/180N TS	60B0L1100YYY056	0,17	34	DN32	Superseal plug	6	180	Stainless Steel
eco2 32-8/180N TS	60B0L1100YYY057	0,18	55	DN32	Superseal plug	8	180	Stainless Steel

## eco2 SERIES IN BRIEF

Models	Part Number	EEL ≤	Limit Power [W]	Port nominal diameter	Connection type	Max Port to head [m]	Port [mm]	Pump body material
eco2 PWMH 15-4/130 CG	60B0L2100YYY000	0,16	24	DN15	Power + signal cable gland	4	130	Cast Iron
eco2 PWMH 15-6/130 CG	60B0L2100YYY001	0,17	34	DN15	Power + signal cable gland	6	130	Cast Iron
eco2 PWMH 15-8/130 CG	60B0L2100YYY002	0,18	55	DN15	Power + signal cable gland	8	130	Cast Iron
eco2 PWMH 15-4/130N CG	60B0L2100YYY003	0,16	24	DN15	Power + signal cable gland	4	130	Stainless Steel
eco2 PWMH 15-6/130N CG	60B0L2100YYY004	0,17	34	DN15	Power + signal cable gland	6	130	Stainless Steel
eco2 PWMH 15-8/130N CG	60B0L2100YYY005	0,18	55	DN15	Power + signal cable gland	8	130	Stainless Steel
eco2 PWMH 15-4/130C CG	60B0L2100YYY006	0,18	24	DN15	Power + signal cable gland	4	130	Composite
eco2 PWMH 15-6/130C CG	60B0L2100YYY007	0,20	38	DN15	Power + signal cable gland	6	130	Composite
eco2 PWMH 15-8/130C CG	60B0L2100YYY008	0,20	55	DN15	Power + signal cable gland	8	130	Composite
eco2 PWMH 25-4/130 CG	60B0L2100YYY009	0,16	24	DN25	Power + signal cable gland	4	130	Cast Iron
eco2 PWMH 25-6/130 CG	60B0L2100YYY010	0,17	34	DN25	Power + signal cable gland	6	130	Cast Iron
eco2 PWMH 25-8/130 CG	60B0L2100YYY011	0,18	55	DN25	Power + signal cable gland	8	130	Cast Iron
eco2 PWMH 25-4/130N CG	60B0L2100YYY018	0,16	24	DN25	Power + signal cable gland	4	130	Stainless Steel
eco2 PWMH 25-6/130N CG	60B0L2100YYY019	0,17	34	DN25	Power + signal cable gland	6	130	Stainless Steel
eco2 PWMH 25-8/130N CG	60B0L2100YYY020	0,18	55	DN25	Power + signal cable gland	8	130	Stainless Steel
eco2 PWMH 25-4/180 CG	60B0L2100YYY012	0,16	24	DN25	Power + signal cable gland	4	180	Cast Iron
eco2 PWMH 25-6/180 CG	60B0L2100YYY013	0,17	34	DN25	Power + signal cable gland	6	180	Cast Iron
eco2 PWMH 25-8/180 CG	60B0L2100YYY014	0,18	55	DN25	Power + signal cable gland	8	180	Cast Iron
eco2 PWMH 25-4/180N CG	60B0L2100YYY021	0,16	24	DN25	Power + signal cable gland	4	180	Stainless Steel
eco2 PWMH 25-6/180N CG	60B0L2100YYY022	0,17	34	DN25	Power + signal cable gland	6	180	Stainless Steel
eco2 PWMH 25-8/180N CG	60B0L2100YYY023	0,18	55	DN25	Power + signal cable gland	8	180	Stainless Steel
eco2 PWMH 32-4/180 CG	60B0L2100YYY015	0,16	24	DN32	Power + signal cable gland	4	180	Cast Iron
eco2 PWMH 32-6/180 CG	60B0L2100YYY016	0,17	34	DN32	Power + signal cable gland	6	180	Cast Iron
eco2 PWMH 32-8/180 CG	60B0L2100YYY017	0,18	55	DN32	Power + signal cable gland	8	180	Cast Iron
eco2 PWMH 32-4/180N CG	60B0L2100YYY024	0,16	24	DN32	Power + signal cable gland	4	180	Stainless Steel
eco2 PWMH 32-6/180N CG	60B0L2100YYY025	0,17	34	DN32	Power + signal cable gland	6	180	Stainless Steel
eco2 PWMH 32-8/180N CG	60B0L2100YYY026	0,18	55	DN32	Power + signal cable gland	8	180	Stainless Steel
eco2 PWMH 15-4/130 TS	60B0L2100YYY027	0,16	24	DN15	Superseal plug + mini-superseal	4	130	Cast Iron
eco2 PWMH 15-6/130 TS	60B0L2100YYY028	0,17	34	DN15	Superseal plug + mini-superseal	6	130	Cast Iron
eco2 PWMH 15-8/130 TS	60B0L2100YYY029	0,18	55	DN15	Superseal plug + mini-superseal	8	130	Cast Iron
eco2 PWMH 15-4/130N TS	60B0L2100YYY030	0,16	24	DN15	Superseal plug + mini-superseal	4	130	Stainless Steel
eco2 PWMH 15-6/130N TS	60B0L2100YYY031	0,17	34	DN15	Superseal plug + mini-superseal	6	130	Stainless Steel
eco2 PWMH 15-8/130N TS	60B0L2100YYY032	0,18	55	DN15	Superseal plug + mini-superseal	8	130	Stainless Steel
eco2 PWMH 15-4/130C TS	60B0L2100YYY033	0,18	24	DN15	Superseal plug + mini-superseal	4	130	Composite
eco2 PWMH 15-6/130C TS	60B0L2100YYY034	0,20	38	DN15	Superseal plug + mini-superseal	6	130	Composite
eco2 PWMH 15-8/130C TS	60B0L2100YYY035	0,20	55	DN15	Superseal plug + mini-superseal	8	130	Composite
eco2 PWMH 25-4/130 TS	60B0L2100YYY036	0,16	24	DN25	Superseal plug + mini-superseal	4	130	Cast Iron
eco2 PWMH 25-6/130 TS	60B0L2100YYY037	0,17	34	DN25	Superseal plug + mini-superseal	6	130	Cast Iron
eco2 PWMH 25-8/130 TS	60B0L2100YYY038	0,18	55	DN25	Superseal plug + mini-superseal	8	130	Cast Iron
eco2 PWMH 25-4/130N TS	60B0L2100YYY045	0,16	24	DN25	Superseal plug + mini-superseal	4	130	Stainless Steel
eco2 PWMH 25-6/130N TS	60B0L2100YYY046	0,17	34	DN25	Superseal plug + mini-superseal	6	130	Stainless Steel
eco2 PWMH 25-8/130N TS	60B0L2100YYY047	0,18	55	DN25	Superseal plug + mini-superseal	8	130	Stainless Steel
eco2 PWMH 25-6/130C TS	60B0L2100YYY078	0,20	38	DN25	Superseal plug + mini-superseal	6	130	Composite
eco2 PWMH 25-8/130C TS	60B0L2100YYY079	0,20	55	DN25	Superseal plug + mini-superseal	8	130	Composite
eco2 PWMH 25-4/180 TS	60B0L2100YYY039	0,16	24	DN25	Superseal plug + mini-superseal	4	180	Cast Iron
eco2 PWMH 25-6/180 TS	60B0L2100YYY040	0,17	34	DN25	Superseal plug + mini-superseal	6	180	Cast Iron
eco2 PWMH 25-8/180 TS	60B0L2100YYY041	0,18	55	DN25	Superseal plug + mini-superseal	8	180	Cast Iron
eco2 PWMH 25-4/180N TS	60B0L2100YYY048	0,16	24	DN25	Superseal plug + mini-superseal	4	180	Stainless Steel
eco2 PWMH 25-6/180N TS	60B0L2100YYY049	0,17	34	DN25	Superseal plug + mini-superseal	6	180	Stainless Steel
eco2 PWMH 25-8/180N TS	60B0L2100YYY050	0,18	55	DN25	Superseal plug + mini-superseal	8	180	Stainless Steel
eco2 PWMH 32-4/180 TS	60B0L2100YYY042	0,16	24	DN32	Superseal plug + mini-superseal	4	180	Cast Iron
eco2 PWMH 32-6/180 TS	60B0L2100YYY043	0,17	34	DN32	Superseal plug + mini-superseal	6	180	Cast Iron
eco2 PWMH 32-8/180 TS	60B0L2100YYY044	0,18	55	DN32	Superseal plug + mini-superseal	8	180	Cast Iron
eco2 PWMH 32-4/180N TS	60B0L2100YYY051	0,16	24	DN32	Superseal plug + mini-superseal	4	180	Stainless Steel
eco2 PWMH 32-6/180N TS	60B0L2100YYY052	0,17	34	DN32	Superseal plug + mini-superseal	6	180	Stainless Steel
eco2 PWMH 32-8/180N TS	60B0L2100YYY053	0,18	55	DN32	Superseal plug + mini-superseal	8	180	Stainless Steel

**eco2 SERIES IN BRIEF**

Models	Part Number	EEl ≤	Limit Power [W]	Port nominal diameter	Connection type	Max Port to head [m]	Port [mm]	Pump body material
eco2S 15-8/130 CG	60B0L1100YYY058	0,18	52	DN15	cable gland	8	130	Cast iron
eco2S 15-15/130 CG	60B0L1100YYY059	0,17	52	DN15	cable gland	15	130	Cast iron
eco2S 25-8/130 CG	60B0L1100YYY060	0,18	52	DN25	cable gland	8	130	Cast iron
eco2S 25-15/130 CG	60B0L1100YYY061	0,17	52	DN25	cable gland	15	130	Cast iron
eco2S 25-8/180 CG	60B0L1100YYY062	0,18	52	DN25	cable gland	8	180	Cast iron
eco2S 25-15/180 CG	60B0L1100YYY063	0,17	52	DN25	cable gland	15	180	Cast iron
eco2S 15-8/130 TS	60B0L1100YYY064	0,18	52	DN15	superseal plug	8	130	Cast iron
eco2S 15-15/130 TS	60B0L1100YYY065	0,17	52	DN15	superseal plug	15	130	Cast iron
eco2S 25-8/130 TS	60B0L1100YYY066	0,18	52	DN25	superseal plug	8	130	Cast iron
eco2S 25-15/130 TS	60B0L1100YYY067	0,17	52	DN25	superseal plug	15	130	Cast iron
eco2S 25-8/180 TS	60B0L1100YYY068	0,18	52	DN25	superseal plug	8	180	Cast iron
eco2S 25-15/180 TS	60B0L1100YYY069	0,17	52	DN25	superseal plug	15	180	Cast iron
eco2S PWMS 15-8/130 CG	60B0L2100YYY060	0,18	52	DN15	Power + signal cable gland	8	130	Cast iron
eco2S PWMS 15-15/130 CG	60B0L2100YYY061	0,17	52	DN15	Power + signal cable gland	15	130	Cast iron
eco2S PWMS 25-8/130 CG	60B0L2100YYY062	0,18	52	DN25	Power + signal cable gland	8	130	Cast iron
eco2S PWMS 25-15/130 CG	60B0L2100YYY063	0,17	52	DN25	Power + signal cable gland	15	130	Cast iron
eco2S PWMS 25-8/180 CG	60B0L2100YYY064	0,18	52	DN25	Power + signal cable gland	8	180	Cast iron
eco2S PWMS 25-15/180 CG	60B0L2100YYY065	0,17	52	DN25	Power + signal cable gland	15	180	Cast iron
eco2S PWMS 15-8/130 TS	60B0L2100YYY054	0,18	52	DN15	Superseal plug + mini-superseal	8	130	Cast iron
eco2S PWMS 15-15/130 TS	60B0L2100YYY055	0,17	52	DN15	Superseal plug + mini-superseal	15	130	Cast iron
eco2S PWMS 25-8/130 TS	60B0L2100YYY056	0,18	52	DN25	Superseal plug + mini-superseal	8	130	Cast iron
eco2S PWMS 25-15/130 TS	60B0L2100YYY057	0,17	52	DN25	Superseal plug + mini-superseal	15	130	Cast iron
eco2S PWMS 25-8/180 TS	60B0L2100YYY058	0,18	52	DN25	Superseal plug + mini-superseal	8	180	Cast iron
eco2S PWMS 25-15/180 TS	60B0L2100YYY059	0,17	52	DN25	Superseal plug + mini-superseal	15	180	Cast iron
eco2M PWMM 15-6/130 CG	60B0L2100YYY066	0,17	34	DN15	Power + signal cable gland	6	130	Cast iron
eco2M PWMM 15-8/130 CG	60B0L2100YYY067	0,18	55	DN15	Power + signal cable gland	8	130	Cast iron
eco2M PWMM 25-6/130 CG	60B0L2100YYY068	0,17	34	DN25	Power + signal cable gland	6	130	Cast iron
eco2M PWMM 25-8/130 CG	60B0L2100YYY069	0,18	55	DN25	Power + signal cable gland	8	130	Cast iron
eco2M PWMM 25-6/180 CG	60B0L2100YYY070	0,17	34	DN25	Power + signal cable gland	6	180	Cast iron
eco2M PWMM 25-8/180 CG	60B0L2100YYY071	0,18	55	DN25	Power + signal cable gland	8	180	Cast iron
eco2M PWMM 15-6/130 TS	60B0L2100YYY072	0,17	34	DN15	Superseal plug + mini-superseal	6	130	Cast iron
eco2M PWMM 15-8/130 TS	60B0L2100YYY073	0,18	55	DN15	Superseal plug + mini-superseal	8	130	Cast iron
eco2M PWMM 25-6/130 TS	60B0L2100YYY074	0,17	34	DN25	Superseal plug + mini-superseal	6	130	Cast iron
eco2M PWMM 25-8/130 TS	60B0L2100YYY075	0,18	55	DN25	Superseal plug + mini-superseal	8	130	Cast iron
eco2M PWMM 25-6/180 TS	60B0L2100YYY076	0,17	34	DN25	Superseal plug + mini-superseal	6	180	Cast iron
eco2M PWMM 25-8/180 TS	60B0L2100YYY077	0,18	55	DN25	Superseal plug + mini-superseal	8	180	Cast iron



# Xylem |'zīləm|

- 1) The tissue in plants that brings water upward from the roots;
- 2) a leading global water technology company.

We're a global team unified in a common purpose: creating advanced technology solutions to the world's water challenges. Developing new technologies that will improve the way water is used, conserved, and re-used in the future is central to our work. Our products and services move, treat, analyze, monitor and return water to the environment, in public utility, industrial, residential and commercial building services settings. Xylem also provides a leading portfolio of smart metering, network technologies and advanced analytics solutions for water, electric and gas utilities. In more than 150 countries, we have strong, long-standing relationships with customers who know us for our powerful combination of leading product brands and applications expertise with a strong focus on developing comprehensive, sustainable solutions.

**For more information on how Xylem can help you, go to [www.xylem.com](http://www.xylem.com).**



For information and technical support  
Xylem Service Italia Srl

Via Dottor Vittorio Lombardi 14  
36075 - Montecchio Maggiore (VI) - Italy  
Tel. (+39) 0444 707111  
Fax (+39) 0444 491043  
[www.xylem.com/lowara](http://www.xylem.com/lowara)

Xylem Service Italia Srl reserves the right to make modification without prior notice.  
Lowara, Xylem are trademarks of Xylem Inc. or one of its subsidiaries  
© 2025 Xylem, Inc.