

50 Hz



G4OS-G4C-G6C-G6W-G8W-G10W-G12W Series

4" - 6" - 8" - 10" - 12"

SUBMERSIBLE MOTORS

ErP 2009/125/EC

Cod. G91004851 Rev. D Ed.06/2017

 **GOULDS**
WATER TECHNOLOGY
a xylem brand

CONTENTS

4" serie G4OS

Specifications.....	5
Motor cross section and table of materials.....	6
Dimensions and weight.....	8
Operating characteristic.....	9

4" serie G4C

Specifications.....	11
Motor cross section and table of materials.....	12
Dimensions and weight.....	15
Operating characteristic.....	16

6" serie G6C

Specifications.....	17
Motor cross section and table of materials.....	18
Dimensions and weight.....	20
Operating characteristic.....	21

6" serie G6W

Specifications.....	23
Motor cross section and table of materials.....	24
Dimensions and weight.....	27
Operating characteristic.....	28

8" serie G8W

Specifications.....	31
Motor cross section and table of materials.....	32
Dimensions and weight.....	35
Operating characteristic.....	36

10" serie G10W

Specifications.....	39
Motor cross section and table of materials.....	40
Dimensions and weight.....	43
Operating characteristic.....	44

12" serie G12W

Specifications.....	45
Motor cross section and table of materials.....	46
Dimensions and weight.....	49
Operating characteristic.....	50

Motor (ErP 2009/125/EC)	51
--------------------------------------	----

Motor - Control Panel Combination Table.....	53
--	----

Technical appendix	57
---------------------------------	----

4" Submersible motors G4OS Series

Submersible oil filled rewindable motors.



- **High starting torque**
- **Rewindable stator**
- **Power supply cable with extractable connector**
- **Mechanical seal**
- **Screws to fix the pump are included**
- **Approvals:**
- D.M. 174/2004

SPECIFICATIONS

- Stainless steel outer sleeve.
- Shaft extension and coupling dimensions to **NEMA** standards.
- **Class insulation:**
155 (F).
- **Protection class:**
IP68.
- Internal fluid suitable for contact with foodstuffs.
- Strong and durable compensating bellows.
- Axial load supported by angular bearings.
- Mechanical seal protected by sand guard.
- **Maximum immersion depth:**
150 m.
- Suitable for both vertical / horizontal installations
- **Maximum number of starts for hour at regular intervals:**
30 for direct start;
20 for impedance start.
- **Maximum water temperature:**
35°C.
Max. temperature applies to motors working in a installation capable of delivering a flow of water around the motor jacket of at least 0,08 m/s.
- **Water pH:**
from 4 to 8.

- **Axial thrust:**
3000 N from 0,37 to 2,2 kW;
6500 N from 3 to 7,5 kW.
- **Versions:**
 - Single-phase:
from 0,37 to 4 kW
220-240 V ± 6% 50 Hz
 - Three-phase:
from 0,37 to 7,5 kW
220-240 V, ± 6% 50 Hz
from 0,37 to 7,5 kW
380-415 V ± 6% 50 Hz

OPTIONAL FEATURES

- Different voltages and frequencies.
- Single-phase version up to 1,1 kW with built-in capacitor and motor protection (2W = Two Wire).
- Upper support with customized material.

For application limits, refer to technical appendix chapter.

ACCESSORIES

- Control panels.
- Drop cables.
- Coupling flanges.
- Cooling sleeves.
- Capacitors.

**G4OS MOTOR SERIES
MOTOR CROSS SECTION AND TABLE OF MATERIALS**

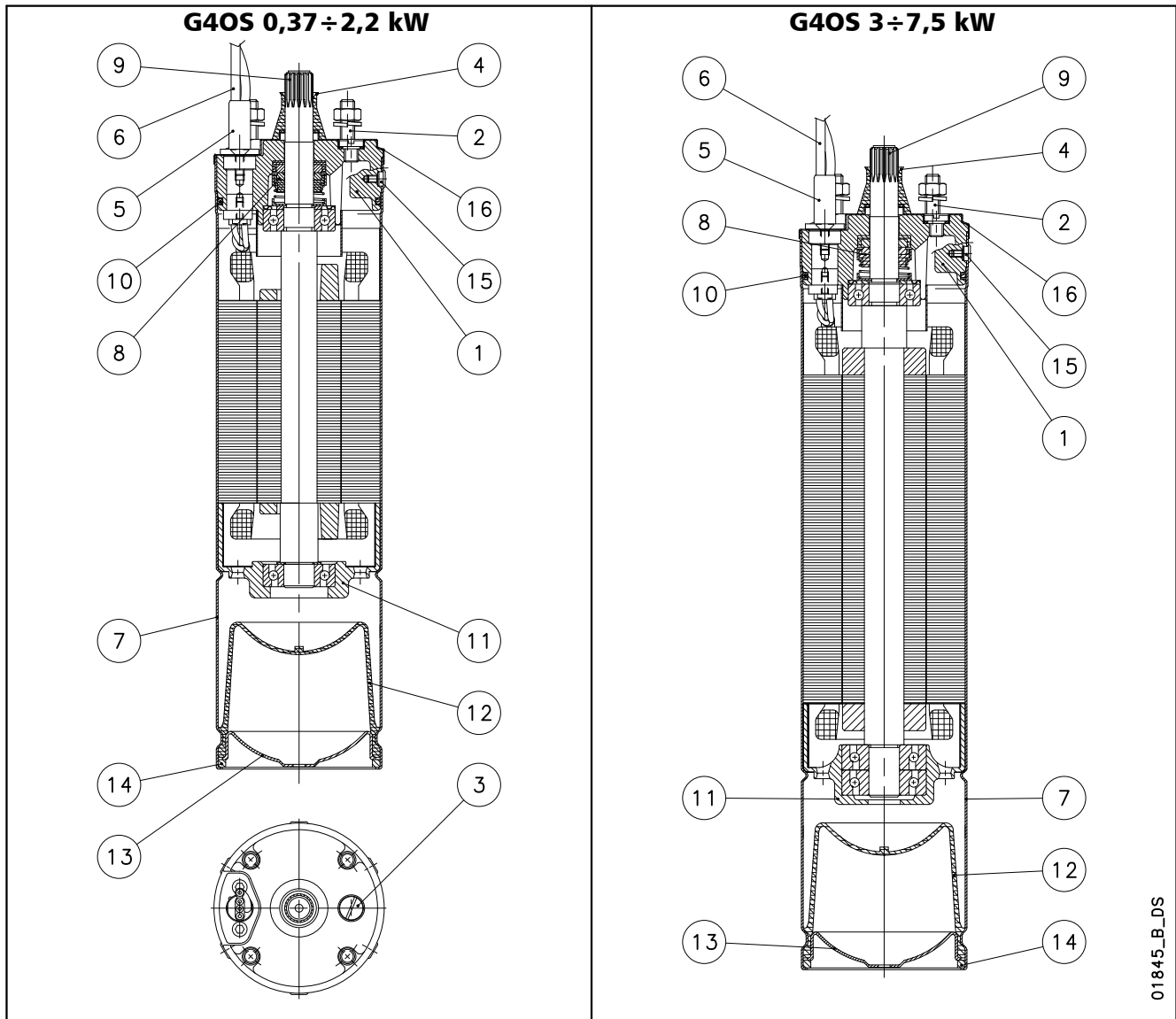

01845_B_DS

REF. N.	PART	MATERIAL	DESIGNATION	
			EUROPE	USA
1	Head	Cast iron	EN 1561-EN-GJL-200 (EN-JL1030)	ASTM A159-70-G3500
2	Studs	Stainless steel	EN 10088-3-X5CrNi18-10 (1.4301)	AISI 304
3	Filling screw	Brass	EN 12165-CuZn40Pb2 (CW617N)	
4	Sand guard	NBR		
5	Connector sleeve	Stainless steel	EN 10088-1-X5CrNi18-10 (1.4301)	AISI 304
6	Cable	EPDM		
7	Outer sleeve	Stainless steel	EN 10088-1-X5CrNi18-10 (1.4301)	AISI 304
8	Mechanical seal	Carbon / Ceramic		
9	Shaft end (up to 2.2 kW)	Stainless steel	EN 10088-3-X8CrNiS18-9 (1.4305)	AISI 303
	Shaft end (from 3 kW)	Stainless steel	EN 10088-1-X2CrNiMoN22-5-3 (1.4462)	ASTM A 182: F51
10	Elastomers	NBR		
11	Lower bracket	Cast iron	EN 1561-EN-GJL-200 (EN-JL1030)	ASTM A159-70-G3500
12	Compensating diaphragm	NBR		
13	Lower protection	Stainless steel	EN 10088-1-X5CrNi18-10 (1.4301)	AISI 304
14	Snap ring	Stainless steel	EN 10088-1-X5CrNi18-10 (1.4301)	AISI 304
15	Screws, nuts, washers	Stainless steel	EN 10088-3-X5CrNi18-10 (1.4301)	AISI 304
16	Upper cover	Stainless steel	EN 10088-1-X5CrNi18-10 (1.4301)	AISI 304
-	Cooling liquid	Non toxic oil		

G4OS SERIES IDENTIFICATION CODE

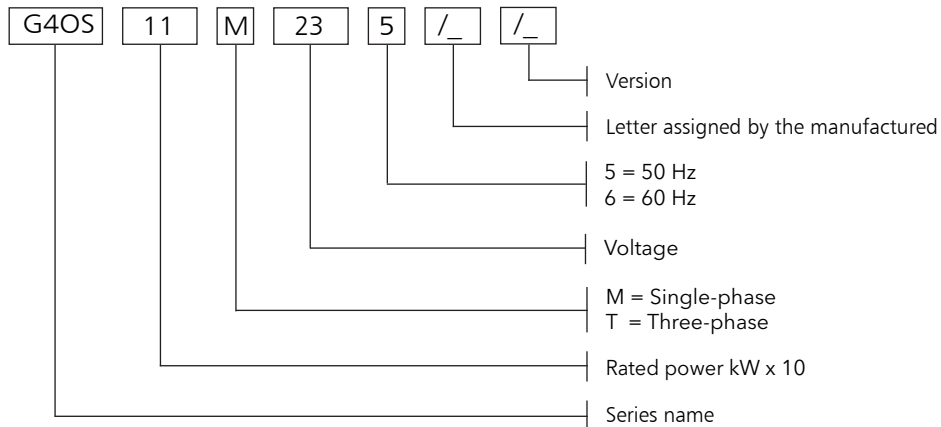

EXAMPLE: G4OS11M235

G4OS = Motor series G4OS
11 = Rated power 1,1 kW
M = Single-phase
23 = Voltage 220-240 V
5 = Frequency 50 Hz.

RATING PLATE

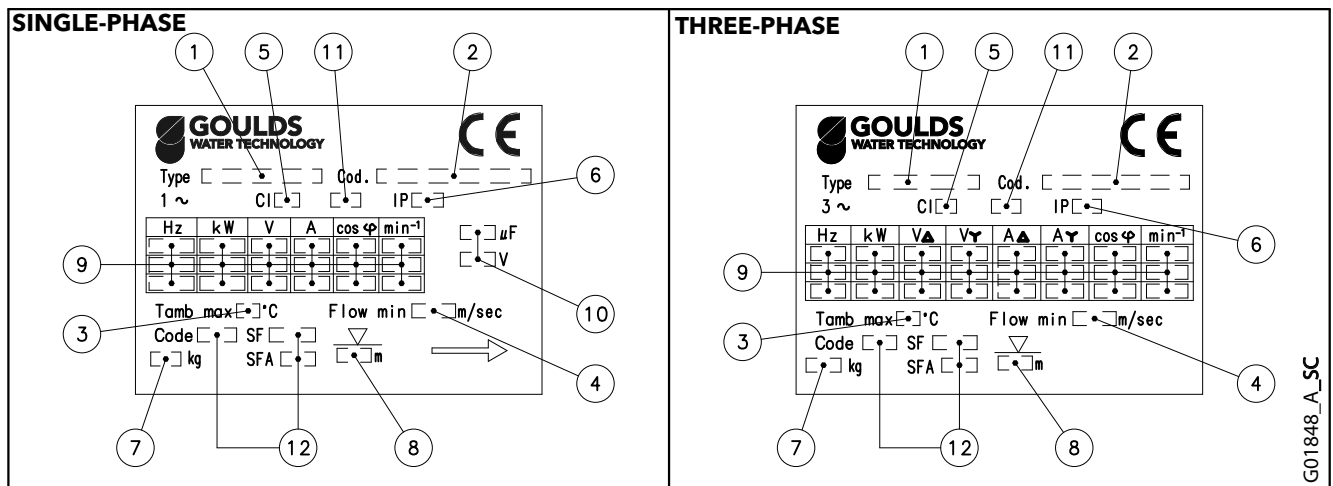

LEGEND

- 1 - Motor type
- 2 - Code
- 3 - Maximum water temperature
- 4 - Minimum water velocity
- 5 - Insulation class
- 6 - Protection class
- 7 - Weight
- 8 - Maximum immersion depth
- 9 - Operating characteristics
- 10 - Capacitor type
- 11 - Service type
- 12 - Characteristics NEMA MG1 (60Hz)

G4OS MOTOR SERIES DIMENSIONS AND WEIGHTS AT 50 Hz

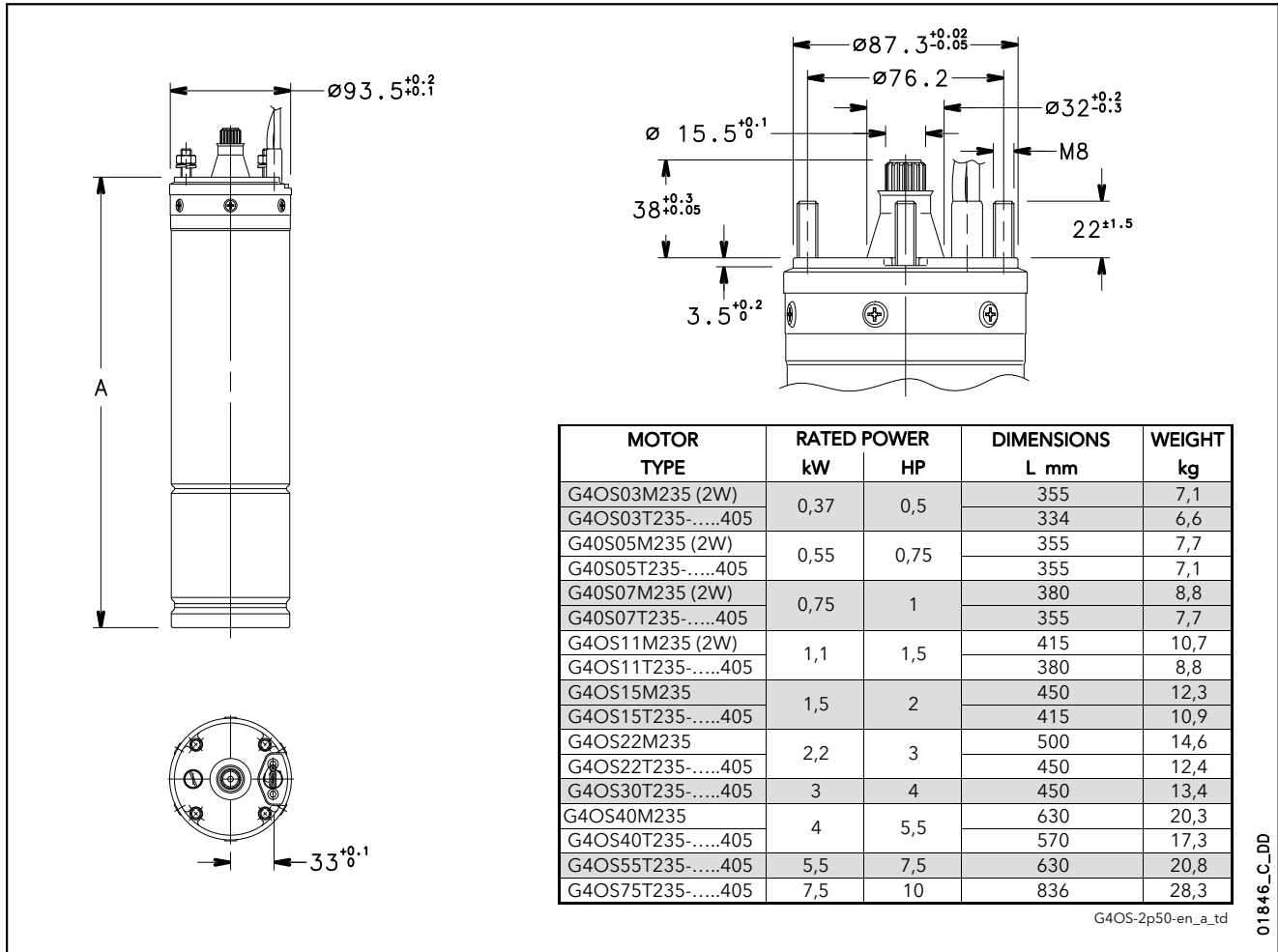

SINGLE-PHASE OPERATING CHARACTERISTICS AT 50 Hz

MOTOR TYPE	RATED POWER		RATED VOLTAGE	RATED CURRENT	CAPACITOR	OPERATING CHARACTERISTICS AT RATED POWER			DIRECT START		MAX WATER TEMPERATURE	CABLE TYPE (FLAT)	
	kW	HP				V	A	μF (450V)	rpm	η %		cosφ	Ts/Tn
G4OS03M235	0,37	0,5	220	3,0	16	2835	56,8	0,98	0,56	3,08	35	1,5	1,75
			230	3,1		2845	54,7	0,96	0,62	3,17			
			240	3,2		2860	52,5	0,93	0,68	3,2			
G4OS05M235	0,55	0,75	220	4,1	20	2815	62,4	0,98	0,60	2,93	35	1,5	1,75
			230	4,1		2830	60,4	0,96	0,66	3,02			
			240	4,3		2845	58,4	0,92	0,72	3,06			
G4OS07M235	0,75	1	220	5,4	30	2825	63,3	0,99	0,57	3,07	35	1,5	1,75
			230	5,5		2840	61,6	0,97	0,63	3,2			
			240	5,6		2855	59,9	0,94	0,69	3,27			
G4OS11M235	1,1	1,5	220	7,5	40	2820	67,6	0,99	0,62	2,97	35	1,5	1,75
			230	7,4		2840	66,3	0,98	0,68	3,14			
			240	7,6		2850	63,9	0,95	0,74	3,2			
G4OS15M235	1,5	2	220	10,0	50	2830	69,3	0,98	0,48	3,1	35	1,5	1,75
			230	10,1		2845	67,6	0,96	0,53	3,22			
			240	10,5		2855	64,9	0,92	0,58	3,22			
G4OS22M235	2,2	3	220	14,3	70	2805	71,1	0,99	0,46	2,71	35	1,5	2,5
			230	14,1		2820	69,6	0,97	0,50	2,86			
			240	14,4		2840	67,7	0,94	0,55	2,93			
G4OS40M235	4	5,5	220	25,7	90	2850	73,8	0,96	0,42	3,48	35	2	2,5
			230	24,9		2870	74,0	0,94	0,46	3,76			
			240	24,8		2880	73,4	0,92	0,50	3,94			

Ts/Tn = ratio between starting torque and nominal torque.

Is/In = ratio between starting current and nominal current

G4OS-M-2p50-en_a_te

G4OS MOTOR SERIES

THREE-PHASE OPERATING CHARACTERISTICS AT 50 Hz

MOTOR TYPE	RATED POWER		RATED CURRENT	RATED VOLTAGE	OPERATING CHARACTERISTICS AT RATED POWER			DIRECT START		MAX WATER TEMPERATURE	CABLE TYPE (FLAT)	
	THREE-PHASE	kW			HP	A	V	rpm	η %		$\cos\phi$	Ts/Tn
G4OS03T235	0,37	0,5	2,0	220	2835	62	0,78	3,4	5,1	35	1,5	1,75
			2,1	230	2855	62	0,72	3,8	5,3			
			2,2	240	2865	61	0,68	4,1	5,3			
G4OS05T235	0,55	0,75	2,8	220	2795	65	0,8	2,8	4,6	35	1,5	1,75
			2,9	230	2820	64	0,75	3,1	4,7			
			3,0	240	2835	63	0,71	3,4	4,7			
G4OS07T235	0,75	1	3,8	220	2790	68	0,78	3,3	4,6	35	1,5	1,75
			4,0	230	2815	67	0,71	3,6	4,7			
			4,2	240	2825	65	0,67	3,9	4,6			
G4OS11T235	1,1	1,5	5,1	220	2780	72	0,8	2,7	4,2	35	1,5	1,75
			5,2	230	2810	71	0,74	3,0	4,4			
			5,4	240	2820	70	0,7	3,2	4,3			
G4OS15T235	1,5	2	7,0	220	2790	73	0,78	3,0	4,7	35	1,5	1,75
			7,2	230	2815	72	0,72	3,4	4,8			
			7,6	240	2825	70	0,68	3,7	4,7			
G4OS22T235	2,2	3	9,7	220	2785	74	0,80	2,3	4,7	35	1,5	2,5
			10,0	230	2810	74	0,74	2,6	4,8			
			10,5	240	2825	73	0,69	2,7	4,7			
G4OS30T235	3	4	12,1	220	2810	77	0,85	1,8	4,2	35	1,5	2,5
			12,0	230	2830	77	0,81	2,0	4,5			
			12,3	240	2845	77	0,77	2,2	4,6			
G4OS40T235	4	5,5	16,4	220	2810	75	0,85	2,2	4,8	35	1,5	2,5
			16,5	230	2840	76	0,80	2,4	5,0			
			17,0	240	2850	75	0,76	2,6	5,0			
4OS55T235	5,5	7,5	22,9	220	2795	76	0,83	1,8	4,6	35	1,5	2,5
			23,0	230	2820	77	0,78	2,0	4,8			
			23,7	240	2840	77	0,73	2,2	4,9			
G4OS75T235	7,5	10	31,0	220	2820	78	0,82	1,9	4,9	35	1,5	4
			31,4	230	2850	79	0,76	2,1	5,1			
			32,4	240	2860	78	0,71	2,3	5,1			
G4OS03T405	0,37	0,5	1,2	380	2835	62	0,78	3,4	5,1	35	1,5	1,75
			1,2	400	2855	62	0,72	3,8	5,3			
			1,2	415	2865	61	0,68	4,1	5,3			
G4OS05T405	0,55	0,75	1,6	380	2795	65	0,8	2,8	4,6	35	1,5	1,75
			1,7	400	2820	64	0,75	3,1	4,7			
			1,7	415	2835	63	0,71	3,4	4,7			
G4OS07T405	0,75	1	2,2	380	2790	68	0,78	3,3	4,6	35	1,5	1,75
			2,3	400	2815	67	0,71	3,6	4,7			
			2,4	415	2825	65	0,67	3,9	4,6			
G4OS11T405	1,1	1,5	2,9	380	2780	72	0,8	2,7	4,2	35	1,5	1,75
			3,0	400	2810	71	0,74	3,0	4,4			
			3,1	415	2820	70	0,7	3,2	4,3			
G4OS15T405	1,5	2	4,0	380	2790	73	0,78	3,0	4,7	35	1,5	1,75
			4,2	400	2815	72	0,72	3,4	4,8			
			4,4	415	2825	70	0,68	3,7	4,7			
G4OS22T405	2,2	3	5,6	380	2785	74	0,80	2,3	4,7	35	1,5	2,5
			5,8	400	2810	74	0,74	2,6	4,8			
			6,1	415	2825	73	0,69	2,7	4,7			
G4OS30T405	3	4	7,0	380	2810	77	0,85	1,8	4,2	35	1,5	2,5
			7,0	400	2830	77	0,81	2,0	4,5			
			7,1	415	2845	77	0,77	2,2	4,6			
G4OS40T405	4	5,5	9,5	380	2810	75	0,85	2,2	4,8	35	1,5	2,5
			9,5	400	2840	76	0,80	2,4	5,0			
			9,8	415	2850	75	0,76	2,6	5,0			
G4OS55T405	5,5	7,5	13,2	380	2795	76	0,83	1,8	4,6	35	1,5	2,5
			13,3	400	2820	77	0,78	2,0	4,8			
			13,7	415	2840	77	0,73	2,2	4,9			
G4OS75T405	7,5	10	17,9	380	2820	78	0,82	1,9	4,9	35	1,5	4
			18,1	400	2850	79	0,76	2,1	5,1			
			18,7	415	2860	78	0,71	2,3	5,1			

Ts/Tn = ratio between starting torque and nominal torque.

Is/In = ratio between starting current and nominal current

G4OS-T-2p50-en_a_te

4" Submersible motors G4C Series

Submersible water filled encapsulated motors.



SPECIFICATIONS

- Stainless steel outer sleeve.
- Shaft extension and coupling dimensions to **NEMA** standards.
- **Class insulation:** 155 (F).
- **Protection class:** IP68.
- Internal fluid suitable for contact with foodstuffs.
- Strong and durable compensating bellows.
- Axial load supported by angular bearings.
- Mechanical seal protected by sand guard.
- **Maximum immersion depth:** 300 m.
- Suitable for both vertical / horizontal installations
- **Maximum number of starts per hour at regular intervals:** 40 for direct start; 20 for impedance start.
- **Maximum water temperature:** 35°C.
Max. temperature applies to motors working in a installation capable of delivering a flow of water around the motor jacket of at least 0,3 m/s.
- **Axial thrust:** 2000 N from 0,37 to 1,1 kW; 3000 N from 1,5 to 2,2 kW; 6000 N from 3 to 7,5 kW.

- **High starting torque**
- **Power supply cable with extractable connector**
- **Mechanical seal**
- **Kingsbury type thrust bearing**
- **Screws to fix the pump are included**

• Versions:

- Single-phase: from 0,37 to 4 kW (until 1,1 kW with built in automatic reset overload protection).
220-240 V ± 6% 50 Hz
- Three-phase: from 0,37 to 5,5 kW
220-240 V ± 6% 50 Hz
from 0,37 to 7,5 kW
380-415 V ± 6% 50 Hz

OPTIONAL FEATURES

- Different voltages and frequencies
- Single-phase version up to 1,1 kW with built-in capacitor and motor protection (2W = Two Wire).
- Upper support with customized material.

For application limits, refer to technical appendix chapter.

ACCESSORIES

- Control panels.
- Drop cables.
- Coupling flanges.
- Cooling sleeves.
- Capacitors.

**G4C MOTOR SERIES
MOTOR CROSS SECTION AND TABLE OF MATERIALS**

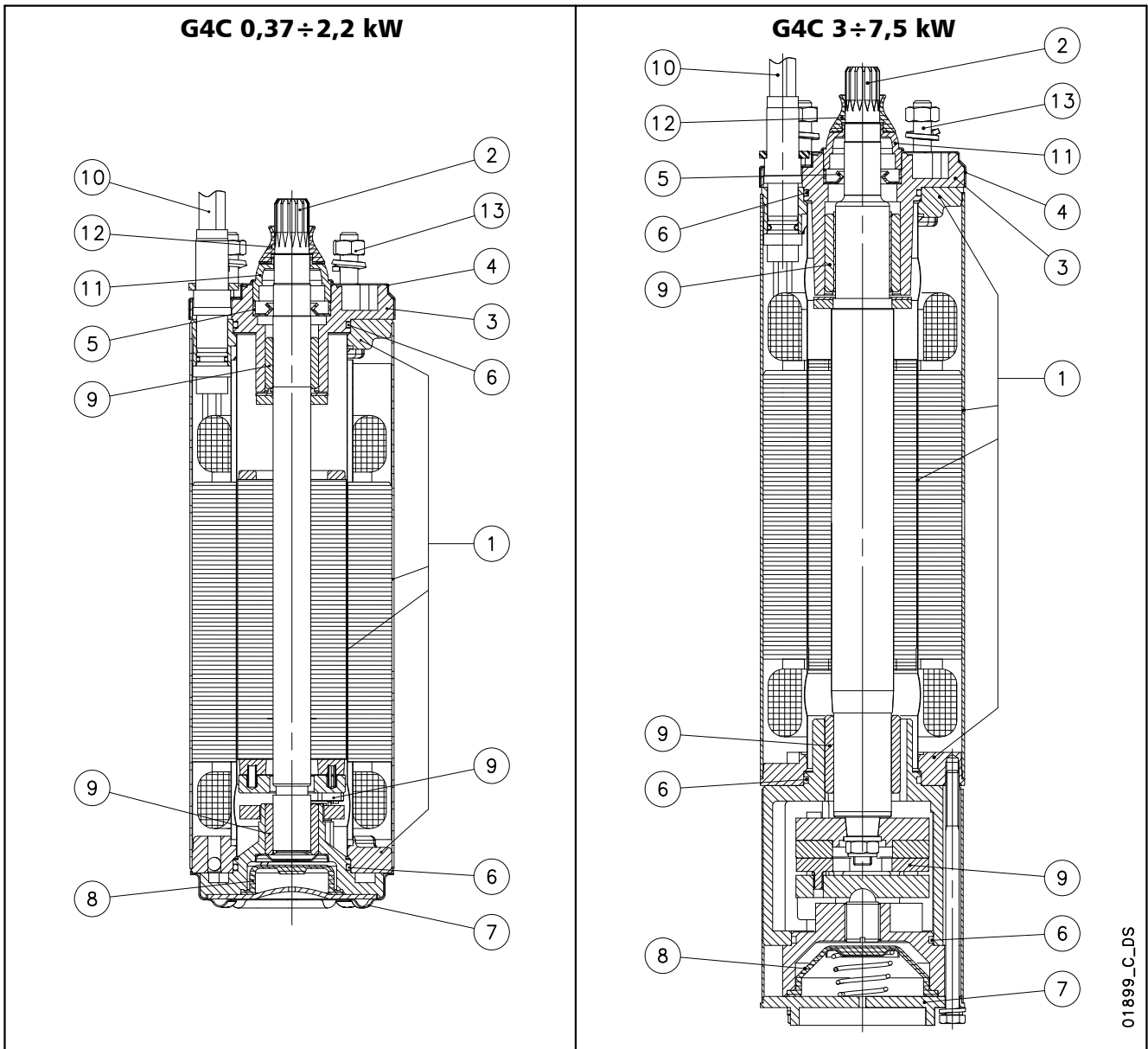

01899_C_DS

REF N°	PART	MATERIAL	DESIGNATION	
			EUROPE	USA
1	Inner, outer sleeves and flanges	Stainless steel	EN 10088-1-X2CrNi18-9 (1.4307)	AISI 304L
2	Shaft extension (up to 2.2 kW)	Stainless steel	EN 10088-1-X5CrNi18-10 (1.4301)	AISI 304
	Shaft extension (from 3 kW)	Stainless steel	EN 10088-3-X3CrNiMoN27 (1.4460)	AISI 329
3	Upper bracket	Cast iron	EN 1561-EN-GJL-200 (EN-JL1030)	Class 25 B
4	Upper cover	Stainless steel	EN 10088-1-X5CrNi18-10 (1.4301)	AISI 304
5	Lip seal	NBR		
6	Elastomers	NBR		
7	Lower cover (up to 2.2 kW)	Stainless steel	EN 10088-1-X5CrNi18-10 (1.4301)	AISI 304
	Lower cover (from 3 kW)	Cast iron	EN 1561-EN-GJL-200 (EN-JL1030)	Class 25 B
8	Compensating bellows	EPDM		
9	Bearings	Carbon-graphite		
10	Cable	EPDM		
11	Fixed sand guard	PA6		
12	Removable sand guard	NBR		
13	Bolts and screws	Stainless steel	EN ISO 3506-1 Grade A2	
-	Cooling liquid	Demineralized water + antifreeze		

**G4C (TWO WIRE) MOTOR SERIES
MOTOR CROSS SECTION AND TABLE OF MATERIALS**

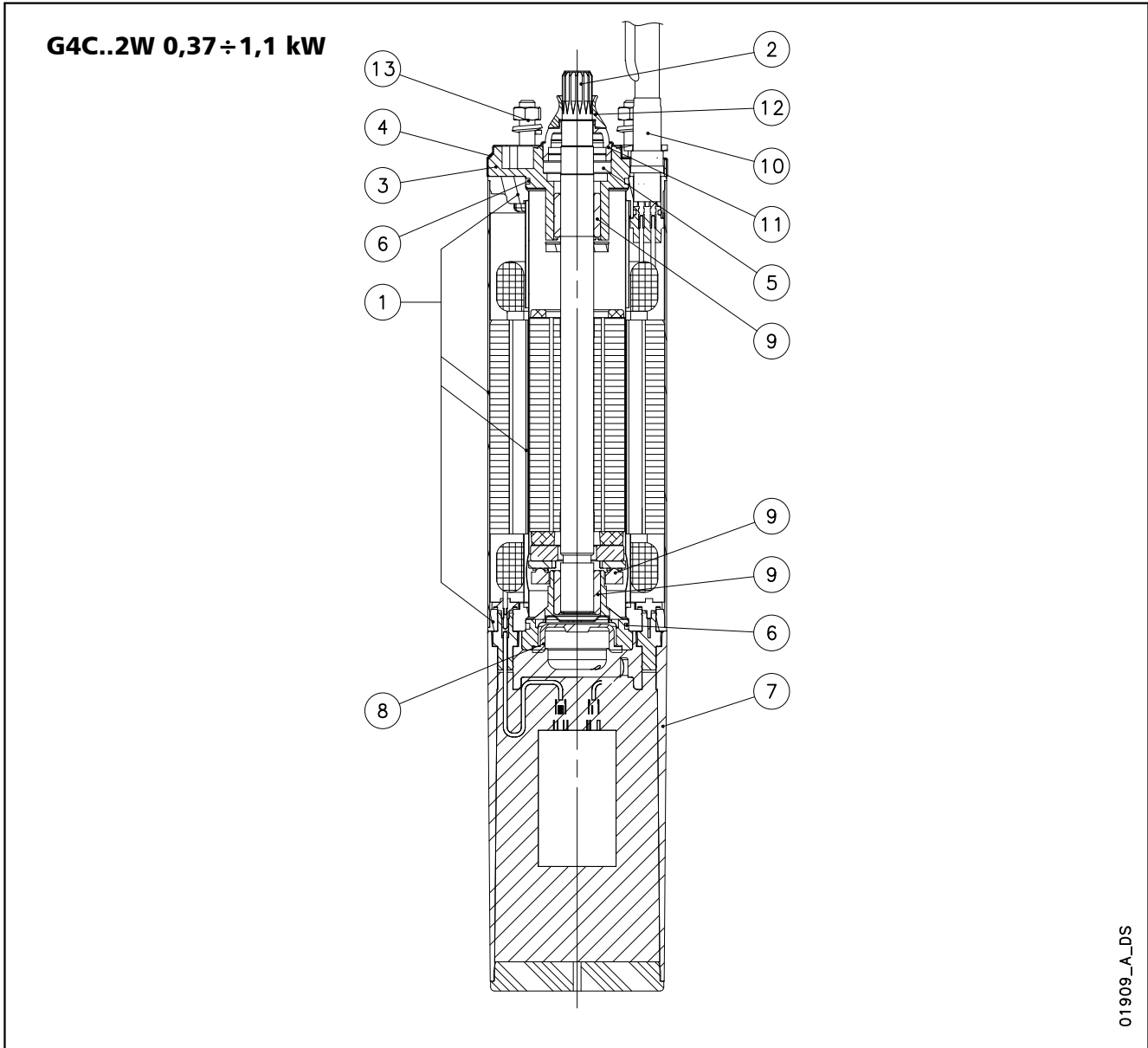

REF N°	PART	MATERIAL	DESIGNATION	
			EUROPE	USA
1	Inner, outer sleeves and flanges	Stainless steel	EN 10088-1-X2CrNi18-9 (1.4307)	AISI304L
2	Shaft extension	Stainless steel	EN 10088-1-X5CrNi18-10 (1.4301)	AISI304
3	Upper bracket	Cast iron	EN 1561-EN-GJL-200 (EN-JL1030)	Class 25 B
4	Upper cover	Stainless steel	EN 10088-1-X5CrNi18-10 (1.4301)	AISI304
5	Lip seal	NBR		
6	Elastomers	NBR		
7	Capacitor box	PPE		
8	Compensating bellows	EPDM		
9	Bearings	Carbon-graphite		
10	Cable	EPDM		
11	Fixed sand guard	PA6		
12	Removable sand guard	NBR		
13	Bolts and screws	Stainless steel	EN ISO 3506-1 Grade A2	
	Cooling liquid	Demineralized water + antifreeze		

G4C MOTOR SERIES IDENTIFICATION CODE

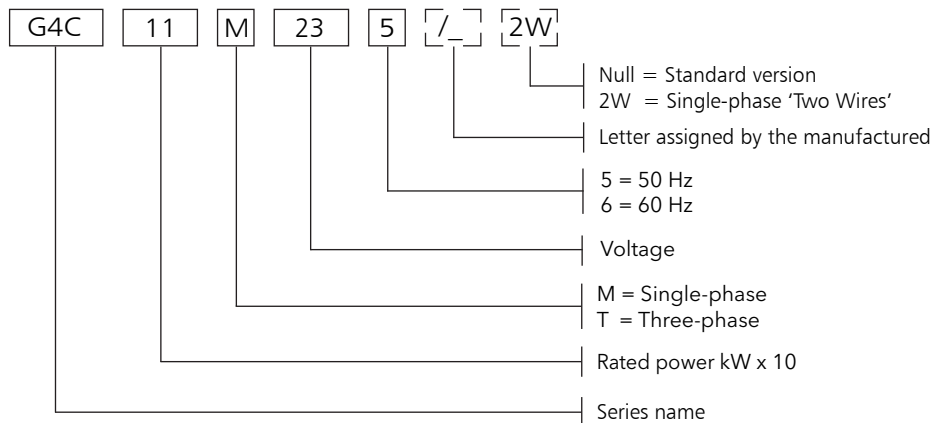

EXAMPLE: G4C11M235

G4C = Motor series G4C
11 = Rated power 1,1 kW
M = Single-phase
23 = Voltage 220-240 V
5 = Frequency 50 Hz.

RATING PLATE

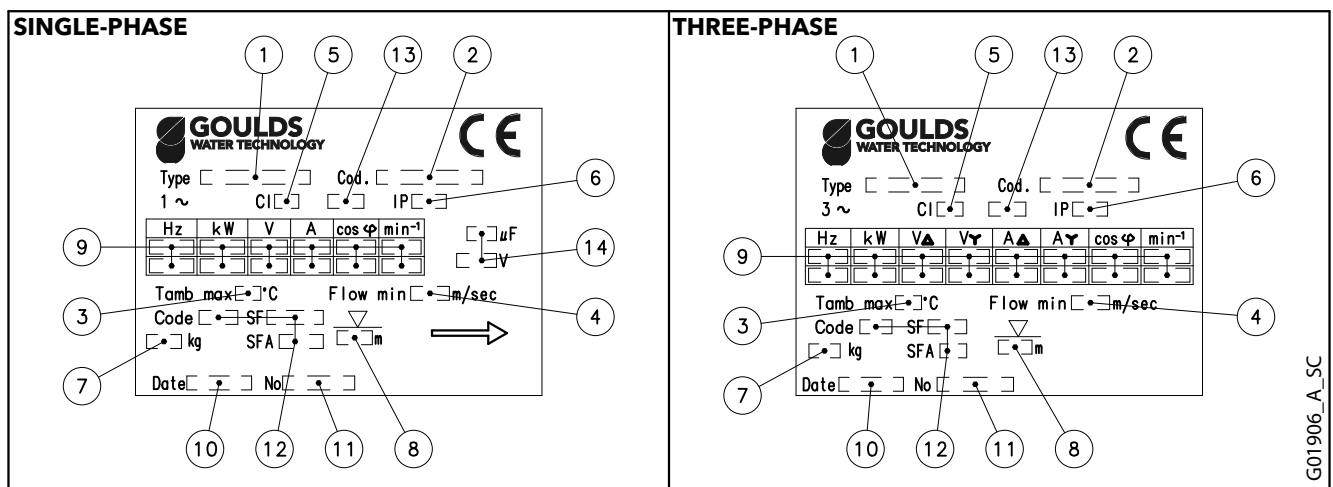

LEGEND

- 1 - Motor type
- 2 - Code
- 3 - Maximum water temperature
- 4 - Minimum water velocity
- 5 - Insulation class
- 6 - Protection class
- 7 - Weight
- 8 - Maximum immersion depth
- 9 - Operating characteristics
- 10 - Production date
- 11 - Serial number
- 12 - Characteristics NEMA MG1 (60Hz)
- 13 - Service type
- 14 - Capacitor type

G4C MOTOR SERIES DIMENSIONS AND WEIGHTS AT 50 Hz

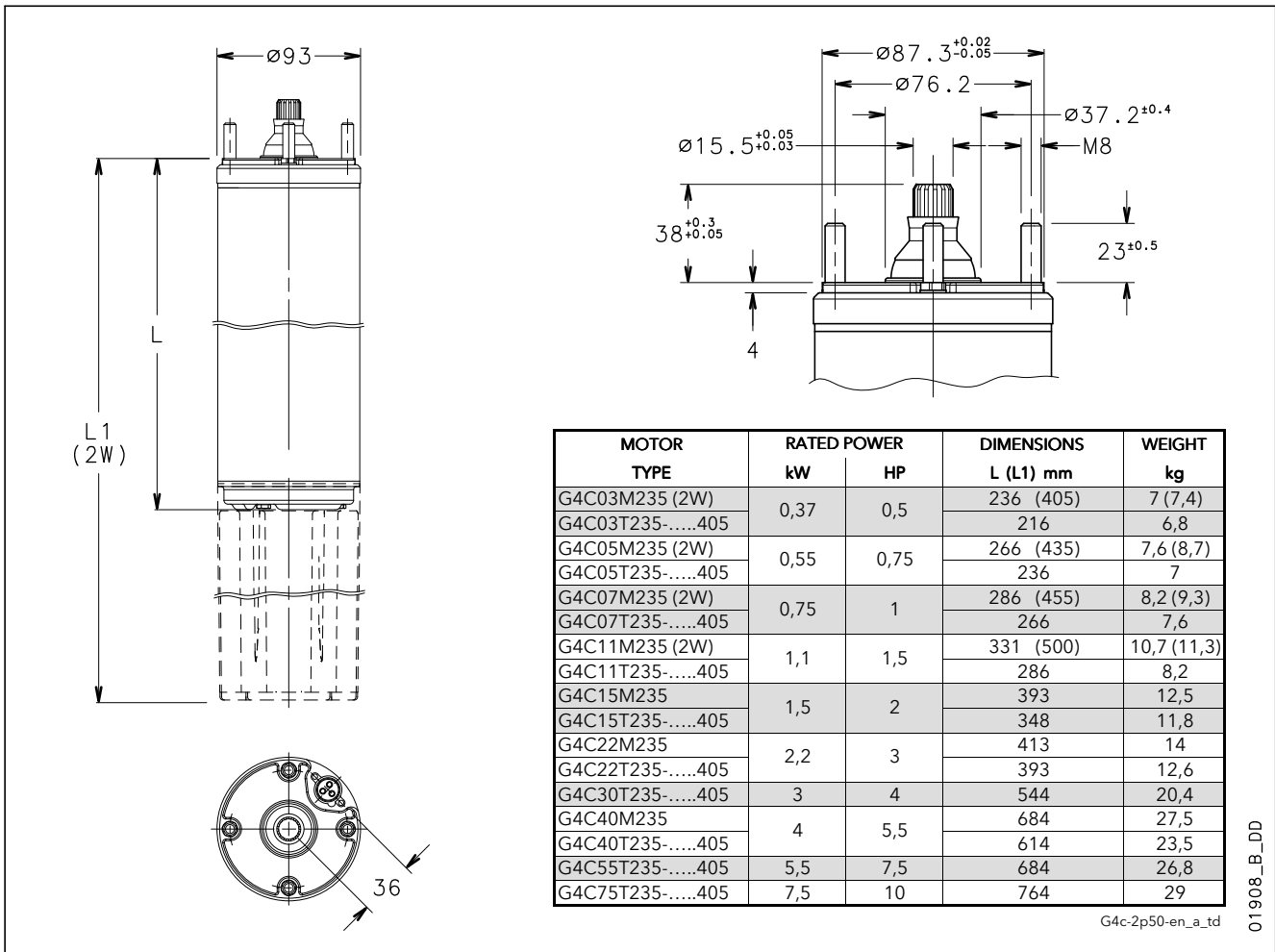

SINGLE-PHASE OPERATING CHARACTERISTICS AT 50 Hz

MOTOR TYPE	RATED POWER		RATED VOLTAGE	RATED CURRENT	CAPACITOR μF (450V)	OPERATING CHARACTERISTICS AT RATED POWER			DIRECT START		MAX WATER TEMPERATURE °C	CABLE TYPE (FLAT)	
	kW	HP	V	A		rpm	η %	cosφ	Ts/Tn	Is/In		4G ... * mm ²	L m
G4C03M235*	0,37	0,5	220	3,2	16	2810	53	0,96	0,63	2,68	35	1,5	1,7
			230	3,3		2820	54	0,97	0,69	2,72			
			240	3,4		2830	50	0,91	0,75	2,76			
G4C05M235*	0,55	0,75	220	4,3	20	2810	61	0,95	0,62	3,3	35	1,5	1,7
			230	4,6		2820	56	0,94	0,68	3,2			
			240	4,8		2830	54	0,90	0,74	3,26			
G4C07M235*	0,75	1	220	6	30	2810	60	0,93	0,63	3,18	35	1,5	1,7
			230	6,2		2820	58	0,92	0,66	3,2			
			240	6,5		2830	56	0,85	0,75	3,2			
G4C11M235*	1,1	1,5	220	8	40	2820	67	0,94	0,60	3,48	35	1,5	1,7
			230	8,1		2835	65	0,92	0,60	3,54			
			240	8,3		2850	63	0,87	0,62	3,62			
G4C15M235	1,5	2	220	10,4	50	2800	67	0,96	0,74	3,3	35	1,5	1,7
			230	10,4		2820	66	0,93	0,74	3,38			
			240	10,7		2835	64	0,90	0,76	3,46			
G4C22M235	2,2	3	220	15,4	70	2740	68	0,96	0,54	3,1	35	1,5	1,7
			230	15		2770	68	0,94	0,54	3,2			
			240	15,3		2790	66	0,91	0,54	3,3			
G4C40M235	4	5,5	220	29,9	90	2820	70	0,93	0,46	3,5	35	2	2,7
			230	29,8		2830	68	0,90	0,51	3,6			
			240	29,7		2840	65	0,87	0,60	3,4			

Ts/Tn = ratio between starting torque and nominal torque.

Is/In = ratio between starting current and nominal current

G4cm-2p50-en_a_te

* Cable 3G for models G4C03M235/2W, G4C05M235/2W, G4C07M235/2W, G4C11M235/2W

G4C MOTOR SERIES

THREE-PHASE OPERATING CHARACTERISTICS AT 50 Hz

MOTOR TYPE	RATED POWER		RATED VOLTAGE	RATED CURRENT	OPERATING CHARACTERISTICS AT RATED POWER			DIRECT STARTING		MAX WATER TEMPERATURE	CABLE TYPE (FLAT)	
	kw	HP			V	A	rpm	η %	$\cos\phi$		Ts/Tn	Is/In
G4C03T235	0,37	0,5	220	2,6	2810	51	0,69	2,7	3,7	35	1,5	1,7
			230	2,7	2820	53	0,7	3	3,7			
			240	3,1	2830	48	0,67	3,2	3,4			
G4C05T235	0,55	0,75	220	3,1	2820	61	0,77	2,8	4,3	35	1,5	1,7
			230	3,3	2830	60	0,71	3,1	4,2			
			240	3,5	2840	60	0,66	3,3	4,2			
G4C07T235	0,75	1	220	4	2820	65	0,77	2,9	5	35	1,5	1,7
			230	4,1	2830	63	0,73	3,2	5,1			
			240	4,5	2840	63	0,66	3,5	4,8			
G4C11T235	1,1	1,5	220	5,6	2820	62	0,8	3	4	35	1,5	1,7
			230	5,7	2830	64	0,76	3,3	4,2			
			240	6,2	2840	63	0,73	3,6	4			
G4C15T235	1,5	2	220	7,4	2820	68	0,77	3,1	4,2	35	1,5	1,7
			230	7,6	2830	68	0,72	3,4	4,3			
			240	8	2840	67	0,68	3,7	4,3			
G4C22T235	2,2	3	220	10	2810	72	0,8	3	4,3	35	1,5	1,7
			230	10,2	2820	71	0,78	3,2	4,4			
			240	10,7	2830	70	0,7	3,5	4,4			
G4C30T235	3	4	220	13,7	2830	75	0,77	3	4,6	35	1,5	2,7
			230	14,3	2840	74	0,71	3,3	4,6			
			240	15,2	2850	70	0,68	3,5	4,5			
G4C40T235	4	5,5	220	16,4	2840	76	0,81	3,10	5,6	35	2	2,7
			230	17,3	2850	75	0,79	3,40	5,6			
			240	18,2	2860	72	0,74	3,70	5,5			
G4C55T235	5,5	7,5	220	23,4	2840	78	0,79	3	5,4	35	2	2,7
			230	24,2	2850	77	0,74	3,4	5,5			
			240	25	2860	76	0,7	3,6	5,5			
G4C03T405	0,37	0,5	380	1,5	2810	51	0,69	2,7	3,8	35	1,5	1,7
			400	1,6	2820	53	0,7	3	3,8			
			415	1,8	2830	48	0,67	3,2	3,4			
G4C05T405	0,55	0,75	380	1,8	2820	61	0,77	2,8	4,2	35	1,5	1,7
			400	1,9	2830	60	0,71	3,1	4,2			
			415	2	2840	60	0,66	3,3	4,1			
G4C07T405	0,75	1	380	2,3	2820	65	0,77	2,9	5	35	1,5	1,7
			400	2,4	2830	63	0,73	3,2	5			
			415	2,6	2840	63	0,66	3,5	4,8			
G4C11T405	1,1	1,5	380	3,3	2820	62	0,8	3	4	35	1,5	1,7
			400	3,4	2830	64	0,76	3,3	4,1			
			415	3,6	2840	63	0,73	3,6	4			
G4C15T405	1,5	2	380	4,3	2820	68	0,77	3,1	4,2	35	1,5	1,7
			400	4,4	2830	68	0,72	3,4	4,3			
			415	4,6	2840	67	0,68	3,7	4,3			
G4C22T405	2,2	3	380	5,8	2810	72	0,8	3	4,1	35	1,5	1,7
			400	5,9	2820	71	0,78	3,2	4,4			
			415	6,2	2830	70	0,7	3,5	4,3			
G4C30T405	3	4	380	7,9	2830	75	0,77	3	4,5	35	1,5	2,7
			400	8,3	2840	74	0,71	3,3	4,6			
			415	8,8	2850	70	0,68	3,5	4,5			
G4C40T405	4	5,5	380	9,5	2840	76	0,81	3,1	5,6	35	1,5	2,7
			400	10	2850	75	0,79	3,4	5,6			
			415	10,5	2860	72	0,74	3,7	5,5			
G4C55T405	5,5	7,5	380	13,5	2840	78	0,79	3	5,4	35	1,5	2,7
			400	14	2850	77	0,74	3,4	5,5			
			415	14,5	2860	76	0,7	3,6	5,5			
G4C75T405	7,5	10	380	17	2840	80	0,84	2,6	4,7	35	2	3,5
			400	17,4	2850	79	0,79	2,9	4,8			
			415	18,1	2860	76	0,75	3,1	4,8			

Ts/Tn = ratio between starting torque and nominal torque.

Is/In = ratio between starting current and nominal current

G4ct-2p50-en_a-1e

6" Submersible motors G6C Series

Submersible water filled encapsulated motors.



- **High starting torque**
- **Power supply cable with extractable connector**
- **Mechanical seal**
- **Kingsbury type thrust bearing**
- **Screws to fix the pump are included**

SPECIFICATIONS

- Stainless steel outer sleeve.
- Shaft extension and coupling dimensions to **NEMA** standards.
- **Class insulation:** 155 (F).
- **Protection class:** IP68.
- Internal fluid suitable for contact with foodstuffs.
- Strong and durable compensating bellows.
- Axial load supported by angular bearings.
- Mechanical seal protected by sand guard.
- **Maximum immersion depth:** 250 m.
- Suitable for both vertical / horizontal installations
- **Maximum number of starts per hour at regular intervals:** 25 for direct start.
- **Maximum water temperature:** 35°C.
Max. temperature applies to motors working in an installation capable of delivering a flow of water around the motor jacket of at least 0,2 m/s.
- **Axial thrust:** 16000 N from 4 to 22 kW; 27000 N from 30 to 37 kW.

• Version:

- Three-phase:
from 4 to 22 kW
220-240 V ± 6% 50 Hz
from 4 to 37 kW
380-415 V ± 6% 50 Hz

OPTIONAL FEATURES

- Silicon Carbide mechanical seal.
- Different voltages and frequencies.
- Motors with double cable outlet for star/delta start can be supplied upon request.
- Temperature sensor **PT 100 / PTC.**

For application limits, refer to technical appendix chapter.

ACCESSORIES

- Control panels.
- Drop cables.
- Coupling flanges.
- Cooling sleeves.

**G6C MOTOR SERIES
MOTOR CROSS SECTION AND TABLE OF MATERIALS**

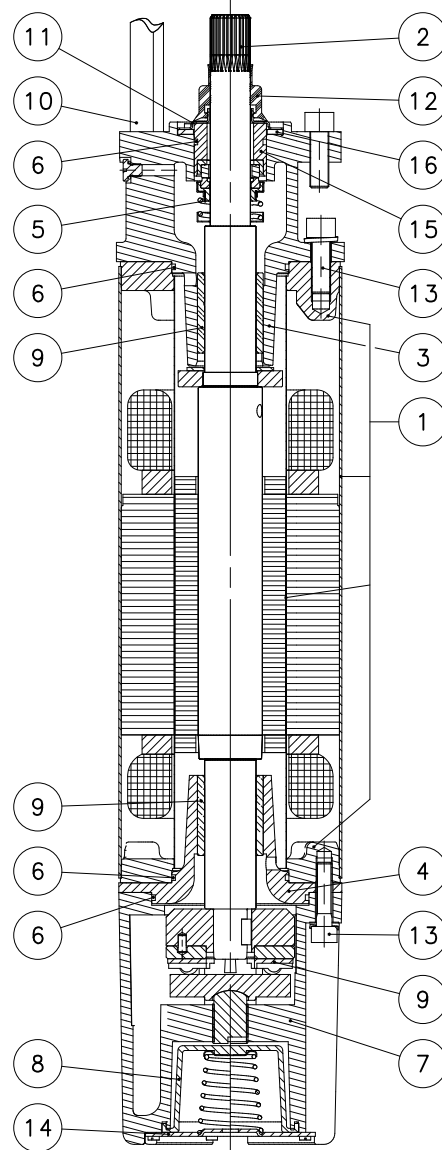

02026_B_DS

REF. N°	PART	MATERIAL	DESIGNATION	
			EUROPE	USA
1	Inner and outer sleeve	Stainless steel	EN 10088-1-X2CrNi18-9 (1.4307)	AISI 304L
	Flanges	Carbon steel	EN 10025 - S355JR (Fe 510-B)	ASTM A105
2	Shaft extension	Stainless steel duplex	EN 10095 X3CrNiMoN27-5-2 (1.4460)	AISI 329
3	Upper bracket	Cast iron	EN 1561-EN-GJL-200 (EN-JL1030)	Class 25 B
4	Intermediate bracket	Cast iron	EN 1561-EN-GJL-200 (EN-JL1030)	Class 25 B
5	Mechanical seal	Aluminium oxide / Carbon-graphite		
6	Elastomers	NBR		
7	Lower bracket	Cast iron	EN 1561-EN-GJL-200 (EN-JL1030)	Class 25 B
8	Compensating bellows	NBR		
9	Bearings	Carbon-graphite		
10	Cable	EPDM		
11	Fixed sand guard	Stainless steel	EN 10088-1-X5CrNi18-10 (1.4301)	AISI 304
12	Removable sand guard	NBR		
13	Bolts and screws	Stainless steel	EN 10088-1-X5CrNi18-10 (1.4301)	AISI 304
14	Lower cover	Stainless steel	EN 10088-1-X5CrNi18-10 (1.4301)	AISI 304
15	Mechanical seal spacer	Carb. steel (nichel-plate)	EN 10025 - S355JR (Fe 510-B)	ASTM A105
16	Sand guard gasket	CR neoprene		
-	Cooling liquid	Demineralized water + antifreeze		

**G6C SERIES
IDENTIFICATION CODE**

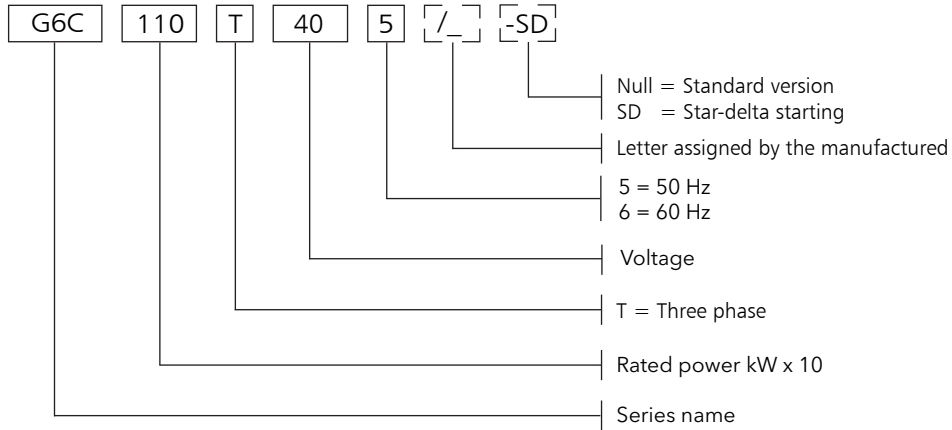

EXAMPLE: G6C110T405

G6C = Motor series G6C
110 = Rated power 11 kW
T = Three-phase
40 = Voltage 380-415 V
5 = Frequency 50 Hz.

RATING PLATE

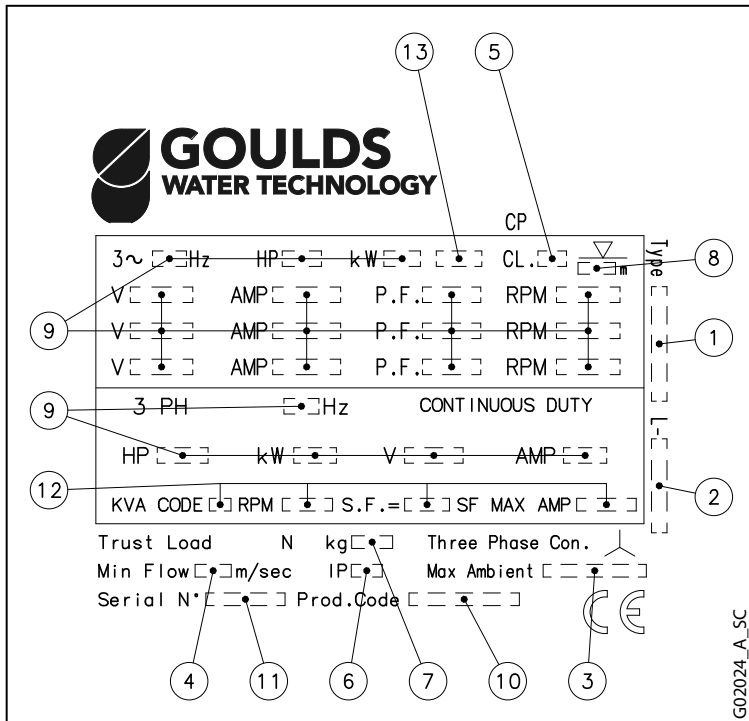

LEGEND

- 1 - Motor type
- 2 - Code
- 3 - Maximum water temperature
- 4 - Minimum water velocity
- 5 - Insulation class
- 6 - Protection class
- 7 - Weight
- 8 - Maximum immersion depth
- 9 - Operating characteristics
- 10 - Production date
- 11 - Serial number
- 12 - Characteristics at service factor
- 13 - Service type

G6C MOTOR SERIES
DIMENSIONS AND WEIGHTS AT 50 Hz

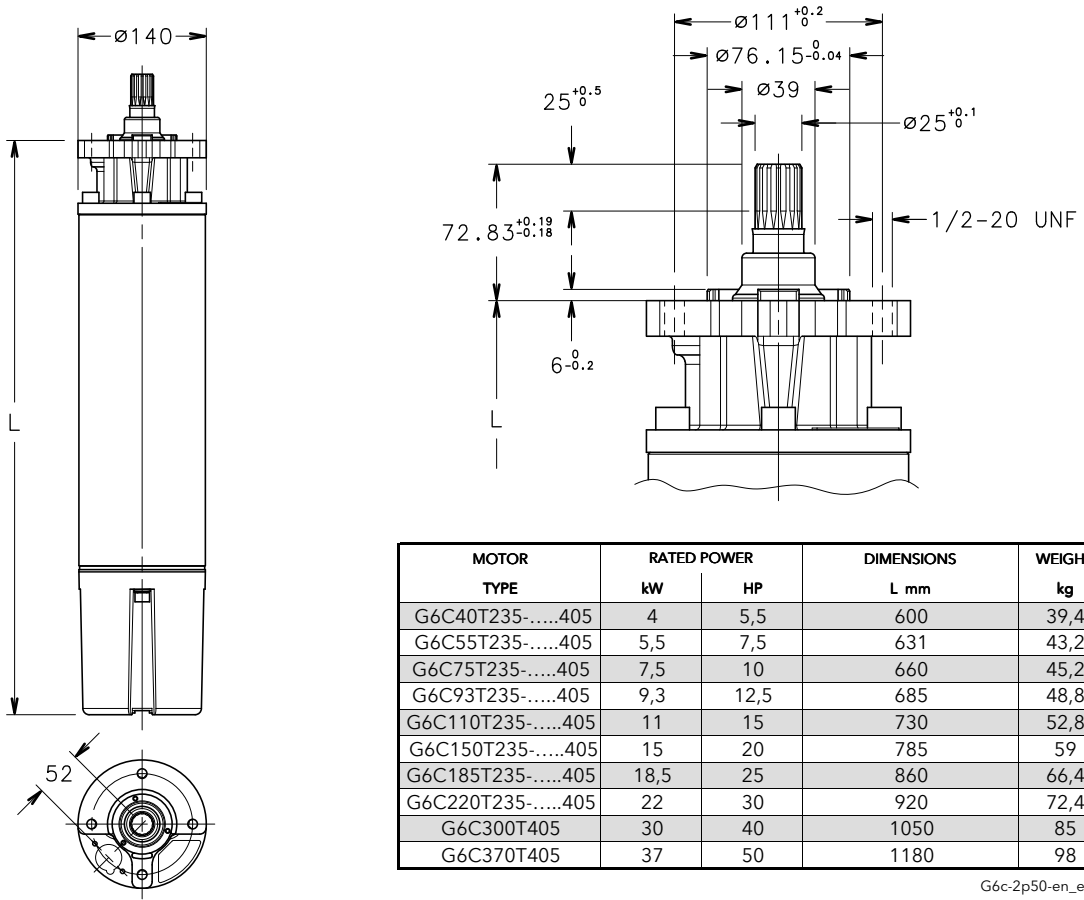

02027_C_DD

G6C MOTOR SERIES THREE-PHASE OPERATING CHARACTERISTICS AT 50 Hz

MOTOR TYPE	RATED POWER		RATED VOLTAGE	RATED CURRENT	OPERATING CHARACTERISTICS AT RATED POWER			DIRECT STARTING		MAX WATER TEMPERATURE °C	CABLE TYPE (FLAT)		
	kW	HP			V	A	rpm	η %	$\cos\phi$		Ts/Tn	Is/In	D.O.L. 4G...
G6C40T235	4	5,5	220	17,8	2825	75	0,80	1,7	3,9	35	4	4	4
			230	18,4	2845	74	0,75	1,7	3,9				
			240	19,1	2860	74	0,70	1,7	3,8				
G6C55T235	5,5	7,5	220	24,1	2820	77	0,80	1,8	3,8	35	4	4	4
			230	24,2	2845	76	0,75	1,8	3,8				
			240	25,3	2860	76	0,71	1,8	3,6				
G6C75T235	7,5	10	220	30,5	2820	78	0,82	2	3,9	35	4	4	4
			230	31,2	2840	77	0,78	2	3,9				
			240	31,7	2850	77	0,73	2	4				
G6C93T235	9,3	12,5	220	37,6	2820	78	0,82	2,1	3,8	35	6	4	4
			230	38,1	2840	79	0,80	2,1	3,9				
			240	39,5	2850	78	0,79	2,15	3,9				
G6C110T235	11	15	220	43,3	2815	77	0,87	2,1	4,5	35	6	4	4
			230	44,2	2840	78	0,82	2,1	4,5				
			240	45,0	2845	77	0,79	2,15	4,5				
G6C150T235	15	20	220	58,0	2810	80	0,84	2,2	4,1	35	6	4	4
			230	57,9	2840	81	0,80	2,2	4,1				
			240	59,2	2850	81	0,76	2,25	4,1				
G6C185T235	18,5	25	220	70,1	2820	81	0,83	2,3	4,3	35	8	4	4
			230	71,0	2845	82	0,80	2,3	4,3				
			240	72,7	2855	82	0,73	2,35	4,3				
G6C220T235	22	30	220	82,3	2810	81	0,88	2,3	4	35	8	6	4
			230	81,4	2825	82	0,84	2,3	4,1				
			240	82,3	2835	82	0,80	2,35	4,2				
G6C40T405	4	5,5	380	10,3	2825	75	0,80	1,7	3,9	35	4	4	4
			400	10,6	2845	74	0,75	1,7	3,9				
			415	11,0	2860	74	0,70	1,7	3,8				
G6C55T405	5,5	7,5	380	13,9	2820	77	0,80	1,8	3,8	35	4	4	4
			400	14,0	2845	76	0,75	1,8	3,8				
			415	14,6	2860	76	0,71	1,8	3,6				
G6C75T405	7,5	10	380	17,6	2820	78	0,82	2	3,9	35	4	4	4
			400	18,0	2840	77	0,78	2	3,9				
			415	18,3	2850	77	0,73	2	4				
G6C93T405	9,3	12,5	380	21,7	2820	78	0,82	2,1	3,8	35	4	4	4
			400	22,0	2840	79	0,80	2,1	3,9				
			415	22,8	2850	78	0,79	2,15	3,9				
G6C110T405	11	15	380	25,0	2815	77	0,87	2,1	4,5	35	4	4	4
			400	25,5	2840	78	0,82	2,1	4,5				
			415	26,0	2845	77	0,79	2,15	4,5				
G6C150T405	15	20	380	33,5	2810	80	0,84	2,2	4,1	35	4	4	4
			400	33,4	2840	81	0,80	2,2	4,1				
			415	34,2	2850	81	0,76	2,25	4,1				
G6C185T405	18,5	25	380	40,5	2820	81	0,83	2,3	4,3	35	6	4	4
			400	41,0	2845	82	0,80	2,3	4,3				
			415	42,0	2855	82	0,73	2,35	4,3				
G6C220T405	22	30	380	47,5	2810	81	0,88	2,3	4	35	6	4	4
			400	47,0	2825	82	0,84	2,3	4,1				
			415	47,5	2835	82	0,80	2,35	4,2				
G6C300T405	30	40	380	63,0	2810	82	0,89	2,4	4	35	8	4	4
			400	61,5	2830	82	0,85	2,4	4,1				
			415	63,5	2840	81	0,80	2,45	3,9				
G6C370T405	37	50	380	79,5	2820	82	0,87	2	3,7	35	8	6	4
			400	79,3	2830	81	0,84	2,2	3,9				
			415	80,0	2840	81	0,80	2,3	4				

Ts/Tn = ratio between starting torque and nominal torque.

Is/In = ratio between starting current and nominal current

G6c-2p50_en_g_te

6" Submersible motors G6W Series

Submersible water filled rewindable motors.



- **Rewindable stator**
- **Mechanical seal**
- **Kingsbury type thrust bearing**
- **Screws to fix the pump are included**
- **Approvals:**
 - ACS
 - D.M. 174/2004

SPECIFICATIONS

- Stainless steel outer sleeve.
- Shaft extension and coupling dimensions to **NEMA** standards.
- **Class insulation:**
70 for standard version.
85 for HT version.
- **Protection class:**
IP68.
- Internal fluid suitable for contact with foodstuffs.
- Strong and durable compensating bellows.
- Axial load supported by angular bearings.
- Mechanical seal protected by sand guard.
- **Maximum immersion depth:**
350 m.
- Suitable for both vertical / horizontal installations
- **Maximum number of starts per hour at regular intervals:**
15.
- **Maximum water temperature:**
30°C for standard version
45°C for HT version
Max. temperature applies to motors working in a installation capable of delivering a flow of water around the motor jacket as following:
 - 0,2 m/s for version:
 - standard from 4 to 9,3 kW
 - HT from 4 to 7,5 kW
 - 0,3 m/s for version:
 - standard from 11 to 30 kW
 - HT from 9,3 to 26 kW
 - 0,5 m/s for version:
 - standrad from 37 kW
 - HT from 30 kW.

• Axial thrust:

16000 N from 4 to 22 kW;
30000 N from 26 to 37 kW.

• Version:

Three-phase:
from 4 to 37 kW
380-415 V ± 6% 50 Hz

OPTIONAL FEATURES

- Silicon Carbide mechanical seal.
- **G6WN** version made of stainless steel.
- **G6WR** version made of Duplex stainless steel.
- **HT** version for high temperature.
- Different voltages and frequencies
- Motors with double cable outlet for star/delta start can be supplied upon request.

For application limits, refer to technical appendix chapter

ACCESSORIES

- Temperature sensor **PT 100 / PTC.**
- Control panels.
- Drop cables
- Coupling flange.
- Cooling sleeve.

**G6W - G6WN - G6WR MOTOR SERIES
MOTOR CROSS SECTION**

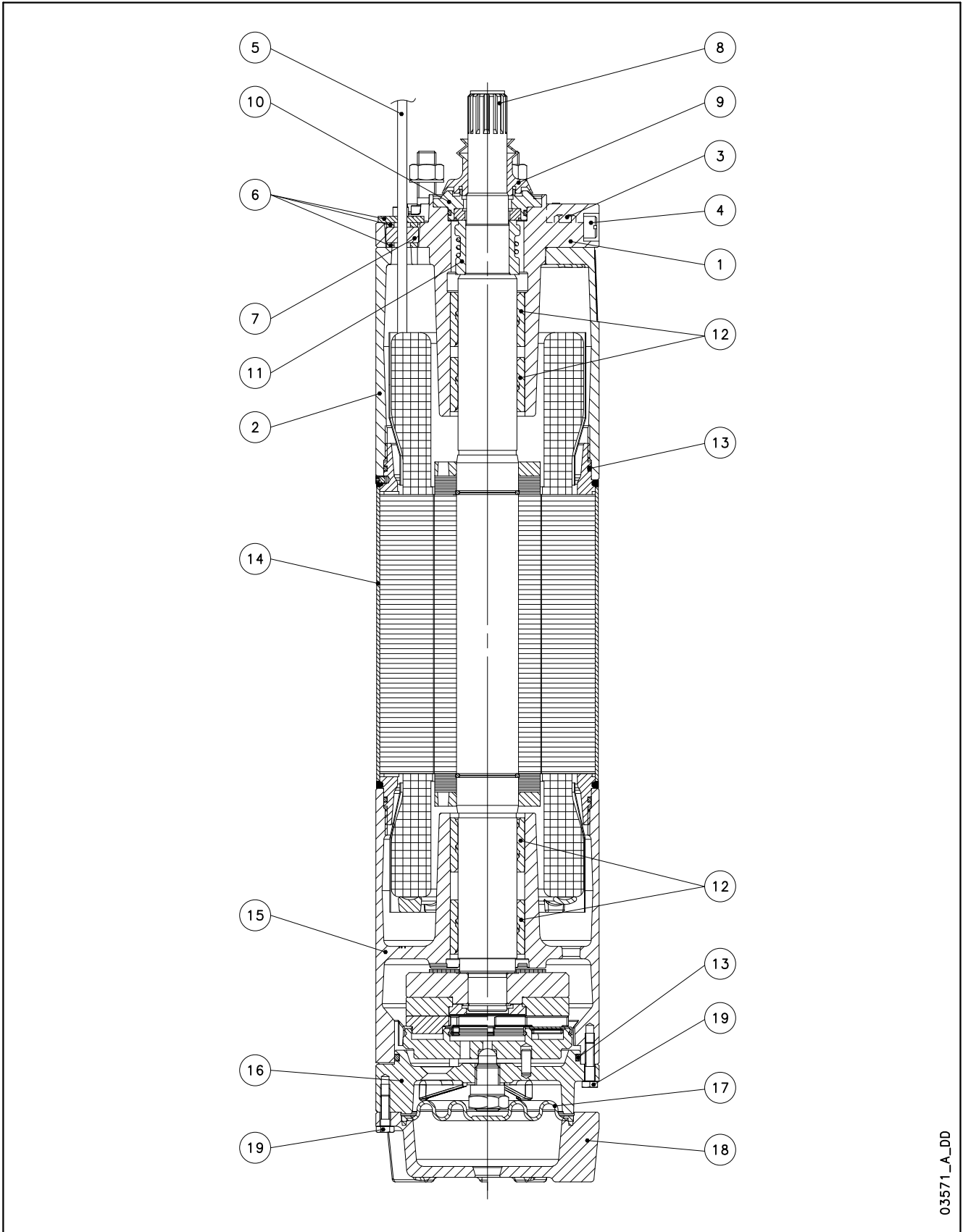

03571_A_DD

G6W TABLE OF MATERIALS

REF. N°	PART	MATERIAL	DESIGNATION	
			EUROPE	USA
1	Upper bracket	Cast iron	EN 1561-EN-GJL-200 (EN-JL1030)	Class 25 B
2	Spacer	Cast iron	EN 1561-EN-GJL-200 (EN-JL1030)	Class 25 B
3	Filling plug (+OR)	Stainless steel	EN 10088-1-X5CrNiMo17-12-2 (1.4401)	AISI 316
4	Vent valve	Stainless steel	EN 10088-1-X5CrNiMo17-12-2 (1.4401)	AISI 316
5	Cable	EPR		
6	Cable gland plate	Stainless steel	EN 10088-1-X5CrNi18-10 (1.4301)	AISI304
7	Cable gland	EPDM		
8	Shaft end	Stainless steel	EN 10088-1-X20Cr13 (1.4021)	AISI420
9	Removable sand guard	EPDM		
10	Mechanical seal cover	Stainless steel	EN 10213-4-GX5CrNi19-10 (1.4308)	ASTM CF-8 (AISI 304 cast)
11	Mechanical seal	Carbon-graphite / Ceramic		
12	Bush bearings	Carbon-graphite		
13	Elastomers	NBR		
14	Motor sleeve	Stainless steel	EN 10088-1-X2CrNi19-11 (1.4306)	AISI304L
15	Lower bracket	Cast iron	EN 1561-EN-GJL-200 (EN-JL1030)	Class 25 B
16	Thrust bearing bracket	Cast iron	EN 1561-EN-GJL-200 (EN-JL1030)	Class 25 B
17	Diaphragm	EPDM		
18	Lower cover	Cast iron	EN 1561-EN-GJL-200 (EN-JL1030)	Class 25 B
19	Bolts and screws	Stainless steel	EN 10088-1-X5CrNi18-10 (1.4301)	AISI304
-	Cooling liquid	Water + antifreeze		

L6w-2p50-en_c_tm

G6WN TABLE OF MATERIALS

REF. N°	PART	MATERIAL	DESIGNATION	
			EUROPE	USA
1	Upper bracket	Stainless steel	EN 10213-4-GX5CrNiMo19-11-2 (1.4408)	ASTM CF-8M (AISI 316 cast)
2	Spacer	Stainless steel	EN 10213-4-GX5CrNiMo19-11-2 (1.4408)	ASTM CF-8M (AISI 316 cast)
3	Filling plug (+OR)	Stainless steel (+NBR)	EN 10088-1-X5CrNiMo17-12-2 (1.4401)	AISI 316
4	Vent valve	Stainless steel	EN 10088-1-X5CrNiMo17-12-2 (1.4401)	AISI 316
5	Cable	EPR		
6	Cable gland plate	Stainless steel	EN 10088-1-X5CrNiMo17-12-2 (1.4401)	AISI 316
7	Cable seal	EPDM		
8	Shaft end	Duplex stainless steel	EN 10088-1-X2CrNiMoN22-5-3 (1.4462)	A276/A790-S31803
9	Removable sand guard	EPDM		
10	Mechanical seal cover	Stainless steel	EN 10213-4-GX5CrNiMo19-11-2 (1.4408)	ASTM CF-8M (AISI 316 cast)
11	Mechanical seal	Carbon graphite / Ceramic		
12	Bush bearings	Carbon-graphite		
13	Elastomers	NBR		
14	Motor sleeve	Stainless steel	EN 10088-1-X2CrNiMo17-12-2 (1.4404)	AISI 316L
15	Lower bracket	Stainless steel	EN 10213-4-GX5CrNiMo19-11-2 (1.4408)	ASTM CF-8M (AISI 316 cast)
16	Thrust bearing bracket	Stainless steel	EN 10213-4-GX5CrNiMo19-11-2 (1.4408)	ASTM CF-8M (AISI 316 cast)
17	Diaphragm	EPDM		
18	Lower cover	Stainless steel	EN 10213-4-GX5CrNiMo19-11-2 (1.4408)	ASTM CF-8M (AISI 316 cast)
19	Bolts and screws	Stainless steel	EN 10088-1-X5CrNiMo17-12-2 (1.4401)	AISI 316
-	Cooling liquid	Water + antifreeze		

L6wn-2p50-en_c_tm

G6WR TABLE OF MATERIALS

REF. N°	PART	MATERIALE	DESIGNATION	
			EUROPE	USA
1	Upper bracket	Duplex stainless steel	EN 10213-4-GX2CrNiMoCuN25-6-3-3 (1.4517)	
2	Spacer	Duplex stainless steel	EN 10213-4-GX2CrNiMoCuN25-6-3-3 (1.4517)	
3	Filling plug (+OR)	Duplex stainless steel + NBR	EN 10088-1-X2CrNiMoN22-5-3 (1.4462)	A276/A790-S31803
4	Vent valve	Duplex stainless steel	EN 10088-1-X2CrNiMoN22-5-3 (1.4462)	A276/A790-S31803
5	Cable	EPR		
6	Cable gland plate	Stainless steel	EN 10088-1X1NiCrMoCu25-20-5 (1.4539)	AISI 904L
7	Cable gland	EPDM		
8	Shaft end	Duplex stainless steel	EN 10088-1-X2CrNiMoN22-5-3 (1.4462)	A276/A790-S31803
9	Removable sand guard	EPDM		
10	Mechanical seal cover	Duplex stainless steel	EN 10088-1-X2CrNiMoN22-5-3 (1.4462)	A276/A790-S31803
11	Mechanical seal	Carbon graphite / Ceramic		
12	Bush bearings	Carbon-graphite		
13	Elastomers	NBR		
14	Motor sleeve	Stainless steel	EN 10088-1X1NiCrMoCu25-20-5 (1.4539)	AISI 904L
15	Lower bracket	Duplex stainless steel	EN 10213-4-GX2CrNiMoCuN25-6-3-3 (1.4517)	
16	Thrust bearing bracket	Duplex stainless steel	EN 10213-4-GX2CrNiMoCuN25-6-3-3 (1.4517)	
17	Diaphragm	EPDM		
18	Lower cover	Duplex stainless steel	EN 10213-4-GX2CrNiMoCuN25-6-3-3 (1.4517)	
19	Bolts and screws	Duplex stainless steel	EN 10088-1-X2CrNiMoN22-5-3 (1.4462)	A276/A790-S31803
-	Cooling liquid	Water + antifreeze		

L6wr-2p50-en_c_tm

G6W MOTOR SERIES IDENTIFICATION CODE

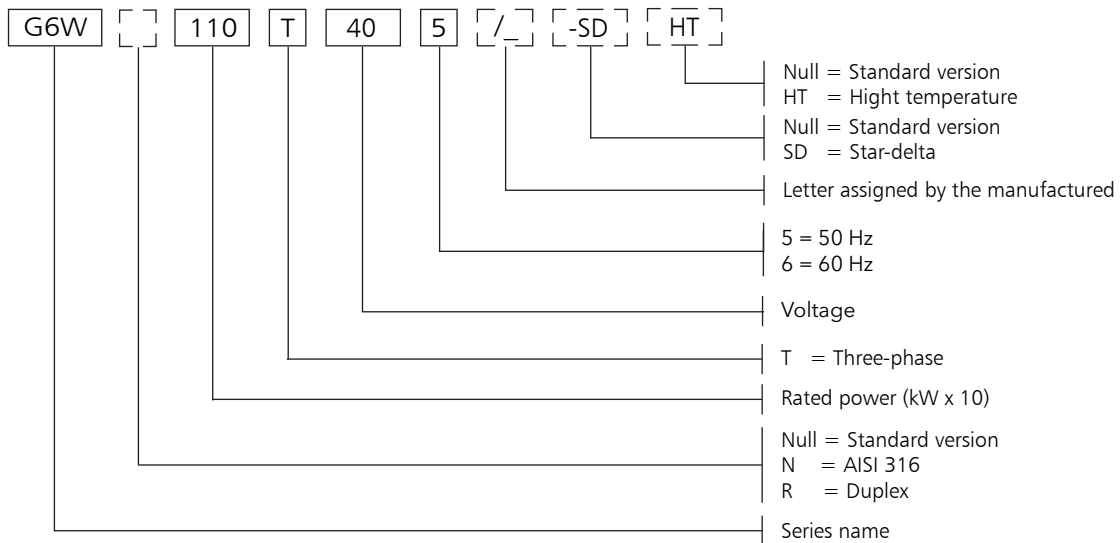

EXAMPLE: G6W110T405/A HT

G6W = Motor series G6W
110 = Rated power 11 kW
T = Three-phase
40 = Voltage 380-415 V
5 = Frequency 50 Hz.
HT = high temperature.

RATING PLATE

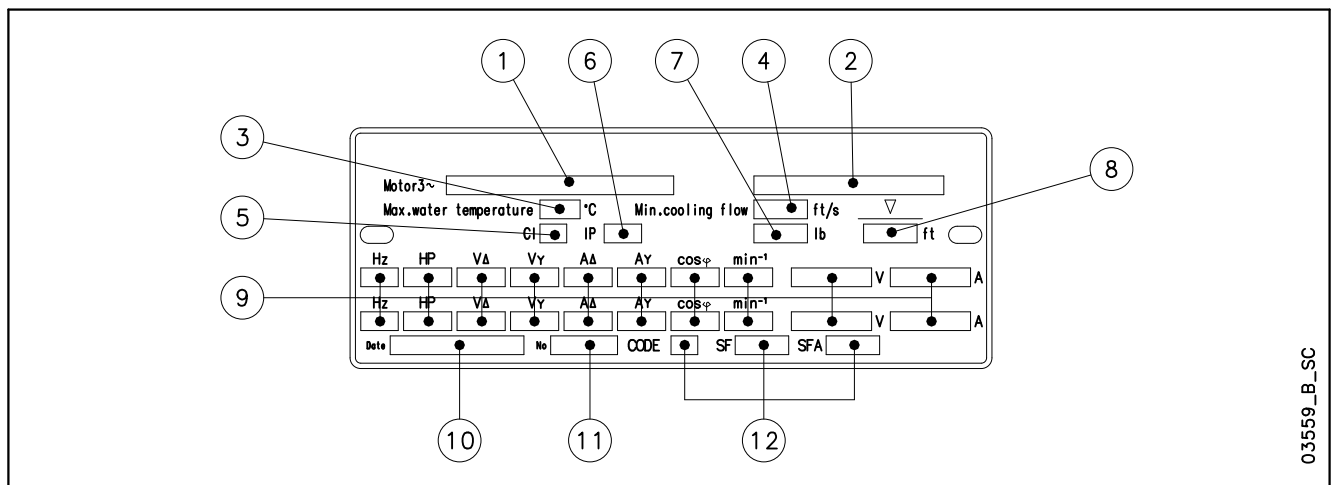

03559_B_SC

LEGEND

- 1 - Motor type
- 2 - Code
- 3 - Maximum water temperature
- 4 - Minimum water velocity
- 5 - Insulation class
- 6 - Protection class
- 7 - Weight
- 8 - Maximum immersion depth
- 9 - Operating characteristics
- 10 - Production date
- 11 - Serial number
- 12 - Characteristics at service factor

**G6W MOTOR SERIES
DIMENSIONS AND WEIGHTS AT 50 Hz**

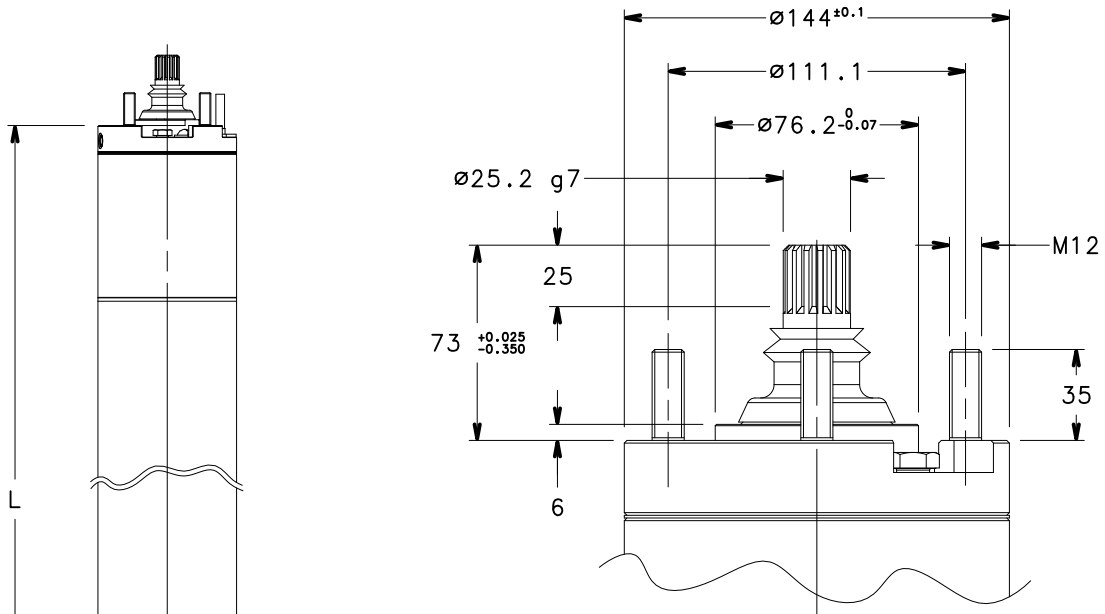

MOTOR TYPE	RATED POWER		DIMENSIONS mm L	WEIGHT kg
	kW	HP		
G6W40T405	4	5,5	583	38
G6W55T405	5,5	7,5	613	42
G6W75T405	7,5	10	653	46
G6W93T405	9,3	12,5	683	50
G6W110T405	11	15	723	54
G6W130T405	13	17,5	763	58
G6W150T405	15	20	833	66
G6W185T405	18,5	25	903	74
G6W220T405	22	30	943	77
G6W260T405	26	35	1071	86
G6W300T405	30	40	1151	94
G6W370T405	37	50	1301	108

G6w-2p50-en_a_td

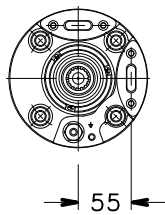

MOTOR TYPE	RATED POWER		DIMENSIONS mm L	WEIGHT kg
	kW	HP		
G6W40T405 HT	4	5,5	613	42
G6W55T405 HT	5,5	7,5	653	46
G6W75T405 HT	7,5	10	683	50
G6W93T405 HT	9,3	12,5	723	54
G6W110T405 HT	11	15	763	58
G6W130T405 HT	13	17,5	833	66
G6W150T405 HT	15	20	903	74
G6W185T405 HT	18,5	25	943	77
G6W220T405 HT	22	30	1071	86
G6W260T405 HT	26	35	1151	94
G6W300T405 HT	30	40	1301	108

G6w-ht-2p50-en_a_td

03570_D_DD

G6W MOTOR SERIES THREE-PHASE OPERATING CHARACTERISTICS AT 50 Hz

MOTOR TYPE	RATED POWER		RATED VOLTAGE V	RATED CURRENT A	OPERATING CHARACTERISTICS AT RATED POWER			DIRECT STARTING		MAX WATER TEMP. °C	CABLE TYPE (FLAT)		
	THREE-PHASE kW	HP			rpm	η %	$\cos\varphi$	Ts/Tn	Is/In		D.O.L. 4G...	Y/D 4G..+3x.. mm ²	L m
G6W40T405	4	5,5	380	9,89	2835	68,1	0,90	1,00	3,56	30	4	-	4
			400	9,26	2865	71,0	0,88	1,13	4,00				
			415	9,13	2880	71,5	0,85	1,21	4,20				
G6W55T405	5,5	7,5	380	12,7	2855	75,4	0,88	1,18	4,37	30	4	4	4
			400	12,4	2875	75,7	0,85	1,31	4,70				
			415	12,5	2885	75,4	0,82	1,42	4,85				
G6W75T405	7,5	10	380	17,0	2840	74,9	0,90	1,26	4,34	30	4	4	4
			400	16,4	2860	76,0	0,87	1,41	4,74				
			415	16,2	2875	76,5	0,84	1,52	4,96				
G6W93T405	9,3	12,5	380	20,5	2840	77,6	0,89	1,51	4,64	30	4	4	4
			400	20,0	2860	78,2	0,86	1,68	5,01				
			415	19,9	2870	78,3	0,83	1,81	5,21				
G6W110T405	11	15	380	24,2	2830	77,2	0,90	1,44	4,38	30	4	4	4
			400	23,5	2850	78,0	0,87	1,47	4,75				
			415	23,4	2865	78,0	0,84	1,73	4,94				
G6W130T405	13	17,5	380	28,1	2830	77,9	0,90	1,31	4,53	30	4	4	4
			400	27,1	2855	78,9	0,88	1,47	4,93				
			415	27,0	2865	79,1	0,90	1,59	5,15				
G6W150T405	15	20	380	32,1	2830	80,2	0,88	1,55	4,88	30	4	4	4
			400	31,5	2855	80,6	0,85	1,72	5,25				
			415	31,3	2865	80,9	0,82	1,86	5,46				
G6W185T405	18,5	25	380	38,5	2845	81,8	0,89	1,77	5,23	30	6	4	4
			400	37,6	2860	82,4	0,86	1,97	5,65				
			415	37,5	2870	82,4	0,83	2,13	5,86				
G6W220T405	22	30	380	47,3	2865	81,7	0,87	0,86	4,60	30	6	4	4
			400	46,5	2880	82,2	0,83	0,96	4,93				
			415	46,7	2890	82,2	0,8	1,04	5,09				
G6W260T405	26	35	380	56,5	2860	81,9	0,85	1,58	4,82	30	6	4	4
			400	55,4	2880	82,7	0,82	1,76	5,18				
			415	55,7	2890	82,7	0,79	1,90	5,35				
G6W300T405	30	40	380	63,8	2870	82,3	0,87	1,07	4,94	30	10	4	4
			400	62,3	2890	83,1	0,84	1,19	5,32				
			415	62,0	2900	83,3	0,81	1,29	5,55				
G6W370T405	37	50	380	81,8	2845	79,6	0,86	1,03	4,25	30	10	4	4
			400	79,1	2870	81,2	0,83	1,15	4,63				
			415	79,4	2880	80,8	0,80	1,25	4,79				

Ts/Tn = ratio between starting torque and nominal torque.

Is/In = ratio between starting current and nominal current

G6w-2p50-en_a_te

G6W HT MOTOR SERIES THREE-PHASE OPERATING CHARACTERISTICS AT 50 Hz

MOTOR TYPE THREE-PHASE	RATED POWER		RATED VOLTAGE V	RATED CURRENT A	OPERATING CHARACTERISTICS AT RATED POWER			DIRECT STARTING		MAX WATER TEMPERATURE °C	CABLE TYPE (FLAT)		
	kW	HP			rpm	η %	$\cos\phi$	Ts/Tn	Is/In		D.O.L. 4G...	Y/D 4G..+3x.. mm ²	L m
G6W40T405 HT	4	5,5	380	9,81	2905	76,9	0,81	1,65	5,65	45	4	4	4
			400	10,1	2915	75,5	0,76	1,83	5,78				
			415	10,5	2920	74,2	0,72	1,98	5,77				
G6W55T405 HT	5,5	7,5	380	12,9	2895	77,1	0,84	1,75	5,71	45	4	4	4
			400	13,0	2905	77,0	0,79	1,95	5,96				
			415	13,4	2915	76,3	0,75	2,10	6,03				
G6W75T405 HT	7,5	10	380	16,9	2880	79,2	0,85	1,89	5,64	45	4	4	4
			400	16,9	2890	79,0	0,81	2,11	5,91				
			415	17,3	2900	78,3	0,77	2,27	6,00				
G6W93T405 HT	9,3	12,5	380	20,6	2865	79,2	0,87	1,72	5,13	45	4	4	4
			400	20,4	2880	79,3	0,83	1,82	5,44				
			415	20,8	2890	78,4	0,79	2,07	5,53				
G6W110T405 HT	11	15	380	23,8	2870	80,1	0,88	1,57	5,35	45	4	4	4
			400	23,6	2885	80,1	0,84	1,75	5,69				
			415	23,9	2890	79,8	0,80	1,89	5,83				
G6W130T405 HT	13	17,5	380	28,3	2860	81,8	0,85	1,80	5,55	45	4	4	4
			400	28,1	2875	81,4	0,82	2,01	5,87				
			415	28,4	2885	81,4	0,78	2,17	6,03				
G6W150T405 HT	15	20	380	31,8	2880	83,6	0,86	2,21	6,33	45	6	4	4
			400	31,9	2890	83,4	0,82	2,46	6,65				
			415	32,5	2900	82,8	0,78	2,65	6,77				
G6W185T405 HT	18,5	25	380	40,3	2895	83,9	0,83	1,04	5,40	45	6	4	4
			400	40,5	2905	83,5	0,79	1,15	5,65				
			415	41,6	2910	83,0	0,75	1,24	5,71				
G6W220T405 HT	22	30	380	48,5	2890	83,6	0,82	1,89	5,62	45	6	4	4
			400	48,6	2905	83,6	0,78	2,10	5,90				
			415	49,7	2910	83,2	0,74	2,26	5,99				
G6W260T405 HT	26	35	380	55,7	2895	83,8	0,85	1,24	5,66	45	10	4	4
			400	55,2	2905	84,0	0,81	1,38	6,00				
			415	55,8	2915	83,9	0,77	1,49	6,17				
G6W300T405 HT	30	40	380	67,1	2885	82,2	0,83	1,29	5,18	45	10	4	4
			400	67,1	2900	82,8	0,78	1,44	5,46				
			415	68,8	2910	81,8	0,74	1,55	5,52				

Ts/Tn = ratio between starting torque and nominal torque.

Is/In = ratio between starting current and nominal current

G6w-ht-2p50-en_a_te

8" Submersible motors G8W Series

Submersible water filled rewindable motors.



- **Rewindable stator**
- **Mechanical seal**
- **Kingsbury type thrust bearing**
- **Approvals:**
 - ACS
 - D.M. 174/2004

SPECIFICATIONS

- Stainless steel outer sleeve.
- Shaft extension and coupling dimensions to **NEMA** standards.
- **Class insulation:**
70 for standard version.
85 for HT version.
- **Protection class:**
IP68.
- Internal fluid suitable for contact with foodstuffs.
- Strong and durable compensating bellows.
- Axial load supported by angular bearings.
- Mechanical seal protected by sand guard.
- **Maximum immersion depth:**
350 m.
- Suitable for both vertical / horizontal installations
- **Maximum number of starts per hour at regular intervals:**
10 .
- **Maximum water temperature:**
30°C for standard version
45°C for HT version
Max. temperature applies to motors working in a installation capable of delivering a flow of water around the motor jacket of at least 0,5 m/s.
- **Axial thrust:**
50000 N from 30 to 93 kW.
- **Version:**
Three-phase:
from 30 to 93 kW
380-415 V ± 6% 50 Hz

OPTIONAL FEATURES

- Silicon Carbide mechanical seal.
- **G8WN** version made of stainless steel.
- **G8WR** version made of Duplex stainless steel
- **HT** version for high temperature.
- Different voltages and frequencies.
- Motors with double cable outlet for star/delta start can be supplied upon request.

For application limits, refer to technical appendix chapter.

ACCESSORIES

- Temperature sensor **PT 100 / PTC.**
- Control panels.
- Drop cables
- Coupling flange.
- Cooling sleeve.
- Screws to fix the pump.

**G8W - G8WN - G8WR MOTOR SERIES
 MOTOR CROSS SECTION**

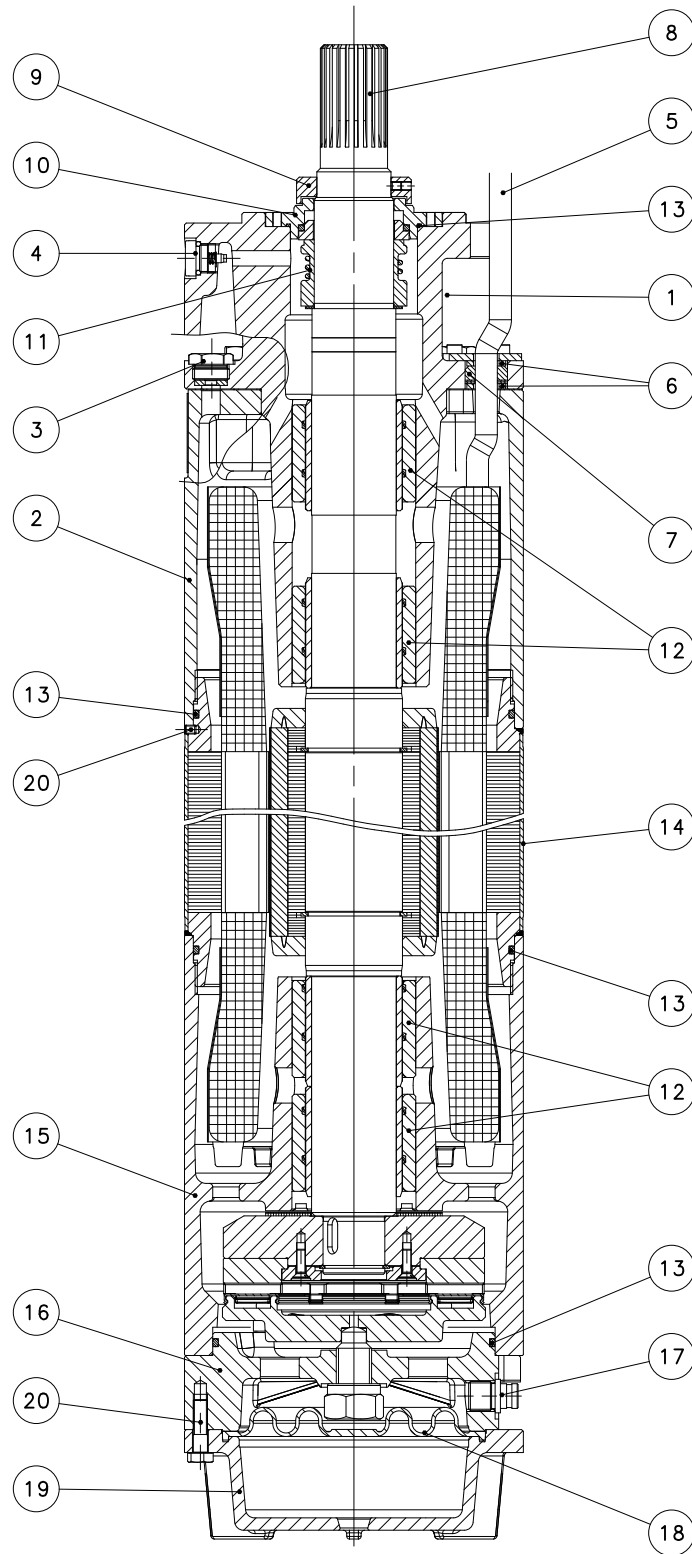

03572_B_DS

G8W TABLE OF MATERIALS

REF. N°	PART	MATERIAL	DESIGNATION	
			EUROPE	USA
1	Upper bracket	Cast iron	EN 1561-EN-GJL-200 (EN-JL1030) Class 25 B	
2	Spacer	Cast iron	EN 1561-EN-GJL-200 (EN-JL1030) Class 25 B	
3	Filling plug (+OR)	Stainless steel (+NBR)	EN 10088-1-X5CrNiMo17-12-2 (1.4401) AISI 316	
4	Vent valve	Stainless steel	EN 10088-1-X5CrNiMo17-12-2 (1.4401) AISI 316	
5	Cable	EPR		
6	Cable gland plate	Stainless steel	EN 10088-1-X5CrNi18-10 (1.4301) AISI 304	
7	Cable gland	EPDM		
8	Shaft end	Duplex stainless steel	EN 10088-1-X2CrNiMoN22-5-3 (1.4462) A276/A790-S31803	
9	Removable sand guard	Stainless steel	EN 10088-1-X2CrNiMo17-12-2 (1.4404) AISI 316L	
10	Mechanical seal cover	Stainless steel	EN 10088-1-X2CrNiMo17-12-2 (1.4404) AISI 316L	
11	Mechanical seal	Carbon-graphite / Ceramic		
12	Bush bearings	Carbon-graphite		
13	Elastomers	NBR		
14	Motor sleeve	Stainless steel	EN 10088-1-X2CrNi19-11 (1.4306) AISI304L	
15	Lower bracket	Cast iron	EN 1561-EN-GJL-200 (EN-JL1030) Class 25 B	
16	Thrust bearing bracket	Cast iron	EN 1561-EN-GJL-200 (EN-JL1030) Class 25 B	
17	Filling valve	Stainless steel	EN 10088-1-X5CrNiMo17-12-2 (1.4401) AISI 316	
18	Diaphragm	EPDM		
19	Lower cover	Cast iron	EN 1561-EN-GJL-200 (EN-JL1030) Class 25 B	
20	Bolts and screws	Stainless steel	EN 10088-1-X5CrNi18-10 (1.4301) AISI 304	
-	Cooling liquid	Water + antifreeze		

L8-L10w-2p50-en_b_tm

G8WN TABLE OF MATERIALS

REF. N°	PART	MATERIAL	DESIGNATION	
			EUROPE	USA
1	Upper bracket	Stainless steel	EN 10213-4 - GX5CrNiMo19-11-2 (1.4408) ASTM CF-8M (AISI 316 cast)	
2	Spacer	Stainless steel	EN 10213-4 - GX5CrNiMo19-11-2 (1.4408) ASTM CF-8M (AISI 316 cast)	
3	Filling plug (+OR)	Stainless steel	EN 10088-1-X5CrNiMo17-12-2 (1.4401) AISI 316	
4	Vent valve	Stainless steel	EN 10088-1-X5CrNiMo17-12-2 (1.4401) AISI 316	
5	Cable	EPR		
6	Cable gland plate	Stainless steel	EN 10088-1-X5CrNiMo17-12-2 (1.4401) AISI 316	
7	Cable gland	EPDM		
8	Shaft end	Duplex stainless steel	EN 10088-1-X2CrNiMoN22-5-3 (1.4462) A276/A790-S31803	
9	Removable sand guard	Stainless steel	EN 10088-1-X2CrNiMo17-12-2 (1.4404) AISI 316L	
10	Mechanical seal cover	Stainless steel	EN 10088-1-X2CrNiMo17-12-2 (1.4404) AISI 316L	
11	Mechanical seal	Carbon-graphite / Aluminium oxide		
12	Bush bearings	Carbon-graphite		
13	Elastomers	NBR		
14	Motor sleeve	Stainless steel	EN 10088-1-X2CrNiMo17-12-2 (1.4404) AISI 316L	
15	Lower bracket	Stainless steel	EN 10213-4 - GX5CrNiMo19-11-2 (1.4408) ASTM CF-8M (AISI 316 cast)	
16	Thrust bearing bracket	Stainless steel	EN 10213-4 - GX5CrNiMo19-11-2 (1.4408) ASTM CF-8M (AISI 316 cast)	
17	Filling valve	Stainless steel	EN 10088-1-X5CrNiMo17-12-2 (1.4401) AISI 316	
18	Diaphragm	EPDM		
19	Lower cover	Stainless steel	EN 10213-4 - GX5CrNiMo19-11-2 (1.4408) ASTM CF-8M (AISI 316 cast)	
20	Bolts and screws	Stainless steel	EN 10088-1-X5CrNiMo17-12-2 (1.4401) AISI 316	
-	Cooling liquid	Water + antifreeze		

L8-L10wn-2p50-en_b_tm

G8WR TABLE OF MATERIALS

REF. N°	PART	MATERIAL	DESIGNATION	
			EUROPE	USA
1	Upper bracket	Duplex stainless steel	EN 10213-4-GX2CrNiMoCuN25-6-3-3 (1.4517)	
2	Spacer	Duplex stainless steel	EN 10213-4-GX2CrNiMoCuN25-6-3-3 (1.4517)	
3	Filling plug (+OR)	Duplex steel (+NBR)	EN 10088-1-X2CrNiMoN22-5-3 (1.4462) A276/A790-S31803	
4	Vent valve	Duplex stainless steel	EN 10088-1-X2CrNiMoN22-5-3 (1.4462) A276/A790-S31803	
5	Cable	EPR		
6	Cable gland plate	Stainless steel	EN 10088-1X1NiCrMoCu25-20-5 (1.4539) AISI 904L	
7	Cable gland	EPDM		
8	Shaft end	Duplex stainless steel	EN 10088-1-X2CrNiMoN22-5-3 (1.4462) A276/A790-S31803	
9	Removable sand guard	Duplex stainless steel	EN 10088-1-X2CrNiMoN22-5-3 (1.4462) A276/A790-S31803	
10	Mechanical seal cover	Duplex stainless steel	EN 10088-1-X2CrNiMoN22-5-3 (1.4462) A276/A790-S31803	
11	Mechanical seal	Carbon-graphite / Aluminium oxide		
12	Bush bearings	Carbon-graphite		
13	Elastomers	NBR		
14	Motor sleeve	Stainless steel	EN 10088-1X1NiCrMoCu25-20-5 (1.4539) AISI 904L	
15	Lower bracket	Duplex stainless steel	EN 10213-4-GX2CrNiMoCuN25-6-3-3 (1.4517)	
16	Thrust bearing bracket	Duplex stainless steel	EN 10213-4-GX2CrNiMoCuN25-6-3-3 (1.4517)	
17	Filling valve	Duplex stainless steel	EN 10088-1-X2CrNiMoN22-5-3 (1.4462) A276/A790-S31803	
18	Diaphragm	EPDM		
19	Lower cover	Duplex stainless steel	EN 10213-4-GX2CrNiMoCuN25-6-3-3 (1.4517)	
20	Bolts and screws	Duplex stainless steel	EN 10088-1-X2CrNiMoN22-5-3 (1.4462) A276/A790-S31803	
-	Cooling liquid	Water + antifreeze		

L8-L10wr-2p50-en_b_tm

G8W MOTOR SERIES IDENTIFICATION CODE

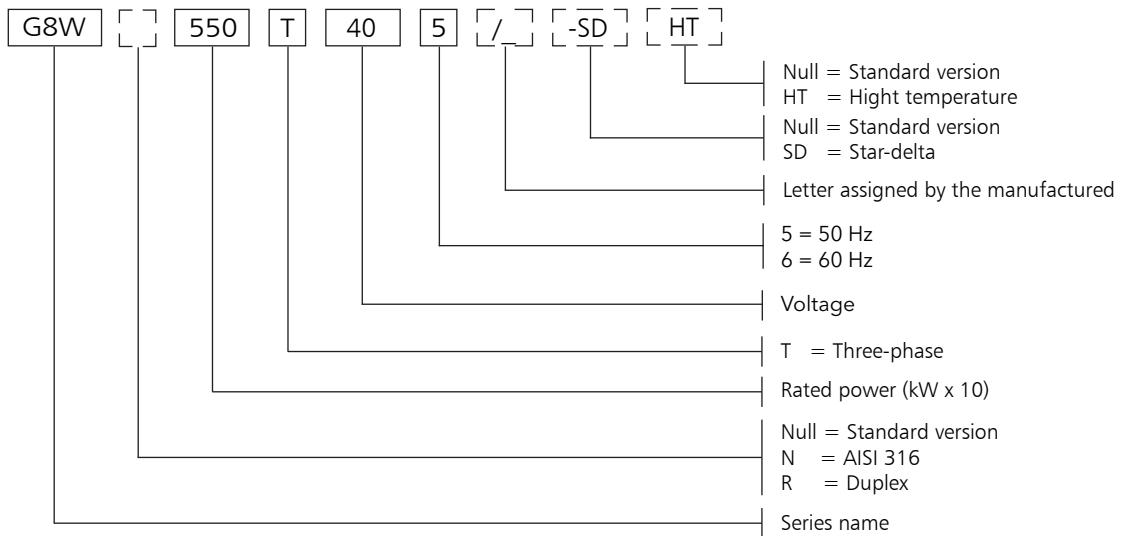

EXAMPLE: G8W550T405/C HT

G8W = Motor series G8W
550 = Rated power 55 kW
T = Three-phase
40 = Voltage 380-415 V
5 = Frequency 50 Hz.
HT = high temperature.

RATING PLATE

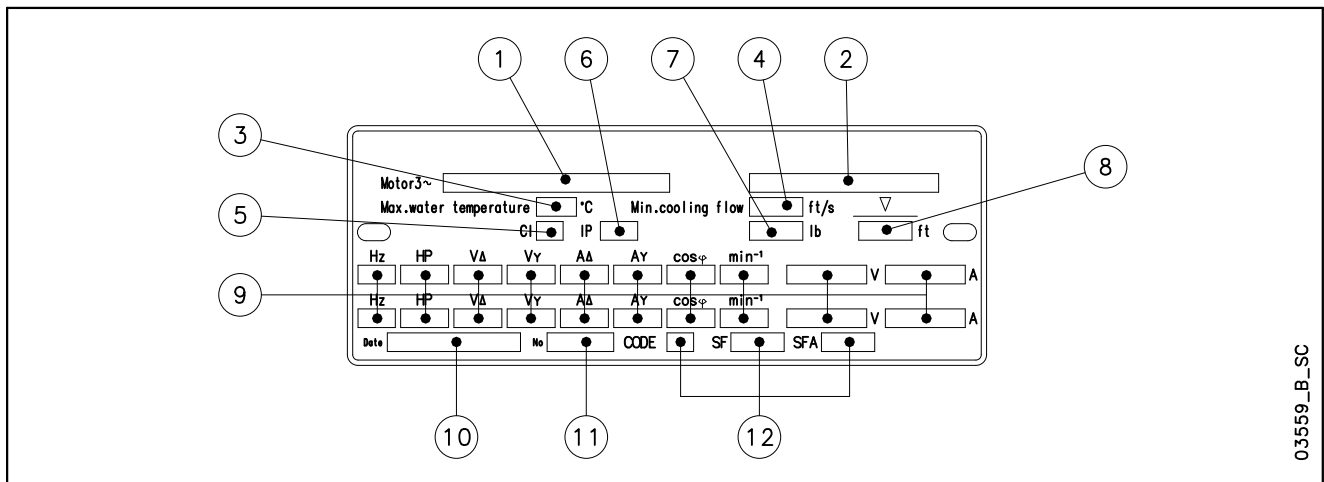

03559_B_SC

LEGEND

- 1 - Motor type
- 2 - Code
- 3 - Maximum water temperature
- 4 - Minimum water velocity
- 5 - Insulation class
- 6 - Protection class
- 7 - Weight
- 8 - Maximum immersion depth
- 9 - Operating characteristics
- 10 - Production date
- 11 - Serial number
- 12 - Characteristics at service factor

**G8W MOTOR SERIES
DIMENSIONS AND WEIGHTS AT 50 Hz**

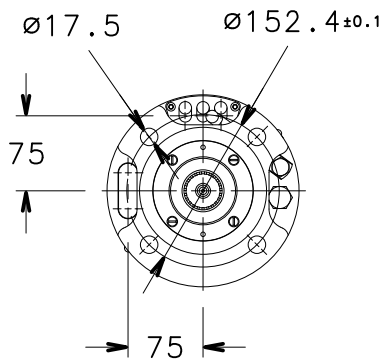
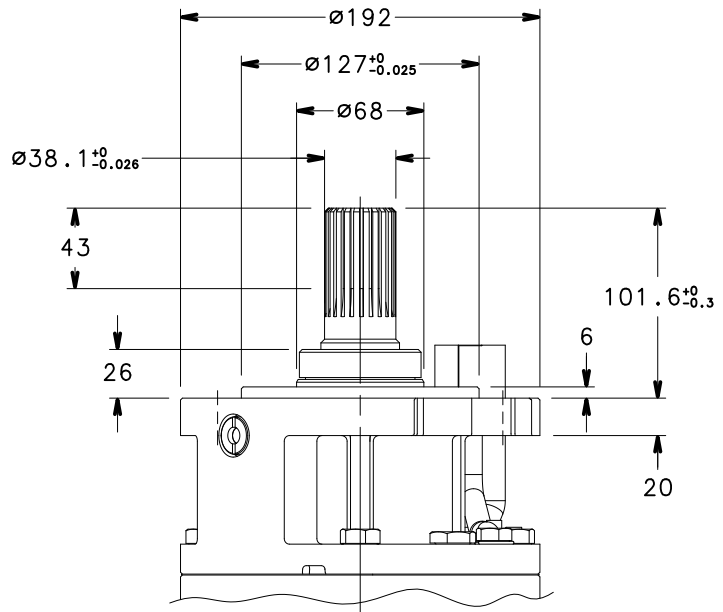
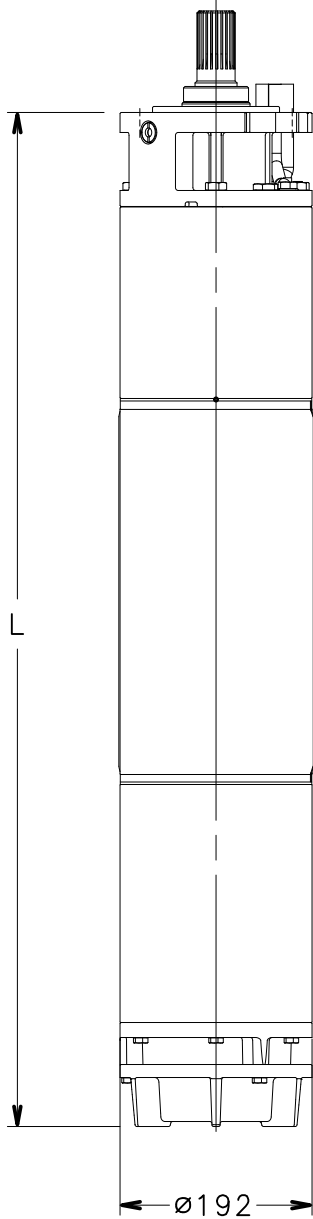

MOTOR TYPE	RATED POWER		DIMENSIONS (mm) L mm	WEIGHT KG
	kW	HP		
G8W300T405/C G8W300T405/C HT	30	40	975	136
G8W370T405/C G8W370T405/C HT	37	50	1055	153
G8W450T405/C G8W450T405/C HT	45	60	1135	170
G8W520T405/C G8W520T405/C HT	52	70	1215	186
G8W550T405/C G8W550T405/C HT	55	75	1245	192
G8W600T405/C G8W600T405/C HT	60	80	1295	203
G8W670T405/C G8W670T405/C HT	67	90	1375	219
G8W750T405/C G8W750T405/C HT	75	100	1465	235
G8W830T405/C G8W830T405/C HT	83	110	1545	250
G8W930T405/C G8W930T405/C HT	93	125	1655	270
G8W1100T405/C G8W1100T405/C HT	110	150	1835	301

G8w_C-2p50-en_a_td

03550_C_DD

G8W MOTOR SERIES THREE-PHASE OPERATING CHARACTERISTICS AT 50 Hz

MOTOR TYPE	RATED POWER		RATED VOLTAGE V	RATED CURRENT A	OPERATING CHARACTERISTICS AT RATED POWER			DIRECT START		MAX WATER TEMPERATURE °C	CABLE TYPE (SINGLE POLE)		
	THREE-PHASE kW	HP			rpm	η %	cos ϕ	Ts/Tn	Is/In		D.O.L. 1x...(n.4)	Y / D 1x...(n.7)	L m
L8W300T405	30	40	380	64,6	2870	81,9	0,86	1,37	4,68	30	10	6	5,5
			400	62,8	2885	82,5	0,835	1,53	5,06				
			415	62,9	2895	82,1	0,81	1,65	5,24				
L8W370T405	37	50	380	79,6	2900	83,3	0,85	1,25	5,15	30	10	6	5,5
			400	78,9	2910	83,2	0,81	1,39	5,46				
			415	79,9	2920	82,9	0,78	1,50	5,59				
L8W450T405	45	60	380	94,0	2895	83,2	0,87	1,24	4,88	30	16	6	5,5
			400	91,2	2910	83,9	0,85	1,38	5,30				
			415	90,6	2915	84,0	0,82	1,49	5,54				
L8W520T405	52	70	380	107	20905	84,9	0,87	1,43	5,73	30	16	6	5,5
			400	104,7	2920	85,3	0,84	1,59	6,16				
			415	105	2920	85,1	0,81	1,72	6,37				
L8W550T405	55	75	380	115	2910	85,3	0,86	1,54	5,91	30	16	10	5,5
			400	113,3	2925	85,5	0,82	1,71	6,29				
			415	115	2930	85,1	0,78	1,84	6,45				
L8W600T405	60	80	380	126	2905	85,4	0,85	1,95	5,98	30	25	10	5,5
			400	125	2915	85,6	0,81	2,17	6,35				
			415	121	2920	85,1	0,81	2,34	6,80				
L8W670T405	67	90	380	136,4	2920	86,3	0,87	1,66	6,56	30	25	10	5,5
			400	134	2930	86,4	0,84	1,85	7,02				
			415	134	2920	86,6	0,8	1,99	7,26				
L8W750T405	75	100	380	150	2910	86,1	0,89	1,39	5,85	30	25	16	5,5
			400	145	2920	86,7	0,86	1,54	6,36				
			415	142,6	2930	87,0	0,84	1,66	6,70				
L8W830T405	83	110	380	165,5	2905	85,8	0,89	1,44	5,73	30	35	16	5,5
			400	159	2915	86,5	0,87	1,60	6,27				
			415	156	2920	86,9	0,85	1,73	6,64				
L8W930T405	93	125	380	188	2905	84,7	0,89	1,46	5,72	30	35	16	5,5
			400	180	2915	85,9	0,87	1,63	6,28				
			415	177	2925	86,1	0,85	1,76	6,64				
L8W1100T405	110	150	380	217,5	2915	87,1	0,88	1,70	6,25	30	35	16	5,5
			400	210	2925	87,8	0,86	1,89	6,81				
			415	207,5	2935	87,9	0,84	2,04	7,16				

Ts/Tn = ratio between starting torque and nominal torque.

Is/In = ratio between starting current and nominal current.

l8w_c-2p50-en_a_te

G8W HT MOTOR SERIES THREE-PHASE OPERATING CHARACTERISTICS AT 50 Hz

MOTOR TYPE THREE-PHASE	RATED POWER		RATED VOLTAGE V	RATED CURRENT A	OPERATING CHARACTERISTICS AT RATED POWER			DIRECT START		MAX WATER TEMPERATURE °C	CABLE TYPE (SINGLE POLE)		
	kW	HP			rpm	η %	cosj	Ts/Tn	Is/In		D.O.L. 1x...(n.4)	Y / D 1x...(n.7)	L m
L8W300T405 HT	30	40	380	63,3	2885	80,7	0,89	1,15	4,71	45	10	6	5,5
			400	63,7	2895	80,7	0,843	1,28	4,93				
			415	66,6	2905	79,8	0,79	1,38	4,89				
L8W370T405 HT	37	50	380	77,8	2895	82,1	0,88	1,02	5,22	45	10	6	5,5
			400	79,6	2905	81,8	0,82	1,14	5,39				
			415	83,7	2915	80,7	0,76	1,23	5,30				
L8W450T405 HT	45	60	380	94,7	2885	80,0	0,9	1,01	4,79	45	16	6	5,5
			400	93,1	2900	80,5	0,87	1,13	5,13				
			415	94,9	2905	80,1	0,82	1,22	5,22				
L8W520T405 HT	52	70	380	107,4	2900	82,1	0,9	1,17	5,64	45	16	6	5,5
			400	106,3	2910	82,3	0,86	1,30	6,00				
			415	108,5	2920	82,0	0,81	1,40	6,10				
L8W550T405 HT	55	75	380	114,2	2905	83,0	0,88	1,25	5,87	45	16	10	5,5
			400	114,8	2915	82,9	0,83	1,39	6,15				
			415	119,3	2925	82,4	0,78	1,50	6,14				
L8W600T405 HT	60	80	380	125,4	2915	83,6	0,87	1,61	5,95	45	25	10	5,5
			400	126,8	2925	83,5	0,82	1,79	6,19				
			415	132,4	2930	82,7	0,76	1,93	6,15				
L8W670T405 HT	67	90	380	137,4	2915	84,6	0,88	1,36	6,45	45	25	10	5,5
			400	136,1	2925	84,8	0,84	1,51	6,85				
			415	139,5	2930	84,4	0,79	1,63	6,93				
L8W750T405 HT	75	100	380	149	2910	84,8	0,91	1,13	5,84	45	25	16	5,5
			400	145	2920	85,0	0,88	1,26	6,28				
			415	145,8	2925	85,0	0,84	1,36	6,49				
L8W830T405 HT	83	110	380	164,9	2905	84,7	0,9	1,18	5,69	45	-	25	5,5
			400	160,7	2915	85,1	0,88	1,31	6,15				
			415	160,4	2920	85,2	0,85	1,41	6,39				
L8W930T405 HT	93	125	380	186,9	2900	84,4	0,9	1,20	5,69	45	-	25	5,5
			400	181,3	2915	85,1	0,87	1,34	6,18				
			415	181,5	2920	84,9	0,84	1,45	6,41				
L8W1100T405 HT	110	150	380	220,5	2905	84,7	0,9	1,38	6,11	45	-	25	5,5
			400	212,5	2915	85,4	0,88	1,54	6,67				
			415	209,8	2925	85,7	0,85	1,66	7,01				

Ts/Tn = ratio between starting torque and nominal torque.

Is/In = ratio between starting current and nominal current.

l8w_c ht-2p50-en_a_te

10" Submersible motors G10W Series

Submersible water filled rewindable motors.



SPECIFICATIONS

- **Stainless steel** outer sleeve.
- Shaft extension and coupling dimensions to **NEMA** standards.
- **Class insulation:**
70 for standard version.
85 for HT version.
- **Protection class:**
IP68.
- Internal fluid suitable for contact with foodstuffs.
- Strong and durable compensating bellows.
- Axial load supported by angular bearings.
- Mechanical seal protected by sand guard.
- **Maximum immersion depth:**
350 m.
- Suitable for both vertical / horizontal installations from the pump to the motor.
- **Maximum number of starts per hour at regular intervals:**
8.
- **Maximum water temperature:**
30°C for standard version
45°C for HT version
Max. temperature applies to motors working in a installation capable of delivering a flow of water around the motor jacket of at least 0,5 m/s.
- **Axial thrust:**
65000 N from 83 to 150 kW.
- **Version:**
Three-phase:
from 83 to 150 kW
380-415 V ± 6% 50 Hz

- **Rewindable stator**
- **Mechanical seal**
- **Kingsbury type thrust bearing**
- **Approvals:**
 - ACS
 - D.M. 174/2004

OPTIONAL FEATURES

- Silicon Carbide mechanical seal.
- **G10WN** version made of stainless steel.
- **G10WR** version made of Duplex stainless steel.
- **HT** version for high temperature.
- Different voltages and frequencies.
- Motors with double cable outlet for star/delta start can be supplied upon request.
- Supply cable available with junction or not.

For application limits, refer to technical appendix chapter.

ACCESSORIES

- Temperature sensor **PT 100 / PTC.**
- Control panels.
- Drop cables
- Coupling flange.
- Cooling sleeve.
- Screws to fix the pump.

**G10W - G10WN - G10WR MOTOR SERIES
 MOTOR CROSS SECTION**

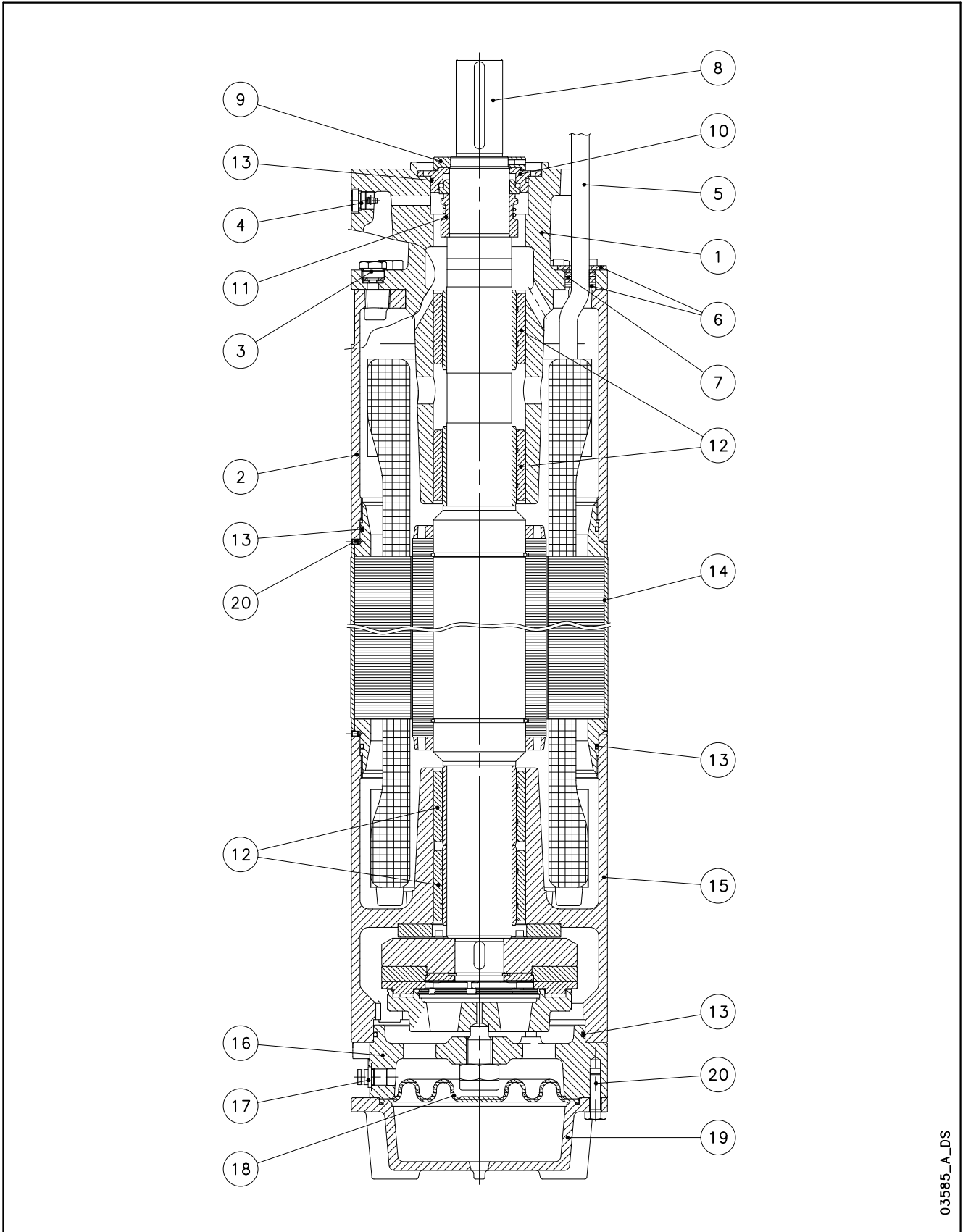

03585_A_DS

G10W TABLE OF MATERIALS

REF. N°	PART	MATERIAL	DESIGNATION	
			EUROPE	USA
1	Upper bracket	Cast iron	EN 1561-EN-GJL-200 (EN-JL1030)	Class 25 B
2	Spacer	Cast iron	EN 1561-EN-GJL-200 (EN-JL1030)	Class 25 B
3	Filling plug (+OR)	Stainless steel (+NBR)	EN 10088-1-X5CrNiMo17-12-2 (1.4401)	AISI 316
4	Vent valve	Stainless steel	EN 10088-1-X5CrNiMo17-12-2 (1.4401)	AISI 316
5	Cable	EPR		
6	Cable gland plate	Stainless steel	EN 10088-1-X5CrNi18-10 (1.4301)	AISI 304
7	Cable gland	EPDM		
8	Shaft end	Duplex stainless steel	EN 10088-1-X2CrNiMoN22-5-3 (1.4462)	A276/A790-S31803
9	Removable sand guard	Stainless steel	EN 10088-1-X2CrNiMo17-12-2 (1.4404)	AISI 316L
10	Mechanical seal cover	Stainless steel	EN 10088-1-X2CrNiMo17-12-2 (1.4404)	AISI 316L
11	Mechanical seal	Carbon-graphite / Ceramic		
12	Bush bearings	Carbon-graphite		
13	Elastomers	NBR		
14	Motor sleeve	Stainless steel	EN 10088-1-X2CrNi19-11 (1.4306)	AISI304L
15	Lower bracket	Cast iron	EN 1561-EN-GJL-200 (EN-JL1030)	Class 25 B
16	Thrust bearing bracket	Cast iron	EN 1561-EN-GJL-200 (EN-JL1030)	Class 25 B
17	Filling valve	Stainless steel	EN 10088-1-X5CrNiMo17-12-2 (1.4401)	AISI 316
18	Diaphragm	EPDM		
19	Lower cover	Cast iron	EN 1561-EN-GJL-200 (EN-JL1030)	Class 25 B
20	Bolts and screws	Stainless steel	EN 10088-1-X5CrNi18-10 (1.4301)	AISI 304
-	Cooling liquid	Water + antifreeze		

L8-L10w-2p50-en_b_tm

G10WN TABLE OF MATERIALS

REF. N°	PART	MATERIAL	DESIGNATION	
			EUROPE	USA
1	Upper bracket	Stainless steel	EN 10213-4 - GX5CrNiMo19-11-2 (1.4408)	ASTM CF-8M (AISI 316 cast)
2	Spacer	Stainless steel	EN 10213-4 - GX5CrNiMo19-11-2 (1.4408)	ASTM CF-8M (AISI 316 cast)
3	Filling plug (+OR)	Stainless steel	EN 10088-1-X5CrNiMo17-12-2 (1.4401)	AISI 316
4	Vent valve	Stainless steel	EN 10088-1-X5CrNiMo17-12-2 (1.4401)	AISI 316
5	Cable	EPR		
6	Cable gland plate	Stainless steel	EN 10088-1-X5CrNiMo17-12-2 (1.4401)	AISI 316
7	Cable gland	EPDM		
8	Shaft end	Duplex stainless steel	EN 10088-1-X2CrNiMoN22-5-3 (1.4462)	A276/A790-S31803
9	Removable sand guard	Stainless steel	EN 10088-1-X2CrNiMo17-12-2 (1.4404)	AISI 316L
10	Mechanical seal cover	Stainless steel	EN 10088-1-X2CrNiMo17-12-2 (1.4404)	AISI 316L
11	Mechanical seal	Carbon-graphite / Aluminium oxide		
12	Bush bearings	Carbon-graphite		
13	Elastomers	NBR		
14	Motor sleeve	Stainless steel	EN 10088-1-X2CrNiMo17-12-2 (1.4404)	AISI 316L
15	Lower bracket	Stainless steel	EN 10213-4 - GX5CrNiMo19-11-2 (1.4408)	ASTM CF-8M (AISI 316 cast)
16	Thrust bearing bracket	Stainless steel	EN 10213-4 - GX5CrNiMo19-11-2 (1.4408)	ASTM CF-8M (AISI 316 cast)
17	Filling valve	Stainless steel	EN 10088-1-X5CrNiMo17-12-2 (1.4401)	AISI 316
18	Diaphragm	EPDM		
19	Lower cover	Stainless steel	EN 10213-4 - GX5CrNiMo19-11-2 (1.4408)	ASTM CF-8M (AISI 316 cast)
20	Bolts and screws	Stainless steel	EN 10088-1-X5CrNiMo17-12-2 (1.4401)	AISI 316
-	Cooling liquid	Water + antifreeze		

L8-L10wn-2p50-en_b_tm

G10WR TABLE OF MATERIALS

REF. N°	PART	MATERIAL	DESIGNATION	
			EUROPE	USA
1	Upper bracket	Duplex stainless steel	EN 10213-4-GX2CrNiMoCuN25-6-3-3 (1.4517)	
2	Spacer	Duplex stainless steel	EN 10213-4-GX2CrNiMoCuN25-6-3-3 (1.4517)	
3	Filling plug (+OR)	Duplex steel (+NBR)	EN 10088-1-X2CrNiMoN22-5-3 (1.4462)	A276/A790-S31803
4	Vent valve	Duplex stainless steel	EN 10088-1-X2CrNiMoN22-5-3 (1.4462)	A276/A790-S31803
5	Cable	EPR		
6	Cable gland plate	Stainless steel	EN 10088-1X1NiCrMoCu25-20-5 (1.4539)	AISI 904L
7	Cable gland	EPDM		
8	Shaft end	Duplex stainless steel	EN 10088-1-X2CrNiMoN22-5-3 (1.4462)	A276/A790-S31803
9	Removable sand guard	Duplex stainless steel	EN 10088-1-X2CrNiMoN22-5-3 (1.4462)	A276/A790-S31803
10	Mechanical seal cover	Duplex stainless steel	EN 10088-1-X2CrNiMoN22-5-3 (1.4462)	A276/A790-S31803
11	Mechanical seal	Carbon-graphite / Aluminium oxide		
12	Bush bearings	Carbon-graphite		
13	Elastomers	NBR		
14	Motor sleeve	Stainless steel	EN 10088-1X1NiCrMoCu25-20-5 (1.4539)	AISI 904L
15	Lower bracket	Duplex stainless steel	EN 10213-4-GX2CrNiMoCuN25-6-3-3 (1.4517)	
16	Thrust bearing bracket	Duplex stainless steel	EN 10213-4-GX2CrNiMoCuN25-6-3-3 (1.4517)	
17	Filling valve	Duplex stainless steel	EN 10088-1-X2CrNiMoN22-5-3 (1.4462)	A276/A790-S31803
18	Diaphragm	EPDM		
19	Lower cover	Duplex stainless steel	EN 10213-4-GX2CrNiMoCuN25-6-3-3 (1.4517)	
20	Bolts and screws	Duplex stainless steel	EN 10088-1-X2CrNiMoN22-5-3 (1.4462)	A276/A790-S31803
-	Cooling liquid	Water + antifreeze		

L8-L10wr-2p50-en_b_tm

G10W MOTOR SERIES IDENTIFICATION CODE

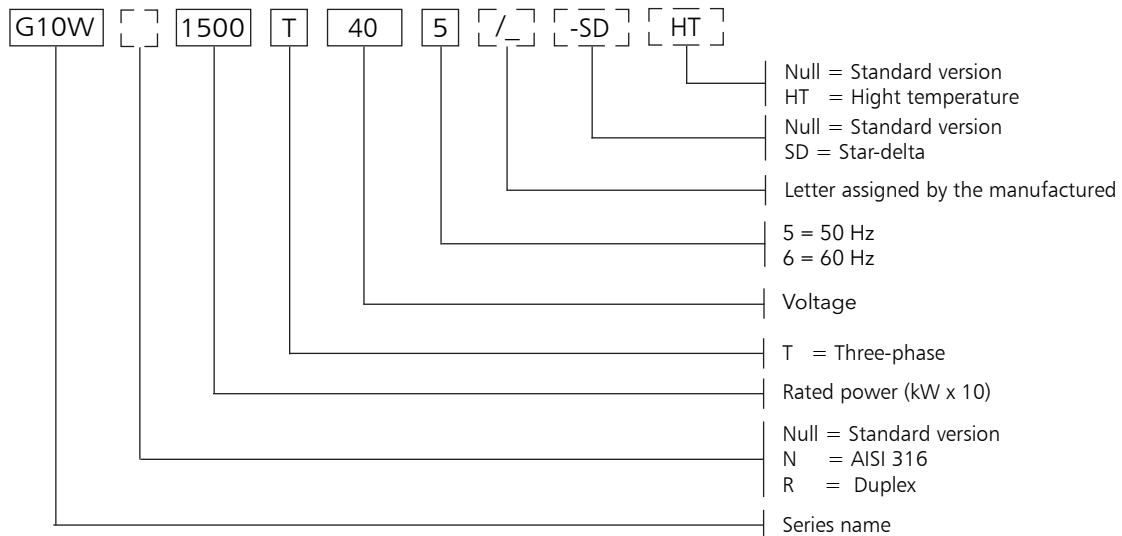

EXAMPLE: G10W1500T405/C HT

G10W = Motor series G10W
1500 = Rated power 150 kW
T = Three-phase
40 = Voltage 380-415 V
5 = Frequency 50 Hz.
HT = high temperature.

RATING PLATE

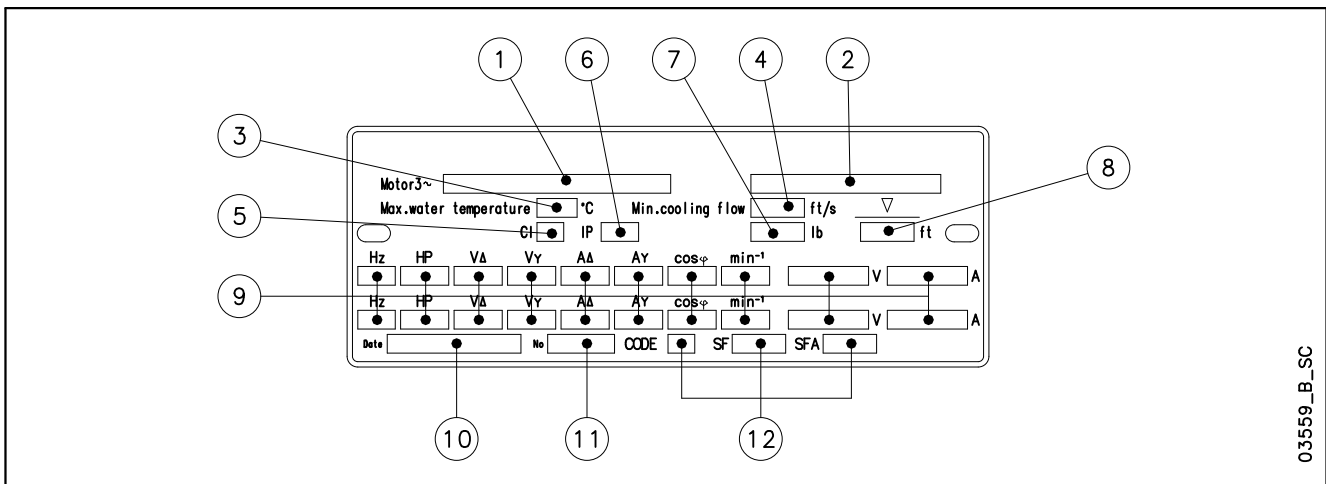

LEGEND

- 1 - Motor type
- 2 - Code
- 3 - Maximum water temperature
- 4 - Minimum water velocity
- 5 - Insulation class
- 6 - Protection class
- 7 - Weight
- 8 - Maximum immersion depth
- 9 - Operating characteristics
- 10 - Production date
- 11 - Serial number
- 12 - Characteristics at service factor

03559_B_SC

**G10W MOTOR SERIES
DIMENSIONS AND WEIGHTS AT 50 Hz**

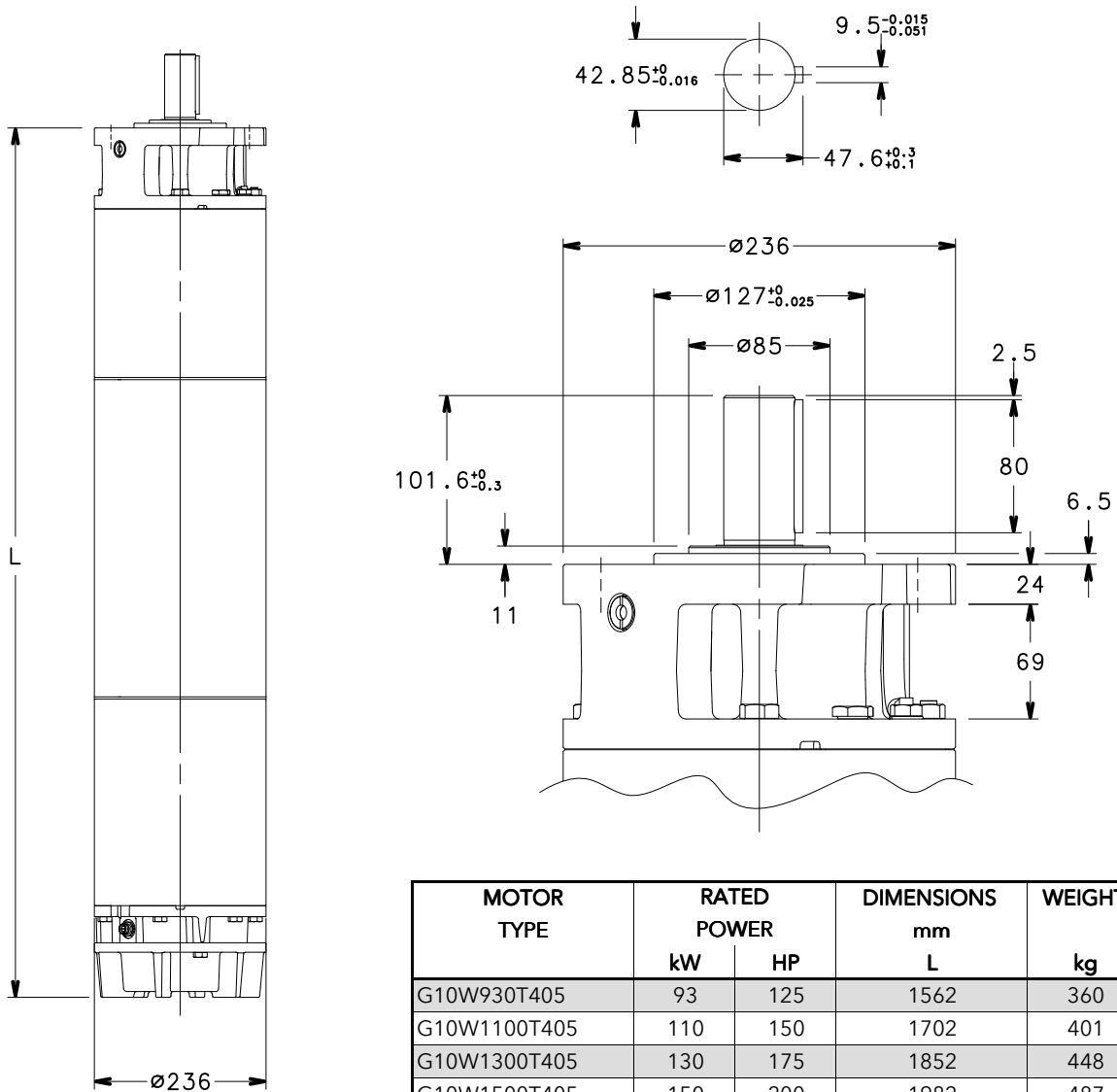

G10w-2p50-en_a_td

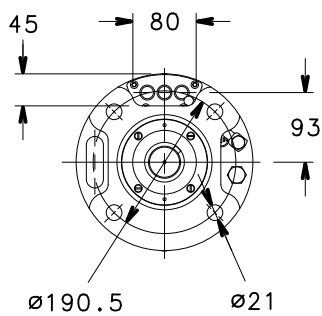

MOTOR TYPE	RATED POWER		DIMENSIONS mm L	WEIGHT kg
	kW	HP		
G10W830T405 HT	83	110	1562	360
G10W930T405 HT	93	125	1702	401
G10W1100T405 HT	110	150	1852	448
G10W1300T405 HT	130	175	1982	487

G10w-ht-2p50-en_a_td

03554_C_DD

G10W MOTOR SERIES THREE-PHASE OPERATING CHARACTERISTICS AT 50 Hz

MOTOR TYPE	RATED POWER		RATED VOLTAGE	RATED CURRENT	OPERATING CHARACTERISTICS AT RATED POWER			DIRECT START		MAX WATER TEMPERATURE °C	CABLE TYPE (SINGLE POLE)		
	THREE-PHASE kW	HP			V	A	rpm	η %	cosj		Ts/Tn	Is/In	D.O.L. 1x...(n.4)
L10W930T405	93	125	380	191	2915	85,5	0,87	1,18	5,38	30	35	16	5,5
			400	186	2925	85,8	0,84	1,31	5,81				
			415	186	2930	85,7	0,81	1,42	6,04				
L10W1100T405	110	150	380	221	2915	86,6	0,87	0,98	5,52	30	50	25	5,5
			400	214	2925	86,9	0,85	1,09	6,00				
			415	212	2935	87,1	0,83	1,17	6,30				
L10W1300T405	130	175	380	262	2920	87,1	0,87	1,01	5,83	30	70	25	5,5
			400	256	2930	87,4	0,84	1,13	6,28				
			415	254	2935	87,4	0,81	1,21	6,55				
L10W1500T405	150	200	380	298	2920	87,8	0,87	1,10	5,82	30	70	35	5,5
			400	290	2930	88,0	0,85	1,22	6,30				
			415	287	2935	88,2	0,83	1,32	6,60				

Ts/Tn = ratio between starting torque and nominal torque.

l10w-2p50-en_e_te

Is/In = ratio between starting current and nominal current.

G10W HT MOTOR SERIES THREE-PHASE OPERATING CHARACTERISTICS AT 50 Hz

MOTOR TYPE	RATED POWER		RATED VOLTAGE	RATED CURRENT	OPERATING CHARACTERISTICS AT RATED POWER			DIRECT START		MAX WATER TEMPERATURE °C	CABLE TYPE (SINGLE POLE)		
	THREE-PHASE kW	HP			V	A	rpm	η %	cosj		Ts/Tn	Is/In	D.O.L. 1x...(n.4)
L10W830T405 HT	83	110	380	172	2925	85,7	0,86	1,33	5,97	45	50	25	5,5
			400	169	2935	85,9	0,83	1,48	6,40				
			415	170	2940	85,6	0,79	1,59	6,61				
L10W930T405 HT	93	125	380	189	2930	86,9	0,86	1,16	6,46	45	70	25	5,5
			400	185	2940	86,9	0,83	1,29	6,93				
			415	185	2945	87,0	0,81	1,39	7,21				
L10W1100T405 HT	110	150	380	225	2935	87,4	0,85	1,20	6,78	45	70	35	5,5
			400	223	2945	87,4	0,82	1,34	7,22				
			415	224	2945	87,2	0,78	1,44	7,44				
L10W1300T405 HT	130	175	380	261	2930	88,1	0,87	1,28	6,64	45	-	35	5,5
			400	256	2940	88,2	0,83	1,42	7,12				
			415	256	2945	88,2	0,80	1,53	7,40				

Ts/Tn = ratio between starting torque and nominal torque.

l10w-ht-2p50-en_e_c_te

Is/In = ratio between starting current and nominal current.

12" Submersible motors G12W Series

Submersible water filled rewindable motors.



SPECIFICATIONS

- **Stainless steel** outer sleeve.
- Shaft extension and coupling dimensions to NEMA standards.
- **Class insulation:**
70 for standard version.
85 for HT version.
- **Protection class:**
IP68.
- Internal fluid suitable for contact with foodstuffs.
- Strong and durable compensating bellows.
- Axial load supported by angular bearings.
- Mechanical seal protected by sand guard.
- **Maximum immersion depth:**
350 m.
- Suitable for both vertical / horizontal installations
- **Maximum number of starts per hour at regular intervals:**
4.
- **Maximum water temperature:**
30°C for standard version
45°C for HT version
Max. temperature applies to motors working in a installation capable of delivering a flow of water around the motor jacket of at least 0,5 m/s.
- **Axial thrust:**
65000 N from 185 to 300 kW.
- **Version:**
Three-phase:
from 150 to 300 kW
380-415 V \pm 6% 50 Hz
Star-delta starting is standard for all model ,except for G12W1850T405.

- **Rewindable stator**
- **Mechanical seal**
- **Kingsbury type thrust bearing**
- **Approvals:**
- ACS
- D.M. 174/2004

OPTIONAL FEATURES

- Silicon Carbide mechanical seal.
- **G12WN version** made of stainless steel.
- **G12WR version** made of Duplex stainless steel.
- **HT version** for high temperature.
- Different voltages and frequencies
- Motors with double cable outlet for star/delta start can be supplied upon request (only for G12W1850T405).
- Supply cable available with W or not.

For application limits, refer to technical appendix chapter.

ACCESSORIES

- Temperature sensor **PT 100 / PTC.**
- Control panels.
- Drop cables
- Coupling flange.
- Cooling sleeve.
- Screws to fix the pump.

**G12W - G12WN - G12WR MOTOR SERIES
 MOTOR CROSS SECTION**

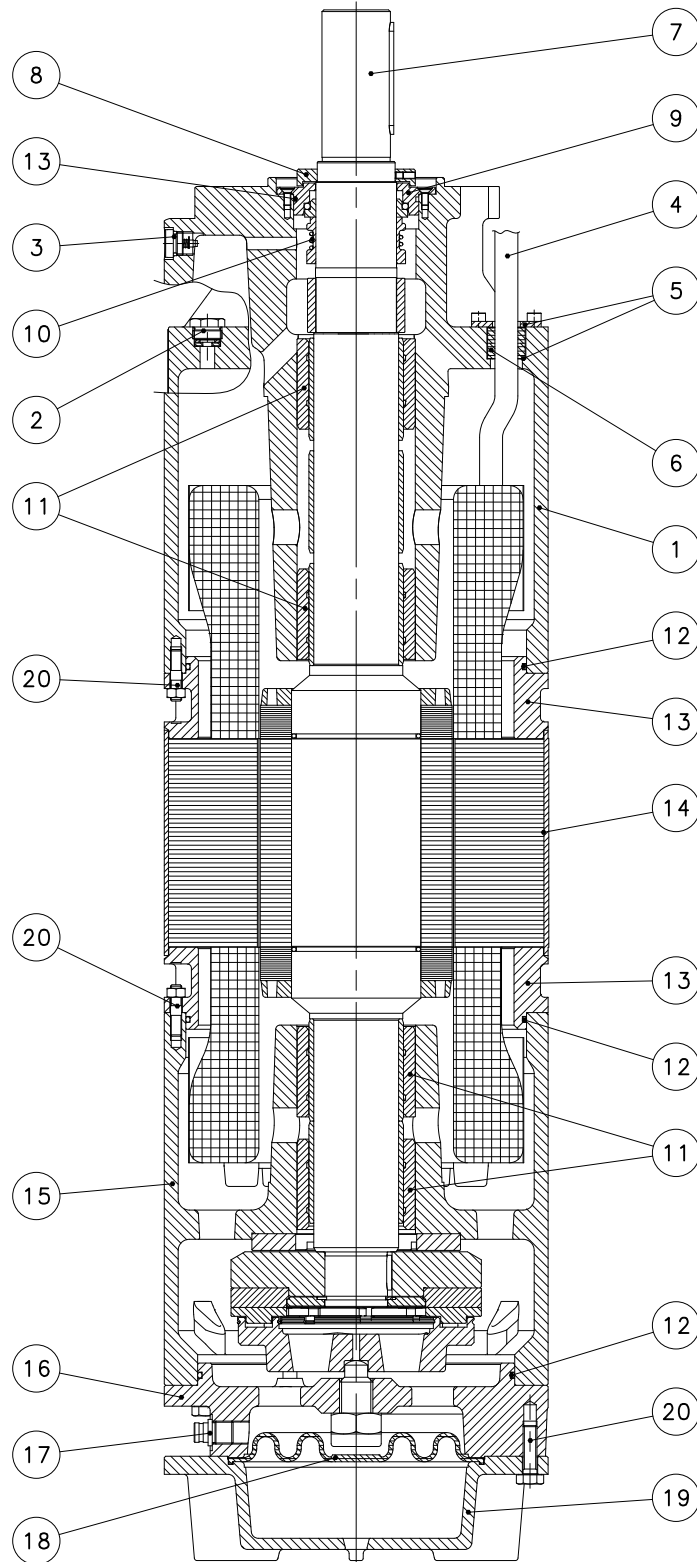

03590_A_DS

G12W TABLE OF MATERIALS

REF. N°	PART	MATERIAL	DESIGNATION	
			EUROPE	USA
1	Upper bracket	Cast iron	EN 1561-EN-GJL-200 (EN-JL1030)	Class 25 B
2	Filling plug (+OR)	Stainless steel + NBR	EN 10088-1-X5CrNiMo17-12-2 (1.4401)	AISI 316
3	Vent valve	Stainless steel	EN 10088-1-X5CrNiMo17-12-2 (1.4401)	AISI 316
4	Cable	EPR		
5	Cable gland plate	Stainless steel	EN 10088-1-X5CrNiMo17-12-2 (1.4401)	AISI 316
6	Cable gland	EPDM		
7	Shaft end	Duplex stainless steel	EN 10088-1-X2CrNiMoN22-5-3 (1.4462)	A276/A790-S31803
8	Removable sand guard	Stainless steel	EN 10088-1-X2CrNiMo17-12-2 (1.4404)	AISI 316L
9	Mechanical seal cover	Stainless steel	EN 10088-1-X2CrNiMo17-12-2 (1.4404)	AISI 316L
10	Mechanical seal	Carbon-graphite / Ceramic		
11	Bush bearings	Carbon-graphite		
12	Elastomers	NBR		
13	Stator flanges	Carbon steel	EN 10297-1 - E355 (Fe 510)	
14	Motor sleeve	Stainless steel	EN 10088-1-X2CrNi19-11 (1.4306)	AISI304L
15	Lower bracket	Cast iron	EN 1561-EN-GJL-200 (EN-JL1030)	Class 25 B
16	Thrust bearing bracket	Cast iron	EN 1561-EN-GJL-200 (EN-JL1030)	Class 25 B
17	Filling valve	Stainless steel	EN 10088-1-X5CrNiMo17-12-2 (1.4401)	AISI 316
18	Diaphragm	EPDM		
19	Lower cover	Cast iron	EN 1561-EN-GJL-200 (EN-JL1030)	Class 25 B
20	Bolts and screws	Stainless steel	EN 10088-1-X5CrNi18-10 (1.4301)	AISI304
-	Cooling liquid	Water + antifreeze		

L12w-2p50-en_b_tm

G12WN TABLE OF MATERIALS

REF. N°	PART	MATERIAL	DESIGNATION	
			EUROPE	USA
1	Upper bracket	Stainless steel	EN 10213-4 - GX5CrNiMo19-11-2 (1.4408)	ASTM CF-8M (AISI 316 cast)
2	Filling plug (+OR)	Stainless steel + NBR	EN 10088-1-X5CrNiMo17-12-2 (1.4401)	AISI 316
3	Vent valve	Stainless steel	EN 10088-1-X5CrNiMo17-12-2 (1.4401)	AISI 316
4	Cable	EPR		
5	Cable gland plate	Stainless steel	EN 10088-1-X5CrNiMo17-12-2 (1.4401)	AISI 316
6	Cable gland	EPDM		
7	Shaft end	Duplex stainless steel	EN 10088-1-X2CrNiMoN22-5-3 (1.4462)	A276/A790-S31803
8	Removable sand guard	Stainless steel	EN 10088-1-X2CrNiMo17-12-2 (1.4404)	AISI 316L
9	Mechanical seal cover	Stainless steel	EN 10088-1-X2CrNiMo17-12-2 (1.4404)	AISI 316L
10	Mechanical seal	Carbon-graphite / Ceramic		
11	Bush bearings	Carbon-graphite		
12	Elastomers	NBR		
13	Stator flanges	Stainless steel	EN 10088-1-X5CrNiMo17-12-2 (1.4401)	AISI 316
14	Motor sleeve	Stainless steel	EN 10088-1-X2CrNiMo17-12-2 (1.4404)	AISI 316L
15	Lower bracket	Stainless steel	EN 10213-4 - GX5CrNiMo19-11-2 (1.4408)	ASTM CF-8M (AISI 316 cast)
16	Thrust bearing bracket	Stainless steel	EN 10213-4 - GX5CrNiMo19-11-2 (1.4408)	ASTM CF-8M (AISI 316 cast)
17	Filling valve	Stainless steel	EN 10088-1-X5CrNiMo17-12-2 (1.4401)	AISI 316
18	Diaphragm	EPDM		
19	Lower cover	Stainless steel	EN 10213-4 - GX5CrNiMo19-11-2 (1.4408)	ASTM CF-8M (AISI 316 cast)
20	Bolts and screws	Stainless steel	EN 10088-1-X5CrNiMo17-12-2 (1.4401)	AISI 316
	Cooling liquid	Water + antifreeze		

L12wn-2p50-en_b_tm

G12WR TABLE OF MATERIALS

REF. N°	PART	MATERIAL	DESIGNATION	
			EUROPE	USA
1	Upper bracket	Duplex stainless steel	EN 10213-4-GX2CrNiMoCuN25-6-3-3 (1.4517)	
2	Filling plug (+OR)	Duplex stainless steel +NBR	EN 10088-1-X2CrNiMoN22-5-3 (1.4462)	A276/A790-S31803
3	Vent valve	Duplex stainless steel	EN 10088-1-X2CrNiMoN22-5-3 (1.4462)	A276/A790-S31803
4	Cable	EPR		
5	Cable gland plate	Stainless steel	EN 10088-1X1NiCrMoCu25-20-5 (1.4539)	AISI 904L
6	Cable gland	EPDM		
7	Shaft end	Duplex stainless steel	EN 10088-1-X2CrNiMoN22-5-3 (1.4462)	A276/A790-S31803
8	Removable sand guard	Duplex stainless steel	EN 10088-1-X2CrNiMoN22-5-3 (1.4462)	A276/A790-S31803
9	Mechanical seal cover	Duplex stainless steel	EN 10088-1-X2CrNiMoN22-5-3 (1.4462)	A276/A790-S31803
10	Mechanical seal	Carbon-graphite / Ceramic		
11	Bush bearings	Carbon-graphite		
12	Elastomers	NBR		
13	Stator flanges	Duplex stainless steel	EN 10213-4-GX2CrNiMoCuN25-6-3-3 (1.4517)	
14	Motor sleeve	Stainless steel	EN 10088-1X1NiCrMoCu25-20-5 (1.4539)	AISI 904L
15	Lower bracket	Duplex stainless steel	EN 10213-4-GX2CrNiMoCuN25-6-3-3 (1.4517)	
16	Thrust bearing bracket	Duplex stainless steel	EN 10213-4-GX2CrNiMoCuN25-6-3-3 (1.4517)	
17	Filling valve	Duplex stainless steel	EN 10088-1-X2CrNiMoN22-5-3 (1.4462)	A276/A790-S31803
18	Diaphragm	EPDM		
19	Lower cover	Duplex stainless steel	EN 10213-4-GX2CrNiMoCuN25-6-3-3 (1.4517)	
20	Bolts and screws	Duplex stainless steel	EN 10088-1-X2CrNiMoN22-5-3 (1.4462)	A276/A790-S31803
	Cooling liquid	Water + antifreeze		

L12wr-2p50-en_b_tm

G12W MOTOR SERIES IDENTIFICATION CODE

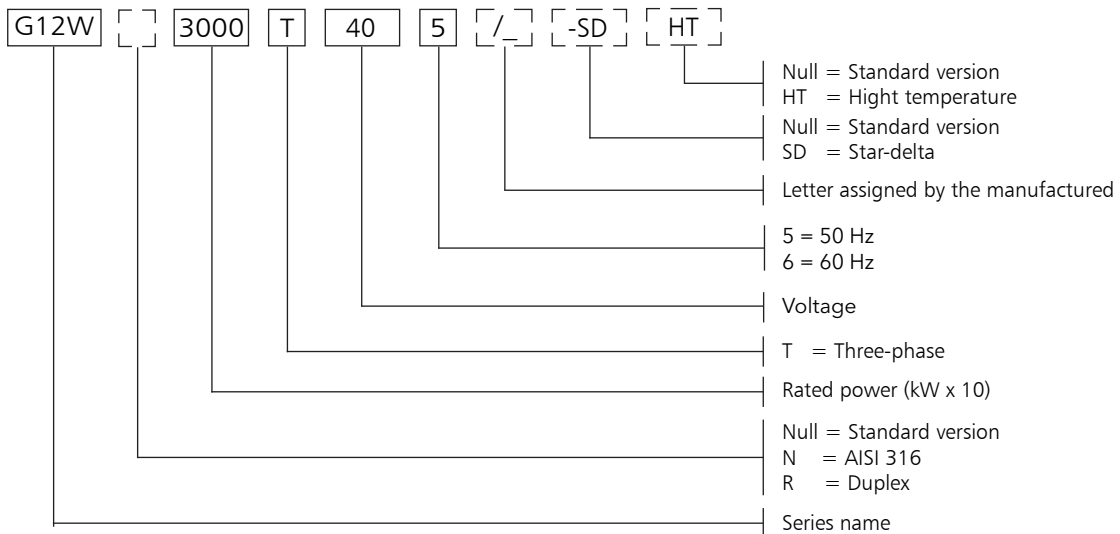

EXAMPLE: G12W1850T405/A HT

G12W = Motor series G12W
1850 = Rated power 185 kW
T = Three-phase
40 = Voltage 380-415 V
5 = Frequency 50 Hz.
HT = high temperature.

RATING PLATE

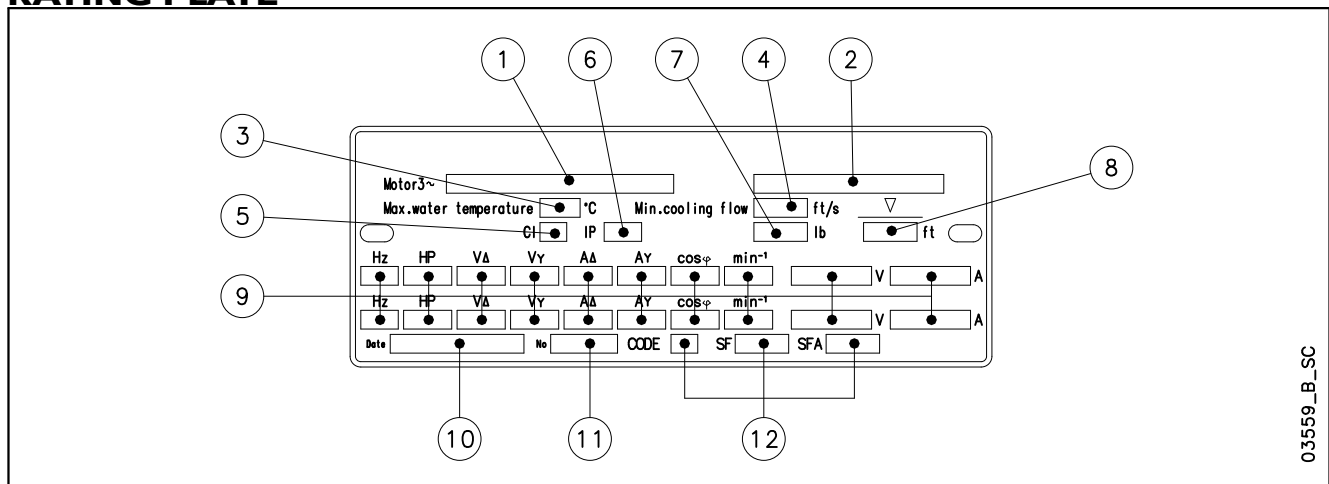

LEGEND

- 1 - Motor type
- 2 - Code
- 3 - Maximum water temperature
- 4 - Minimum water velocity
- 5 - Insulation class
- 6 - Protection class
- 7 - Weight
- 8 - Maximum immersion depth
- 9 - Operating characteristics
- 10 - Production date
- 11 - Serial number
- 12 - Characteristics at service factor

**G12W MOTOR SERIES
DIMENSIONS AND WEIGHTS AT 50 Hz**

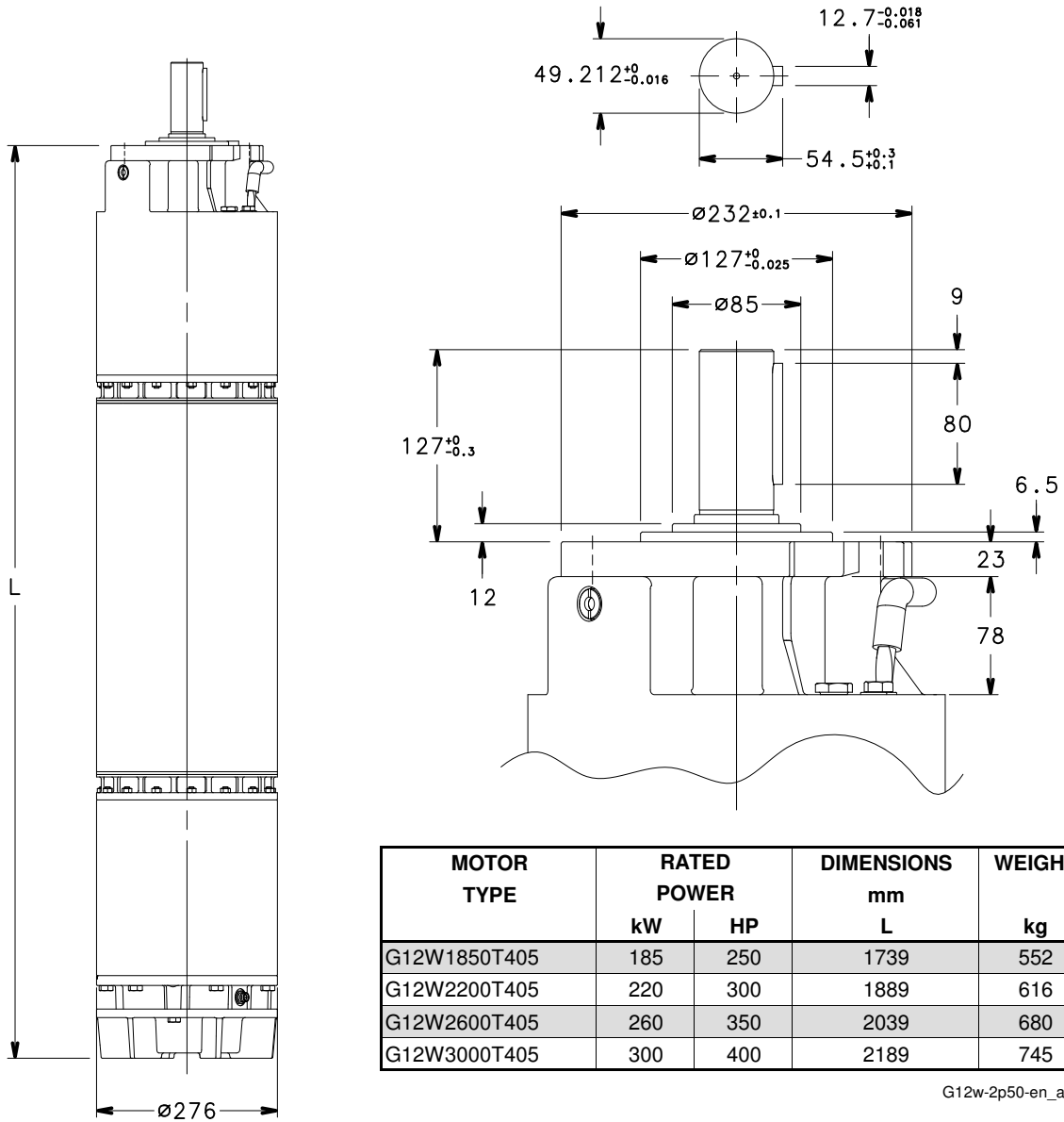

MOTOR TYPE	RATED POWER		DIMENSIONS mm L	WEIGHT kg
	kW	HP		
G12W1850T405	185	250	1739	552
G12W2200T405	220	300	1889	616
G12W2600T405	260	350	2039	680
G12W3000T405	300	400	2189	745

G12w-2p50-en_a_td

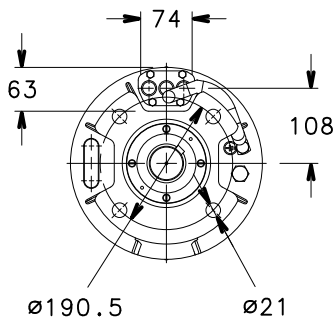

MOTOR TYPE	RATED POWER		DIMENSIONS mm L	WEIGHT kg
	kW	HP		
G12W1500T405-SD HT	150	200	1739	552
G12W1850T405-SD HT	185	250	1889	616
G12W2200T405-SD HT	220	300	2039	680

G12w-ht-2p50-en_a_td

03553_C_DD

G12W MOTOR SERIES THREE-PHASE OPERATING CHARACTERISTICS AT 50 Hz

MOTOR TYPE	RATED POWER		RATED VOLTAGE	RATED CURRENT	OPERATING CHARACTERISTICS AT RATED POWER			DIRECT START		MAX WATER TEMPERATURE °C	CABLE TYPE (SINGLE POLE)		
	kW	HP			V	A	rpm	η %	cosj		Ts/Tn	Is/In	D.O.L. 1x...(n.4)
L12W1850T405	185	250	380	378	2905	86,1	0,86	0,72	3,65	30	95	50	5,5
			400	359	2915	86,9	0,86	0,80	4,04				
			415	349	2925	87,3	0,85	0,87	4,31				
L12W2200T405	220	300	380	438	2925	87,6	0,87	0,57	4,13	30	-	70	5,5
			400	420	2930	88,2	0,86	0,64	4,54				
			415	413	2940	88,4	0,84	0,69	4,79				
L12W2600T405	260	350	380	512	2915	88,0	0,88	0,66	4,17	30	-	70	5,5
			400	488	2925	88,6	0,87	0,73	4,60				
			415	475	2935	89,1	0,85	0,79	4,90				
L12W3000T405	300	400	380	621	2940	89,2	0,82	0,72	4,20	30	-	95	5,5
			400	624	2945	89,1	0,78	0,80	4,65				
			415	640	2950	88,9	0,73	0,86	5,01				

Ts/Tn = ratio between starting torque and nominal torque.

I12w-2p50-en_e_te

Is/In = ratio between starting current and nominal current.

G12W HT MOTOR SERIES THREE-PHASE OPERATING CHARACTERISTICS AT 50 Hz

MOTOR TYPE	RATED POWER		RATED VOLTAGE	RATED CURRENT	OPERATING CHARACTERISTICS AT RATED POWER			DIRECT START		MAX WATER TEMPERATURE °C	CABLE TYPE (SINGLE POLE)		
	kW	HP			V	A	rpm	η %	cosj		Ts/Tn	Is/In	D.O.L. 1x...(n.4)
L12W1500T405-SD HT	150	200	380	303	2925	87,1	0,86	0,90	4,54	45	-	50	5,5
			400	292	2935	87,4	0,85	1,00	4,97				
			415	287	2940	87,7	0,83	1,08	5,25				
L12W1850T405-SD HT	185	250	380	368	2940	88,3	0,87	0,68	4,92	45	-	70	5,5
			400	357	2945	88,7	0,84	0,76	5,34				
			415	354	2950	88,6	0,82	0,82	5,59				
L12W2200T405-SD HT	220	300	380	431	2930	88,7	0,88	0,78	4,95	45	-	95	5,5
			400	415	2940	89,1	0,86	0,87	5,41				
			415	407	2945	89,4	0,84	0,93	5,73				

Ts/Tn = ratio between starting torque and nominal torque.

I12w-ht-2p50-en_c_te

Is/In = ratio between starting current and nominal current.

ErP 2009/125/EC

MOTOR

With the "Energy using Products" (EuP 2005/32/EC) and "Energy related Products" (ErP 2009/125/EC) directives, the European Commission has established requirements for promoting the use of products with low power consumption.

Among the various products considered there are also some typologies of pumps with the characteristics defined by the specific **Regulation (EU) n. 547/2012** implementing the requirements of Directives EuP and ErP.

In the case of submersible engines, designed to operate immersed in the liquid (Article 1, paragraph 2 letter a), is required inform about the below data:

THREE-PHASE MOTOR 50 Hz, 2 POLI

MOTOR TYPE		RATED POWER		YEAR OF MANUFACTURE	MANUFACTURER	No. OF POLES	OPERATING CONDITIONS		
		kW	HP				Altitude above sea m	T amb. min / max °C	ATEX
G4OS03T235	G4OS03T405	0,37	0,5	From 04/2014	Xylem Service Italia srl Reg. No. 07520560967 Montecchio Maggiore Vicenza Italy	2	≤ 1000	0 / 35	No
G4OS05T235	G4OS05T405	0,55	0,75						
G4OS07T235	G4OS07T405	0,75	1						
G4OS11T235	G4OS11T405	1,1	1,5						
G4OS15T235	G4OS15T405	1,5	2						
G4OS22T235	G4OS22T405	2,2	3						
G4OS30T235	G4OS30T405	3	4						
G4OS40T235	G4OS40T405	4	5,5						
G4OS55T235	G4OS55T405	5,5	7,5						
G4OS75T235	G4OS75T405	7,5	10						

Note: Observe the regulations and codes locally in force regarding sorted waste disposal.

G4OS-ErP-en_a_te

MOTOR TYPE		RATED POWER		YEAR OF MANUFACTURE	MANUFACTURER	No. OF POLES	OPERATING CONDITIONS		
		kW	HP				Altitude above sea m	T amb. min / max °C	ATEX
G4C03T235	G4C03T405	0,37	0,5	Da 06/2011	Xylem Service Italia srl Reg. No. 7520560967 Montecchio Maggiore Vicenza Italia	2	≤ 1000	0 / 35	No
G4C05T235	G4C05T405	0,55	0,75						
G4C07T235	G4C07T405	0,75	1						
G4C11T235	G4C11T405	1,1	1,5						
G4C15T235	G4C15T405	1,5	2						
G4C22T235	G4C22T405	2,2	3						
G4C30T235	G4C30T405	3	4						
G4C40T235	G4C40T405	4	5,5						
G4C55T235	G4C55T405	5,5	7,5						
-	G4C75T405	7,5	10						
G6C40T235	G6C40T405	4	5,5	Da 06/2011	Xylem Service Italia srl Reg. No. 7520560967 Montecchio Maggiore Vicenza Italia	2	≤ 1000	0 / 35	No
G6C55T235	G6C55T405	5,5	7,5						
G6C75T235	G6C75T405	7,5	10						
G6C93T235	G6C93T405	9,3	12,5						
G6C110T235	G6C110T405	11	15						
G6C150T235	G6C150T405	15	20						
G6C185T235	G6C185T405	18,5	25						
G6C220T235	G6C220T405	22	30						
-	G6C300T405	30	40						
-	G6C370T405	37	50						

Note: Observe the regulations and codes locally in force regarding sorted waste disposal.

G4C-G6C-ErP-en_a_te

THREE-PHASE MOTOR 50 Hz, 2 POLI

MOTOR TYPE		RATED POWER		YEAR OF MANUFACTURE	MANUFACTURER	No. OF POLES	OPERATING CONDITIONS		
		kW	HP				Altitude above sea m	T amb. min / max °C	ATEX
G6W40T405	G6W40T405 HT	4	5,5	From 06/2011		2	≤ 1000	0 / 35 0 / 45 (HT)	No
G6W55T405	G6W55T405 HT	5,5	7,5						
G6W75T405	G6W75T405 HT	7,5	10						
G6W93T405	G6W93T405 HT	9,3	12,5						
G6W110T405	G6W110T405 HT	11	15						
G6W130T405	G6W130T405 HT	13	17,5						
G6W150T405	G6W150T405 HT	15	20						
G6W185T405	G6W185T405 HT	18,5	25						
G6W220T405	G6W220T405 HT	22	30						
G6W260T405	G6W260T405 HT	26	35						
G6W300T405	G6W300T405 HT	30	40	From 06/2011	Xylem Service Italia srl Reg. No. 7520560967 Montecchio Maggiore Vicenza Italia	2	≤ 1000	0 / 35 0 / 45 (HT)	No
G6W370T405	-	37	50						
G8W300T405	G8W300T405 HT	30	40						
G8W370T405	G8W370T405 HT	37	50						
G8W450T405	G8W450T405 HT	45	60						
G8W520T405	G8W520T405 HT	52	70						
G8W550T405	G8W550T405 HT	55	75						
G8W600T405	G8W600T405 HT	60	80						
G8W670T405	G8W670T405 HT	67	90						
G8W750T405	G8W750T405 HT	75	100						
G8W830T405	G8W830T405 HT	83	110	From 06/2011		2	≤ 1000	0 / 35 0 / 45 (HT)	No
G8W930T405	-	93	125						
L8W1100T405	L8W1100T405 HT	110	150						
-	G10W830T405 HT	83	110						
G10W930T405	G10W930T405 HT	93	125						
G10W1100T405	G10W1100T405 HT	110	150						
G10W1300T405	G10W1300T405 HT	130	175						
G10W1500T405	-	150	200						
-	G12W1500T405-SD HT	150	200						
G12W1850T405	G12W1850T405-SD HT	185	250						
G12W2200T405-SD	G12W2200T405-SD HT	220	300						
G12W2600T405-SD	-	260	350						
G12W3000T405-SD	-	300	400						

Note: Observe the regulations and codes locally in force regarding sorted waste disposal.

Gw-ErP-en_a_te

G4OS - G4C MOTOR SERIES MOTOR - CONTROL PANEL COMBINATION TABLE

MOTOR TYPE G4OS - 4" SINGLE-PHASE	RATED POWER		RATED CURRENT 220-240 V A	CAPACITOR μ F / 450 V	PANEL TYPE				
	kW	HP			QSM...	QPC...	QPCS...	QSC...	QSCS...
	0,37	0,5			3,2	16	...03	...03	...03
0,55	0,75	4,3	20	...05	...05	...05	...05	...05	
0,75	1	5,6	30	...07	...07	...07	...07	...07	
1,1	1,5	7,6	40	...11	...11	...11	...11	...11	
1,5	2	10,5	50	-	...15	...15	...15	...15	
2,2	3	14,4	70	-	...22	...22	...22	...22	
4	5,5	24,9	90	-	-	-	...40	...40	

MOTOR TYPE G4OS - 4" THREE-PHASE	RATED POWER		RATED CURRENT 380-415 V A	PANEL TYPE				
	kW	HP		QTD/...	Q3D/...	Q3I/...	Q3A/...	Q3SF/...
	0,37	0,5		1,2	...03-05	...03-05	-	-
0,55	0,75	1,7	...05-07	...05-07	-	-	-	
0,75	1	2,4	...05-07	...05-07	-	-	-	
1,1	1,5	3,1	...07-15	...07-15	-	-	-	
1,5	2	4,4	...15-22	...15-22	-	-	-	
2,2	3	6,1	...15-22	...15-22	-	-	-	
3	4	7,1	...22-40	...22-40	-	-	-	
4	5,5	9,8	...22-40	...22-40	-	-	-	
5,5	7,5	13,7	...40-75	...40-75	...40-75	...40-75	...75	
7,5	10	18,7	...75-92	...75-92	...75-92	...75-92	...150	

For different voltages, please contact our sales network.

G4OS-2p50-en_a_tc

MOTOR TYPE G4C - 4" SINGLE-PHASE	RATED POWER		RATED CURRENT 220-240 V A	CAPACITOR μ F / 450 V	PANEL TYPE					
	kW	HP			QSM...	QPC...	QPCS...	QMC...	QMCS...	QSC...
	0,37	0,5			3,4	16	...03	...03	...03	...03
0,55	0,75	4,8	20	...05	...05	...05	...05	...05	-	
0,75	1	6,5	30	...07	...07	...07	...07	...07	-	
1,1	1,5	8,3	40	...11	...11	...11	...11	...11	-	
1,5	2	10,7	50	-	...15	...15	...15	...15	-	
2,2	3	15,3	70	-	...22	...22	...22	...22	-	
4	5,5	27,4	90	-	-	-	-	-	...40	

MOTOR TYPE G4C - 4" THREE-PHASE	RATED POWER		RATED CURRENT 380-415 V A	PANEL TYPE				
	kW	HP		QTD/...	Q3D/...	Q3I/...	Q3A/...	Q3SF/...
	0,37	0,5		1,8	...05-07	...05-07	-	-
0,55	0,75	2	...05-07	...05-07	-	-	-	
0,75	1	2,6	...07-15	...07-15	-	-	-	
1,1	1,5	3,6	...07-15	...07-15	-	-	-	
1,5	2	4,6	...15-22	...15-22	-	-	-	
2,2	3	6,2	...15-22	...15-22	-	-	-	
3	4	8,8	...22-40	...22-40	-	-	-	
4	5,5	10,5	...40-75	...40-75	-	-	-	
5,5	7,5	14,5	...40-75	...40-75	...40-75	...40-75	...75	
7,5	10	18,1	...75-92	...75-92	...75-92	...75-92	...150	

For different voltages please contact our sales network

g4c-2p50-en_a_tc

G6C - G6W MOTOR SERIES MOTOR - CONTROL PANEL COMBINATION TABLE

MOTOR TYPE THREE-PHASE L6C - 6"	RATED POWER		RATED CURRENT 380-415 V A	PANEL TYPE					
	KW	HP		GQTD/...	GQ3D/...	GQ3I/...	GQ3A/...	GQ3Y/...	GQ3SF/...
	4	5,5	11,0	...40-75	...40-75	...40-75	...40-75	...40-75	...75
5,5	7,5	14,6	...40-75	...40-75	...40-75	...40-75	...40-75	...75	
7,5	10	18,3	...75-92	...75-92	...75-92	...75-92	...75-92	...150	
9,3	12,5	22,8	-	...92-110	...92-110	...92-110	...92-110	...150	
11	15	26,0	-	...110-150	...110-150	...110-150	...110-150	...150	
15	20	34,2	-	...150-185	...150-185	...150-185	...150-185	...220	
18,5	25	42,0	-	...185-220	...185-220	...185-220	...185-220	...220	
22	30	47,5	-	...185-220	...185-220	...185-220	...185-220	...300	
30	40	63,5	-	...300-370	...300-370	...300-370	...300-370	...370	
37	50	80,0	-	-	...370-450	...370-450	...370-450	...450	

For different voltages, please contact our sales network.

G6c-2p50-en_e_tc

MOTOR TYPE THREE-PHASE G6W - 6"	RATED POWER		RATED CURRENT 380-415 V A	PANEL TYPE					
	KW	HP		GQTD/...	GQ3D/...	GQ3I/...	GQ3A/...	GQ3Y/...	GQ3SF/...
	4	5,5	9,89	...40-75	...40-75	...40-75	...40-75	...40-75	...75
5,5	7,5	12,7	...40-75	...40-75	...40-75	...40-75	...40-75	...75	
7,5	10	17,0	...75-92	...75-92	...75-92	...75-92	...75-92	...150	
9,3	12,5	20,5	-	...92-110	...92-110	...92-110	...92-110	...150	
11	15	24,2	-	...110-150	...110-150	...110-150	...110-150	...150	
13	17,5	28,1	-	...110-150	...110-150	...110-150	...110-150	...150	
15	20	32,1	-	...150-185	...150-185	...150-185	...150-185	...220	
18,5	25	38,5	-	...185-220	...185-220	...185-220	...185-220	...220	
22	30	47,3	-	...220-300	...220-300	...220-300	...220-300	...300	
26	35	56,5	-	...220-300	...220-300	...220-300	...220-300	...300	
30	40	63,8	-	...300-370	...300-370	...300-370	...300-370	...370	
37	50	81,8	-	-	...370-450	...370-450	...370-450	...450	
MOTOR TYPE THREE-PHASE G6W HT - 6"	4	5,5	10,5	...40-75	...40-75	...40-75	...40-75	...40-75	...75
	5,5	7,5	13,4	...40-75	...40-75	...40-75	...40-75	...40-75	...75
	7,5	10	17,3	...75-92	...75-92	...75-92	...75-92	...75-92	...150
	9,3	12,5	20,8	-	...92-110	...92-110	...92-110	...92-110	...150
	11	15	23,9	-	...110-150	...110-150	...110-150	...110-150	...150
	13	17,5	28,4	-	...110-150	...110-150	...110-150	...110-150	...150
	15	20	32,5	-	...150-185	...150-185	...150-185	...150-185	...220
	18,5	25	41,6	-	...185-220	...185-220	...185-220	...185-220	...220
	22	30	49,7	-	...220-300	...220-300	...220-300	...220-300	...300
	26	35	55,8	-	...220-300	...220-300	...220-300	...220-300	...300
30	40	68,8	-	...300-370	...300-370	...300-370	...300-370	...370	

For different voltages, please contact our sales network.

G6w-2p50-en_c_tc

G8W - G10W - G12W MOTOR SERIES MOTOR - CONTROL PANEL COMBINATION TABLE

MOTOR TYPE	RATED POWER		RATED CURRENT 380-415 V A	PANEL TYPE					
	kW	HP		GQ3D/...	GQ3I/...	GQ3A/...	GQ3SF/...		
MOTOR TYPE THREE-PHASE G8W - 8"	30	40	64,5	...300-370	...300-370	...300-370	...370		
	37	50	80	-	...370-450	...370-450	...450		
	45	60	95,9	-	...450-550	...450-550	...550		
	52	70	110	-	...550-750	...550-750	...590		
	55	75	118	-	...550-750	...550-750	...590		
	60	80	127	-	...550-750	...550-750	...750		
	67	90	140	-	...750-900	...750-900	...900		
	75	100	155	-	...750-900	...750-900	...900		
	83	110	171	-	...750-900	...750-900	...900		
	93	125	189	-	...900-1100	...900-1100	...1100		
MOTOR TYPE THREE-PHASE G8W HT - 8"	30	40	63,7	...300-370	...300-370	...300-370	...370		
	37	50	77	-	...370-450	...370-450	...450		
	45	60	94,7	-	...450-550	...450-550	...550		
	52	70	111	-	...550-750	...550-750	...590		
	55	75	116	-	...550-750	...550-750	...590		
	60	80	125	-	...550-750	...550-750	...750		
	67	90	137	-	...750-900	...750-900	...900		
	75	100	153	-	...750-900	...750-900	...900		
83	110	168	-	...750-900	...750-900	...900			

For different voltages, please contact our sales network.

G8w-2p50-en_d_tc

MOTOR TYPE	RATED POWER		RATED CURRENT 380-415 V A	PANEL TYPE					
	kW	HP		GQ3I/...	GQ3A/...	GQ3SF/...			
MOTOR TYPE THREE-PHASE G10W-10"	93	125	191	...900-1100	...900-1100	...1100			
	110	150	221	...1100-1320	...1100-1320	...1100			
	130	175	262	...1320-1600	...1320-1600	(1)			
	150	200	298	...1600-2000	...1600-2000	(1)			
MOTOR TYPE THREE-PHASE G10W HT-10"	83	110	172	...750-900	...750-900	...900			
	93	125	189	...900-1100	...900-1100	...1100			
	110	150	225	...1100-1320	...1100-1320	...1100			
	130	175	261	...1320-1600	...1320-1600	(1)			

(1) On request.

G10w-2p50-en_d_tc

For different voltages, please contact our sales network.

MOTOR TYPE	RATED POWER		RATED CURRENT 380-415 V A	PANEL TYPE					
	kW	HP		GQ3I/...	GQ3A/...	GQ3SF/...			
MOTOR TYPE THREE-PHASE G12W-12"	185	250	378	...1600-2000	...1600-2000	(1)			
	220	300	438	...2000-2500	...2000-2500	(1)			
	260	350	512	...2500-3150	...2500-3150	(1)			
	300	400	621	(1)	(1)	(1)			
MOTOR TYPE THREE-PHASE G12W HT-12"	150	200	303	...1600-2000	...1600-2000	(1)			
	185	250	368	...1600-2000	...1600-2000	(1)			
	220	300	431	...2000-2500	...2000-2500	(1)			

(1) On request.

G12w-2p50-en_d_tc

For different voltages, please contact our sales network.

TECHNICAL APPENDIX

G4OS - G4C - G6C - G6W - G8W - G10W - G12W MOTOR SERIES

TABLE OF POWER REDUCTION COEFFICIENTS WITH INCREASED WATER TEMPERATURE

MOTOR TYPE	RATED POWER kW	TEMPERATURE							
		°C							
		25	30	35	40	45	50	55	60
G4OS	all models	1,00	1,00	1,00	0,90	0,80	0,70	0,60	-
G4C		1,00	1,00	1,00	0,95	0,90	0,85	0,80	-
G6C		1,00	1,00	1,00	0,95	0,80	0,75	0,70	0,60
G6W		1,00	1,00	0,75	-	-	-	-	-
G8W		1,00	1,00	0,75	-	-	-	-	-
G10W		1,00	1,00	0,75	-	-	-	-	-
G12W		1,00	1,00	0,75	-	-	-	-	-
G6W..HT		1,00	1,00	1,00	1,00	1,00	0,85	0,75	0,65
G8W..HT		1,00	1,00	1,00	1,00	1,00	0,85	0,75	0,65
G10W..HT		1,00	1,00	1,00	1,00	1,00	0,85	0,75	0,65
G12W..HT		1,00	1,00	1,00	1,00	1,00	0,85	0,75	0,65

G4OS-GC-GW-derating-en_a_te

EXAMPLE 1

A 2,2 kW G4OS motor is to be used in 50°C water.

Motor power at 50 °C = 2,2 x 0,7 = 1,54 kW

EXAMPLE 2

A 2,2 kW G4C motor is to be used in 50°C water.

Motor power at 50 °C = 2,2 x 0,85 = 1,87 kW

EXAMPLE 3

A 7,5 kW G6C motor is to be used in 45°C water.

Motor power at 50 °C = 7,5 x 0,8 = 6 kW

EXAMPLE 4

A 15 kW G6W motor is to be used in 35°C water.

Motor power at 35 °C = 15 x 0,75 = 11,25 kW

SELECTING CABLE CROSS-SECTIONS FOR SUBMERSIBLE MOTORS

To select the cross-section of power cables for submersible pumps, consult the tables shown below. In these tables, the maximum lengths of the power cable for each cross-section are shown for each motor and next to the various input voltage ratings.

Therefore, to find the required cable cross-section, simply read off the maximum permitted lengths for each cross-section next to the selected motor and required input voltage.

E.g.:

A 120 m long power cable must be matched with a 230V G4C07M235 motor.

To determine the cross-section of the cable, simply move along the row of the 230V motor until you find the maximum length of 120 m or immediately above it and then read off the corresponding cross-section in that column.

In this case, the 4 mm² cable is selected.

N.B.: the tables include specific data (current and power factor) for each motor and voltage rating based on a maximum voltage drop of 4% (HD 384.5), a maximum cable temperature of 90°C, water installation similar to air installation at a temperature of 30°C.

CABLE TYPES

SECTION mm ²	THREE CORE FLAT					FOUR CORE FLAT					SINGLE CORE ROUND			FOUR CORE ROUND		
	Hmin mm	Lmin mm	Hmax mm	Lmax mm	Weight kg/km	Hmin mm	Lmin mm	Hmax mm	Lmax mm	Weight kg/km	Dmin mm	Dmax mm	Weight kg/km	Dmin mm	Dmax mm	Weight kg/km
4	8	19,2	9	20,8	250	8	25,2	9	26,8	395	6,5	7,5	92	14	16,1	360
6	8	19,2	9	20,8	325	8	25,2	9	26,8	470	7,4	8	118	15,7	18	475
10	8	19,2	9	20,8	535	8	25,2	9	26,8	710	8,6	10	183	20,9	23,9	836
16	-	-	-	-	-	-	-	-	-	-	9,6	11	251	23,8	27,1	1145
25	-	-	-	-	-	-	-	-	-	-	11	13	362	28,9	32,9	1716
35	-	-	-	-	-	-	-	-	-	-	12,5	14,5	497	-	-	-
50	-	-	-	-	-	-	-	-	-	-	15	17	669	-	-	-
70	-	-	-	-	-	-	-	-	-	-	17,5	19,5	901	-	-	-
95	-	-	-	-	-	-	-	-	-	-	20,5	22,5	1141	-	-	-
120	-	-	-	-	-	-	-	-	-	-	22	24,4	1435	-	-	-
150	-	-	-	-	-	-	-	-	-	-	25,2	28,3	1795	-	-	-
185	-	-	-	-	-	-	-	-	-	-	27,6	31	2156	-	-	-
240	-	-	-	-	-	-	-	-	-	-	30,6	34,5	2760	-	-	-

L-cavi-en_a_td

G4OS SINGLE-PHASE, 50 Hz: SIZING OF ETHYLENE-PROPILENE (EPR) CABLES, DOL (DIRECT ON LINE) STARTING

MOTOR TYPE SINGLE-PHASE	RATED POWER Kw HP		RATED VOLTAGE V	Cos φ	RATED CURRENT A	VOLTAGE DROP %	Cable cross section: 4G x ...mm ²												
							mm ²	1,5	2,5	4	6	10	16	25	35				
							A max	23	32	42	54	75	100	127	158				
Maximum length in metres																			
G4OS03M235	0,37	0,5	220	0,98	3,01	4													
			230	0,96	3,06			107	179	288	432								
			240	0,93	3,16														
G4OS05M235	0,55	0,75	220	0,98	4,07														
			230	0,96	4,13			79	132	213	319								
			240	0,92	4,25														
G4OS07M235	0,75	1	220	0,99	5,44														
			230	0,97	5,45			58	98	158	237	409							
			240	0,94	5,58														
G4OS11M235	1,1	1,5	220	0,99	7,45														
			230	0,98	7,37			42	71	115	172	298	469						
			240	0,95	7,55														
G4OS15M235	1,5	2	220	0,98	10,0														
			230	0,96	10,1		31	53	86	129	223	351	542						
			240	0,92	10,5														
G4OS22M235	2,2	3	220	0,99	14,3														
			230	0,97	14,1		20	36	58	89	154	244	377	528					
			240	0,94	14,4														
G4OS40M235	4	5,5	220	0,96	25,7														
			230	0,94	24,9		-	18	31	49	86	137	212	296					
			240	0,92	24,8														

Exposed cable laid at a temperature of 30°C, maximum conductor temperature of 90°C

G4osm-b-cavi-50-en_a_te

G4OS THREE-PHASE, 50 Hz: SIZING OF ETHYLENE-PROPYLENE (EPR) CABLES, DOL (DIRECT ON LINE) STARTING

MOTOR TYPE THREE-PHASE	RATED POWER Kw HP		RATED VOLTAGE V	Cos φ	RATED CURRENT A	VOLTAGE DROP %	Cable cross section: 4G x ...mm ²								
							mm ²	1,5	2,5	4	6	10	16	25	35
							A max	23	32	42	54	75	100	127	158
Maximum length in metres															
G4OS03T235	0,37	0,5	220	0,78	2,04	4		229	381						
			230	0,72	2,08										
			240	0,68	2,15										
G4OS05T235	0,55	0,75	220	0,80	2,79	4		163	271						
			230	0,75	2,86										
			240	0,71	2,96										
G4OS07T235	0,75	1	220	0,78	3,76	4		124	206	331					
			230	0,71	3,95										
			240	0,67	4,16										
G4OS11T235	1,1	1,5	220	0,80	5,06	4		89	149	240	358				
			230	0,74	5,18										
			240	0,70	5,42										
G4OS15T235	1,5	2	220	0,78	6,95	4		66	110	178	266	455			
			230	0,72	7,24										
			240	0,68	7,64										
G4OS22T235	2,2	3	220	0,80	9,72	4		45	76	123	185	317			
			230	0,74	10,0										
			240	0,69	10,5										
G4OS30T235	3	4	220	0,85	12,1	4		33	57	93	140	241	376		
			230	0,81	12,0										
			240	0,77	12,3										
G4OS40T235	4	5,5	220	0,85	16,4	4		23	41	67	102	177	277		
			230	0,80	16,5										
			240	0,76	17,0										
G4OS55T235	5,5	7,5	220	0,83	22,9	4		-	28	48	73	128	201		
			230	0,78	23,0										
			240	0,73	23,7										
G4OS75T235	7,5	10	220	0,82	31,0	4		-	19	34	53	94	148		
			230	0,76	31,4										
			240	0,71	32,4										
G4OS03T405	0,37	0,5	380	0,78	1,18	4		685							
			400	0,72	1,20										
			415	0,68	1,24										
G4OS05T405	0,55	0,75	380	0,80	1,61	4		489							
			400	0,75	1,65										
			415	0,71	1,71										
G4OS07T405	0,75	1	380	0,78	2,20	4		367							
			400	0,71	2,30										
			415	0,67	2,40										
G4OS11T405	1,1	1,5	380	0,80	2,90	4		271	451						
			400	0,74	3,00										
			415	0,70	3,10										
G4OS15T405	1,5	2	380	0,78	4,00	4		201	334						
			400	0,72	4,20										
			415	0,68	4,40										
G4OS22T405	2,2	3	380	0,80	5,60	4		139	232	374					
			400	0,74	5,80										
			415	0,69	6,10										
G4OS30T405	3	4	380	0,85	7,00	4		104	174	281	421				
			400	0,81	7,00										
			415	0,77	7,10										
G4OS40T405	4	5,5	380	0,85	9,50	4		75	127	206	309				
			400	0,80	9,50										
			415	0,76	9,80										
G4OS55T405	5,5	7,5	380	0,83	13,2	4		53	92	150	226	389			
			400	0,78	13,3										
			415	0,73	13,7										
G4OS75T405	7,5	10	380	0,82	17,9	4		37	66	109	166	288	451		
			400	0,76	18,1										
			415	0,71	18,7										

Exposed cable laid at a temperature of 30°C, maximum conductor temperature of 90°C

G4os-b-cavi-50-en_a_te

G4C SINGLE-PHASE, 50 Hz: SIZING OF ETHYLENE-PROPILENE (EPR) CABLES, DOL (DIRECT ON LINE) STARTING

MOTOR TYPE SINGLE-PHASE	RATED POWER Kw HP		RATED VOLTAGE V	Cos φ	RATED CURRENT A	VOLTAGE DROP %	Cable cross section: 4G x ...mm ² (2W: 3G x ...mm ²)												
							mm ²	1,5	2,5	4	6	10	16	25	35				
							A max	23	32	42	54	75	100	127	158				
Maximum lenght in metres																			
G4C03M235	0,37	0,5	220	0,96	3,20	4													
			230	0,97	3,30			103	172	278	416								
			240	0,91	3,40														
G4C05M235	0,55	0,75	220	0,95	4,30														
			230	0,94	4,60			76	127	205	307								
			240	0,90	4,80														
G4C07M235	0,75	1	220	0,93	6,00														
			230	0,92	6,20			57	96	155	232	398							
			240	0,85	6,50														
G4C11M235	1,1	1,5	220	0,94	8,10														
			230	0,92	8,10			40	68	110	166	286	448						
			240	0,87	8,30														
G4C15M235	1,5	2	220	0,96	10,4														
			230	0,93	10,4		30	52	84	126	218	343	527						
			240	0,90	10,7														
G4C22M235	2,2	3	220	0,96	15,4														
			230	0,94	15,0		19	34	56	84	146	231	355	496					
			240	0,91	15,3														
G4C40M235	4	5,5	220	0,93	29,9														
			230	0,90	29,8		-	15	27	42	75	120	185	259					
			240	0,87	29,7														

Exposed cable laid at a temperature of 30°C, maximum conductor temperature of 90°C

G4cm-cavi-50-en_a_te

G4C THREE-PHASE, 50 Hz: SIZING OF ETHYLENE-PROPILENE (EPR) CABLES, DOL (DIRECT ON LINE) STARTING

MOTOR TYPE THREE-PHASE	RATED POWER		RATED VOLTAGE V	Cos φ	RATED CURRENT A	VOLTAGE DROP %	Cable cross section: 4G x ...mm ²															
	Kw	HP					mm ²	1,5	2,5	4	6	10	16	25	35							
							A max	23	32	42	54	75	100	127	158							
Maximum lenght in metres																						
G4C03T235	0,37	0,5	220	0,69	2,60	4																
			230	0,70	2,70			190	316													
			240	0,67	3,10																	
G4C05T235	0,55	0,75	220	0,77	3,10																	
			230	0,71	3,30			152	253	407												
			240	0,66	3,50																	
G4C07T235	0,75	1	220	0,77	4,00																	
			230	0,73	4,10			118	196	315												
			240	0,66	4,50																	
G4C11T235	1,1	1,5	220	0,80	5,60																	
			230	0,76	5,70			80	134	216	323											
			240	0,73	6,20																	
G4C15T235	1,5	2	220	0,77	7,40																	
			230	0,72	7,60			62	105	169	253	433										
			240	0,68	8,00																	
G4C22T235	2,2	3	220	0,80	10,0																	
			230	0,78	10,2			43	74	120	180	308										
			240	0,70	10,7																	
G4C30T235	3	4	220	0,77	13,7																	
			230	0,71	14,3			32	55	90	135	232	362									
			240	0,68	15,2																	
G4C40T235	4	5,5	220	0,81	16,4																	
			230	0,79	17,3			24	43	71	108	187	292	443								
			240	0,74	18,2																	
G4C55T235	5,5	7,5	220	0,79	23,4																	
			230	0,74	24,2			-	29	49	75	131	205	312								
			240	0,70	25,0																	
G4C03T405	0,37	0,5	380	0,69	1,50																	
			400	0,70	1,60			569														
			415	0,67	1,80																	
G4C05T405	0,55	0,75	380	0,77	1,80																	
			400	0,71	1,90		454															
			415	0,66	2,00																	
G4C07T405	0,75	1	380	0,77	2,30																	
			400	0,73	2,40		355															
			415	0,66	2,60																	
G4C11T405	1,1	1,5	380	0,80	3,30																	
			400	0,76	3,40		238	396														
			415	0,73	3,60																	
G4C15T405	1,5	2	380	0,77	4,30																	
			400	0,72	4,40		189	315														
			415	0,68	4,60																	
G4C22T405	2,2	3	380	0,80	5,80																	
			400	0,78	5,90		134	224	361													
			415	0,70	6,20																	
G4C30T405	3	4	380	0,77	7,90																	
			400	0,71	8,30		101	169	273	409												
			415	0,68	8,80																	
G4C40T405	4	5,5	380	0,81	9,50																	
			400	0,79	10,0		80	136	221	331												
			415	0,74	10,5																	
G4C55T405	5,5	7,5	380	0,79	13,5																	
			400	0,74	14,0		54	94	153	231	398											
			415	0,70	14,5																	
G4C75T405	7,5	10	380	0,84	17,0																	
			400	0,79	17,4		-	68	113	172	297	466										
			415	0,75	18,1																	

Exposed cable laid at a temperature of 30°C, maximum conductor temperature of 90°C

G4c-cavi-50-en_a_te

G6C, 50 Hz: SIZING OF ETHYLENE-PROPILENE (EPR) CABLES DOL (DIRECT ON LINE) STARTING

MOTOR TYPE THREE-PHASE	RATED POWER Kw HP		RATED VOLTAGE V	Cos φ	RATED CURRENT A	VOLTAGE DROP %	Cable cross section: 4G x ...mm ²														
							mm ²	4	6	10	16	25	35	50	70						
							A max	42	54	75	100	127	158	192	246						
Maximum length in metres																					
G6C40T235	4	5,5	220	0,80	17,8	4															
			230	0,75	18,4			65	99	171	268	406	559								
			240	0,70	19,1																
G6C55T235	5,5	7,5	220	0,80	24,1	4															
			230	0,75	24,2			47	72	125	197	300	413	572							
			240	0,71	25,3																
G6C75T235	7,5	10	220	0,82	30,5	4															
			230	0,78	31,2			34	54	95	151	231	320	444							
			240	0,73	31,7																
G6C93T235	9,3	12,5	220	0,82	37,6	4															
			230	0,80	38,1			26	42	76	121	186	258	359	489						
			240	0,79	39,5																
G6C110T235	11	15	220	0,87	43,3	4															
			230	0,82	44,2			-	33	61	99	153	214	299	412						
			240	0,79	45,0																
G6C150T235	15	20	220	0,84	58,0	4															
			230	0,80	57,9			-	-	44	73	115	161	226	311						
			240	0,76	59,2																
G6C185T235	18,5	25	220	0,83	70,1	4															
			230	0,80	71,0			-	-	35	59	94	133	187	257						
			240	0,73	72,7																
G6C220T235	22	30	220	0,88	82,3	4															
			230	0,84	81,4			-	-	-	46	74	106	152	212						
			240	0,80	82,3																
G6C40T405	4	5,5	380	0,80	10,3	4															
			400	0,75	10,6			201	301	517											
			415	0,70	11,0																
G6C55T405	5,5	7,5	380	0,80	13,9	4															
			400	0,75	14,0			147	222	382											
			415	0,71	14,6																
G6C75T405	7,5	10	380	0,82	17,6	4															
			400	0,78	18,0			112	169	293	459										
			415	0,73	18,3																
G6C93T405	9,3	12,5	380	0,82	21,7	4															
			400	0,80	22,0			88	135	236	371	565									
			415	0,79	22,8																
G6C110T405	11	15	380	0,87	25,0	4															
			400	0,82	25,5			71	110	193	305	466									
			415	0,79	26,0																
G6C150T405	15	20	380	0,84	33,5	4															
			400	0,80	33,4			51	81	145	231	355	493								
			415	0,76	34,2																
G6C185T405	18,5	25	380	0,83	40,5	4															
			400	0,80	41,0			-	65	119	191	294	409								
			415	0,73	42,0																
G6C220T405	22	30	380	0,88	47,5	4															
			400	0,84	47,0			-	50	94	153	237	332	467							
			415	0,80	47,5																
G6C300T405	30	40	380	0,89	63,0	4															
			400	0,85	61,5			-	-	65	109	173	245	346	480						
			415	0,80	63,5																
G6C370T405	37	50	380	0,87	79,5	4															
			400	0,84	79,3			-	-	-	84	135	193	274	381						
			415	0,80	80,0																

Exposed cable laid at a temperature of 30°C, maximum conductor temperature of 90°C

G6c-cavi-50-en_a_te

G6C, 50 Hz: SIZING OF ETHYLENE-PROPILENE (EPR) CABLES Y/ Δ (STAR / DELTA) STARTING

MOTOR TYPE THREE-PHASE	RATED POWER Kw HP		RATED VOLTAGE V	Cos ϕ	RATED CURRENT A	VOLTAGE DROP %	Cable cross section: 4G x ...mm ² + 3 x ...mm ²								
							mm ²	4	6	10	16	25	35	50	70
							A max*	73	94	130	173	220	274	333	426
Maximum lenght in metres															
G6C40T405	4	5,5	380	0,80	10,3	4									
			400	0,75	10,6			352	525						
			415	0,70	11,0										
G6C55T405	5,5	7,5	380	0,80	13,9										
			400	0,75	14,0			259	388						
			415	0,71	14,6										
G6C75T405	7,5	10	380	0,82	17,6										
			400	0,78	18,0			199	299	513					
			415	0,73	18,3										
G6C93T405	9,3	12,5	380	0,82	21,7										
			400	0,80	22,0			160	241	415					
			415	0,79	22,8										
G6C110T405	11	15	380	0,87	25,0										
			400	0,82	25,5		130	197	340	533					
			415	0,79	26,0										
G6C150T405	15	20	380	0,84	33,5										
			400	0,80	33,4		98	150	260	408					
			415	0,76	34,2										
G6C185T405	18,5	25	380	0,83	40,5										
			400	0,80	41,0		80	123	216	340	518				
			415	0,73	42,0										
G6C220T405	22	30	380	0,88	47,5										
			400	0,84	47,0		63	98	173	274	421				
			415	0,80	47,5										
G6C300T405	30	40	380	0,89	63,0										
			400	0,85	61,5		44	70	126	202	312	435			
			415	0,80	63,5										
G6C370T405	37	50	380	0,87	79,5										
			400	0,84	79,3		-	53	99	160	248	347	487		
			415	0,80	80,0										

Exposed cable laid at a temperature of 30°C, maximum conductor temperature of 90°C

G6c-cavi-SD-50-en_a_te

*A max is the maximum rated current of the motor

G6W, 50 Hz: SIZING OF ETHYLENE-PROPILENE (EPR) CABLES DOL (DIRECT ON LINE) STARTING

MOTOR TYPE THREE-PHASE	RATED POWER Kw HP		RATED VOLTAGE V	Cos φ	RATED CURRENT A	VOLTAGE DROP %	Cable cross section: 4G x ...mm ²											
							mm ²	4	6	10	16	25	35	50	70			
							A max	42	54	75	100	127	158	192	246			
Maximum length in metres																		
G6W40T405	4	5,5	380	0,90	9,89	4		187	281	484								
			415	0,85	9,13													
G6W55T405	5,5	7,5	380	0,88	12,7			148	222	384								
			415	0,82	12,5													
G6W75T405	7,5	10	380	0,90	17,0			106	161	279	439							
			415	0,84	16,2													
G6W93T405	9,3	12,5	380	0,89	20,5			87	133	233	366	561						
			415	0,83	19,9													
G6W110T405	11	15	380	0,90	24,2			71	110	194	306	470						
			415	0,84	23,4													
G6W130T405	13	17,5	380	0,90	28,1			60	93	165	262	403	561					
			415	0,85	27,0													
G6W150T405	15	20	380	0,88	32,1			52	82	146	233	358	498					
			415	0,82	31,3													
G6W185T405	18,5	25	380	0,89	38,5			-	65	118	190	294	410					
			415	0,83	37,5													
G6W220T405	22	30	380	0,87	47,3			-	51	95,1	155	241	337	472				
			415	0,80	46,7													
G6W260T405	26	35	380	0,85	56,5		-	-	78	129	202	284	398					
			415	0,79	55,7													
G6W300T405	30	40	380	0,87	63,8		-	-	66	110	174	245	346	479				
			415	0,81	62,0													
G6W370T405	37	50	380	0,86	81,8		-	-	-	82	132	188	267	372				
			415	0,80	79,4													

Exposed cable laid at a temperature of 30°C, maximum conductor temperature of 90°C

G6w-cavi-50-en_a_te

G6W HT, 50 Hz: SIZING OF ETHYLENE-PROPILENE (EPR) CABLES DOL (DIRECT ON LINE) STARTING

MOTOR TYPE THREE-PHASE	RATED POWER Kw HP		RATED VOLTAGE V	Cos φ	RATED CURRENT A	VOLTAGE DROP %	Cable cross section: 4G x ...mm ²											
							mm ²	4	6	10	16	25	35	50	70			
							A max	42	54	75	100	127	158	192	246			
Maximum length in metres																		
G6W40T405 HT	4	5,5	380	0,81	9,81	4		209	313	537								
			415	0,72	10,5													
G6W55T405 HT	5,5	7,5	380	0,84	12,9			152	229	394								
			415	0,75	13,4													
G6W75T405 HT	7,5	10	380	0,85	16,9			113	171	296	464							
			415	0,77	17,3													
G6W93T405 HT	9,3	12,5	380	0,87	20,6			89	135	236	372	568						
			415	0,79	20,8													
G6W110T405 HT	11	15	380	0,88	23,8			74	115	201	317	486						
			415	0,80	23,9													
G6W130T405 HT	13	17,5	380	0,85	28,3			63	98	173	273	419	580					
			415	0,78	28,4													
G6W150T405 HT	15	20	380	0,86	31,8			-	84	151	240	368	511					
			415	0,78	32,5													
G6W185T405 HT	18,5	25	380	0,83	40,3			-	66	120	192	296	411					
			415	0,75	41,6													
G6W220T405 HT	22	30	380	0,82	48,5			-	52,2	97,5	158	246	342	477				
			415	0,74	49,7													
G6W260T405 HT	26	35	380	0,85	55,7		-	-	80	131	205	288	404					
			415	0,77	55,8													
G6W300T405 HT	30	40	380	0,79	68,6		-	-	65	110	173	243	341	467				
			415	0,67	75,2													

Exposed cable laid at a temperature of 30°C, maximum conductor temperature of 90°C

G6w-ht-cavi-50-en_a_te

G6W, 50 Hz: SIZING OF ETHYLENE-PROPILENE (EPR) CABLES Y/ Δ (STAR / DELTA) STARTING

MOTOR TYPE THREE-PHASE	RATED POWER Kw HP		RATED VOLTAGE V	Cos ϕ	RATED CURRENT A	VOLTAGE DROP %	Cable cross section: 4G x ...mm ² + 3 x ...mm ²											
							mm ²	4	6	10	16	25	35	50	70			
							A max*	73	94	130	173	220	274	333	426			
Maximum lenght in metres																		
G6W40T405	4	5,5	380	0,90	9,89	4		-	-									
			415	0,85	9,13													
G6W55T405	5,5	7,5	380	0,88	12,7			260	389									
			415	0,82	12,5													
G6W75T405	7,5	10	380	0,90	17,0			189	283	488								
			415	0,84	16,2													
G6W93T405	9,3	12,5	380	0,89	20,5			157	237	408								
			415	0,83	19,9													
G6W110T405	11	15	380	0,90	24,2			131	197	341	535							
			415	0,84	23,4													
G6W130T405	13	17,5	380	0,90	28,1			111	169	293	460							
			415	0,85	27,0													
G6W150T405	15	20	380	0,88	32,1			99	150	261	410							
			415	0,82	31,3													
G6W185T405	18,5	25	380	0,89	38,5			80	122	214	337	517						
			415	0,83	37,5													
G6W220T405	22	30	380	0,87	47,3			64	99,5	176	278	426						
			415	0,80	46,7													
G6W260T405	26	35	380	0,85	56,5			53	83	148	236	362	502					
			415	0,79	55,7													
G6W300T405	30	40	380	0,87	63,8		44	70,2	127	203	313	436						
			415	0,81	62,0													
G6W370T405	37	50	380	0,86	81,8		-	52	96	157	243	340	476					
			415	0,80	79,4													

Exposed cable laid at a temperature of 30°C, maximum conductor temperature of 90°C

G6W-cavi-SD-50-en_a_te

*A max is the maximum rated current of the motor

G6W HT, 50 Hz: SIZING OF ETHYLENE-PROPILENE (EPR) CABLES Y/ Δ (STAR / DELTA) STARTING

MOTOR TYPE THREE-PHASE	RATED POWER Kw HP		RATED VOLTAGE V	Cos ϕ	RATED CURRENT A	VOLTAGE DROP %	Cable cross section: 4G x ...mm ² + 3 x ...mm ²											
							mm ²	4	6	10	16	25	35	50	70			
							A max*	73	94	130	173	220	274	333	426			
Maximum lenght in metres																		
G6W40T405 HT	4	5,5	380	0,81	9,81	4		365	545									
			415	0,72	10,5													
G6W55T405 HT	5,5	7,5	380	0,84	12,9			267	400									
			415	0,75	13,4													
G6W75T405 HT	7,5	10	380	0,85	16,9			200	301	517								
			415	0,77	17,3													
G6W93T405 HT	9,3	12,5	380	0,87	20,6			160	240	414								
			415	0,79	20,8													
G6W110T405 HT	11	15	380	0,88	23,8			136	205	354	555							
			415	0,80	23,9													
G6W130T405 HT	13	17,5	380	0,85	28,3			117	177	306	480							
			415	0,78	28,4													
G6W150T405 HT	15	20	380	0,86	31,8			102	155	269	422							
			415	0,78	32,5													
G6W185T405 HT	18,5	25	380	0,83	40,3			81	124	217	342	521						
			415	0,75	41,6													
G6W220T405 HT	22	30	380	0,82	48,5			66	102	180	285	435						
			415	0,74	49,7													
G6W260T405 HT	26	35	380	0,85	55,7			54	84	150	239	367	509					
			415	0,77	55,8													
G6W300T405 HT	30	40	380	0,79	68,6		-	70,4	128	204	314	434						
			415	0,67	75,2													

Exposed cable laid at a temperature of 30°C, maximum conductor temperature of 90°C

G6w-ht-cavi-50-en_a_te

*A max is the maximum rated current of the motor

G8W, 50 Hz: SIZING OF ETHYLENE-PROPILENE (EPR) CABLES DOL (DIRECT ON LINE) STARTING

MOTOR TYPE THREE-PHASE	RATED POWER Kw HP		RATED VOLTAGE V	Cos φ	RATED CURRENT A	VOLTAGE DROP %	Cable cross section: 1 x ...mm ²									
							mm2	10	16	25	35	50	70	95	120	
							A max	75	100	127	158	192	246	298	346	
Maximum lenght in metres																
G8W300T405	30	40	380	0,88	64,5	4		64	107	170	240	340	471			
			415	0,85	60,1											
G8W370T405	37	50	380	0,88	80,0			47	82	133	190	270	376	481		
			415	0,85	74,8											
G8W450T405	45	60	380	0,88	95,9			-	65	106	154	221	311	398	494	
			415	0,85	88,6											
G8W520T405	52	70	380	0,87	110			-	-	90	132	191	270	346	429	
			415	0,82	105											
G8W550T405	55	75	380	0,88	118			-	-	81	120	175	248	320	398	
			415	0,84	111											
G8W600T405	60	80	380	0,87	127			-	-	74	111	162	230	297	369	
			415	0,83	121											
G8W670T405	67	90	380	0,87	140		-	-	-	97	144	206	267	333		
			415	0,84	132											
G8W750T405	75	100	380	0,87	155		-	-	-	85	127	183	239	298		
			415	0,83	148											
G8W830T405	83	110	380	0,88	171		-	-	-	-	111	162	213	267		
			415	0,84	162											
G8W930T405	93	125	380	0,88	189		-	-	-	-	97	144	190	239		
			415	0,84	179											

Exposed cable laid at a temperature of 30°C, maximum conductor temperature of 90°C

G8w-cavi-50-en_a_te

G8W HT, 50 Hz: SIZING OF ETHYLENE-PROPILENE (EPR) CABLES DOL (DIRECT ON LINE) STARTING

MOTOR TYPE THREE-PHASE	RATED POWER Kw HP		RATED VOLTAGE V	Cos φ	RATED CURRENT A	VOLTAGE DROP %	Cable cross section: 1 x ...mm ²									
							mm2	10	16	25	35	50	70	95	120	
							A max	75	100	127	158	192	246	298	346	
Maximum lenght in metres																
G8W300T405 HT	30	40	380	0,87	63,7	4		66	110	174	246	347	480			
			415	0,82	62,2											
G8W370T405 HT	37	50	380	0,88	77,0			-	86	139	198	281	392	500		
			415	0,83	73,7											
G8W450T405 HT	45	60	380	0,86	94,7			-	-	110	159	228	319	407	502	
			415	0,80	92,8											
G8W520T405 HT	52	70	380	0,88	111			-	-	88	130	188	265	342	424	
			415	0,83	106											
G8W550T405 HT	55	75	380	0,86	116			-	-	85	125	181	256	328	407	
			415	0,81	112											
G8W600T405 HT	60	80	380	0,87	125			-	-	-	113	165	234	302	375	
			415	0,82	119											
G8W670T405 HT	67	90	380	0,87	137		-	-	-	100	147	211	273	341		
			415	0,81	134											
G8W750T405 HT	75	100	380	0,87	153		-	-	-	86	129	186	242	303		
			415	0,83	147											
G8W830T405 HT	83	110	380	0,87	168		-	-	-	-	114	167	218	273		
			415	0,83	162											

Exposed cable laid at a temperature of 30°C, maximum conductor temperature of 90°C

G8w-ht-cavi-50-en_a_te

G8W, 50 Hz: SIZING OF ETHYLENE-PROPILENE (EPR) CABLES Y/ Δ (STAR / DELTA) STARTING

MOTOR TYPE THREE-PHASE	RATED POWER Kw HP		RATED VOLTAGE V	Cos ϕ	RATED CURRENT A	VOLTAGE DROP %	Cable cross section: 1 x ...mm ²								
							mm ²	6	10	16	25	35	50	70	95
							A max*	94	130	173	220	274	333	426	516
Maximum lenght in metres															
G8W300T405	30	40	380	0,88	64,5	4		69	124	199	307	428			
			415	0,85	60,1										
G8W370T405	37	50	380	0,88	80,0			52	97	157	245	342	481		
			415	0,85	74,8										
G8W450T405	45	60	380	0,88	95,9			-	78	128	201	283	399		
			415	0,85	88,6										
G8W520T405	52	70	380	0,87	110			-	66	110	175	246	348	481	
			415	0,82	105										
G8W550T405	55	75	380	0,88	118			-	59	101	160	227	321	445	
			415	0,84	111										
G8W600T405	60	80	380	0,87	127			-	54	93	148	211	299	415	528
			415	0,83	121										
G8W670T405	67	90	380	0,87	140			-	-	82	132	189	269	374	477
			415	0,84	132										
G8W750T405	75	100	380	0,87	155			-	-	72	117	169	241	336	430
			415	0,83	148										
G8W830T405	83	110	380	0,88	171		-	-	62,1	103	149	214	301	386	
			415	0,84	162										
G8W930T405	93	125	380	0,88	189		-	-	54	90	132	191	270	348	
			415	0,84	179										

Exposed cable laid at a temperature of 30°C, maximum conductor temperature of 90°C

G8w-cavi-SD-50-en_a_te

*A max is the maximum rated current of the motor

G8W HT, 50 Hz: SIZING OF ETHYLENE-PROPILENE (EPR) CABLES Y/ Δ (STAR / DELTA) STARTING

MOTOR TYPE THREE-PHASE	RATED POWER Kw HP		RATED VOLTAGE V	Cos ϕ	RATED CURRENT A	VOLTAGE DROP %	Cable cross section: 1 x ...mm ² + 3 x ...mm ²								
							mm ²	6	10	16	25	35	50	70	95
							A max*	94	130	173	220	274	333	426	516
Maximum lenght in metres															
G8W300T405 HT	30	40	380	0,87	63,7	4		70	127	203	314	437			
			415	0,82	62,2										
G8W370T405 HT	37	50	380	0,88	77,0			55	101	164	255	356	500		
			415	0,83	73,7										
G8W450T405 HT	45	60	380	0,86	94,7			-	81	133	208	291	409		
			415	0,80	92,8										
G8W520T405 HT	52	70	380	0,88	111			-	64	108	171	242	342	474	
			415	0,83	106										
G8W550T405 HT	55	75	380	0,86	116			-	62	105	166	235	331	458	
			415	0,81	112										
G8W600T405 HT	60	80	380	0,87	125			-	-	95	151	214	304	421	536
			415	0,82	119										
G8W670T405 HT	67	90	380	0,87	137			-	-	84	136	194	275	383	488
			415	0,81	134										
G8W750T405 HT	75	100	380	0,87	153			-	-	73	119	171	244	341	435
			415	0,83	147										
G8W830T405 HT	83	110	380	0,87	168		-	-	-	106	154	220	309	395	
			415	0,83	162										

Exposed cable laid at a temperature of 30°C, maximum conductor temperature of 90°C

G8w-ht-cavi-SD-50-en_a_t

*A max is the maximum rated current of the motor

G10W, 50 Hz: SIZING OF ETHYLENE-PROPILENE (EPR) CABLES DOL (DIRECT ON LINE) STARTING

MOTOR TYPE THREE-PHASE	RATED POWER Kw HP		RATED VOLTAGE V	Cos φ	RATED CURRENT A	VOLTAGE DROP %	Cable cross section: 1 x ...mm ²								
							mm ²	50	70	95	120	150	185	240	300
							A max	192	246	298	346	399	456	538	621
Maximum length in metres															
G10W930T405	93	125	380	0,87	191	4		96	143	188	237	286	336	411	477
			415	0,81	186										
G10W1100T405	110	150	380	0,87	221			-	118	158	201	244	287	352	410
			415	0,83	212										
G10W1300T405	130	175	380	0,87	262			-	-	128	164	201	238	294	343
			415	0,81	254										
G10W1500T405	150	200	380	0,87	298			-	-	108	140	173	206	255	299
			415	0,83	287										

Exposed cable laid at a temperature of 30°C, maximum conductor temperature of 90°C

G10w-cavi-50-en_a_te

MOTOR TYPE THREE-PHASE	RATED POWER Kw HP		RATED VOLTAGE V	Cos φ	RATED CURRENT A	VOLTAGE DROP %	Cable cross section: 1 x ...mm ²								
							mm ²	50	70	95	120	150	185	240	300
							A max	192	246	298	346	399	456	538	621
Maximum length in metres															
G10W830T405 HT	83	100	380	0,86	172	4		111	163	213	267	321	375	456	528
			415	0,79	170										
G10W930T405 HT	93	125	380	0,86	189			-	145	191	241	290	339	413	479
			415	0,81	185										
G10W1100T405 HT	110	150	380	0,85	225			-	117	156	198	240	281	343	398
			415	0,78	224										
G10W1300T405 HT	130	175	380	0,87	261			-	-	129	165	202	239	295	344
			415	0,80	256										

Exposed cable laid at a temperature of 30°C, maximum conductor temperature of 90°C

G10w-ht-cavi-50-en_a_te

G10W - L10W HT, 50 Hz: SIZING OF ETHYLENE-PROPILENE (EPR) CABLES Y/Δ (STAR / DELTA) STARTING

MOTOR TYPE THREE-PHASE	RATED POWER Kw HP		RATED VOLTAGE V	Cos φ	RATED CURRENT A	VOLTAGE DROP %	Cable cross section: 1 x ...mm ²								
							mm ²	25	35	50	70	95	120	150	185
							A max*	220	274	333	426	516	599	691	790
Maximum length in metres															
G10W930T405	93	125	380	0,87	191	4		90	132	191	269	345	428	511	
			415	0,81	186										
G10W1100T405	110	150	380	0,87	221			-	110	161	229	295	367	439	512
			415	0,83	212										
G10W1300T405	130	175	380	0,87	262			-	88	131	189	245	306	368	429
			415	0,81	254										
G10W1500T405	150	200	380	0,87	298			-	-	111	162	212	266	321	375
			415	0,83	287										

Exposed cable laid at a temperature of 30°C, maximum conductor temperature of 90°C

G10w-cavi-SD-50-en_a_te

*A max is the maximum rated current of the motor

MOTOR TYPE THREE-PHASE	RATED POWER Kw HP		RATED VOLTAGE V	Cos φ	RATED CURRENT A	VOLTAGE DROP %	Cable cross section: 1 x ...mm ²								
							mm ²	25	35	50	70	95	120	150	185
							A max*	220	274	333	426	516	599	691	790
Maximum length in metres															
G10W830T405 HT	83	100	380	0,86	172	4		104	151	216	303	387	478	569	
			415	0,79	170										
G10W930T405 HT	93	125	380	0,86	189			92	135	194	273	350	434	517	600
			415	0,81	185										
G10W1100T405 HT	110	150	380	0,85	225			-	109	160	227	292	362	432	501
			415	0,78	224										
G10W1300T405 HT	130	175	380	0,87	261			-	88	131	189	246	308	369	431
			415	0,80	256										

Exposed cable laid at a temperature of 30°C, maximum conductor temperature of 90°C

G10w-ht-cavi-SD-50-en_a_te

*A max is the maximum rated current of the motor

G12W - G12W HT, 50 Hz: SIZING OF ETHYLENE-PROPILENE (EPR) CABLES DOL (DIRECT ON LINE) STARTING

MOTOR TYPE THREE-PHASE	RATED POWER Kw HP		RATED VOLTAGE V	Cos φ	RATED CURRENT A	VOLTAGE DROP %	Cable cross section: 1 x ...mm ²								
							mm ²	50	70	95	120	150	185	240	300
							A max	192	246	298	346	399	456	538	621
Maximum length in metres															
G12W1850T405	185	250	380	0,86	378	4	-	-	-	-	129	155	195	229	
			415	0,85	349		-	-	-	-	-	-	-		
G12W2200T405	220	300	380	0,87	438		-	-	-	-	-	129	164	195	
			415	0,84	413		-	-	-	-	-	-	-		
G12W2600T405	260	350	380	0,88	512		-	-	-	-	-	104	136	164	
			415	0,85	475		-	-	-	-	-	-	-		
G12W3000T405	300	400	380	0,82	621		-	-	-	-	-	-	-	-	
			415	0,73	640		-	-	-	-	-	-	-		

Exposed cable laid at a temperature of 30°C, maximum conductor temperature of 90°C

G12w-cavi-50-en_a_te

MOTOR TYPE THREE-PHASE	RATED POWER Kw HP		RATED VOLTAGE V	Cos φ	RATED CURRENT A	VOLTAGE DROP %	Cable cross section: 1 x ...mm ²								
							mm ²	50	70	95	120	150	185	240	300
							A max	192	246	298	346	399	456	538	621
Maximum length in metres															
G12W1500T405 HT	150	200	380	0,86	303	4	-	-	-	137	170	202	250	292	
			415	0,83	287		-	-	-	-	-	-	-		
G12W1850T405 HT	185	250	380	0,87	368		-	-	-	-	133	160	201	238	
			415	0,82	354		-	-	-	-	-	-	-		
G12W2200T405 HT	220	300	380	0,88	431		-	-	-	-	-	131	168	200	
			415	0,84	407		-	-	-	-	-	-	-		

Exposed cable laid at a temperature of 30°C, maximum conductor temperature of 90°C

G12w-ht-cavi-50-en_a_te

G12W - G12W HT, 50 Hz: SIZING OF ETHYLENE-PROPILENE (EPR) CABLES Y/Δ (STAR / DELTA) STARTING

MOTOR TYPE THREE-PHASE	RATED POWER Kw HP		RATED VOLTAGE V	Cos φ	RATED CURRENT A	VOLTAGE DROP %	Cable cross section: 1 x ...mm ²								
							mm ²	50	70	95	120	150	185	240	300
							A max*	333	426	516	599	691	790	932	1076
Maximum length in metres															
G12W1850T405	185	250	380	0,86	378	4	-	121	161	204	248	291	356	413	
			415	0,85	349		-	-	-	-	-	-	-		
G12W2200T405	220	300	380	0,87	438		-	-	134	171	209	248	305	356	
			415	0,84	413		-	-	-	-	-	-	-		
G12W2600T405	260	350	380	0,88	512		-	-	109	141	174	208	259	304	
			415	0,85	475		-	-	-	-	-	-	-		
G12W3000T405	300	400	380	0,82	621		-	-	-	-	139	166	205	239	
			415	0,73	640		-	-	-	-	-	-	-		

Exposed cable laid at a temperature of 30°C, maximum conductor temperature of 90°C

G12w-cavi-SD-50-en_a_te

*A max is the maximum rated current of the motor

MOTOR TYPE THREE-PHASE	RATED POWER Kw HP		RATED VOLTAGE V	Cos φ	RATED CURRENT A	VOLTAGE DROP %	Cable cross section: 1 x ...mm ²								
							mm ²	50	70	95	120	150	185	240	300
							A max*	333	426	516	599	691	790	932	1076
Maximum length in metres															
G12W1500T405 HT	150	200	380	0,86	303	4	-	109	160	209	262	315	368	448	518
			415	0,83	287		-	-	-	-	-	-	-		
G12W1850T405 HT	185	250	380	0,87	368		-	-	125	166	210	255	299	367	427
			415	0,82	354		-	-	-	-	-	-	-		
G12W2200T405 HT	220	300	380	0,88	431		-	-	-	136	174	213	252	312	365
			415	0,84	407		-	-	-	-	-	-	-		

Exposed cable laid at a temperature of 30°C, maximum conductor temperature of 90°C

G12w-ht-cavi-SD-50-en_a_te

*A max is the maximum rated current of the motor

SPLICE BETWEEN DROP CABLE AND MOTOR CABLE

MOTOR TYPE	POWER kW	TYPE OF SPLICE	FOUR-CORE DROP CABLE - SECTION (mm ²)												
			1,5	2,5	4	6	10	16	25	35	50	70	95	120	150
G4OS G4C	0,37 - 7,5	Resin-filled method	GR11	GR11	GR12	GR12	GR12	GR13	GR13	GR14	GR14	GR15	GR15	GR16	-
		Heat-shrink method	GT11	GT11	GT12	GT12	GT13	GT14	GT15	GT16	-	-	-	-	-
		Tape method	Self-vulcanizing tape + self-vulcanizing sealing putty and PVC tape (1)												
G6C G6W	4 - 37	Resin-filled method	-	-	GR12	GR12	GR12	GR13	GR13	GR14	GR14	GR15	GR15	GR16	-
		Heat-shrink method	-	-	GT12	GT12	GT13	GT14	GT15	GT16	-	-	-	-	-
		Tape method	Self-vulcanizing tape + self-vulcanizing sealing putty and PVC tape (1)												

MOTOR TYPE	POWER kW	TYPE OF SPLICE	THREE-CORE DROP CABLE - SECTION (mm ²)												
			1,5	2,5	4	6	10	16	25	35	50	70	95	120	150
G6C G6W	4 - 37	Resin-filled method	-	-	GR12	GR12	GR12	GR13	GR13	GR14	GR14	GR15	GR15	GR16	-
		Heat-shrink method	-	-	GT12	GT12	GT13	GT14	GT15	GT16	-	-	-	-	-
		Tape method	Self-vulcanizing tape + PVC tape												

MOTOR TYPE	POWER kW	TYPE OF SPLICE	SINGLE-CORE DROP CABLE - SECTION (mm ²)												
			1,5	2,5	4	6	10	16	25	35	50	70	95	120	150
G8W G10W G12W	30 - 300	Resin-filled method	-	-	-	GR12	GR12	GR17	GR17	GR17	GR18	GR18	GR18	GR19	GR19
		Heat-shrink method	-	-	-	-	-	-	-	-	-	-	-	-	-
		Tape method	Self-vulcanizing tape + PVC tape												

(1) Use self-vulcanizing sealing putty to fill in the gaps between the three-conductor cable and the ground cable in the area covered by the final layer of tape, to restore continuity to the protective sheath.

RESIN-FILLED SPLICES				HEAT-SHRINK SPLICES			
TYPE	L x D [mm]	TYPE	L x D [mm]	TYPE	L x D [mm]	TYPE	L x D [mm]
GR11	190 x 45	GR14	357 x 62	GT11	330	GT14	330
GR12	190 x 51	GR15	325 x 95	GT12	330	GT15	500
GR13	240 x 62	GR16	520 x 100	GT13	330	GT16	500

G-giunzioni-en_a_te

CALCULATING THE SPEED OF THE FLUID THAT FLOWS AROUND A SUBMERGED MOTOR AND SIZING OF THE COOLING SLEEVE

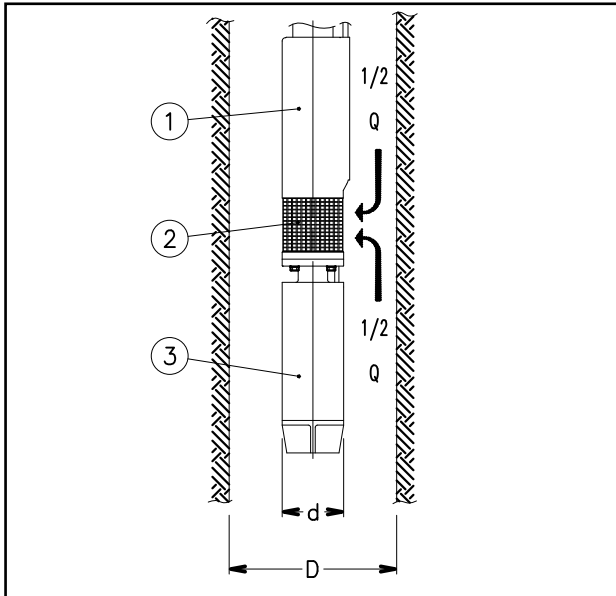

The following formula is used to verify whether the speed of the fluid that flows around the motor of a submersible pump is high enough to guarantee the proper cooling of the motor:

$$v = \frac{\frac{Q}{2}}{\pi \cdot \left(\frac{D^2}{4} - \frac{d^2}{4} \right)}$$

Where:

- Q** in [m³/s] is the operating flow rate of the electric pump; only half of this flow is taken into account, because the fluid which is sucked into the area of the filter (2), comes from the motor side (3) as well as from the pump side (1);
- D** in [m] is the diameter of the well;
- d** in [m] is the diameter of the motor (3);
- v** in [m/s] is the calculated speed of the fluid that flows around the motor.

Now, compare the speed thus calculated (v) with the minimum speed required for correct cooling of the motor (v_m): if $v \geq v_m$ it means that the motor is properly cooled, if $v < v_m$ will be necessary to mount a cooling sleeve (4).

Example:

An electric pump OZ630/12 (motor diameter $d = 0.144$ m) operates in an 8" well (well diameter $D = 0.203$ m) with flow rate $Q = 20$ m³/h = 0.0055 m³/s. Speed of fluid $v = (0.0055/2) / \{ \pi \cdot [(0.203)^2/4 - (0.144)^2/4] \} = 0.17$ m/s. The minimum speed required for proper motor cooling is $v_m = 0.20$ m/s. Because $v < v_m$, it will be necessary to mount a cooling sleeve.

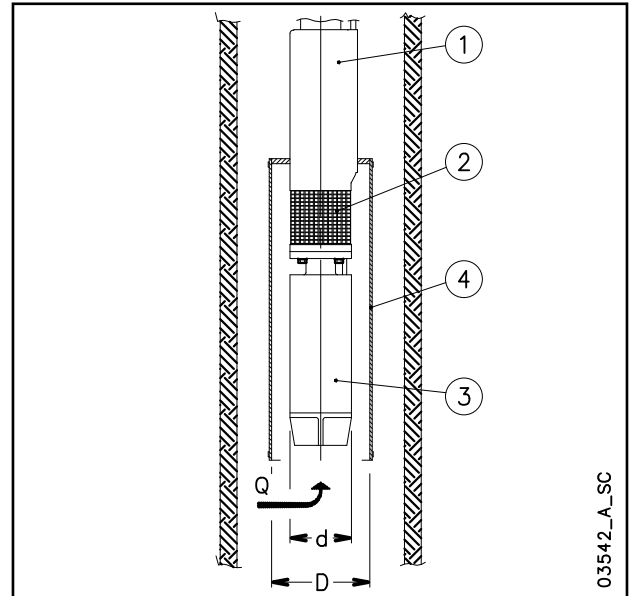

The following formula is used to determine the maximum diameter of a cooling sleeve to be mounted on a submersible motor:

$$D = \sqrt{4 \cdot \left(\frac{Q}{v \cdot \pi} + \frac{d^2}{4} \right)}$$

Where:

- Q** in [m³/s] is the operating flow rate of the electric pump; the entire flow is taken into account because the fluid comes from the motor side (3) only;
- D** in [m] corresponds to the diameter of the cooling sleeve (4);
- d** in [m] corresponds to the diameter of the motors(3);
- v_m** in [m/s] is the minimum speed of the fluid that flows around the motor.

If the electric pump operates at different flow rate, the minimum flow rate must be taken into account for calculating the diameter of the cooling sleeve.

Example:

A motor coupled to the electric pump OZ615/24 (motor diameter $d = 0.144$ m), which operates with flow rate $Q = 15$ m³/h = 0.0042 m³/s, requires a minimum speed of the fluid of $v_m = 0.20$ m/s. Cooling sleeve diameter $D = \{ 4 \cdot [(0.0042 / (0.2 \cdot \pi)) + (0.144)^2/4] \}^{0.5} = 0.217$ m.

03542_A_SC

ASYNCHRONOUS MOTOR STARTING SYSTEMS

Direct

Suitable for low-power motors.
The starting current (I_s) is much higher than the rated current (I_n).

$$\text{Starting current } I_s = I_n \times 4 \div 8$$

$$\text{Starting torque } T_s = T_n \times 2 \div 3$$

Indirect

• Star/Delta

The starting current (I_s) is three times less than the direct starting current.
Starting current $I_s = I_n \times 1.3 \div 2.7$
Starting torque $T_s = T_n \times 0.7 \div 1$
In the star to delta changeover phase (approx. 70 ms) the motor is not supplied and tends to reduce its rotation speed.
In the case of submersible electric pumps with power above 10 HP, the modest mass of the rotor causes a slowdown at changeover, so that the initial Star supply phase is rendered partially useless.
In such cases we recommend using impedance panels or an autotransformer.

• Impedances

The motor is started with a voltage which is lower than the rated one, and which is obtained by means of impedances.
The Lowara panels use impedances which cut down to 70% the starting voltage.
The switch to the rated voltage takes place without any interruptions of the power supply.

$$\text{Rated voltage } U_n = 400 \text{ V}$$

$$\text{Starting voltage } U_s = U_n \times 0,7 = 280 \text{ V}$$

Starting current

$$I_s = I_n \times 4 \div 8 \times \left(\frac{U_s}{U_n} \right) = I_n \times 3 \div 6$$

Starting torque

$$T_s = T_n \times 2 \div 3 \times \left(\frac{U_s}{U_n} \right)^2 = T_n \times 1 \div 1,5$$

Autotransformer

The pump is started with a voltage which is lower than the rated one.

The Lowara panels use an autotransformer with a voltage that is 70% the value of the line voltage.
The switch to the rated voltage occurs without any interruptions of the power supply.
Rated voltage $U_n = 400 \text{ V}$

Starting current

$$I_s = I_n \times 4 \div 8 \times \left(\frac{U_s}{U_n} \right) = I_n \times 3 \div 6$$

Starting torque

$$T_s = T_n \times 2 \div 3 \times \left(\frac{U_s}{U_n} \right)^2 = T_n \times 1 \div 1,5$$

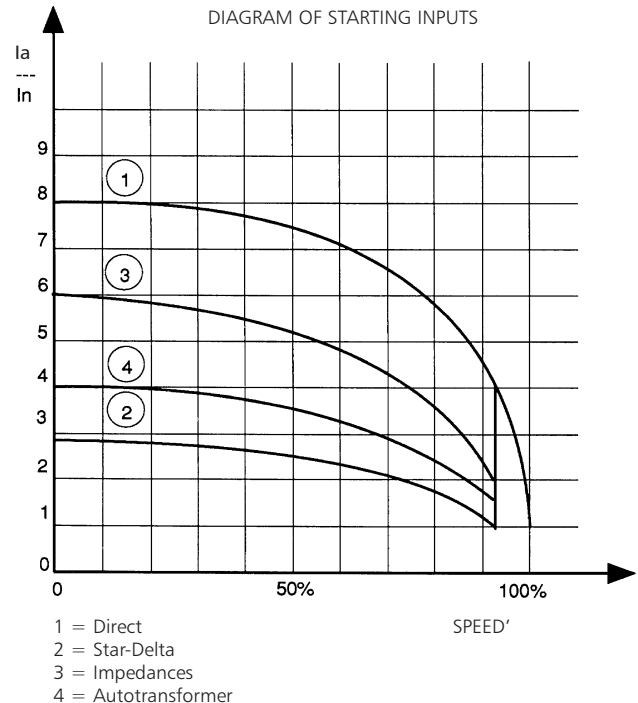

WATER REQUIREMENTS IN CIVIL USERS

Determination of the water requirement depends on the type of users and contemporaneity factor. The calculation may be subject to regulations, standards or customs that may vary from country to country. The calculation method shown below is an example based on practical experience, designed to provide a reference value and not a substitute for detailed analytical calculation.

Water requirements in condominiums.

The **consumption table** shows the maximum values for each delivery point, depending on the plumbing amenities.

MAXIMUM CONSUMPTION FOR EACH DELIVERY POINT

TYPE	CONSUMPTION (l/min)
Sink	9
Dishwasher	10
Washing machine	12
Shower	12
Bathtub	15
Washbasin	6
Bidet	6
Flush tank WC	6
Controlled flushing system WC	90

The **sum of the water consumption values** of each delivery point determines the maximum theoretical requirement, which must be reduced according to the **contemporaneity coefficient**, because in actual fact the delivery points are never used all together.

$$f = \frac{1}{\sqrt{(0,857 \times Nr \times Na)}} \quad \text{Coefficient for apartments with one bathroom and flush tank WC}$$

$$f = \frac{1}{\sqrt{(0,857 \times Nr \times Na)}} \quad \text{Coefficient for apartments with one bathroom and controlled flushing system WC}$$

$$f = \frac{1,03}{\sqrt{(0,545 \times Nr \times Na)}} \quad \text{Coefficient for apartments with two bathrooms and flush tank WC}$$

$$f = \frac{0,8}{\sqrt{(0,727 \times Nr \times Na)}} \quad \text{Coefficient for apartments with two bathrooms and controlled flushing system WC}$$

f= coefficient; Nr= number of delivery points; Na= number of apartments

The **table of water requirements in civil users** shows the maximum contemporaneity flow-rate values based on the **number of apartments** and the type of WC for apartments with one bathroom and two bathrooms. As regards apartments with one bathroom, 7 drawing points have been taken into consideration, while 11 points have been considered for apartments with two bathrooms. If the number of drawing points or apartments is different, use the formulas to **calculate** the requirement.

TABLE OF WATER REQUIREMENTS IN CIVIL USERS

NUMBER OF APARTMENTS	WITH FLUSH TANK WC		WITH CONTROLLED FLUSHING SYSTEM WC	
	1	2	1	2
	FLOW RATE (l/min)			
1	32	40	60	79
2	45	56	85	111
3	55	68	105	136
4	63	79	121	157
5	71	88	135	176
6	78	97	148	193
7	84	105	160	208
8	90	112	171	223
9	95	119	181	236
10	100	125	191	249
11	105	131	200	261
12	110	137	209	273
13	114	143	218	284
14	119	148	226	295
15	123	153	234	305
16	127	158	242	315
17	131	163	249	325
18	134	168	256	334
19	138	172	263	343
20	142	177	270	352
21	145	181	277	361
22	149	185	283	369
23	152	190	290	378
24	155	194	296	386
25	158	198	302	394
26	162	202	308	401
27	165	205	314	409
28	168	209	320	417
29	171	213	325	424
30	174	217	331	431
35	187	234	357	466
40	200	250	382	498
45	213	265	405	528
50	224	280	427	557
55	235	293	448	584
60	245	306	468	610
65	255	319	487	635
70	265	331	506	659
75	274	342	523	682
80	283	354	540	704
85	292	364	557	726
90	301	375	573	747
95	309	385	589	767
100	317	395	604	787
120	347	433	662	863
140	375	468	715	932
160	401	500	764	996
180	425	530	811	1056
200	448	559	854	1114

For seaside resorts, a flow rate increased by at least 20% must be considered.

G-at-fi_a_th

WATER REQUIREMENTS FOR COMMUNITY BUILDINGS

The requirements of buildings intended for specific uses, such as **offices, residential units, hotels, department stores, nursing homes** and so on, are different from those of condominiums, and both their global daily water consumption and the maximum contemporaneity flow rate are usually greater. The **diagram of water requirements for community buildings** shows the maximum contemporaneity flow rate of some types of communities, for guidance. These requirements must be determined case by case with the utmost accuracy, using analytical calculation methods, according to particular needs and local provisions.

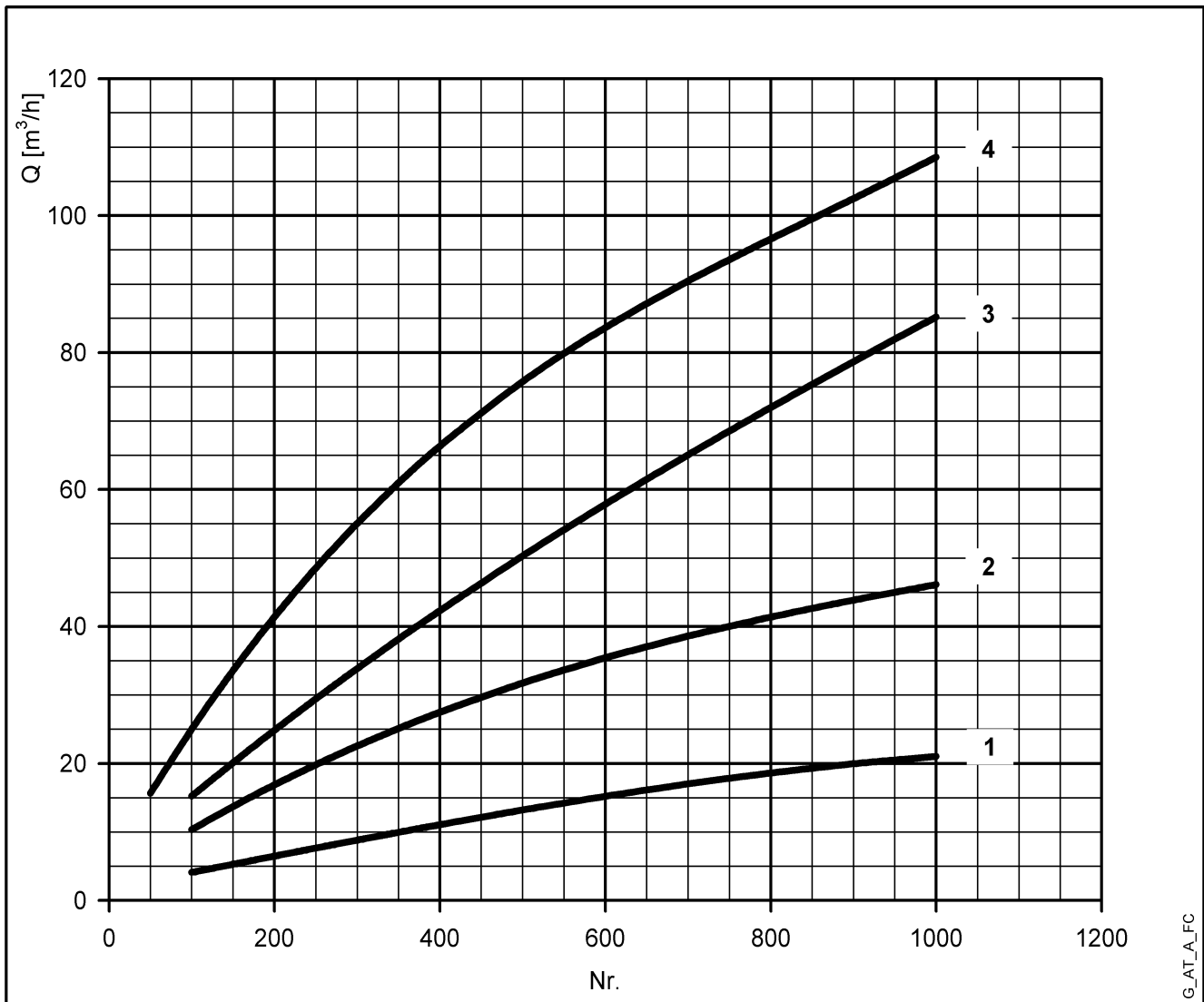

For seaside resorts, the flow rate must be increased by at least 20%.

- 1= Offices (N. of people)
- 2= Department stores (N. of people)
- 3= Nursing homes (N. of beds)
- 4= Hotels, residences (N. of beds)

NPSH

The minimum operating values that can be reached at the pump suction end are limited by the onset of cavitation.

Cavitation is the formation of vapour-filled cavities within liquids where the pressure is locally reduced to a critical value, or where the local pressure is equal to, or just below the vapour pressure of the liquid.

The vapour-filled cavities flow with the current and when they reach a higher pressure area the vapour contained in the cavities condenses. The cavities collide, generating pressure waves that are transmitted to the walls. These, being subjected to stress cycles, gradually become deformed and yield due to fatigue. This phenomenon, characterized by a metallic noise produced by the hammering on the pipe walls, is called incipient cavitation.

The damage caused by cavitation may be magnified by electrochemical corrosion and a local rise in temperature due to the plastic deformation of the walls. The materials that offer the highest resistance to heat and corrosion are alloy steels, especially austenitic steel. The conditions that trigger cavitation may be assessed by calculating the total net suction head, referred to in technical literature with the acronym NPSH (Net Positive Suction Head).

The NPSH represents the total energy (expressed in m.) of the liquid measured at suction under conditions of incipient cavitation, excluding the vapour pressure (expressed in m.) that the liquid has at the pump inlet.

To find the static height h_z at which to install the machine under safe conditions, the following formula must be verified:

$$h_p + h_z \geq (\text{NPSHr} + 0.5) + h_f + h_{pv} \text{ ①}$$

where:

h_p is the absolute pressure applied to the free liquid surface in the suction tank, expressed in m. of liquid; h_p is the quotient between the barometric pressure and the specific weight of the liquid.

h_z is the suction lift between the pump axis and the free liquid surface in the suction tank, expressed in m.; h_z is negative when the liquid level is lower than the pump axis.

h_f is the flow resistance in the suction line and its accessories, such as: fittings, foot valve, gate valve, elbows, etc.

h_{pv} is the vapour pressure of the liquid at the operating temperature, expressed in m. of liquid. h_{pv} is the quotient between the P_v vapour pressure and the liquid's specific weight.

0,5 is the safety factor.

The maximum possible suction head for installation depends on the value of the atmospheric pressure (i.e. the elevation above sea level at which the pump is installed) and the temperature of the liquid.

To help the user, with reference to water temperature (4° C) and to the elevation above sea level, the following tables show the drop in hydraulic pressure head in relation to the elevation above sea level, and the suction loss in relation to temperature.

Water temperature (°C)	20	40	60	80	90	110	120
Suction loss (m)	0,2	0,7	2,0	5,0	7,4	15,4	21,5

Elevation above sea level (m)	500	1000	1500	2000	2500	3000
Suction loss (m)	0,55	1,1	1,65	2,2	2,75	3,3

Friction loss is shown in the tables at pages 117-118 of this catalogue. To reduce it to a minimum, especially in cases of high suction head (over 4-5 m.) or within the operating limits with high flow rates, we recommend using a suction line having a larger diameter than that of the pump's suction port. It is always a good idea to position the pump as close as possible to the liquid to be pumped.

Make the following calculation:

Liquid: water at ~15°C $\gamma = 1 \text{ kg/dm}^3$

Flow rate required: 30 m³/h

Head for required delivery: 43 m.

Suction lift: 3,5 m.

The selection is an FHE 40-200/75 pump whose NPSH required value is, at 30 m³/h, di 2,5 m.

For water at 15 °C

$$h_p = P_a / \gamma = 10,33\text{m}, h_{pv} = P_v / \gamma = 0,174\text{m} (0,01701 \text{ bar})$$

The H_f flow resistance in the suction line with foot valves is ~ 1,2 m.

By substituting the parameters in formula ① with the numeric values above, we have:

$$10,33 + (-3,5) \geq (2,5 + 0,5) + 1,2 + 0,17$$

from which we have: 6,8 > 4,4

The relation is therefore verified.

TECHNICAL APPENDIX VAPOUR PRESSURE ps VAPOUR PRESSURE AND ρ DENSITY OF WATER TABLE

t °C	T K	ps bar	ρ kg/dm ³	t °C	T K	ps bar	ρ kg/dm ³	t °C	T K	ps bar	ρ kg/dm ³
0	273,15	0,00611	0,9998	55	328,15	0,15741	0,9857	120	393,15	1,9854	0,9429
1	274,15	0,00657	0,9999	56	329,15	0,16511	0,9852	122	395,15	2,1145	0,9412
2	275,15	0,00706	0,9999	57	330,15	0,17313	0,9846	124	397,15	2,2504	0,9396
3	276,15	0,00758	0,9999	58	331,15	0,18147	0,9842	126	399,15	2,3933	0,9379
4	277,15	0,00813	1,0000	59	332,15	0,19016	0,9837	128	401,15	2,5435	0,9362
5	278,15	0,00872	1,0000	60	333,15	0,1992	0,9832	130	403,15	2,7013	0,9346
6	279,15	0,00935	1,0000	61	334,15	0,2086	0,9826	132	405,15	2,867	0,9328
7	280,15	0,01001	0,9999	62	335,15	0,2184	0,9821	134	407,15	3,041	0,9311
8	281,15	0,01072	0,9999	63	336,15	0,2286	0,9816	136	409,15	3,223	0,9294
9	282,15	0,01147	0,9998	64	337,15	0,2391	0,9811	138	411,15	3,414	0,9276
10	283,15	0,01227	0,9997	65	338,15	0,2501	0,9805	140	413,15	3,614	0,9258
11	284,15	0,01312	0,9997	66	339,15	0,2615	0,9799	145	418,15	4,155	0,9214
12	285,15	0,01401	0,9996	67	340,15	0,2733	0,9793	155	428,15	5,433	0,9121
13	286,15	0,01497	0,9994	68	341,15	0,2856	0,9788	160	433,15	6,181	0,9073
14	287,15	0,01597	0,9993	69	342,15	0,2984	0,9782	165	438,15	7,008	0,9024
15	288,15	0,01704	0,9992	70	343,15	0,3116	0,9777	170	433,15	7,920	0,8973
16	289,15	0,01817	0,9990	71	344,15	0,3253	0,9770	175	448,15	8,924	0,8921
17	290,15	0,01936	0,9988	72	345,15	0,3396	0,9765	180	453,15	10,027	0,8869
18	291,15	0,02062	0,9987	73	346,15	0,3543	0,9760	185	458,15	11,233	0,8815
19	292,15	0,02196	0,9985	74	347,15	0,3696	0,9753	190	463,15	12,551	0,8760
20	293,15	0,02337	0,9983	75	348,15	0,3855	0,9748	195	468,15	13,987	0,8704
21	294,15	0,24850	0,9981	76	349,15	0,4019	0,9741	200	473,15	15,550	0,8647
22	295,15	0,02642	0,9978	77	350,15	0,4189	0,9735	205	478,15	17,243	0,8588
23	296,15	0,02808	0,9976	78	351,15	0,4365	0,9729	210	483,15	19,077	0,8528
24	297,15	0,02982	0,9974	79	352,15	0,4547	0,9723	215	488,15	21,060	0,8467
25	298,15	0,03166	0,9971	80	353,15	0,4736	0,9716	220	493,15	23,198	0,8403
26	299,15	0,03360	0,9968	81	354,15	0,4931	0,9710	225	498,15	25,501	0,8339
27	300,15	0,03564	0,9966	82	355,15	0,5133	0,9704	230	503,15	27,976	0,8273
28	301,15	0,03778	0,9963	83	356,15	0,5342	0,9697	235	508,15	30,632	0,8205
29	302,15	0,04004	0,9960	84	357,15	0,5557	0,9691	240	513,15	33,478	0,8136
30	303,15	0,04241	0,9957	85	358,15	0,5780	0,9684	245	518,15	36,523	0,8065
31	304,15	0,04491	0,9954	86	359,15	0,6011	0,9678	250	523,15	39,776	0,7992
32	305,15	0,04753	0,9951	87	360,15	0,6249	0,9671	255	528,15	43,246	0,7916
33	306,15	0,05029	0,9947	88	361,15	0,6495	0,9665	260	533,15	46,943	0,7839
34	307,15	0,05318	0,9944	89	362,15	0,6749	0,9658	265	538,15	50,877	0,7759
35	308,15	0,05622	0,9940	90	363,15	0,7011	0,9652	270	543,15	55,058	0,7678
36	309,15	0,05940	0,9937	91	364,15	0,7281	0,9644	275	548,15	59,496	0,7593
37	310,15	0,06274	0,9933	92	365,15	0,7561	0,9638	280	553,15	64,202	0,7505
38	311,15	0,06624	0,9930	93	366,15	0,7849	0,9630	285	558,15	69,186	0,7415
39	312,15	0,06991	0,9927	94	367,15	0,8146	0,9624	290	563,15	74,461	0,7321
40	313,15	0,07375	0,9923	95	368,15	0,8453	0,9616	295	568,15	80,037	0,7223
41	314,15	0,07777	0,9919	96	369,15	0,8769	0,9610	300	573,15	85,927	0,7122
42	315,15	0,08198	0,9915	97	370,15	0,9094	0,9602	305	578,15	92,144	0,7017
43	316,15	0,09639	0,9911	98	371,15	0,9430	0,9596	310	583,15	98,70	0,6906
44	317,15	0,09100	0,9907	99	372,15	0,9776	0,9586	315	588,15	105,61	0,6791
45	318,15	0,09582	0,9902	100	373,15	1,0133	0,9581	320	593,15	112,89	0,6669
46	319,15	0,10086	0,9898	102	375,15	1,0878	0,9567	325	598,15	120,56	0,6541
47	320,15	0,10612	0,9894	104	377,15	1,1668	0,9552	330	603,15	128,63	0,6404
48	321,15	0,11162	0,9889	106	379,15	1,2504	0,9537	340	613,15	146,05	0,6102
49	322,15	0,11736	0,9884	108	381,15	1,3390	0,9522	350	623,15	165,35	0,5743
50	323,15	0,12335	0,9880	110	383,15	1,4327	0,9507	360	633,15	186,75	0,5275
51	324,15	0,12961	0,9876	112	385,15	1,5316	0,9491	370	643,15	210,54	0,4518
52	325,15	0,13613	0,9871	114	387,15	1,6362	0,9476	374,15	647,30	221,20	0,3154
53	326,15	0,14293	0,9862	116	389,15	1,7465	0,9460				
54	327,15	0,15002	0,9862	118	391,15	1,8628	0,9445				

G-at_npsh_a_sc

TABLE OF FLOW RESISTANCE IN 100 m OF STRAIGHT CAST IRON PIPELINE (HAZEN-WILLIAMS FORMULA C=100)

FLOW RATE		NOMINAL DIAMETER in mm and INCHES																		
m ³ /h	l/min		15	20	25	32	40	50	65	80	100	125	150	175	200	250	300	350	400	
			1/2"	3/4"	1"	1 1/4"	1 1/2"	2	2 1/2"	3"	4"	5"	6"	7"	8"	10"	12"	14"	16"	
0,6	10	v	0,94	0,53	0,34	0,21	0,13													
		hr	16	3,94	1,33	0,40	0,13													
0,9	15	v	1,42	0,80	0,51	0,31	0,20													
		hr	33,9	8,35	2,82	0,85	0,29													
1,2	20	v	1,89	1,06	0,68	0,41	0,27	0,17												
		hr	57,7	14,21	4,79	1,44	0,49	0,16												
1,5	25	v	2,36	1,33	0,85	0,52	0,33	0,21												
		hr	87,2	21,5	7,24	2,18	0,73	0,25												
1,8	30	v	2,83	1,59	1,02	0,62	0,40	0,25												
		hr	122	30,1	10,1	3,05	1,03	0,35												
2,1	35	v	3,30	1,86	1,19	0,73	0,46	0,30												
		hr	162	40,0	13,5	4,06	1,37	0,46												
2,4	40	v		2,12	1,36	0,83	0,53	0,34	0,20											
		hr		51,2	17,3	5,19	1,75	0,59	0,16											
3	50	v		2,65	1,70	1,04	0,66	0,42	0,25											
		hr		77,4	26,1	7,85	2,65	0,89	0,25											
3,6	60	v		3,18	2,04	1,24	0,80	0,51	0,30											
		hr		108	36,6	11,0	3,71	1,25	0,35											
4,2	70	v		3,72	2,38	1,45	0,93	0,59	0,35											
		hr		144	48,7	14,6	4,93	1,66	0,46											
4,8	80	v		4,25	2,72	1,66	1,06	0,68	0,40											
		hr		185	62,3	18,7	6,32	2,13	0,59											
5,4	90	v			3,06	1,87	1,19	0,76	0,45	0,30										
		hr			77,5	23,3	7,85	2,65	0,74	0,27										
6	100	v			3,40	2,07	1,33	0,85	0,50	0,33										
		hr			94,1	28,3	9,54	3,22	0,90	0,33										
7,5	125	v			4,25	2,59	1,66	1,06	0,63	0,41										
		hr			142	42,8	14,4	4,86	1,36	0,49										
9	150	v			3,11	1,99	1,27	0,75	0,50	0,32										
		hr			59,9	20,2	6,82	1,90	0,69	0,23										
10,5	175	v			3,63	2,32	1,49	0,88	0,58	0,37										
		hr			79,7	26,9	9,07	2,53	0,92	0,31										
12	200	v			4,15	2,65	1,70	1,01	0,66	0,42										
		hr			102	34,4	11,6	3,23	1,18	0,40										
15	250	v			5,18	3,32	2,12	1,26	0,83	0,53	0,34									
		hr			154	52,0	17,5	4,89	1,78	0,60	0,20									
18	300	v			3,98	2,55	1,51	1,00	0,64	0,41										
		hr			72,8	24,6	6,85	2,49	0,84	0,28										
24	400	v				5,31	3,40	2,01	1,33	0,85	0,54	0,38								
		hr				124	41,8	11,66	4,24	1,43	0,48	0,20								
30	500	v				6,63	4,25	2,51	1,66	1,06	0,68	0,47								
		hr				187	63,2	17,6	6,41	2,16	0,73	0,30								
36	600	v				5,10	3,02	1,99	1,27	0,82	0,57	0,42								
		hr				88,6	24,7	8,98	3,03	1,02	0,42	0,20								
42	700	v				5,94	3,52	2,32	1,49	0,95	0,66	0,49								
		hr				118	32,8	11,9	4,03	1,36	0,56	0,26								
48	800	v				6,79	4,02	2,65	1,70	1,09	0,75	0,55								
		hr				151	42,0	15,3	5,16	1,74	0,72	0,34								
54	900	v				7,64	4,52	2,99	1,91	1,22	0,85	0,62								
		hr				188	52,3	19,0	6,41	2,16	0,89	0,42								
60	1000	v				5,03	3,32	2,12	1,36	0,94	0,69	0,53								
		hr				63,5	23,1	7,79	2,63	1,08	0,51	0,27								
75	1250	v				6,28	4,15	2,65	1,70	1,18	0,87	0,66								
		hr				96,0	34,9	11,8	3,97	1,63	0,77	0,40								
90	1500	v				7,54	4,98	3,18	2,04	1,42	1,04	0,80								
		hr				134	48,9	16,5	5,57	2,29	1,08	0,56								
105	1750	v				8,79	5,81	3,72	2,38	1,65	1,21	0,93								
		hr				179	65,1	21,9	7,40	3,05	1,44	0,75								
120	2000	v				6,63	4,25	2,72	1,89	1,39	1,06	0,68								
		hr				83,3	28,1	9,48	3,90	1,84	0,96	0,32								
150	2500	v				8,29	5,31	3,40	2,36	1,73	1,33	0,85								
		hr				126	42,5	14,3	5,89	2,78	1,45	0,49								
180	3000	v				6,37	4,08	2,83	2,08	1,59	1,02	0,71								
		hr				59,5	20,1	8,26	3,90	2,03	0,69	0,28								
210	3500	v				7,43	4,76	3,30	2,43	1,86	1,19	0,83								
		hr				79,1	26,7	11,0	5,18	2,71	0,91	0,38								
240	4000	v				8,49	5,44	3,77	2,77	2,12	1,36	0,94								
		hr				101	34,2	14,1	6,64	3,46	1,17	0,48								
300	5000	v				6,79	4,72	3,47	2,65	1,70	1,18	0,87								
		hr				51,6	21,2	10,0	5,23	1,77	0,73	0,34								
360	6000	v				8,15	5,66	4,16	3,18	2,04	1,42	1,04								
		hr				72,3	29,8	14,1	7,33	2,47	1,02	0,40								
420	7000	v				6,61	4,85	3,72	2,38	1,65	1,21	0,93								
		hr				39,6	18,7	9,75	3,29	1,35	0,64	0,26								
480	8000	v				7,55	5,55	4,25	2,72	1,89	1,39	1,02								
		hr				50,7	23,9	12,49	4,21	1,73	0,82	0,31								
540	9000	v				8,49	6,24	4,78	3,06	2,12	1,56	1,19								
		hr				63,0	29,8	15,5	5,24	2,16	1,02	0,53								
600	10000	v				6,93	5,31	3,40	2,36	1,73	1,33	0,85								

FLOW RESISTANCE

TABLE OF FLOW RESISTANCE IN BENDS, VALVES AND GATES

The flow resistance is calculated using the equivalent pipeline length method according to the table below:

ACCESSORY TYPE	DN											
	25	32	40	50	65	80	100	125	150	200	250	300
	Equivalent pipeline length (m)											
45° bend	0,2	0,2	0,4	0,4	0,6	0,6	0,9	1,1	1,5	1,9	2,4	2,8
90° bend	0,4	0,6	0,9	1,1	1,3	1,5	2,1	2,6	3,0	3,9	4,7	5,8
90° smooth bend	0,4	0,4	0,4	0,6	0,9	1,1	1,3	1,7	1,9	2,8	3,4	3,9
Union tee or cross	1,1	1,3	1,7	2,1	2,6	3,2	4,3	5,3	6,4	7,5	10,7	12,8
Gate	-	-	-	0,2	0,2	0,2	0,4	0,4	0,6	0,9	1,1	1,3
Non return valve	1,1	1,5	1,9	2,4	3,0	3,4	4,7	5,9	7,4	9,6	11,8	13,9

G-a-pcv_a_th

The table is valid for the Hazen Williams coefficient $C = 100$ (cast iron pipework):

-For steel pipework, multiply the values by 1.41.

-For stainless steel, copper and coated cast iron pipework, multiply the values by 1.85.

When the **equivalent pipeline length** has been determined, the flow resistance is obtained from the table of flow resistance.

The values given are guideline values which are bound to vary slightly according to the model, especially for gate valves and non-return valves, for which it is a good idea to check the values supplied by the manufacturers.

VOLUMETRIC CAPACITY

Litres per minute l/min	Cubic metres per hour m ³ /h	Cubic feet per hour ft ³ /h	Cubic feet per minute ft ³ /min	Imperial gallon per minute Imp. gal/min	U.S. gallon per minute US gal/min
1,000	0,0600	2,1189	0,0353	0,2200	0,2642
16,6667	1,0000	35,3147	0,5886	3,6662	4,4029
0,4719	0,0283	1,0000	0,0167	0,1038	0,1247
28,3168	1,6990	60,0000	1,0000	6,2288	7,4805
4,5461	0,2728	9,6326	0,1605	1,0000	1,2009
3,7854	0,2271	8,0208	0,1337	0,8327	1,0000

PRESSURE AND HEAD

Newton per square metre N/m ²	kilo Pascal kPa	bar bar	Pound force per square inch psi	Metre of water m H ₂ O	Millimetre of mercury mm Hg
1,0000	0,0010	1×10^{-5}	$1,45 \times 10^{-4}$	$1,02 \times 10^{-4}$	0,0075
1 000,0000	1,0000	0,0100	0,1450	0,1020	7,5006
1×10^5	100,0000	1,0000	14,5038	10,1972	750,0638
6 894,7570	6,8948	0,0689	1,0000	0,7031	51,7151
9 806,6500	9,8067	0,0981	1,4223	1,0000	73,5561
133,3220	0,1333	0,0013	0,0193	0,0136	1,0000

LENGTH

Millimetre mm	Centimetre cm	Metre m	Inch in	Foot ft	Yard yd
1,0000	0,1000	0,0010	0,0394	0,0033	0,0011
10,0000	1,0000	0,0100	0,3937	0,0328	0,0109
1 000,0000	100,0000	1,0000	39,3701	3,2808	1,0936
25,4000	2,5400	0,0254	1,0000	0,0833	0,0278
304,8000	30,4800	0,3048	12,0000	1,0000	0,3333
914,4000	91,4400	0,9144	36,0000	3,0000	1,0000

VOLUME

Cubic metre m ³	Litre L	Millilitre ml	Imperial gallon imp. gal.	U.S. gallon US gal.	Cubic foot ft ³
1,0000	1 000,0000	1×10^6	219,9694	264,1720	35,3147
0,0010	1,0000	1 000,0000	0,2200	0,2642	0,0353
1×10^{-6}	0,0010	1,0000	$2,2 \times 10^{-4}$	$2,642 \times 10^{-4}$	$3,53 \times 10^{-5}$
0,0045	4,5461	4 546,0870	1,0000	1,2009	0,1605
0,0038	3,7854	3 785,4120	0,8327	1,0000	0,1337
0,0283	28,3168	28 316,8466	6,2288	7,4805	1,0000

TEMPERATURE

Water	Kelvin K	Celsius °C	Fahrenheit °F	$^{\circ}\text{F} = ^{\circ}\text{C} \times \frac{9}{5} + 32$ $^{\circ}\text{C} = (^{\circ}\text{F} - 32) \times \frac{5}{9}$
icing	273,1500	0,0000	32,0000	
boiling	373,1500	100,0000	212,0000	

G-at_pp-en_b_sc

FURTHER PRODUCT SELECTION AND DOCUMENTATION

Xylect™

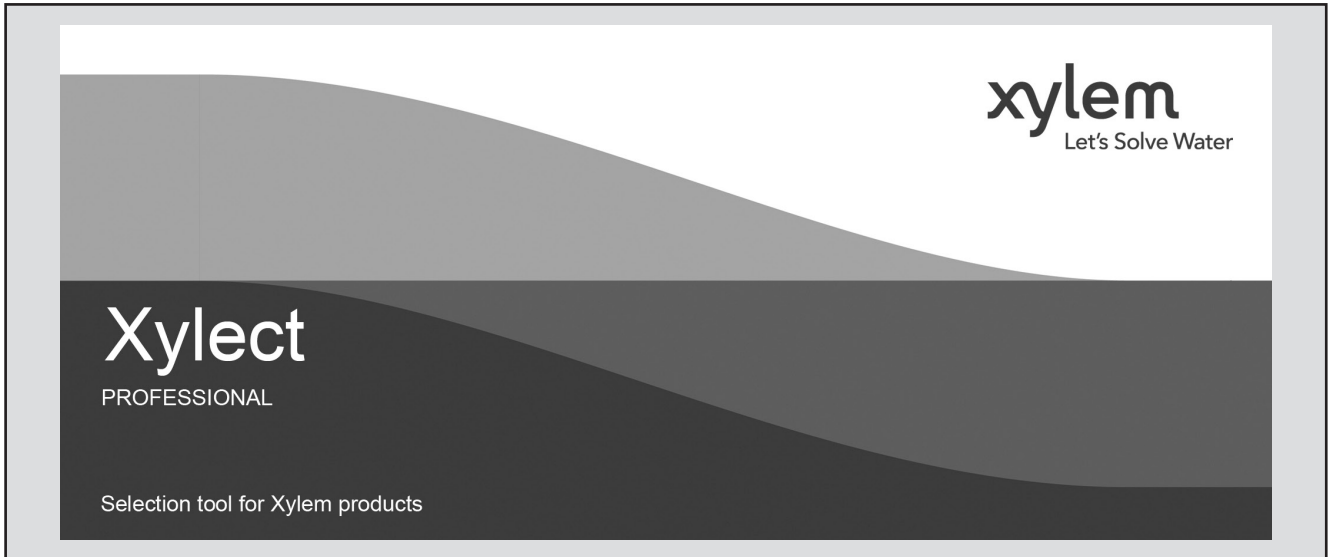

Xylect™ is pump solution selection software with an extensive online database of product information across the entire Lowara, and Vogel range of pumps and related products, with multiple search options and helpful project management facilities. The system holds up-to-date product information on thousands of products and accessories.

The possibility to search by applications and the detailed information output given makes it easy to make the optimal selection without having detailed knowledge about the Lowara and Vogel products.

The search can be made by:

- Application
- Product type
- Duty point

Xylect™ gives a detailed output:

- List with search results
- Performance curves (flow, head, power, efficiency, NPSH)
- Motor data
- Dimensional drawings
- Options
- Data sheet printouts
- Document downloads incl dxf files

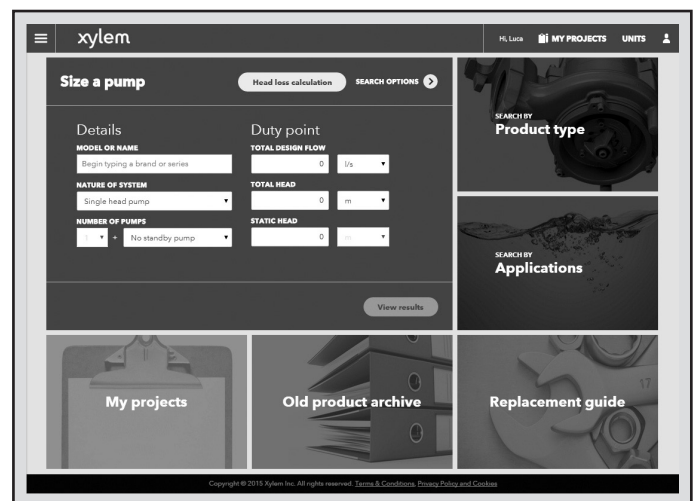

The search by application guides users not familiar with the product range to the right choice.

FURTHER PRODUCT SELECTION AND DOCUMENTATION

Xylect™



The detailed output makes it easy to select the optimal pump from the given alternatives.

The best way to work with Xylect is to create a personal account. This makes it possible to:

- Set own standard units
- Create and save projects
- Share projects with other Xylect users

Every registered user has a proper space, where all projects are saved.

For more information about Xylect please contact our sales network or visit www.xylect.com.

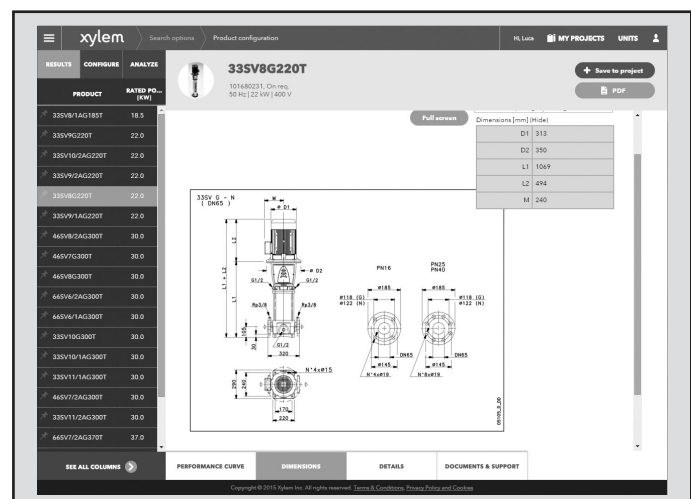

Dimensional drawings appear on the screen and can be downloaded in dxf format.

Xylem |'zīləm|



- 1) The tissue in plants that brings water upward from the roots;
- 2) a leading global water technology company.

We're a global team unified in a common purpose: creating advanced technology solutions to the world's water challenges. Developing new technologies that will improve the way water is used, conserved, and re-used in the future is central to our work. Our products and services move, treat, analyze, monitor and return water to the environment, in public utility, industrial, residential and commercial building services, and agricultural settings. With its October 2016 acquisition of Sensus, Xylem added smart metering, network technologies and advanced data analytics for water, gas and electric utilities to its portfolio of solutions. In more than 150 countries, we have strong, long-standing relationships with customers who know us for our powerful combination of leading product brands and applications expertise with a strong focus on developing comprehensive, sustainable solutions.

For more information on how Xylem can help you, go to www.xylem.com.



Sales office:

**Xylem Water Solutions
Middle East Region FZCO**

Plot S20120, Jebel Ali Free Zone South

P.O. Box 262678, Dubai

United Arab Emirates

Phone: +971 4 806 1103

Fax: +971 4 880 6045

Email: info.uae@xyleminc.com

middleeast.xylemappliedwater.com/gwt

For information and
technical support:

Xylem Service Italia Srl

Via Dottor Vittorio Lombardi 14

36075 - Montecchio Maggiore (VI)

Italy

Tel. (+39) 0444 707111

Fax (+39) 0444 491043

We reserve the right to make modification without prior notice.

Xylem is a trademark of Xylem Inc. or one of its subsidiaries. Goulds is a registered trademark of Goulds Pumps, Inc. and is used under license.

© 2017 Xylem, Inc.