

Manual

EN 7.1 Version 2003



Liquid Sampler 780

SAMPLER IN ROBUST DESIGN

mjk

a xylem brand

Your notes:

Table of Contents

General, Liquid Sampler 780	4
Function	4
Specifications	5
Mechanical mounting.....	6
Terminals	7
Examples.....	7
Settings	9
Operation	9
Start-up.....	10
Sample cycle	10
Setting of sequence times	11
External sequence	12
Miscellaneous.....	14
Maintenance.....	14
Spare parts	14
Mechanical dimensions	14

General, Liquid Sampler 780

Sampler 780 is designed for the collection of water samples from lakes, streams, treatment plants and pumping stations. The sampler can be used both in fixed installation and as a portable unit.

Sampler MJK 780 comes in fully welded stainless steel housing. The liquid-carrying parts are mounted in the front of the cabinet, while the pump, valves and electrical units are mounted in the bottom of the cabinet. The simple structure, the position of the test tube on the outside of the cabinet and the modular construction ensure simple and fast maintenance.

Function

MJK Liquid Sampler 780 is operated from the front panel or can be controlled via external signals from flowmeter, timer, or MJK Integrator 783. The MJK Liquid Sampler 780 can be connected directly to MJK Flowmeter 713 for flow proportional sampling.

MJK Liquid Sampler 780 uses pressure and vacuum for sampling. When the sampler receives a start signal from either the control panel or an external signal, the sample tube is pressurized to clear residue from the previous sample. The vacuum remains on until the sample glass is full. Then the glass is again pressurized to clear the surplus liquid from leaving the required sample (20 ml to 500 ml) in the glass.

When the required level is reached, the outlet valve opens and the sample runs into the collecting container.

MJK Liquid Sampler 780 has a built-in alarm system. If the sample tube is blocked during the filling of the sample glass, the alarm operation re-pressurizes the sampler to clear the obstruction. The cycle then starts again. If the sample glass is not filled at the second try within a preset time, the sampler will not be blocked.

The control system of the sampler is in a sturdy design and is unaffected by electrical noise. The sampler can be operated manually or controlled from a flowmeter or timer.

However if another cycle is desired, all cycle functions are located on a terminal block, so the control of the internal functions and monitoring can be taken over via a PLC or pc

Specifications

Sampling	
Cycle time:	App. 2 min (adjustable to 1 - 10 min)
Amount:	20 ml to 500 ml
Suction height:	0,75 bar abs
Pressure:	Max. 1 bar (when flushing the sample hose)
Sample temp.:	Max. +60° C
Environment:	-20 - +60° C
Suction tube::	PVC, inner dia. 9,0 mm x 2 m
Outlet tube:	Silicone, inner dia. 9,5 mm x 1 m
Mechanical data	
Housing:	Stainless steel
Enclosure:	IP 55
Weight:	5 Kg
Dimensions:	165 mm x 410 mm x 235 mm (w x h x d)
Electrical data	
Supply:	115/230V AC and 12V DC
Consumption	During sampling: 30 W
Consumption	At Stand by : 2 W

Mechanical mounting

The sampler should be mounted on a wall or bracket. On the back of the cabinet there is 2 'keyhole' slots at the top and a slot at the bottom for screws. Note, that 230 mm free space is required at the left hand side of the cabinet in order to be able to open the upper part of the cabinet.

The sample tube is immersed in the channel or the basin where the sample will be taken from. The outlet tube runs to the sample container, where the samples are stored until analysed. The tubes may be extended as required.

Please observe the following when mounting the sampler:

- The sampler must be mounted vertically so the inlet and outlet can have the most optimum position. Vertical mounting is required for utilising the measuring scale on the sample glass.
- The maximum vacuum capacity of the sampler is 8m WG (0,8 bar) and is used to lift the sample from an lower liquid surface, and to overcome pressure loss in the sample tube.
- The sampler must be mounted so the sample container can be placed underneath. Under particular circumstances it can be placed elsewhere, since the measured sample is forced out of the sample measuring chamber.
- During the summer months we recommend to avoid exposing the sample container to the heat of the sun.
- During the winter it will be necessary to protect the sampler from frost. The sampler is able to function down to -20° C, since the sampler is drained after every sample; there is only a minor risk for frost damages. On the other hand, the sampler must be protected, warmed and insulated when it is placed outdoors. Consideration as to air temperature, temperature and size of every sample as well as how long the samples have to be in the sample container, must be taken.

The sample tube must be straight without kinks when the vacuum cycle begins. (See illustration below).

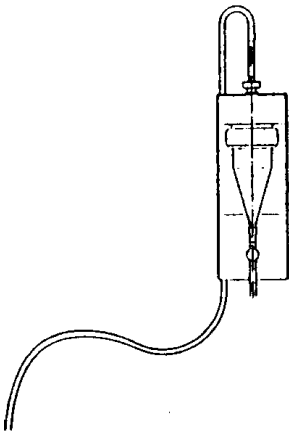

Sample tube, wrong!

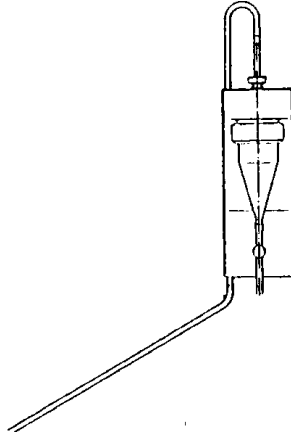

Sample tube, correct!

Terminals

The terminals for the electrical connection is found underneath the lid behind the sample glass. The sampler cabinet is opened with the enclosed cabinet key. Connect the sampler in accordance with the diagram.

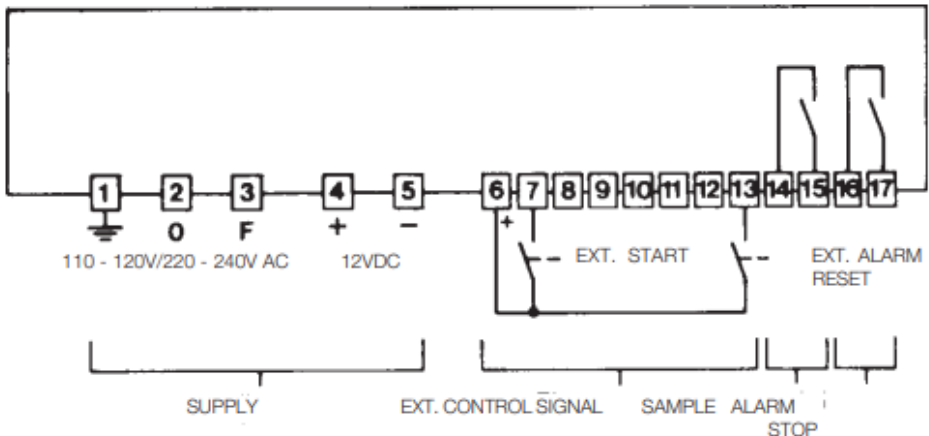

Examples

Flow proportional liquid sampling together with MJK Flow Converter 713.

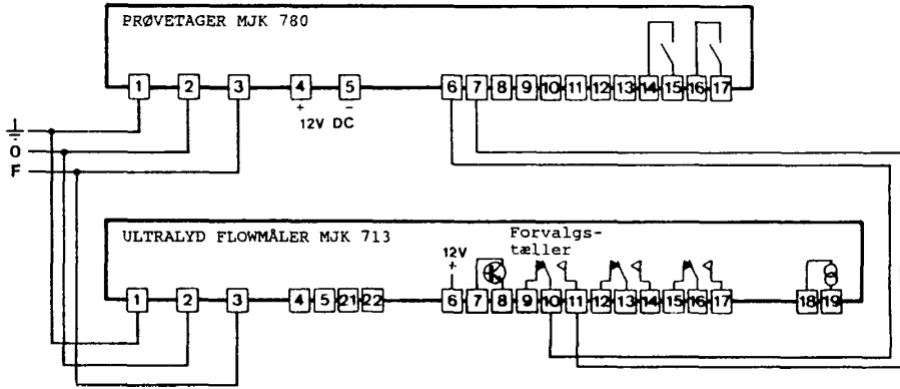

Settings

Operation

The sampler is operated on the control panel. The symbols have the following meaning and function:



Start/stop of the sampler.

The function is an electrical memory function, so the chosen position (start or stop) is maintained also after a power failure. The sampler will continue taking samples or stop according to the previous position. The green LED indicates that the sampler is on and ready (stand by) when a start signal occurs.



Manuel sampling.

By depressing the start key, a sample cycle is started. This function is always active and can be used alone or together with an external control signal. The green LED indicates that the sampler is in operation.



Alarm (reset).

The **ALARM** key resets the sample cycle. When there is an alarm, the light diode flashes (yellow), as described in [Setting of sequence times](#) (see page 11). It continues to flash until the key is activated to reset the alarm. If the key is pressed, regardless of where the sampler is in the cycle, sampling stops, the cycle resets and the sampler is ready to start.



Pressure indicator.

This LED (green) indicates that there is vacuum in the sample glass in order to:

- purge out the previous sample from the sample tube
- purge out excess liquid during adjustment of the sample volume
- flush the set sample volume into the sample can.

Vacuum		xxxxxxx		
Level detection		x		
Outlet valve open			xxxxxxxxxx	
Alarm		T 4		

As shown in [Start-up \(see page 10\)](#) and in this diagram, the compressor starts when the sampler is started. When starting, the valves are switched on to put pressure on the sample glass to remove any previous sample. The purge time is determined by the timer T 1 (purge). When timer T 1 has elapsed, the valves switch to create a vacuum. The sample glass and the water will be pulled into the sample glass, until the level electrodes are activated. When the level electrodes have been activated, the valves are switched over again to put pressure on the sample glass. Excess sample will be blown back in the sample tube. Pressure continues until the time, determined by the timer T 2 (excess), has elapsed. The outlet valve opens under pressure and the sample is dropped into the sample container. The outlet valve remains open for timer T 3 (outlet).

The final step is an additional drain of the tube to make sure it is empty before re-sampling. This drop is controlled by the timer T 1 (purge). It is possible to switch off the last purge by cutting off the connection **PURGE 2**.

The sequence contains an alarm, which activates if the sample does not contact the electrodes by a preset timer T 4 (alarm). This alarm protects the sampler from continuous cycles caused by blockage. However, since the compressor creates a 10m V pressure, it is not very likely that blockage will occur. If the sampler does not succeed to activate the level electrodes the second time before the timer T 4 has run out, the sampler will stop and prevent further starts. To indicate the alarm, the yellow alarm flashes and the alarm relay is activated. To make the sampler start again, the alarm state has to be reset by activating the **ALARM** key.

Setting of sequence times

The sequence time is factory adjusted to a total sample time of approx. 2 minutes. The 4 timers have the following time ranges:

Timer	(function)	Range	Factory settings
Purge	T1:	30-150 sec	30 sec
Excess	T2:	30-150 sec	30 sec
Outlet	T3:	30-150 sec	30 sec
Alarm	T4:	30-150 sec	60 sec

The sequence times are adjusted with the potentiometers on the back of the control unit. To adjust the time, the control unit must be removed. Switch off the sampler (**ON/OFF** key) and unscrew the 4 screws, which hold the front panel to the control panel. The control unit is integral with the front panel. When the control unit has been removed the sampler can be started again and the adjustment made.

There are no dangerous voltages present at the control unit, so it can be touched during operation. When the desired adjustment has been made, depress **ON/OFF** key to avoid short circuit during mounting, and the control unit attachment.

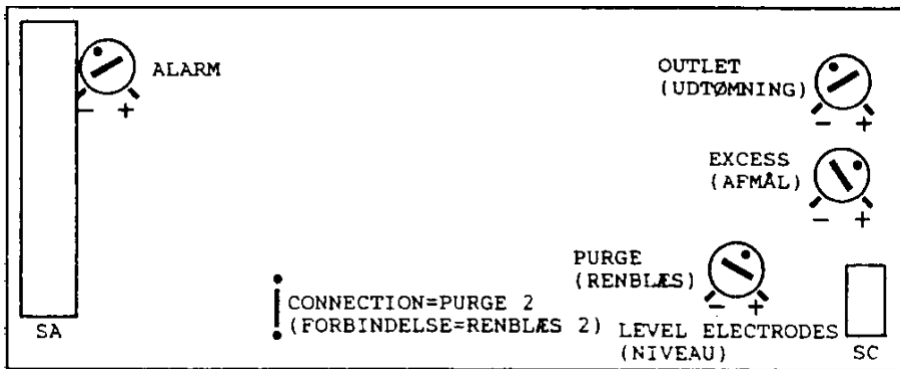

External sequence

The sampler can be controlled externally, e.g. from a PLC. When an external control is connected, it works in parallel with the internal control, so that it is possible to select a manual sample controlled by the internal system of the sampler, at the same time as the external control.

The inputs are semi-conductor inputs as indicated at the diagram.

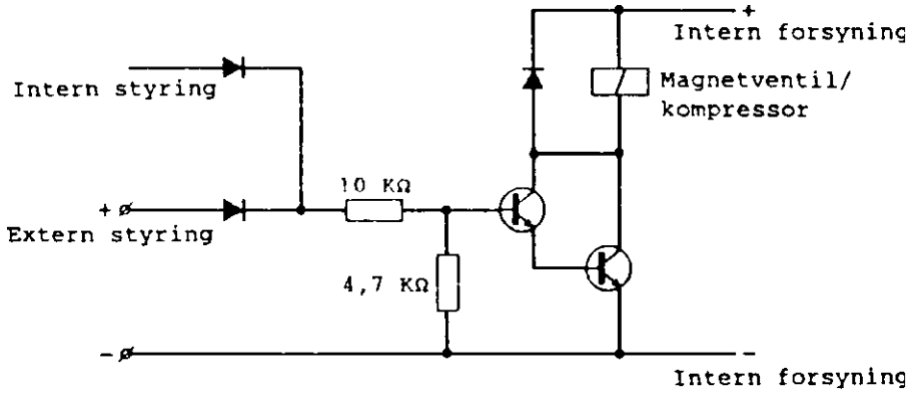

The input signal should be not activated <0,5 V DC. Activated 5-24 V DC.

Miscellaneous

Maintenance

The sampler must be kept clean of dirt on the following points:

- The sampler glass must be kept clean on the inside
- The level electrodes in the top of the sample glass must be cleaned
- The sample tube and the outlet tube must be cleaned

Spare parts

Item no.	Description
Complete units	
803510	Control unit complete with front panel
803515	Power supply unit 115/230V AC and 12V DC
813510	Valve/pumping unit
Other parts	
595120	Suction hose, PVC, dia. 9,0mm. Specify length.
595121	Discharge hose, Silicone, dia. 9,5mm, Specify length.
595110	Sample glass
570025	O ring for sample glass, silicone, dia. 75mm x 8mm
570027	O ring for sample glass, silicone, dia. 75mm x 8mm

Mechanical dimensions

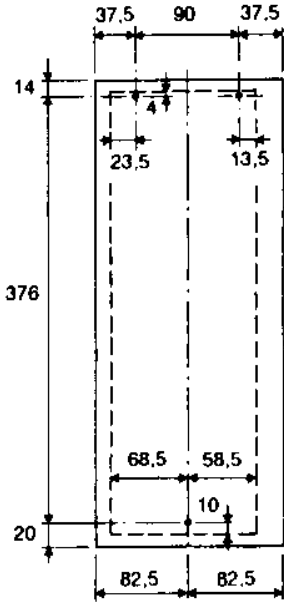

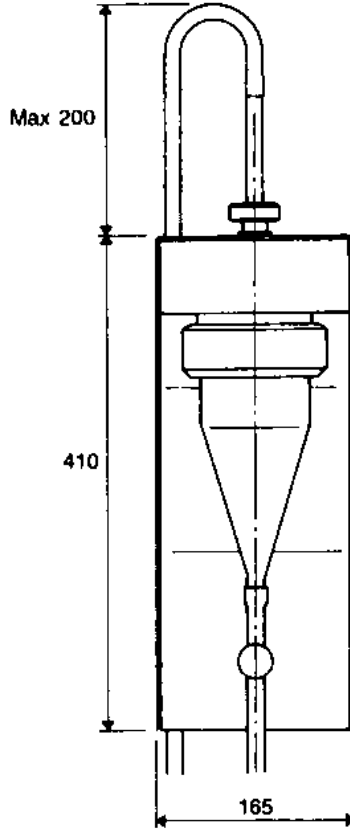
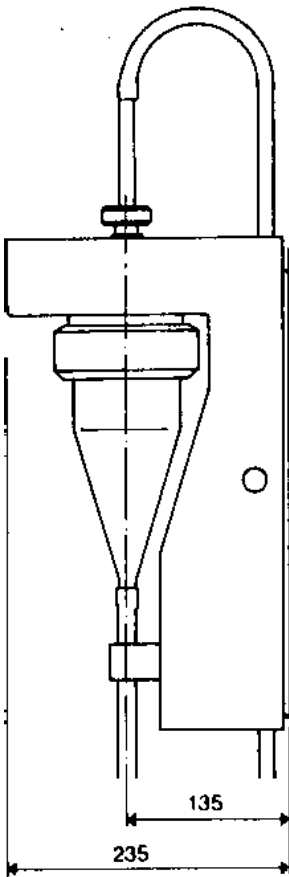

This page has been intentionally left blank

Xylem | 'zīləm|

- 1) The tissue in plants that brings water upward from the roots;
- 2) a leading global water technology company.

We're 12,700 people unified in a common purpose:

creating innovative solutions to meet our world's water needs. Developing new technologies that will improve the way water is used, conserved, and re-used in the future is central to our work.

We move, treat, analyze, and return water to the environment, and we help people use water efficiently, in their homes, buildings, factories and farms. In more than 150 countries, we have strong, long-standing relationships with customers who know us for our powerful combination of leading product brands and applications expertise, backed by a legacy of innovation.

For more information on how Xylem can help you, go to www.xyleminc.com



MJK Automation ApS
Blokken 9
DK-3460 Birkerød
Danmark
Tlf +45 45 56 06 56
www.mjk.com



Connect, Mμ Connect, Chatter, MagFlux, Oxix, pHix compact, Shuttle and SuSix are registered trademarks of MJK Automation ApS.

© 2019 Xylem, Inc