

MJK 713 Open Channel Flowmeter



Declaration of Conformity

Konformitetserklæring

Vi, MJK Automation A/S,
DK-3460 Birkerød, påtager os
det fulde ansvar for at produktet

Declaration of Conformity

We, MJK Automation A/S,
DK-3460 Birkerød, declare
under our sole responsibility
that the product

Konformitätserklärung

Wir, MJK Automation A/S,
DK-3460 Birkerød, erklären in
alleiniger Verantwortung,
dass das Produkt

MJK Expert Series 1400 / 3400 Pressure Level Transmitter

som denne erklæring angår,
er i overensstemmelse med
følgende standard(er) eller andre
normdokument(er).

EN60079.0:2006, EN60079.11:2007
EN61000-6-1:2007
EN61000-6-3:2007

efter bestemmelserne i
direktiv

2004/108/EC

Declaration de conformité

Nous, MJK Automation A/S,
DK-3460 Birkerød, déclarons
sous notre seule responsabilité
que le produit

to which this declaration relates
is in conformity with the following
standard(s) or other normative
document(s).

EN60079.0:2006, EN60079.11:2007
EN61000-6-1:2007
EN61000-6-3:2007

following the provisions of
Directive

2004/108/EC

Dichiarazione di conformità

Noi, MJK Automation A/S,
DK-3460 Birkerød, dichiariamo
sotto la nostra esclusiva respon-
sabilità che l'apparecchio

auf das sich diese Erklärung
bezieht mit der/den folgenden
Norme(en) oder normativen
Dokument(en) übereinstimmt.

EN60079.0:2006, EN60079.11:2007
EN61000-6-1:2007
EN61000-6-3:2007

Gemäss den Bestimmungen der
Richtlinie

2004/108/EC

Declaración de Conformidad

Nosotros, MJK Automation A/S,
DK-3460 Birkerød, declaramos
bajo nuestra única responsabili-
dad que el producto

MJK Expert Series 1400 / 3400 Pressure Level Transmitter

auquel se réfère cette déclara-
tion est conforme à la (aux)
norme(s) ou autre(s) document(s)
normatif(s)

EN60079.0:2006, EN60079.11:2007
EN61000-6-1:2007
EN61000-6-3:2007

conformément aux dispositions
de Directive

2004/108/EC

al quale questa dichiarazione si
riferisce, è conforme alla seg-
uente normativa(e) standard o ad
altri documenti di normativa(e)

EN60079.0:2006, EN60079.11:2007
EN61000-6-1:2007
EN61000-6-3:2007

conformemente alla disposizioni
della Direziona

2004/108/EC

06.07.2011

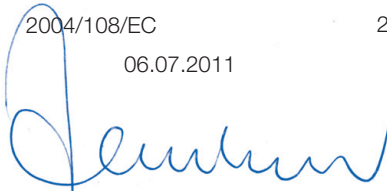

Jens Kruse

al cual se refiere esta de-
claración, está en conformidad
con la(s) siguiente(e) norma(s) u
otros documentos normativos

EN60079.0:2006, EN60079.11:2007
EN61000-6-1:2007
EN61000-6-3:2007

según las disposiciones de la(s)
directiva(s)

2004/108/EC

UL Approvals

UL-CUL listed, File # E 194021 UL 508/c22: 2 No. 142-M1987.

Contents

Introduction	5
Safety instructions	5
Repair	5
Hazardous areas	5
Product identification	6
Mounting	6
General	6
Explosion hazardous areas	6
Mechanical mounting	7
MJK 713 Flowmeter	7
Shuttle® Ultrasonic Sensor	7
Measuring distances for Parshall flumes	9
Measuring distances for Palmer & Bowlus flumes	9
Measuring distances for rectangular weirs	9
Measuring distances for V-notch weirs	9
Measuring along a wall or other plane	10
Flow measurement with smaller flumes / weirs	10
The spread of the ultrasonic signal	10
Measuring through a concrete deck	11
Measurement through a pipe for foam protection.	11
Model 3100 Hydrostatic Transmitter	12
Measuring distances for Parshall flumes	12
Measuring distances for Palmer & Bowlus flumes	12
Measuring distances for rectangular weirs	13
Measuring distances for V-notch weirs	13
Electrical mounting	14
MJK 713 System Package 1	14
MJK 713 System Package 2	14
MJK 713 System Package 3	14
Cable extension	15
Ultrasonic sensor	15
Cutting the cable	15
Hydrostatic transmitter	16
Cutting the cable	16
Display and keyboard	17
Quick start	17
Initial startup	18

Indications	19	Menu chart	27
		Indication menus	27
		Configuration menus	27
Function keys	20	Appendix	30
Flow key Q(t)	20	A Factory settings	30
Totalizer key SQ(t)	20	B Trouble shooting	31
Alarm key	21	C Technical specifications	32
Power loss alarm	21	D Hardware adjustments	33
Sample key	21	E System Package 2 -	
Menu key	22	Shuttle® used as signal amplifier	34
		F Max. head to max. nominal flow	37
System Configuration	23		
1.0 Set basic parameters	23		
1.1 Set date and time	23		
1.2 Access code enabled/disabled	23		
1.3 Enter new access code	23		
1.4 Select unit measurement	23		
1.5 Select unit volume	23		
1.6 Select unit flow rate	23		
2.0 Set sensor parameters	23		
2.1.1 Distance from zero to bottom of sensor	23		
2.1.2 Hydrostatic sensor range	23		
2.2 Level averaging	23		
3.0 Choose primary device	24		
3.1 Parshall flumes	24		
3.2 Palmer & Bowlus flumes	24		
3.3 V-notch weir	24		
3.4 Rectangular weir	24		
3.4.1 With or without contraction	24		
3.4.2 Rectangular weir crest width	24		
3.5 Q(h) linearization	24		
3.5.1 Number of Q(h) points	24		
3.5.2 Select decimal point for the flow values	24		
3.5.3 Linearization height value	24		
3.5.4 Linearization flow value	24		
3.6 Optional formula	24		
3.6.1 Optional formula - enter exponent	24		
3.6.2 Select decimal point for coefficient	24		
3.6.3 Optional formula - enter coefficient	24		
3.7 Flow range / level range	25		
4.0 Set digital output parameters	25		
4.1 Select digital outputs (1-5)	25		
4.2 Select function for DO	25		
4.3 Alarm flow rate low	25		
4.4 Alarm flow rate high	25		
4.5 Set volume between pulses	25		
4.6 Digital output ON-time	25		
4.7 Choose delay on signal	26		
4.8 Digital output NC/NO	26		
5.0 Analog output 0-20 / 4-20 mA	26		

Introduction

Thank you for choosing an MJK 713 Open Channel Flowmeter.

The MJK 713 Open Channel Flowmeter is a high quality flow measurement instrument, in which the relation between functions, userfriendliness and precision is optimum.

The MJK 713 Open Channel Flowmeter use either an ultrasonic transmitter or a hydrostatic pressure transmitter. This must be specified at time of ordering.

The MJK 713 Open Channel Flowmeter measures the flow rate of water or wastewater in all types of open weirs and flumes and provides a display of both current flow rate and totalized flow.

Yet MJK 713 is simple to set up and use in almost all applications, we recommend that you read this manual thoroughly in order to gain full use from the equipment.

You can always contact your representative or the MJK Service Hotline for advice and guidance. Also, take a look at www.mjk.com for additional product and application information.

MJK Automation A/S is a Xylem brand.

Safety instructions

- 1: Read this manual carefully.
- 2: Be aware of the environment on the installation site. Wear necessary protective equipment and follow all current safety regulations.
- 3: MJK 713 can provide a start signal for dangerous machinery. Always ensure that connected machinery and other equipment *are effectively being put out of service* (i.e. removal of main fuses, lock main and/or security switches in off position) before commencing installation, fault finding, service and maintenance work etc.
- 4A: MJK 713 model 2500: There is a risk of lethal electrical chock from terminal 1 to 5 and L-0. Be careful not to touch these while the unit is in service.
- 4B: MJK 713 model 3000: There is a risk of lethal electrical chock from terminal L-0. Be careful not to touch these while the unit is in service.

Repair

- 1: Repair of Ex approved equipment (ultrasonic transmitter) must only be made by MJK or by a service representative approved by MJK.

Hazardous areas

- 1: All current local and national standards, regulations regarding installation and use of Ex or hazardous zone approved equipment, certifications and safety instructions for Ex equipment, that have been used together with the installation of the *Shuttle*[®] ultrasonic transmitter must be strictly observed.

Product identification

General

A standard MJK 713 is delivered for two different measuring ranges (0 - 1 ft and 0 - 3 ft).

It is very important that the measuring range is correct for the flume in question in order to obtain maximum measuring accuracy.

Check that the item(s) delivered corresponds to the ordered item(s). The item number is printed on a label that is stuck onto the packing. Shown below is the label for a MJK 713 System Package 1 delivery including a MJK 713 flowmeter and a Shuttle® ultrasonic sensor:



- ① Item number
- ② Item description
- ③ Serial number
- ④ Software version



An identical marking can be found on the right hand side of the level transmitter cabinet:

Mounting

General

MJK 713 measures the flow in an open flume or weir based on the level of the head in the flume. The method of measurement are based on the following mathematical function:

$$Flow Q = f(head^x \times constant)$$

where the exponent x and the constant depends on the type of weir or flume.

The flow converter has 3 different linearization systems depending on how the volume of water is measured:

- preprogrammed formulas for different dimensions of the most common flumes and weirs, Parshall flumes, Palmer & Bowlus flumes, V-notch weirs, and rectangular weirs.
- for other flumes and weirs with a known calculation formula the exponent and the factor of the calculation formula can be set.
- for flumes where no calculation formula exists, a number of known flow values can be entered, on which a point linearization and curve extrapolation is calculated.

It is obvious that the flow calculation is highly dependant on the accuracy of the level measurement. It is therefore important to follow the mounting instructions carefully for the Shuttle® Ultrasonic Sensor (MJK 713 System Package 1 or 2) or MJK model 3100 Pressure Transmitter (MJK 713 System Package 3).

Explosion hazardous areas

The Shuttle® ultrasonic sensor is Ex approved and can be mounted in Zone 2 without the need of a zener barrier. It is not approved for Class I Division I zones.

The Flowmeter (= the electronic box with display) must not be mounted in explosive hazardous areas.

Mechanical mounting

MJK 713 Flowmeter

The MJK 713 Flowmeter is in NEMA 4X enclosure and can be mounted outdoors directly on a wall or in a panel using a panel mounting kit (order no. 200105). A sun shield (order no. 200115) is recommended in very sunny locations.

The MJK 713 Flowmeter must be mounted vertically in order to observe the NEMA4X standard.

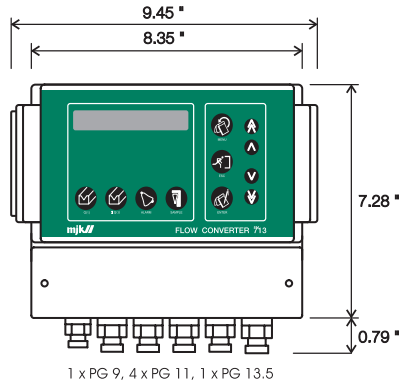

Mechanical dimensions for the MJK 713 Flowmeter.

The drawing below shows the drilling distances for mounting the cabinet on a wall:

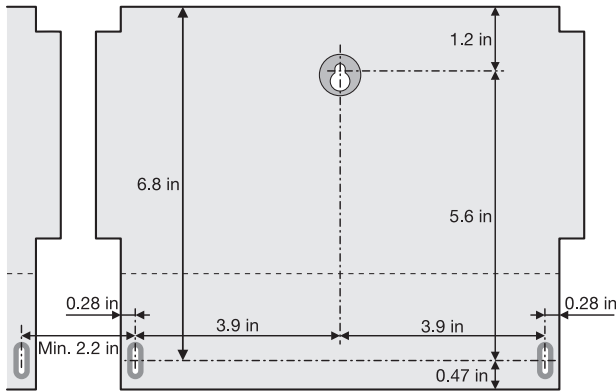

A full scale print of above drawing can be found at the end of this manual.

Shuttle® Ultrasonic Sensor

The following are extremely important when mounting the ultrasonic transmitter:

- 1: It should be mounted securely.
- 2: It should be mounted absolutely vertical. Use a spirit level in TWO directions.
- 3: It should be mounted in the correct distance from the bottom of the flume / weir. **Observe the blocking distance!**
- 4: It should be mounted in the correct distance from the inlet.

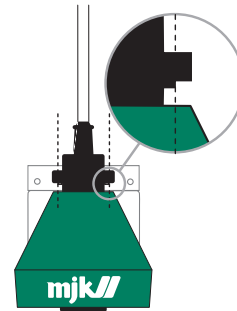

- 1: The ultrasonic sensor is equipped with a nut for bracket mounting. Note the recess on the nut - it must be fitted safely in the bracket for firm fixing to the bracket:

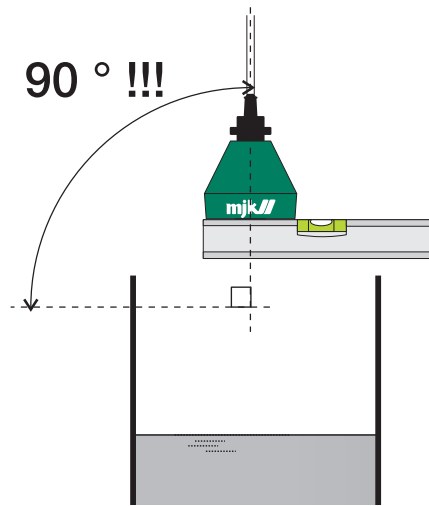

- 2a: To ensure a reliable and precise level measurement it is of vital importance that the ultrasonic sensor points down absolutely vertical against the liquid surface.

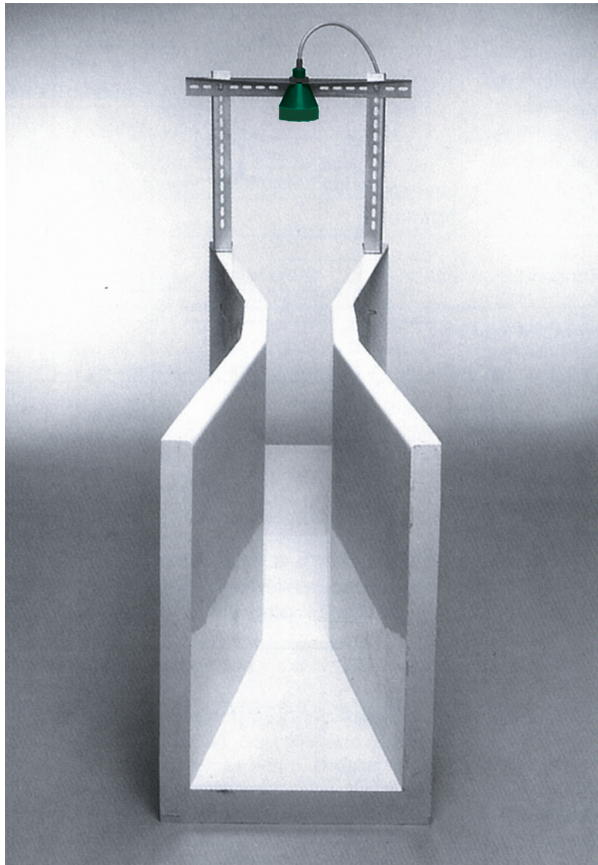

2b: We deliver two types of sensor brackets that can be used in almost any installation. The bracket shown is a flume mounting bracket (order no. 200230 / 200235).

3: The ultrasonic sensor should be installed so that the bottom of the sensor is as close as possible to the max. height of the head but *not closer than the blocking distance*.

Measuring range:	0 - 1'	0 - 3'
Blocking distance:)*	16"	16"
Min. measuring range:	4"	12"
Max. measuring range:	12"	36"
Max. sensor height ②:	30"	54"

)* 14" for System Package 2.
(w. Shuttle® Level Transmitter as signal amplifier.)

$$\text{Maximum sensor height } ② = \text{Blocking distance } ① + \text{measuring range } ④$$

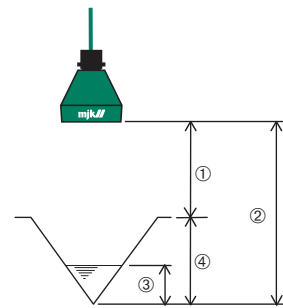

- ① Blocking distance
- ② Sensor height
- ③ Actual measurement
- ④ Measuring range

- 4: Mount the sensor in the correct upstream distance from the head in the flume / weir.
The distance depends on the dimension and type of flume / weir.

Measuring distances for rectangular weirs
- with and without side contraction

Measuring distances for Parshall flumes

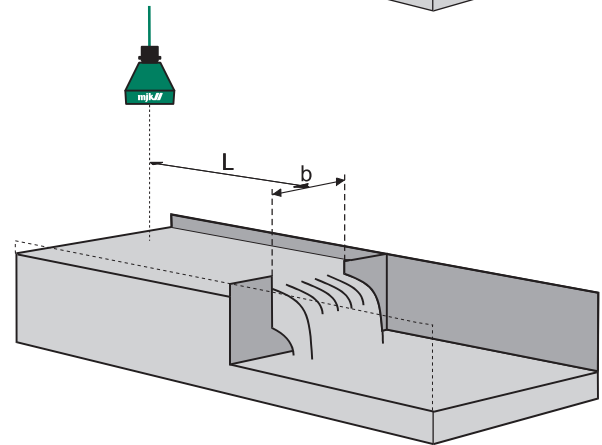
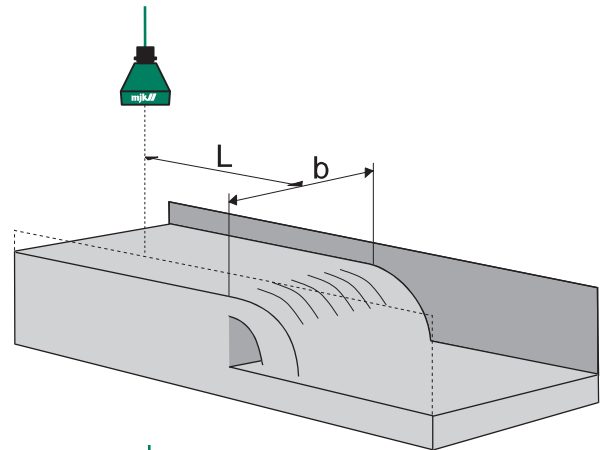
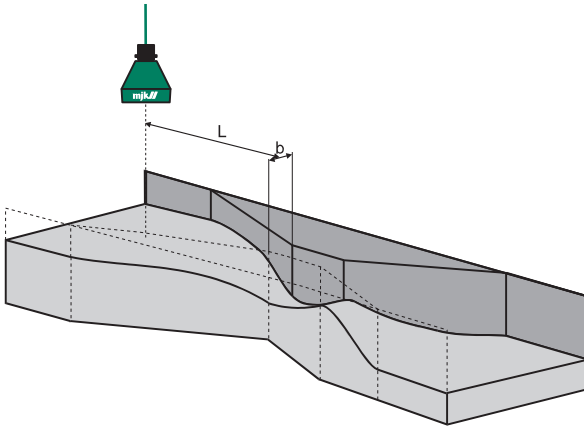

Throat width b:	Distance L:	Throat width b:	Distance L:
1"	10"	36"	43"
2"	11"	48"	47"
3"	12"	60"	51"
6"	16"	72"	56"
9"	23"	84"	59"
12"	36"	96"	63"
18"	37.5"	120"	72"
24"	39"	144"	80"

Measuring distances for Palmer & Bowlus flumes

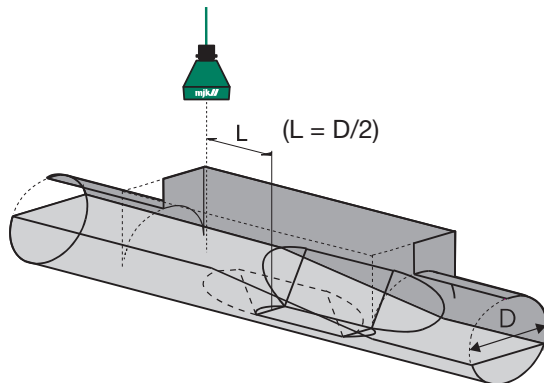

Diameter D:	Distance L:	Diameter D:	Distance L:
4"	2"	18"	9"
6"	3"	21"	10.5"
8"	4"	24"	12"
10"	5"	27"	13.5"
12"	6"	30"	15"
15"	7"		

The distance L should be between **4 to 5 times** the nominal width b.

Measuring distances for V-notch weirs

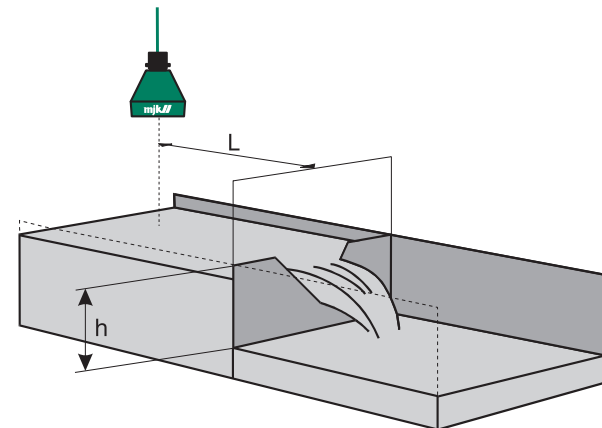

The distance L should be between **3 to 4 times** the height h of the notch.

Measuring along a wall or other plane

The values in table 1 assume the ultrasonic signal is sent along a *smooth surface like a wall or plane without any projections, joints, butts etc.*

If the surface is not smooth or has projections (i.e. joints on prefab elements), the ultrasonic signal will be impeded too much, and for that reason *the values for minimum distance to wall in table 1 should be increased with 50 - 100 % !*

Flow measurement with smaller flumes / weirs

Smaller flumes may cause problems if the ultrasonic signal reflects on the edges of the flume as shown below (fig. 2a).

The edges should be cut off (fig. 2c) or the ultrasonic sensor should be mounted in a pipe (fig. 2b) with smooth inner surface.

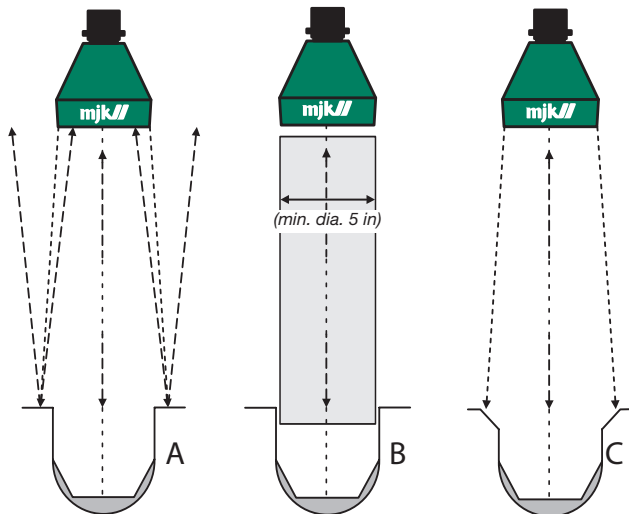

Figure 2: Use a pipe (B) or cut off the edges (C) on small weirs to prevent disturbing reflections from the flume edges.

The spread of the ultrasonic signal

The table and illustration below show the spread of the ultrasonic signal in conjunction to the measuring distance:

Measuring distance:	Beam spread:	Minimum distance to wall (from center line):
1'	5"	2.3"
2'	5"	2.6"
3'	6"	2.9"

Table 1: The ultrasonic signal spread along a smooth wall and minimum distance to center line in conjunction to the measuring distance.

Accordingly, as the measuring distance increases, the distance from the center line to a smooth wall should also be increased.

To avoid false echoes from e.g. edges, a minimum distance as shown on the drawing must be kept. The sensor can be mounted in a smooth pipe if the distance cannot be obtained. (See figure 1.)

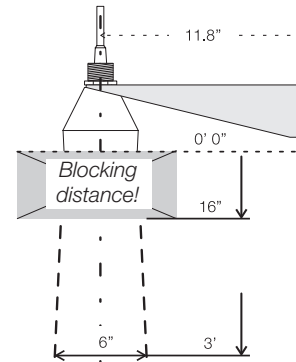
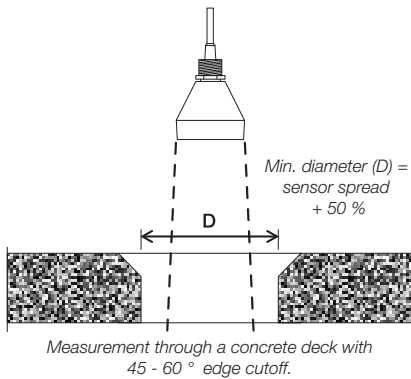
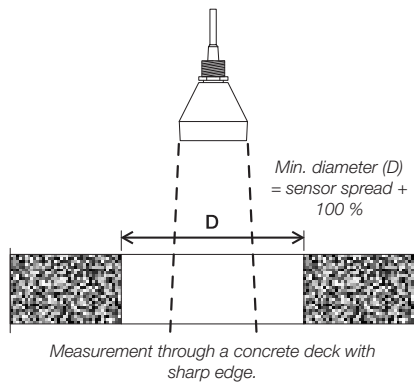

Figure 1: The signal spread in conjunction with the measurement distance. The signal spread should be increased by 50 - 100 % if the surface is not smooth!

Measuring through a concrete deck

When the ultrasonic sensor is measuring through a concrete deck, the dimension of the opening should be made as shown below: (See table 1 for the sensor spread.)



Measurement through a pipe for foam protection.

When measuring on liquids prone to build up foam on the surface, it can become necessary to measure through a pipe, since the build up of foam rarely will occur inside the pipe.

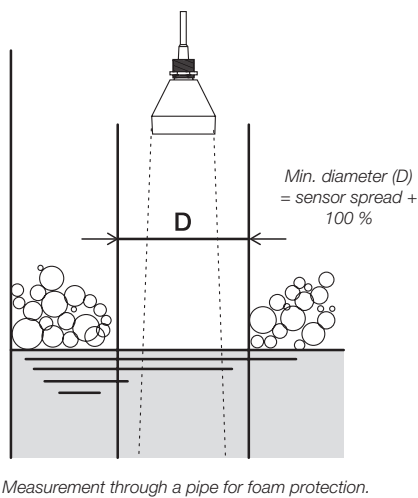

Model 3100 Hydrostatic Transmitter

The following directions should be followed when mounting the pressure transmitter:

- 1: It should be mounted securely - preferably on a pipe.

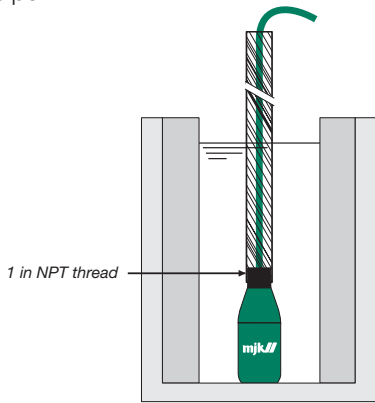

A 1 in pipe is used to prevent the pressure transmitter from hurling around in a Parshall flume.

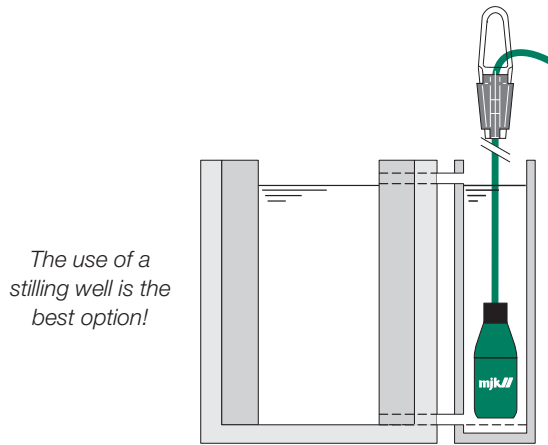

The use of a stilling well is the best option!

In case the water stream is so intense that the turbulence will affect the measuring accuracy, the pressure transmitter must be placed in a stilling well. **Note, that the transmitter should be positioned in the stilling well at the same height as the zero flow level!**

- 2: It should be placed in the correct height over the bottom of the flume / weir.

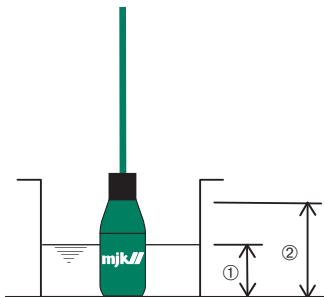

① Actual measurement ② Measuring range

- 3: Mount the transmitter in the correct upstream distance from the contraction in the flume / weir. The distance depends on the dimension and type of flume / weir.
- 4: Mount the transmitter at a location with no or very little turbulence - preferably in a stilling well placed in the correct distance from the contraction.

Measuring distances for Parshall flumes

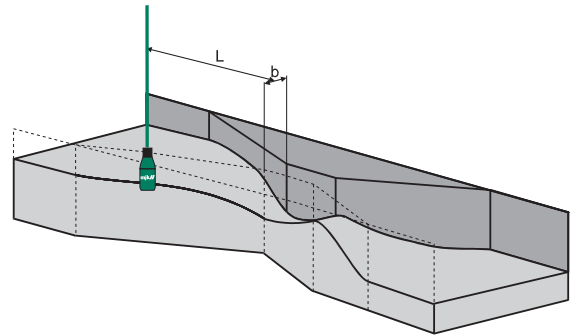

Throat width b:	Distance L:	Throat width b:	Distance L:
1"	10"	36"	43"
2"	11"	48"	47"
3"	12"	60"	51"
6"	16"	72"	56"
9"	23"	84"	59"
12"	36"	96"	63"
18"	37.5"	120"	72"
24"	39"	144"	80"

Measuring distances for Palmer & Bowlus flumes

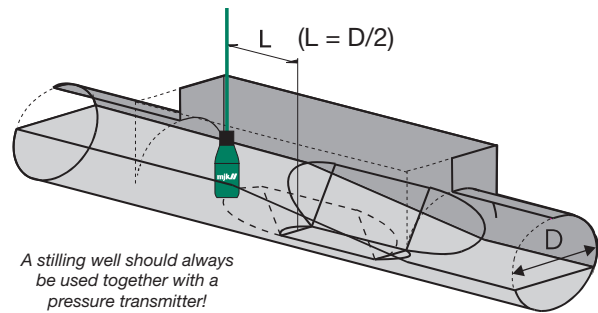

A stilling well should always be used together with a pressure transmitter!

Diameter D:	Distance L:	Diameter D:	Distance L:
4"	2"	18"	9"
6"	3"	21"	10.5"
8"	4"	24"	12"
10"	5"	27"	13.5"
12"	6"	30"	15"
15"	7"		

Measuring distances for rectangular weirs

- with and without side contraction

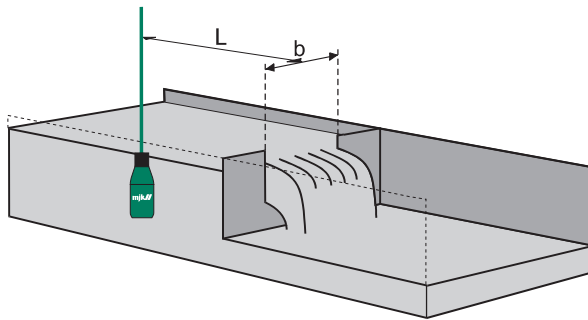
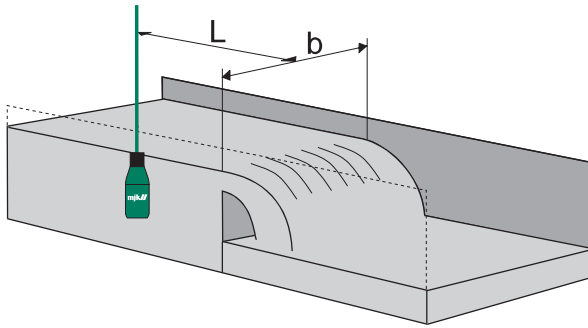

The distance L should be between *4 to 5 times* the nominal width b .

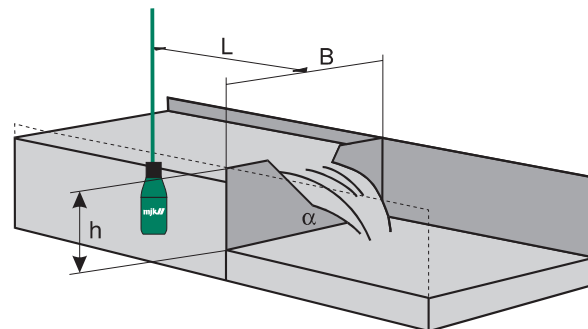
Measuring distances for V-notch weirs

The distance L should be between *3 to 4 times* the height h of the notch.

Electrical mounting

MJK 713 must not be connected to the power supply before the ultrasonic sensor / pressure transmitter is mounted and connected correctly.

MJK 713 is supplied from the mains on terminal "O" and "P".

Current regulations for conductor and fuse dimensions should always be observed.



Remove the lid to gain access to the terminals.

MJK 713 System Package 1

MJK 713 2500 with ultrasonic sensor

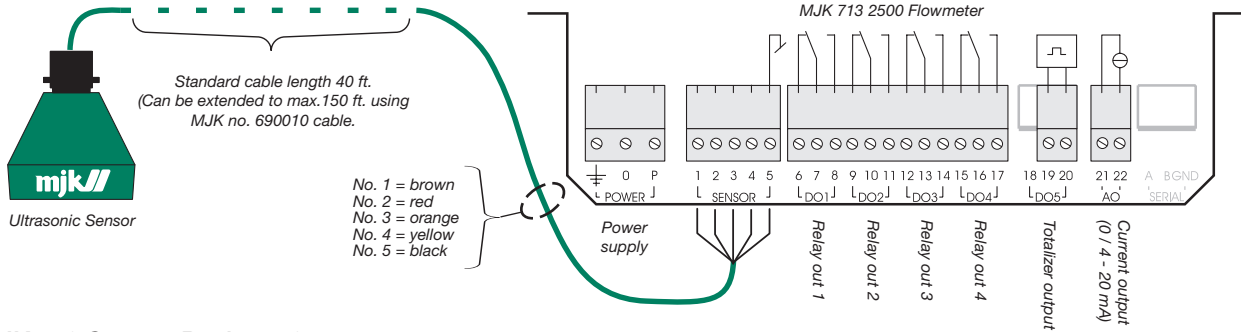

MJK 713 System Package 2

MJK 713 3000 with ultrasonic sensor using Shuttle® Level Transmitter as signal amplifier

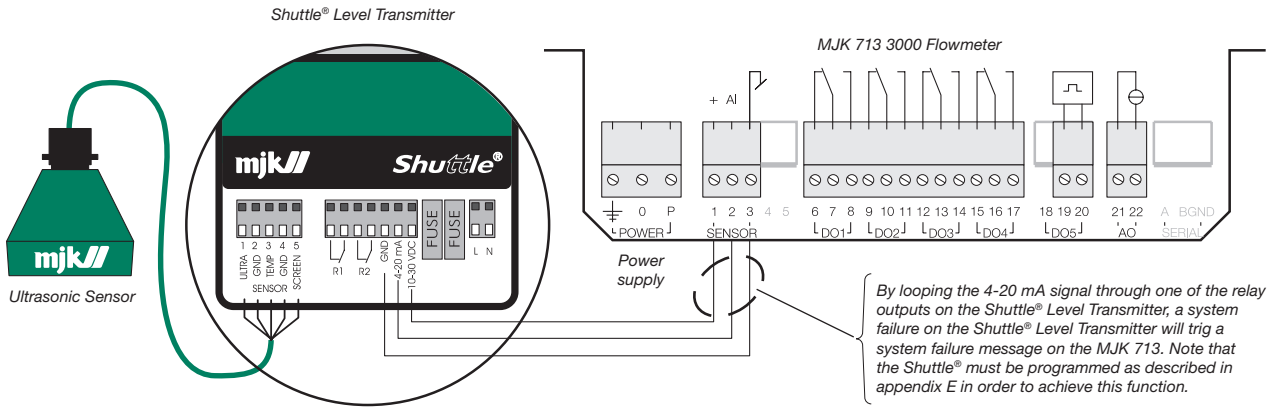

MJK 713 System Package 3

MJK 713 3000 with hydrostatic level transmitter

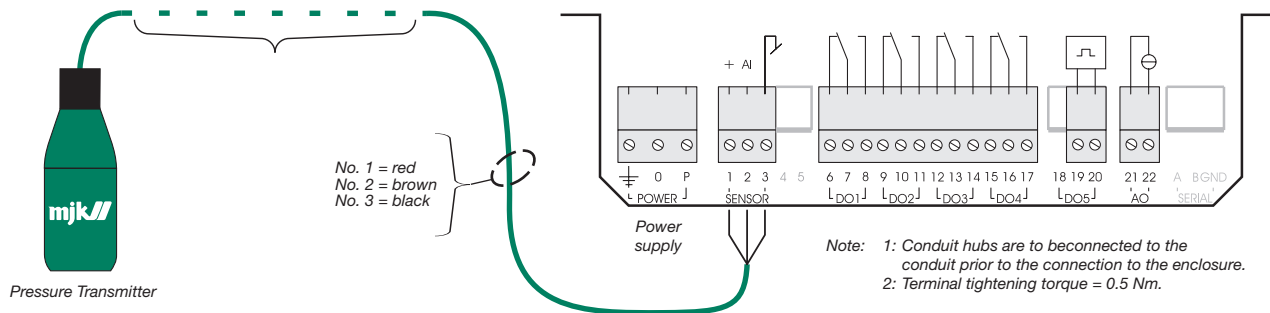

Cable extension

One of the most common faults on a MJK 713 installation is bad or faulty cable connections. It is recommended to use a MJK connection box if the sensor cable must be extended.

Ultrasonic sensor

The Shuttle® ultrasonic sensor are standard delivered with 40 ft of cable. The ultrasonic sensor can be delivered with up to 150 ft of cable on order, or the standard 40 ft cable can be extended to max. 150 ft.

The cable is a special low capacity cable, so extensions should always be made with the same type of cable.

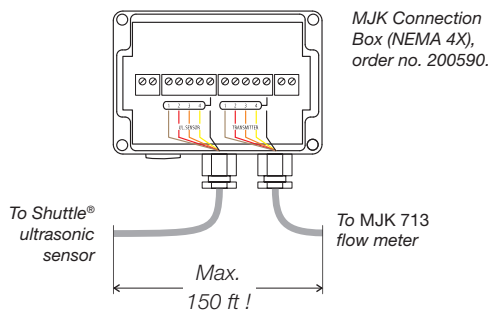

The ultrasonic sensor cable has 5 wires with both color code and number:

Number:	Color:	Designation:
1	Brown	Ultrasonic pulse
2	Red	
3	Orange	Temperature compensation
4	Yellow	
5	Black	Shield)*

)* This wire is connected to the cable shield.

The wires are mounted according to the terminal markings on the connection box PCB and on the MJK 713 respectively.

Cutting the cable

The cable is delivered with the wires stripped as shown with the black wire (no. 5) soldered to the shield:



When the cable is cut, only 4 wires will appear:

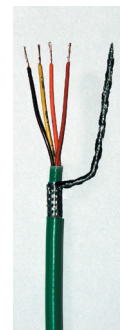

When the cable has been cut, the shield should be mounted in terminal 5 instead of the black wire !

When the ultrasonic sensor is mounted and connected correctly, the MJK 713 can be connected to the power supply.

See section 'Quick start' on page 18.

Hydrostatic transmitter

The pressure transmitter are delivered with 40 ft of cable as standard.
 The cable can be lengthened with any type of cable using MJK connection box 202922. Although the measuring signal is not sensitive to electrical noise, we recommend the use of a screened cable.

Ensure that no moisture can enter the pressure compensation tube inside the cable.

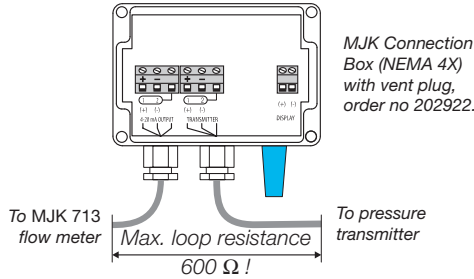

The factory delivered cable has three wires marked with the numbers 1 - 2 - 3.

Number:	Color:	Designation:
1	Black	Positive (+) wire
2	Black	Negative (-) wire
3	Black	Shield)*
4	-	Air pressure compensation tube

)* This wire is connected to the cable shield.

The wires are mounted according to the terminal markings on the connection box PCB and on the MJK 713 respectively.

Take care not to block or squeeze the air pressure compensation tube ④.

Cutting the cable

The cable is delivered with the wires stripped as shown with wire no. 3 soldered to the shield:

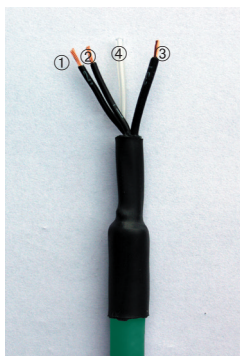

When the cable is cut, 7 wires will appear:

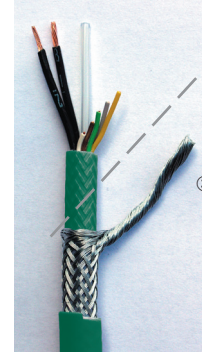

When the cable has been cut, the shield should be mounted in terminal 3 instead of the black wire !

The small-gauged colored wires MUST NOT be used or short circuited as it may damage the pressure transmitter.

The colored wires should be cut off in different lengths to prevent them from short circuit.

See also separate instruction manual for the MJK pressure transmitter.

When the pressure transmitter is mounted and connected correctly, the MJK 713 can be connected to the power supply.

See section 'Quick start' on page 18.

Display and keyboard

Display

2 x 24 character backlit display for indication of menus and values.

ESCape

This key allows you to change back to the main menu or to undo a new choice. By pressing the ESCape button two or three times, you will return to the function indications. If you think you are lost, or you think you made a mistake, simply press this button a few times to start over. However, the escape function is disabled when choosing primary device.

MENU

By pressing the MENU key, the display will change to the next main menu.

Arrow keys

The arrow keys are used for changing a current setting.

Pressing the arrow keys change the values up or down. By pressing the "up" arrow keys, the number in the display will increase.

Pressing the "down" arrow keys will decrease the value.

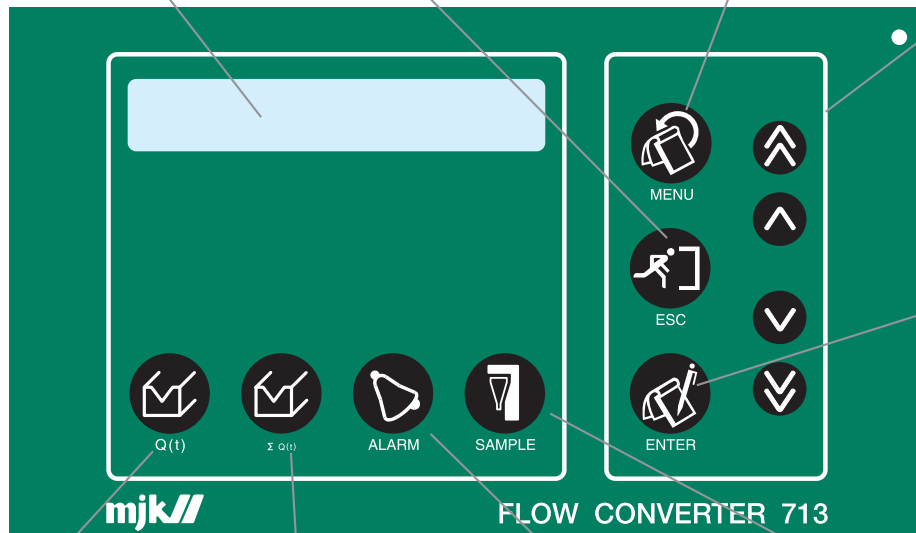
**ENTER**

This key allows you to change between the main menu to a sub-menu, as well as between sub-menus.

The key also allows you to confirm the choice from a sub-menu.

Q(t)

Registers for flow rate:

- instantaneous value
- average flow rate for the last 1 hour
- average flow rate today
- average flow rate for the last 24 hours

Σ Q(t)

Registers for:

- total flow
- total flow 1 hour
- total flow today
- total flow 24 hours
- 99 days log

ALARM

Alarm record with the previous nine alarms incl. date and time of occurrence.

SAMPLE

Registration of:

- total number of samples
- number of samples today
- number of samples within the last 24 hours

Quick start

When MJK 713 is powered up for the first time, a quick setup sequence will be initiated that will guide you through the following basic settings needed for most installations:

- 1: selection of primary device / flow calculation formula
- 2: max. flow range
- 3a: ultrasonic transmitter distance (applies to MJK 713 2500 / System Package 1 only)

- 3b: hydrostatic sensor range (applies to MJK 713 3000 / System Package 2 & 3 only)

After these initial settings has been made, MJK 713 will automatically begin to measure flow. If you wish to take advantage of the flow converter's many other advanced functions, such as flow proportion sampling, the remaining sections of this manual will help you to configure the unit.

Initial startup

MJK 713 will show the following display at power-up:

```
MJK 713 PROGRAM   XXXXX
STARTUP          WAIT A MOMENT
```

MJK 713 initiates the quick setup sequence after app. 30 sec:

```
WELCOME TO MJK 713
TO START PRESS ENTER

TO CHOOSE USE ARROWS
TO CONFIRM PRESS ENTER
```

The following menus is only shown the first time MJK 713 is powered up and will not appear again after the initial quick setup sequence unless the quick start sequence is initiated again by holding ALARM + SAMPLE simultaneously and pressing ENTER while in level readout menu.

This is shown when ENTER is pressed the first time.

1:

```
SELECT PRIMARY DEVICE
```

Select flume/weir or flow calculation formula with arrow keys and confirm with ENTER. Choose between *Parshall flume*, *Palmer & Bowlus flume*, *V-notch weir*, *rectangular weir* or *optional formula*.

Depending on the selection of flume/weir type or calculation method, a number of menus for setting some specific information may appear.

No matter which primary device being selected, the following will be displayed as the last:

2:

```
MAX. FLOW      XXX.X MGD
AT MAX. LEVEL  XXX.X IN
```

In this menu the maximum flow for the selected primary device should be set in accordance with the value stated in the tables in Appendix E.

It is very important to set the correct maximum flow value, since it will dramatically reduce measuring errors!

Set the desired max. flow range for the installation with the arrow keys and confirm with ENTER.

MJK 713 will now calculate the max. level related to the selected primary device and display the result in the second line.

The max. flow range determines the range of the mA output. MJK 713 will calculate the max. level based on the desired max. flow for the selected primary device, and set the analog output to give out 20 mA at the max. flow. (The setting is also used internally to monitor the functions of the flow meter.)

This menu will appear for a MJK 713 2500 / System Package 1:

3a:

```
DISTANCE FROM ZERO TO
BOTTOM OF SENSOR XX.X IN
```

Set the distance from the zero point (= zero flow level in flume/weir) to the bottom of the ultrasonic sensor with the arrow keys and confirm with ENTER.

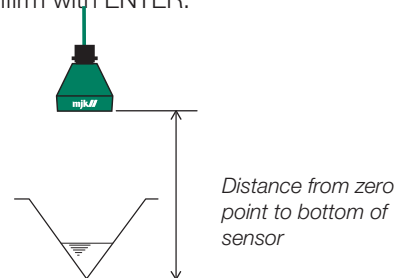

This menu will appear for a MJK 713 3000 / System Package 2 & 3:

3b:

```
PRESSURE TRANSMITTER
RANGE 0-X.XX FT
```

Set the measuring range for the hydrostatic pressure transmitter with the arrow keys and confirm with ENTER.

The basic data entries is now finished and MJK 713 starts to measure the flow.

```
05:10:49 PM 06/16/02
FLOW RATE: 26.0 GPM
```

To take advantage of MJK 713's many advanced functions, please see the system configuration section starting on page 23.

Note: For System Package 2 (MJK 713 3000 with Shuttle® Level Transmitter as signal amplifier: See appendix E for the necessary settings for the Shuttle® Level Transmitter

Note: "Quick Start" sequence can be initiated again by holding ALARM + SAMPLE simultaneously and pressing ENTER while in level readout menu.

Indications

At the front of the flow converter, there are 4 function keys: the flow rate key **Q(t)**, the totalizer key $\Sigma Q(t)$, the alarm key **ALARM** and the sample key **SAMPLE**.

When one of these keys is pressed one or more times, the different function menus appear. The menus available depend on how you configure the flow converter.

Configuring the flow converter is accomplished in the configuration menus, which in turn are divided into several sub-menus. You gain access to the configuration menus by pressing the MENU key. In each menu the different settings are obtained by pressing the arrow keys.

Note: A complete diagram of the menus can be found in the back of this manual. This diagram will be very helpful to you if you choose to configure the flow converter!

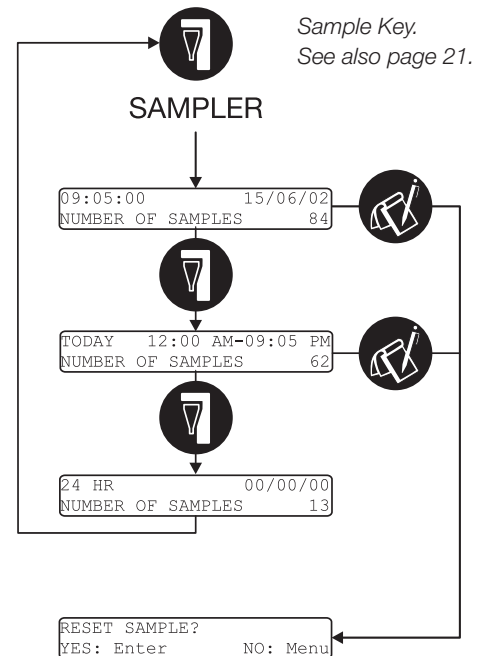
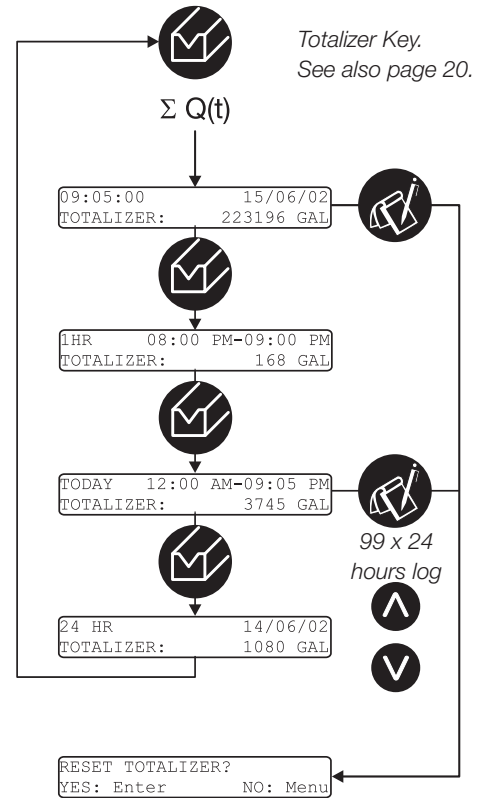
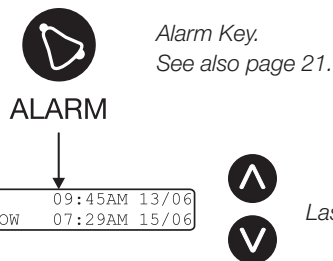
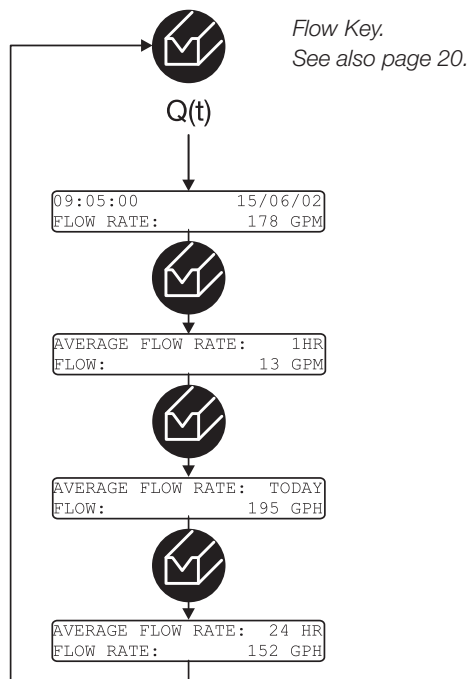

Function keys



Flow key Q(t)

This key shows the values of the relevant flow, as well as various average values.

F1 Flow

Press once for:

12:34:12 PM	06/14/02
FLOW RATE:	23196 GPM

Here the instantaneous actual flow is shown. The flow is calculated from the chosen Q(h)-formula. Measuring value with time and date is indicated.

F2 Average flow 1 HR

Press twice for:

AVERAGE FLOW RATE:	1 HR
FLOW RATE:	20 GPM

Here the average flow for the last full hour is indicated.

F3 Average flow today

Press three times for:

AVERAGE FLOW RATE:	TODAY
FLOW RATE:	3520 GPM

Here the average flow from 12:00:00AM to the current time is indicated. The display is updated every second.

F4 Average flow 24 HR

Press four times for:

AVERAGE FLOW RATE:	24 HR
FLOW RATE:	120 GPM

Here the average flow for the last full 24 hours is indicated (12:00:00AM to 11:59:59PM).

Totalizer key SQ(t)



This key will give access to indication of summed quantities.

F5 Totalizer

Press once for:

12:34:12 PM	06/14/02
TOTALIZER:	846255 GAL

Here the total quantity is indicated, from when the value was last reset. The quantity is updated every second and is indicated with time and date. The value is reset by pressing ENTER.

F6 Totalizer 1 hour

Press twice for:

1 HR	11:00 - 12:00 PM
TOTALIZER:	77376 GAL

Here the summed quantity for the previous full hour is indicated (e.g. 11:00AM -12:00PM).

F7 Totalizer today

Press three times for:

TODAY	12:00 - 01:51 PM
TOTALIZER:	637 GAL

Here the summed quantity for today is indicated. The result along with the time interval is updated every second. The value is reset by pressing ENTER.

F8 Totalizer 24 hour 99 days log

Press four times for :

24 HR	06/14/02
TOTALIZER:	83152 GAL

Here the 24 hours summed quantity log is indicated. The quantity and the date for the previous day are logged every 24 hours (12:00:00AM). The log goes back 99 days. The arrow keys are used for accessing the log. Note, that the MJK 713 must have been in service for at least 24 hrs before the last 24 hr log will contain valid data, and at least 99 days before the full 99 days log will contain valid data.



Alarm key

The digital outputs can be configured as alarms of one of the following alarm types: high flow, low flow and sensor error. In addition a Power Loss alarm is generated if the power supply to the flow converter is interrupted. Press the alarm key to see the previous nine alarms. A new alarm is registered as alarm no 1, the other alarms are moved one place, and the alarm which was previously registered as alarm no 9 is erased.

F9 Alarm display

After pressing the key once alarm no. 1 is shown, which is the latest alarm; press again and alarms 2-9 come up. By using the arrow keys it is possible to move backwards and forwards between the alarms.

The instant an alarm is registered, the alarm type, the digital output and the time is shown on the display:

```
ALARM 1: D3 12:16PM 03/25
FLOW HIGH
```

When the alarm is no longer active, the time of switch off is registered. Beware that different alarms could have been activated in the meantime, meaning the alarm is no longer no. 1:

```
ALARM 2: D3 12:16PM 03/25
FLOW HIGH 05:11AM 03/25
```

Power loss alarm

```
ALARM 3: D3 01:58AM 03/25
POWER LOSS 02:44AM 03/25
```

Start of power loss is registred with a precision of 5 min. End of power loss is registred when the flowmeter is powered up. The upper line in the display shows the time for starting the alarm. The bottom line shows the time for stop. When an alarm is detected only the time for start is shown in the upperline of the display, signaling that the alarm has not disappeared. When a new alarm appears the display will change from the previous chosen main menu to F9 - alarm indication, alarm.



Sample key

If one or more of the digital outputs are configured for controlling a sampler, pressing this key will give following indications:

F10 Number of samples

Press once for:

```
04:39:12AM 02/22/02
NUMBER OF SAMPLES 34245
```

This display indicates how many samples have been taken since last reset or system start up. Press ENTER for reset, see menu F13.

F11 Number of samples today

Press twice for:

```
TODAY 12:00AM - 05:22PM
NUMBER OF SAMPLES: 45
```

This display indicates how many samples have been taken today (12:00 AM - now). Press ENTER for reset, see menu F13.

F12 Number of samples 24 HR

Press three times for :

```
24 HR: 02/22/02
NUMBER OF SAMPLES: 11
```

This menu indicates how many samples were taken yesterday. Value and date for the previous 24 hours are indicated.



F13 Reset

Some counter values can be set at 0-level by using the enter key. One of the following menus will appear:

```
RESET SAMPLE?
YES: Enter NO: Menu
```

```
RESET TOTALIZER?
YES: Enter NO: Menu
```

When a counter has reached its max. value a negative number is shown. Then reset the counter as described in F13.



Menu key

This key gives access to the configuration menus with readout and programming of the submenus.

A selection is made with the arrow keys (up or down) and confirmed with the “ENTER” key. Non-confirmed selections will flash in the display, whereas a current/confirmed selection is shown non-flashing.

Level

Press MENU once for:

```
LEVEL=1.80 IN   I=12.3 mA
D1=0 D2=0 D3=1 D4=1 D5=0
```

Here the measured level (LEVEL) and the value for the analogue output (I) is indicated. The digital outputs are indicated as D1-D5. “0” indicates non-activated output, whereas “1” indicates activated outputs.

Language

Press MENU twice for:

```
LANGUAGE          ENGLISH
```

Change the language with the arrow keys and confirm with ENTER.

Enter access code

Press MENU three times for:

```
KEY IN ACCESS CODE
USE ARROW KEYS
```

The remaining configuration menus can be protected with a 4-digit access code. Enter the access code with the arrow keys and press “ENTER”. Double arrows changes the first two digits, single arrows changes the last two digits.

When the access code is keyed in, access to the remaining configuration menus will be given for 5 min. since last key pressed.

The access code 1111 can always be used.

Access denied

What happens when the wrong access code is keyed in:

```
ACCESS NOT ALLOWED
```

It will not be possible to make changes in the setup. Return to the previous chosen menu by pressing the ESC key once.

System Configuration

1.0 Set basic parameters

Access to the configuration menus are obtained by pressing ENTER twice.

1.1 Set date and time

Time and date is adjusted with the arrow keys, followed by ENTER.

1.2 Access code enabled/disabled

The remaining configuration menus can be protected by an access code to prevent unauthorized access to the configuration menus. It will still be possible to operate MJK 713's normal functions and readouts. Select function with the arrow keys and confirm with ENTER.

1.3 Enter new access code

If access code is enabled this menu displays a chosen access code (4 digits) for access to the configuration menus. Double arrows changes the first two digits, single arrows changes the last two digits. Change the code and confirm with ENTER.

1.4 Select unit measurement

Level indication and unit of elevation can be chosen as:

m, cm, mm, ft, in

Select with the arrow keys and confirm with ENTER.

1.5 Select unit volume

The unit for volume can be chosen between:

m³, Gal, CF

Select with the arrow keys and confirm with ENTER.

1.6 Select unit flow rate

The unit for flow can be chosen between:

l/s, m³/h, GPM, CFS, MGD

2.0 Set sensor parameters

Access is obtained by pressing ENTER. Press MENU once to enter the main menu.

2.1.1 Distance from zero to bottom of sensor

(MJK 713 2500 only.)

Enter the distance from the bottom of the ultrasonic sensor to the actual zero point. Double arrows changes the first two digits, single arrows changes the last two digits. Set the distance and confirm with ENTER.

2.1.2 Hydrostatic sensor range

(MJK 713 3000 only.)

Select the measuring range for the hydrostatic sensor with the arrow keys and confirm with ENTER.

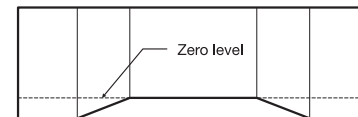

Zero level for Palmer & Bowlus flume.

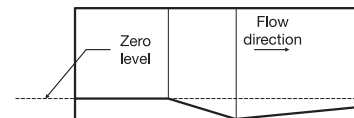

Zero level for Parshall flume.

2.2 Level averaging

This menu sets the interval for averaging the level measurement. The interval can be set between 1 and 60 seconds. Select the interval with the arrow keys and confirm with ENTER.

3.0 Choose primary device

Select the type of flume/weir or flow calculation formula. 6 options are available: Parshall flume, Palmer & Bowlus flume, V-notch weir, rectangular weir, linearization and optional flow formula. Select the desired flume/weir or flow calculation formula with the arrow keys and confirm the selection with ENTER.

Note that entering this menu will force you to go through all submenus concerning the selected flume / flow calculation formula.

3.1 Parshall flumes

For Parshall flumes there is a choice between the following standard sizes: 1", 2", 3", 6", 9", 12", 18", 24", 36", 48", 60", 72", 96", 120", and 144".

Select the size with the arrow keys and confirm with ENTER.

3.2 Palmer & Bowlus flumes

For Palmer & Bowlus flumes there is a choice between the following standard sizes: 4", 6", 8", 10", 12", 15", 18", 21", 24", 27" and 30". Select the size with the arrow keys and confirm with ENTER.

3.3 V-notch weir

Set the notch angle α between 22,5 and 120 degrees with the arrow keys and confirm with ENTER.

3.4 Rectangular weir

Select this menu for rectangular weirs with and without side contraction.

3.4.1 With or without contraction

Select if the weir has a contraction or not.
See also page 9.

3.4.2 Rectangular weir crest width

Set the width b (see page 9) of the weir and confirm with ENTER.

3.5 Q(h) linearization

This menu is used for entering a customized Q(h) linearization based on up to 10 linearization points.

3.5.1 Number of Q(h) points

Enter the number (from 1 to 10) of Q(h)-points for the linearization with the arrow keys and confirm with ENTER. The selected number of Q(h) points decides how many times the menus 3.5.3 to 3.5.4 will appear.

3.5.2 Select decimal point for the flow values brand

Select the decimal point and 10/100/1000 multiplier for the flow points between

$X.XXXX$ and $XXXXX000$

with the arrow keys and confirm with ENTER.

3.5.3 Linearization height value

Set the level [h] for a Q(h) point with the arrow keys and confirm with ENTER. The level unit will be the unit selected in menu 1.4.

Note: Always start with the lowest value, then the next and so on until the largest value is reached. The height 0 has a default flow of 0. The highest Q(h)-point automatically gives the measuring range.

The level value can be set within the level span.

3.5.4 Linearization flow value

Set the volume [Q] for the corresponding Q(h)-point with the arrow keys and confirm with ENTER. The volume MUST be greater than the value previously entered. The volume unit will be the unit selected in menu 1.6.

3.6 Optional formula

This menu is used for entering the coefficient K and exponent x in the basic flow formula $Q(h) = K \times h^x$.

Q is the flow in the chosen flow unit, h presents the level in the chosen measurement unit, K is a factor between 0.000,01 and 6,500,000 and x is the exponent between 1 and 3.

3.6.1 Optional formula - enter exponent

Set the exponent x for the flow calculation formula with the arrow keys and confirm with ENTER. Double arrow changes the value fast and single arrow changes the value slowly.

3.6.2 Select decimal point for coefficient

Select the decimal point / leading zero for the coefficient for the flow formula. Select between

$0.XXXXX$ and $XXXXX$

with the arrow keys and confirm with ENTER.

3.6.3 Optional formula - enter coefficient

Set the factor K with the arrow keys and confirm with ENTER. The factor can be set within 0.00001 to 6,500,000.

3.7 Flow range / level range

MAX. FLOW	XXX.X MGD
AT MAX. LEVEL	XXX.X IN

This menu is mainly used to set the span of the mA output in relation to the calculated flow, but can also be used to check the flow calculation in relation to the measured level based on the formula for the selected primary device / flow calculation.

Simply enter the flow with the arrow keys and press ENTER, and MJK 713 calculates the corresponding level.

The mA output span is set by entering the flow value where the mA output should give out 20 mA.

An example: If a 12" Palmer & Bowlus flume is selected as primary device, the nominal maximum flow will be 881 GPM at a level of 9.1 in.

If the flow range value is set to 881 in this menu, MJK 713 calculates the level, the mA output will give out 20 mA at max. nominal flow and 4 / 0 mA at zero flow.

If the flow range value is changed to 400 GPM, the mA output will give out 20 mA at 400 GPM and upwards and 4 / 0 mA at zero flow.

4.0 Set digital output parameters

Press ENTER for configuring digital outputs or press MENU for MAIN MENU

4.1 Select digital outputs (1-5)

Configuring of the five digital outputs. Select with the arrow keys which digital output to program, confirm with ENTER.

Digital output 5 (DO5) is output for an external counter.

4.2 Select function for DO

For digital output 1-4 select with arrow keys between various functions: counter output, sampler, flow > 0%, flow high, flow low and alarm sensor error. The choice is confirmed with ENTER.

Counter output:	After a preset quantity the output is activated to trig an external counter.
Sampler:	After a preset quantity the output is activated to trig a sampling device or a chemical dosing device.
Flow > 0%:	Signal to indicate that the flow is greater than 0 is applied, i.e. when measuring emergency stormflow.
Flow rate high:	Activated if flow exceeds a given flow rate.
Flow rate low:	Activated if flow drops below a given flow rate.
Sensor error:	Activated at sensor error. Factory default is 5 minutes without an approved sensor signal.
Output disabled:	Output not used.

4.3 Alarm flow rate low

The limit for flow low is keyed in using the arrow keys. The span is 0 - 90 % of max. flow.

4.4 Alarm flow rate high

The limit for high flow is keyed in using the arrow keys. The span is 10 - 100 % of max. flow.

4.5 Set volume between pulses

The volume that passes between each time a pulse is sent to a DO is keyed in. The interval between the pulses is limited to min. 1 sec.

4.6 Digital output ON-time

The ON time for the DO is keyed in using the arrow keys. Double arrow changes the value fast with 1 sec. jumps. Single arrow changes the value slowly with 0.1 sec. jumps. The range is 0.1 - 30 sec.

4.7 Choose delay on signal

The time limit for an alarm must be exceeded before a DO is activated.

The format is as follows - min:ss The maximum delay is 99 minutes and 59 seconds.

4.8 Digital output NC/NO

The relay function for digital output is keyed in, as Normally Open (NO) or Normally Closed (NC). Select with arrow keys, confirm with ENTER.

5.0 Analog output 0-20 / 4-20 mA

Select between 0-20 or 4-20 mA output. Select with arrow keys, confirm with ENTER.

Menu chart

Indication menus

Configuration menus

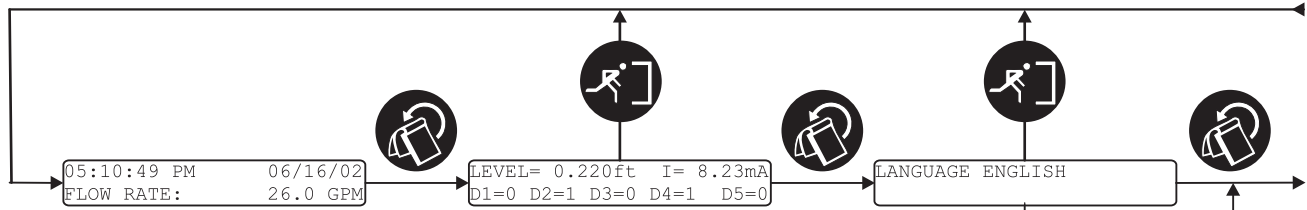

Q(t)

Flow rate key

Press 1 X: Average flow rate 1 hr
 Press 2 X: Average flow rate today
 Press 3 X: Average flow rate 24 hr



Σ Q(t)

Totalizer key

Press 1 X: Totalizer 1 hr
 Press 2 X: Totalizer today
 Press 3 X: Totalizer last 24 hr



In the last selection the totalizer values for the last 99



days can be displayed using the arrow keys.



ALARM

Alarm key

Press 1 X for alarm list with last 9 alarm log.



Toggle alarms with arrow keys.



SAMPLER

Sampler key

Press 1 X: Total number of samples
 Press 2 X: Number of samples today
 Press 3 X: Number of samples last 24 hr

Configuration menus

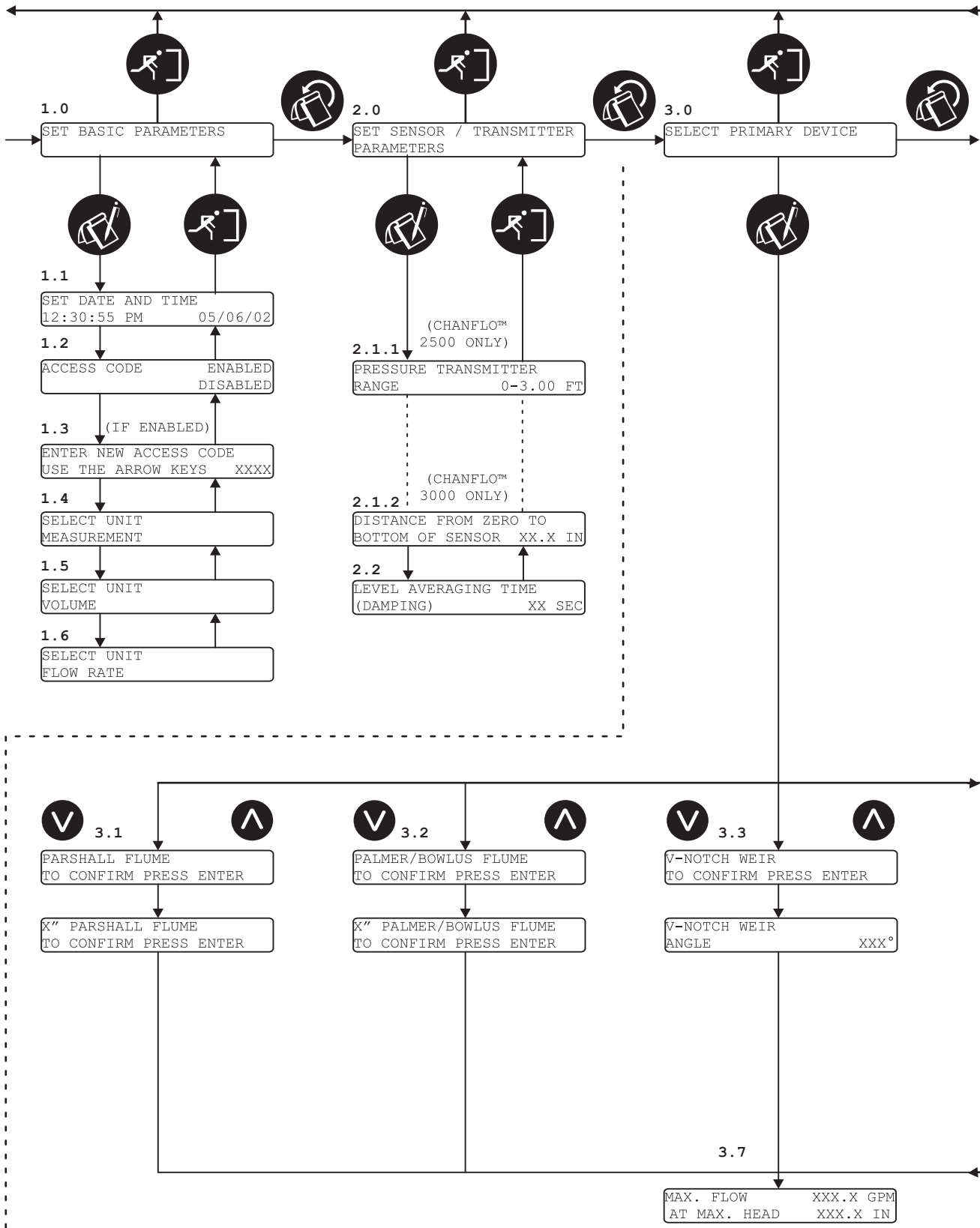

Configuration menus

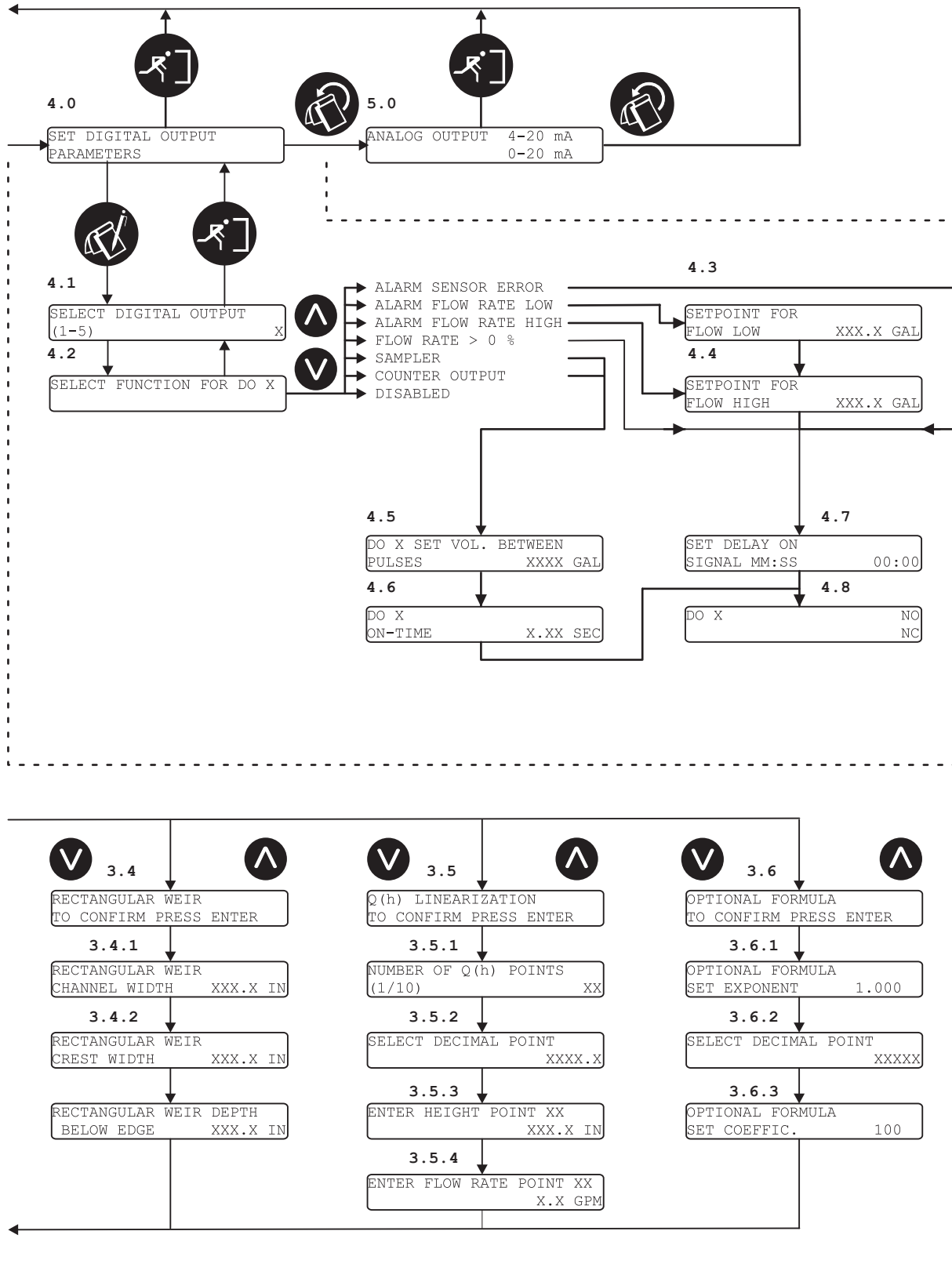

Appendix A
Factory settings

Basic parameters:	Factory setting:	Current settings:
Access Code:	Disabled (Code: 1111)	
Measurement Level:	Inches	
Measurement Volume:	Gallons	
Measurement Flow:	MGD	
Sensor distance:	30 in / 54 in*	
Averaging of Level:	1 sec.	
Range for flow:	1,000 MGD / 10.00 MGD*	

Flow Calculations

Parshall Flume:	6" range (10 in):
Palmer & Bowlus Flume:	10" range (10 in):
V-notch:	90 °
Rectangular	Crest width = 10.00 in
Optional Formula:	Exponent = 1.000, Factor= 0.100

Digital output

DO1:	Disabled (On-time = 0.5 sec)
DO2:	Disabled (On-time = 0.5 sec)
DO3:	Disabled (On-time = 0.5 sec)
DO4:	Disabled (On-time = 0.5 sec)
DO5:	Counter 10.000/100.000 GAL* On-time = 0.5 sec

Analog output

AO:	4 - 20 mA
-----	-----------

* Depending on measuring range.

Appendix B

Trouble shooting

INDICATION	CHECK	CAUSE / REMEDY	
The display is not lit	Power supply	Wire mounting	Are minimum ¼ in of the insulation removed and the lead firmly mounted?
		Power supply	Is the correct live voltage present between terminals marked '0' and 'P'? Is the PSU primary fuse (200 mA @ 115 V AC) intact? Remove the four retaining screws from the front panel and remove the front panel. The fuse is located on the left hand side below the transformer on the lower PCB. Exchange if necessary.
713 indicates system error	Liquid surface	Signal strength	Is the liquid surface foamy? Try increasing the strength of the ultrasonic signal by turning the 'Gain' potentiometer clockwise. Remove the four retaining screws from the front panel and remove the front panel. The potentiometer is located on the lower PCB - see appendix D.
		Level averaging	Is the liquid surface unsteady? Try increasing the setting for level averaging - see section 2.2.
	Shuttle® Ultrasonic Sensor - Pressure Transmitter	Wire mounting	Are the wires connected to the correct terminals? See connection diagram.
		Cable extensions	Is there water in the connections? Are the extensions made correctly? Check cable type and length. It is recommended to use a Danfoss connection box when extending cables.
	Shuttle® Ultrasonic Sensor	Condition	Is the black part of the sensor miscoloured or cracked? Miscolouring indicates that the sensor is not suited for the environment on the installation site.
		Function	Is the sensor transmitting clicking sounds? If not, the sensor is faulty.
		Sensor mounting	Is the sensor mounted ABSOLUTELY VERTICAL? It is extremely important that the sensor is firmly mounted in a vertical position. See section 'Mechanical mounting of Shuttle® Ultrasonic Sensor'.
		Measuring distance	Is the sensor mounted so the measuring distance is more than 16 in and less than 1 ft / 3 ft ? The maximum / minimum measuring range must not be exceeded.
Level read-out is not changing	Shuttle® Ultrasonic Sensor	Sensor mounting	Is the sensor mounted ABSOLUTELY VERTICAL? It is extremely important that the sensor is firmly mounted in a vertical position. See section 'Mechanical mounting of Shuttle® Ultrasonic Sensor'.
		Installation site	Is there an obstruction (eg. big fatty accumulations or other objects) disturbing the ultrasonic signal?
Level read-out is wrong	Shuttle® Ultrasonic Sensor	Sensor mounting	Is the sensor mounted ABSOLUTELY VERTICAL? It is extremely important that the sensor is firmly mounted in a vertical position. See section 'Mechanical mounting of Shuttle® Ultrasonic Sensor'.
		Cable	Is the sensor cable extended with a non-approved cable type and/or extended beyond 150 ft?

Appendix C
Technical specifications

Ultrasonic Sensor - one year warranty	
Measuring range:	0 - 1 ft., 0 - 3 ft., 0 - 10 ft.
Frequency:	30 / 75 kHz
Beam angle:	3 / 7 °
Temperature range:	- 5 to + 150 °F
Accuracy:	≤ ± 0.04 "
Deadband:	14 "
Dimensions:	Dia. 4.06 ", height 4.17 "
Materials:	VALOX (reg. tm of General Electric Co.)
Cable:	Shielded, oil resistant PUR insulation, length 39 ft. Can be extended to 150 ft. using MJK 690010 cable.
Enclosure:	NEMA 6P, waterproof, withstands submersion up to 30 ft.
Approvals:	FM Class 1 Division 1 Groups A-G CE EN50081-1, EN50082-1

Model 3400 Hydrostatic Level Transmitter - 1 year warranty	
Temperature range:	15 ... 160 °F
Temp. deviation, zero point:	Better than ± 0.01 % / °F
Temp. deviation, full range:	Better than ± 0.005 % / °F
Linearity / Stability:	Better than ± 0.5 % FS
Measurement accuracy:	Better than ± 0.1 % FS @ 50 to 85 °F Better than ± 0.2 % FS @ full temperature range.
Long time stability:	Better than ± 0.1 % FS per year
Material:	Housing: PPS Diaphragm: 99.9 % Al ₂ O ₃ Measurement cell packing: Viton®
Supply voltage:	10 - 30 V DC (12 - 30 V DC for cable lengths above 315 ft.)
Output:	Two-wire 4 - 20 mA (passive transmitter)
Cable:	2 × AWG 20, shielded, oil resistant PUR insulation
Cable length:	39 ft. Longer cable lengths available, consult the factory.
Enclosure:	NEMA 6P, withstands a static pressure equal to max. measuring range.
Approvals:	UL® Class 1 Division 1 Groups A-D and ATEX Ex ia IIC T6 CE EN50081-1, EN50082-1

Can be delivered with other cable lengths on request.

713 Series Open Channel Flowmeter	
Measuring ranges:	0 - 1 ft., 0 - 3 ft., 0 - 10 ft. or custom ranges
Dimensions:	Height 7.28 ", width 9.45 ", depth 4.53 "
Power supply:	110 - 120 V AC, power consumption max. 10 W
Temperature range:	- 5 to + 150 °F
Accuracy:	≤ 0.2 % of adjusted range
Materials:	Polystyrene (housing and cover)
Enclosure:	NEMA 4X
Input signal:	Either from ultrasonic sensor or from hydrostatic level transmitter
Digital outputs:	Terminal 6 - 17: relay no. 1-4, max. 250 V, max. 4 A resistive / max. 100 W inductive load. Selectable as alarm, counter, flow > 0 or sampler output. Terminal 19 - 20: Totalizer output (optocoupler), max. 36 V AC/DC, 50 mA, one shot, programmable from 100 ms to 10 s.
Analog output:	Terminal 21 - 22: (0)4-20 mA, max. 500 ohm loop resistance, galvanically isolated.
Calculation:	Standard formulas according to ASTM standards and US Department of the Interior. Optional formula Q = C × h ^X or 10 point level to flow curve linearization.
Indication calibration:	2 × 24 character backlit LCD display for reading and
Approvals:	UL-cUL listed*, file # 194021 UL 508/c22: 2 No. 142-M1987
Warranty:	1-year limited warranty

Dimensions and accessories

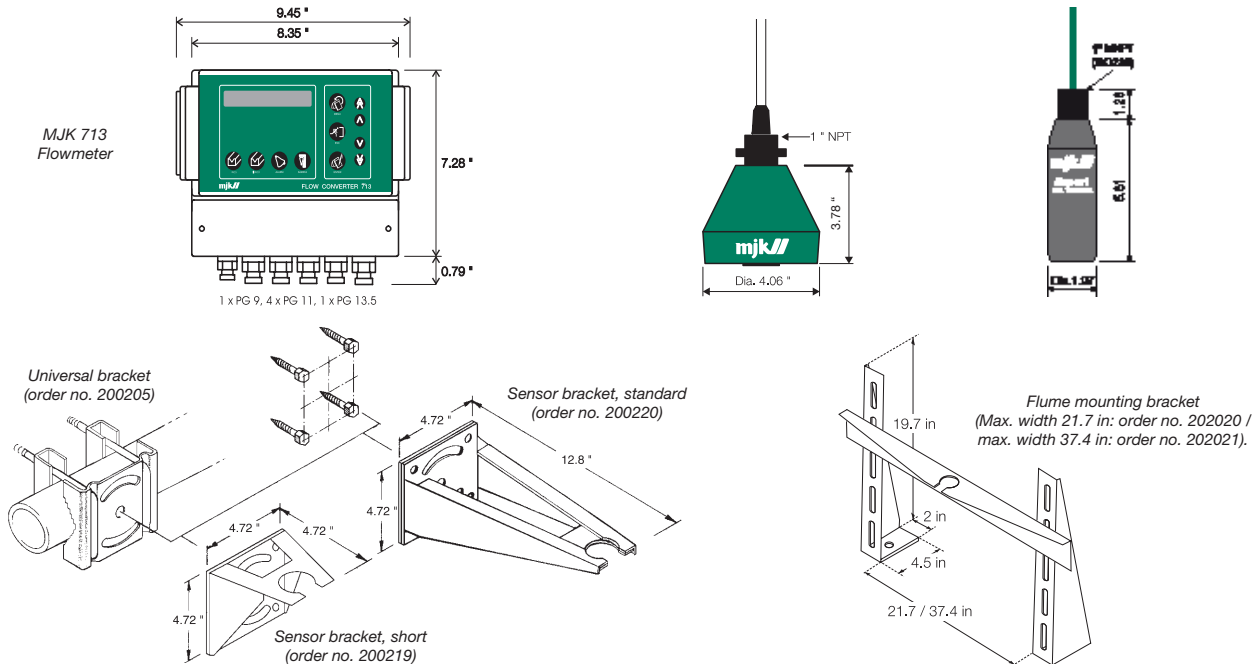

Appendix D Hardware adjustments

MJK 713 is factory adjusted to general applications. If parts are replaced or at special applications a secondary adjustment might be necessary. Below is shown which adjustments might be necessary to carry out "in field".

Ultrasonic measuring circuit

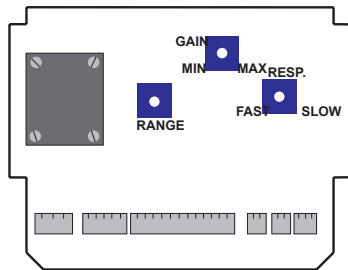

Gain:

With this potentiometer the signal strength of the received signal can be adjusted. The potentiometer is normally set in center position. At applications where there are disturbances close to the spread range of the sensor it might be necessary to reduce the signal strength. E.g. small Palmer & Bowlus flumes or when measuring is carried out through a pipe.

In other cases where e.g. the surface is unsteady or there are occurrences of foam, it might be necessary to increase the signal strength. To reduce turn counterclockwise and to increase turn clockwise.

Resp. (Response):

If the surface is very unsteady the level measuring itself can be dampened with the potentiometer.

Range:

The range of the potentiometer adjusts the level measuring itself. To carry out an adjustment, measure the distance between the 0-point and the bottom of the sensor and check the setting in menu no. 0.1.

Adjust then the current level and the range of the potentiometer is adjusted to correct display in menu no. 0.1.

The rest of the potentiometers requires special measuring equipment and should therefore only be adjusted by an authorized workshop.

Pressure measuring circuit

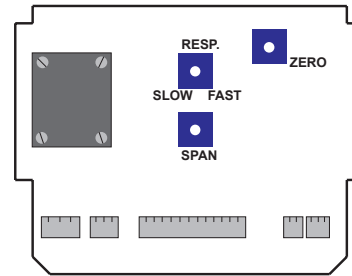

Resp. (Response):

If the surface is very unsteady the level measuring itself can be dampened with the potentiometer.

Span:

The span potentiometer is adjusted to correct level measuring at high level.

Zero:

The span potentiometer is adjusted to correct measuring at low level.

Control circuit

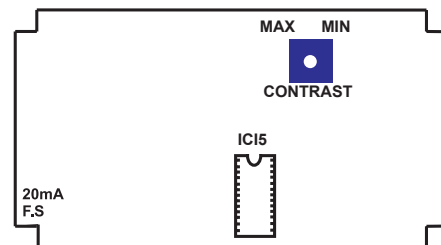

The control circuit is placed behind the front plate. The display can be adjusted satisfying display here. The contrast will automatically be adjusted according to the surrounding temperature.

Changing the EPROM:

If the MJK 713 program should be replaced you must follow these instructions:

- 1: Turn off the power.
- 2: Remove the top lid.
- 3: Remove the EPROM (ICI5).
- 4: Insert the new EPROM. The notch must face upwards as shown on the PC board. Be careful not to damage the EPROM.
- 5: Replace the top lid again and turn on the power.

Appendix E
System Package 2 - Shuttle® used as signal amplifier

To ensure a correct flow measurement when using a Shuttle® as signal amplifier, the mA signal from the Shuttle® must correspond to the selected level range on the MJK 713. Four parameters must therefore be set on the Shuttle®: the measuring unit, the zero point, the level range and the mA output zero/span.

The keyboard is used for the initial programming of the Shuttle® and is therefore hidden behind the front lid. The keys are marked with symbols indicating their function.

Display

LCD-display with symbols for indication during programming and normal service.

Keyboard

Keyboard with a brief instruction for programming the SONOLEV™.

The lower part can be tipped up to show the terminal designations.

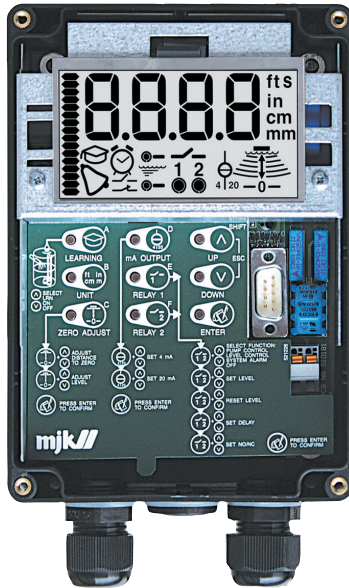

When Shuttle® is connected to the power supply for the first time, the following display will appear:



Press (ENTER) once.

At the same moment Shuttle® registers an echo, the zero point is automatically adjusted to the level that is present in the flume or weir. Furthermore, the mA output is set to 4 mA at the current zero point and 20 mA at a level corresponding to a distance of 14 in from the ultrasonic sensor.

Setting of measuring unit



The measuring unit should be set to the same unit as used on the MJK 713.

Press (UNIT) once.

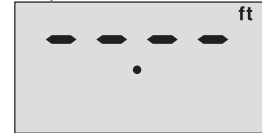

Select the measuring unit with the UP/DOWN keys and confirm with ENTER.

Setting of level readout

The level readout should be set to the actual level in the flume / weir.

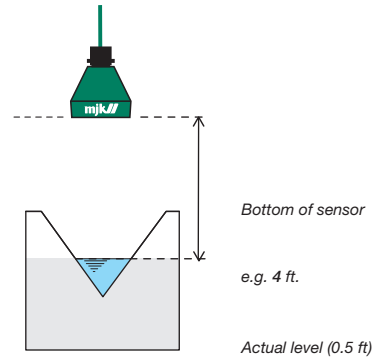

Press again.

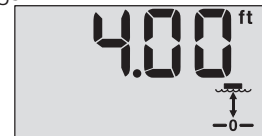

Use the UP/DOWN keys and confirm with ENTER.

Setting of zero and span for the mA output

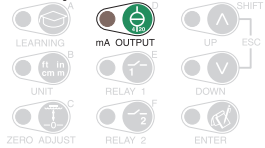

The mA output must be set to 4 mA at zero level (0.00 ft) and 20 mA at max. level (= the max. measuring range for MJK 713 - either 1 or 3 ft).

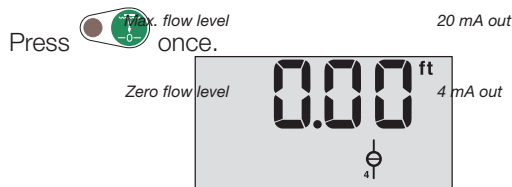
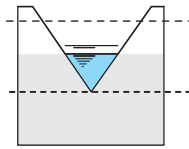

Use the UP/DOWN keys to set the zero point and confirm with ENTER.

The mA output must be set to 20 mA at max. level (1 or 3 ft).

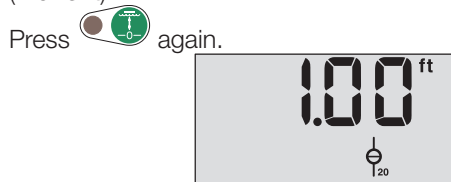

Use the UP/DOWN keys to set the span and confirm with ENTER.

Setting of relay output #1

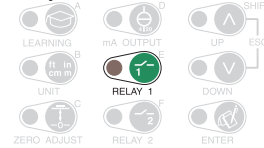

If the mA output is looped through relay 1 as shown on the connection diagram on page 14 (System Package 2), MJK 713 will indicate a system error in case of a power failure or a system error on the Shuttle®:

Press once.



Use the UP/DOWN keys to select SYSTEM ERROR function and confirm with ENTER:



Set the desired time delay for the relay:

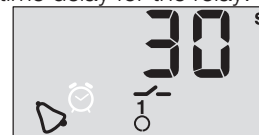

Use the arrow keys and confirm with ENTER.

Set the relay mode to 'n.c' - NORMALLY CLOSED ('n.c = normally closed):



Use the arrow keys and confirm with ENTER.

Shuttle® will now revert to normal read-out:



When the level starts to rise, Shuttle® will also indicate the level of the mA output with the bar graph. One segment is roughly 1 mA.

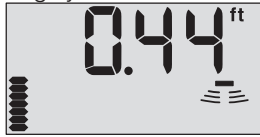

Mount the lid when all settings are made.
See also separate SONOLEV™ 3000 manual.

Note: The MJK 713 analog input must be set to 4-20 mA (factory default).

Appendix F

Max. head to max. nominal flow

Parshall flumes, 1 to 144 in

Dimension:	Max. head: [ft]	(Max. nominal flow) [CFS]
1" Parshall	0,70	0,195
2" Parshall	0,80	0,478
3" Parshall	1,10	1,15
6" Parshall	1,50	3,91
9" Parshall	2,00	8,87
12" Parshall	2,50	16,13
18" Parshall	2,50	24,56
24" Parshall	2,50	33,11
36" Parshall	2,50	50,39
48" Parshall	2,50	67,93
60" Parshall	2,50	85,62
72" Parshall	2,50	103,5
96" Parshall	2,50	139,5
120" Parshall	2,75	198,7
144" Parshall	3,50	347,0

Palmer & Bowlus flumes, 4 to 30 in

Dimension:	Max. head: [ft]	(Max. nominal flow) [CFS]
4" P&B	0,25	0,121
6" P&B	0,35	0,295
8" P&B	0,50	0,690
10" P&B	0,60	1,119
12" P&B	0,70	1,676
15" P&B	0,90	3,086
18" P&B	1,05	4,614
21" P&B	1,25	7,042
24" P&B	1,40	9,464
27" P&B	1,60	13,09
30" P&B	1,75	16,52

Rectangular weirs with side contractions

Dimension:	Max. head: [ft]	(Max. nominal flow) [CFS]
1 ft w. contraction	0,50	1,060
1½ ft w. contraction	0,75	2,920
2 ft w. contraction	1,00	5,994
2½ ft w. contraction	1,25	10,47
3 ft w. contraction	1,50	16,52
4 ft w. contraction	2,00	33,91
5 ft w. contraction	2,50	59,23
6 ft w. contraction	3,00	93,44
8 ft w. contraction	4,00	191,8
10 ft w. contraction	5,00	335,1

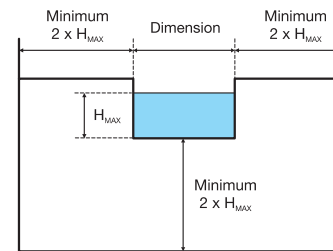

The values stated are valid only for contractions constructed with the minimum dimensions as shown in above figure.

Rectangular weirs without side contractions

Dimension:	Max. head: [ft]	(Max. nominal flow) [CFS]
1 ft wo. contraction	0,50	1,177
1½ ft wo. contraction	0,75	3,244
2 ft wo. contraction	1,00	6,660
2½ ft wo. contraction	1,25	11,63
3 ft wo. contraction	1,50	18,35
4 ft wo. contraction	2,00	37,67
5 ft wo. contraction	2,50	65,81
6 ft wo. contraction	3,00	103,8
8 ft wo. contraction	4,00	213,1
10 ft wo. contraction	5,00	372,3

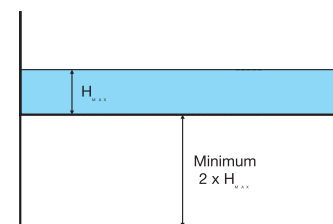

The values stated are valid only for contractions constructed with the minimum dimensions as shown in above figure.

V-notch weirs

<i>Dimension:</i>	<i>Max. head:</i> <i>[ft]</i>	<i>(Max. nominal flow)</i> <i>[CFS]</i>
22,5° V-notch	2,00	2,811
30° V-notch	2,00	3,824
45° V-notch	2,00	5,855
60° V-notch	2,00	8,163
90° V-notch	2,00	14,14
120° V-notch	2,00	24,49

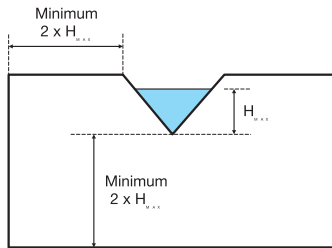

The values stated are valid only for contractions constructed with the minimum dimensions as shown in above figure.

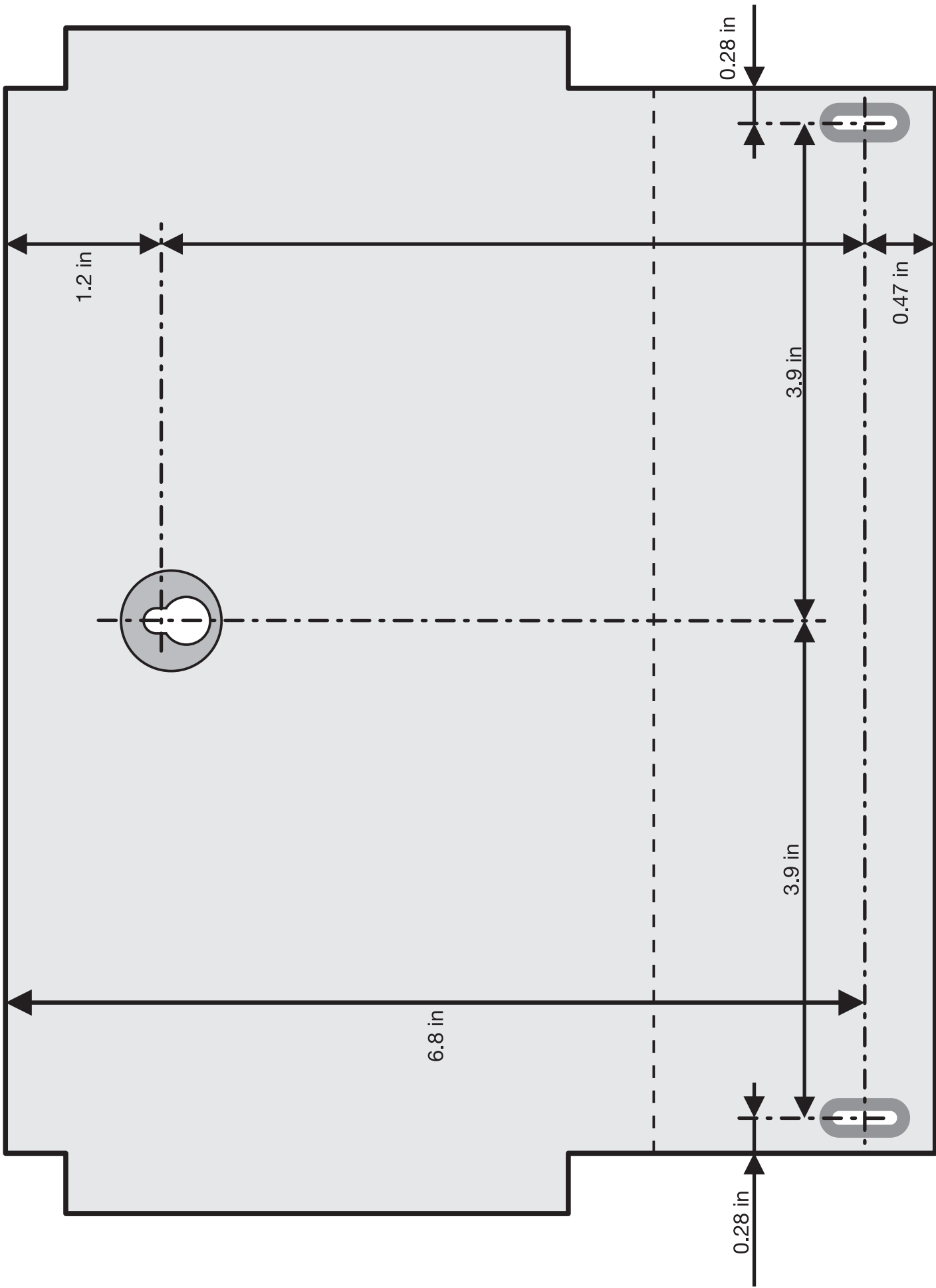

Liability

MJK Automation A/S are liable to the common rules of Danish law on product liability, however, the liability is reduced to coverage of our public liability insurance of products. To the extent where nothing else follows in lines of invariable rules of law, we are not liable for loss of profits and working deficits or other indirect losses.

Changes

As our products are developed continuously, we reserve the right to make any alterations without prior notice.