

248 All Stainless Steel Redi-Clamp

1/2" - 2" Nominal O.D.

Product Specifications

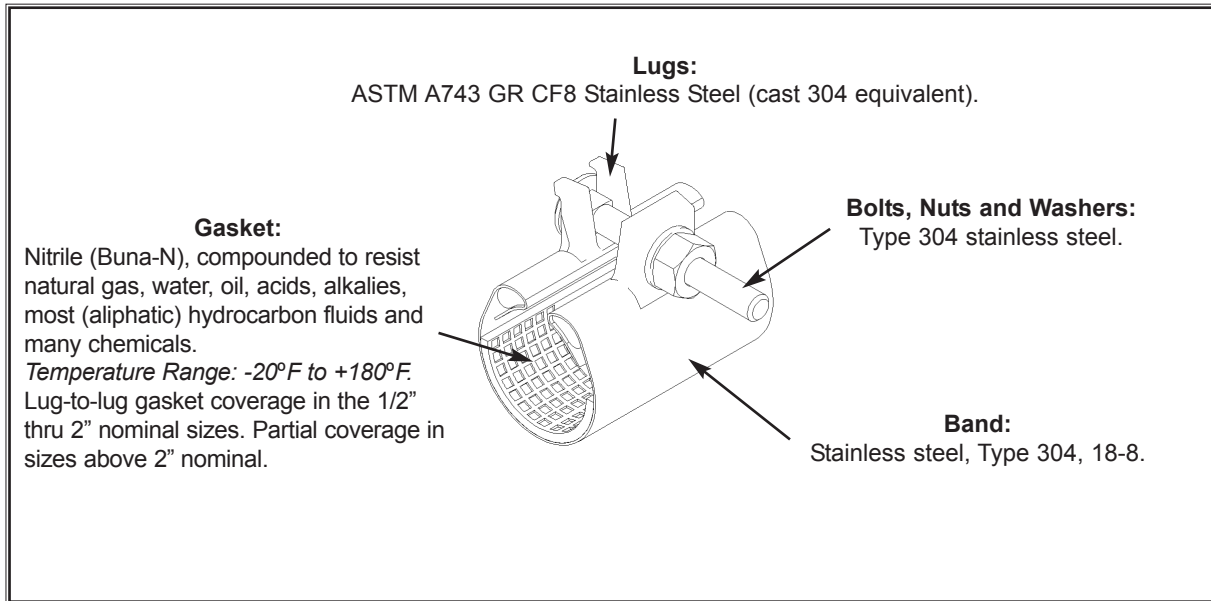

Features:

- Certified to NSF®/ANSI 61-G.
- Built to a specific pipe O.D.
- Drop-in bolts help ease installation.
- Available in 1/8" or 1/4" thick gasket material.
- Available in smooth or gridded gasket material.
- Standard widths 3", 6", 9" and 12", other widths available.
- All 304 stainless steel metal components for great corrosion resistance.
- Economical means of repairing pin hole leaks, punctures and splits in pipe.
- Always available with lug-to-lug gasket in the 1/2" to 2" O.D.'s; optional in larger sizes.

Clamp Number	Size	Working Pressure*
248	1/2"-2" Nominal	Up to 250 PSI

*The allowable working pressure of a pipe repair clamp decreases as pipe diameter increases (regardless of manufacturer). For a particular installation, the allowable working pressure will be determined by the size of pipe, type of pipe, type of clamp, type and extent of damage, service conditions, environmental conditions, and installation workmanship.

Product Specifications

SPECIFICATION:

The 248 All Stainless Steel Redi-clamp shall have an 18-8 type 304 stainless steel band.

The band shall be a minimum of 3" in width. The lugs shall be made of ASTM A743 GRCF8 stainless steel (cast 304 equivalent). The 248 lugs shall be attached to the band by wrapping the end of the band around the lug base.

The gasket shall be made of Nitrile

(Buna N) specially compounded to resist water, oil, acids, alkalies, natural gas, most (aliphatic) hydrocarbon fluids, and many other chemicals. The temperature range of the gasket shall be -20°F thru +180°F. The gasket shall have a gridded pattern (or smooth) and be 1/8" (or 1/4") thick.

The nuts, bolts and washers shall be 304 stainless steel. The nuts shall be fluo-polymer coated to prevent galling.

The clamp shall be a Smith-Blair, Inc., 248 All-Stainless Steel Redi-Clamp or approved equal.

Approved By

Name:

Title:

Date:

THESE PRODUCT SPECIFICATIONS WERE CORRECT AT TIME OF PUBLICATION.

MATERIAL SPECIFICATIONS ARE SUBJECT TO CHANGE WITHOUT NOTICE.

SEE CATALOG BROCHURE CC-240 FOR MORE DETAILS. VISIT SMITH-BLAIR'S WEBSITE AT WWW.SMITH-BLAIR.COM TO DOWNLOAD THE MOST CURRENT INFORMATION.



Ph: 870-773-5127 • Fax: 870-773-5212 • www.smith-blair.com

Toll-Free Numbers: Ph: 800-643-9705 • Fax: 800-648-6792

30 Globe Ave, Texarkana, AR 71854 • PO Box 5337, Texarkana, TX 75505