



Smith-Blair
a xylem brand

SPECIFICATION

ALL STAINLESS STEEL TAPPING SLEEVE

MODEL 663WR

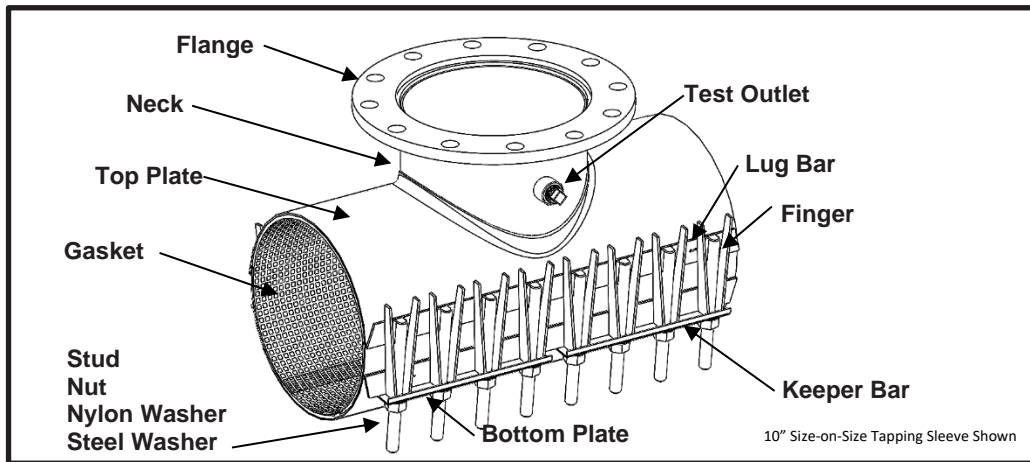

APPLICATIONS

- **Typical Uses**
 - Tapping size-on-size branch connections on new or existing pipe
 - Tapping reducing branch connections on new or existing pipe
 - Installing valves and other miscellaneous service equipment
 - Typically utilized where a 360° seal is needed for support and reinforcement of the pipe in case of pipe break
 - Wider Range for tapping applications where pipe O.D. is in question
- **Standard Pipe Sizes**
 - 4" to 12" nominal
- **Outlet Type and Size**
 - 4" to 12"
- **Type of Pipe (see notes)**
 - Carbon Steel, Stainless Steel, Cast Iron, Asbestos Cement, PVC, HDPE, Ductile Iron
- **Working Pressure / Test Pressure (see notes)**
 - 240 psi / 300 psi

MATERIALS

- **Top Plate**
 - Type 304 Stainless Steel per ASTM A240
 - Material thickness: 12 gauge for all nominal pipe sizes
- **Bottom Plate**
 - Type 304 Stainless Steel per ASTM A240
 - Material thickness: 16 gauge for all nominal pipe sizes
- **Neck**
 - Type 304 Stainless Steel per ASTM A240 or ASTM A312
 - Furnished with 3/4" NPT test outlet
 - Accepts full size cutters except size-on-size taps
 - For size-on-size applications on I.P.S. size pipe, Smith-Blair recommends a minimum of 1/2" smaller cutter. Example, for a 12" outlet on 12.75" pipe use an 11.5" cutter. Also, do not exceed the maximum cutter size your pipe manufacturer recommends for any given pipe diameter and SDR.



Smith-Blair
a xylem brand

SPECIFICATION

ALL STAINLESS STEEL TAPPING SLEEVE

MODEL 663WR

- **Flange**
 - Type 304 Stainless Steel per ASTM A240
 - Steel ring flat face
 - Compatible with ANSI 125# and 150# bolt hole patterns
 - Recessed for tapping valve alignment per MSS SP-60
- **Finger**
 - Type 304 Stainless Steel per ASTM A240
 - Finger Thickness: 10 gauge
- **Lug Bar**
 - Type 304 Stainless Steel per ASTM A240
 - Lug Bar Thickness: 10 gauge
- **Keeper Bar**
 - Type 304 Stainless Steel per ASTM A240
 - Keeper Bar Thickness: 14 gauge
- **Gasket**
 - Nitrile (Buna-N) per ASTM D2000
 - Gasket Thickness: 0.250"
 - Compounded to resist water, oil, natural gas, acids, alkalies, most (aliphatic) hydrocarbon fluids, and many other chemicals
 - Temperature range: -20°F to +180°F
 - Gridded face gaskets with tapered ends
 - Molded-in ring into gasket for neck seal
- **Bridge Plate**
 - Type 304 Stainless Steel quarter hard per ASTM A240
 - Molded and recessed into upper body gasket
- **Stud**
 - Type 304 Stainless Steel per ASTM A276
 - Epoxy coated threads
 - 5/8"-11UNC x 8.50, Stud with Rolled Threads
- **Nut**
 - Type 304 Stainless Steel GR. 8 per ASTM A194
 - Fluoropolymer coated
 - 5/8"-11UNC, Heavy Hex Semi-Finished
- **Steel Washer**
 - Type 304 Stainless Steel per ASTM A240
 - 5/8" Type A Plain
- **Nylon Washer**
 - Nylon 6/6
 - 5/8" diameter
- **Test Outlet**
 - Type 304SS 3/4" FNPT half coupling per ASTM A276
 - Lead Free Bronze 3/4" MNPT square head test plug per ASTM B584
- **Welding**
 - Welds accomplished using qualified welders
 - GMAW weld process utilized
 - Welds passivated to preserve corrosion resistance



Smith-Blair
a xylem brand

SPECIFICATION

ALL STAINLESS STEEL TAPPING SLEEVE

MODEL 663WR

LISTINGS/STANDARDS

- Certified to NSF/ANSI 61 and NSF/ANSI 372
- Meets applicable portions AWWA C223

OPTIONS

- Angled (Wye) pattern configuration
- Alternative gasket material (e.g. Viton, EPDM, etc.)
- Anode connector
- Threaded outlet 3/4" to 6" NPT
- MJ outlet 4" to 12"
- Line Stop outlet
- 411 style coupling outlet
- Any industry standard flange
- Stainless Steel test plug
- Custom neck length

NOTES

- Xylem, Smith-Blair, and SB stylized are registered trademarks of Xylem, Inc., or one of its subsidiaries.
- These product specifications were correct at the time of publication and are subject to change without notice
- See the Smith-Blair website for part numbers and ordering information
- See the Smith-Blair website for warranty information
- See the Smith-Blair website for corrosion notice
- The working pressure of a tapping sleeve decreases as pipe diameter increases (regardless of manufacturer). For a particular installation, the allowable working pressure will be determined by the size of pipe, type of pipe, type of clamp, type and extent of damage, service conditions, environmental conditions, and installation workmanship.
- Smith-Blair has the following recommendations for using its tapping sleeves on HDPE pipe.
 1. Due to the relaxation of the HDPE pipe when cut, a cutter of 2" smaller than the nominal outlet size should be used.
 2. To support the tapping sleeve gasket on the tangent line, a hole not larger than 2/3 the pipe outside diameter should be used.
 3. To reduce the thermal elongation of the piping and its associated chaffing of the tapping sleeve gasket, only underground applications should be used.
 4. The tapping sleeve gasket requires pipe support to seal, therefore pipe wall thickness of SDR 17 or greater is suggested.
 5. The operating pressure shall not exceed the pressure rating of the pipe or the maximum pressure rating of the fitting; whichever is less.
 6. The piping systems should be designed to compensate for pipe movement to prevent the fittings from moving or rotating on the pipe.
 7. Consult the HDPE pipe manufacturer concerning the long term suitability of mechanical type sealing fittings over the lifetime of their HDPE pipe.
- Use of this fitting on PVC pipe is limited to wall thicknesses DR 25 or thicker. Consult the PVC pipe manufacturer concerning the long term suitability of mechanical type sealing fittings over the lifetime of their PVC pipe.

30 Globe Ave, Texarkana, AR 71854
Ph: 870-773-5127 • Fax: 870-773-5212
Toll-Free Numbers: Ph: 800-643-9705 • Fax: 800-648-6792

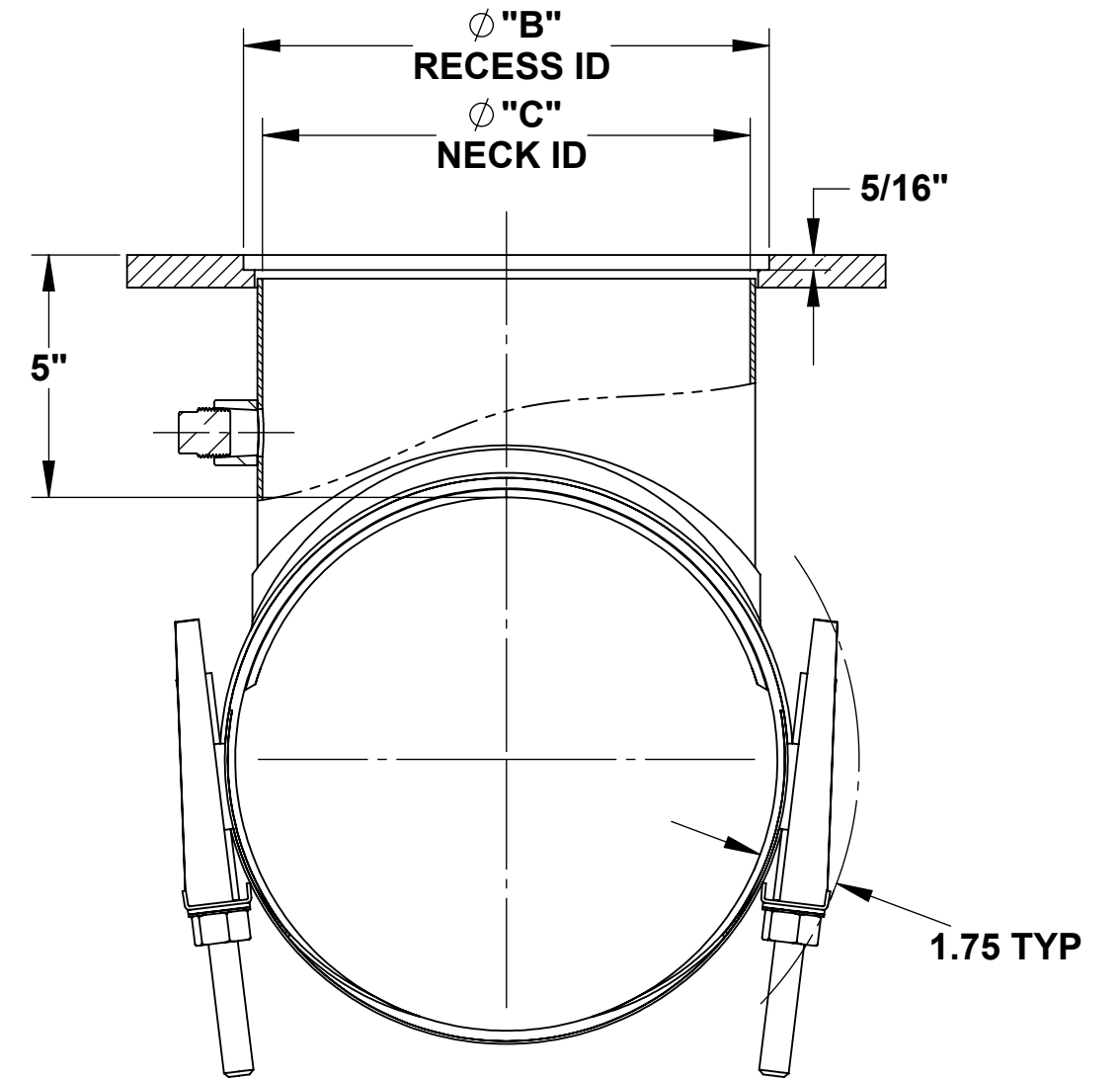
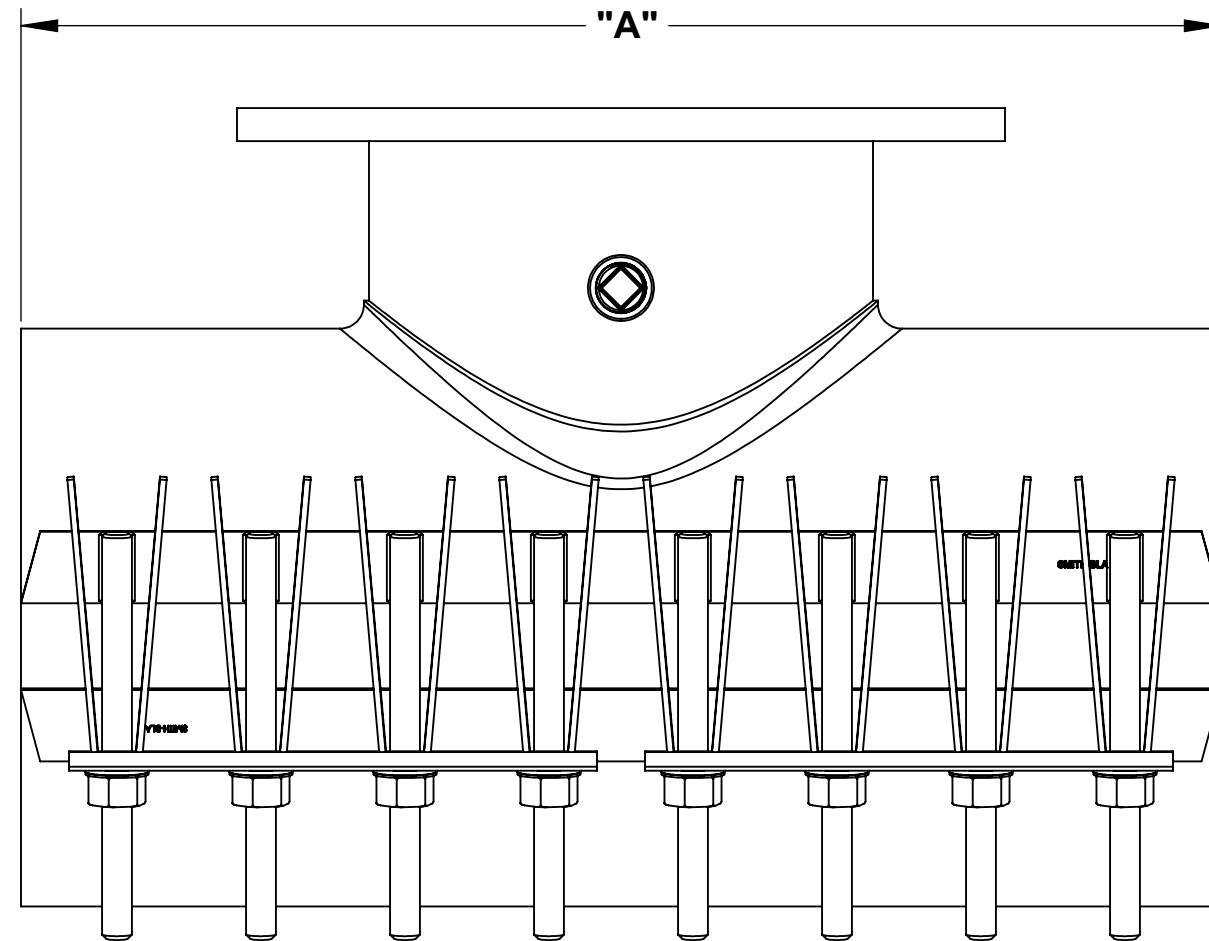

- NOTES:**
1. SEE SMITH-BLAIR CATALOG FOR SIZES NOT SHOWN
 2. 10" SIZE-ON-SIZE TAPPING SLEEVE SHOWN OTHER SIZES SIMILAR
 3. FLANGE RECESS MEETS MSS SP-60 SPECIFICATIONS

OUTLET SIZE	NOMINAL PIPE SIZE	(O.A.L.) A	B	C	BOLT QTY.
4	4-12	15	5.06	4.29	8
6	6-12	15	7.06	6.36	8
8	8-12	20	9.06	8.33	10
10	10	25	11.09	10.25	16
	12	25		10.42	
12	12	25	13.09	12.25	16

WRENCH SIZE CHART

5/8"-11UNC HH NUT	1-1/16"
3/4" SQ. PLUG	5/8"

TOLERANCES U.N.O. .XX= ±.03 .XXX= ±.015 FRACTIONS= ±1° MACH. FIN=	NOTES: REMOVE BURRS AND SHARP EDGES DO NOT SCALE DWG.	APP'D	DATE
	SCALE: N/A	CK'D	DATE
ALL DIMENSIONS ARE IN INCHES.	DRN	SPW	DATE 11/3/23
TITLE SPECIFICATION AII STAINLESS STEEL TAPPING SLEEVE MODEL 663WR			
SMITH-BLAIR TEXARKANA, ARKANSAS	P/N	N/A	
	DWG. NO.	4 OF 4 SHEET	11/3/23 REV.