

SPECIFICATION

FLANGE-LOCK™ RESTRAINED FCA

MODEL 920

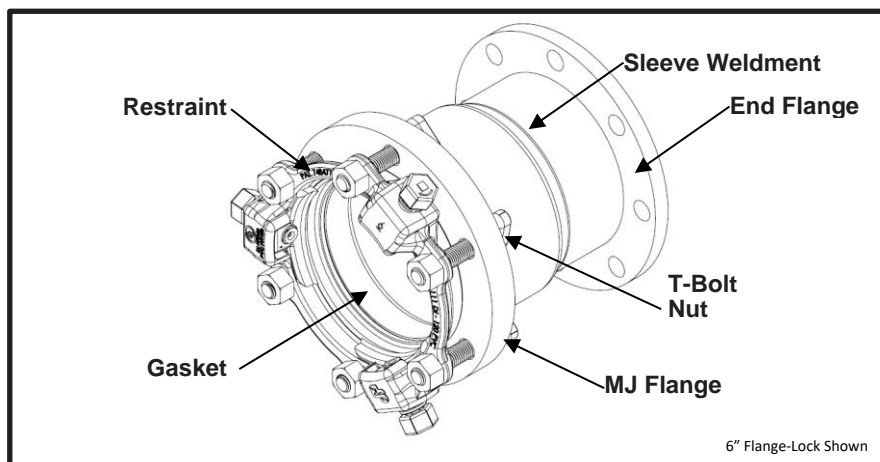

APPLICATIONS

- **Typical Uses**
 - Joining and restraining plain-end PVC pipe ends to flanged pipe, fittings, valves, meters, or other flanged equipment
- **Standard Pipe Size**
 - DI sized 3" - 36" nominal
 - IPS sized 3" - 12" nominal
- **Type of Pipe**
 - PVC
- **Working Pressure** (*see options for higher working pressure design*)
 - 3" – 12" nominal pipe size = 175 psi
 - 14" – 30" nominal pipe size = 150 psi
 - 36" nominal pipe size = 125 psi

MATERIALS

- **Sleeve Weldment**
 - See 923 specification document
- **Restraint**
 - See 120 specification document
- **Gasket**
 - Styrene Butadiene Rubber (SBR) per ASTM D2000
 - Compounded to resist water, oil, natural gas, acids, alkalies, most (aliphatic) hydrocarbon fluids, and many other chemicals
 - Temperature range: -20°F to +180°F
 - Permanently marked with part number and pipe size range for proper selection
 - Sized in accordance with AWWA C111/A21.11
- **T-Bolt**
 - HSLA Carbon Steel per AWWA C111/A21.11
 - 3/4" – 10 UNC
 - Rolled threads for improved physical characteristics, greater thread accuracy, and smooth surface finish



Smith-Blair
a xylem brand

SPECIFICATION

FLANGE-LOCK™ RESTRAINED FCA

MODEL 920

- Nut
 - HSLA Carbon Steel per AWWA C111/A21.11
 - 3/4" – 10 UNC, Heavy Hex Semi-Finished

LISTINGS

- Certified to NSF/ANSI 61 and NSF/ANSI 372
- Meets applicable portions of AWWA C219
- Flexi-Coat® Fusion-Bonded Epoxy Coating meets requirements of AWWA C213

OPTIONS

- Other materials of construction (e.g. 304SS, 316SS, etc.)
- Type 304 Stainless Steel hardware with fluoropolymer coated nuts to prevent galling
- Type 316 Stainless Steel hardware with fluoropolymer coated nuts to prevent galling
- Multi-Seal Gasket 4" - 12"
- Alternative gasket material (e.g. Buna-N, EPDM, etc.)
- Anode Connector
- Pipe stop incorporated into sleeve
- Custom sleeve length and thickness
- High pressure flange types
- Any industry standard flange

NOTES

- These product specifications were correct at the time of publication and are subject to change without notice
- Flexi-Coat® is a registered trademark of Smith-Blair Inc.
- Flange-Lock™ is a trademark of Smith-Blair Inc.
- See the Smith-Blair web site for part numbers and ordering information
- See the Smith-Blair web site for warranty information
- See the Smith-Blair web site for corrosion notice

30 Globe Ave, Texarkana, AR 71854
Ph: 870-773-5127 • Fax: 870-773-5212
Toll-Free Numbers: Ph: 800-643-9705 • Fax: 800-648-6792

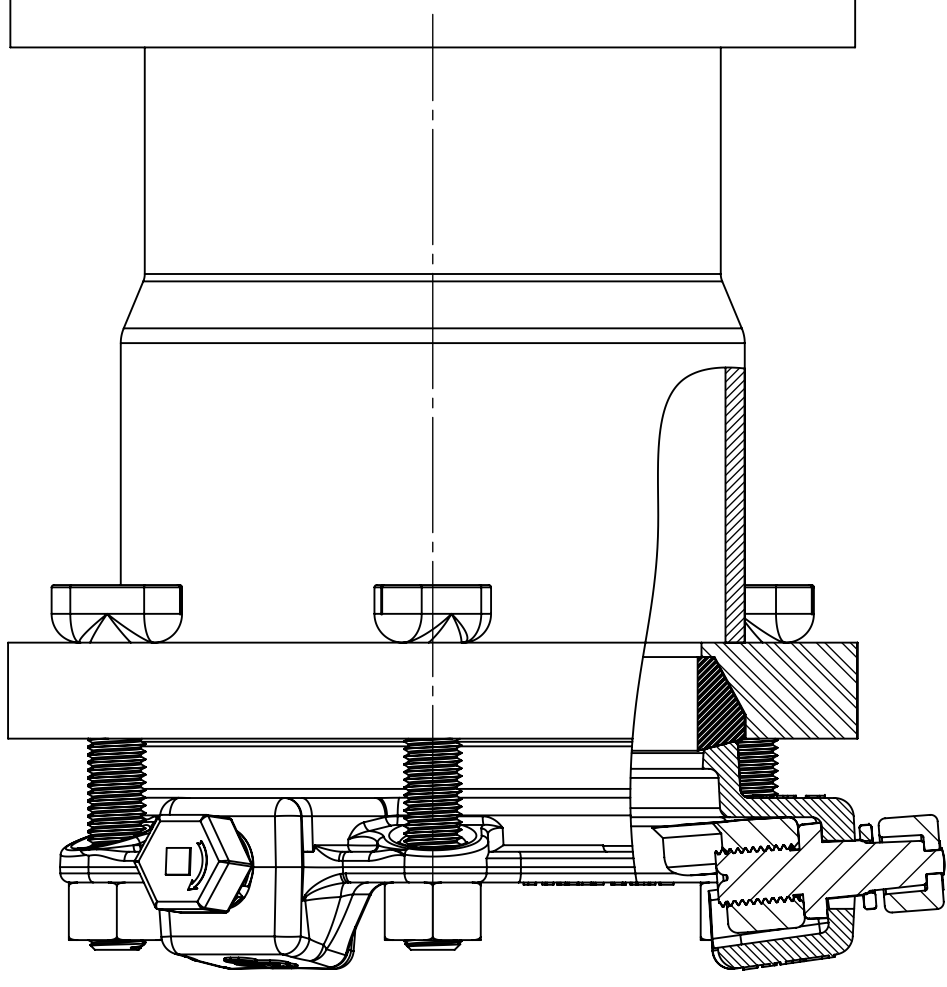
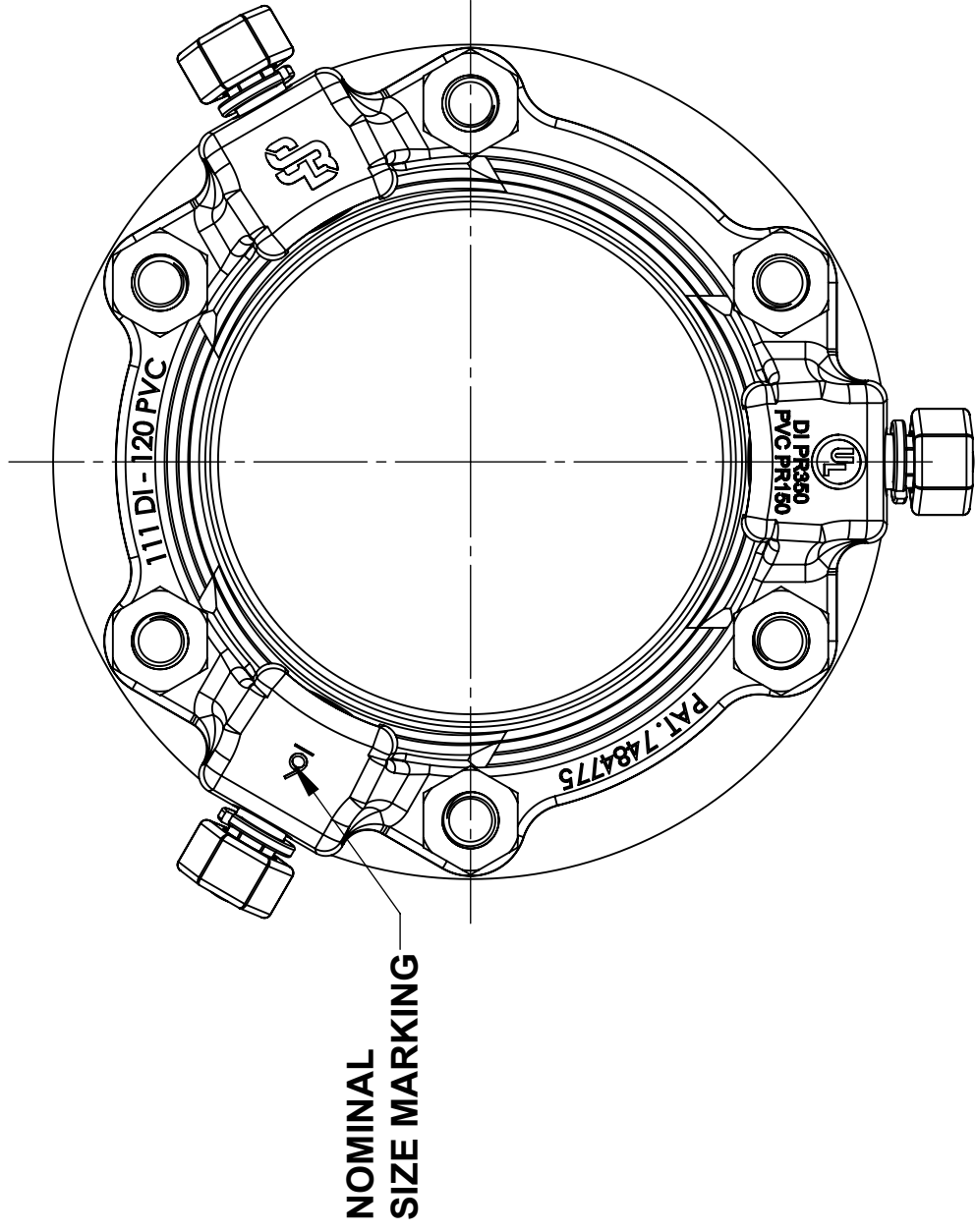

NOTES:

1. SEE SMITH-BLAIR CATALOG FOR ADDITIONAL DETAILS
2. 6" FCA SHOWN OTHER SIZES SIMILAR
4. SEE MODEL 923 AND 120 SPECIFICATIONS FOR ADDITIONAL DETAILS

TOLERANCES U.N.O. XX= ±.03 XXX= ±.015 FRACTIONS= * ANGLES= ±1° MACH. FIN=	NOTES: REMOVE BURRS AND SHARP EDGES DO NOT SCALE DWG.	APP'D	DATE
	SCALE: N/A	CK'D	DATE
	ALL DIMENSIONS ARE IN INCHES.	DRN	DATE
TITLE		CHD	10/19/15
SPECIFICATION			
FLANGE-LOCK™ RESTRAINED FCA			
MODEL 920			
P/N		N/A	
SMITH-BLAIR, Inc.		SPEC_920.DRW	
TEXARKANA, ARKANSAS		DWG. NO.	
		1 OF 1 SHEET	
		8/6/20 REV.	