

Functional description

photoLab[®] 6600 UV-VIS

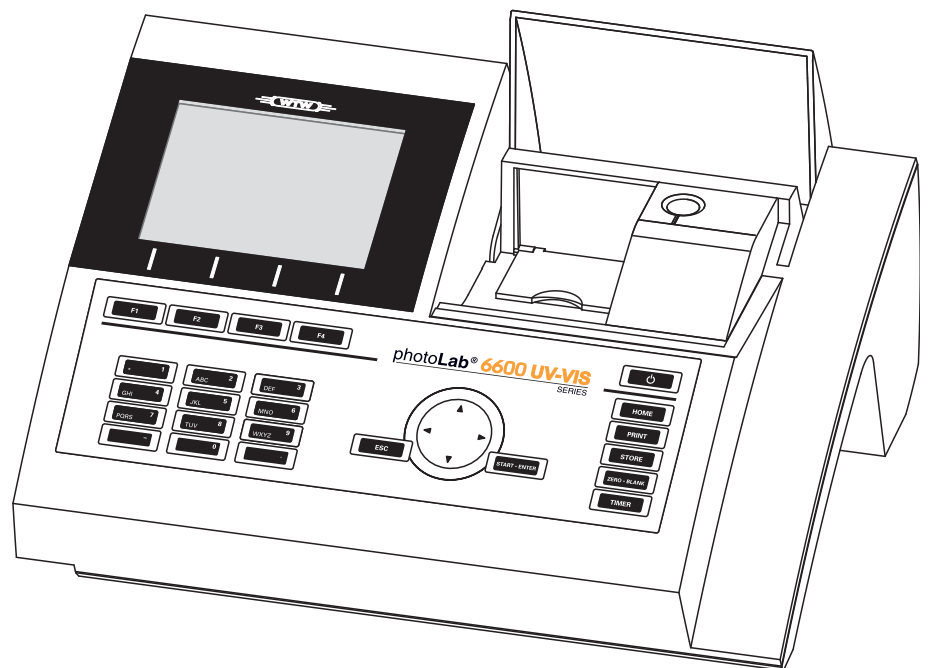

Spectrophotometer

**Accuracy when going to
press**

The use of advanced technology and the high quality standard of our instruments are the result of continuous development. This may result in differences between this operating manual and your instrument. Also, we cannot guarantee that there are absolutely no errors in this manual. Therefore, we are sure you will understand that we cannot accept any legal claims resulting from the data, figures or descriptions.



Note

The latest version of the present operating manual is available on the Internet under <http://www.WTW.com>.

Copyright

© Weilheim 2009, WTW GmbH
Reprinting - even as excerpts - is only allowed with the explicit written authorization of WTW GmbH.
Printed in Germany.

photoLab® 6600 UV-VIS - Contents

1	Overview	7
1.1	Overview of the instrument	7
1.2	Keypad	8
1.3	Display	10
2	Safety instructions	11
2.1	Target group and user qualification	11
2.2	Authorized use	12
2.3	General safety instructions	12
2.4	Handling of hazardous substances	13
3	Commissioning	15
3.1	Scope of delivery	15
3.2	Initial commissioning	15
3.2.1	Inserting the buffer batteries	16
3.2.2	Connecting the power supply	17
3.2.3	Switching on the photometer for the first time	18
3.2.4	Setting the language	18
3.2.5	Setting the date and time	19
3.3	Connecting optional accessories	20
3.3.1	Communication interfaces	20
3.3.2	PC/printer	21
3.3.3	USB memory device	22
3.3.4	PC keyboard	22
3.3.5	Barcode reader	23
3.3.6	Car Adapter photoLab® 6xxx	23
4	Operation	25
4.1	Switching on or off the photometer	25
4.2	General operating principles	28
4.2.1	Navigating with function keys and menus	28
4.2.2	Display of navigation paths in short form	30
4.2.3	Entry of numerals, letters and characters	31
4.2.4	Detailed operating example: Changing the language	33
4.3	Photometer settings and system administration	34
4.3.1	Language	34
4.3.2	Date/Time	35
4.3.3	Display settings	36

4.4	Zero adjustment	37
4.5	Measuring in <i>Concentration</i> mode	41
4.5.1	Measuring cell tests with barcode	41
4.5.2	Measuring reagent tests with AutoSelector	42
4.5.3	Measuring reagent-free tests and user-defined methods	44
4.5.4	Exceeding the upper or lower limits of the measuring range	46
4.5.5	Selecting a method manually	47
4.5.6	Settings for <i>Concentration</i> mode	48
4.5.7	Measuring diluted samples	50
4.5.8	Sample blank value	52
4.5.9	Reagent blank value	54
4.5.10	Automatic Turbidity correction	58
4.5.11	Programming / modifying user-defined methods	58
4.5.12	The <i>IQ LabLink</i> procedure	68
4.6	Measuring the Absorbance / % Transmission	69
4.6.1	General information	69
4.6.2	Measuring the absorbance or transmission	69
4.6.3	Measuring against the Reference absorbance	71
4.7	Multi wavelengths methods	73
4.7.1	Basic information on Multi wavelengths measurements	73
4.7.2	Programming / modifying Multi wavelengths methods	74
4.7.3	Selecting a Multi wavelengths method	77
4.7.4	Carrying out Multi wavelengths measurements	78
4.8	Spectrum	80
4.8.1	General information	80
4.8.2	Recording the Spectrum	81
4.8.3	Loading/editing a spectrum	84
4.8.4	Saving / exporting a spectrum	87
4.9	Kinetics	88
4.9.1	Creating/editing profiles for kinetic records	88
4.9.2	Loading a profile for kinetic recording	91
4.9.3	Recording the Kinetics	92
4.9.4	Saving / exporting a kinetic record	95
4.9.5	Loading a kinetic record	96
4.9.6	Editing a kinetic record	97
4.10	Timer	99
4.10.1	<i>User defined timer</i>	100

4.10.2	Analysis timer	100
4.11	Memory	102
4.11.1	Overview	102
4.11.2	Instructions on using USB memory devices	104
4.11.3	Measurement datasets	105
4.11.4	Saving measurement datasets manually	105
4.11.5	Saving measurement datasets automatically	106
4.11.6	Displaying measurement data memory	107
4.11.7	Filtering measurement datasets	109
4.11.8	Inverting filters	110
4.11.9	Erasing stored measurement datasets	111
4.12	Copying files	112
4.12.1	Copying individual files to a USB memory device	112
4.12.2	Copying all measurement data files to a USB memory device	114
4.12.3	Copying files to a PC	115
4.13	Transmitting data	116
4.13.1	Printer and terminal programs	116
4.13.2	Settings for data transmission	116
4.13.3	Printing measurement datasets	117
4.13.4	Printing Kinetics records	118
4.13.5	Printing spectra	119
4.14	Analytical quality assurance (AQA)	120
4.14.1	General information	120
4.14.2	Photometer monitoring (AQA1)	121
4.14.3	Total system monitoring (AQA2)	126
4.14.4	AQA3/MatrixCheck	130
4.15	User management	136
4.15.1	User levels and user rights	136
4.15.2	Activating or deactivating the User management function	137
4.15.3	Creating, changing or deleting a user account	138
4.15.4	Login with active user management	141
4.15.5	Changing the password	143
4.16	Reset	144
4.17	Photometer information ([Info])	145
4.18	Lamp counter	145
4.19	Software and methods update	146
4.19.1	Update by means of a USB memory device	146
4.19.2	Update by means of a PC	148
4.19.3	Software update "Chinese character set"	149

5	Maintenance and cleaning	151
5.1	Exchanging the buffer batteries	151
5.2	Cleaning	152
6	What to do if	153
6.1	Actions in the case of a broken cell	153
6.2	Error causes and remedies	154
7	Technical data	157
7.1	Measurement characteristics	157
7.2	Measured value documentation and quality assurance	160
7.3	General meter data	161
8	Accessories and options	163
8.1	Accessories	163
8.2	Test equipment	164
8.3	Optional equipment	164
8.4	Connection cable:	165
	Appendix	167
A.1	Menus	167
A.1.1	Measuring	167
A.1.2	General settings and functions	171
A.2	Glossary	175
A.3	List of trademarks	177
3.1	Index	179

1 Overview

1.1 Overview of the instrument

Front of the instrument

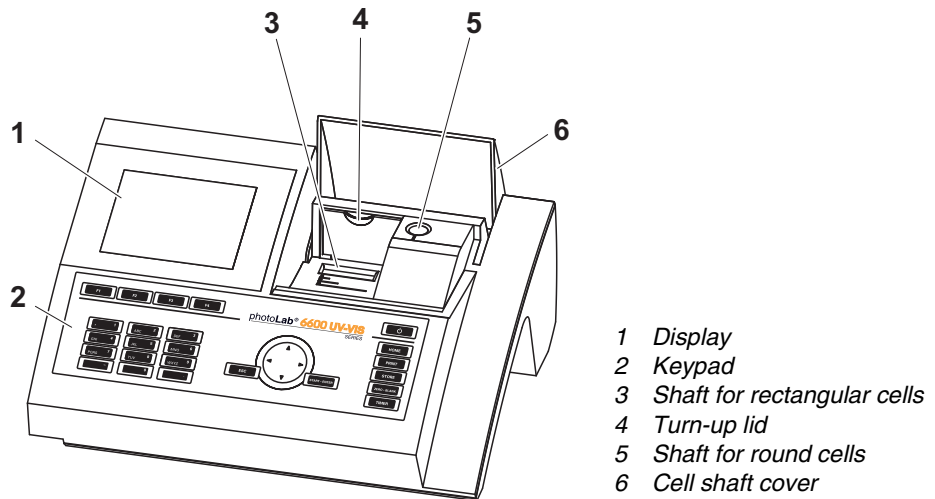

Fig. 1-1 Front of the instrument with operating elements

Socket field on the rear panel

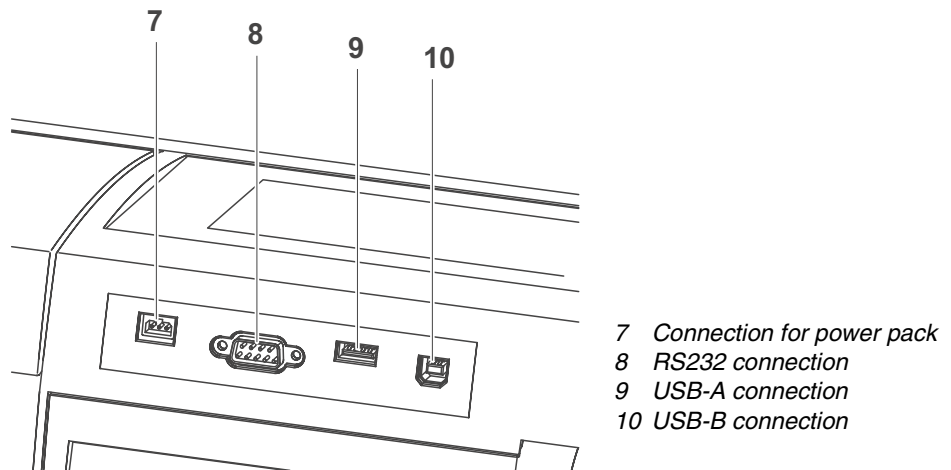

Fig. 1-2 Rear panel with socket field



Note

All connections comply with SELV.

1.2 Keypad

Overview

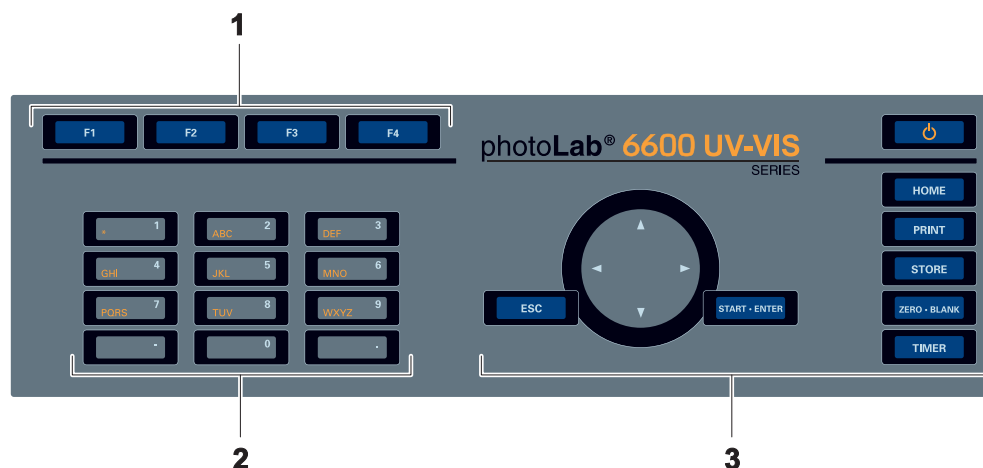









- 1 Function keys F1 to F4 (function menu-dependent)
- 2 Alphanumeric keypad
- 3 Keys with dedicated function

Fig. 1-3 Keypad

Key functions

The keys on the right side of the keypad have the following functions:

Key	Designation	Functions
	<ON/OFF>	– Switches on and off the photometer.
	<HOME>	– Switches to the main menu from any operating situation. Actions that are not completed are canceled.
	<PRINT>	– Downloads the displayed measured value to an interface if the <i>Printer</i> symbol is displayed in the status line.
	<STORE>	– Saves a displayed measured value or spectrum if the <i>Save</i> symbol is displayed in the status line.
	<ZERO · BLANK>	– Starts one of the following measurements, depending on the operating situation: - Zero adjustment - Blank value measurement - Baseline measurement.

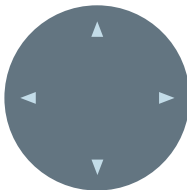
Key	Designation	Functions
	<TIMER>	– Opens the menu, <i>Timer</i> .
	<ESC>	– Cancels the running action. Entries that have not yet been accepted are discarded. – Switches to the next higher menu level.
	<START·ENTER>	– Starts an action (e.g. measurement) – Opens a selected menu – Confirms a selection or entry
 (Arrow keys)	<▲>or <▼>	– Moves the selection in menus and lists one position up or down
	<◀>	– Deletes the character left of the cursor during character entries – Moves the cursor to the left in a spectrum or kinetic diagram
	<▶>	– Moves the cursor to the right in a spectrum or kinetic diagram

Function keys

The function keys F1 to F4 have different functions depending on the operating situation. The current functions are displayed in the function key menu at the bottom edge of the display (see section 4.2.1).

1.3 Display

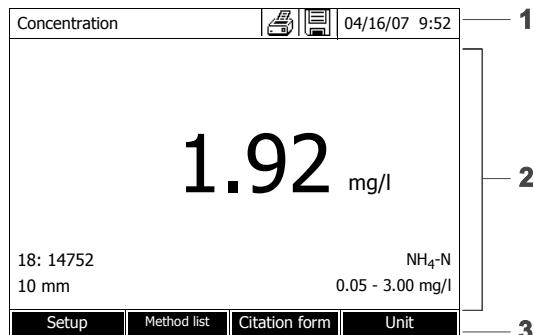

Display elements



- 1 Status line (current state, date and time)
- 2 Display range for menus and measurement results
- 3 Function keys menu

Bild 1-4 Display

Symbols in the status line

Symbol	Designation	Function
	Save	The <STORE> key is active. You can store the displayed data with <STORE> (see section 4.11).
	Printer	The <PRINT> key is active. You can output to an interface the displayed data with <PRINT> (see section 4.13).
	Progress bar	During the warm-up time (15 minutes) a progress bar appears on the display. The reproducibility of measured values is limited during the warm-up time (see section 4.13).

2 Safety instructions

This operating manual contains basic instructions that you must follow during the commissioning, operation and maintenance of the photometer. Consequently, all responsible personnel must read this operating manual carefully before working with the meter. Keep this operating manual in the vicinity of the meter.

General safety instructions

Safety instructions in this operating manual are indicated by the warning symbol (triangle) in the left column. The signal word (such as "caution") indicates the danger level:



Warning

indicates instructions that must be followed precisely in order to prevent serious dangers to personnel.



Caution

indicates instructions that must be followed precisely in order to avoid slight injuries to personnel or damage to the instrument or the environment.

Other labels



Note

indicates notes that draw your attention to special features.

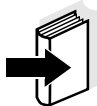

Note

indicates cross-references to other documents.

2.1 Target group and user qualification

The photometer was developed for use in the laboratory. Carrying out photometric determinations with the aid of test sets frequently requires the handling of hazardous substances.

We assume that the operating personnel know how to handle hazardous substances due to their professional training and experience. The operating personnel must particularly be able to understand and correctly implement the safety labels and safety instructions on the packages and inserts of the test sets.

2.2 Authorized use

The authorized use of the photometer consists exclusively of the carrying out of photometric measurements according to this operating manual. Follow the technical specifications of the cells in chapter 7 TECHNICAL DATA. Any other use is considered to be **unauthorized**.

2.3 General safety instructions

The photometer is built and inspected according to the relevant guidelines and norms for electronic instruments (see chapter 7 TECHNICAL DATA). It left the factory in a safe and secure technical condition.



Note

Opening the photometer or adjustment and repair work must only be performed by specialist personnel authorized by the manufacturer. Noncompliance invalidates any claim with regard to the warranty.

Function and operational safety

The smooth functioning and operational safety of the photometer can only be guaranteed if the generally applicable safety measures and the specific safety instructions in this operating manual are followed during operation.

The smooth functioning and operational safety of the photometer can only be guaranteed under the environmental conditions that are specified in chapter 7 TECHNICAL DATA.

If the photometer was transported from a cold environment to a warm environment, the formation of condensate can lead to the faulty functioning of the meter. In this event, wait until the temperature of the meter reaches room temperature before putting the meter back into operation.

Safe operation

If safe operation is no longer possible, the photometer must be taken out of operation and secured against inadvertent operation.

Safe operation is no longer possible if the photometer:

- has been damaged in transport
- has been stored under adverse conditions for a lengthy period of time
- is visibly damaged
- no longer operates as described in this manual.

If you are in any doubt, contact the supplier of your photometer.

2.4 Handling of hazardous substances

When developing test sets, WTW carefully sees that the tests can be carried out as safely as possible. Some hazards by dangerous substances, however, cannot always be avoided.



Warning

Improper handling of certain reagents can cause damage to your health.

In any case follow the safety labels on the packing and the safety instructions of the package insert. Protective measures specified there have to be followed exactly.

Safety datasheets

The safety datasheets of the chemicals comprise all instructions on safe handling, occurring hazards, preventive actions and actions to take in hazardous situations. Follow these instructions in order to work safely.

3 Commissioning

3.1 Scope of delivery

- Spectrophotometer photoLab® 6600 UV-VIS
- Power pack connection cable
- Buffer batteries 4 x AA alkaline manganese (Mignon)
- Zero cell (16 mm, round)
- Short instructions
- CD-ROM with
 - Detailed operating manual
 - Analysis instructions
 - SpectralTransfer software
 - Software update "Chinese character set" (see section 4.19.3)

Packing

This photometer is sent out in a protective transport packing.



Caution

Keep the original packing including the inner packing to protect the instrument against hard shocks if it has to be transported.

The original packing is also required for the proper return of the instrument if it has to be repaired.

Note that damage caused by improper transport voids all warranty claims.

3.2 Initial commissioning

Perform the following activities:

- Insert the buffer batteries (see section 3.2.1)
- Connect the power supply (see section 3.2.2)
- Switch on the photometer (see section 3.2.3)
- Set the language (see section 3.2.4)
- Set the date and time (see section 3.2.5)
- Carry out a zero adjustment (see section 4.4)



Note

When you set the language, date and time according to the sections and of this operating manual you will quickly become familiar with the simple operation of the photoLab® 6600 UV-VIS. More detailed instructions on operation are given in section 4.2 GENERAL OPERATING PRINCIPLES.

3.2.1 Inserting the buffer batteries

The buffer batteries supply the integrated clock while the photometer is switched off. Four alkaline manganese batteries (type AA or Mignon) separately included in the scope of delivery are used as the buffer batteries.

Insert the batteries as follows:

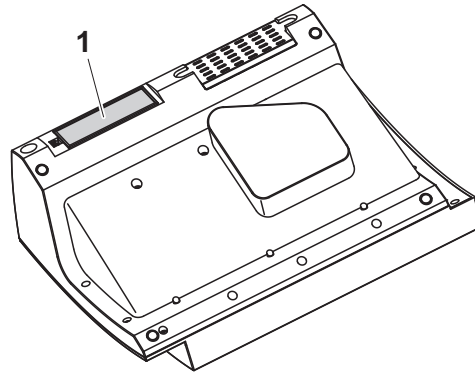

- 1 Turn the photometer upside down and place it on a soft surface.
- 2 Open the lid of the battery compartment (1).
- 3 Insert the four batteries in the battery compartment. Make sure that the poles of the batteries are in the correct position. The \pm signs on the batteries must correspond to the \pm signs in the battery compartment.
- 4 Close the lid of the battery compartment.

Battery service life

The power consumption of the clock is very low. The lifetime of high quality batteries is at least 5 years.

3.2.2 Connecting the power supply

The power is supplied with the aid of the enclosed plug-in power pack. The power pack supplies the photometer with low voltage (12 VDC).



Caution

The line voltage of the usage location must fulfill the specifications stated on the power pack (the specifications are also given in chapter 7 TECHNICAL DATA). Always use the supplied 12 V original power pack only.

Connecting the plug-in power pack

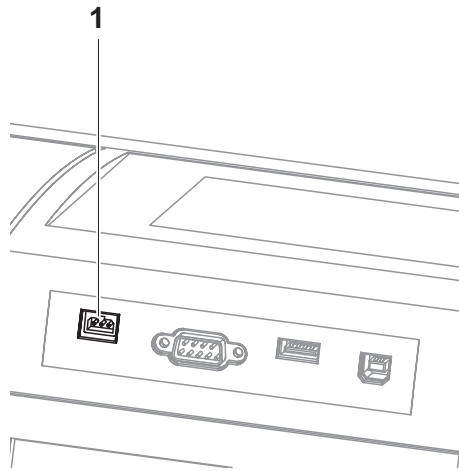

1 Connect the miniplug of the power pack to the socket (1) of the photometer.

2 Connect the power pack to an easily accessible power socket.

The display illumination switches itself on and then off again.

Operation with a mobile 12 V power source

You can also operate the photoLab® 6600 UV-VIS on the move and independent of the local power supply.

To do so, a 12 V power supply such as a commercial 12 V portable power source or a 12 V car battery and the Car Adapter photoLab® 6xxx available as an accessory is required (see section 8.1).

More details on operation are given:

- in section 3.3.6 and
- with the Car Adapter photoLab® 6xxx.

3.2.3 Switching on the photometer for the first time

During the initial commissioning, the photometer automatically guides you through the setting of the meter language, date and time after switching on (see following sections).

Language	16.04.07 9:52
Deutsch ✓	
English	
Français	
Español	
Italiano	
Bulgarian/Български	
Česko	
Chinese/ 中文	
Traditional Chinese/ 繁體中文	
Greek/Ελληνικά	
Indonesian/Indonesia	

1 Press <ON/OFF>.

The photometer is switched on.

The display switches to the setting of the language (see section 3.2.4).

After the setting of the language the photometer carries out the self-test.

When the initial commissioning is completed, the photometer displays the *Home* menu each time after it is switched on and after the self-test (see section 4.1).

3.2.4 Setting the language

During the initial commissioning the photometer automatically guides you to the setting of the meter language after switching on.

Language	16.04.07 9:52
Deutsch ✓	
English	
Français	
Español	
Italiano	
Bulgarian/Български	
Česko	
Chinese/ 中文	
Traditional Chinese/ 繁體中文	
Greek/Ελληνικά	
Indonesian/Indonesia	

1 Select a language with <▲><▼>.

2 Confirm the selected language with <START-ENTER>.

The language has been set.

The currently selected language is marked by a tick.

The display switches to the setting of the *Date* and *Time* (see section 3.2.5).

After the initial commissioning, you can change the language in the *General setup / Language* menu at any time (see section 4.2.4).

3.2.5 Setting the date and time

During the initial commissioning, the instrument automatically guides you to the setting of the time and date after the setting of the language.

Date/Time	16.04.07 9:52
Date	16.04.2007
Time	9:52:09
OK	

The *Date/Time* menu is open.

Using <▲><▼>, select a menu item and confirm or open it with <START·ENTER>.

- 1 Select and confirm *Date*.

The input field for the current date pops up.

Date/Time	16.04.07 9:52
Date	16.04.2007
Time	9:52:09
Date	
23 .10.2006	
OK	

- 2 Enter the current date with <0...9> and confirm.

The input field closes.
The date is accepted.

- 3 Select and confirm *Time*.

The input field for the current time pops up.

Date/Time	16.04.07 9:52
Date	16.04.2007
Time	9:52:09
Time	
10 : 22 : 09	
OK	

- 4 Enter the current time with <0...9> and confirm.

The input field closes.
The time is accepted.

After the initial commissioning, you can change the date and time in the *General setup / Date/Time* menu at any time (see section 4.2.4).

3.3 Connecting optional accessories

3.3.1 Communication interfaces

Connections

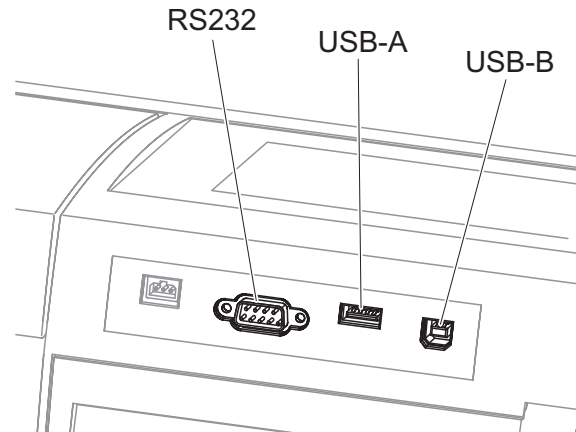

Fig. 3-1 Communication interfaces on the rear panel

You can connect the following accessories to the photometer:

- PC (see section 3.3.2)
- Printer (see section 3.3.2)
- USB storage media (see section 3.3.3)
- USB-PC keyboard (see section 3.3.4)
- Barcode reader (see section 3.3.5)
- Car Adapter photoLab® 6xxx (see section 3.3.6)



Note

If you want to connect several USB devices such as a USB-PC keyboard and a USB memory device to the meter, you can increase the number of USB-A sockets by a commercially available USB-2 hub with separate power supply.

3.3.2 PC/printer

PC and printer can be connected to the photometer as follows:

Interface	PC	Printer	Functions
RS232	✓	✓	<p>The data is sent to the interface with <PRINT>.</p> <ul style="list-style-type: none"> ● If a printer is connected the data is printed out. ● If a PC is connected, the data can be received with a terminal program (see section 4.13).
USB-A		✓	<p>The data is printed out with <PRINT>.</p>
USB-B	✓	-	<p>Enables the direct connection of photometer and PC. With this you can transmit measurement data to the PC (see section 4.12section 4.13) or update the photometer software (see section 4.19.1).</p> <p>The direct connection with the PC is established with the aid of the "SpectralTransfer" program. The program is provided on the supplied CD-ROM.</p> <p>More instructions on how to establish the connection are given in the operating manual of the "SpectralTransfer" program (see CD-ROM).</p>



Note

Suitable are all printers that can interpret the PCL-3 printer control language.

Operation at RS232

Connect the RS232 interface to the devices as follows:

- PC: with a commercially available zero modem cable
- Printer: with a commercially available RS232 printer cable

The cables are available in specialized computer shops.

Set up the following interface data at the PC/printer:

Baud rate	Selectable from 1200, 2400, 4800, 9600, 19200 The baud rate must agree with the baud rate set on the PC/printer.
Flow control ("handshake")	none
Parity	none
Data bits	8
Stop bits	1

3.3.3 USB memory device

Using a USB memory device (such as a USB memory stick), you can

- Update the meter software and method data (section 4.19)
- Transmit data to the USB memory device (section 4.11)

USB memory devices are connected to the USB-A interface.

**Note**

Follow the instructions on the use of USB storage media (see section 4.11.2).

3.3.4 PC keyboard

With the PC keyboard it is possible to enter letters, e.g. to assign names for identification (ID).

In addition, the following keys of the PC keyboard are assigned with the following functions of the photometer:

PC keyboard	Photometer
Enter	<START·ENTER>
Esc	<ESC>
F1 to F4	Function keys <F1> to <F4>

The USB-PC keyboard is connected to the USB-A interface.

3.3.5 Barcode reader

The barcode reader enables the simplified entering of alphanumeric character strings and can be used in all operating situations that require the entry of text or numerals. The barcode reader is connected to the USB-A interface.

3.3.6 Car Adapter photoLab® 6xxx

With the Car Adapter photoLab® 6xxx, you can operate the Pharo 6100 and Pharo 6600 spectrophotometers on the move and independent of the local power supply.

To do so, a 12 V power supply such as a commercial 12 V portable power source or a 12 V car battery is required.

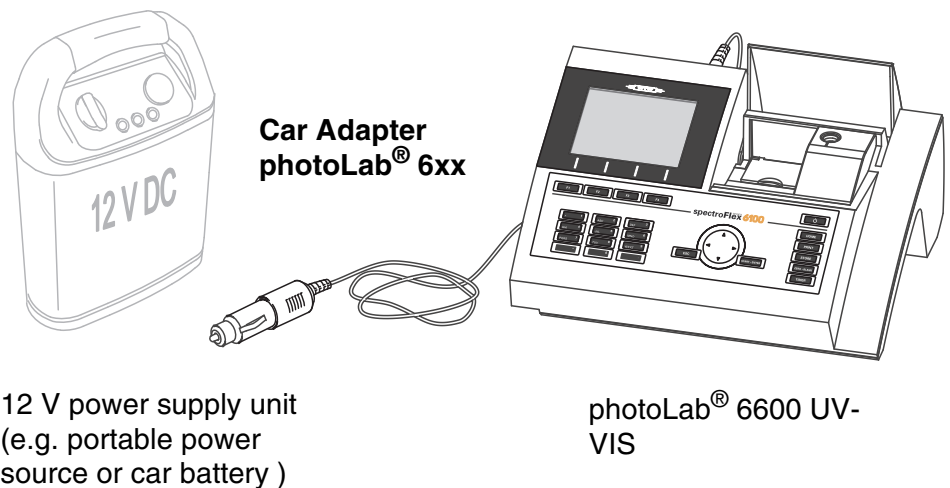

12 V power supply unit
(e.g. portable power
source or car battery)

photoLab® 6600 UV-
VIS

Safety instructions

For operation with an external battery, follow the safety instructions of the battery.

Make sure the power source is suitable for operation of the spectrophotometer (see technical data of the power source and technical data of the spectrophotometer).

Operating time with a battery

The maximum operating time depends on various factors:

- Battery (e.g. nominal capacity, condition, age)
- Operating mode of the photometer (e.g. frequency of measurements)
- Photometer (instrument type)

Example:

Operating time with a 12 V / 19 Ah type battery in optimum condition: approx. 16 h

**Note**

The spectrophotometer consumes electricity even while it is in standby mode.

We recommend to disconnect the photoLab® 6600 UV-VIS if you do not use the spectrophotometer during battery operation.

**Technical data
Car Adapter
photoLab® 6xxx**

Cable length	2 m
Max. voltage	12 V
Max. current	8 A

4 Operation

4.1 Switching on or off the photometer

Switching on

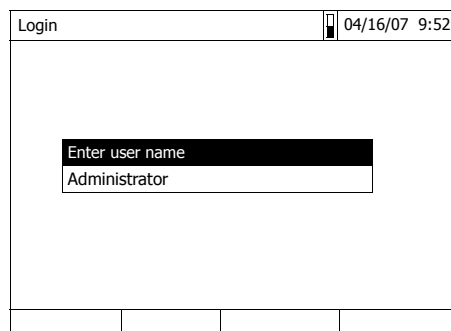
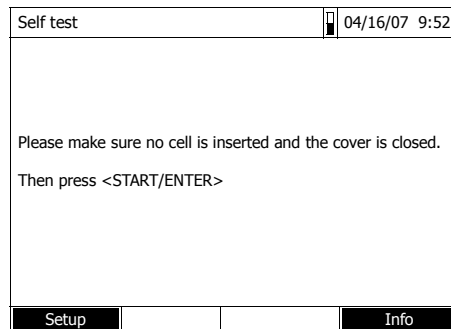

Starting the Self test

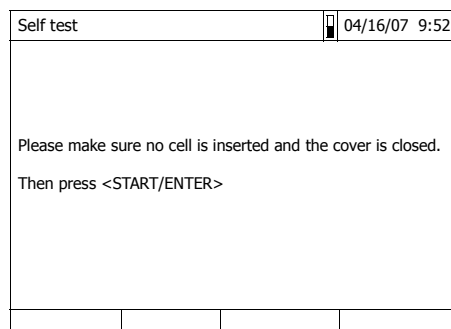

- 1 Switch the photometer on with **<ON/OFF>**.

The display shows

- the *Self test* dialog (if the user management is not active).

or

- the *Login* dialog (if the user management is active).

With activated user management:

- 2 Login
Enter user name and password or register as a guest (see section 4.15.4).
Then the photometer displays the *Self test* dialog.

- 3 Remove all cells and close the cell shaft cover.

- 4 Start the self-test with **<START·ENTER>**.

The photometer carries out the self-test.

Self test During the self-test, all cells must be removed and the cell shaft cover closed.

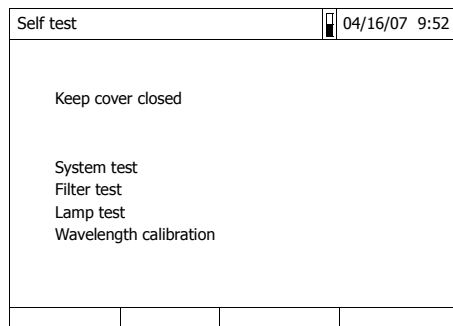

The self-test includes:

- the test of the memory, processor, internal interfaces, filter and lamp
- a calibration for each wavelength

After the self-test is completed, the main menu is displayed.



Note

The result of the self-test can be viewed and printed with the *[Info]* function key (see section 4.17).

Warm-up time

After switching on the photometer requires a warm-up time of 15 minutes. Reproducibility of measurement data is restricted during the warm-up time. Therefore, do not measure during the warm-up time.

During the warm-up time, a progress bar appears on the display next to the date. The progress bar disappears as soon as the warm-up time is over.

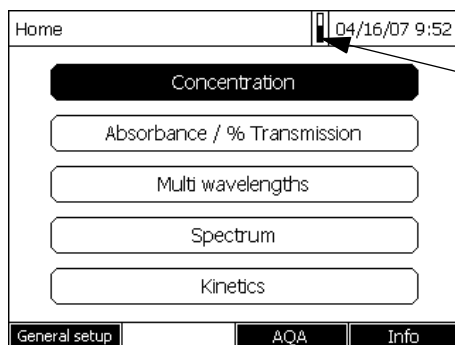

Progress bar during warm-up time

AutoCheck With the AutoCheck function the photometer checks and calibrates the optical measuring unit. The AutoCheck is automatically carried out if measurement settings were changed since the last measurement, e.g.:

- if a different wavelength was selected or
- if a different method was selected.

If necessary, the photometer asks you to remove the cell from the cell shaft.

With unchanged measurement settings, the AutoCheck is carried out in the background at regular intervals of 5 minutes. The AutoCheck can only be carried out in the background if the cell shaft is empty. If a cell is in the cell shaft the AutoCheck is carried out only after the cell was removed.



Note

Remove the cell from the cell shaft after every measurement. Thus the photometer can carry out the regular AutoCheck.

Cells must be completely removed from the cell shaft.

Cells that are removed only half disturb the AutoCheck measurement and, as a consequence, falsify measured values until the next AutoCheck is carried out.

Plastic cells that are not recognized by the automatic cell recognition also disturb the AutoCheck.



Note

During a running kinetic measurement the photometer cannot carry out any AutoCheck. That is why in this case a warm-up time of two hours is required. After this time the signal is stable enough so that the measurement accuracy is secured over a longer period of time.

Display illumination

The photometer automatically switches off the display illumination if no key has been pressed for 5 minutes. The illumination is switched on again with the next keystroke. The function of the key becomes active only with the following keystroke.

Switching off

To switch the photometer off, keep the **<ON/OFF>** key depressed until the photometer is switched off.

4.2 General operating principles

4.2.1 Navigating with function keys and menus



Bild 4-1 Example of navigation with function keys (left) and "classical" menu navigation (right)

Use of the function keys

The function keys F1 to F4 are below the display. Their functions change depending on the operating situation and mode. The current functions are displayed in the function key menu at the bottom edge of the display.

Apart from navigation, the function keys are also used for other operations:

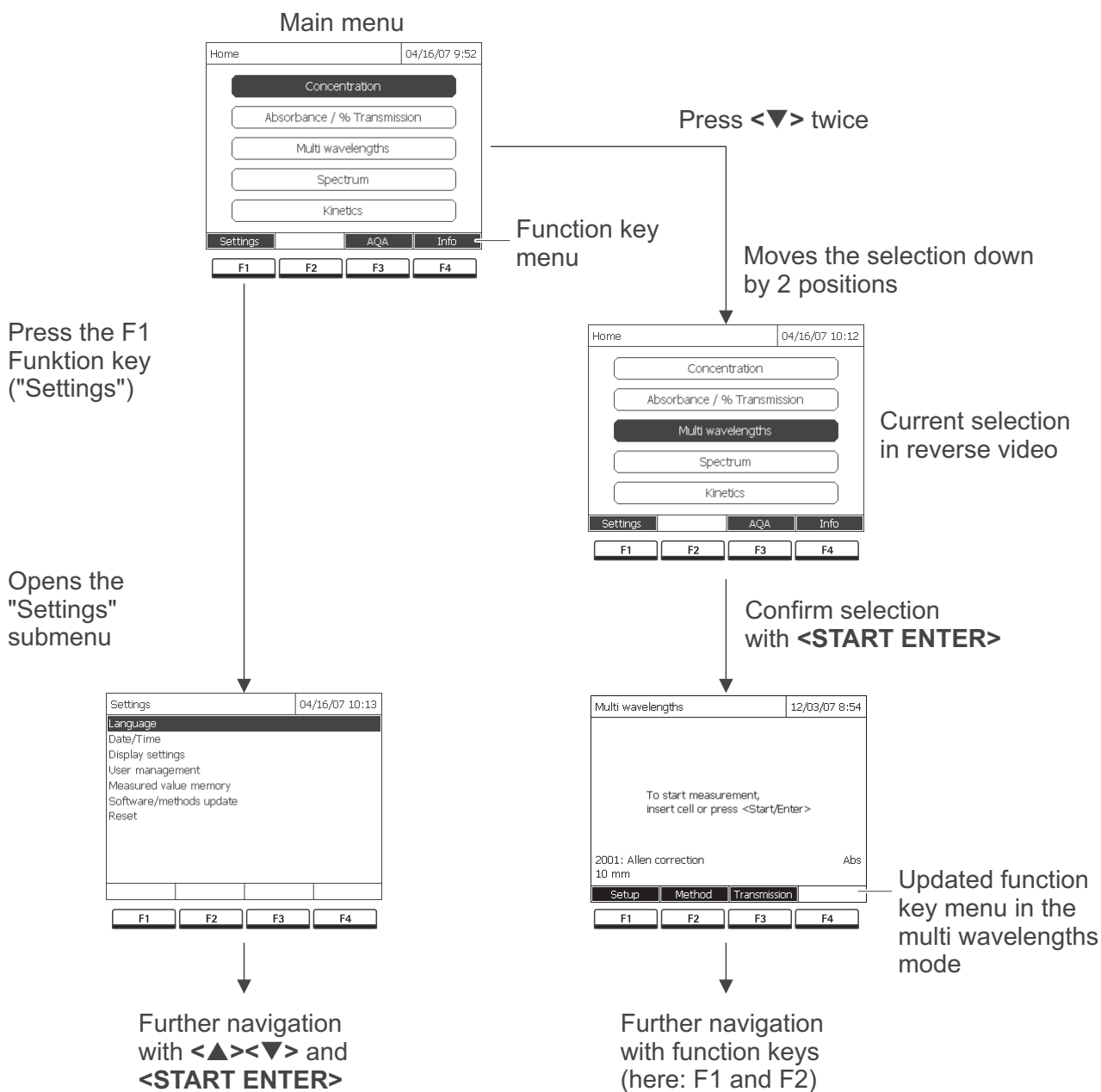
- Opening a selection list or input field
- Executing a command (directly or with intermediate query)
- Switch over between two display options, such as absorbance ↔ transmission

Navigation with arrow keys (<▲><▼>) and <START·ENTER>

These operating elements are used to select an item from a menu or list. The current selection is displayed in reverse video. Pressing of <START·ENTER> confirms the selection.

Apart from navigation, the <START·ENTER> key is also used for other operations:

- Opening a selection list or input field
- Confirming a selection
- Confirming entries of text and numerals
- Executing a command (directly or with intermediate query)
- Activating an item in a selection list (✓ = active)

4.2.2 Display of navigation paths in short form

In this operating manual, the introductory navigation steps leading to individual menus or dialogs are clearly shown in a gray box. The box indicates a section of the menu tree.

Starting point of the description is always the main menu, which can be reached with the **<HOME>** key from any operating situation. From there navigation takes place downward.

Operating example: Navigation to the setting menu for the language

The following example shows the elements of the menu tree with the relevant operating steps:

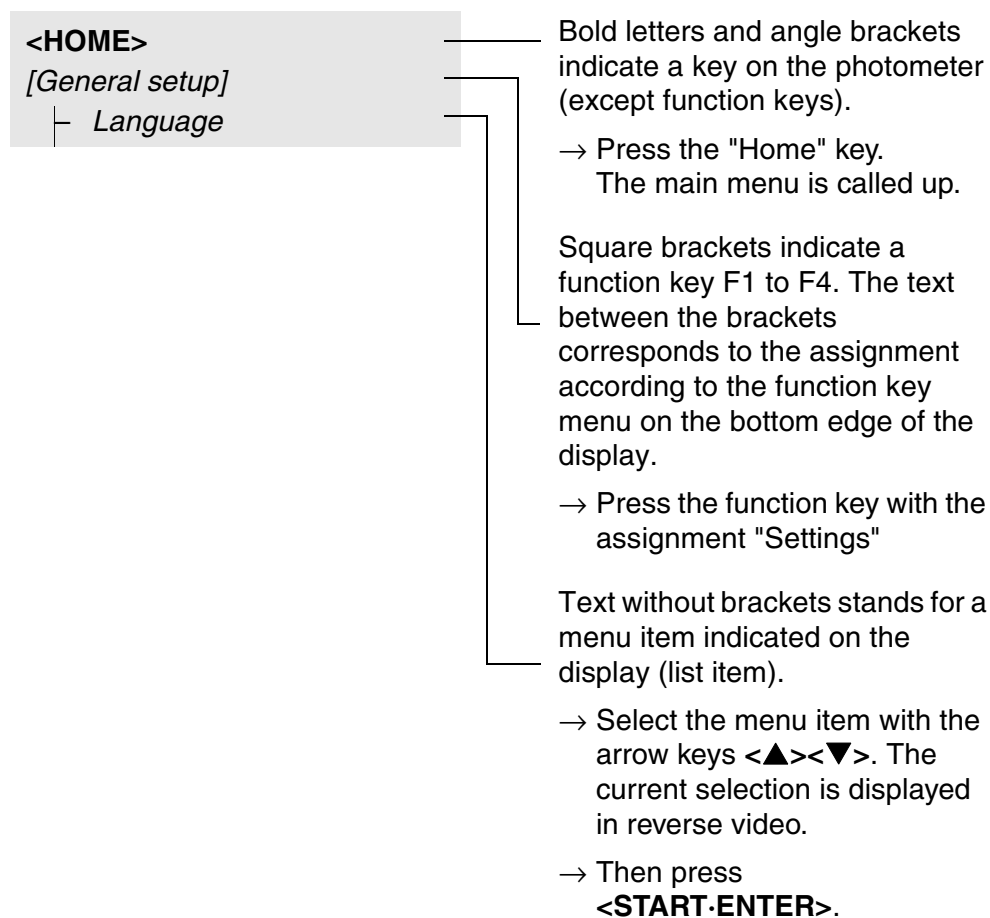

Further navigation options:

- The **<ESC>** key moves you one level up in the menu tree.
- The **<HOME>** key directly calls up the main menu.



Note

If you are "lost" in a menu, press **<HOME>** and restart navigating from the main menu.

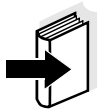
**Note**

The complete menu tree is given in the appendix of this operating manual.

4.2.3 Entry of numerals, letters and characters

Numerals, letters, punctuation marks and special characters are entered with the alphanumeric keypad of the meter or using an external keyboard. Entries are required in operating situations such as the following:

- Entering the date and time
- Entering an ID e.g. when storing measurement data
- Selecting a method with the *[Search]* function
- Programming user-defined methods
- Entering user name and password
- Administrating users

Character set

The following characters are available:

- Numerals 0 ... 9
- Letters A ... Z and a ... z
- Punctuation marks. -
- Special characters ° / + ² ³ # %

Operating principle

Entering characters is always possible if there is an input field on the display.



The numerals and characters (except for the small letters) assigned to the keys of the alphanumeric keypad are printed on the keys. Example: With the **<7/PQRS>** key you can enter the following characters: 7, P, Q, R, S, p, q, r, s.

Select the required character by pressing the key several times (similar to a mobile phone). When pressing a key that is assigned to several characters once, the respective numeral appears first. To enter a numeral, one keypressing is always sufficient.

When pressing the key for the first time a line pops up that displays all characters possible with this key. The currently selected character is highlighted.

A character is taken over in the input field if

- the character is highlighted for more than one second,
- the character is confirmed with **<START·ENTER>**,
- another alphanumeric key is pressed.



Note

During mere number entries (such as entering a wavelength), the keys of the alphanumeric keypad are assigned to the respective numeral only. Each keypressing directly enters the numeral (like a pocket calculator).

Special characters

Special characters are entered with the <1/*> key.

**Operating example:
Entering the ID**

The *Enter ID* input field appears if you press the <STORE> key while the storing symbol is visible. In the following example a measurement dataset with the ID "Test" is stored.

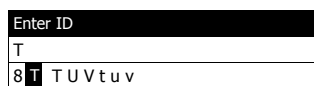
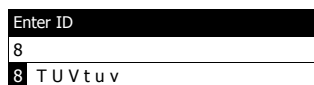

- 1 Press <8/TUV> several times until "T" appears in the input line.

Below the input field, a selection line pops up with all characters that are available for this key, e.g. *8 T U V t u v*.

The currently selected character is highlighted.

After approx. one second the character is taken over and the selection line closed.

- 2 Complete the ID with <A...9> and confirm.

Correcting incorrect entries

Using <◀>, erase all characters until you have reached the incorrect digit and repeat the entry from there.

4.2.4 Detailed operating example: Changing the language

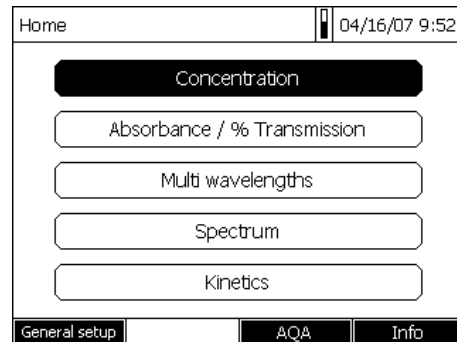

- 1 Call up the main menu with the **<HOME>** key.
- 2 Open the *General setup* menu with the F1 function key [*Setup*].

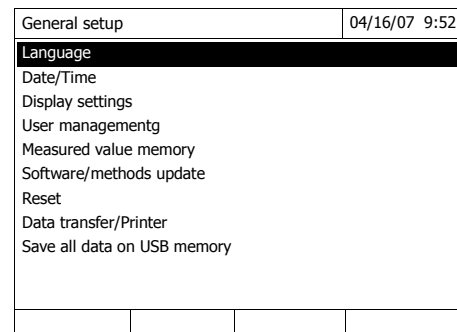

- 3 Using **<▲><▼>**, select the *Language* menu item and open with **<START-ENTER>**.

The *Language* menu shows a list with the available languages. The currently active language is marked by a tick.



- 4 Select the required language from the list with **<▲><▼>** and confirm with **<START-ENTER>**.

The selected language is taken over immediately. The photometer moves up one menu level.

4.3 Photometer settings and system administration

The general photometer settings are done in the <HOME> -> *General setup* menu. The general photometer settings comprise:

- Language (see section 4.3.2)
- Date/time (see section 4.3.2 and section 4.2.4)
- Display characteristics (see section 4.3.3)
- User management (see section 4.15)
- Administration of the measurement data memory (see section 4.11)
- Software and method update (see section 4.19)
- Reset of the settings to default values (see section 4.16)
- Settings for data transmission (see section 4.13.2)

4.3.1 Language

The complete list of the available instrument languages is given in the *Sprache/LanguageLanguage* menu of the photometer and in chapter 7 TECHNICAL DATA.



Note

You can select the "Simplified Chinese/ 中文 " or "Traditional Chinese/ 繁體中文 " language only if the Chinese character set has been previously installed (see section 4.19.3).



Note

How to set the language is described in detail in the operating example in section 4.2.4.

4.3.2 Date/Time

The date format is set automatically with the language setting. According to the locally usual version, the date format is displayed in the order, Day.Month.Year (*DD.MM.YY*) or Month/Day/Year (*MM/DD/YY* or *MM.DD.YY*).

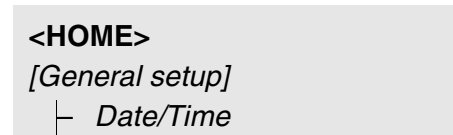

The *Date/Time* menu is open.

1 Select and confirm *Date*.

The input field for the current date pops up.

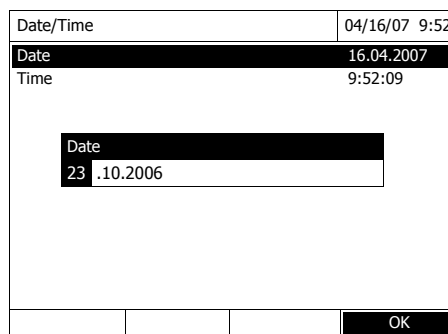

2 Enter the current date with <0...9> and confirm.

The input field closes.
The date is accepted.

3 Select and confirm *Time*.

The input field for the current time pops up.

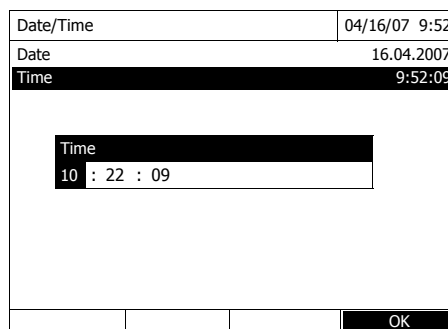

4 Enter the current time with <0...9> and confirm.

The input field closes.
The time is accepted.

4.3.3 Display settings

Here you can adjust the display contrast to the lighting conditions.

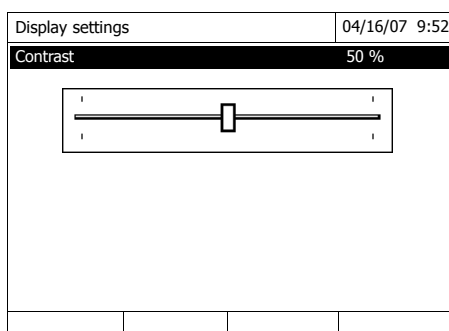
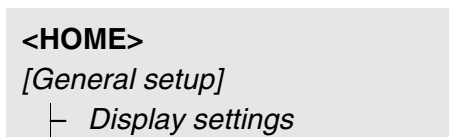

- 1 Select and confirm *Contrast*.
A slide control for the display contrast appears.
- 2 Using <<>><>, set the display contrast and confirm.

4.4 Zero adjustment

A valid zero adjustment is required for the calculation of measured values in the modes, *Concentration*, *Absorbance / % Transmission*, *Multi wavelengths* and *Kinetics*. With a zero adjustment, the absorbance of a cell filled with distilled water ("zero cell") is measured and stored.

Zero adjustment for absorbance measurements

The zero adjustment has to be carried out separately for each cell type and each used wavelength. If necessary, the photometer reminds you that a zero adjustment is due.

Factory zero adjustment for concentration measurements

For all measurements with WTW test sets (*Concentration* mode), a factory zero adjustment is available in the delivery condition. We recommend replacing it with a zero adjustment of your own.



Note

The cells must be absolutely clean and free of scratches.

Always use a cell of the same type for zero adjustment and measurement of the sample.

Notes on zero adjustment

Zero adjustment with round cells:

- Only use clean, scratch-free round cells with distilled water. The minimum filling level is 20 mm. A ready zero cell is included in the scope of delivery of the photometer and PhotoCheck (see chapter 8 ACCESSORIES AND OPTIONS).
- A ready zero cell can, in principle, be used any number of times. We recommend, however, to regularly check the zero cell for visible contamination and scratches and refill or exchange it if necessary (at least every 24 months).

Zero adjustment with rectangular cells:

- For rectangular cells, the zero adjustment must be carried out with the same cell type (manufacturer and glass type [e.g. optical glass, quartz glass]) that is used for measurement. This is important because cells of different manufacturers have different absorption behavior. When changing the cell type repeat the zero adjustment with the new type.
- Prior to zero adjustment, clean the rectangular cell and fill it with distilled water. The minimum filling level is 20 mm.
- Rectangular cells always have to be inserted in the cell shaft with the same orientation for measurement and zero adjustment (e.g. cell printing on the left side).



Note

Ordering information is given in chapter 8 ACCESSORIES AND OPTIONS. The cells listed in the chapter 8 ACCESSORIES AND OPTIONS are especially adapted to the WTW test set program. General requirements of the cells are given in chapter 7 TECHNICAL DATA. Note that the spectral transparency of the cell must be suitable for the intended application (example, quartz cell for UV range).

Carrying out a zero adjustment

The zero adjustment takes place similarly in the *Concentration*, *Absorbance / % Transmission*, *Multi wavelengths* and *Kinetics* modes.

- 1 In the respective mode, press the **<ZERO·BLANK>** key.
- 2 In *Concentration* mode only:
Select and confirm *Zero adjustment*.

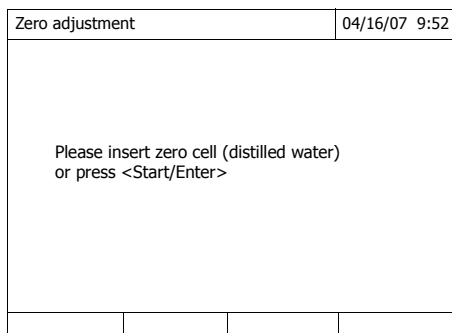
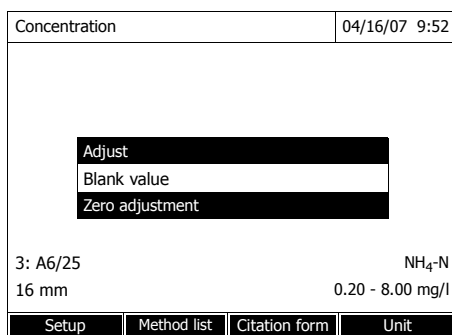

The zero adjustment window pops up.

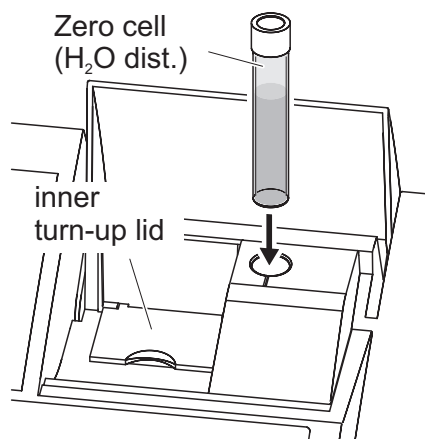

- 3 Close the inner turn-up lid.
- 4 Depending on the cell type, insert the zero cell as follows:
Round cell:
Insert the round cell in the round cell shaft so it touches the bottom.
If the inner turn-up lid is opened too wide, a message prompts you to close the inner turn-up lid.

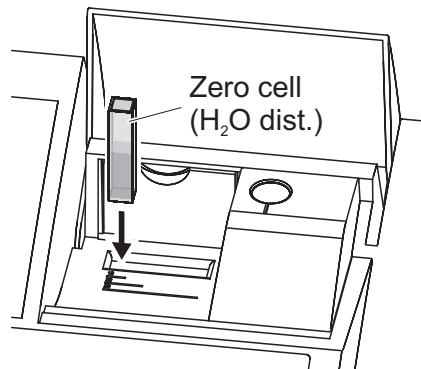

Rectangular cell:

Open the inner turn-up lid.

Insert the rectangular cell vertically so it touches the bottom and left edge of the cell shaft. The opaque sides of the rectangular cell must point to the front and back.

The photometer has an external light recognition. If there is too much external light, a message prompts you to close the cell shaft cover.

The photometer automatically starts the zero adjustment and subsequently stores the value.

- 5 After a successful zero adjustment switch to measurement with [OK].

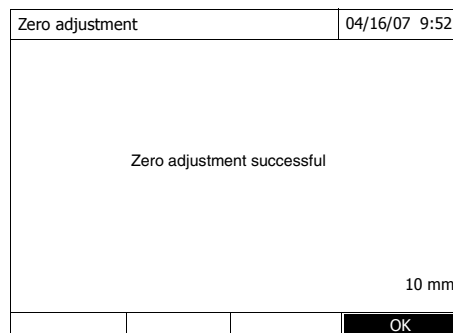

Validity of the zero adjustment

The data of the zero adjustment is stored in the photometer separately for each cell type. As long as the data is valid, it is automatically used again after a temporary change to a different cell type. The validity depends on the respective mode:

Mode	Validity of the zero adjustment
<i>Concentration</i> (permanently programmed methods)	● Till the next zero adjustment
<i>Absorbance / % Transmission</i>	● Till the next zero adjustment with the same wavelength *
<i>Concentration</i> (user-defined methods) and <i>Multi wavelengths</i>	● Till the next zero adjustment for the same method *
<i>Kinetics</i>	● Till another kinetic profile is loaded ● Till the <i>Kinetics</i> mode is exited or the photometer is switched off

* After the wavelength or method respectively was temporarily exited the photometer displays that a zero adjustment is available and the time it was carried out. You can then decide whether to use this zero adjustment or carry out a new zero adjustment.

When to repeat the zero adjustment?

We recommend to repeat the zero adjustment in the following cases:

- If the photometer was subject to mechanical stress such as strong shock or transport
- If the ambient temperature changed by more than 5 °C since the last zero adjustment
- At least once per week
- If a new cell type (different manufacturer, different glass type is used)
- Basically each time you want to measure with the highest possible accuracy.

4.5 Measuring in *Concentration* mode

4.5.1 Measuring cell tests with barcode

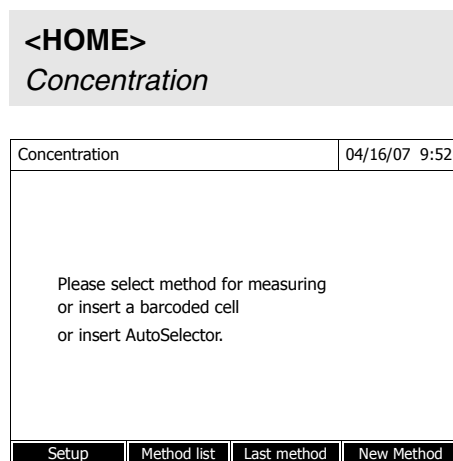

Inserting a cell with barcode starts a measurement.

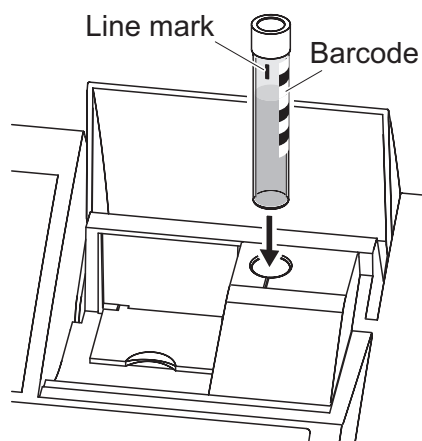

- 1 Open the cell shaft cover.
- 2 Close the inner turn-up lid.
If the inner turn-up lid is opened too wide, a message prompts you to close the inner turn-up lid.
- 3 Insert the barcoded round cell in the round cell shaft so it touches the bottom. When doing so, align the line mark with the notch at the front of the round cell shaft.

The photometer selects the method based on the bar code and automatically starts measurement.

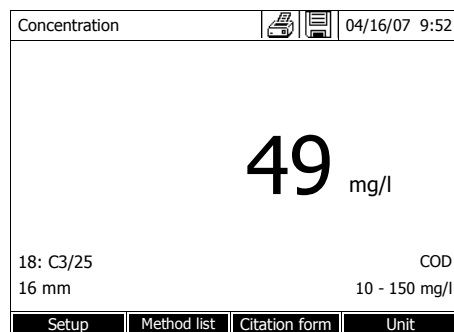

- 4 Further options:
 - Select a different citation form with *[Citation form]*, (e.g. $\text{NH}_4 \leftrightarrow \text{NH}_4\text{-N}$).
 - Select a different measuring unit with *[Unit]*, (e.g. $\text{mg/l} \leftrightarrow \text{mmol/l}$).
 - Make further settings such as dilution or blank value measurements with *[Setup]* (see section 4.5.6).

Display if the value is not within the measuring range (see section 4.5.4).

4.5.2 Measuring reagent tests with AutoSelector

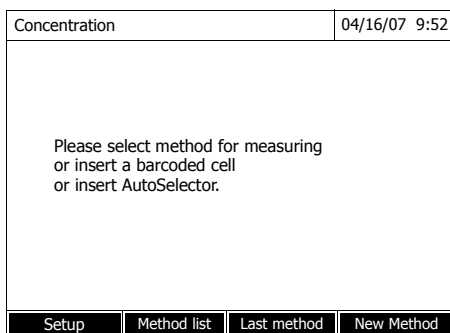
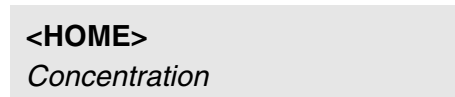

The method is selected by inserting the AutoSelector.

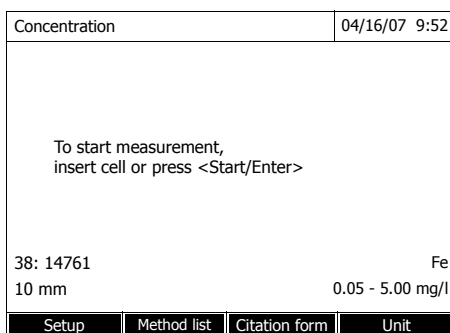

The photometer is ready to measure.

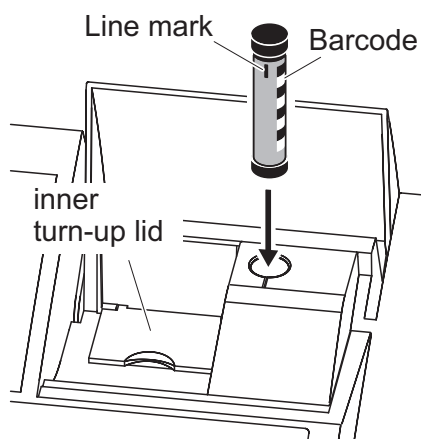

- 1 Open the cell shaft cover.
- 2 Insert the AutoSelector in the round cell shaft so it touches the bottom. When doing so, align the line mark with the notch at the front of the round cell shaft.
 - The photometer selects the correct method with the aid of the barcode.

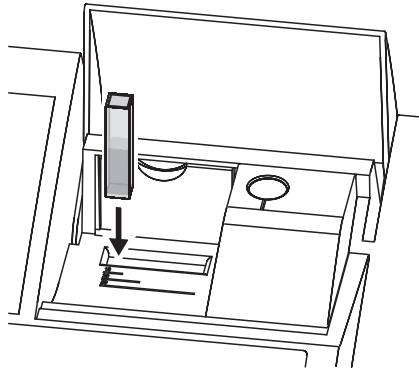

- 3 Open the inner turn-up lid.
- 4 Insert the rectangular cell vertically so it touches the bottom and left edge of the cell shaft. The opaque sides of the rectangular cell must point to the front and back.

The correct measuring range is automatically selected when the rectangular cell (1, 2, 5 cm) is inserted.

The photometer has an external light recognition. If there is too much external light, a message prompts you to close the cell shaft cover.

The photometer starts measuring automatically.

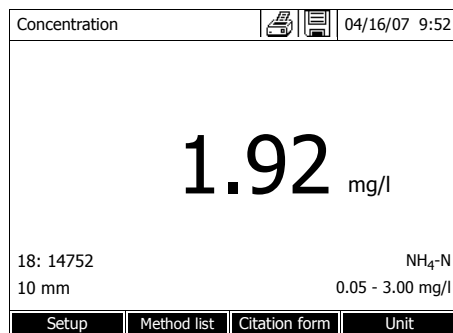

- 5 Further options:
 - Select a different citation form with *[Citation form]*, (e.g. NH₄ <-> NH₄-N).
 - Select a different measuring unit with *[Unit]*, (e.g. mg/l <-> mmol/l).
 - Make further settings such as dilution or blank value measurements with *[Setup]* (see section 4.5.6).

Display if the measured value is not within the measuring range (see section 4.5.4).

4.5.3 Measuring reagent-free tests and user-defined methods

User-defined methods and reagent-free methods normally do not have a barcode and therefore, no automatic method recognition. In such a case, select the method manually:

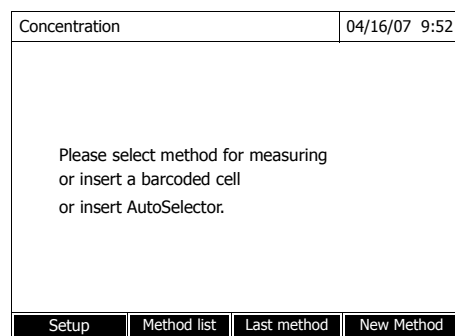
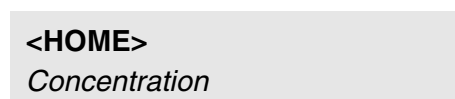

- 1 Select the method manually (see section 4.5.5).

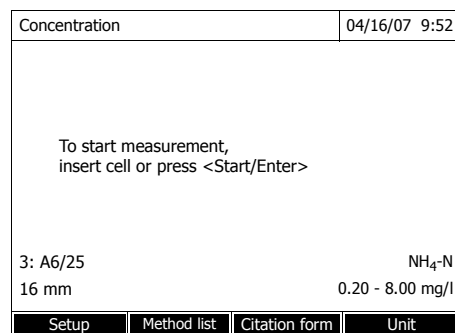

The photometer is ready to measure.

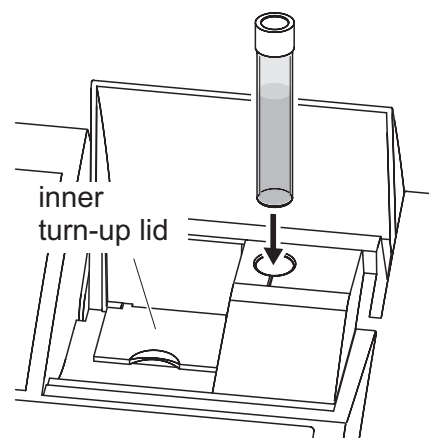

- 2 Depending on the type, insert the cell as follows:

Round cell:

Close the inner turn-up lid.

Insert the round cell in the round cell shaft so it touches the bottom.

If the turn-up lid is opened too wide, a message prompts you to close the inner turn-up lid.

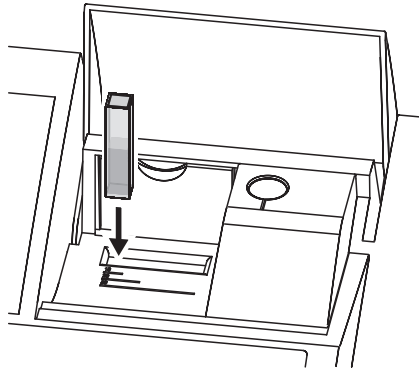

Rectangular cell:

Open the inner turn-up lid.

Insert the rectangular cell vertically so it touches the bottom and left edge of the cell shaft. The opaque sides of the rectangular cell must point to the front and back.

The photometer has an external light recognition. If there is too much external light, a message prompts you to close the cell shaft cover.

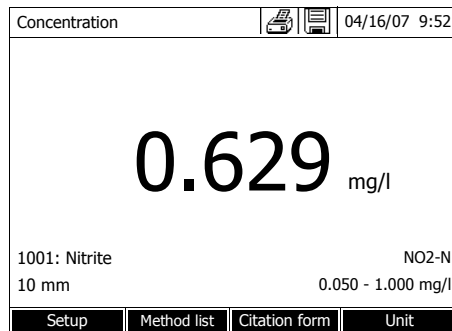

3 Further options:

- Select a different citation form with *[Citation form]*, (e.g. $\text{NH}_4 \leftrightarrow \text{NH}_4\text{-N}$).
- Select a different measuring unit with *[Unit]*, (e.g. $\text{mg/l} \leftrightarrow \text{mmol/l}$).
- Make further settings such as dilution or blank value measurements with *[Setup]* (see section 4.5.6).

Display if the measured value is not within the measuring range (see section 4.5.4).

4.5.4 Exceeding the upper or lower limits of the measuring range

Measured value display if the measured value is outside the measuring range:

Range	Display	Example: MR: 10 - 150 mg/l
	LL < MV < UL	Measured value 128 mg/l
1	UL < MV < UL + 10%	Upper limit of measuring range exceeded by up to 10% and measured value > 150 157 mg/l
	LL - 50% < MV < UL	Lower limit of measuring range undercut by up to 50% and measured value < 10 7 mg/l
2	MV > UL + 10%	Upper limit of measuring range exceeded by more than 10% > 150 mg/l
	MV < LL - 50%	Lower limit of measuring range undercut by more than 50% < 10
3	Invalid measured value e.g. MV < 0	Lines - - - - mg/l

MR = Measuring range

UL = Upper limit value of the measuring range

LL = Lower limit value of the measuring range

MV = Measured value

4.5.5 Selecting a method manually

Selecting the method last used

```
<HOME>
Concentration
└─ [Last method]
```

The method last used is immediately selected.

Selecting a method from the Method list

```
<HOME>
Concentration
└─ [Method list]
```

Select method (all)		04/16/07 9:52	
Search: <input type="text"/>			
1	C3/25	COD	10 - 150 mg/l
2	C4/25	COD	25 - 1500 mg/l
3	A6/25	NH ₄ -N	0.20 - 8.00 mg/l
4	N2/25	NO ₃ -N	0.5 - 25.0 mg/l
5	N5/25	NO ₂ -N	0.010 - 0.700 mg/l
6	P6/25	PO ₄ -P	0.05 - 5.00 mg/l
7	P7/25	PO ₄ -P	0.5 - 25.0 mg/l
160	09717	Pb	0.10 - 5.00 mg/l
67	14834	Cd	0.025 - 1.000 mg/l
39	14552	Cr	0.05 - 2.00 mg/l
Last used			

The list of methods is displayed. The methods are ordered according to the method number. The arrows ▼ or ▲ on the right edge indicate that the list comprises more methods further up or down.

The method last selected is highlighted.

Select the method:

- 1 Select the required method with <▲><▼>. The active selection is displayed in reverse video.
- 2 Accept the selection with <START·ENTER>.

Narrowing down the method list

You can narrow down the method list and thus make the search easier:

- Using [Last used], you can restrict the method list to the ten methods last used.
- With the search function you can search certain character strings in the list. The search takes place as a full-text search of the entire list contents. Thus you can search for a method number or certain citation form.

Search function

Select method (last used)	04/16/07 9:52		
CO_			
14	14540	COD	10 - 150 mg/l
23	14541	COD	25 - 1500 mg/l
All methods			

Search for a character string:

Enter the character string to be searched for in the search window with **<A...9>**.

The list appearing below shows all hits containing the character string. The hit list is updated with each character that is entered.



Note

Note the case sensitivity when searching. It is not required or possible to enter inferior characters. When searching for chemical formulas, inferior characters are treated as normal characters. Example: The search for "NH4" shows all hits that contain "NH4" as well as "NH₄".

4.5.6 Settings for Concentration mode

Prior to measuring, check the settings for the selected method.

```

<HOME>
Concentration
Select a method
└─ [Setup]
    
```

Concentration	04/16/07 9:52		
Dilution ✓			
Sample blank value			
User-defined blank value			
Turbidity correction			
Display absorbance ✓			
AQA			
Edit method			
New method			
Measurement data memory			

The menu shows an overview of all settings.

Active settings are marked by a tick.

Overview of the settings

Menu item	Explanation
<i>Dilution</i>	<p>Here you can set the dilution prior to measuring if you want to use a diluted sample.</p> <p>In the measured value display, the dilution is indicated in the form [1 + x] (parts sample + parts distilled water).</p> <p>For more detailed information on dilution, see section 4.5.7.</p>
<i>Sample blank value</i>	<p>Here you can measure while taking a sample blank value into account.</p> <p>In the measured value display, measurements with sample blank value are marked by [SB] (Sample blank).</p> <p>For more detailed information on sample blank value, see section 4.5.8.</p>
<i>User-defined blank value</i>	<p>If available, a user-defined reagent blank value is used.</p> <p>In the measured value display, measurements with a user-defined reagent blank value are marked by [BV/Lot number].</p> <p>For more detailed information on reagent blank value, see section 4.5.9.</p>
<i>Turbidity correction</i>	<p>Activates/deactivates the automatic turbidity correction.</p> <p>In the measured value display, measurements with automatic turbidity correction are marked by [TURB].</p> <p>For more detailed information on the automatic turbidity correction, see section 4.5.10.</p>
<i>Display absorbance</i>	<p>Activates/deactivates the display of the absorbance value in addition to the main measured value.</p>
<i>AQA</i>	<p>Here you can view and change the AQA settings without discarding the current measurement.</p>
<i>Edit method</i>	<p>Here you can edit user-defined methods.</p>
<i>New method</i>	<p>Here you can create user-defined methods.</p>
<i>Measurement data memory</i>	<p>Here you can view the measurement data memory.</p>

4.5.7 Measuring diluted samples

If the concentration of a sample exceeds the measuring range of a method, you can specifically dilute the sample so that the concentration of the diluted sample is in the measuring range of the method. Thus a valid measurement is possible.

After entering the factor for the dilution the meter converts the concentration to that of the undiluted sample.



Note

Optimum measurement results are achieved if the concentration of the diluted sample is in the middle of the measuring range of the method after diluting.

Setting the dilution

<HOME>
Concentration

Concentration	04/16/07 9:52
Please select method for measuring or insert a barcoded cell or insert AutoSelector.	
Setup	Method list
Last method	New Method

Inserting a cell with barcode starts a measurement.

If a cell without barcode is used:
 Select the method manually
 (see section 4.5.5).

Concentration	04/16/07 9:52
To start measurement, insert cell or press <Start/Enter>	
3: A6/25	NH ₄ -N
16 mm	0.20 - 8.00 mg/l
Setup	Method list
Citation form	Unit

The photometer is ready to measure.

Concentration	04/16/07 9:52
Sample + distilled water	
1 + _	
3: A6/25 16 mm	NH ₄ -N 0.20 - 8.00 mg/l
Setup	Method list
Citation form	Unit

- 1 Open the setting menu with *[Setup]*.
- 2 Select and confirm *Dilution*. The input field for the dilution pops up.
- 3 Enter and confirm the dilution (<0...9>).
The entered dilution is taken into account with the next measurement.

The entered value for the dilution factor is valid for the selected method only. The dilution factor is erased if

- the photometer is switched off
- a different method is selected
- the factor 0 is entered in the *Dilution* menu.

If a dilution factor is active, it is indicated on the display during measurement in the form [1 + x].

4.5.8 Sample blank value

By measuring and using a sample blank value, measurement errors due to coloring and turbidity of the sample matrix can be eliminated to a large extent.

The sample blank value is a characteristic of the sample (coloration) to be currently determined. It is determined by measuring the blank sample.

The blank sample is prepared from the sample by adding reagents to it and is especially adapted to measurement with the test to be measured. No chromophoric reagents, however, are added for the preparation of the blank sample.



Note

Due to the addition of reagents the sample is diluted. This can also change the pH value of the sample. For this reason the blank sample also has to be diluted and the pH value adjusted accordingly.

Validity

The sample blank value applies to the next measurement only.

Single and multiple determination

The sample blank value can be determined by single or multiple determination. With multiple determination, the sample blank value is calculated as the median from the individual measured values.

Measuring the sample blank value

<HOME>
Concentration

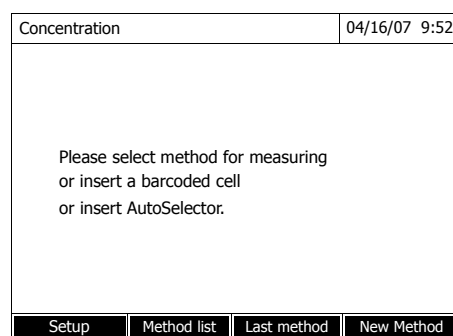

Inserting a cell with barcode starts a measurement.

If a cell without barcode is used: Select the method manually (see section 4.5.5).

Concentration	04/16/07 9:52
To start measurement, insert cell or press <Start/Enter>	
3: A6/25 16 mm	NH ₄ -N 0.20 - 8.00 mg/l
Setup	Method list
Citation form	Unit

The photometer is ready to measure.

- 1 Open the setting menu with *[Setup]*.
- 2 Select and confirm *Sample blank value*.

Sample blank value	04/16/07 9:52
To start measurement, insert cell or press <Start/Enter>	
3: A6/25 16 mm	NH ₄ -N 0.20 - 8.00 mg/l

- 3 Insert the cell with a suitable blank sample.

The first single measurement for the sample blank value takes place.

The following data is displayed as the result:

- The measured absorbance from the (last) single measurement.
- The median from all single measurements carried out up to now.

Sample blank value	04/16/07 9:52
Last measured absorbance 0.115 Median 0.115 (1 Measurement(s))	
3: A6/25 16 mm	NH ₄ -N 0.20 - 8.00 mg/l
Next meas.	Discard
	Apply

- 4 If necessary, carry out further single measurements for the formation of the median with *[Next meas.]* or discard the last single measurement with *[Discard]*.

- 5 To accept the median value, press *[Apply]*.

Concentration	04/16/07 9:52
[SB]	
To start measurement, insert cell or press <Start/Enter>	
3: A6/25 16 mm	NH ₄ -N 0.20 - 8.00 mg/l
Setup	Method list
Citation form	Unit

The photometer is ready to measure.

The use of the sample blank value is indicated by [SB] in the top right corner of the display.

4.5.9 Reagent blank value

The evaluation of the photometric measurement always refers to the comparison value of a test sample without the substance to be determined (reagent blank value). Thus the influence of the basic absorbance of the reagents on photometric measurement is compensated for.

In practice, the reagent blank value is measured with the same amount of deionized water instead of sample.

Factory and user-defined reagent blank values

With photometric concentration determination, the reagent blank value is a constant. The method data for all measurements with WTW test sets (*Concentration* mode) include an exactly determined reagent blank value. This value is overwritten if you measure the reagent blank value yourself (setting, *User-defined blank value*, see section 4.5.6).



Note

You can increase accuracy if you determine the reagent blank value with a test of a new lot and use the reagent blank value for all further measurements with this lot. This is especially recommended for measurements in the vicinity of the lower limit of the measuring range. To be able to attribute the reagent blank value in the measured value documentation later, you can enter the lot number of the reagent package (*Lot number*) during the blank value determination.

Validity

The factory blank values always remain stored in the meter and can be activated at any time. The reagent blank values you measured yourself also remain stored in the meter until they are overwritten by a new blank value measurement.

Single and multiple determination

The reagent blank value can be determined with single or multiple determination. With multiple determination, the reagent blank value is calculated as the median from the individual measured values.

User-defined methods

For user-defined methods, you can activate the reagent blank value function as follows only:

Entry type	Function type	Reagent blank value possible?
Entry of a function (with and without entering the ordinate intercept)	Linear	Yes
	Nonlinear	No
Entry of value pairs or measurement and storage of standard solutions (with entering or measuring and storing E0)	Linear	Yes
	Parabola (second-order function)	Yes
	Polygon line	No
Entry of value pairs or measurement and storage of standard solutions (without entering or measuring and storing E0)	Linear	Yes
	Parabola (second-order function)	No
	Polygon line	
	Polygon line through zero	

**Note**

If no value for E0 is stored during the entry of value pairs or the measurement and storing of standard solutions for a nonlinear function (parabola or polygon line), the message, *No blank value correction is intended for this method.* appears when the *User-defined blank value* function is activated. The blank value (E0) can be entered later by editing the method.

Measuring the reagent blank value

<HOME>
Concentration

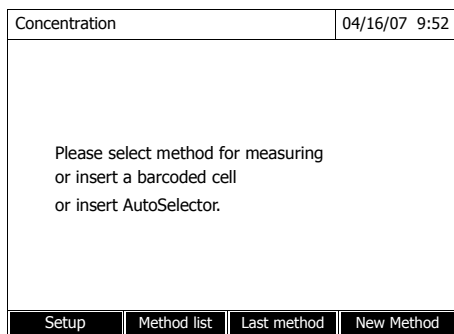

Inserting a cell with barcode starts a measurement.

If a cell without barcode is used:
Select the method manually
(see section 4.5.5).

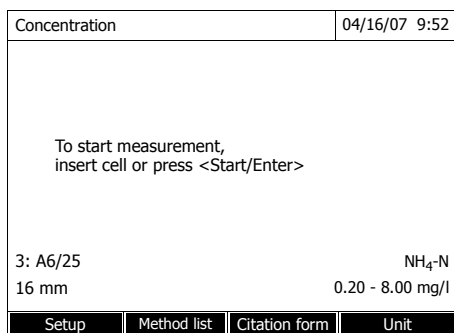

The photometer is ready to measure.

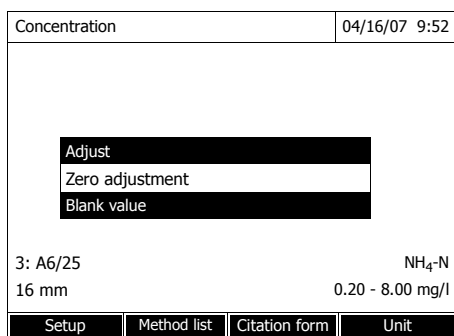

- 1 Using **<ZERO-BLANK>**, open the *Adjust* selection list.
- 2 Select and confirm *Blank value*.

The window for the measurement of the reagent blank value pops up.
The data of the last measurement appears in the measured value display.

Blank value	04/16/07 9:52
To start measurement, insert cell or press <Start/Enter>	
3: A6/25 16 mm	NH ₄ -N 0.20 - 8.00 mg/l

3 Insert the cell with the blank sample.

The first single measurement for the reagent blank value takes place.

The following data is displayed as the result:

- The measured absorbance from the (last) single measurement.
- The median from all single measurements carried out up to now.

Blank value	04/16/07 9:52
Last measured absorbance 0.600 Median 0.600 (1 Measurement(s))	
3: A6/25 16 mm	NH ₄ -N 0.20 - 8.00 mg/l
Next meas.	Discard
Apply	

4 If necessary, carry out further single measurements for the formation of the median with *[Next meas.]* or discard the last single measurement with *[Discard]*.

5 To accept the median value, press *[Apply]*.

The *Lot number* entry field pops up.

6 Enter and confirm the *Lot number* (<**A...9**>). The blank value measurement is completed.

The photometer is ready to measure.

The use of the reagent blank value is indicated by [BV/Lot number] in the top right corner of the display.

Blank value	04/16/07 9:52
[BV/Lot number]	
To start measurement, insert cell or press <Start/Enter>	
3: A6/25 16 mm	NH ₄ -N 0.20 - 8.00 mg/l
Setup	Method list
Citation form	Unit

4.5.10 Automatic Turbidity correction

The *Turbidity correction* function activates the automatic recognition and compensation of the light absorption caused by turbid substances.

After activating the function remains permanently switched on. Measured values that were measured with *Turbidity correction* are labeled with [TURB] (turbidity correction) on the display and in the documentation (printout and memory).

The *Turbidity correction* function is not active in the delivery condition.



Note

The setting for automatic turbidity correction is used with all methods where the automatic turbidity correction makes sense. The photometer automatically decides whether or not to use the function.

Switching on the turbidity correction

The automatic turbidity correction is activated and deactivated in the setting menu of the concentration measurement (see section 4.5.6 SETTINGS FOR CONCENTRATION MODE).

4.5.11 Programming / modifying user-defined methods

Overview

For *Concentration* mode, you can develop and store yourself user-defined methods under the method numbers 1001 to 1100. The photometer software supports you when creating the methods.

Calibration data and calibration function

In photometry, the calibration function describes the dependency between the measured parameter (e.g. concentration) and the photometric measurement result (e.g. absorbance) of a sample. The knowledge of this dependency is a prerequisite for the development of a photometric method. The calibration function is usually determined by means of a series of measurements with standard solutions of known concentrations (nominal value), e.g. a 10-point calibration.



Note

In measuring operation, the reverse calibration function is used to output the measured absorbance as a concentration value.

Line types

The dependency between the nominal value and absorbance is often linear in a wide range as shown in the following example:



Bild 4-2 Example of a linear calibration function after a 10-point calibration

In the case of a linear dependency, the calibration function is determined by means of linear regression. The slope and axis intercept (E_0) are the characteristics of the calibration line.

In the case of a nonlinear dependency, the points of the measuring ranges can be connected to each other as a polygon line or approximated as a parabola:

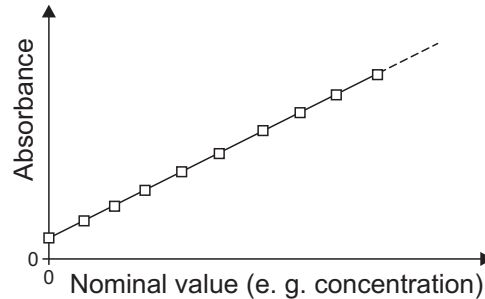

Bild 4-3 Example of a polygon line calibration function after a 10-point calibration



Bild 4-4 Example of a parabola calibration function after a 10-point calibration

Determining the calibration function

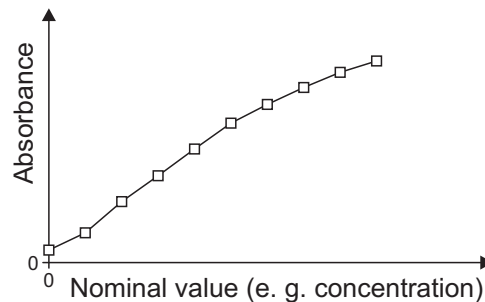
You have the following options to create a method:

- **Measure and store:**

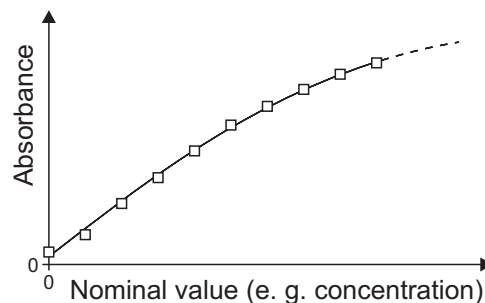
Carry out a series of measurements with the following sample solutions while at the same the photometer takes over the values:

- Blank sample to determine the reagent blank value (with deionized water instead of sample, see section 4.5.9)
- at least one, up to ten standard solutions in different concentrations.

The photometer stores the nominal value/absorbance value pairs of the individual measurements and determines the resultant characteristics of the calibration. When doing so, you can select the following line types: *Polygon line, Straight line or Parabola.*

- **Enter as value pairs:**

Entry of the value pairs, Nominal value (concentration) / Measured absorbance of an already available test series with the following sample solutions:

- Blank sample to determine the reagent blank value (with deionized water instead of sample, see section 4.5.9)
- at least one, up to ten standard solutions in different concentrations.

Based on the entered value pairs, the photometer determines the characteristics for the calibration. When doing so, you can select the following line types: *Polygon line, Straight line or Parabola.*

- **Enter a function:**

Entry of a function to calculate the concentration from the absorbance (reverse calibration function). You can enter on the photometer the coefficients of a polynomial equation of the following type:

$$c = a_0 + a_1 \cdot A + a_2 \cdot A^2 + a_3 \cdot A^3 + a_4 \cdot A^4 + a_5 \cdot A^5$$

with:

c	Measurement result, e.g. concentration
a ₀ to a ₅	Coefficients (input range 0.000 to 1000,000)
A	Absorbance



Note

Entering the formula is especially simple if you measure with a commercial test set for which the manufacturer has given the value for the coefficient a₁. It is often called the "Factor" and corresponds to the reciprocal value of the slope of the straight line of the calibration function.

If a linear function (straight line) should be entered, it is necessary to enter the coefficients a₀ and a₁ to receive correct measured values.

If the exact value for a_0 is not known at the time the formula is entered, it is sufficient to enter the coefficient a_1 . In this case, the *User-defined blank value* function (in the *Concentration / Setup* menu) has to be activated to measure with this method.

Prior to measuring with this method, a blank value measurement has to be carried out in this case. This procedure determines the value for a_0 , which then replaces the value from the programming of the method.

If the *User-defined blank value* function is not activated, the photometer uses the value zero for the coefficient a_0 .

**More information on
the entry of the
formula
(determination of
coefficients)**

**Linear
function**

If the value for a_1 (slope of the reverse calibration function) is unknown, you can very simply program the method in the photometer by measuring/storing or entering the value pairs (see above).

For entry as a formula, you can determine the coefficients of the reverse calibration function by linear regression. When doing so, the concentration has to be on the Y axis and the absorbance on the X axis.

In the case of a linear function, the coefficients of the reverse calibration function can also be determined from the determined reagent blank value and the slope (m) of the calibration function (Y axis = absorbance, X axis = concentration). Proceed as described below.

Explanation of the coefficients of the formula:

- $a_0 = - E_0 \cdot a_1$
[E_0 = reagent blank value
(absorbance at concentration 0)]
- $a_1 = 1/m$
Reverse value of the slope of the calibration
function
(often referred to as "Factor")
 m = slope of the calibration function
- a_2, a_3, a_4, a_5 = further coefficients
(when entering a linear function: zero)

**Nonlinear
function**

The coefficients of the reverse calibration function are determined by multiple regression. When doing so, the concentration has to be on the Y axis and the absorbance on the X axis.

Further method data	Input field	Possible entries
	<i>Number*</i>	1001 ... 1100
	<i>Designation</i>	Any name (max. 18 characters)
	<i>Version</i>	Any version designation (max. 18 characters)
	<i>Wavelength*</i>	Freely selectable (in nm)
	<i>Cell*</i>	16 (round), 10, 20 or 50 mm
	<i>Citation form</i>	e.g. PO4-P (max. 18 characters)
	<i>Unit**</i>	e.g. mg/l (max. 18 characters)
	<i>Resolution*</i>	0.001, 0.01, 0.1 or 1
	Lower and upper limit of the measuring range *	Any value between zero and the highest concentration of the used standard solutions
	Timer 0 to 3	Up to four analysis timers freely adjustable
	<i>AQA2 target value</i>	Any value within the measuring range
	<i>AQA2 tolerance</i>	Any

* necessary inputs

** default: mg/l

How to program user-defined methods

```
<HOME>
Concentration
├─ [Setup]
├─ New method
```

Edit method	04/16/07 9:52
Number	1001
Designation	Nitrite
Version	01
Wavelength	525
Cell	10 mm
Citation form	NO2-N
Unit	mg/l
Resolution	0.001
Calibration curve	Measure standard solutions
Method list	Delete
	Next

1 Enter the general method data here. The next available method number is already entered as the number.

You have the following options when filling out the input fields:

- Fill out all empty input fields one after the other
- Using *[Method list]*, select an already existing method as a model, give it a new method number and adjust the entries
- Using *[Method list]*, select an existing method in order to change it (without changing the number).
- You can delete the method completely with *[Delete]*.

2 Select the menu item, *Calibration curve*. Select the method for the determination of the calibration line. The following variants can be selected:

- *Measure standard solutions*
- *Enter value pairs*
- *Enter formula*

3 Using *[Next]*, accept all entries on the page and switch to the next page.



Note

During the following proceeding, you can return to the previous page at any time with *[Back]*, e. g. if you want to correct entries, add further value pairs or eliminate outliers.

**Variant 1:
Measure standard
solutions**

Edit method	04/16/07 9:52
Standard ID	[REDACTED]
Standard manufacturer	
Back	Next

- 1 Select and confirm *Measure standard solutions*.
- 2 Enter and confirm details of the standard solutions (optional).
- 3 Using *[Next]*, accept all entries on the page and switch to the next page.

Edit method	04/16/07 9:52		
	Target value Absorbance		
E0	0.000 [REDACTED]		
1			
Back	Add	Delete	Next

The table for the measurement of standard solutions pops up.

In the first two lines of the table, the two value pairs (measuring points) that are at least required for a calibration are already prepared (reagent blank value E0 and any further nominal value).

Edit method	04/16/07 9:52		
	Target value Absorbance		
E0	0.000		
1	0.300		
2	0.600		
3	1.000		
Back	Add	Delete	Next

- 4 Create further values pairs with *[Add]* as necessary.
- 5 In the *Target value* column, enter the nominal values of the individual standard solutions.

You can delete a highlighted value pair with *[Delete]*.

Edit method	04/16/07 9:52		
	Target value Absorbance		
E0	0.000 [REDACTED]		
1	0.300		
2	0.600		
3	1.000		
Back	Add	Delete	Next

Measuring the standard solutions:

- 6 Using the arrow keys *<▲>**<▼>* and *<◀>**<▶>*, navigate to the relevant input field in the *Absorbance* column and press *<START·ENTER>*.

Absorbance E0		04/16/07 9:52	
To start measurement, insert cell or press <Start/Enter>			
525 nm		16 mm	

The measurement display appears.

- 7 Insert the cell with the respective standard.

The absorbance is measured. The result of the first single measurement is displayed.

Absorbance E0		04/16/07 9:52	
Last measured absorbance 0.009 Median 0.009 (1 Measurement(s))			
525 nm		16 mm	
Next meas.	Discard		Apply

- 8 If necessary, carry out further single measurements for the formation of the median with *[Next meas.]* or discard the last single measurement with *[Discard]*.
- 9 To accept the median value, press *[Apply]*.



Note

If the zero standard concentration (reagent blank value E0) is not measured and stored, the photometer calculates the calibration line without this value. If the *User-defined blank value* function (in the *Concentration / Setup* menu) is activated for measuring with this method, the value for a0 is determined and replaces the calculated axis intercept from the programming of the method.

Edit method		04/16/07 9:52	
	Target value	Absorbance	
E0	0.000	0.009	
1	0.300	0.664	
2	0.600	1.292	
3	1.000	2.178	
Back	Add	Delete	Next

- 10 Repeat the steps 6 to 9 until all input fields in the *Absorbance* column are filled out.
- 11 Using *[Next]*, accept all entries on the page and switch to the next page.

The value pairs are displayed in a diagram (standard: Polygon line).

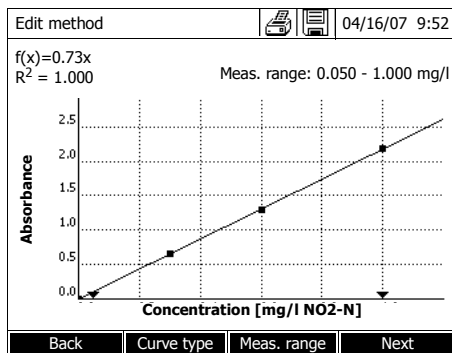

The related formula $f(x)$ and correlation coefficient R^2 are displayed above the diagram.

12 If required, select a different line type for the line adjustment with *[Curve type]*.

- Polygon line
- Straight line
- Parabola

13 If required, enter different measured value limits with *[Meas. range]*.

- Lower limit
- Upper limit

14 Using *[Next]*, complete the editing of the calibration line and proceed to the next page.

The timers and AQA2 data linked to the method are displayed.

Edit method		04/16/07 9:52
Timer 0		00:00:00
Timer 1		00:00:00
Timer 2		00:00:00
Timer 3		00:00:00
AQA2 target value		1.00 mg/l
AQA2 tolerance		0.10 mg/l

Back Complete

15 If necessary, enter intervals for up to 4 timers.

16 If necessary, enter the *AQA2 target value* and *AQA2 tolerance*.

17 Complete the programming of the method with *[Complete]*.

The method is programmed and selected for measuring.

**Variant 2:
Enter value pairs**

Unlike variant 1, the fields of the *Absorbance* column are filled out manually here. Accordingly, the steps 6 to 10 are not applicable here. Apart from that, the proceeding is identical to variant 1.

**Variant 3:
Enter formula**

Edit method	16.04.07 9:52
c = a0 + a1·A + a2·A ² + a3·A ³ + a4·A ⁴ + a5·A ⁵	
a0	0.605
a1	2
a2	
a3	
a4	
a5	
Lower limit of measuring range	1,000 mg/l
Upper limit of measuring range	3.000 mg/l
Method list	Delete
	Next

- 1 Select and confirm *Enter formula*.
Input fields for the coefficients (a0 ... a5) of the formula are displayed.
- 2 Enter and confirm the factors.
If no value is entered for a coefficient the photometer automatically uses the value 0.



Note

Entering the formula is especially simple if you measure with a commercial test set for which the manufacturer has given the value for the coefficient a1. It is often called the "Factor" and corresponds to the reciprocal value of the slope of the straight line of the calibration function.

If a linear function (straight line) should be entered, it is necessary to enter the coefficients a0 and a1 to receive correct measured values.

If the exact value for a0 is not known at the time the formula is entered, it is sufficient to enter the coefficient a1. In this case, the *User-defined blank value* function (in the *Concentration / Setup* menu) has to be activated to measure with this method. Prior to measuring with this method, a blank value measurement has to be carried out in this case. During this procedure the value for a0 is determined and replaces the previous value.

- 3 Enter and confirm the measuring range limits.
- 4 Complete the entering of the formula with *[Next]*.

The timers and AQA2 data linked to the method are displayed.

Edit method	04/16/07 9:52
Timer 0	00:00:00
Timer 1	00:00:00
Timer 2	00:00:00
Timer 3	00:00:00
AQA2 target value	2.000 mg/l
AQA2 tolerance	0.200 mg/l
Back	Complete

- 5 If necessary, enter intervals for up to 4 timers.
- 6 If necessary, enter the *AQA2 target value* and *AQA2 tolerance*.
- 7 Complete the programming of the method with *[Complete]*.
The method is programmed and selected for measuring.

4.5.12 The IQ LabLink procedure

The IQ-LabLink procedure enables the secure data exchange between the sensors of the IQ SENSOR NET online measuring system and a photometer (such as the spectroFlex series) with the aid of a commercial USB memory device.

During the matrix adjustment of the sensor, the measurement data of the IQ SENSOR NET sensor are adjusted to the photometrically determined reference data.

Previously, the reference data had to be entered manually during the matrix adjustment. With the aid of the IQ-LabLink procedure, the reference data can now be directly transferred to the IQ SENSOR NET sensors by means of a USB memory device, without manual input and with no risk of confusion.

System requirement for the IQ-LabLink procedure

- ⊕ IQ SENSOR NET:
 - Terminal/controller with USB-A interface and software for the IQ-LabLink procedure (e.g. MIQ/TC 2020 XT)
 - Online sensor with software for the IQ-LabLink procedure (e.g. VARiON®*Plus* 700 IQ)
- Photometer:
 - Photometer with software for the IQ-LabLink procedure (e.g. spectroFlex series)

Course of the IQ-LabLink procedure

Step 1 on the IQ SENSOR NET terminal:

Automatic creation of a job file on the USB memory device with current sensor values, parameters, designation of the measuring location and automatic allocation of a job reference number for clear identification

Step 2 on the photometer:

Automatic recognition of the job files, menu-guided measurement of all required parameters, storage of the determined data in the job file

Step 3 on the IQ SENSOR NET terminal:

Automatic recognition of the job files, complete reading of all data required for the matrix adjustment on keypressing

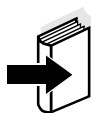

Note

Carrying out the matrix adjustment of an online sensor with the IQ-LabLink procedure requires operating steps on both instruments: IQ SENSOR NET system and spectroFlex photometer.

The detailed description of the cross instrument operating steps for the matrix adjustment with the IQ-LabLink procedure on the IQ SENSOR NET and the photometer is given in an additional operating manual. This operating manual can be downloaded from the Internet under www.wtw.com.

4.6 Measuring the Absorbance / % Transmission

4.6.1 General information

The absorbance or transmission respectively is measured without the use of any methods or profiles. All settings are configured during measurement.

Measuring against the Reference absorbance

The absorbance or transmission can alternatively be measured against the absorbance of the zero adjustment or against a *Reference absorbance* determined by yourself (see section 4.6.3 MEASURING AGAINST THE REFERENCE ABSORBANCE).

4.6.2 Measuring the absorbance or transmission

<HOME>
Absorbance / % Transmission

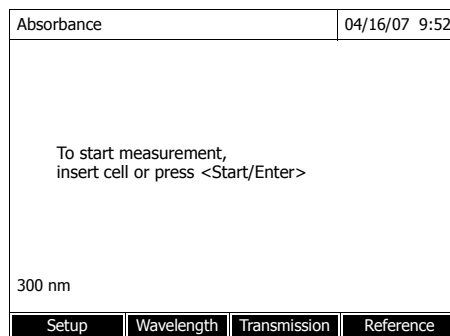

The settings of the last measurement are active.

- 1 Using *[Wavelength]*, change the wavelength as necessary.
- 2 Using *[Absorbance]* <-> *[Transmission]*, you can switch over between absorbance and transmission measurement.
- 3 If necessary, use or measure a reference measurement with *[Reference]* (see section 4.6.3).
- 4 Depending on the type, insert the cell as follows:

Round cell:

Insert the round cell in the round cell shaft so it touches the bottom.

If the inner turn-up lid is opened too wide, a message prompts you to close the inner turn-up lid.

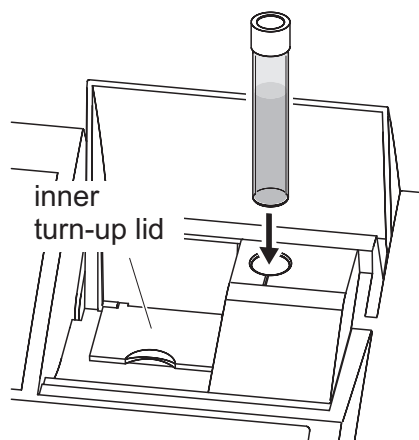

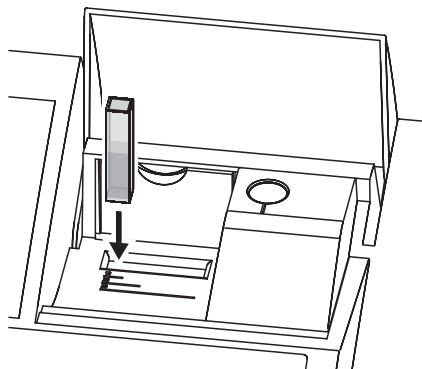

Rectangular cell:

Open the inner turn-up lid.

Insert the rectangular cell vertically so it touches the bottom and left edge of the cell shaft. The opaque sides of the rectangular cell must point to the front and back.

The photometer has an external light recognition. If there is too much external light, a message prompts you to close the cell shaft cover.

The photometer starts measuring automatically.

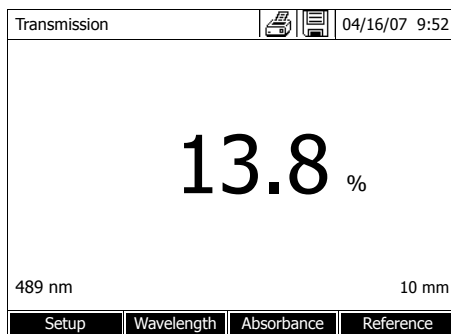
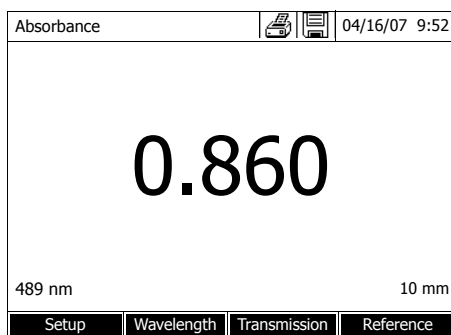

- 5 Using [Absorbance] <--> [Transmission], switch over the display from Absorbance to Transmission or vice versa.

4.6.3 Measuring against the Reference absorbance

Each time the photometer is switched on, the absorbance or transmission is measured against the absorbance of the zero adjustment as a basis. You can, however, also determine a *Reference absorbance* and use it as the basis.

The *Reference absorbance* refers to the adjusted wavelength. The measured value remains stored until

- the photometer is switched off
- the cell type is changed
- the wavelength is changed
- a new reference value is measured
- it is deleted manually (*[Reference] / Delete*).
- the *Absorbance / % Transmission* measuring mode is exited

Single and multiple determination

The Reference absorbance can be determined with single or multiple determination. With multiple determination, the mean value is calculated as the median from the individual measured values.

Measuring the Reference absorbance

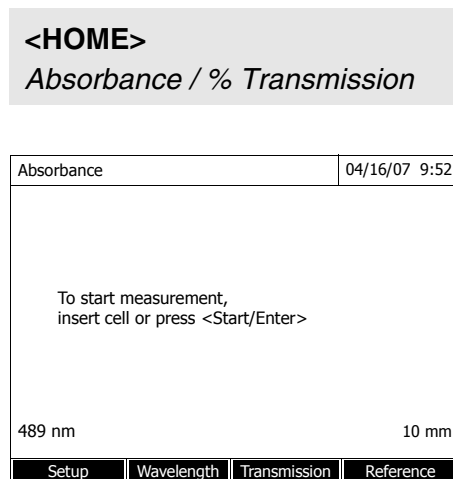

The settings of the last measurement are active.

- 1 Start the reference measurement with *[Reference]*.

If a value for the reference absorbance is already stored, it can be deleted or overwritten by a new reference measurement.

After the reference absorbance value has been deleted, the photometer measures against the absorbance of the zero adjustment.

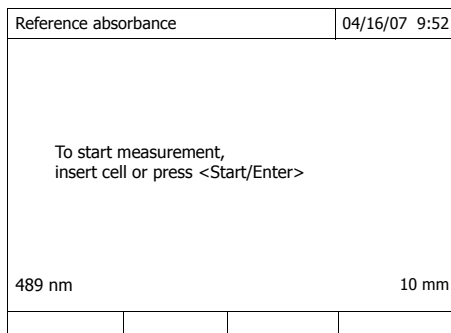

2 Insert the cell with the reference sample.

The first single measurement for the Reference absorbance is carried out.

The following data is displayed as the result:

- The measured absorbance from the (last) single measurement.
- The median from all single measurements carried out up to now.

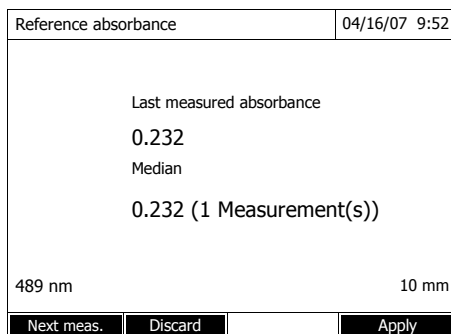

3 If necessary, carry out further single measurements for the formation of the median with *[Next meas.]* or discard the last single measurement with *[Discard]*.

4 To accept the median value, press *[Apply]*.

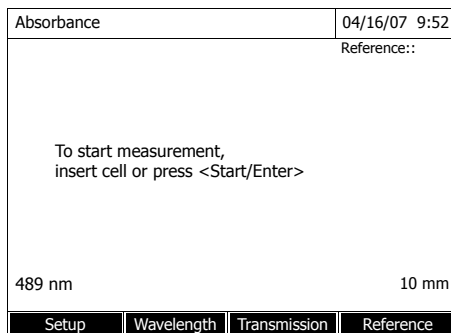

The photometer is ready to measure.

The reference absorbance is displayed in the top right corner during absorbance or transmission measurement.

4.7 Multi wavelengths methods

4.7.1 Basic information on Multi wavelengths measurements

The multi wavelength function of the photoLab® 6600 UV-VIS enables free calculation of any parameters from the absorbance values of several wavelengths. When doing so, two to ten wavelengths can be used.

Calculation takes place based on the following equation:

$$R = \frac{a0 + a1 \cdot A1 + a2 \cdot A2 + \dots + a10 \cdot A10}{b0 + b1 \cdot A1 + b2 \cdot A2 + \dots + b10 \cdot A10} \quad (\text{equation 1})$$

with:

<i>R</i>	<i>Result</i>
<i>a0 to a10; b0 to b10</i>	<i>Freely selectable coefficients (entry range 0.000 to 1000,000)</i>
<i>A1 to A10</i>	<i>Measured absorbance at the individual wavelengths 1 to 10</i>

The wavelengths 1 to 10 can be freely selected within the measuring range.

Example: Protein determination according to Warburg-Christian

Protein determination according to Warburg-Christian is based on measurement of the optical density (=absorbance) at 260 and 280 nm in a 10 mm cell. From this the protein content is calculated as follows:

$$c_{\text{Protein}} [\text{mg} / \text{ml}] = 1,55 \cdot A(280 \text{ nm}) - 0,76 \cdot A(260 \text{ nm}) \quad (\text{equation 2})$$

To convert the basic equation (1) into equation (2), the coefficients are set to the following values:

<i>a0 = 0</i>	<i>b0 = 1</i>	
<i>a1 = 1,55</i>	<i>b1 = 0</i>	<i>a1 = A(280 nm)</i>
<i>A2 = -0,76</i>	<i>b2 = 0</i>	<i>A2 = A(260 nm)</i>
<i>A3 = 0</i>	<i>b3 = 0</i>	<i>A3 = Not used</i>
<i>A4 = 0</i>	<i>b4 = 0</i>	<i>A4 = Not used</i>
<i>a5 = 0</i>	<i>b5 = 0</i>	<i>a5 = Not used</i>
<i>a6 = 0</i>	<i>b6 = 0</i>	<i>a6 = Not used</i>
<i>a7 = 0</i>	<i>b7 = 0</i>	<i>a7 = Not used</i>
<i>a8 = 0</i>	<i>b8 = 0</i>	<i>a8 = Not used</i>
<i>a9 = 0</i>	<i>b9 = 0</i>	<i>a9 = Not used</i>
<i>a10 = 0</i>	<i>b10 = 0</i>	<i>a10 = Not used</i>

All absorbances are measured in one step and the result is calculated according to the equation.

4.7.2 Programming / modifying Multi wavelengths methods



Note

For multi wavelength methods, the method numbers 2001 to 2050 can be used.

In the delivery condition, one method is stored for demonstration purposes.

```
<HOME>
Multi wavelengths
- [Setup]
- Edit method
```

Edit method (1 of 6)		04/16/07 9:52
Number		2001
Name		PROT
Version		1.0
Citation form		Protein
Unit		mg/ml
Resolution		0.1
Cell		10 mm
Method list		Delete
		Next

1 Page 1 of 6:

Enter the general method data here. The next available method number is already entered as the number.

You have the following options when filling out the input fields:

- Fill out all empty input fields one after the other
- Using *[Method list]*, select an already existing method as a model, give it a new method number and adjust the entries
- Using *[Method list]*, select an existing method in order to change it (without changing the number).
- You can delete the method completely with *[Delete]*.

2 Using *[Next]*, accept all entries on the page and switch to the next page.

Edit method (2 of 6)		04/16/07 9:52	
Wavelength 1		280 nm	
Wavelength 2		260 nm	
Back		Add	Delete Next

3 Page 2 of 6:
Add another wavelength with *[Add]*.

Delete the last wavelength with *[Delete]*.

4 Using *[Next]*, accept all entries on the page and switch to the next page.

Edit method (3 of 6)		04/16/07 9:52	
$R = \frac{a_0 + a_1 * A_1 + a_2 * A_2 + \dots + a_{10} * A_{10}}{b_0 + b_1 * A_1 + b_2 * A_2 + \dots + b_{10} * A_{10}}$			
a0	0.000	a6	0.000
a1	1.550	a7	0.000
a2	-0.757	a8	0.000
a3	0.000	a9	0.000
a4	0.000	a10	0.000
a5			
Back			Next

5 Page 3 of 6:
Enter the coefficients for the basic equation (more detailed information of the basic equation, see section 4.7.1).

6 Using *[Next]*, accept all entries on the page and switch to the next page.

Edit method (4 of 6)		04/16/07 9:52	
$R = \frac{a_0 + a_1 * A_1 + a_2 * A_2 + \dots + a_{10} * A_{10}}{b_0 + b_1 * A_1 + b_2 * A_2 + \dots + b_{10} * A_{10}}$			
b0	1.000	b6	0.000
b1	0.000	b7	0.000
b2	0.000	b8	0.000
b3	0.000	b9	0.000
b4	0.000	b10	0.000
b5			
Back			Next

7 Page 4 of 6:
Enter the coefficients for the basic equation (more detailed information of the basic equation, see section 4.7.1).

8 Using *[Next]*, accept all entries on the page and switch to the next page.

Edit method (5 of 6)		04/16/07 9:52	
Number:		2002	
Name:		PROT	
Version:		1.0	
Citation form:		Protein	
Unit:		mg/ml	
Resolution:		0.001	
Cell:		10 mm	
Back			Next

9 Page 5 of 6:
The data is displayed once again as a summary.

Using *[Back]*, you can correct wrong data on the previous pages.

Using *[Next]*, accept all entries on the page and switch to the next page.

The method is programmed and selected.

Edit method (6 of 6)	04/16/07 9:52
$R = \frac{1.550 * A(280 \text{ nm}) - 0.757 * A(260 \text{ nm})}{1.000}$	
Back	Complete

10 Page 6 of 6:

The basic equation is displayed (for more information on the basic equation see section 4.7.1).

11 Complete the editing with *[Complete]*.

4.7.3 Selecting a Multi wavelengths method

To select a method for Multi wavelengths measurements, proceed as follows:

```
<HOME>
Multi wavelengths
├─ [Method list]
```

Select method (all)		04/16/07 9:52	
<input type="text"/>			
2001	Protein	Protein	mmol/l
2002	DNA purity		
Last used			

The list of methods is displayed. The methods are ordered according to the method number.

Select the method:

- 1 Select the required method with **<▲><▼>**. The active selection is displayed in reverse video.
- 2 Accept the selection with **<START-ENTER>**.

The photometer is ready to measure.

Narrowing down the method list

If the list is very long, you can narrow down the method list and thus make the search easier as follows:

- Using *[Last used]*, you can restrict the method list to the ten methods last used.
- With the search function you can search certain character strings in the list. The search takes place as a full-text search of the entire list contents. Thus you can search for a method number or certain citation form.

Search function

Select method (last used)		04/16/07 9:52	
<input type="text" value="Pro_"/>			
2001	Protein	Protein	mmol/l
All methods			

Search for a character string:

Enter the character string to be searched for in the search window with **<A...9>**.

The list appearing below shows all hits containing the character string. The hit list is updated with each character that is entered.



Note

Note the case sensitivity when searching.

4.7.4 Carrying out Multi wavelengths measurements

<HOME>
Multi wavelengths

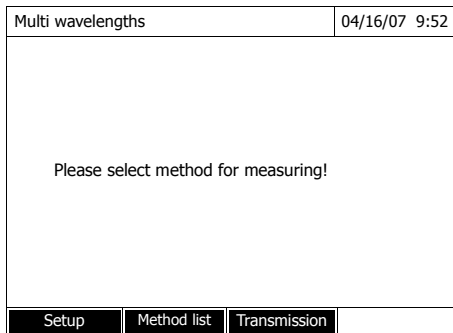

1 Select the required method with [Method list] (see section 4.7.3).

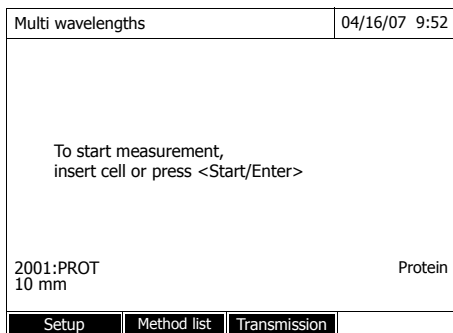

The photometer is ready to measure after the method has been selected.

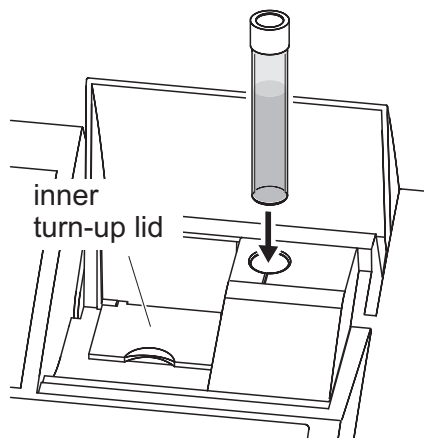

2 Depending on the type, insert the cell as follows:

Round cell:

Insert the round cell in the round cell shaft so it touches the bottom.

If the inner turn-up lid is opened too wide, a message prompts you to close the inner turn-up lid.

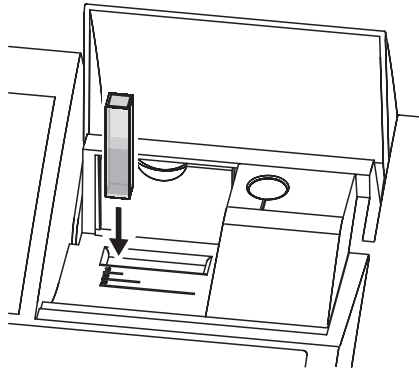

Rectangular cell:

Open the inner turn-up lid.

Insert the rectangular cell vertically so it touches the bottom and left edge of the cell shaft. The opaque sides of the rectangular cell must point to the front and back.

The photometer has an external light recognition. If there is too much external light, a message prompts you to close the cell shaft cover.

If necessary, carry out a zero measurement.

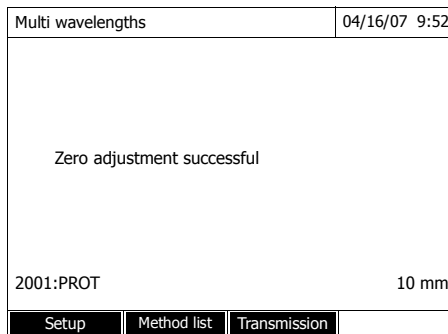

The photometer is ready to measure.

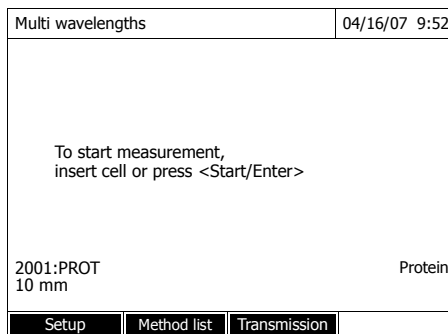

The photometer starts measuring automatically.

If necessary, switch over to transmission display (%) with [Transmission].

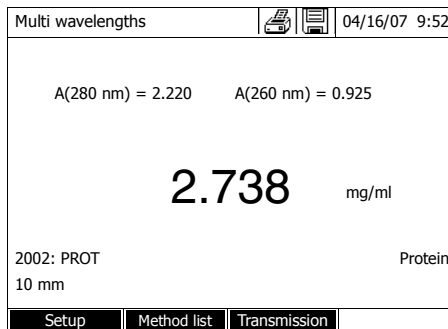

4.8 Spectrum

4.8.1 General information

With the Spectrum function, the absorbance or *Transmission* in dependency of the wavelength is measured and recorded. The wavelength range can be freely selected within the measuring range of the photometer. The increment is 1 nm.

A spectrum is recorded without using any methods or profiles. All settings are configured during measurement.

Baseline A baseline has to be recorded before a spectrum is recorded. The baseline has to cover at least the wavelength range of the spectrum to be recorded. Once the baseline is measured, it remains stored in the photometer until

- a new baseline is recorded
- the *Spectrum* mode is exited or the photometer is switched off

Settings You can record a spectrum with standard settings without opening the setting window.

The following settings are possible for a spectrum:

Input field	Possible entries
<i>Wavelength start</i>	190* ... 1100 nm
<i>Wavelength stop</i>	190 ... 1100* nm
<i>Mode</i>	<i>Absorbance*</i> or <i>Transmission</i>
<i>Smoothing</i>	<i>Yes*</i> or <i>No</i>
<i>Scaling</i>	<i>Auto*</i> or <i>Manual</i>
<i>Scaling: Auto*</i>	During measurement, the instrument adjusts the axis scaling (minimum and maximum value of the axis) to the measured values. The entire curve is always visible.
<i>Scaling: Manual</i> <i>Y-axis min</i> <i>Y-axis max</i>	The axis scaling (minimum and maximum value of the axis) is set manually.

* default setting



Note

You can store the settings as profile with [*Save*].
You can load a stored profile with [*Open*].
Profiles have the file extension "*.profil".

4.8.2 Recording the Spectrum

<HOME>
Spectrum

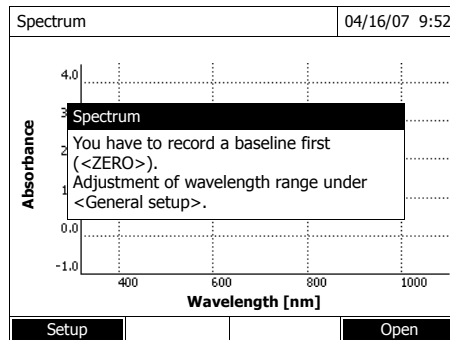

A message containing operating instructions is displayed.

- 1 Open the setting menu with [Setup].
- 2 Select the start and end point of the spectrum to be recorded and the mode (Absorbance or Transmission).
- 3 Accept all entries with [Apply].

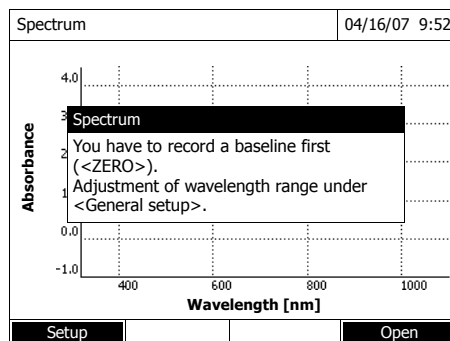
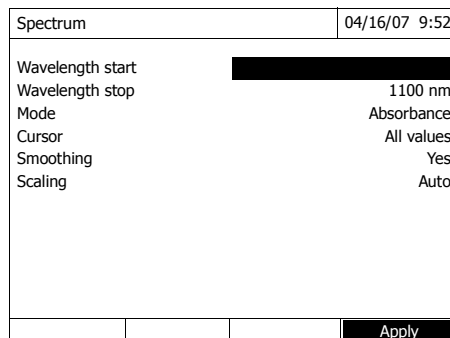

A message containing operating instructions is displayed.

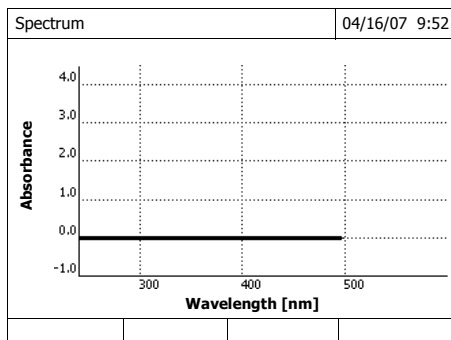

Recording the baseline:

- 4 Press the **<ZERO-BLANK>** key.
The photometer records the baseline.
- 5 Wait until the baseline is completely recorded.

The photometer is ready to measure after the baseline has been recorded.

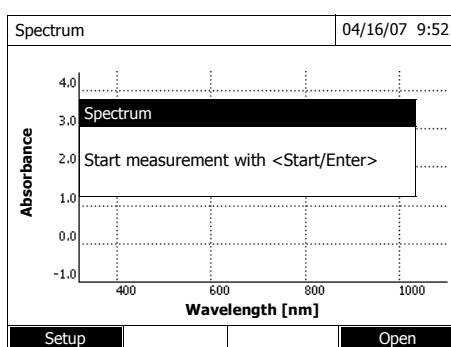

Recording the spectrum:

- 6 Depending on the type, insert the cell as follows:
Round cell:
Insert the round cell in the round cell shaft so it touches the bottom.
- 7 Close the inner turn-up lid.
- 8 Start the measurement with **<START-ENTER>**.

After the spectrum has been recorded, the following message appears: *Recording of spectrum is completed.*

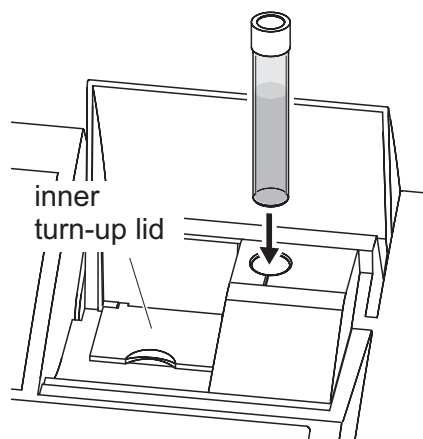

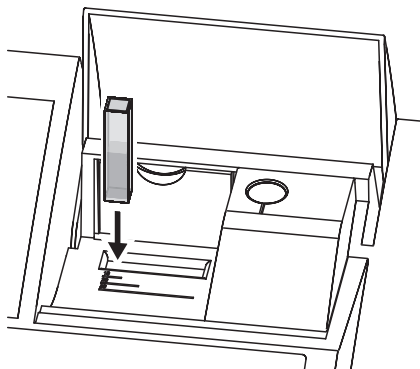

Rectangular cell:

Open the inner turn-up lid.

Insert the rectangular cell vertically so it touches the bottom and left edge of the cell shaft. The opaque sides of the rectangular cell must point to the front and back.

- 9 Close the cell shaft cover.
- 10 Start the measurement with **<START·ENTER>**.

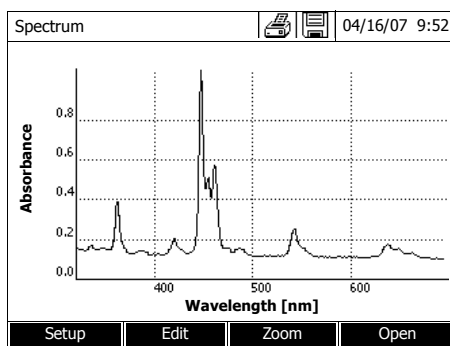

- 11 Wait until the spectrum is completely recorded.

At the end of the recording the following message appears:
Recording of spectrum is completed.

- 12 Confirm the message with **<START·ENTER>**.

Cursor information

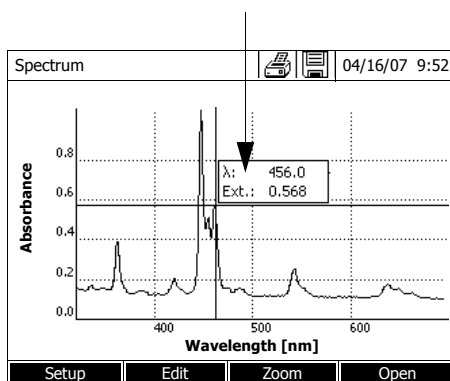

The cursor appears at the absolute maximum of the spectrum.

- 13 You have the following options:
 - Immediately edit the spectrum (see section 4.8.3)
 - With **<PRINT>**, you can output the spectrum to a connected printer as a graphic.
 - You can save the spectrum as a *.csv file with **<STORE>**. As the storage location, you can select the photometer (*Internal DataB folder*) or a USB memory device connected to the USB-A connection (*USB memory*). Stored spectra can be recalled and edited at any time (see section 4.8.3).

4.8.3 Loading/editing a spectrum

A spectrum can be edited immediately after measurement. Stored spectra can be loaded and edited as well.

The following tools are available for editing:

- Cursor function for incremental moving along the curve with indication of the x and y values
- Zoom function to scale up a section
- Mathematical functions for various evaluating and calculating operations. The functions are described from page 86.

Loading a stored spectrum

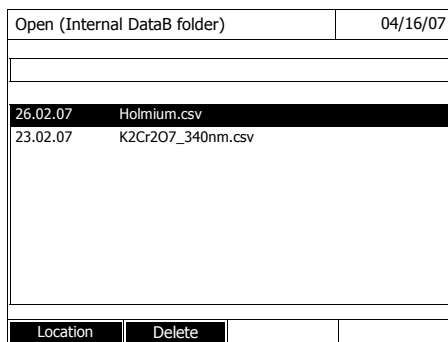

The list with the spectra stored in the exchange memory is displayed.

1 If necessary, you can select a different memory location for the spectrum with *[Location]* (USB memory device at the USB-A connection).

2 Select the required spectrum.

The original view of the curve is displayed.

Cursor

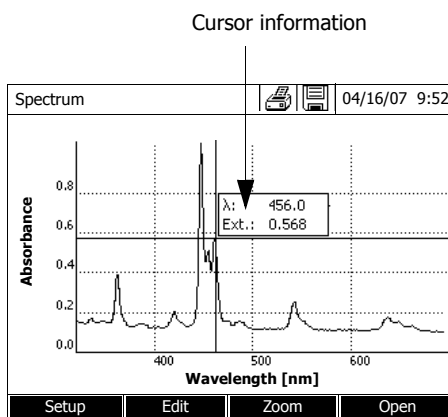

The cursor consists of a horizontal and vertical line that cross each other on a point of the curve. A box names the x and y values of the point of the curve.

Move the cursor along the x axis (wavelength) with *<<>>*. You can scan and evaluate the curve point after point.

Zoom

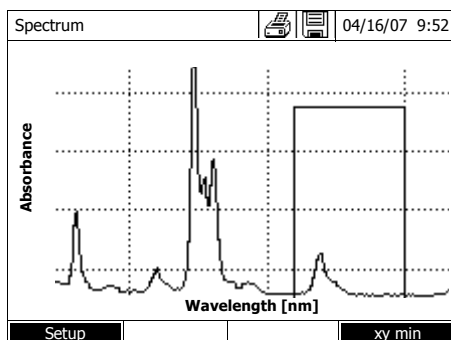

1 Press [Zoom].

The zoom window appears. The bottom left corner of the zoom window is marked by a small black square.

- You can return to the original view of the spectrum with [Original] at any time.

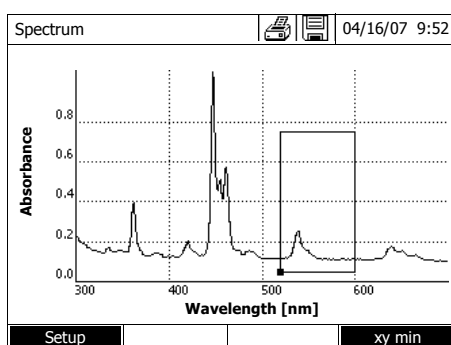

2 Adjusting the zoom window:

- Define the bottom left corner of the zoom window with <◀><▶> and <▲><▼>.

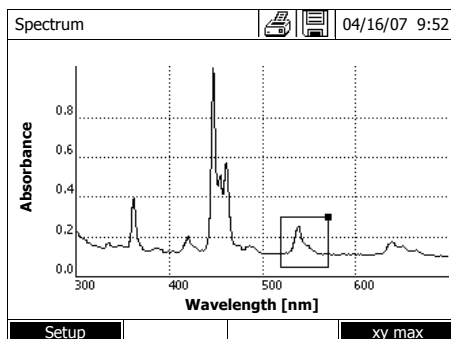

- Use [xy max] to mark the top right corner of the zoom window (small black square).
- Define the top right corner of the zoom window with <◀><▶> and <▲><▼>.

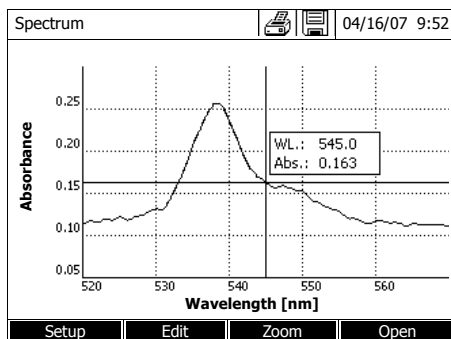

3 Scaling up the zoom window:

- Press the <START·ENTER> key. The zoom window is scaled up on the entire diagram area.

Leaving the zoom view:

- You can return to the original view of the spectrum with <ESC> at any time.

- Edit** Open the selection of mathematical functions with *[Edit]*:
- *Extreme values (zoomed area)*
Highlights the extreme values (minimum and maximum values) of the displayed spectrum.
 - *Mark points*
Opens an edit mode where you can highlight individual points of the spectrum.
With the *[Mark]* function key you can highlight individual points. The wavelength and measured value are displayed at the highlighted point.
With the *[Delete]* function key you can remove individual points.
 - *Delete all marks*
Erases all highlighted points in the spectrum.
 - *Original*
Displays the original, unedited spectrum.
 - *Integral*
Calculates the area between the zero line and curve within a freely selectable wavelength interval [X1,X2].
 - *Derivative*
Calculates the derivative of the total spectrum. To calculate the second and third derivative, the function can be carried out several times.
 - *Compare spectrum*
Loads a second spectrum into the same diagram for direct comparison.
 - *Add spectrum*
Adds a stored spectrum to the current spectrum.
 - *Subtract spectrum*
Subtracts a stored spectrum from the current spectrum.
 - *Divide spectrum (ratio)*
Divides the absorbance or % transmission values of the current spectrum by the values of a stored spectrum
 - *Add fixed value*
Adds a constant absorbance or % transmission value to the current spectrum.
 - *Multiply fixed value*
Multiplies the absorbance or % transmission values of the current spectrum by a constant value.

**Note**

The addition, subtraction and division of two spectra always applies to the common wavelength range of both spectra only.

4.8.4 Saving / exporting a spectrum

The saving of a spectrum saves both the edited and the original spectrum. Consequently, the original spectrum can be restored from each stored spectrum.

Saving

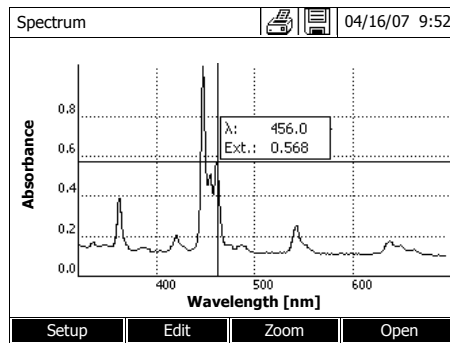

- 1 Record a spectrum (see section 4.8.2) or Load a stored spectrum (see section 4.8.3).
- 2 If necessary, connect a USB memory device to the USB-A interface.
- 3 Open the save dialog with **<STORE>**.
- 4 If necessary, change the storage location with *[Location]*:
Internal DataB folder:
Exchange folder in the instrument or
USB memory:
USB memory device connected at the USB-A connection.
- 5 If necessary, change the file name.
- 6 Save the file with **<START·ENTER>**.

Export to a PC Export a stored spectrum to a PC: see section 4.12.3

4.9 Kinetics

The Kinetics function enables the temporal tracing of the absorbance or transmission of a sample at a certain wavelength.

The photometer automatically calculates the slope between two adjacent measuring points from the available measurement data.

The catalytic activity can also be determined and displayed if required.

To record the kinetics, the photometer carries out single measurements at regular intervals (measuring interval) and stores the measured values as a time function.

All settings for a recording are administrated as a profile. Profiles can be created, stored, edited and deleted. Each measurement requires a respective profile.

4.9.1 Creating/editing profiles for kinetic records



Note

Profiles for kinetic records are stored under the numbers 4001 to 4020. In the delivery condition, a profile is stored for demonstration purposes.

A profile for a kinetic recording comprises the following data:

Input field	Possible entries
<i>Number</i> *	4001 ... 4020
<i>Name</i>	Any name (max. 18 characters)
<i>Mode</i> *	<i>Absorbance</i> or <i>Transmission</i>
<i>Wavelength</i> *	Freely selectable (in nm)
<i>Duration</i> *	Total duration in the format hh:mm:ss (hours:minutes:seconds)
<i>Interval</i> *	Measuring interval = time interval between two successive single measurements in the format hh:mm:ss (hours:minutes:seconds) Exception: With the setting, <i>Measurements/interval: Max/interval</i> the interval is defined differently (see below).
<i>Delay</i>	Time between the start of the recording and the start of the first single measurement
<i>Scaling</i>	<i>Auto</i> or <i>Manual</i>

Input field	Possible entries
<i>Scaling: Auto**</i>	During measurement, the instrument adjusts the axis scaling (minimum and maximum value of the axis) to the measured values. The entire curve is always visible.
<i>Scaling: Manual</i> <i>Y-axis min</i> <i>Y-axis max</i>	The axis scaling (minimum and maximum value of the axis) is set manually.
<i>Measurements/interval</i>	<i>1/interval</i> or <i>Max/interval</i> Here you define how many measurements are carried out per interval. This setting has an impact on the calculation of the slope of the individual intervals (see section 4.9.6).
<i>Catalytic activity</i>	<i>Yes</i> or <i>No</i> Here you determine whether the catalytic activity should be calculated. The catalytic activity is a measure for the amount of substance that is converted per time unit. To accelerate the substance conversion, a catalyst or enzyme (biological catalyst) is used in most cases.
<i>Catalytic activity: Yes</i> <i>Factor</i> <i>Unit</i> <i>Resolution</i>	The catalytic activity or enzymatic activity is calculated from the slope of the curve. <div style="border: 1px solid black; padding: 5px; width: fit-content; margin: 10px 0;">$\text{Cat. A.} = \text{mean value Slope } [\Delta/\text{min}] * \text{Factor}$</div> Here you can enter the value for <i>Factor</i> . The calculated value for the catalytic activity is displayed in the menu, <i>[Edit]/ Slope</i> , together with the unit and resolution selected here.

* necessary inputs

** default: *Auto*

Creating/editing a profile

```
<HOME>
Kinetics
  - [Setup]
    | Edit profile
```

Edit profile (1 of 2)		04/16/07 9:52
Number		4001
Name		NADH
Mode		Absorbance
Wavelength		340 nm
Duration		02:00:00
Interval		00:00:30
Delay		00:01:00
Scaling		Auto
Profile		Delete
		Next

1 Enter the data for the profile here. The next available profile number is already entered as the number.

You have the following options when filling out the input fields:

- Fill out all empty input fields one after the other
- Using *[Profile]*, select an already existing profile as a model, give it a new profile number and adjust the entries
- Using *[Profile]*, select an existing profile in order to change it (without changing the number).
- You can delete the profile completely with *[Delete]*.

2 With *[Next]* you can switch to further settings.

Edit profile (1 of 2)		04/16/07 9:52
Measurements/interval		1/interval
Katalytic activity		Yes
Factor		1.000
Unit		cat
Resolution		0.01
Back		Complete

3 Enter further data for the profile here.

4 Accept all entries with *[Complete]*.

The profile is created and selected. The photometer is ready to measure.

Note

The *Catalytic activity* function is only available if the Absorbance mode was selected.

4.9.2 Loading a profile for kinetic recording

To load a profile for kinetic recording, proceed as follows:



Select profile (all)		04/16/07 9:52	
<input type="text"/>			
4001	NADH	Absorbance	
4002	ADH	Absorbance	
Last used			

The list of profiles is displayed. The profiles are ordered according to the profile number.

Selecting a profile:

- 1 Select the required profile with **<▲><▼>**. The active selection is displayed in reverse video.
- 2 Accept the selection with **<START-ENTER>**.

The photometer is ready to measure.

Narrowing down the list of profiles

If the list is very long, you can narrow down the profile list and thus make the search easier as follows:

- Using *[Last used]*, you can restrict the profile list to the ten profiles last used.
- With the search function you can search certain character strings in the list. The search takes place as a full-text search of the entire list contents. Thus you can search for a profile number or name.

Search function

Select profile (last used)		04/16/07 9:52	
<input type="text" value="NA_"/>			
4001	NADH	Absorbance	
All profiles			

Search for a character string:

Enter the character string to be searched for in the search window with **<A...9>**.

The list appearing below shows all hits containing the character string. The hit list is updated with each character that is entered.



Note

Note the case sensitivity when searching.

4.9.3 Recording the Kinetics



Note

During the recording, the photometer cannot carry out any regular self-test or self-calibration (AutoCheck), because the recording would have to be interrupted for this. A warm-up time of at least two hours is required for the photometer to measure reliably during the recording.

<HOME>
Kinetics

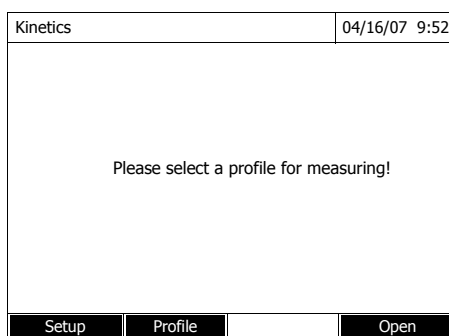

Note the warm-up time of at least 2 hours for kinetic recordings.

- 1 Select the required profile with *[Profile]* (see section 4.9.2).

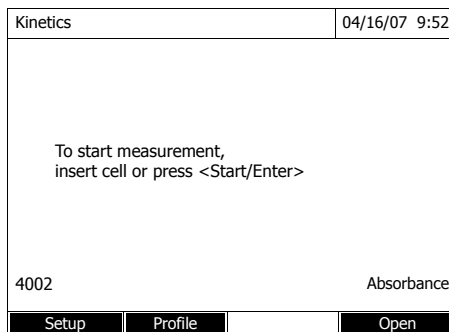

The photometer is ready to measure after the profile has been selected.

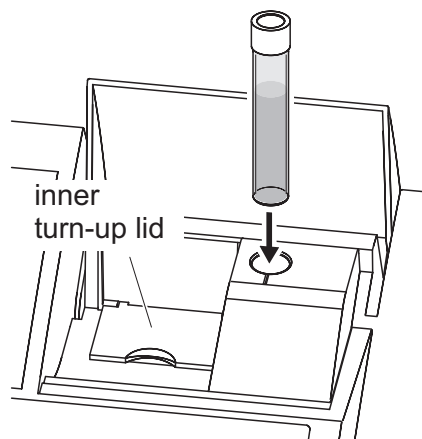

- 2 Depending on the type, insert the cell as follows:

Round cell:

Insert the round cell in the round cell shaft so it touches the bottom.

If the inner turn-up lid is opened too wide, a message prompts you to close the inner turn-up lid.

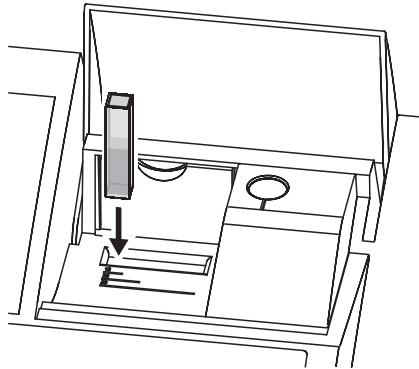

Rectangular cell:

Open the inner turn-up lid.

Insert the rectangular cell vertically so it touches the bottom and left edge of the cell shaft. The opaque sides of the rectangular cell must point to the front and back.

The photometer has an external light recognition. If there is too much external light, a message prompts you to close the cell shaft cover.

The photometer starts recording automatically.

3 Wait until the recording is finished.

Stopping the recording:

- Use *[Stop]* to terminate the recording prematurely. The curve recorded up to this point can be stored and edited (see section 4.9.6).
- Use **<ESC>** to completely cancel measurement. The curve recorded up to this point is discarded.

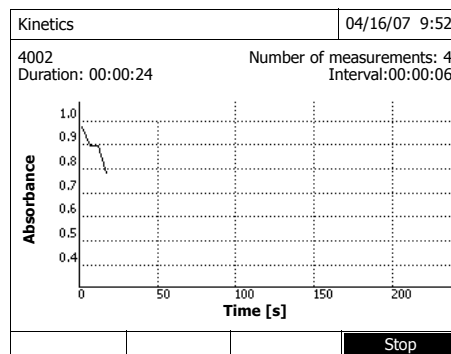

Cursor information

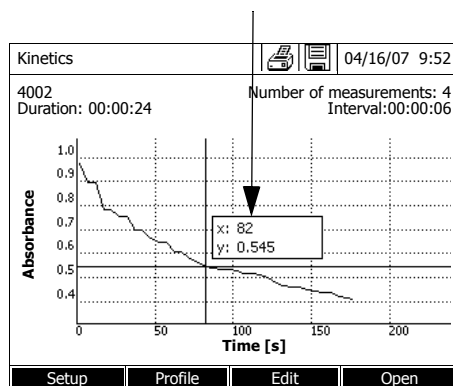

4 After the specified *Duration* has expired, the cursor appears.

You have the following options:

- You can move the cursor along the curve and have the measurement data for each point displayed (see section 4.9.6)
- With **<PRINT>**, you can output the kinetic curve to a connected printer as a graphic.
- You can store the kinetic curve with **<STORE>** (see section 4.9.4).
- Execute further functions to edit the kinetic record (see section 4.9.6)
- Close the kinetic record with **<ESC>**.

4.9.4 Saving / exporting a kinetic record

Saving

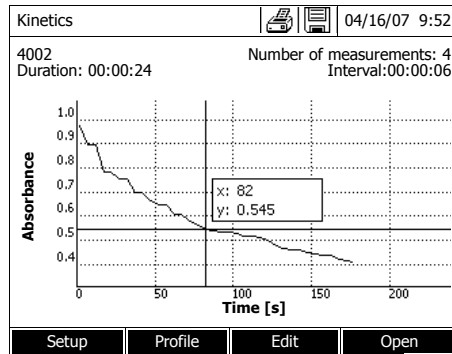

- 1 Carry out the kinetic recording (see section 4.9.3) or Load a stored kinetic record (see section 4.9.4).
- 2 If necessary, connect a USB memory device to the USB-A interface.
- 3 Open the save dialog with **<STORE>**.
- 4 If necessary, change the storage location with *[Location]*:
Internal DataB folder.
Exchange folder in the instrument or
USB memory:
USB memory device connected at the USB-A connection.
- 5 If necessary, change the file name.
- 6 Save the file with **<START·ENTER>**.

Export to a PC

Export a stored kinetic record to a PC: see section 4.12.3

4.9.5 Loading a kinetic record

You can load and view stored kinetic records.

Loading a stored Kinetics record

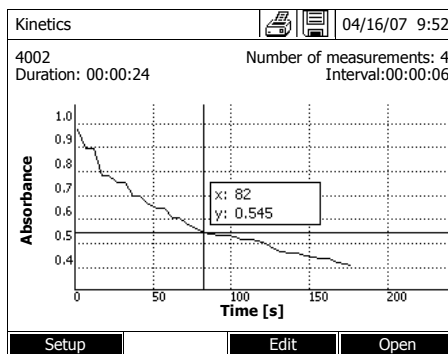
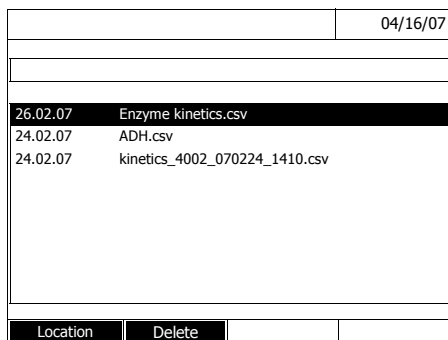
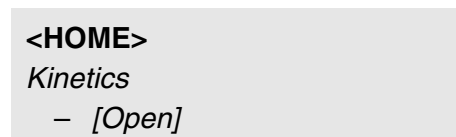

The list with the stored kinetic records is displayed (*Internal DataB folder*).

- 1 With [Location] select the memory location of the kinetic record (*Internal DataB folder* or *USB memory* for a USB memory device at the USB-A connection).
- 2 Select the required kinetic record.

The curve is loaded.

You have the following options:

- You can move the cursor along the curve and have the measurement data for each point displayed (see section 4.9.6)
- With <PRINT>, you can output the kinetic curve to a connected printer as a graphic.
- You can store the kinetic curve with <STORE> (see section 4.9.4).
- Execute further functions to edit the kinetic record (see section 4.9.6)
- Close the kinetic record with <ESC>.

4.9.6 Editing a kinetic record

The following functions are available for kinetic records:

- Moving along the curve with the cursor
- Displaying a list with the slopes of the curve for each interval
- Scaling the Y-axis of the diagram
- Combined display of two kinetic records in one graphic
- Display of the difference of two kinetic records

Cursor

Cursor information

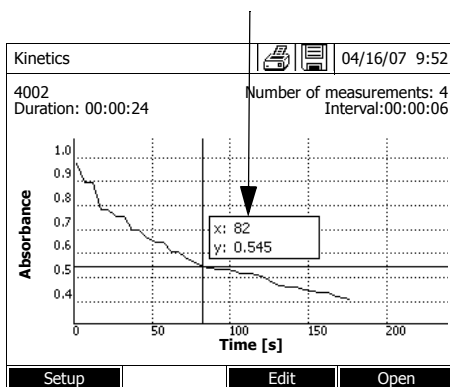

The cursor consists of a horizontal and vertical line that cross each other on a point of the curve. A box names the x and y values of the point of the curve.

Move the cursor along the x axis (time axis) with <◀><▶>. You can scan and evaluate the curve point after point.

Slope of the curve & catalytic activity

The function, *Slope* indicates the slope of the kinetic curve in the individual intercepts (intervals) of the curve.

An intercept corresponds to the *Interval* entered in the profile.

- 1 Indicate the slope of the kinetic curve in the individual intercepts (intervals) of the curve with *[Edit] / Slope*.

Interval	Slope (Δ/min)	Time
1	0.000	5 s
2	0.000	10 s
3	0.000	15 s
4	0.000	20 s
5	0.000	25 s
6	0.000	30 s

If the calculation of the catalytic activity was selected when the profile was created it is displayed here together with the slope.

**Note**

The *Slope* function is only available if the kinetic recording was done in the Absorbance mode.

The displayed slope for an interval is determined as follows, depending on the slope:

<i>Measurements/interval</i>	Slope
<i>1/interval</i>	Slope, converted to the interval, "1 minute"
<i>Max/interval</i>	Slope of the straight line determined by linear regression in an interval, converted to the interval, "1 minute"

Scaling of the Y-axis

You can manually determine the scaling of the Y-axis with *[Setup]/Scaling/Manual*.

Compare kinetics

For direct comparison, you can load a second kinetic record into the same diagram with *[Edit]/Compare kinetics*.

**Note**

The *Compare kinetics* function can only be carried out if both kinetic records were made in the Absorbance mode.

Subtract kinetics

You can subtract a stored kinetic record from the current kinetic record with *[Edit]/Subtract kinetics*.

**Note**

The *Subtract kinetics* can only be carried out if both kinetic records were made with the following settings:

- Mode: Absorbance
- Measurements/interval: 1/interval
- Equal interval

4.10 Timer

You can use the timers to remind you by an acoustic signal of a time interval that has expired.

The photometer has two types of timers:

- The *User defined timer* is a timer that can be freely assigned. The interval and name can be freely set. Only one freely assignable timer is available. It cannot be erased (see section 4.10.1).
- *Analysis timer* are timers permanently stored in the photometer. The names and intervals of the analysis timers are stored in the method data of a measuring method (*Concentration* mode). The number of available analysis timers corresponds to the number of reaction times prescribed in the analysis instructions of the programmed methods (see section 4.10.2).

The photometer administrates all timers in the timer overview.

The timer overview (the *Timer* menu) is opened with the <TIMER> key. The *Timer* menu can be opened in any operating situation. Operation of the timer does not disturb any other functions. The timer overview can be exited with the <ESC> key.

When the *Timer* menu is opened for the first time, only the user-defined timer is in the timer overview. You can include analysis timers into the list or remove them according to your requirements (see section 4.10.2).

The timer overview displays the status of each timer and, of a started timer, the remaining time of the specified time interval.

All timers are started manually.

As soon as one single timer has been started the timer symbol appears on the display in all operating modes.

When a timer has been started it is given the timer status, *Active*.

When the specified time interval has expired the timer status changes from *Active* to *Expired* and an acoustic signal sounds.

In the timer status *Expired* the acoustic signal sounds until the timer is stopped manually.

After the stop, the timer status changes to *Inactive* and the acoustic signal is switched off.

4.10.1 User defined timer

If you want to manually enter time intervals, use the *User defined timer* function.

<TIMER>

Timer		04/16/07 9:52
Designation	Time	Status
User defined timer	00:15:00	Inactiv
A6/25 - 1	00:15:00	Inactiv

Start Stop Edit Add

The *Timer* menu is open.

- 1 Highlight the *User defined timer*.
- 2 If necessary, change the name and time of the timer with *[Edit]*.
- 3 Start the highlighted timer with *[Start]*.

The status of the timer is *Active*. When the specified time interval has expired, an acoustic signal sounds and the status changes to *Expired*.

- 4 Stop the highlighted timer with *[Stop]*.

The status of the timer changes to *Inactive*. The acoustic signal is switched off.

4.10.2 Analysis timer

Between the individual steps of a measurement, reaction times often have to be observed. The length of the reaction time is defined in the relevant analysis instructions.

For all required reaction times, the analysis timers with the corresponding time intervals are stored in the instrument. The names of the analysis timers include the method name and a current number so several timers within a method can be distinguished from each other.

To be able to use an analysis timer for a method you have to load it in the timer overview first.

To do so, first select the required method and then add the available analysis timers to the timer overview so they can be started as necessary.

The timer overview always comprises the free timer and the selected analysis timers.

<TIMER>

Timer		04/16/07 9:52
Designation	Time	Status
User defined timer	00:15:00	Inactiv
A6/25 - 1	00:15:00	Inactiv
<div style="display: flex; justify-content: space-around; border-top: 1px solid black; border-bottom: 1px solid black;"> Start Stop Remove Add </div>		

- 1 Select the required method in the *Concentration* mode.

Manual selection of the method (see section 4.5.5).

- 2 Open the Timer menu.

The *Timer* menu is open.

- 3 If necessary, add a new timer to the list with *[Add]*.

Note:

The *[Add]* function key is only displayed if a method is selected for which analysis timers were programmed but are not yet displayed in the list of timers.

- 4 Highlight an analysis timer.
- 5 If necessary, remove the analysis timer from the list with *[Remove]*.
- 6 Start the highlighted timer with *[Start]*.

The status of the timer is *Active*. When the specified time interval has expired, an acoustic signal sounds and the status changes to *Expired*.

- 7 Stop the highlighted timer with *[Stop]*.

The status of the timer changes to *Inactive*. The acoustic signal is switched off.

4.11 Memory

4.11.1 Overview

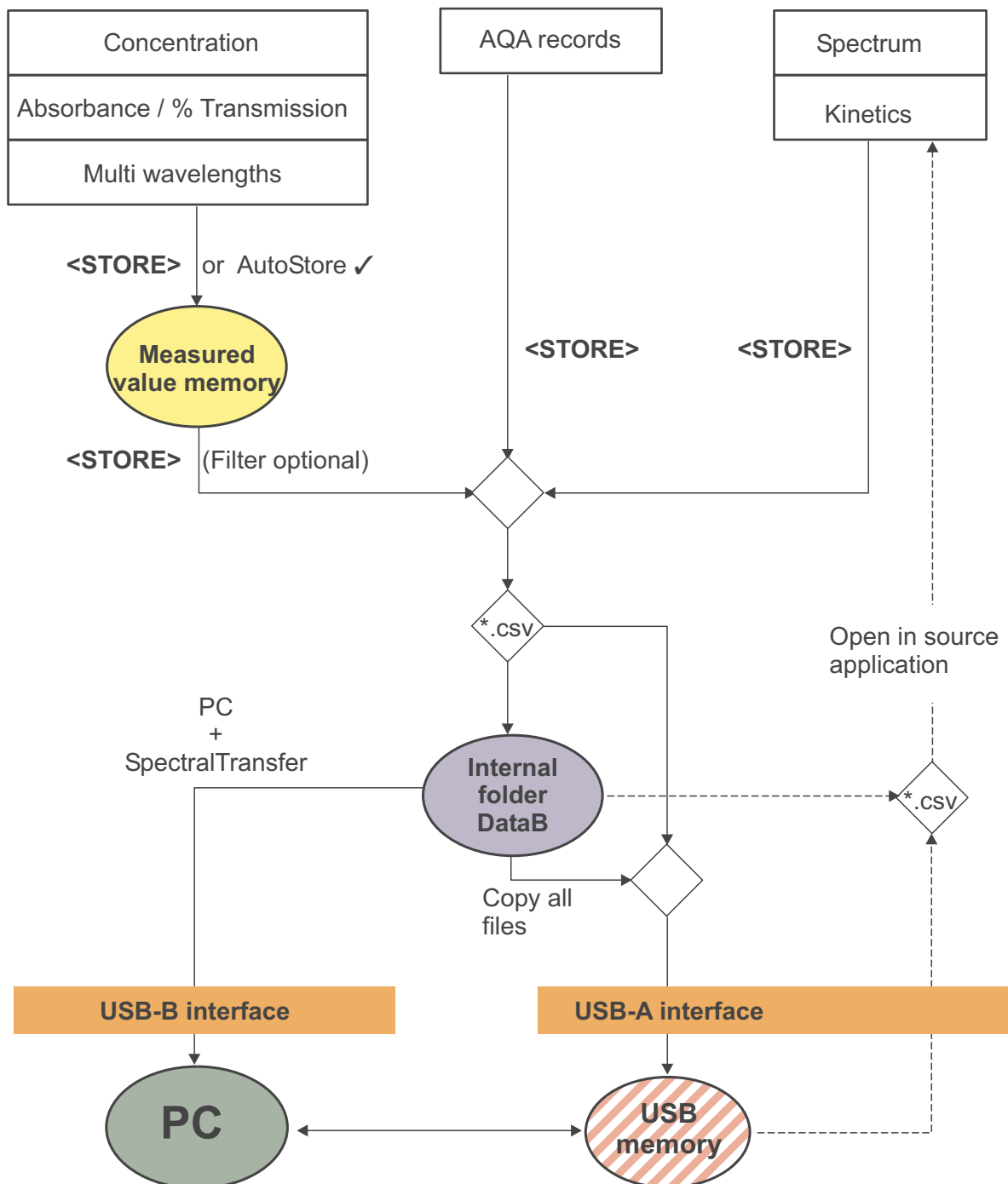

Measurement data	Save, back up, export
<i>Concentration,</i> <i>Absorbance / %</i> <i>Transmission</i> <i>Multi wavelengths</i>	<p>Measurement datasets of these measuring modes are first stored in the measured value memory of the photometer (1000 memory locations) with <STORE> or <i>AutoStore</i>.</p> <p>The measured value memory is available from the <i>Measurement data memory</i> menu. Here you can view, filter and export into a PC-readable file (*.csv) the stored measurement datasets (<STORE>).</p> <p>Csv files of these measuring modes cannot be reimported to the photometer.</p>
<i>Spectrum</i> <i>Kinetics</i>	<p>You can store and export measurement data of these measuring modes directly as a PC-readable file (*.csv) with <STORE>.</p> <p>Csv files of these measuring modes can be reimported and displayed on the photometer.</p>
AQA records	<p>You can store and export measurement data of these measuring modes directly as a PC-readable file (*.csv) with <STORE>.</p> <p>Csv files of records cannot be reimported to the photometer.</p>

For each export procedure you can select the location where the PC-readable files (*.csv) should be stored: either the photometer (*Internal DataB folder*) or an external memory (*USB memory*).

The files stored in the photometer (*Internal DataB folder*) can later be transferred to a connected PC or to an external memory (*USB memory*).

You can transfer to a USB memory device either individual files with measurement data or all files stored in the internal *Internal DataB folder*.

- Individual files (see section 4.12.1)
- All files (see section 4.12.2)

4.11.2 Instructions on using USB memory devices

The safety of data stored on USB memory devices depends on the quality of the memory device and the data transmission.

Data is stored partly or not at all if for example:

- The power supply of the external memory device is interrupted during the write process, or
- The external memory device is prematurely disconnected from the photometer during the data backup.

To prevent a data loss we recommend the following:

- Save all data internally in the photometer first.
- After performing a backup leave the USB memory device connected to the photometer for some time.
- Check whether the stored data is complete, e.g. on a PC.
- Use the USB memory device for data transport but not for permanent data storage.

4.11.3 Measurement datasets

Elements of a measurement dataset

A complete measurement dataset consists of:

- Consecutive number (is automatically assigned by the photometer)
- Date/time
- Identification (e.g. ID or "AutoStore")
- User name
- Measured parameter, e.g. method number, dilution, wavelength (depending on the measuring mode)
- Measured value with unit and, if necessary, citation form

Operations with measurement datasets

Measurement datasets can be

- stored (see section 4.11.4)
- displayed and printed (see section 4.11.6)
- filtered, i.e. selected or hidden based on certain criteria (see section 4.11.7 and section 4.11.8)
- deleted (see section 4.11.9).

If the storage is full

You can erase measurement datasets (see section 4.11.9), or overwrite the oldest dataset with the next storing procedure. A security prompt appears before a dataset is overwritten. To backup the measurement data, you can transmit the measurement datasets from the measurement data memory to the internal DataB folder or a USB memory device connected to the USB-A connection and archive them further from there (see section 4.12.3).

4.11.4 Saving measurement datasets manually

After each measurement, you can store the measurement data manually with the <STORE> key. It is stored in the measurement data memory. The memory symbol  in the header indicates that the measurement data displayed on the screen is ready to be stored. With the measuring modes, *Concentration*, *Absorbance / % Transmission*, and *Multi wavelengths* you have the additional option to automatically store all new measured values at the time of the measurement (*AutoStore*, see section 4.11.5).

Storing with identification (ID)

When storing manually, an input field for the identification (ID) appears after pressing the <STORE> key. Here you can enter an individual combination of alphanumeric characters for later easier identification of the measurement datasets. 30 digits are available for this.

4.11.5 Saving measurement datasets automatically

For the measuring modes, *Concentration*, *Absorbance / % Transmission*, and *Multi wavelengths* you can record every measured value automatically (*AutoStore*).

All automatically stored measurement datasets are given the ID "AutoStore". The "AutoStore" ID is overwritten if the same measured value is manually stored afterwards (<STORE>).

This ensures that every measurement dataset is stored in the data memory only once.

Activating AutoStore

Activate the *AutoStore* function as follows:

```
<HOME>
Concentration,
Absorbance / % Transmission, or
Multi wavelengths
├─ [Setup]
│  └─ Measurement data
│     memory
│  └─ Setup
```

The available functions are displayed.

- 1 Select and confirm *AutoStore*.
The *AutoStore* function is active (✓).



Note

The *AutoStore* setting is valid for all three measuring modes, *Concentration*, *Absorbance / % Transmission*, and *Multi wavelengths*.

4.11.6 Displaying measurement data memory

Depending on the operating situation, you can recall the measured value memory as follows:

From the main menu

```
<HOME>
[Setup],
├─ Measurement data memory
```

In Concentration mode

```
Concentration
├─ [Setup]
├─ Measurement data memory
```

In Absorbance / % Transmission mode

```
Absorbance / % Transmission
├─ [Setup]
├─ Measurement data memory
```

In Multi wavelengths mode

```
Multi wavelengths
├─ [Setup]
├─ Measurement data memory
```

Each of these options indicates the contents of the measurement data memory as a list as follows.

Measurement data memory			04/16/07 9:52
27.03.07 14:00 3.50 mg/l Ni	Administrator	AutoStore	
27.03.07 14:05 3.64 mg/l Ni	Administrator	AutoStore	
27.03.07 14:10 3.69 mg/l Ni	Administrator	AutoStore	
27.03.07 14:15 3.72 mg/l Ni	Administrator	AutoStore	
27.03.07 14:20 3.72 mg/l Ni	Administrator	AutoStore	
27.03.07 14:25 3.75 mg/l Ni	Administrator	AutoStore	
27.03.07 14:30 3.73 mg/l Ni	Administrator	AutoStore	
27.03.07 14:35 3.80 mg/l Ni	Administrator	AutoStore	
27.03.07 14:40 3.78 mg/l Ni	Administrator	AutoStore	
Filter ✓			
Memory allocation: 9/1000			
Setup	Single value	Delete	

If there are more datasets available than can be displayed, the arrows ▲ and ▼ are displayed additionally.

Filter ✓ indicates that filter settings are active. In this case, only those datasets are displayed that correspond to the selected filter criteria (see section 4.11.7).

Options Measurement datasets can be

- displayed in short form as a list or in details as individual values ([List] <—> [Single value])
- filtered (see section 4.11.7 and section 4.11.8)
- deleted (see section 4.11.9).
- with <STORE>, you can store the entire displayed list as a *.csv file in the internal DataB folder or on a USB memory device connected to the USB-A connection. The filter settings apply to the storing process. You can freely select the file name. Thus you can, e. g. store in a separate file and systematically archive measurement data of a certain period.
- with <PRINT>, the entire displayed list can be printed. The filter settings apply to the print process.

4.11.7 Filtering measurement datasets

The functions to display, delete and download stored measurement datasets refer to all stored measurement datasets that correspond to the specified filter criteria.

Filter criteria

The following filter criteria can be set:

- *Mode* (measured parameter)
- *User*
- *ID* (identification)
- *Date* (date from ... to ...)
- *Method* (for the measured parameters, *Concentration* and *Multi wavelength*)

<HOME>

*Concentration,
Absorbance / % Transmission, or
Multi wavelengths*

├ [Setup]
│ └ Measurement data
│ memory
└ Setup
 └ Filter

Filter

├ *Mode (Concentration, etc.)*
├ *User (<A...9>)*
├ *ID (<A...9>)*
├ *Date (from ... to ...)*
└ *Method*

The filter setting menu is displayed.

- 1 Set the filter criteria.
- 2 If necessary, deactivate any selected filter criteria with *[Reset entry]*.
- 3 Confirm the filter selection with *[Apply]*.

The *Measurement data memory* list is displayed.

The following information is displayed additionally:

- Current memory occupancy
- Active filter criteria (*Filter ✓*)

Measurement data memory	04/16/07 9:52
27.03.07 14:00 3.50 mg/l Ni Administrator AutoStore	
27.03.07 14:05 3.64 mg/l Ni Administrator AutoStore	
27.03.07 14:10 3.69 mg/l Ni Administrator AutoStore	
27.03.07 14:15 3.72 mg/l Ni Administrator AutoStore	
27.03.07 14:20 3.72 mg/l Ni Administrator AutoStore	
27.03.07 14:25 3.75 mg/l Ni Administrator AutoStore	
27.03.07 14:30 3.73 mg/l Ni Administrator AutoStore	
27.03.07 14:35 3.80 mg/l Ni Administrator AutoStore	
27.03.07 14:40 3.78 mg/l Ni Administrator AutoStore	
Filter ✓	
Memory allocation: 9/1000	
Setup	Single value Delete



Note

Alternatively, you can hide measurement datasets that meet the specified filter criteria with the *Selected values: invert selection* function (see section 4.11.8).

4.11.8 Inverting filters

With the *Selected values: invert selection* function you can hide all measurement datasets that correspond to the specified criteria of the filter (see section 4.11.7).



Note

You can use this function to select and delete measurement datasets no longer used.

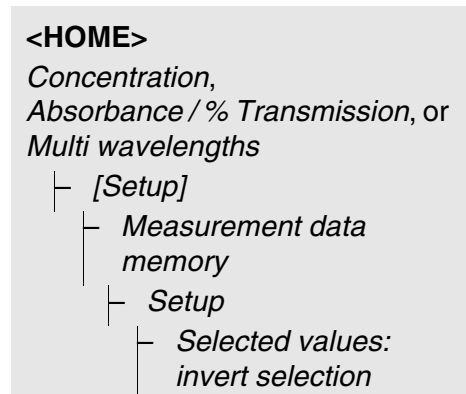

Measurement data memory			04/16/07 9:52	
27.03.07 14:00	3.50 mg/l Ni	Administrator	AutoStore	
27.03.07 14:05	3.64 mg/l Ni	Administrator	AutoStore	
27.03.07 14:10	3.69 mg/l Ni	Administrator	AutoStore	
27.03.07 14:15	3.72 mg/l Ni	Administrator	AutoStore	
27.03.07 14:20	3.72 mg/l Ni	Administrator	AutoStore	
27.03.07 14:25	3.75 mg/l Ni	Administrator	AutoStore	
27.03.07 14:30	3.73 mg/l Ni	Administrator	AutoStore	
27.03.07 14:35	3.80 mg/l Ni	Administrator	AutoStore	
27.03.07 14:40	3.78 mg/l Ni	Administrator	AutoStore	
Filter ✓				
Memory allocation: 9/1000				
Setup	Single value	Delete		

The *Measurement data memory* list is displayed. All measurement datasets corresponding to the filter criteria are hidden.

4.11.9 Erasing stored measurement datasets

If you no longer need any stored measurement datasets, you can erase them individually or altogether.

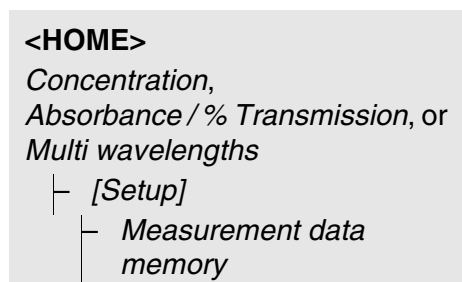

Measurement data memory			04/16/07 9:52	
27.03.07 14:00 3.50 mg/l Ni	Administrator	AutoStore		
27.03.07 14:05 3.64 mg/l Ni	Administrator	AutoStore		
27.03.07 14:10 3.69 mg/l Ni	Administrator	AutoStore		
27.03.07 14:15 3.72 mg/l Ni	Administrator	AutoStore		
27.03.07 14:20 3.72 mg/l Ni	Administrator	AutoStore		
27.03.07 14:25 3.75 mg/l Ni	Administrator	AutoStore		
27.03.07 14:30 3.73 mg/l Ni	Administrator	AutoStore		
27.03.07 14:35 3.80 mg/l Ni	Administrator	AutoStore		
27.03.07 14:40 3.78 mg/l Ni	Administrator	AutoStore		

Filter ✓
Memory allocation: 9/1000

Setup Single value Delete

The *Measurement data memory* list is displayed.

The filter settings used last are active.

Erasure functions

The following erasure functions are available.

- Erasing an individual measurement dataset
 - 1 Highlight a measurement dataset.
 - 2 Remove the highlighted measurement dataset with *[Delete]*.
- Erasing all measurement datasets of the displayed list
 - 1 Open the setting menu with *[Setup]*.
 - 2 Select and confirm *Delete memory (selected values only)*.
All measurement datasets corresponding to the current filter criteria are erased.

or
- Erasing all measurement datasets
 - Select and confirm *Delete memory (all values)*.
All measurement datasets are erased.

4.12 Copying files

If you want to back up measurement data files outside the photometer, there are several ways to copy them to external media.

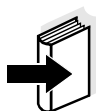

Note

Please follow the instructions on using USB memory devices (see section 4.11.2).

4.12.1 Copying individual files to a USB memory device

After the following measurements, the *Save* dialog opens and prompts you to save the data in a *.csv file:

- *Kinetics*
- *Spectrum*
- *AQA3/MatrixCheck*

If the data are not saved in *.csv format, they are lost when the measuring mode is terminated.



Note

During a kinetic recording, the current measurement is always saved in the file, "KineticsBackup.csv" for safety reasons.

The following measurement data are stored in the measured value memory automatically (see section 4.11.5) or manually (with the **<STORE>** key, see section 4.11.4):

- Concentration
- Multi wavelengths
- Absorbance / % Transmission

The data stored in the measured value memory can be filtered with filter criteria and then exported to the PC-readable *.csv format.

The photometer automatically offers a file name during the storage procedure.

**Example:
Saving data from the
measured value
memory**

```

<HOME>
Concentration,
Absorbance / % Transmission, or
Multi wavelengths
├─ [Setup]
│  └─ Measurement data
│     memory

```

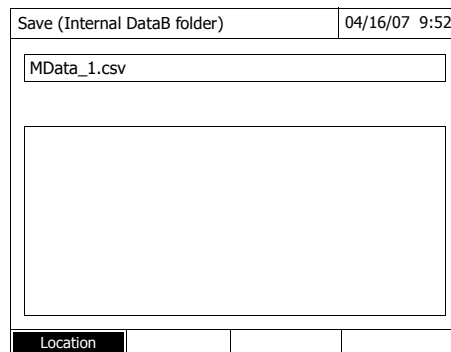

1 If necessary, set the filter criteria with *[Setup]*.

2 Open the save dialog with **<STORE>**.

The photometer automatically proposes the location *Internal DataB folder* and a file name.

3 If necessary, change the location with *[Location]* (*USB memory*).

4 If necessary, change the proposed file name.

5 Save the measurement data with **<STORE>**.

The data are stored.

If the photometer (*Internal DataB folder*) is selected as the location, the data can then be copied to a USB memory device (see section 4.12.2).

4.12.2 Copying all measurement data files to a USB memory device

Even if no PC is directly connected to the photometer, you can very simply transfer all measurement data files from the photometer (*Internal DataB folder*) to a connected USB memory device.

```
<HOME>
[Setup]
├ Save all data on USB
  memory
```

A message appears while the data are being saved.

When the data saving procedure is finished, a message appears.

- 1 Confirm the message with **<STORE>**.

All measurement data files from the photometer (*Internal DataB folder*) have been transferred to the USB memory device.

The complete folder structure from the photometer is created on the USB memory device. The individual measurement data files are stored in subfolders sorted by measurement data types.

4.12.3 Copying files to a PC

After saving measurement data in csv format you can copy them to a PC.

Measurement data in csv format can be directly imported to and processed in spreadsheets such as Microsoft® Excel®.



Note

Depending on the country variant, some spreadsheet programs require a certain decimal separator for the correct import of numerical values (comma or point). The decimal separator can be selected in the following menu:

<HOME> -> *General setup* -> *Data transfer/Printer* -> *Decimal separator for csv-Files*.

Files containing measurement data can be copied to a PC in the following ways:

- Safely and conveniently by means of a USB memory device as a temporary storage (see section 4.12.1 and section 4.12.2). Subsequently, you can connect the USB memory device to a PC and read out the data.
- Safely and conveniently by means of the "SpectralTransfer" program (see operating manual of the "SpectralTransfer" program). The "SpectralTransfer" program and the corresponding operating manual is provided on the enclosed CD-ROM.

4.13 Transmitting data

4.13.1 Printer and terminal programs

Usable printers

Data can be printed with the following printers:

- Matrix printer connected to the RS232 interface
- Standard printer (ink or laser) connected to the USB-A interface



Note

Suitable are all printers that can interpret the PCL-3 printer control language.

The printer symbol  indicates that the display contents can be printed. To print, press <PRINT>.

PC + terminal program

The data can also be received by a PC with terminal program instead of a printer. For this the PC is connected to the photometer via the RS232 interface. The output is identical.



Note

In the following sections, "print" means both output to a printer and output to a PC + terminal program.

4.13.2 Settings for data transmission

Settings are possible for the data transmission to a printer or PC.

Decimal separators for CSV files

For the output of CSV files you can select either a comma or a point as the decimal separator. The setting is made in the following menu:

<HOME> -> *General setup* -> *Data transfer/Printer* -> *Decimal separator for csv-Files* -> *Comma (12,34)* or *Point (12.34)*.

Short and long version

When printing measurement datasets, you can select a short or long version with different information contents. The setting is made in the following menu:

<HOME> -> *General setup* -> *Data transfer/Printer* -> *Data format (print)* -> *Short* or *Extended*.

Baud rate for RS232 interface

The baud rate can be set for printers that are operated at the RS232 interface. Adjust the photoLab® 6600 UV-VIS to the baud rate of the printer. The setting is made in the following menu:

<HOME> -> *General setup* -> *Data transfer/Printer* -> *Baudrate for printer* -> 1200 ... 19200.

4.13.3 Printing measurement datasets

This section describes how to print measurement datasets of the measuring modes, *Concentration*, *Absorbance / % Transmission*, and *Multi wavelengths*.

By means of sample printouts, the printed information is described below:

Concentration and Multi wavelengths mode

```
21 05.06.07 14:05:41 C4/25 844 mg/l COD      Inlet
Administrator 0.005 02.06.07 11:02:13 2 AQA1: 9 AQA2: 14
```

Structure of the lines from left to right:

1st line:

*[Consecutive no.] [Date] [Time] [Method name] [Measured value] [Unit]
[Citation form] [Dilution] [ID or "AutoStore"]*

2nd line (long version only):

*[User] [Reagent blank value] [Date of blank value measurement]
[Time of blank value measurement] [Lot ID of blank value measurement]
[AQA1: label] [AQA1: record no.] [AQA2: label] [AQA2: record no.]*



Note

Optional elements (e.g. dilution or ID) are output only if they were really used for measurement or storage.

Absorbance / % Transmission mode

```
14 05.06.07 11:25:01 445 nm 0.609 Absorbance AutoStore
Administrator 0.133 02.06.07 09:59:01 AQA1: 9
```

Structure of the lines from left to right:

1st line:

*[Consecutive no.] [Date] [Time] [Wavelength] [Measured value]
["Absorbance" or "Transmission" mode] [ID or "AutoStore"]*

2nd line (long version only):

*[User] [Value of reference absorbance] [Date of reference absorbance] [Time
of reference absorbance] [AQA1: label] [AQA1: record no.]*



Note

Optional elements (e.g. ID or reference absorbance) are output only if they were really used for measurement or storage.

4.13.4 Printing Kinetics records

Sample printout

```
SpectroFlex 6600 09130512 1.30-WTW-1.60 Administrator
05.06.07 12:14:55
320 nm

Time [s] Absorbance
6         0,092
17        0,077
25        0,073
35        0,077
45        0,071
..        .....
..        .....
(etc.)
```

Structure of the lines from left to right

1st line:

[Instrument type] [Series number] [Version of meter software and method data] [User]

2nd line:

[Start date] [Start time]

3rd line:

[Wavelength]

6th and following lines:

Passed time with related measured value

4.13.5 Printing spectra

Sample printout

```
SpectroFlex 6600 09130512 1.30-WTW-1.60 Administrator
07.06.07 09:47:00

Wavelength [nm] Absorbance
320              0,238
321              0,240
322              0,241
323              0,240
324              0,239
...             .....
...             .....
(etc.)
```

Structure of the lines from left to right

1st line:

[Instrument type] [Series number] [Version of meter software and method data] [User]

2nd line:

[Start date] [Start time] [Wavelength]

5th and following lines:

Wavelength with related measured value

4.14 Analytical quality assurance (AQA)

4.14.1 General information

The target of the analytical quality assurance (AQA) is to secure correct and precise measurement results.



Note

Settings for AQA checks are only available for users of the user group, administrator.

Every registered user can carry out the AQA check (see also section 4.15.1).

Analytical quality assurance (AQA) can be carried out in two steps independent of each other:

- AQA1: Monitoring of the photometer
- AQA2: Monitoring of the total system.
It comprises the photometer, the used test, the accessories and the user's way of working.

The monitoring includes a check procedure that has to be successfully repeated by the user within a certain period (AQA interval).



Note

The AQA monitoring is not active in the delivery condition.

AQA in measured value documentation

All values that are measured after a passed check and within the AQA interval are given the addition *Protocol ID* in the measured value documentation. This addition is used to identify the relevant AQA inspection record.

4.14.2 Photometer monitoring (AQA1)

At least one set of test standards such as Spectroquant® PhotoCheck or CertiPUR® is required for the photometer monitoring.

The administrator specifies which test standard has to be used as the minimum requirement for the AQA1 monitoring.

The extent of the monitoring can be enlarged with further test standards.



Note

Settings for AQA checks are only available for users of the user group, administrator.

Every registered user can carry out the AQA check (see also section 4.15.1).

Spectroquant® PhotoCheck

The PhotoCheck consists of 12 test standards in duplicate, 2 zero cells and 2 cells to check the barcode reader. Each PhotoCheck package contains a lot dependent test certificate with all nominal values (absorbances) and tolerances of the test standards. These values are entered in the photometer during the configuration of the AQA1 check.

CertiPUR® test standards

Each CertiPUR® standard is provided with a lot dependent test certificate with all nominal values (absorbances) and tolerances of the test standards. The values were preset in the factory.



Note

Observe the shelf life of the test standards. The values in the photometer always have to be checked when a new package of test standard is used. If necessary, adjust the values at the photometer.

Overview of the photometer monitoring

Photometer monitoring (AQA1) consists of the following parts:

- Configuring settings in the *AQA1 setup* menu.
 - Activate AQA1
 - Specify AQA1 Interval
 - Activate/deactivate the meter lock for missing or expired AQA1 check
 - Define the extent of the AQA1 monitoring by activating or deactivating the individual test standards.
 - Enter the nominal values, tolerances and lot numbers for the individual test standards
- Carrying out the AQA1 check. The photometer compares the results with the nominal values while taking into account the tolerances.

The steps are described in detail below.

Activating AQA1 The AQA1 monitoring is activated in the *Mode* menu:

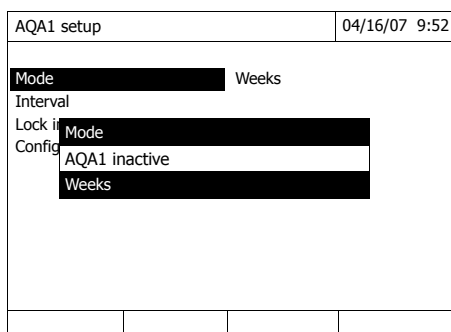
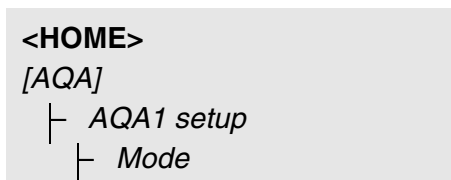

Select and confirm *Weeks*.
 AQA1 is active.
 The *Interval* setting indicates *Weeks* as the interval unit.

Defining the AQA1 Interval

The AQA1 Interval defines the interval between two AQA1 checks. When an interval has expired, the following consequences become effective:

- Warning and loss of the AQA1 labeling
- Locking of the photometer against all measurements (if activated).

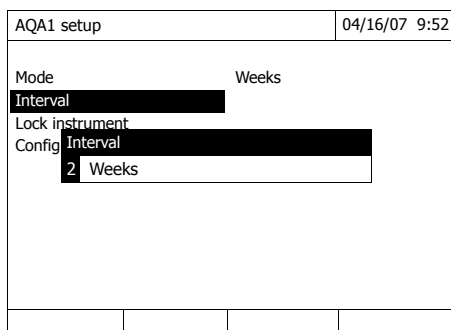
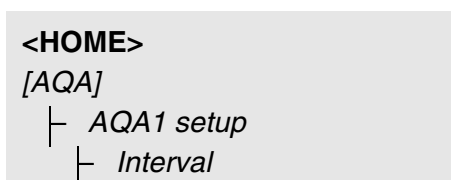

- 1 Enter a numeric value (2 to 52 weeks) (<0...9>) and confirm
 The *Interval* defined for the AQA1 check is active.

Configuring the lock of the photometer

Here you configure whether or not the photometer will be locked against all measurements if there is no valid AQA1 check or the interval for the AQA1 check has expired.

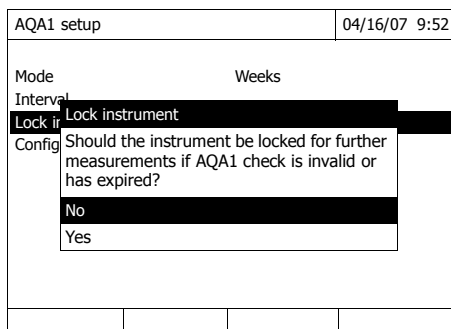
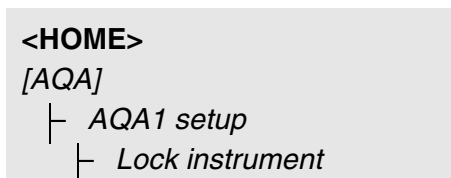

1 Select and confirm **Yes**.

The photometer is locked against all measurements if the AQA1 check is invalid or the AQA1 interval has expired.

Configuration of tests ...

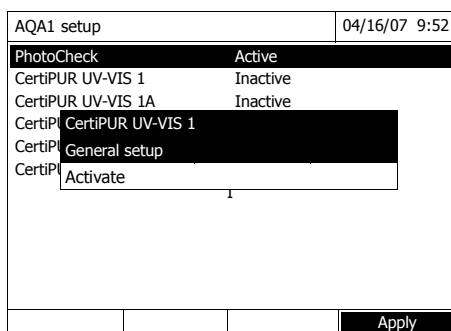
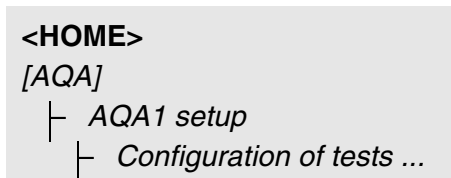

All possible test standards or test standard sets are listed.

- 1 Select and confirm a test standard or test standard set.
- 2 Adjust and confirm the extent of the monitoring with *Activate* or *Deactivate*.
- 3 Confirm the test standard (set) once again.
- 4 Switch to the adjustment of the nominal values and tolerances with *Setup*.

PhotoCheck		04/16/07 9:52	
Lot number:		HC616115	
Use by		16.04.2008	
	Target value	Tolerance	
445/1	0.196	± 0.020	
445/2	0.500	± 0.030	
445/3	0.998	± 0.040	
445/4	1.508	± 0.050	
525/1	0.197	± 0.020	
525/2	0.495	± 0.030	
525/3	0.992	± 0.040	
525/4	1.496	± 0.050	
			Apply

Example, PhotoCheck:

- 5 Using <▲><▼> and <◀><▶>, select the *Lot number*, *Target value* or *Tolerance* entries and open them for editing with <START·ENTER>.
- 6 Enter and confirm the required value (<0...9>)
- 7 Accept all values with [Apply].

Carrying out the AQA1 check (example: PhotoCheck)

The AQA1 check comprises the check with all test standards activated in the menu, *AQA menu / AQA1 setup / Configuration of tests ...* for AQA1 (see page 123).

First, a zero adjustment for all wavelengths takes place. Subsequently, the first individual checks with the selected test standards take place (e.g. *PhotoCheck*).

```
<HOME>
[AQA]
└ AQA1 check
```

PhotoCheck		04/16/07 9:52	
Reference measurement			
Please insert zero cell (distilled water).			

The photometer is ready for the zero adjustment.

- 1 Insert the zero cell. The cell is automatically recognized and the zero adjustment is started for all wavelengths.

After the successful zero adjustment, the photometer is ready to measure the PhotoCheck test standard 445/1.

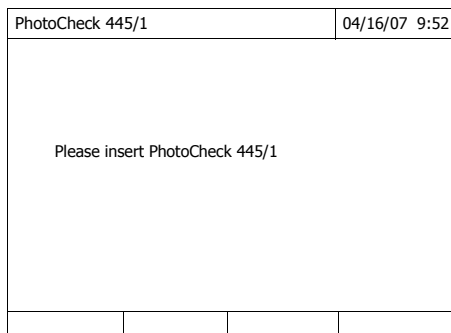

2 Insert the cell.
The cuvette is automatically recognized and the measurement started.

After measuring, the measurement result, Target value, Tolerance and an evaluation (OK or failed) are displayed.

The photometer offers to repeat the measurement if the check failed.

If the check was successful, the measurement of the next PhotoCheck test standard, e.g. 445/2, appears on the display.

3 Measure all test standards in the same way.
After all test standards are successfully measured, the check is passed.

Test record A test record is displayed after the check. It can be printed and stored as a file (in the internal DataB folder or USB memory device at the USB-A connection, see section 4.11.1).

Sample printout:

```

SpectroFlex 6600  09130512 1.30-WTW-1.60 Administrator
AQA1              OK
Protocol ID      9
Executed by:    Administrator
Executed        22.05.2007
Valid until:    26.06.2007

PhotoCheck      OC479094                OK
445-1           0.200 +- 100             0.192
445-2           0.500 +- 200             0.511
445-3           1.000 +- 200             1.006
445-4           1.500 +- 200             1.526
525-1           0.200 +- 200             0.247
.....
.....
(etc.)
    
```



Note
Afterwards you can view the last AQA1 test record under *AQA1 info*.

4.14.3 Total system monitoring (AQA2)

For the total system monitoring, standard solutions with a defined analyte content are required (preferably certified Spectroquant® CombiCheck standards).

**Note**

Settings for AQA checks are only available for users of the user group, administrator.

The AQA check can be carried out by any registered user.

**Spectroquant®
CombiCheck**

Spectroquant® CombiCheck standards are multiparameter standards ready to use, i. e. they can be used for several test sets (methods).

In addition to the CombiCheck standards, one parameter standard solutions can also be used. They are prepared by dilution to the respective end concentration. The end concentration should be in the middle of the measuring range.

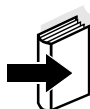
**Overview of the total
system monitoring****Note**

The suitable CombiCheck standards and one parameter standards are listed in the WTW catalog or on the Internet.

Total system monitoring (AQA2) consists of the following parts:

- Configuring the general settings in the *AQA2 setup* menu.
 - Activate AQA2
 - Select the AQA2 interval unit (Weeks or Measurements)
 - Activate/deactivate the measurement lock for missing or expired AQA2 check. The measurement lock is effective for all methods that were activated for AQA2 monitoring
- Selecting the method to be activated for AQA2
- Configuring the method-specific settings in the *AQA2 setup* menu.
 - Activate AQA2
 - Specify AQA2 Interval
 - Enter the nominal value, tolerance and designation (standard ID) for the test standard
- Carrying out the AQA2 check. During the check the test is carried out with the standard solution as the sample while the other conditions are the same. The photometer compares the result with the nominal value while taking the tolerance into account.

The steps are described in detail below.

General AQA2 settings

```
<HOME>
[AQA]
├─ AQA2 setup
```

AQA2 setup	04/16/07 9:52
Mode	Weeks
Lock methods	Yes
Method...	
Method list	

- 1 Select and confirm *Mode*.
The *Mode* selection field pops up.
- 2 Select and confirm *Weeks* or *Measurements*.

AQA2 is active. For all methods, the AQA2 intervals are entered either in weeks or number of measurements.
- 3 Accept the general settings with *[Apply]*.



Note

When the mode (*Weeks* or *Measurements*) is changed, all AQA2 intervals are reset to the preset values.

Locking the method

Here you configure whether or not a method will be locked against measurement if there is no valid AQA2 check or the interval for the AQA2 check has expired.

```
<HOME>
[AQA]
├─ AQA2 setup
```

AQA2 setup	04/16/07 9:52
Mode	Weeks
Lock methods	Yes
Method...	
Method list	

- 1 Select and confirm *Lock methods*.
- 2 Select and confirm *Yes*.

The method lock is enabled.

Each method will be locked if the AQA2 check is invalid or the AQA2 interval has expired.

Activating AQA2 monitoring for a method

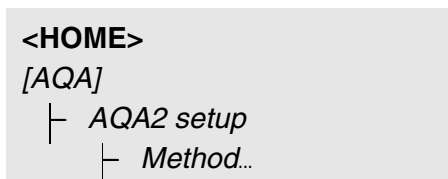

AQA2 setup	04/16/07 9:52
Method	3: A6/25
AQA2	AQA2 active
Interval	12 Weeks
Target value	4.00 mg/l NH ₄ -N
Tolerance	0.50 mg/l NH ₄ -N
Standard ID	
Method list	

- 1 Select a method (see section 4.5.3).
- 2 Select and confirm *AQA2*.
- 3 Select and confirm *AQA2 active*.
AQA2 is active for this method.

Defining the AQA2 Interval, nominal value and tolerance

The AQA2 Interval defines the interval between two AQA2 checks. When an interval has expired, the following consequences become effective:

- Warning and loss of the AQA2 labeling
- Locking of the method against measurement (if activated).

Setting range:

1 to 12 weeks (default: 12 weeks) or

1 to 10000 measurements (default: 200 measurements)



Note

The unit of the AQA2 interval (Weeks or Measurements) is defined in the line, *Mode* (see page 127).

AQA2 setup	04/16/07 9:52
Method	3: A6/25
AQA2	AQA2 active
Interval	12 Weeks
Target value	4.00 mg/l NH ₄ -N
Tolerance	0.50 mg/l NH ₄ -N
Standard ID	
Method list	

- 4 Select the *Interval* and enter the AQA2 interval.
- 5 If necessary, adjust the values for *Target value* and *Tolerance*.
- 6 Optional: Select *Standard ID* and enter a designation. The designation is recorded in the AQA2 documentation.

Repeat the steps 1 to 8 if you want to configure further tests for AQA2.

Carrying out the AQA2 check for a method

```
<HOME>
[AQA]
├─ AQA2 check
```

AQA2 check	04/16/07 9:52
Target value 2.00	
To start measurement, insert cell or press <Start/Enter>	
3: A6/25 16 mm	NH ₄ -N 0.20 - 8.00 mg/l

- 1 Carry out the check like a normal measurement (see section 4.5.1 to 4.5.3).
- 2 Insert the cell or start measurement with **<START·ENTER>**.

After the measurement is completed, the result and its evaluation are displayed.

If the check failed, it is possible to repeat the measurement.

If the check was successful, the *AQA2 check* function is finished.

Test record

A test record is displayed after the check. It can be printed and stored as a file (in the internal DataB folder or USB memory device at the USB-A connection, see section 4.11.1).

Sample printout:

```
SpectroFlex 6600 09130512 1.30-WTW-1.60 Administrator
AQA2 OK
Protocol ID 32
Executed by: Administrator
Executed 21.05.2007
Valid until: 13.08.2007

Method 6: P6/25 PO4-P
Standard ID CC10 OC557775
Target value 0.80 +- 0.08 mg/l
Measured value 0.84 mg/l
```



Note

Later you can view the last AQA2 test records for all methods monitored with AQA2 under *AQA2 info*.

4.14.4 AQA3/MatrixCheck

The *MatrixCheck* is used to check if the photometric determination is disturbed by other substances present in the sample (sample matrix). The MatrixCheck can be carried out by spiking or diluting:

The photometer enables a simplified MatrixCheck with the aid of the Spectroquant® CombiCheck R-2 addition solution. The MatrixCheck can be carried out immediately. The volumes required for the sample and standards are displayed on the screen. The MatrixCheck is then carried out with a single spiking.

For the MatrixCheck with a standard or your own, however, you can enter the number of spikings or dilutions yourself (max. 3).



Note

Settings for AQA checks are only available for users of the user group, administrator.

The AQA check can be carried out by any user.

MatrixCheck by spiking

For the MatrixCheck by spiking, the photometric determination is repeated after a defined amount of analyte has been added to the test sample in the form of standard solutions.

The nominal value for the determination is calculated from the added amount of analyte, provided that there is no disturbance due to the sample matrix. After the photometric determination the measured value is compared to the nominal value and the recovery rate is calculated. A matrix disturbance is likely if the recovery rate is less than 90 % or more than 110 %.

MatrixCheck by diluting

For the MatrixCheck by dilution, the photometric determination is repeated after the test sample has been diluted with distilled water.

The nominal value for the determination is calculated from the dilution, provided that there is no disturbance due to the sample matrix. After the photometric determination the measured value is compared to the nominal value and the recovery rate is calculated. A matrix disturbance is likely if the recovery rate is less than 90 % or more than 110 %.

Practical instructions

- After evaluating the measured value of the sample the photometer suggests for the MatrixCheck to spike or dilute the sample and standard with suitable volumes.
You can change the suggested values of the volumes for the sample and standard. The photometer checks your entries and informs you of errors (e.g. if a nominal value is outside the measuring range of the test). For each spiking or dilution, the relevant nominal concentration value is displayed.
- To be able to reliably recognize matrix effects by spiking, the volume increase after spiking should be small.
- To be able to reliably recognize matrix effects by diluting, the dilution factor should be high.
- You can carry out the MatrixCheck as a series of measurements, consisting of up to three determinations with different spiking volumes or dilutions respectively.
- Prepare all test sample solutions simultaneously at the beginning of the series of measurements.

Overview of the AQA3/MatrixCheck

The MatrixCheck consists of the following parts:

- Configuring settings in the *AQA3/MatrixCheck setup* menu.
 - Specify the maximum deviation from the nominal value after spiking or diluting (default setting: 10%)
- Carrying out the AQA3 / MatrixCheck

Specifying the maximum deviation from the nominal value

The assessment of the recovery rate is determined with the maximum deviation from the nominal value. The assessment of the recovery rate is displayed next to the recovery rate after the check has been carried out.

```
<HOME>
Concentration
├─ [Setup]
│  └─ AQA
│     └─ AQA3/MatrixCheck
│        └─ setup
│           └─ Maximum difference
```

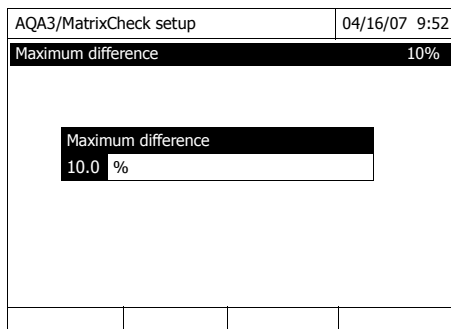

- 1 Enter and confirm a numerical value.
The setting is active.
- 2 Exit the menu with <ESC>.

Carrying out the MatrixCheck

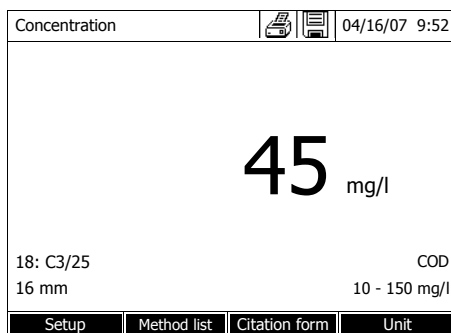

- 1 Measure the original sample without spiking or diluting it (see section 4.5.1 to 4.5.3).
- 2 The measured value is displayed.
- 3 Open the setting menu with [Setup].
- 4 Select and confirm AQA.
- 5 If necessary, check the settings in the menu, AQA3/MatrixCheck setup.
- 6 Select and confirm AQA3/MatrixCheck.

The display for the MatrixCheck opens up.

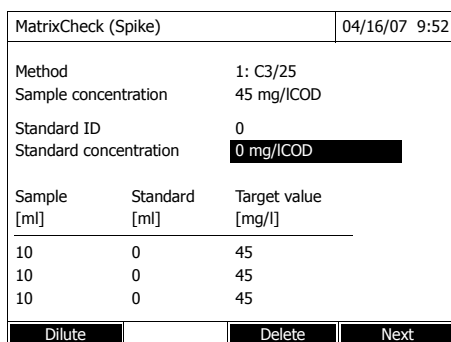

If the spiking with the standard values of the CombiCheck R-2 suggested by the photometer would cause the measuring range to be exceeded, the MatrixCheck by diluting is automatically suggested.



Note

The following description shows the proceeding for the MatrixCheck by spiking. To switch to the MatrixCheck by dilution, use the [Dilute] function key. The proceeding is similar there, but the entry of the Standard ID and Standard concentration is not applicable.

MatrixCheck (Spike)		04/16/07 9:52	
Method	1: C3/25		
Sample concentration	45 mg/ICOD		
Standard ID	COD 1500		
Standard concentration	400 mg/ICOD		
Sample [ml]	Standard [ml]	Target value [mg/l]	
10	0.5	62	
10	1	77	
10	1.5	91	
Dilute		Delete	Next

7 In the *Standard ID* entry field, select the simplified MatrixCheck with the CombiCheck standard solution or enter a designation for another standard solution used.

If the CombiCheck is selected, no more entries are required (continue with step 10).

8 Enter the concentration of the used standard solution in the *Standard concentration* entry field.

Specifying the series of measurements:

9 Enter the volumes of sample and standard of the individual test sample solutions in the columns, *Sample [ml]* and *Standard [ml]*. The nominal value is calculated after each entry.

- You can delete a measurement from the series of measurements with [*Delete*].

Note that all nominal values have to be within the measuring range of the test.

10 Using [*Next*], accept all entries on the page and switch to the next page. The entries are checked by the photometer.

The photometer is ready to carry out the series of measurements.

MatrixCheck (Spike)		04/16/07 9:52	
Method	1: C3/25		
Sample concentration	45 mg/ICOD		
Sample [ml]	Standard [ml]	Target value [mg/l]	nominal [mg/l]
10	0.5	62	58
10	1	77	
10	1.5	91	
Back		Measureme	Complete

Carrying out the series of measurements:

According to the program, the samples are measured top down. You can, however, select the samples yourself and thus change the order with <▲><▼>.

11 Use [*Measurement*] to proceed to the measurement of the (first) sample.

MatrixCheck		04/16/07 9:52	
Method	1: C3/25		
Sample concentration	45 mg/ICOD		
Sample	10 ml		
Standard	0.5 ml		
To start measurement, insert cell or press <Start/Enter>			
16 mm			
Back			

The measurement display appears.

12 Insert the cell with the respective sample.

The sample is measured.

MatrixCheck		04/16/07 9:52	
Method	1: C3/25		
Sample concentration	45 mg/ICOD		
Sample [ml]	Standard [ml]	Target value [mg/l]	nominal [mg/l]
10	0.5	62	58 94 % ✓
10	1	77	
10	1.5	91	
Back		Measurement	Complete

After the measurement, the recovery rate is displayed in the right table column.

The assessment of the recovery rate is displayed next to the recovery rate (✓ or X).

The criteria for the assessment are determined in the menu, *AQA3/MatrixCheck setup / Maximum difference*.

13 If necessary, repeat the steps 11 and 12 for the remaining samples.

14 Use *[Complete]* to complete the MatrixCheck.

The *Save* dialog box pops up.

15 If necessary, change the storage location with *[Location]: Internal DataB folder*.

Exchange folder in the instrument or

USB memory:

USB memory device connected at the USB-A connection.

16 If necessary, change the file name.

17 Save the file with **<START·ENTER>**.

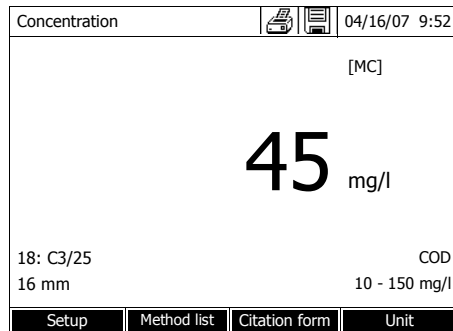

The display returns to the measured value display of the original sample without spiking / dilution.

The [MC] status indicator is displayed. A MatrixCheck was carried out for this measured value.

Test record

The result of the MatrixCheck is displayed in a test record. You can print this record and save it as a file.

To save the file in the photometer, select the *Internal DataB* folder as the location. To save the file in an external USB memory device at the USB-A connection, select *USB memory* as the location (see section 4.11.1).

Sample printout:

```

SpectroFlex 6600  09130512 1.30-WTW-1.60 Administrator
MatrixCheck      OK
Protocol ID      7
Method           1: C3/25 COD
Sample concentration  45 mg/lCOD
Standard ID      COD 1500
Standard concentration400 mg/lCOD

Sample   Standard   Target value   Actual value
ml       ml             mg/l           mg/l
10       0.5            62             58           94% OK
10       1              77             71           92% OK
10       1.5            91             77           85% OK
    
```

4.15 User management

The functions of the user management are only available for users of the user group, *Administrator*.

An administrator can

- activate or deactivate the user management for the meter
- create, change or delete individual user accounts.

4.15.1 User levels and user rights

The photoLab® 6600 UV-VIS allows the management of up to 100 users. Every user is member of a user group with defined user rights.

User groups

There are three hierarchical user groups:

- *Administrator* (top level)
- *User* (user account registered by the administrator)
- *Guest* (user without user account)

Administrators and users log in to the photometer with their user name and password. Guests can optionally enter a name for their login. Thus, documented measured values can later be assigned to the user.

User rights in detail

Action	Adminis- trator	User	Guest
Select methods	✓	✓	✓
Carry out measurements	✓	✓	✓
Store measurement data	✓	✓	✓
Check photometer (AQA1)	✓	✓	⊘
Check total system (AQA2)	✓	✓	⊘
AQA1 measured value labeling	✓	✓	✓
AQA2 measured value labeling	✓	✓	⊘
Edit user-defined methods	✓	✓	⊘
Change AQA settings	✓	⊘	⊘
Clear the memory	✓	⊘	⊘
Set the date and time	✓	⊘	⊘
Administrate users	✓	⊘	⊘
Reset photometer settings	✓	⊘	⊘
Carry out software update	✓	⊘	⊘



Note

You can also switch off the user management and reactivate it as necessary. To do so, you need administrator rights. If the user management is switched off, the user name and password do not have to be entered. Each user has full rights.

4.15.2 Activating or deactivating the User management function

Each user can activate the user management function. If the function is deactivated, each user has administrator rights.

Only members of the user group, administrator can deactivate the user management function.

If the function is active, each user has to log in to the photometer. After the login, the user has certain rights depending on the user group.

Activating the user management function

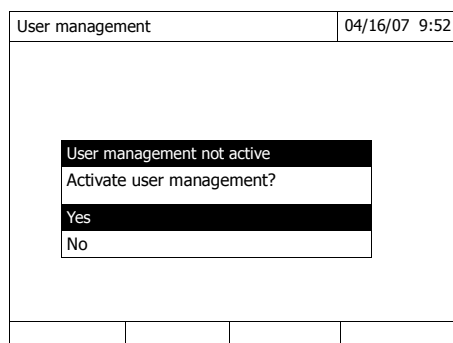
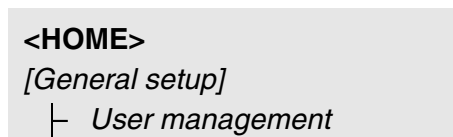

- 1 Select and confirm Yes.
The user management function is active.
When the user management function is activated, a user account for the administrator is created. The user name is "Administrator".
The preset password for this user account is "admin".
Change this password as soon as possible.

Deactivating the user management function

```
<HOME>
[General setup]
├─ User management
│   └─ [Setup]
│       └─ Deactivate user
│           management
```

The user management function is inactive.

Each user has administrator rights.



Note

If the user management is deactivated by a user of the *Administrator* user group, all user accounts that were set up are lost. The password for the administrator is reset to "admin".

4.15.3 Creating, changing or deleting a user account

When the user management function is active, a user with administrator rights can administrate user accounts.

Creating a user account

During the creation of a user account, the *Name*, whether or not the user belongs to a *User group* and the *Password* are defined.

```
<HOME>
[General setup]
├─ User management
│   └─ [Add]
```

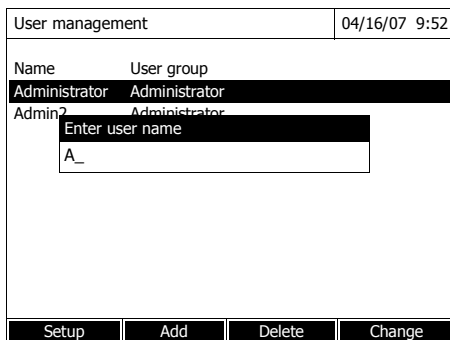

The input field for the new user name pops up.

- 1 Enter the user name (<A...9>) and confirm.

The selection field for the user group (*Administrator / User*) pops up.

- 2 Select and confirm the user group.

The input field for the password pops up.

- 3 Enter the password (<A...9>) and confirm.

The user account is created and appears in the list of user accounts.

Editing a user account

When a user account is changed, the *User group* and *Password* can be changed.

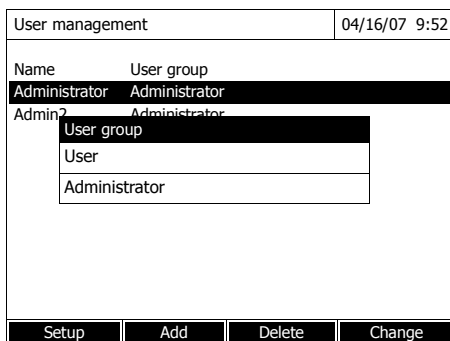
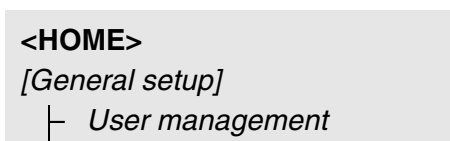

- 1 Select a user account.
- 2 Press [*Change*] to edit the user account.

The selection field for the user group (*Administrator / User*) pops up.

- 3 If necessary, select and confirm another user group.

The input field for the password pops up.

- 4 If necessary, enter (<A...9>) and confirm another password.

The user account is changed and appears in the list of user accounts.

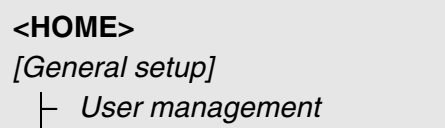
**Deleting a user
account**

<HOME>
[General setup]
└ User management

- 1 Select a user account.
- 2 Delete the user account with *[Delete]*.
A security prompt appears:
Confirm deletion ?
- 3 Confirm the security prompt.
The user account is deleted.

4.15.4 Login with active user management

To be able to always assign measurement data to a user, the administrator can activate the user management function. After doing so, the photometer can only be operated after login with a user name. Depending on the authorization class (administrator, user, guest), important settings are released for changes or locked.

**Note**

The user management function is not active in the delivery condition of the photoLab® 6600 UV-VIS. Every user can carry out all functions.

When the user management function is activated, a user account for the administrator is created. The user name is "Administrator".

The preset password for this user account is "admin".

Change this password as soon as possible.

Make sure to use the correct spelling (upper and lower case) of user name and password for the login.

After logging in to the *Administrator* group with a user name, you can create further users or administrators or switch off the user management function.

The *Login* window with the *Enter user name* prompt appears after the meter has been switched on and after a user has logged off.

In the following example, a user will log in with the user name, "Administrator".

The photometer is switched on.
The *Login* dialog is displayed.

Login	04/16/07 9:52
<div style="border: 1px solid black; padding: 5px; margin: 10px auto; width: 150px;"> <p>Enter user name</p> <p>Administrator</p> </div>	
<div style="border: 1px solid black; width: 150px; height: 20px; margin: 10px auto;"></div>	
<div style="border: 1px solid black; width: 150px; height: 20px; margin: 10px auto;"></div>	
<div style="border: 1px solid black; width: 150px; height: 20px; margin: 10px auto;"></div>	

- 1 Enter the user name (<A...9>) and confirm.

The input field for the password pops up.

If the user name is not known (or incorrectly spelled) it is possible to log in without a password as a guest with restricted rights (see section 4.15.1).

Login	04/16/07 9:52
<div style="border: 1px solid black; padding: 5px; margin: 10px auto; width: 150px;"> <p>Enter password</p> <p>admin</p> </div>	
<div style="border: 1px solid black; width: 150px; height: 20px; margin: 10px auto;"></div>	
<div style="border: 1px solid black; width: 150px; height: 20px; margin: 10px auto;"></div>	

- 2 Enter the password (<A...9>) and confirm.

If the password is written correctly (note upper and lower case), the *Home* main menu opens up. The entered user name is displayed.

Home (Administrator)	04/16/07 13:57
<div style="border: 1px solid black; padding: 5px; margin: 10px auto; width: 150px; background-color: #333; color: white;"> <p>Concentration</p> </div>	
<div style="border: 1px solid black; padding: 5px; margin: 5px auto; width: 150px;"> <p>Absorbance / % Transmission</p> </div>	
<div style="border: 1px solid black; padding: 5px; margin: 5px auto; width: 150px;"> <p>Multi wavelengths</p> </div>	
<div style="border: 1px solid black; padding: 5px; margin: 5px auto; width: 150px;"> <p>Spectrum</p> </div>	
<div style="border: 1px solid black; padding: 5px; margin: 5px auto; width: 150px;"> <p>Kinetics</p> </div>	
<div style="display: flex; justify-content: space-around; margin-top: 10px;"> General setup Logout AQA Info </div>	

4.15.5 Changing the password

The administrator sets up user accounts and assigns a password to each user account.

As soon as any user has successfully logged in with the password, they can change the password for their user accounts themselves.

```
<HOME>
[General setup]
├─ User management
│  └─ Change password
```

User management	04/16/07 9:52
<input type="text" value="Old password"/>	

- 1 Enter and confirm the old password.
- 2 Enter and confirm the new password.

The password is changed.

4.16 Reset

You can reset (initialize) the measurement settings or all settings.



Note

The *Reset* function is available for users of the user group, Administrator only.

You have the following options of resetting the photometer settings:

<ul style="list-style-type: none"> ● <i>Reset configuration</i> 	<p>All settings except for the measurement data memory, user-defined methods and measured blank values are deleted.</p>
<ul style="list-style-type: none"> ● <i>Delivery condition</i> 	<p>All settings (including measurement data memory and user-defined methods) are deleted and the photometer is reset to the delivery condition.</p>

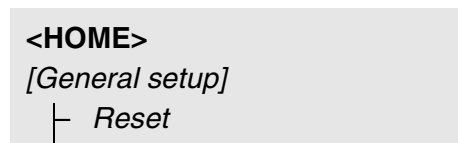

The menu where to select the reset type (*Delivery condition / Reset configuration*) is displayed.

- 1 Select and confirm the reset type. The reset is carried out.

4.17 Photometer information ([Info])

The following photometer information is displayed:

- Photometer designation
- Version number of the meter software/method data
- Hardware version
- Series number of the meter
- Registered user
- Hardware status (for service purposes)
- Memory status

<HOME>
[Info]

Info	 04/16/07 9:52
Model designation:	photoLab® 6600 UV-VIS
Serial number:	07440001
Software/methods version:	1.30-WTW-1.60
Build:	04/03/09 11:57
Hardware version:	0-
Hardware status:	FF 00000000
Lamp counter	12
System test	✓
Filter test	✓
Wavelength calibration	✓
Free internal memory space	✓
Registered user	✓

The meter information and result of the self-test are displayed and can be printed.

4.18 Lamp counter

The photometer counts the operating hours of the lamp. The information on the operating hours of the lamp is given in the *Info* menu.

The number quoted there corresponds to the number of flashes.

4.19 Software and methods update

The software and method update is used to continuously update your photometer.



Note

Only users of the user group, *Administrator* are allowed to carry out a software and method update.

The update comprises

- the newest firmware (meter software)
- new or changed method data



Note

User-defined data (such as settings, user-defined methods or measured data) are not changed by a software and methods update.

The current software version is available on the Internet under <http://www.WTW.com>.

The software can be transmitted to the photometer as follows:

- by means of a USB memory device as a temporary storage (section 4.19.1).
- by means of a USB connection between a PC and the photometer (section 4.19.2).

4.19.1 Update by means of a USB memory device

Store the new software required for the update on the USB memory device and connect it to the photometer.

Execution

- 1 Connect the USB memory device to the PC.
- 2 Unpack the contents of the downloaded exe or zip file with the complete folder structure in the main directory (top level) of the USB memory device.

**Note**

Make sure the folder structure of the files is retained while the files are unpacked. If you use a program such as WinZip to unpack the files, the option, "Nutze Ordnernamen" or "Use Folder Names" must be set. Details are given in the documentation of the unpack program.

The "Update" folder must be on the top level of the USB memory device. The Update folder contains several subfolders.

The following steps are carried out at the photometer.

- 3 Connect the USB memory device to the photometer.
- 4 Switch on the photometer if necessary.

```
<HOME>
[General setup]
├─ Software/methods update
```

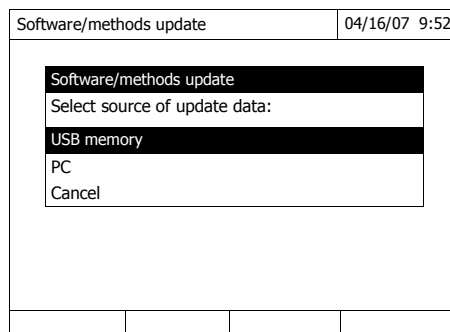

- 5 Using <▲><▼>, select *USB memory* as the source and press <START·ENTER>.

The update process takes approx. five minutes.

The photometer switches itself off and then on again.

**Note**

If the update cannot be carried out, an error message is displayed. Check whether the "Update" folder with its subfolders is stored on the USB memory device (top level).

4.19.2 Update by means of a PC

Requirements

The following is required for the update:

- A free USB connection on the PC
- A USB cable (type A - type B)
- The SpectralTransfer program.
It is on the CD-ROM provided with the photometer.
- The ActiveSync® program.
It is available free of charge in the download area of Microsoft on the Internet.
- The current photometer update file.
It is available on the Internet under <http://www.WTW.com>.
The update file comprises:
 - the newest firmware (meter software)
 - new or changed method data.
- at least 3 MB free storage on the photometer.



Note

You can view the currently available free storage on the photometer in the Info menu.

If less free storage is available than required for the update, the update is not possible with a PC at the moment.

You can either erase measurement data from the photometer until enough free storage is available, or you can carry out the update by means of a USB memory device. The free storage is required during the update only.

After a successful update, this storage is released again.

Execution

The execution of the software and method update with a PC is described in detail in the operating manual of the SpectralTransfer program. The operating manual (pdf file) is on the CD-ROM provided with the photometer.

The update process takes approx. five minutes.

The photometer switches itself off and then on again.

4.19.3 Software update "Chinese character set"

If you want to display on your photometer the languages, "Simplified Chinese/中文" or "Traditional Chinese/繁體中文", a Chinese character set is required to display the Chinese characters. This character set is not preinstalled.

You can install on your photometer this character set with the software update, "Chinese character set". It permanently requires 2 MB free storage on your photometer.



Note

The installation of this character set is not reversible. Therefore, if you do not intend to set the photometer language to Chinese, we recommend not to install the update, "Chinese character set".

Before the update

Before carrying out the software update, "Chinese character set", make sure the current software version is installed on the photometer. The newest software version is available from your instrument manufacturer as an update on the Internet. Download this update and install it before starting the software update, "Chinese character set".

Requirements

The update by means of a USB memory device requires:

- at least 2 MB free storage on the photometer.

The update by means of a PC requires:

- at least 4 MB free storage on the photometer.



Note

You can view the currently available free storage on the photometer in the Info menu. If less free storage is available than required for the update, the update is not possible. You can erase measurement data from the photometer until enough free storage is available.

Update

Carry out this update in the same way as a software and methods update.

The update process takes approx. two minutes. Subsequently, the photometer switches itself off.

5 Maintenance and cleaning

5.1 Exchanging the buffer batteries



Caution

There is a risk of explosion if unsuitable batteries are used. Only use leakproof alkaline manganese batteries.



Note

If you leave the photometer switched on during the exchange or insert the new batteries within a minute after taking out the old ones, the date and time are retained in the photometer.

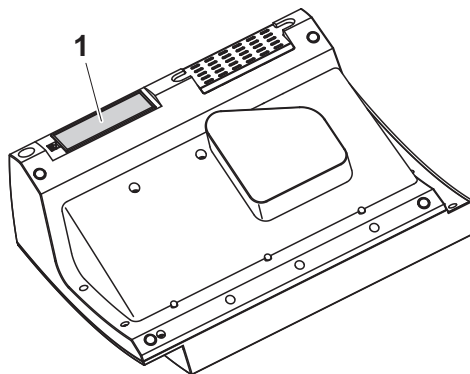

- 1 Turn the photometer upside down and place it on a soft surface.
- 2 Open the lid of the battery compartment (1).
- 3 Remove the old batteries from the battery compartment.
- 4 Insert the four new batteries in the battery compartment. Make sure that the poles of the batteries are in the correct position. The \pm signs on the batteries must correspond to the \pm signs in the battery compartment.
- 5 Close the lid of the battery compartment.

Battery service life

The power consumption of the clock is very low. The lifetime of high quality batteries is at least 5 years.

Disposal of batteries

Dispose of the batteries at a suitable facility according to local legal requirements. It is illegal to dispose of the batteries with household refuse.

5.2 Cleaning



Caution

The housing components are made out of synthetic materials (ABS, PMMA and PC). Thus, avoid contact with acetone, ethyl alcohol and similar detergents that contain solvents. Any splashes must be wiped off immediately.

Clean your photometer as follows:

- If the housing surface is dirty, wipe it with a soft cloth and mild soapy water.
- Remove any chemicals splashes as soon as possible.
- For disinfection, you can use isopropanol for cleaning for a short time.

6 What to do if ...

6.1 Actions in the case of a broken cell



Warning

Cells can contain dangerous substances. If the contents are released, follow the safety instructions of the package insert. If necessary, take corresponding protective measures (protective goggles, protective gloves etc.).



Caution

Do not turn the photometer upside down to remove the liquid! When doing so, the liquid could come into contact with electronic components and damage the photometer.

The photometer has a drain device through which the contents of a broken cell can drain off without causing any damage.

Proceeding after a cell has broken

- 1 Switch off the photometer and disconnect it from the power supply.
- 2 Let the liquid drain off into a suitable container and dispose of it properly according to the instructions of the reagent package
- 3 Carefully clean the cell shaft using a moist, lint-free cloth
- 4 Let the cell shaft dry.



Note

After recommissioning, carry out the photometer monitoring for all measurements (see section 4.14.2).

6.2 Error causes and remedies

Instrument does not react to keystroke

Cause	Remedy
<ul style="list-style-type: none"> – Software error – Operating condition undefined or EMC load unallowed 	<ul style="list-style-type: none"> – Processor reset: Press the <ON/OFF> and <ESC> key simultaneously.

Acoustic signal on keystroke

Cause	Remedy
<ul style="list-style-type: none"> – The key does not have any function in the current operating state 	<ul style="list-style-type: none"> – Press a different key

Measuring range undercut or exceeded

Cause	Remedy
<ul style="list-style-type: none"> – Method not suitable 	<ul style="list-style-type: none"> – Select method with suitable measuring range – Dilute the sample



Note

In *Concentration* mode you can display the current absorbance value as an additional information (*[Setup]/Display absorbance*, see also section 4.5.6).

Self-test does not start. The instrument displays *Please remove cell*

Cause	Remedy
<ul style="list-style-type: none"> – Cell is inserted 	<ul style="list-style-type: none"> – Remove the cell – Press the <START·ENTER> key.
<ul style="list-style-type: none"> – Foreign object is in the cell shaft 	<ul style="list-style-type: none"> – Remove foreign object – Press the <START·ENTER> key.
<ul style="list-style-type: none"> – The instrument has to carry out an automatic balancing process for the rectangular cell recognition 	<ul style="list-style-type: none"> – Press the <START·ENTER> key.
<ul style="list-style-type: none"> – The rectangular cell shaft is contaminated 	<ul style="list-style-type: none"> – Clean the cell shaft – Restart the instrument – If necessary, confirm the <i>Please remove cell</i> message with <START·ENTER>.
<ul style="list-style-type: none"> – Instrument defective 	<ul style="list-style-type: none"> – Return instrument to service department

Obviously incorrect measured values

Cause	Remedy
– Cell contaminated	– Clean the cell
– Dilution set incorrectly	– Set the dilution
– Selected method not suitable	– Select different method
– Zero measurement incorrect	– Perform zero measurement
– Blank value incorrect	– Remeasure the blank value
– Cells that are not recognized (e.g. some plastic cells) disturb the AutoCheck measurement and, as a consequence, falsify measured values until the next AutoCheck is carried out	– Use suitable cells (see section 7.1 and section 8.1)

Fluctuating measured values

Cause	Remedy
– Cell shaft cover open	– Close the cell shaft cover

Self test failed.

Cause	Remedy
– <i>System test</i> : Instrument defective	– Return instrument to service department
– <i>Filter test</i> : Instrument defective	– Return instrument to service department
– <i>Lamp test</i> : Lamp defective	– Return instrument to service department
– <i>Wavelength calibration</i> : – Foreign particle in the cell shaft – Instrument defective	– Clean the cell shaft – Return instrument to service department

Connected printer does not print

Cause	Remedy
– Printer not suitable	– Connect a printer that can interpret the printer control language PCL-3

7 Technical data

7.1 Measurement characteristics

Measuring principle Single-beam spectrophotometer

Light source	Lamp type	Xenon flashlamp
	Durability	5 x 10 ⁸ flashes, corresponding to at least 13000 h in permanent operation
Monochromator	Type	Grating monochromator with step motor
	Wavelength range	190 - 1100 nm
	Max. scan speed	approx. 3300 nm/min
	Wavelengths calibration	Automatic
	Accuracy	± 1 nm
	Reproducibility	± 0.5 nm (checkable, e.g. with holmium oxide filter)
	Resolution	1 nm
	Spectral band width	4 nm
Photometric measurement	Light sensor	Photo diode
	Measuring range	A = -3.300 to A = +3.300
	Linearity	< 1 % for A ≤ 2.000 in the range 340 to 900 nm
	Accuracy *	– 0.003 A for A < 0.600 – 0.5 % of the reading for 0.600 ≤ A ≤ 2.000
	Reproducibility *	± 0.002 at A = 1.000
	Resolution	ΔA = 0.001
	Scattered light	< 0.1 % transmission at 340 and 408 nm

* in the range 200nm ... 1000nm

Cells to be used	Round cells	<ul style="list-style-type: none"> – Outer diameter: 16 mm – Inner diameter: 13.6 mm – Flat cell bottom
	Rectangular cells *	<ul style="list-style-type: none"> – Path length: 10 mm, 20 mm and 50 mm – Maximum width: 12.6 mm
	Minimum filling level	20 mm
	Minimum filling volume	Round cell 16 mm: 4 ml Rectangular cell, 10 mm: 2 ml Rectangular cell, 20 mm: 4 ml Rectangular cell, 50 mm: 10 ml
	Cell recognition	Automatic for most types

- *Suitable are rectangular glass cells with opaque lateral surfaces (see section 8.1). Plastic cells with clear or serrated lateral surfaces are not reliably recognized by the automatic cell recognition. Cells that are not recognized disturb the AutoCheck measurement and, as a consequence, falsify measured values until the next AutoCheck is carried out.*

Warm-up time At least 15 min for single measurements
 2 h for kinetic measurements with the highest possible precision

FCC Class A Equipment Statement

Note: This equipment has been tested and found to comply with the limits for a Class A digital device, pursuant to Part 15 of the FCC Rules. These limits are designed to provide reasonable protection against harmful interference when the equipment is operated in a commercial environment. This equipment generates, uses, and can radiate radio frequency energy and, if not installed and used in accordance with the instruction manual, may cause harmful interference to radio communications. Operation of this equipment in a residential area is likely to cause harmful interference in which case the user will be required to correct the interference at his own expense.

Measuring modes

- Concentration
 - Measurement with permanently programmed methods, adapted to the WTW test set program
 - Automatic method selection if test sets with barcodes are used
 - Program support for the creation of additional user-defined methods (max. 100)
 - Citation forms and units method dependent
 - Display of the absorbance value can be added
 - Method data update possible via Internet
- Absorbance / % Transmission
 - Measurement against own reference absorbance value possible
- Multi wavelengths
 - Freely definable calculations from up to four individual absorbance values at different wavelengths
 - Calculations can be stored as methods (max. 50)
- Spectrum
 - Absorbance or % transmission mode
 - Limits freely selectable within the wavelength range
 - Increment: 1 nm
 - Recording duration for the complete wavelength range: < 7 min
 - Settings can be stored as profiles (max. 20)
 - Evaluation functions: Cursor scanning, zoom, min./max. recognition, peak area determination, derivation, smoothing, multiplication by constants, addition of constants, addition and subtraction of spectra, formation of the quotient of two spectra
- Kinetics
 - Absorbance or % transmission mode
 - Minimal adjustable scan interval: 1 s (if the absorbance of the test sample is high, the scan interval is extended due to the longer duration of the individual measurements)
 - Settings can be stored as profiles (max. 20)
 - Evaluation functions: Cursor scanning, zoom, min./max. determination, slope calculation (for an interval or total), enzymatic activity

7.2 Measured value documentation and quality assurance

Memory for measured values	Memory capacity	<ul style="list-style-type: none"> – 1000 single measured values from the measuring modes, concentration, absorbance / % transmission and multi wavelengths – 4 MByte internal memory, sufficient for approx. 100 spectra and 400 kinetic curves (sample values based on the following assumptions: All spectra over a wavelength range of 600 nm and all kinetic curves with 150 single values each)
	Output options	USB memory device, printer, PC
	File formats	ASCII, *.csv
Monitoring functions	AQA1	Check of the photometer
	AQA2	Check of the total system
	AQA3	Check of the sample matrix
User management	Can be switched off	yes
	User accounts	3 hierarchical levels (administrator, user, guest)
	Password protection	for administrators and users

7.3 General meter data

Dimensions	404 x 197 x 314 mm (width x height x depth)	
Weight	approx. 4.5 kg (without plug-in power supply)	
Housing type of protection	IP 30	
Electrical protective class	III	
Test mark	CE, cETLus	
Allowed environmental conditions	Temperature	Operation: +10 °C to + 35 °C (41 °F to 95 °F) Storage: -25 °C to + 65 °C (-13 °F to 268 °F)
	Humidity	Yearly mean: ≤ 75 % 30 days/year: 95 % other days: 85%
	Climatic class	2
	Power supply	Power pack
Guidelines and norms used	EMC	EC directive 2004/108/EC EN 61326-1 EN 61000-3-2 EN 61000-3-3 FCC Class A
	Instrument safety	EC directive 2006/95/EC EN 61010-1
	Climatic class	VDI/VDE 3540
	IP protection	EN 60529

Communication interfaces	RS232	1 x 9-pin D-sub
	USB	<ul style="list-style-type: none"> – 1 x USB-A (for printer, USB memory devices, keyboard or bar code reader) – 1 x USB-B (for PC)

- Other features**
- Drain for spilled cell contents
 - Photometer software update and method data update possible via Internet

- Available languages**
- Deutsch
 - English
 - Français
 - Español
 - Italiano
 - Bulgarian/Български
 - Česko
 - Simplified Chinese/ 中文
 - Traditional Chinese/ 繁體中文
 - Greek/Ελληνικά
 - Indonesian/Indonesia
 - Japanese/ 日本語
 - Magyar
 - Malay/Melayu
 - Norsk
 - Polski
 - Português
 - Russian/Русский
 - Slovenščina

8 Accessories and options

8.1 Accessories

Cells for the WTW test set program

Description	Model	Order no.
25 empty round cells (16 mm)	RK 14/25	250 621
Rectangular cell, 10 mm	REK 10	250 605
Rectangular cell, 20 mm	REK 20	250 600
Rectangular cell, 50 mm	REK 50	250 614
Rectangular cell, quartz, 10 mm	REK 10 Quarz	250 606
Rectangular cell, quartz, 20 mm	REK 20 Quarz	250 601
Rectangular cell, quartz, 50 mm	REK 50 Quarz	250 615

Case and cable for mobile use

Description	Order no.
Case for photoLab® 6600 UV-VIS (identical to case for spectroFlex)	250 212
Car Adapter photoLab® 6xxx (identical to Car Adapter spectroFlex)	902 760

8.2 Test equipment

Test equipment	Description	Model	Order no.
	Test equipment for AQA1	PhotoCheck 14693	250 490
	Test equipment for pipette volume	PipeCheck 14692	250 498



Note

Standard solutions for the WTW test set program are listed in the WTW catalog or on the Internet.

8.3 Optional equipment

The following optional extensions are available in specialist shops:

- USB barcode reader (hand scanner)
- USB PC keyboard

8.4 Connection cable:

PC You can connect a PC to the photoLab® 6600 UV-VIS in one of the following ways:

Description	Order no.
– Cable with USB-B and USB-A plug	Specialist shops
– Zero modem cable 9-pin (D-sub socket) - 9-pin (D-sub socket)	820 070

USB printer You can connect a USB printer to the photoLab® 6600 UV-VIS:

Description	Order no.
– Cable with USB-B and USB-A plug	Specialist shops

Thermoprinter You can connect the P3001 thermoprinter to the photoLab® 6600 UV-VIS in the following ways:

Description	Order no.
– Cable with GenderChanger	250 745
or:	
– Cable, 9-pin (socket) - 9-pin (plug)	Specialist shops

Needle printer You can connect an LQ300 needle printer to the photoLab® 6600 UV-VIS in one of the following ways:

Description	Order no.
– Cable with GenderChanger	250 746
or:	
– Zero modem cable, 9-pin (D-Sub socket) - 25-pin (plug)	Specialist shops

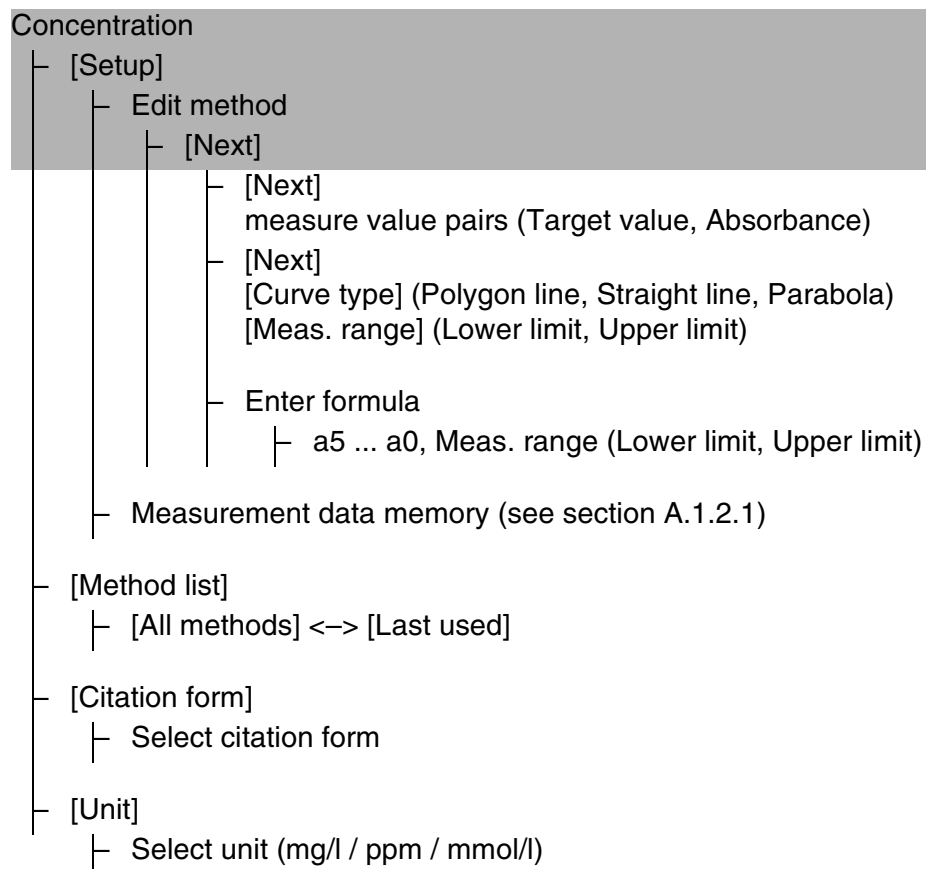

A.1.1.2 Absorbance / % Transmission

Absorbance / % Transmission

- ├ [Setup]
 - ├ AQA (see section A.1.2.2)
 - ├ Measurement data memory (see section A.1.2.1)
- ├ [Wavelength]
 - ├ Set new wavelength (nm)
- ├ [Transmission] <-> [Absorbance]
- ├ [Reference]
 - ├ Reference absorbance

A.1.1.3 Multi wavelengths

Multi wavelengths

- ├ [Setup]
 - ├ New method
 - ├ Number, Name, Version, Citation form, Unit, Resolution, Cell
 - ├ [Method list]
 - ├ [All methods] <-> [Last used]
 - ├ [Delete]
 - ├ [Next]
 - ├ Wavelength 1 ... 10, a0 ... a10, b0 ... b10, Function
 - ├ Edit method(see New method)
 - ├ Measurement data memory (see section A.1.2.1)
 - ├ AQA (see section A.1.2.2)
- ├ [Method list]
 - ├ [All methods] <-> [Last used]
- ├ [Transmission] <-> [Absorbance]

A.1.1.4 Spectrum

Spectrum

- [Setup]
 - Wavelength start
 - Wavelength stop
 - Mode
 - Absorbance
 - Transmission
 - Smoothing
 - Yes
 - No
 - Scaling
 - Auto
 - Manual
 - Y-axis min
 - Y-axis max
- [Edit]
 - Extreme values (zoomed area)
 - Mark points
 - Delete all marks
 - Original values
 - Integral
 - Derivative
 - Compare spectrum
 - Add spectrum
 - Subtract spectrum
 - Divide spectrum (ratio)
 - Add fixed value
 - Multiply fixed value
- [Zoom]
 - [Original]
 - [xy_max]
- [Open]

A.1.1.5 Kinetics

Kinetics

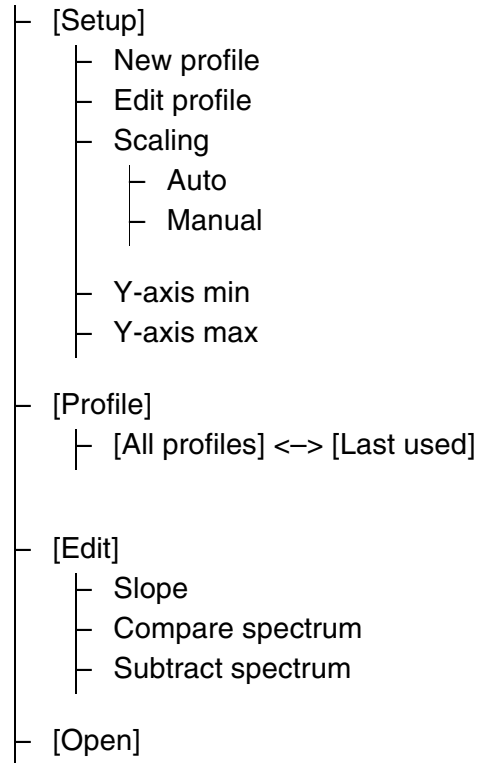

A.1.2 General settings and functions

- [General setup] (see section A.1.2.1)
- [Logout]
- [AQA] (see section A.1.2.2)
- [Info]

A.1.2.1 General setup

[General setup]

- Language
- Date/Time
 - Date
 - Time
- Display settings
 - Contrast [%]
- User management
 - [Setup]
 - Deactivate user management
 - Change password
 - [Add]
 - [Delete]
 - [Change]
- Measured value memory
 - [Setup]
 - AutoStore (✓)
 - Filter
 - Mode
 - Absorbance / Transmission
 - Concentration
 - Multi wavelength
 - User
 - ID
 - Date
 - from ... to ...
 - [Reset entry]
 - [Reset all]
 - Selected values: invert selection (✓)
 - Delete memory (selected values only)
 - Delete memory (all values)
 - [Single value] <--> [List]
 - [Delete]

[General setup]

- Software/methods update
 - USB memory
 - PC
 - Cancel
- Reset
 - Reset configuration
 - Delivery condition
- Data transfer/Printer
 - Decimal separator for csv-Files
 - Point (12.34)
 - Comma (12,34)
 - Data format (print)
 - Short
 - Extended
 - Baudrate for printer (1200 ... 19200)
- Save all data on USB memory

A.1.2.2 AQA

[AQA]

- AQA1 setup
 - Mode
 - AQA1 inactive
 - Weeks
 - Interval
 - Lock instrument (No/Yes)
 - Configuration of tests ...
 - PhotoCheck
 - CertiPUR UV-VIS 1 ...
- AQA2 setup
 - Mode
 - AQA2 inactive
 - Weeks
 - Measurements
 - Lock methods (No/Yes)
 - Method...
 - [All methods] <-> [Last used]
 - Method
 - AQA2
 - Interval
 - Target value
 - Tolerance
 - Standard ID
- AQA3/MatrixCheck setup
 - Maximum difference
- AQA1 check
- AQA2 check
 - [All methods] <-> [Last used]
- AQA3/MatrixCheck
- AQA1 info
- AQA2 info

A.2 Glossary

Absorbance	Logarithmic dimension for the absorption of the sample; negative decadal logarithm of the transmission.
Analysis instructions	The exact proceeding to carry out the detection procedure is described in the analysis instructions.
AQA	Analytical Quality Assurance.
AQA labeling	In the documentation, measured values are given an AQA labeling (AQA1 or AQA2), depending on whether or not the measurement was carried out with AQA and with which AQA level.
AQA1	1st step of the analytical quality assurance: Monitoring of the instrument.
AQA2	2nd step of the analytical quality assurance: Monitoring of the total system.
AQA3	3rd step of the analytical quality assurance: Check of whether the photometric determination is disturbed by other sample ingredients (sample matrix). The MatrixCheck can be carried out by spiking or diluting:
AutoSelector	Plastic cylinder with bar code. It is inserted in the round cell shaft and transmits the code for a reagent test set to the photometer.
Bar code	Optical code (black and white bars) of the method that can be read by light barriers in the photometer.
Baseline	Reference value for the spectrum of reference absorbances or reference transmissions.
Cell	Vessel to take a liquid sample for measurement in a photometer. The cell material (mostly glass) must have certain optical features to be suitable for photometry.
Citation forms	Different forms of representing a measured concentration value that can be derived from each other. The method for the determination of phosphate, e.g. supplies a measured value for phosphorous P. This measured value can alternatively be given in the citation forms PO ₄ , PO ₄ -P or P ₂ O ₅ .
CombiCheck	Multiparameter standards used to check the total system for a method.
Concentration	Mass or amount of a dissolved substance per volume, e.g. in g/l or mol/l.

Correlation coefficient	Specifies the extent of the linear relationship of value pairs when determining the zero point and slope for a user-defined method.
Detection procedure	The detection procedure designates the general principle of how a sample is brought into a form suitable for measurement. Different methods can be based on the same detection procedure.
Kinetics	Measurement over a period of time.
MatrixCheck	see AQA3.
Measured value	The measured value is the special value of a measured parameter to be determined. It is given as a combination of the numerical value and unit (e.g. 3 m; 0.5 s; 5.2 A; 373.15 K).
Method	A method comprises a chemical detection procedure and special method data (calibration line) that is required to evaluate the measurement results. How to carry out the method up to measuring with the photometer is described in the analysis instructions. The photoLab® 6600 UV-VIS contains a database with methods. Furthermore, user-defined methods can be entered in the database as well.
PhotoCheck standard	Stable color solution with defined absorbance values for the check of the photometer.
Reagent blank value	The evaluation of the photometric measurement always refers to the comparison value of a test sample without the substance to be determined (reagent blank value). Thus the influence of the basic absorbance of the reagents on photometric measurement is compensated for.
Recovery	The recovery rate is the found measured value divided by the default value (percentage). Example: Default value 20 mg/l; Found 19.7 mg/l => recovery 0.985 or recovery rate 98.5%.
Reference absorbance	With the reference absorbance, the basic absorbance stored in the photometer can be replaced by a measurement of your own.
Reset	Restoring the original condition of all settings of a measuring system.
Sample blank value	Absorbance value of the original test sample, handled according to prescription but without color reagent.
Spectrum	Distribution of the intensity, transmission or absorbance depending on the wavelength.
Standard	Sample with a defined concentration of the analyte to be determined.

Test sample	Designation of the test sample ready to be measured. Normally, a test sample is made by processing the original sample. The test sample and original sample are identical if the test sample was not processed.
Test set (test)	A test set contains all reagents that are required for the photometric determination of the sample according to the analysis instructions.
Transmission	Part of the light that goes through the sample.
Turbidity	Light attenuation caused by diffuse scattering at undissolved substances.
Zero adjustment	Adjusting a photometer with a water-filled cell.

A.3 List of trademarks

Trademark	Owner
ActiveSync®	Microsoft Corporation
CertiPUR®	Merck KGaA
Microsoft®	Microsoft Corporation
Spectroquant®	Merck KGaA
Windows®	Microsoft Corporation

3.1 Index

A	
Absorbance / % Transmission, measuring	69
Accessories	163
Analysis timer	100
Analytical quality assurance (AQA)	120
AQA	120
Authorized use	12
AutoCheck	27
B	
Barcode	41
Barcode reader	23
Blank value	
Reagent blank value	54
Sample blank value	52
C	
Cell breakage	153
Cleaning	152
Commissioning	15
Concentration measurement	41
Connections	7
Copying files	112
D	
Dataset	105
Date/time	35
Disinfection	152
G	
Glossary	175
I	
Initial commissioning	15
Initialization	144
Instrument settings	34
IQ LabLink	68
K	
Keypad	8
Kinetics	88
M	
Measure diluted sample	50
Measured value memory	105, 106, 107
Measurement dataset	105

Menus	167
Meter information	145
Method	77
Methods update	146
Multi-wavelengths methods	73
O	
Operating elements	7
Operating principles	28
Operational safety	12
Overview	7
P	
Print	116
Printer	116
Profile (kinetic)	91
Profile (Spectrum)	80
R	
Reagent blank value	
Measuring the	56
Reference absorbance	71
Reset	144
RS232	
Connection	20
Interface parameters	22
S	
Safe operation	12
Safety instructions	11
Sample blank value	52
Saving	102
Scope of delivery	15
Self-test	26
Socket field	7
Software update	146
Software version number	145
Switching on	25
System info	145
System management	34
System menu	
General information	48
T	
Technical data	157
Timer	99
Turbidity correction	58

U	
Update	146
USB memory device	22
User-defined methods	
Concentration	58
Multi wavelengths	74
W	
Warm-up time	26
Z	
Zero adjustment	37



Wissenschaftlich-Technische Werkstätten GmbH

Dr.-Karl-Slevogt-Straße 1
D-82362 Weilheim

Germany

Tel: +49 (0) 881 183-0
 +49 (0) 881 183-100
Fax: +49 (0) 881 183-420
E-Mail: Info@WTW.com
Internet: <http://www.WTW.com>